



Count on it.

Operator's Manual

**Multi Pro[®] 5800-G Turf Sprayer
with ExcelaRate[™] Spray System**

Model No. 41394—Serial No. 316000001 and Up

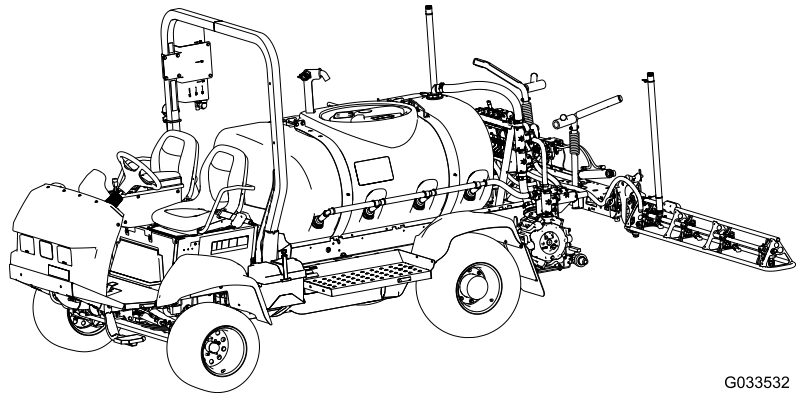

G033532



The Multi-Pro® turf sprayer is a dedicated turf spray application vehicle and is intended to be used by professional, hired operators in commercial applications. It is primarily designed for spraying on well-maintained lawns in parks, golf courses, sports fields, and on commercial grounds.

It is a violation of California Public Resource Code Section 4442 or 4443 to use or operate the engine on any forest-covered, brush-covered, or grass-covered land unless the engine is equipped with a spark arrester, as defined in Section 4442, maintained in effective working order or the engine is constructed, equipped, and maintained for the prevention of fire.

This spark ignition system complies with Canadian ICES-002

The enclosed *Engine Owner's Manual* is supplied for information regarding the US Environmental Protection Agency (EPA) and the California Emission Control Regulation of emission systems, maintenance, and warranty. Replacements may be ordered through the engine manufacturer.

⚠ WARNING

**CALIFORNIA
Proposition 65 Warning**

The engine exhaust from this product contains chemicals known to the State of California to cause cancer, birth defects, or other reproductive harm.

Use of this product may cause exposure to chemicals known to the State of California to cause cancer, birth defects, or other reproductive harm.

Introduction

Read this manual carefully to learn how to operate and maintain your product properly. The information in this manual can help you and others avoid injury and product damage. Although Toro designs and produces safe products, you are responsible for operating the product properly and safely. You may contact Toro directly at www.Toro.com for product and accessory information, help finding a dealer, or to register your product.

Whenever you need service, genuine Toro parts, or additional information, contact an Authorized Service Dealer or Toro Customer Service and have the model

and serial numbers of your product ready. [Figure 1](#) illustrates the location of the model and serial numbers on the product.

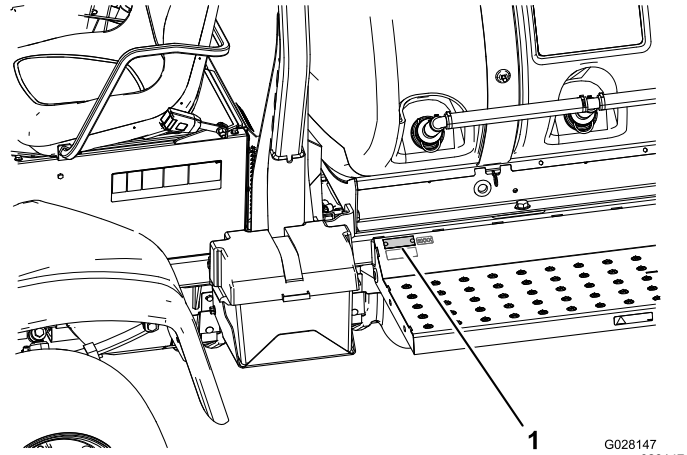

Figure 1

1. Location of the model and serial numbers

<p>Model No. _____</p> <p>Serial No. _____</p>
--

This manual identifies potential hazards and has safety messages identified by the safety-alert symbol ([Figure 2](#)), which signals a hazard that may cause serious injury or death if you do not follow the recommended precautions.



Figure 2

1. Safety-alert symbol

This manual uses 2 words to highlight information. **Important** calls attention to special mechanical information and **Note** emphasizes general information worthy of special attention.

Contents

Safety	4	Checking the Fuel Line and Connections.....	58
Safe Operating Practices.....	4	Servicing the Fuel Filter	58
Chemical Safety	5	Draining the Fuel Tank.....	61
Operating.....	6	Bleeding the Fuel System	61
Maintenance.....	7	Electrical System Maintenance	61
Safety and Instructional Decals	9	Replacing the Fuses	61
Setup	15	Servicing the Battery.....	62
1 Checking the Boom-Hinge Springs	15	Drive System Maintenance	63
2 Removing the Shipping Bumper.....	16	Inspecting the Wheels/Tires.....	63
Product Overview	17	Changing the Planetary-Gearbox Fluid.....	63
Controls	18	Adjusting the Front Wheel Toe-in	64
InfoCenter Main Menu Screen.....	24	Cooling System Maintenance	65
Specifications	35	Servicing the Cooling System	65
Operation	35	Brake Maintenance	67
Think Safety First.....	35	Adjusting the Brakes.....	67
Performing Pre-Starting Checks	35	Belt Maintenance	67
Preparing to Drive the Machine.....	36	Servicing the Alternator Belt	67
Preparing to Use the Sprayer.....	37	Hydraulic System Maintenance	68
Operating the Machine	38	Checking the Hydraulic Fluid	68
Breaking in a New Sprayer	39	Servicing the Hydraulic Fluid	69
Operating the Sprayer	39	Sprayer System Maintenance	71
Filling the Fresh-Water Tank	40	Inspecting the Hoses	71
Filling the Spray Tank.....	40	Changing the Pressure Filter	72
Operating the Booms.....	41	Spray System Schematic.....	73
Applying Spray	41	Pump Maintenance	74
Taking Proper Turf Care Precautions while		Inspecting the Pump	74
Operating in Stationary Modes.....	42	Adjusting the Actuators.....	74
Spraying Tips.....	42	Inspecting the Pivot Bushings.....	75
Unclogging a Nozzle.....	42	Cleaning	75
Selecting a Nozzle.....	42	Cleaning the Radiator-Cooling Fins	75
Cleaning the Sprayer.....	42	Cleaning the Agitation and Section	
Setting the Boom-Section-Bypass		Valves	75
Valves	44	Storage	81
Positioning the Agitation-Bypass-Valve		Troubleshooting	83
Knob	44		
Calibrating the Agitation-Bypass Valve	45		
Locating the Pump.....	45		
Transporting the Sprayer	46		
Towing the Sprayer	46		
Maintenance	48		
Recommended Maintenance Schedule(s)	48		
Daily Maintenance Checklist.....	49		
Notation for Areas of Concern.....	50		
Pre-Maintenance Procedures	50		
Jacking the Sprayer Up.....	50		
Accessing the Engine	51		
Lubrication	52		
Greasing the Sprayer.....	52		
Greasing the Boom Hinges.....	52		
Greasing the Actuator-Rod Bearings	53		
Engine Maintenance	54		
Checking the Air Cleaner.....	54		
Servicing the Engine Oil.....	56		
Checking the PCV Valve.....	58		
Fuel System Maintenance	58		

Safety

Improper use or maintenance by the operator or owner can result in injury. To reduce the potential for injury, comply with these safety instructions and always pay attention to the safety alert symbol, which means Caution, Warning, or Danger—personal safety instruction. Failure to comply with the instruction may result in personal injury or death.

The machine meets the requirements of SAE J2258.

Safe Operating Practices

Important: Important: The machine is designed primarily as an off-road vehicle and is not intended for extensive use on public roads. When using the machine on public roads, follow all traffic regulations and use any additional accessories that may be required by law, such as lights, turn signals, slow moving vehicle (SMV) sign, and others as required.

The Multi Pro® 5800 Turf Sprayer was designed and tested to offer safe service when operated and maintained properly. Although hazard control and accident prevention partially are dependent upon the design and configuration of the machine, these factors are also dependent upon the awareness, concern, and proper training of the personnel involved in the operation, maintenance and storage of the machine. Improper use or maintenance of the machine can result in injury or death.

Not all of the attachments that adapt to the Multi Pro®5800 Turf Sprayer are covered in this manual. See the specific operator's manual provided with each attachment for additional safety instructions.

To reduce the potential for injury or death, comply with the following safety instructions:

Supervisor's Responsibilities

- Make sure that operators are thoroughly trained and familiar with the *Operator's Manual*, engine owner's manual, and all labels on the sprayer.
- Establish your own special procedures and work rules for unusual operating conditions (e.g., slopes too steep for sprayer operation).

Training

- Read the *Operator's Manual* and other training material before operating the machine.
- Note:** If the operator(s) or mechanic(s) cannot read the manual language, it is the owner's responsibility to explain this material to them.

- Become familiar with the safe operation of the equipment, operator controls, and safety signs.
 - All operators and mechanics should be trained. The owner is responsible for training the users.
 - Never allow untrained people to operate or service the equipment.
- Note:** Local regulations may restrict the age of the operator.
- The owner/operator can prevent and is responsible for accidents or injuries occurring to themselves, other people, or damage to property.

Before Operating

- Operate the machine only after reading and understanding the contents of this manual.
- **Never** allow children to operate the sprayer.
- **Never** allow other adults to operate the sprayer without first reading and understanding the *Operator's Manual*. Only trained and authorized persons should operate this sprayer. Make sure that all operators are physically and mentally capable of operating the sprayer.
- This sprayer is designed to carry the operator and **1 passenger** in the seat provided by the manufacturer. **Never** carry any additional passengers on the sprayer.
- **Never** operate the sprayer when under the ill, tired, or under the influence of drugs or alcohol.
- Become familiar with the controls and know how to stop the engine quickly.
- Keep all shields, safety devices, and decals in place. If a shield, safety device, or decal is malfunctioning, illegible, or damaged, repair or replace it before operating the machine.
- Wear appropriate clothing; including safety glasses, long pants, substantial slip-resistant safety shoes or substantial footwear, rubber boots, gloves, and hearing protection. Do not wear jewelry. Tie back long hair.

⚠ CAUTION

This machine produces sound levels in excess of 85 dBA at the operator's ear and can cause hearing loss through extended periods of exposure.

Wear hearing protection when operating this machine.

- Operate only in daylight or good artificial light.

Chemical Safety

⚠ WARNING

Chemical substances used in the spreader-sprayer system may be hazardous and toxic to you, bystanders, animals, plants, soils or other property.

- **Carefully read and follow the chemical warning labels and Material Safety Data Sheets (MSDS) for all chemicals used and protect yourself according to the chemical manufacturer's recommendations. Ensure that as little skin as possible is exposed while using chemicals. Use appropriate Personal Protective Equipment (PPE) to guard against personal contact with chemicals, such as:**
 - safety glasses, goggles, and/or face shield
 - respirator or filter mask
 - chemical resistant gloves
 - rubber boots or other substantial footwear
 - hearing protection
 - clean change of clothes, soap, and disposable towels, to be kept on-hand, in the event of a chemical spill.
- **Keep in mind that there may be more than one chemical used, and information on each chemical should be assessed.**
- **Refuse to operate or work on the sprayer if this information is not available!**
- **Before working on a sprayer system, make sure that the system has been triple rinsed and neutralized according to the recommendations of the chemical manufacturer(s) and all of the valves have been cycled 3 times.**
- **Verify there is an adequate supply of clean water and soap nearby, and immediately wash off any chemicals that contact you.**
- Obtain proper training before using or handling chemicals.
- Use the correct chemical for the job.
- Follow the chemical manufacturer's instructions for the safe application of the chemical. Do not exceed recommended system application pressure.
- Do not fill, calibrate, or clean the unit when people, especially children, or pets are in the area.

- Never spray while people, especially children or pets are nearby.
- Before operating the sprayer, always check the designated areas of the sprayer that are stated in the Pre-Starting Checks in the Operation section. If the machine does not function correctly or is damaged in any way, do **not** use the sprayer. Make sure that the problem is corrected before the sprayer or attachment is operated.
- Make sure that the operator and passenger area are clean and free from chemical residue and debris buildup.
- Ensure that all fluid line connectors are tight and all hoses are in good condition before applying pressure to the system.

Note: Do not use the sprayer if it is leaking or damaged.

- Handle chemicals in a well ventilated area.
- Have clean water available especially when filling the spray tank.
- Do not eat, drink, or smoke while working with chemicals.
- Do not clean spray nozzles by blowing through them or placing in mouth.
- Always wash your hands and other exposed areas as soon as possible after you finish working with chemicals.
- Keep chemicals in their original packages and stored in a safe location.
- Properly dispose of unused chemicals and chemical containers as instructed by the chemical manufacturer and your local codes.
- Chemicals and fumes are dangerous; never enter the tank or place your head over or in the opening of a tank.
- Follow all local, state, federal regulations for spreading or spraying chemicals.

- Slow down before turning. Do not attempt sharp turns or abrupt maneuvers or other unsafe driving actions that may cause a loss of sprayer control.
- Before backing up, look to the rear and ensure that no one is behind you. Back up slowly.
- Watch out for traffic when you are near or crossing roads. Always yield the right of way to pedestrians and other vehicles. This sprayer is **not** designed for use on streets or highways. Always signal your turns or stop early enough so that other people know what you plan to do. Obey all traffic rules and regulations.
- The electrical and exhaust systems of the sprayer can produce sparks capable of igniting explosive materials. Never operate the sprayer in or near an area where there is dust or fumes in the air which are explosive.
- If you are ever unsure about safe operation, **stop work** and ask your supervisor.

Operating

⚠ WARNING

Engine exhaust contains carbon monoxide, which is an odorless, deadly poison that can kill you.

Do not run engine indoors or in an enclosed area.

- The operator (and passenger) should remain seated whenever the sprayer is in motion. The operator should keep both hands on the steering wheel whenever possible. Keep your arms and legs within the sprayer body at all times.
- Failure to operate the sprayer safely may result in an accident, tip over of the sprayer, and serious injury or death. Drive carefully. To prevent tipping or loss of control:
 - Use extreme caution, reduce speed, and maintain a safe distance around sand traps, ditches, creeks, ramps, unfamiliar areas, or any areas that have abrupt changes in ground conditions or elevation.
 - Watch for holes or other hidden hazards.
 - Use extra caution when operating the sprayer on wet surfaces, in adverse weather conditions, at higher speeds, or with a full load. Stopping time and distance will increase with a full load.
 - Avoid sudden stops and starts. Do not go from reverse to forward or forward to reverse without first coming to a complete stop.

- Do not touch the engine or muffler while the engine is running or soon after it has stopped. These areas may be hot enough to cause burns.
- If the machine ever vibrates abnormally, stop immediately, wait for all motion to stop, and inspect the sprayer for damage. Repair all damage before resuming operation.
- Before getting off of the seat:
 1. Stop the movement of the machine.
 2. Remove your foot from the traction pedal and set the parking brake.
 3. Turn the key for the starter switch to the Off position.
 4. Remove the key from the starter switch.

Important: Do not park the machine on an incline.
- Lightning can cause severe injury or death. If lightning is seen or thunder is heard in the area, do not operate the machine; seek shelter.

Braking

- Slow down before you approach an obstacle. This gives you extra time to stop or turn away. Hitting an obstacle can damage the sprayer and its contents. More important, it can injure you.
- Gross Vehicle Weight (GVW) has a major impact on your ability to stop and/or turn. Heavy loads and attachments make a sprayer harder to stop or turn. The heavier the load, the longer it takes to stop.
- Turf and pavement are much more slippery when they are wet. It can take 2 to 4 times as long to stop on wet surfaces as on dry surfaces. If you drive through standing water deep enough to

get the brakes wet, they will not work well until they are dry. After driving through water, you should test the brakes to make sure that they work properly. If they do not, drive slowly while putting light pressure on the brake pedal. This will dry the brakes out.

ROPS Safety

Note: For each machine covered in this *Operator's Manual*, a cab installed by Toro is a ROPS.

- Do not remove the ROPS from the machine.
- Fasten the seat belt and ensure that you can release it quickly in an emergency. Always wear your seat belt when the roll bar is up or on a machine with a cab installed by Toro.
- Check carefully for overhead obstructions and do not contact them.
- Keep the ROPS in safe operating condition by thoroughly inspecting it periodically for damage and keeping all the mounting fasteners tight.
- Replace any damaged ROPS component. Do not repair or alter it.

Operating on Hills and Rough Terrain

Operating the sprayer on a hill may cause tipping or rolling of the sprayer, or the engine may stall and you could lose headway on the hill. This could result in personal injury.

- Do not accelerate quickly or suddenly apply the brakes when backing down a hill, especially with a load.
- Never drive across a steep hill; always drive straight up or down or go around the hill.
- If the engine stalls or you begin to lose headway while climbing a hill, gradually apply the brakes and slowly back straight down the hill.
- Turning while traveling up or down hills can be dangerous. If you have to turn while on a hill, do it slowly and cautiously. Never make sharp or fast turns.
- Heavy loads affect stability. Reduce the weight of the load and your speed when operating on hills.
- Avoid stopping on hills, especially with a load. Stopping while going down a hill will take longer than stopping on level ground. If the sprayer must be stopped, avoid sudden speed changes, which may initiate tipping or rolling of the sprayer. Do not suddenly apply the brakes when rolling backward, as this may cause the sprayer to overturn.
- Reduce speed and load when operating on rough terrain, uneven ground, and near curbs, holes, and

other sudden changes in terrain. Loads may shift, causing the sprayer to become unstable.

▲ WARNING

Sudden changes in terrain may cause abrupt steering wheel movement, possibly resulting in hand and arm injuries.

- Grip the steering wheel loosely around the perimeter. Keep your hands clear of the steering wheel spokes.

Loading

The weight of the cargo can change the sprayer center of gravity and sprayer handling. To avoid loss of control and personal injury, follow these guidelines:

- Liquid loads can shift. This shifting happens most often while turning, going up or down hills, suddenly changing speeds, or while driving over rough surfaces. Shifting loads can cause the sprayer to tip over.
- When operating with a heavy load, reduce your speed and allow for sufficient braking distance. Do not suddenly apply the brakes. Use extra caution on slopes.
- Be aware that heavy loads increase your stopping distance and reduce your ability to turn quickly without tipping over.

Maintenance

- Only permit qualified and authorized personnel to maintain, repair, adjust, or inspect the sprayer.
- Before performing any maintenance, ensure that the system has been thoroughly rinsed and cleaned.
- Before servicing or making adjustments to the machine, stop the engine, set the parking brake, and remove the key to prevent someone from accidentally starting the engine.
- To make sure that the entire machine is in good condition, keep all nuts, bolts, and screws properly tightened.
- To reduce the potential for fire, keep the engine area free of excessive grease, grass, leaves, and accumulation of dirt.
- Never use an open flame to check the level or leakage of fuel or battery electrolyte.
- If the engine must be running to perform a maintenance adjustment, keep your hands, feet, clothing, and any parts of your body away from the engine and any moving parts. Keep everyone away.

- Do not use open pans of fuel or flammable cleaning fluids when cleaning parts.
- **Do not adjust** the traction control speed. To ensure safety and accuracy, have an Authorized Toro Distributor check the ground speed.
- Keep your body and hands away from pin hole leaks or nozzles that eject high pressure fluid. Use cardboard or paper to find leaks. Fluid escaping under pressure can penetrate skin and cause injury requiring surgery within a few hours by a qualified surgeon or gangrene may result.
- If major repairs are ever needed or assistance is required, contact an Authorized Toro Distributor.
- To be sure of optimum performance and safety, always purchase genuine Toro replacement parts and accessories. Replacement parts and accessories made by other manufacturers could be dangerous. Altering this sprayer in any manner that may affect sprayer operation, performance, durability, or its use, may result in injury or death. Such use could void the product warranty.

Safety and Instructional Decals



Safety decals and instructions are easily visible to the operator and are located near any area of potential danger. Replace any decal that is damaged or lost.

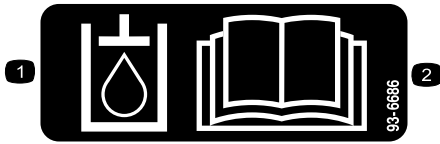

93-6686

decal93-6686

1. Hydraulic oil
2. Read the *Operator's Manual*.

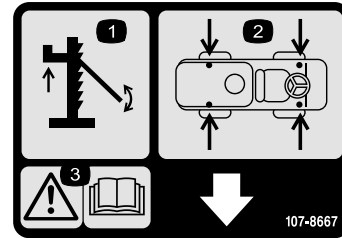

107-8667

decal107-8667

1. Jacking
2. Jack point locations
3. Warning—Read the *Operator's Manual* for more information on jacking the vehicle



106-5517

decal106-5517

1. Warning—do not touch the hot surface.

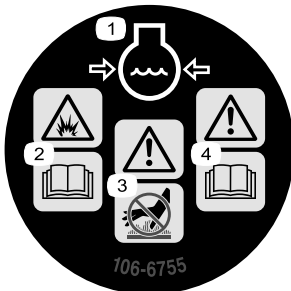

106-6755

decal106-6755

1. Engine coolant under pressure.
2. Explosion hazard—read the *Operator's Manual*.
3. Warning—do not touch the hot surface.
4. Warning—read the *Operator's Manual*.

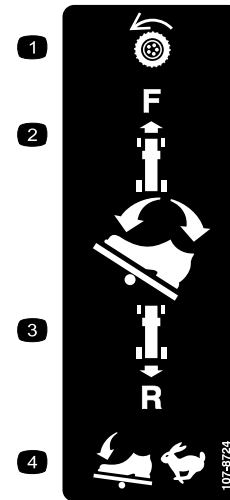

107-8724

decal107-8724

1. Traction drive
2. To drive forward, press the top of the traction pedal forward and down.
3. To drive in reverse, press the bottom of the pedal rearward and down.
4. Vehicle speed increases with more pedal pressure.

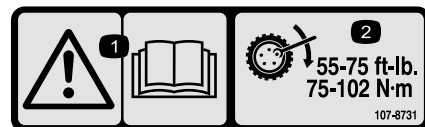

107-8731

decal107-8731

1. Warning—read the *Operator's Manual*.
2. Torque lug nuts to 75 to 102 N·m(55 to 75 ft-lb).

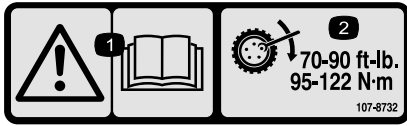

107-8732

decal107-8732

1. Warning—read the *Operator's Manual*.
2. Torque lug nuts to 95 to 122 N·m (75 to 90 ft-lb).

CALIFORNIA SPARK ARRESTER WARNING

Operation of this equipment may create sparks that can start fires around dry vegetation. A spark arrester may be required. The operator should contact local fire agencies for laws or regulations relating to fire prevention requirements. 117-2718

117-2718

decal117-2718



117-4955

decal117-4955

1. Warning—read the *Operator's Manual*; wear the seat belt when seated in the operator's position; avoid tipping the machine.
2. Warning—wear hearing protection.

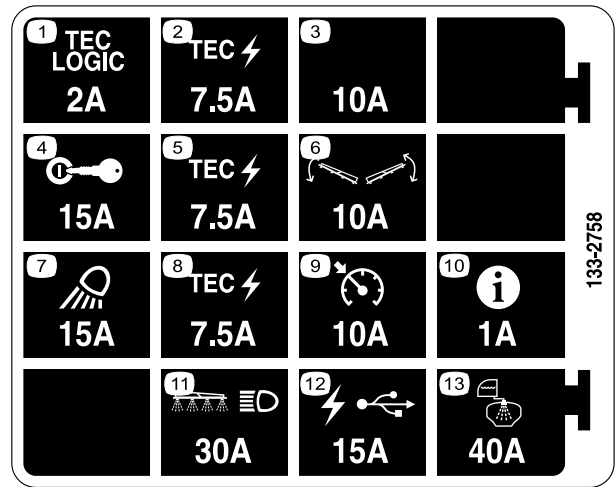

133-2758

decal133-2758

- | | |
|-------------------------|-----------------------------|
| 1. Tec Logic—2 A | 8. Tec power—7.5 A |
| 2. Tec power—7.5 A | 9. Cruise control—10 A |
| 3. Extra fuse slot—10 A | 10. InfoCenter—1 A |
| 4. Ignition—15 A | 11. Boom and headlight—30 A |
| 5. Tec power—7.5 A | 12. USB power—15 A |
| 6. Boom control—10 A | 13. Tank spray—40 A |
| 7. Work light—15 A | |

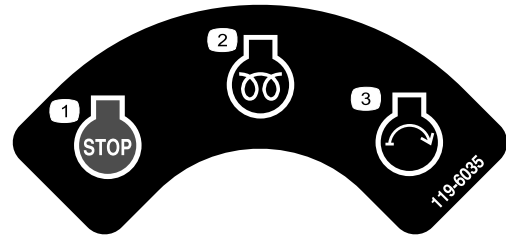

119-6035

decal119-6035

- | | |
|------------------------|-----------------|
| 1. Engine—stop | 3. Engine—start |
| 2. Engine—run, preheat | |

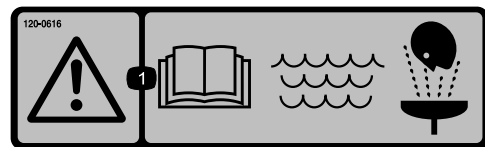

120-0616

decal120-0616

1. Warning—read the *Operator's Manual*; use fresh, clean water for first-aid washing.



120-0622

decal120-0622

1. Warning—read the *Operator's Manual*.
2. Warning—do not enter the tank.
3. Caustic liquid/chemical burn and toxic gas inhalation hazards—wear hand, skin, eye, and respiratory protection.

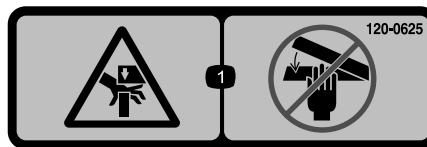

120-0625

decal120-0625

1. Pinch point, hand—keep hands away.



107-8722

decal107-8722

1. Engaging the parking brake—1) Push down on the parking brake pedal; 2) Pull down on the parking brake lever to lock the parking brake.

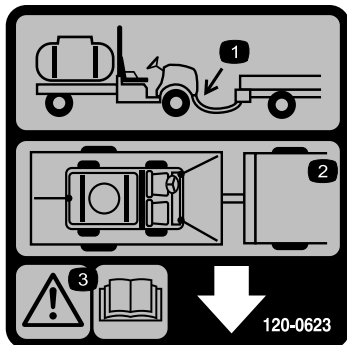

120-0623

decal120-0623

1. Tow hitch location
2. Tie down locations
3. Warning—Read the *Operator's Manual*.



120-0617

decal120-0617

1. Pinch point—keep hands away from the hinge.
2. Crushing hazard, boom—keep bystanders away.

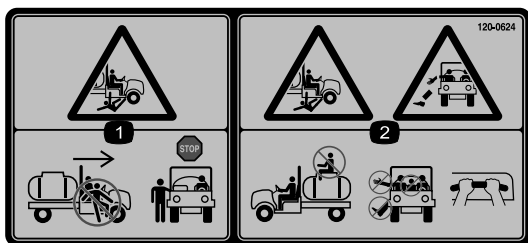

120-0624

decal120-0624

1. Crushing/dismemberment hazard of bystanders—do not exit or enter the machine while it is moving; stop the machine before entering or exiting.
2. Falling, crushing hazard—no riders on tank; keep arms and legs inside of the vehicle at all times, use passenger hand holds.

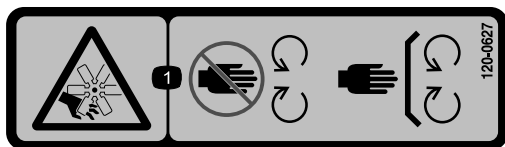

120-0627

decal120-0627

1. Cutting/dismemberment hazard, fan—stay away from moving parts, keep all guards and shields in place.

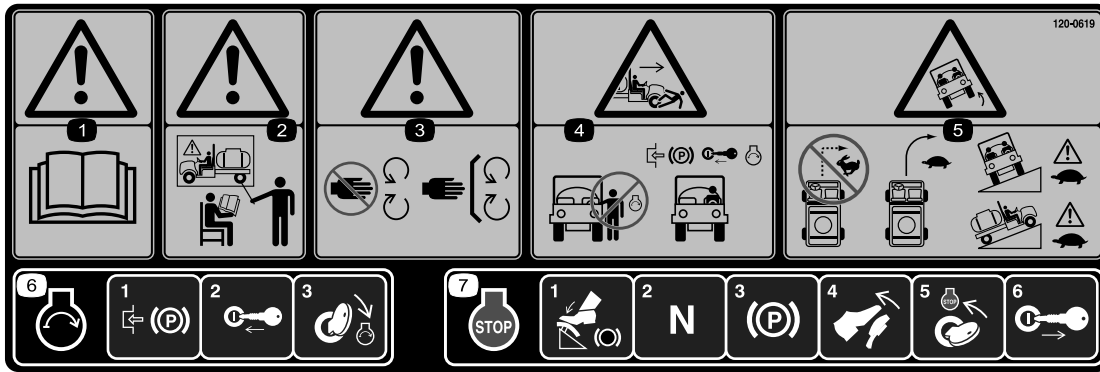

120-0619

decal120-0619

1. Warning—read the *Operator's Manual*.
2. Warning—do not operate this machine unless you are trained.
3. Warning—stay away from moving parts, keep all guards and shields in place.
4. Crushing/dismemberment hazard of bystanders—do not start the engine while entering or exiting the vehicle; engage the parking brake, insert the key, and start the engine while seated in the driver's seat.
5. Tipping hazard—do not turn sharply while traveling fast, drive slowly when turning; use caution and drive slowly when traveling across or up and down slopes.
6. To start the engine, engage the parking brake, insert the ignition key and turn it to the start position.
7. To stop the engine, press the brake, ensure that the traction pedal is in the Neutral position, set the parking brake, release the brake, stop the engine, and remove the key.



127-6976

decal127-6976

1. Decrease
2. Increase

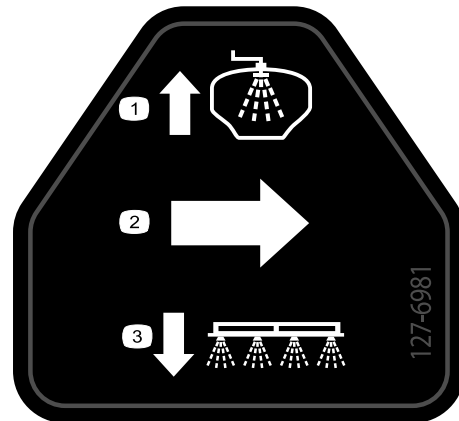

127-6981

decal127-6981

1. Bypass-return flow
2. Flow
3. Boom spray

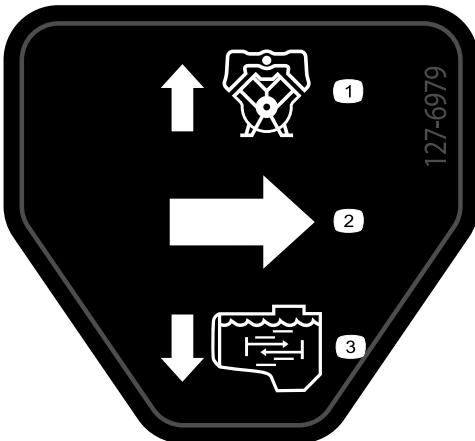

127-6979

decal127-6979

1. Pump-return flow
2. Flow
3. Agitation flow

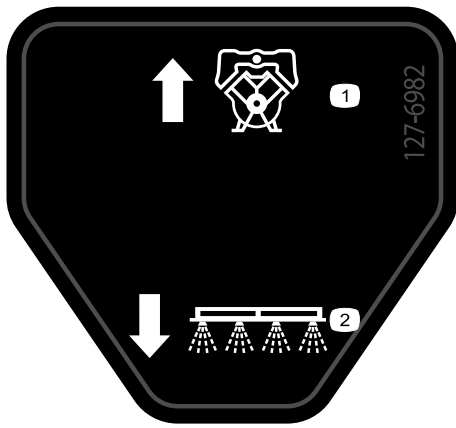

127-6982

decal127-6982

- 1. Pump-return flow
- 2. Boom spray

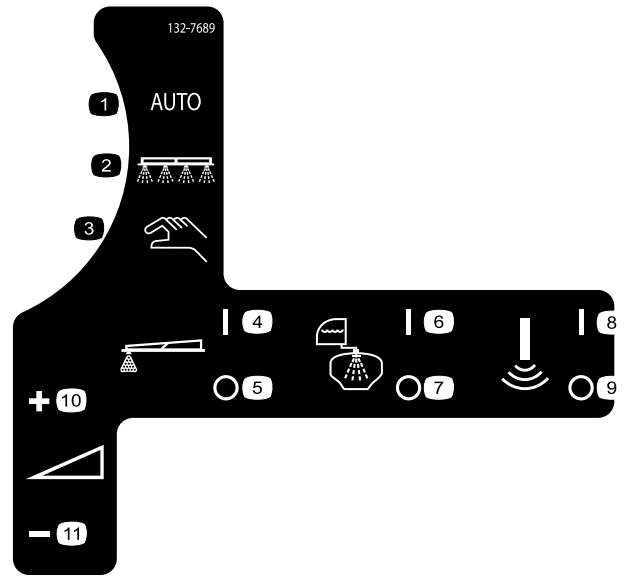

132-7689

decal132-7689

- 1. Auto
- 2. Spray mode
- 3. Manual spray mode
- 4. Foam marker—on
- 5. Foam marker—off
- 6. Rinse system—on
- 7. Rinse system—off
- 8. Sonic sensor—on
- 9. Sonic sensor—off
- 10. Application rate—increase
- 11. Application rate—decrease



130-7076

decal130-7076

- 1. Neutral engine speed lock
- 2. On
- 3. Off

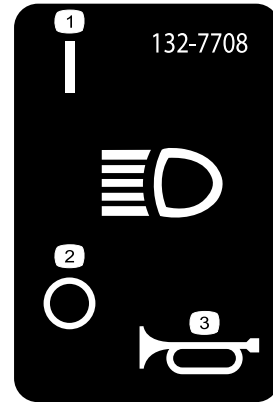

132-7708

decal132-7708

- 1. Headlight—on
- 2. Headlight—off
- 3. Horn



132-7786

decal132-7786

- 1. Spray—off
- 2. Spray—on
- 3. USB

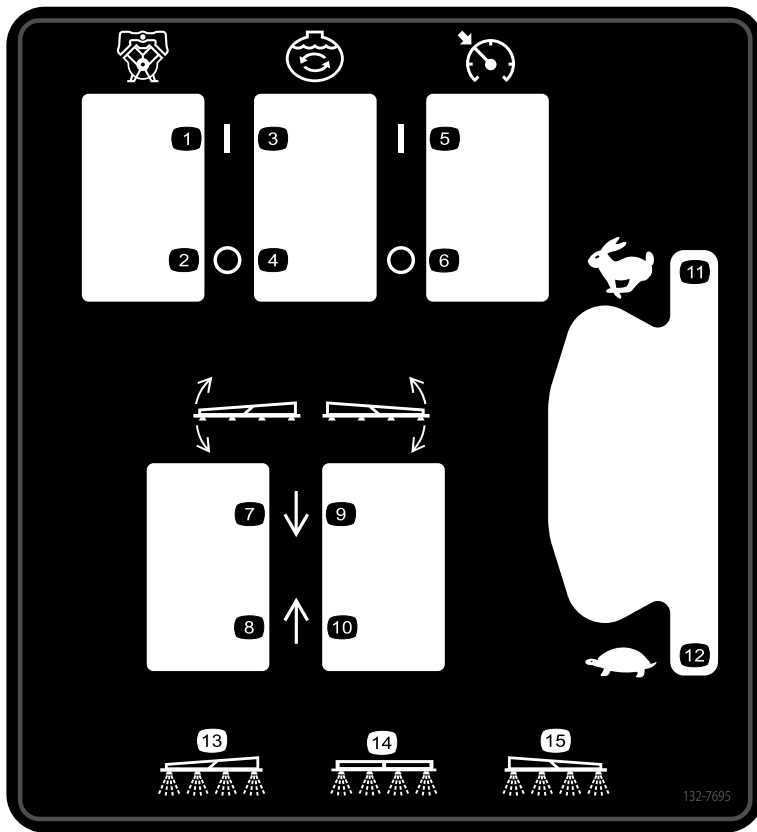

decal132-7695

132-7695

- | | | | |
|------------------|-------------------------|---------------------------|-----------------------|
| 1. Pump—on | 5. Speed control—on | 9. Lower the right boom. | 13. Left boom spray |
| 2. Pump—off | 6. Speed control—off | 10. Raise the right boom. | 14. Center boom spray |
| 3. Agitation—on | 7. Lower the left boom. | 11. Engine speed—fast | 15. Right boom spray |
| 4. Agitation—off | 8. Raise the left boom. | 12. Engine speed—slow | |

Setup

Loose Parts

Use the chart below to verify that all parts have been shipped.

Procedure	Description	Qty.	Use
1	No parts required	–	Check the boom-hinge springs.
2	No parts required	–	Remove the shipping bumper.

Media and Additional Parts

Description	Qty.	Use
Starter key	2	Read the manuals and watch the training materials before operating the machine.
Operator's Manual	1	
Engine Owner's Manual	1	
Parts Catalog	1	
Operator Training Materials	1	
Screen filter	2	

Note: Determine the left and right sides of the machine from the normal operating position.

Note: If you have questions or need additional information regarding the spray control system, refer to the *Operator's Manual* supplied with the system.

Important: This sprayer is sold without nozzles.

To use the sprayer, you must obtain and install nozzles. Contact your Authorized Toro Distributor for information on the available boom kit and accessories.

After you install your nozzles and before using the sprayer for the first time, adjust the boom bypass valves so that the pressure and application rate remains the same for all booms when you turn one or more booms off. Refer to **Calibrating the Boom Bypass Valves** section in the **Operation** section.

1

Checking the Boom-Hinge Springs

No Parts Required

Procedure

Important: Operating the spray system with the boom hinge springs under the incorrect compression could damage the boom assembly. Measure the springs and use the jam nut to compress the springs to 3.96 cm (1.56 inches), if necessary.

The sprayer may be shipped with the boom extensions swung forward to facilitate packaging of the machine. The springs are not fully tightened at the time of

manufacture to allow the booms to be in this position for transit. Before operating the machine, adjust the springs to the correct compression.

1. If necessary, remove the packing components that secure the right and left extension booms during shipping.
2. Support the booms while they are extended to the spray position.
3. At the boom hinge, measure the compression of the upper and lower springs while the booms are in their extended position ([Figure 3](#)).
 - A. Compress all springs until they measure 3.96 cm (1.56 inches).
 - B. Use the jam nut to compress any spring that measure greater than 3.96 cm (1.56 inches).

2

Removing the Shipping Bumper

No Parts Required

Procedure

1. Remove the bolts, washers, and nuts that secure the shipping bumper to the front chassis plate (Figure 4).

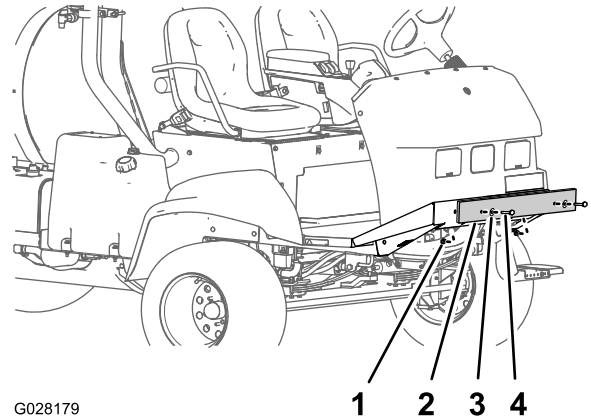

G028179

g028179

Figure 4

- | | |
|--------------------|-----------|
| 1. Nut | 3. Washer |
| 2. Shipping bumper | 4. Bolt |

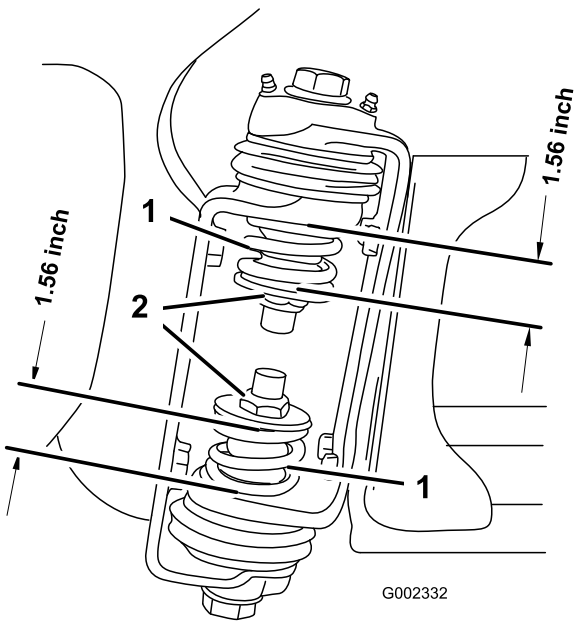

G002332

g002332

Figure 3

- | | |
|----------------------|------------|
| 1. Boom-hinge spring | 2. Jam nut |
|----------------------|------------|
-
4. Repeat the procedure for each spring on both boom hinges.
 5. Move the booms into the transport "X" position; refer to [Operating the Booms \(page 41\)](#).

2. Remove the shipping bumper from the machine (Figure 4).

Note: Discard the bolts, washers, nuts, and shipping bumper.

Product Overview

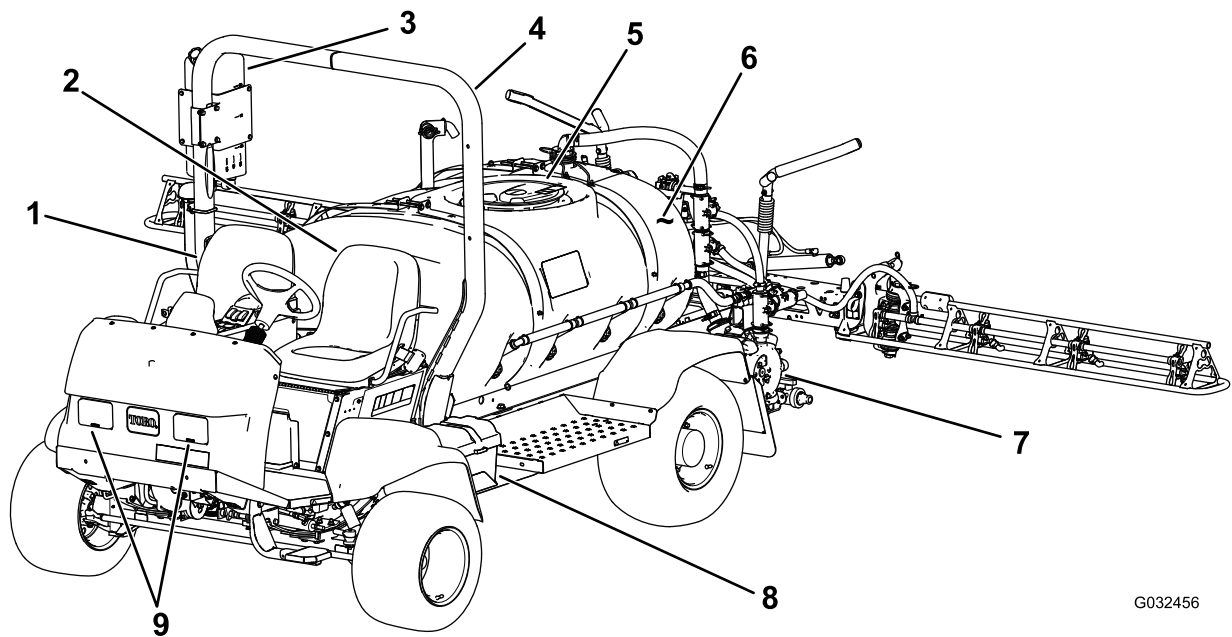

G032456

g032456

Figure 5

- | | | |
|---------------------|--------------------------------------|----------------|
| 1. Passenger seat | 4. Rollover Protection System (ROPS) | 7. Pump |
| 2. Operator's seat | 5. Tank lid | 8. Battery |
| 3. Fresh-water tank | 6. Chemical tank | 9. Work lights |

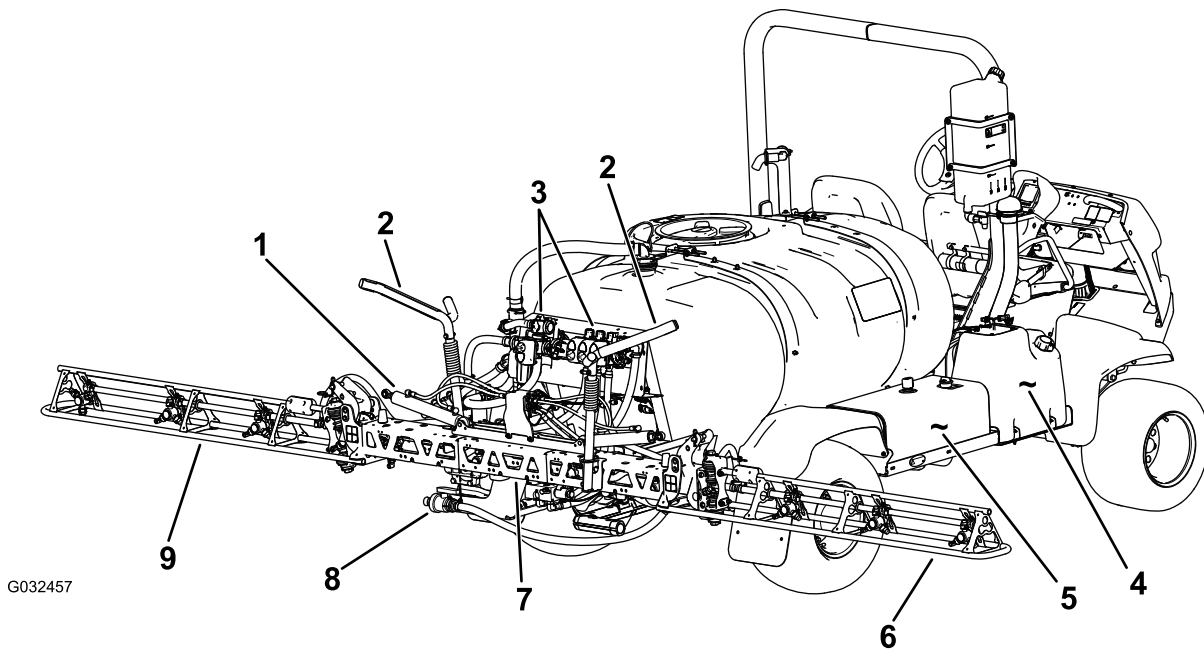

G032457

g032457

Figure 6

- | | | |
|--------------------------|-----------------------|------------------------|
| 1. Boom-control cylinder | 4. Fuel tank | 7. Center boom section |
| 2. Boom-transport cradle | 5. Hydraulic tank | 8. Tank drain valve |
| 3. Valve manifolds | 6. Right boom section | 9. Left boom section |

Controls

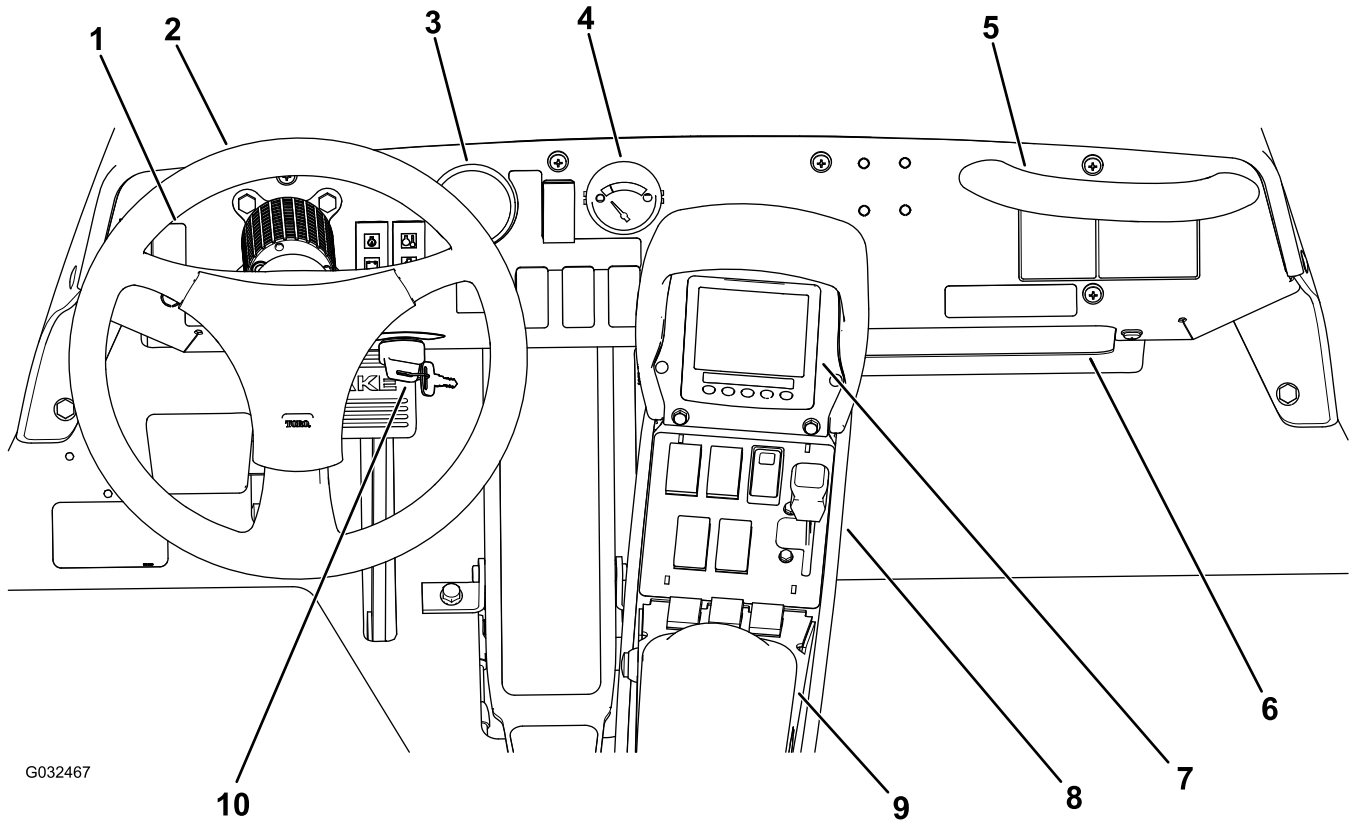

G032467

g032467

Figure 7

- | | |
|------------------------|------------------------|
| 1. Work-light switch | 6. Storage compartment |
| 2. Steering wheel | 7. InfoCenter |
| 3. Pressure gauge | 8. Quick Find™ console |
| 4. Fuel gauge | 9. Arm rest |
| 5. Passenger-hand hold | 10. Ignition switch |

Vehicle Controls

Traction Pedal

The traction pedal ([Figure 8](#)) controls the movement of the machine, both forward and reverse. Using the heel and toe of the right foot, press the top of the pedal to move forward or the bottom of the pedal to move the machine in reverse. Release the pedal to slow and stop the machine.

Important: Ensure that you allow the sprayer to come to a stop before switching between the Forward and the Reverse positions.

Note: The farther you press the pedal in either direction, the faster the sprayer will travel. To obtain maximum forward speed, set the throttle lever to the FAST position and press the traction pedal all the way forward.

Note: To get maximum power under heavy load or when ascending a hill, have the throttle in the FAST

position while pressing traction pedal slightly to keep the engine speed high. When the engine speed begins to decrease, release the traction pedal slightly to allow the engine speed to increase.

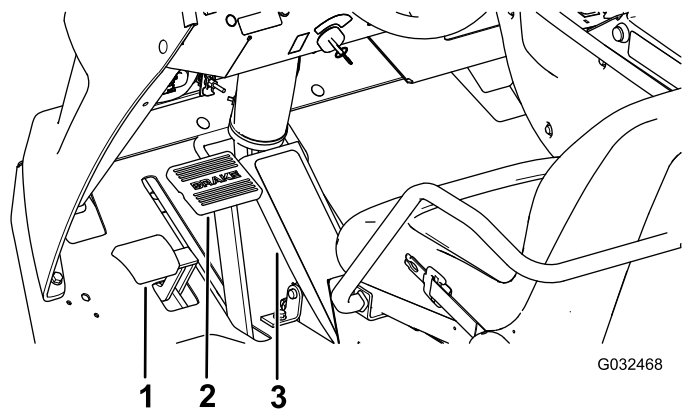

Figure 8

- 1. Parking-brake pedal
- 2. Brake pedal
- 3. Traction pedal

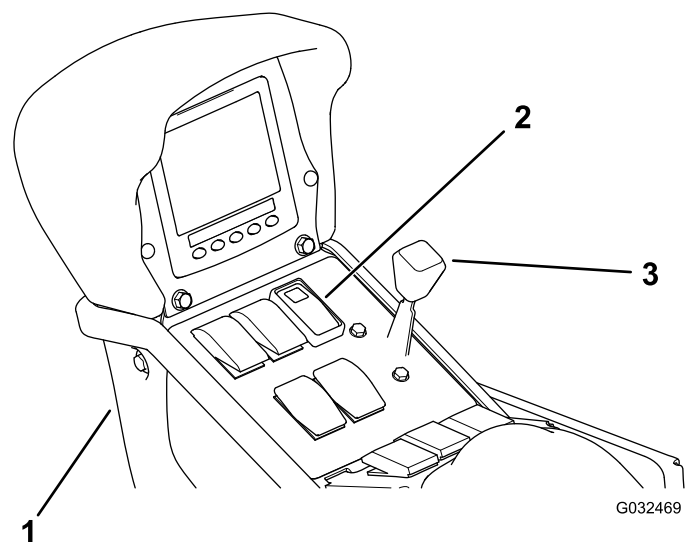

Figure 9

- 1. Center console
- 2. Speed-lock switch
- 3. Throttle lever

Brake Pedal

Use the brake pedal to stop or slow the machine (Figure 8).

CAUTION

If you operate the sprayer with poorly adjusted or worn brakes, you could lose control of the sprayer, resulting in serious injury or death to you or bystanders.

Always check the brakes before operating the sprayer and keep them properly adjusted and repaired.

Parking Brake

The parking brake is a pedal to the left of the brake (Figure 8). Engage the parking brake whenever you leave the seat to prevent the sprayer from accidentally moving. To engage the parking brake, press the brake pedal, and, while holding the brake, press the parking-brake pedal. To disengage, press and release the brake pedal. If the sprayer is parked on a steep grade, apply the parking brake and place blocks on the downhill side of the wheels.

Ignition Switch

The ignition switch (Figure 7), used to start and stop the engine, has 3 positions: OFF, ON/PREHEAT, and START.

Speed-Lock Switch

The speed-lock switch locks the position of the traction pedal at the time that the switch is set (Figure 9). This ensures that the sprayer travels at a constant speed while driving the machine on level ground.

Throttle Lever

The throttle lever, located on the control panel between the seats (Figure 9), controls the speed of the engine. Push the lever forward to increase the engine speed and pull it rearward to decrease the engine speed.

Work-Light Switch

Toggle the switch to operate the work lights (Figure 7). Push it forward to turn the lights on and rearward to turn them off.

Fuel Gauge

The fuel gauge on the dash of the machine and displays the level of the fuel in the tank (Figure 7).

Sprayer Controls

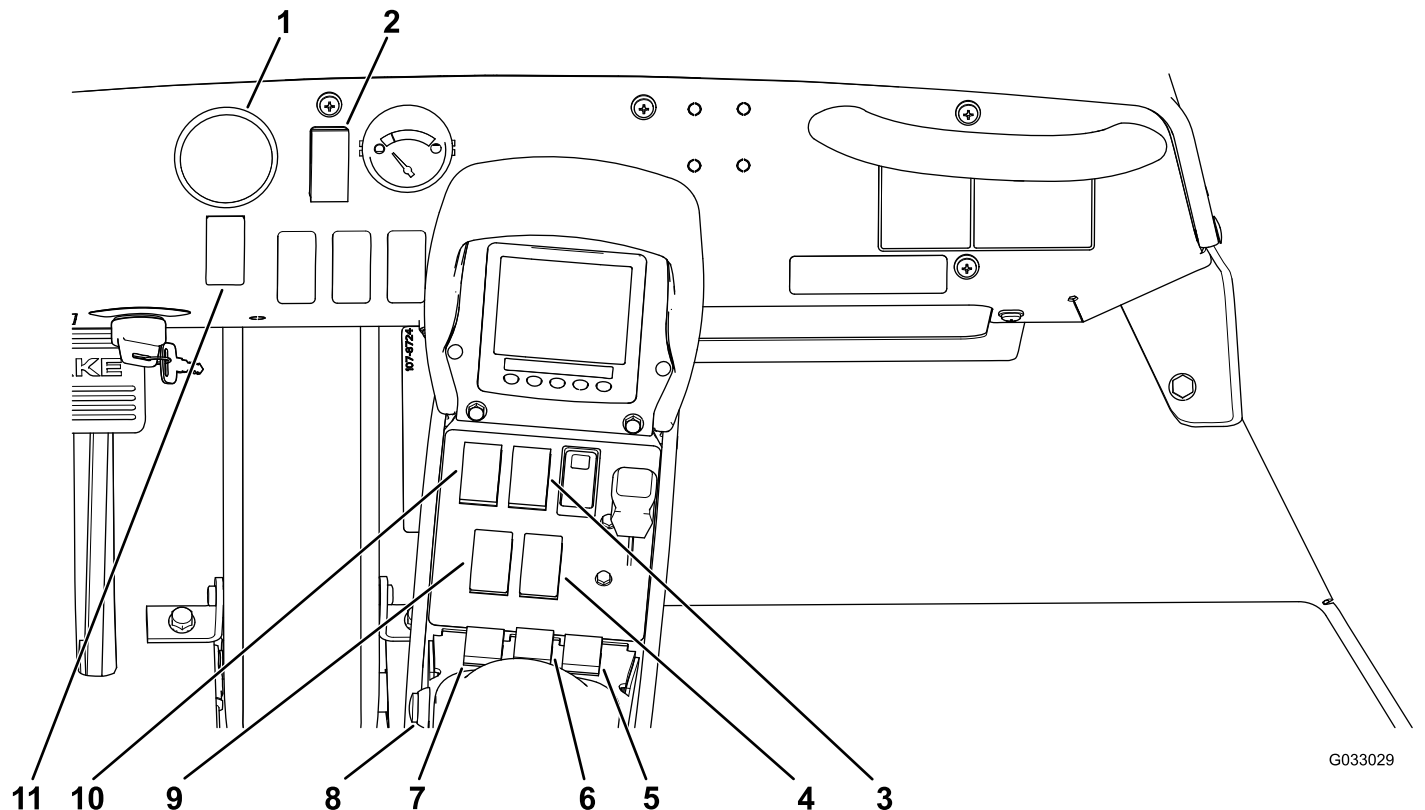

Figure 10

- | | |
|----------------------------------|---------------------------------|
| 1. Pressure gauge | 7. Left boom switch |
| 2. Spray-mode switch | 8. Master boom switch |
| 3. Tank-agitation switch | 9. Left raise/lower-boom switch |
| 4. Right raise/lower-boom switch | 10. Pump switch |
| 5. Right boom switch | 11. Application-rate switch |
| 6. Center boom switch | |

Application-Rate Switch

The application-rate switch is located on the dash to the right of the steering wheel (Figure 10). Press and hold the switch forward to increase the application rate (pressure), or press and hold it rearward to decrease the application rate (pressure).

Pressure Gauge

The pressure gauge (Figure 10) is located on the dash. This gauge shows the pressure of the fluid in the spray system in psi and kPa.

Master Boom Switch

The master boom switch is located on the center console of the machine. It allows you to start or stop the spray operation. Press the switch to enable or disable the spray system (Figure 10).

Boom-Section Switches

The boom-section switches are located on the center console in the front of the arm rest (Figure 10). Toggle each switch forward to turn the corresponding boom section on and rearward to turn each off. When the switch is in the ON position, an icon appears on the InfoCenter.

Note: These switches will only affect the spray system when the master boom switch is in the ON position.

Pump Switch

The pump switch is located on the center console to the right of the seat (Figure 10). Toggle this switch forward to run the pump or rearward to stop the pump.

Important: Engage the pump switch only when the engine is at LOW IDLE to avoid damaging the pump drive.

Raise/Lower-Boom Switch

The raise/lower-boom switches are located on the center console to the right of the seat and used to raise or lower the left and right booms (Figure 10).

Agitation Switch

The agitation switch is located on the center console to the right of the seat (Figure 10). Toggle this switch forward to turn on the agitation in the tank or rearward to stop the agitation. When the switch is turned on, a light on the switch illuminates. To operate the agitation function, you must run the sprayer system pump and you must run the engine above low idle. The agitation valve is located behind the tank (Figure 11).

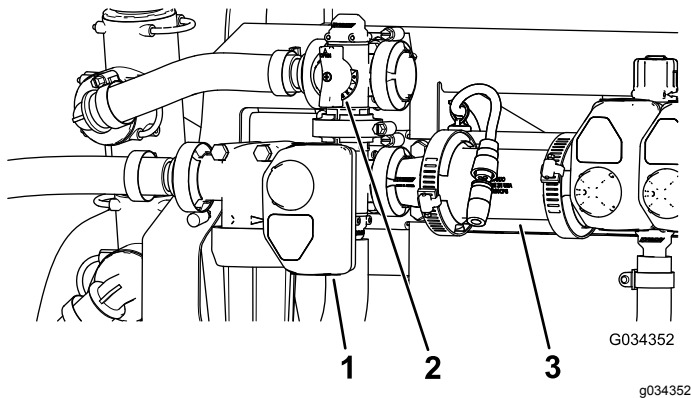

Figure 11

1. Actuator (agitation valve)
2. Agitation-bypass-valve handle
3. Flow meter

Agitation-Bypass Valve

The agitation-bypass valve redirects the flow of fluid to the sprayer-system pump when you turn off the agitation function (Figure 11). The agitation-bypass valve is located above the agitation valve. You can adjust the bypass valve to ensure that the pressure remains constant when cycling agitation on or off; refer to [Calibrating the Agitation-Bypass Valve \(page 45\)](#).

Agitation-Throttle Valve

The agitation-throttle valve is a manually-operated ball valve that controls flow to the agitation nozzles in the main tank. This valve allows the user to control the sprayer-system pressure at the agitation nozzles of the main tank when larger application rates are required. The agitation-throttle valve is located above the pump (Figure 12).

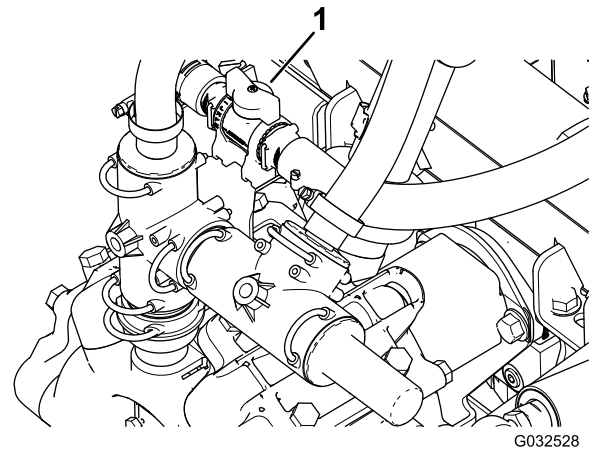

Figure 12

1. Agitation-throttle-valve handle

Boom-Section Valves

The section valves control flow to the 3 boom sections and they can be turned on or off (Figure 13).

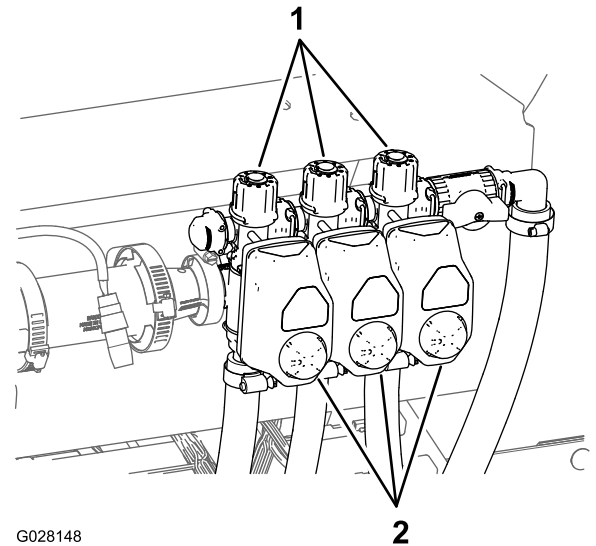

Figure 13

1. Knob (section-bypass valve)
2. Actuators (section valve)

Boom-Section-Bypass Valve

Manual Mode Only

The boom bypass redirects the fluid flow for a boom section to the tank when you turn off the boom section. You can adjust the boom bypass to ensure that the boom pressure remains constant no matter how many boom sections are on.

Flowmeter

The flowmeter measures the flow rate of the fluid for use by the InfoCenter system (Figure 11).

Anti-Siphon Fill Receptacle

Located toward the front of the tank cover, is a hose receptacle with a threaded fitting, a 90-degree barbed fitting, and a short hose, which you can direct toward the tank opening. This receptacle allows you to connect a water hose to it and fill the tank with water without contaminating the hose with the chemicals in the tank.

Important: Do not lengthen the hose to allow contact with the tank fluids. The distance from the end of the hose to the uppermost water level should be within local regulatory limits.

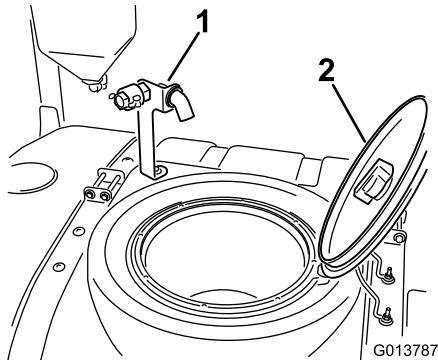

g013787

Figure 14

1. Anti-siphon fill receptacle 2. Tank cover

Tank Cover

The tank cover is located in the center of the top of the tank. To open it, turn off the engine, then turn the front half of the cover to the left and swing it open. You can remove the strainer inside for cleaning. To seal the tank, close the cover and rotate the front half toward the right.

InfoCenter Home Screen

When you start the machine, the home screen appears, displaying the corresponding icons that apply (i.e., the parking brake is engaged, the boom sections are in the On position, the operator is out of the seat, etc.).

Note: The following figure is an example screen; this screen is meant to show all of the **potential** icons that could appear on the screen while operating.

Refer to the following graphic for all of the icon meanings (Figure 15).

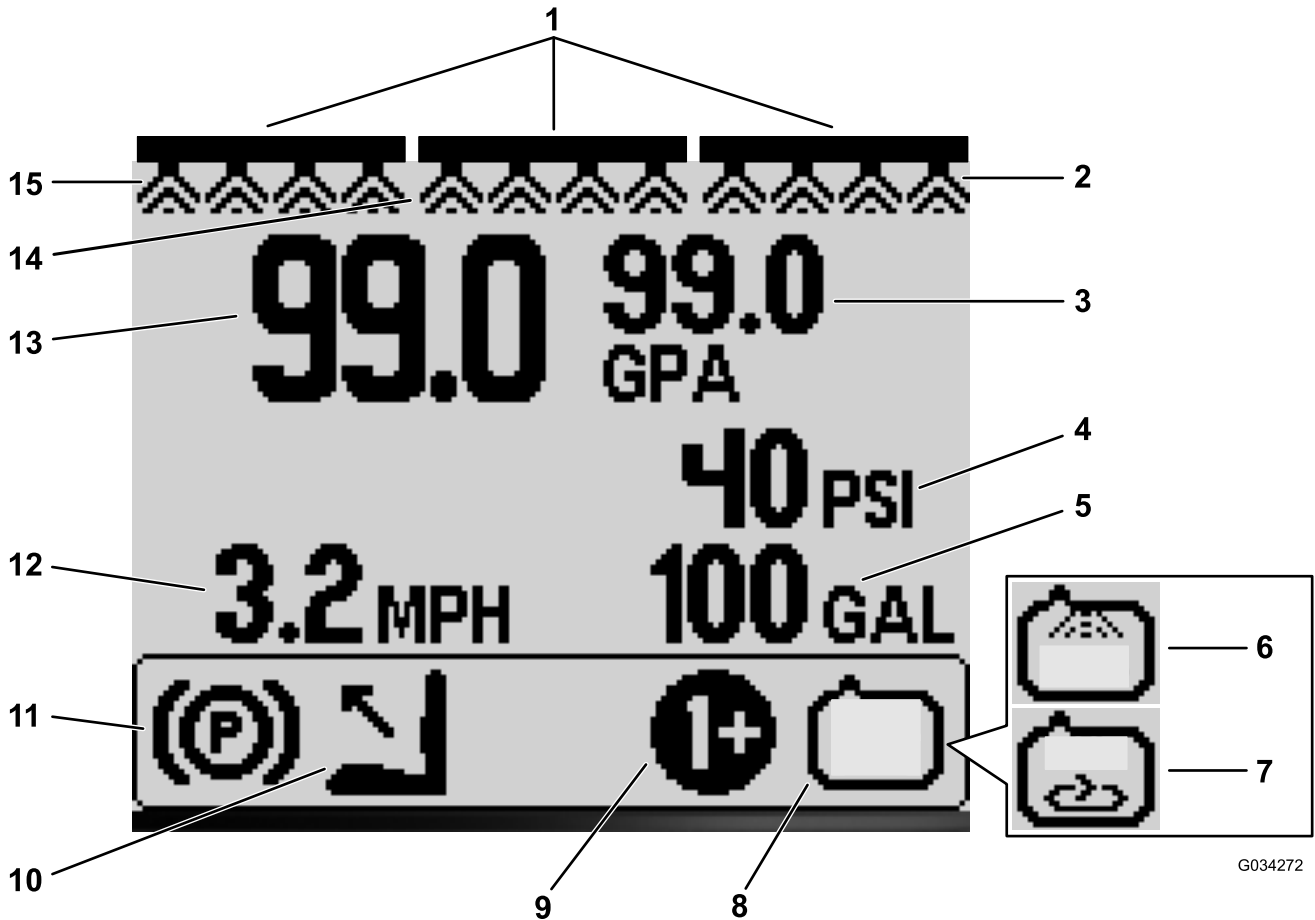

Figure 15

- | | | | |
|------------------------------------|---|--|--------------------------------------|
| 1. Master boom-switch indicator—on | 5. Tank-volume indicator (US gallons) | 9. Selected-application rate/boost-rate indicator—on | 13. Active-application rate (gpa) |
| 2. Right boom-section indicator—on | 6. Rinse-system indicator—on (optional kit) | 10. Operator out of seat | 14. Center boom-section indicator—on |
| 3. Target-application rate (gpa) | 7. Agitation indicator—on | 11. Parking-brake indicator | 15. Left boom-section indicator—on |
| 4. System-pressure indicator (psi) | 8. Spray-pump indicator—on | 12. Vehicle-speed indicator (mph) | |

Master Boom-Switch Indicator

The master boom-switch indicator displays when the master boom is in the ON position (Figure 15).

Boom-Sections Indicator

The left, right, and/or center boom sections display when any of the boom sections are in the ON position (Figure 15).

Active-Application Rate

The active-application rate indicates the actual rate at which the sprayed product is being applied (Figure 15).

Target-Application Rate

The target-application rate indicates the target rate that the user desires when operating in the application-rate mode (Figure 15).

Note: In Auto mode, the target-application rate should align with the active-application rate.

Vehicle-Speed Indicator

The vehicle-speed indicator displays the current vehicle speed (Figure 15).

System-Pressure Indicator

When in Auto mode and the boom sections are active (on), the system-pressure indicator displays the spray pressure; when the boom sections are off, the agitation pre-set pressure displays (Figure 15).

Parking-Brake Indicator

The parking-brake indicator displays when the parking brake is engaged (Figure 15).

Operator's-Seat Indicator

The operator-seat indicator displays when the operator is out of the seat (Figure 15).

Selected-Application Rate/Boost-Rate Indicator

The selected-application rate/boost-rate indicator displays when either the selected-application rate and/or the boost rate are active (Figure 15).

Spray-Pump Indicator

The spray-pump indicator displays when the spray pump is on (Figure 15).

Rinse-System Indicator

Optional Kit

The rinse-system indicator displays when the rinse system is active (Figure 15).

Agitation Indicator

The agitation indicator displays when agitation is on (Figure 15).

InfoCenter Main Menu Screen

Press and hold the button 5 (far right) on the InfoCenter to access the Main Menu screen.

From the Main Menu screen, you can access the Set Rates screen, Settings screen, Calibration screen, Service screen, Diagnostics screen, or the About screen (Figure 16).

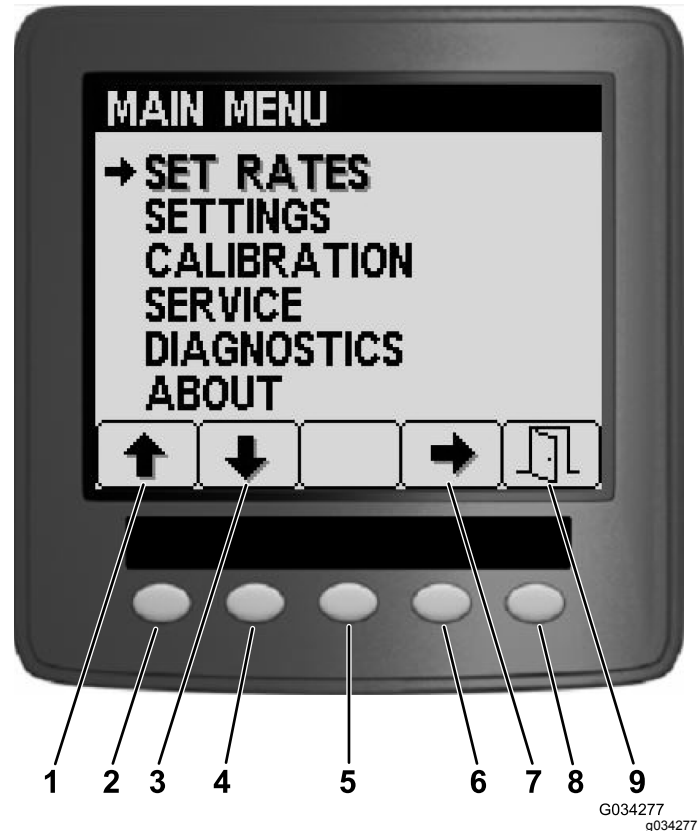

Figure 16

- | | |
|---------------|-----------------|
| 1. Up arrow | 6. Button 4 |
| 2. Button 1 | 7. Select arrow |
| 3. Down arrow | 8. Button 5 |
| 4. Button 2 | 9. Exit |
| 5. Button 3 | |

Set Rates Screen

To access the Set Rates screen, press button 2 on the Main Menu screen (Figure 16) until you reach Set Rates and press button 4 to select Set Rates (Figure 17).

This screen displays and allows you to set the Target Rate, Rate 1, Rate 2, and the Boost-rate percentage.

To set Rate 1, Rate 2, or the Boost-rate percentage, refer to the following:

1. Press button 1 or 2 until you reach the desired rate or boost-rate percentage (Figure 17).
2. Press button 4 to select or edit the rate.

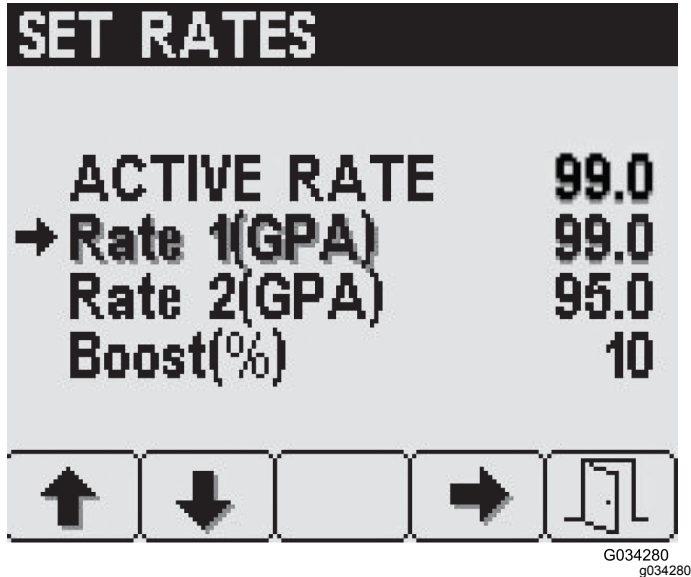

Figure 17

3. In the screen for the selected rate, use buttons 3 and 4 to set the desired rate (Figure 18).

Note: You can change the rate faster by pressing and holding button 3 or 4.

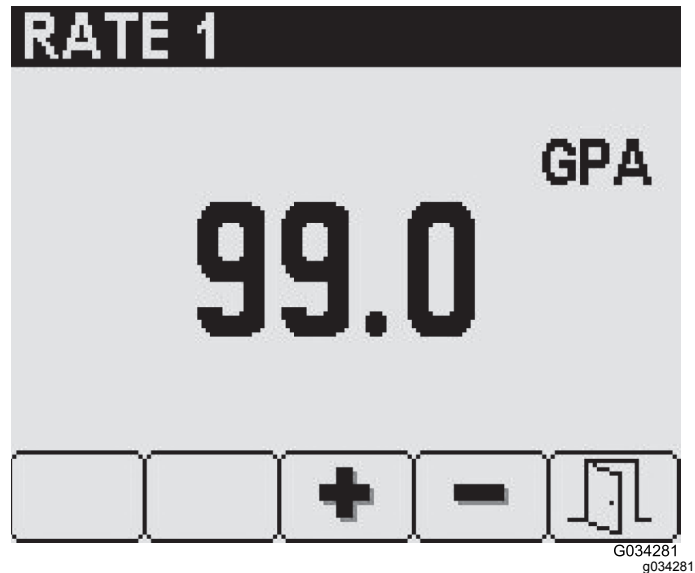

Figure 18

Note: From the home screen, press and hold buttons 1 and 2 simultaneously to select Rate 1 or press and hold buttons 4 and 5 simultaneously to select Rate 2.

Note: From the Home screen, press and hold buttons 1 and 5 simultaneously to apply boost rate.

Boost is active only as long as you hold buttons 1 and 5, then returns the set rate when you no longer press and hold the buttons.

4. Press button 5 to exit the Set Rates screen, to save the rate setting, and return to the Main screen.

Settings Screen

To access the Settings screen, press button 2 on the Main Menu screen (Figure 16) until you reach Settings and press button 4 to select Settings (Figure 19).

This screen allows you to view and change the settings for the tank, display, boom width, and to reset default settings.

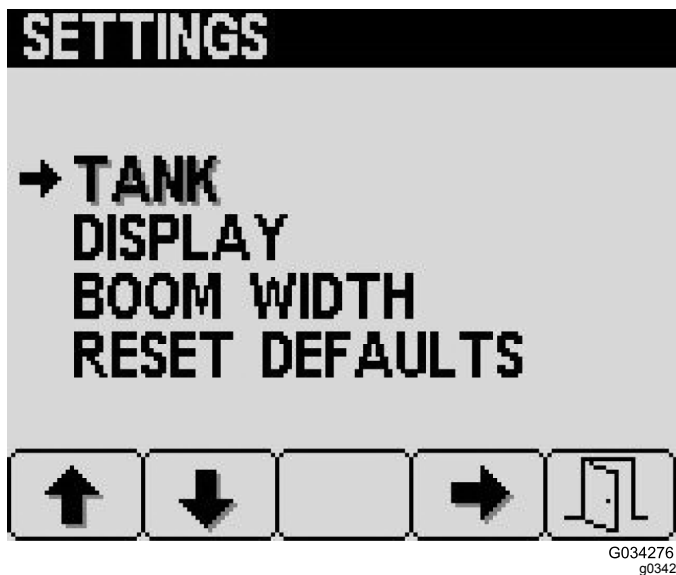

Figure 19

Changing the Tank Settings

1. Press button 4 on the Settings screen to select Tank settings (Figure 19).
2. Press button 2 until you reach the item that you would like to change (Figure 20).
3. Use buttons 3 and 4 to set the desired value (Figure 20).

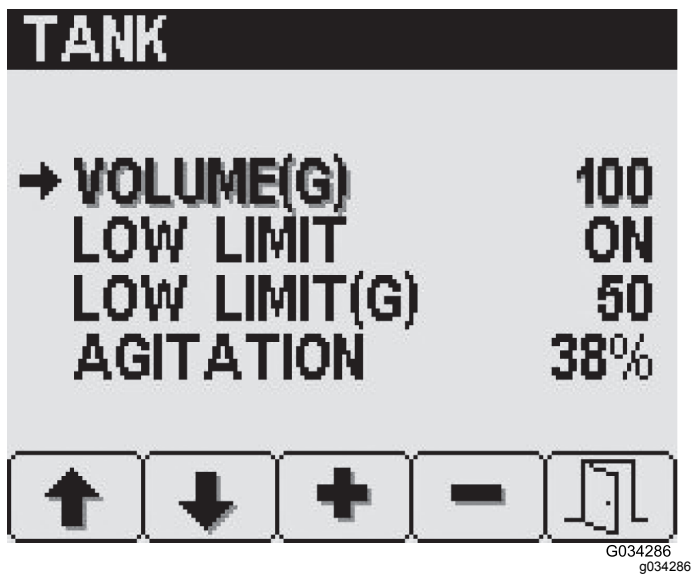

Figure 20

Note: Volume indicates the current amount of liquid in the tank. The low-limit setting alerts you when the tank volume has fallen below the specified low-limit-tank volume. This setting can be turned on or off. You can increase or decrease agitation by pressing buttons 3 and 4.

Changing Unit of Measure

1. Press button 2 on the Settings screen until you reach Display settings and then press button 4 to select Display (Figure 19).
2. Press button 1 or 2 until you reach Units and then press button 4 to select Units.
3. Press button 1 or 2 until you reach the desired unit and then press button 4 to select this unit.
 - **English:** mph, gallons, acre
 - **Turf:** mph, gallons, 100 ft²
 - **SI (metric):** kph, liter, hectare

Changing the Display Backlight or Contrast

1. Press button 2 on the Display settings screen until you reach Backlight or Contrast (Figure 21).
2. Use buttons 3 and 4 to set the desired value (Figure 21).

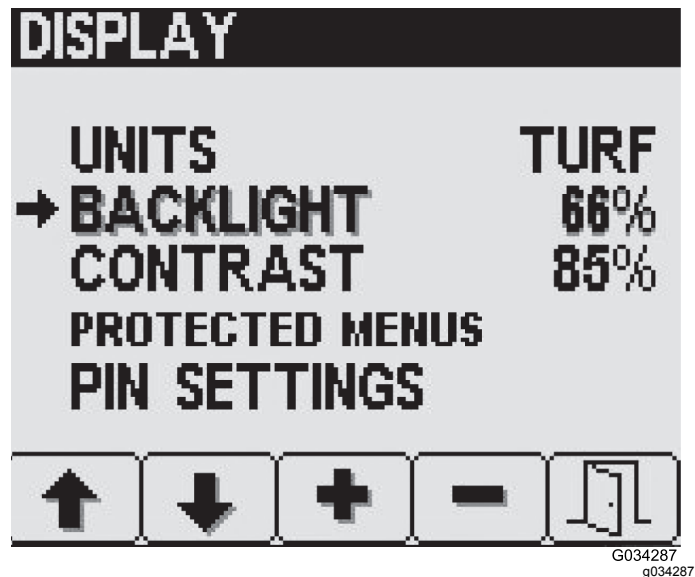

Figure 21

Changing the InfoCenter Protected Menus

1. Press button 2 on the Display settings screen until you reach Protected Menus, then press button 4 to select Protected Menu (Figure 22).

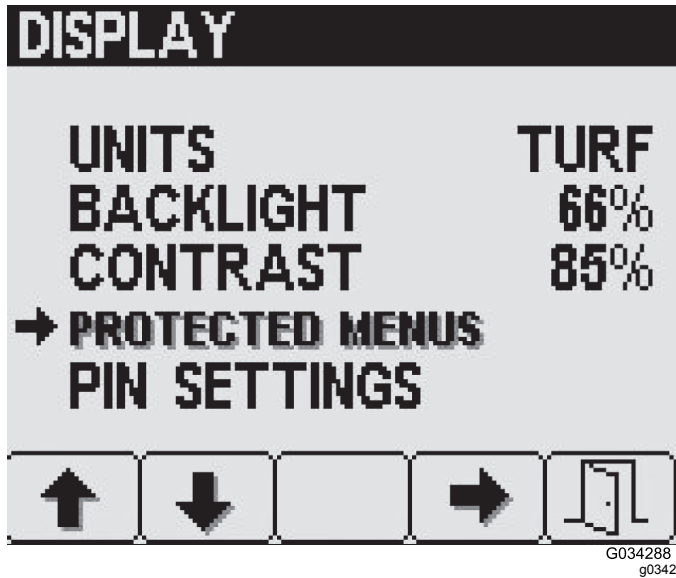

Figure 22

2. Press button 2 until you reach the desired protected menu item (Figure 23).
3. Press button 4 to select and deselect each protected menu item (Figure 23).

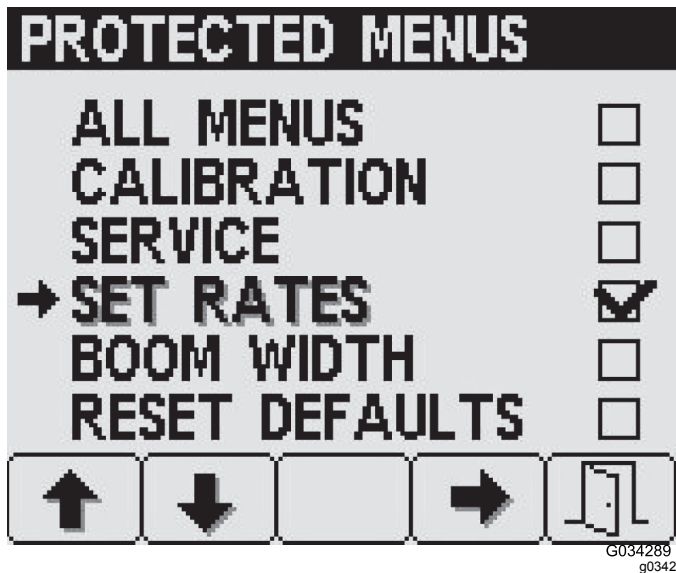

Figure 23

Turning the InfoCenter PIN On or Off

1. Press button 2 on the Display settings screen until you reach PIN Settings, then press button 4 to select PIN Settings (Figure 24).

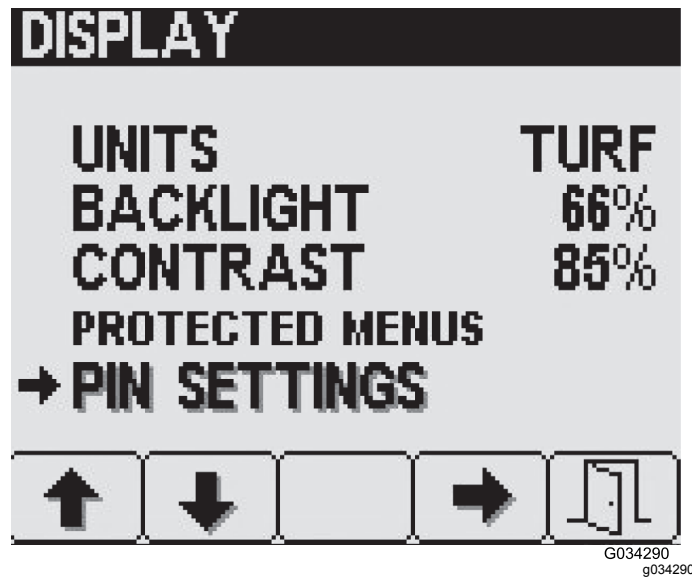

Figure 24

2. Enter your PIN using buttons 1 to 4 and press button 5 when you complete the PIN (Figure 25).

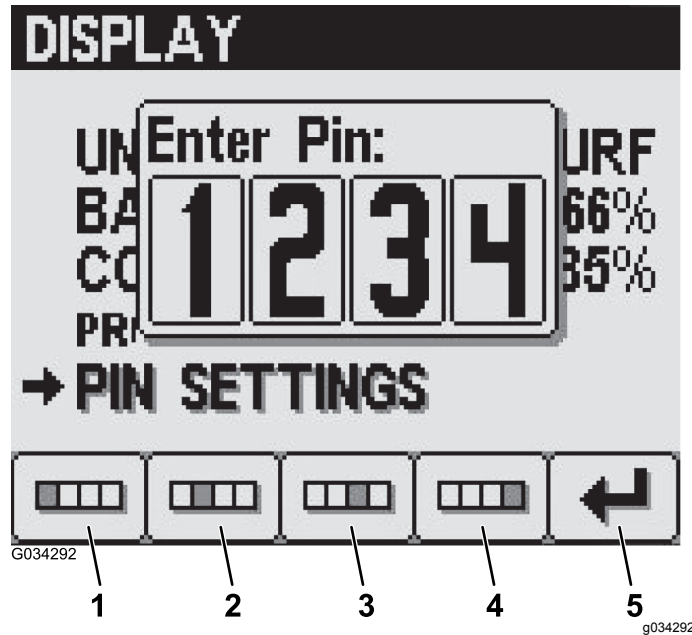

Figure 25

1. Digit 1
2. Digit 2
3. Digit 3
4. Digit 4
5. Enter PIN

3. From the PIN Settings screen, press button 4 to select PIN Entry and to turn the PIN on or off (Figure 26).

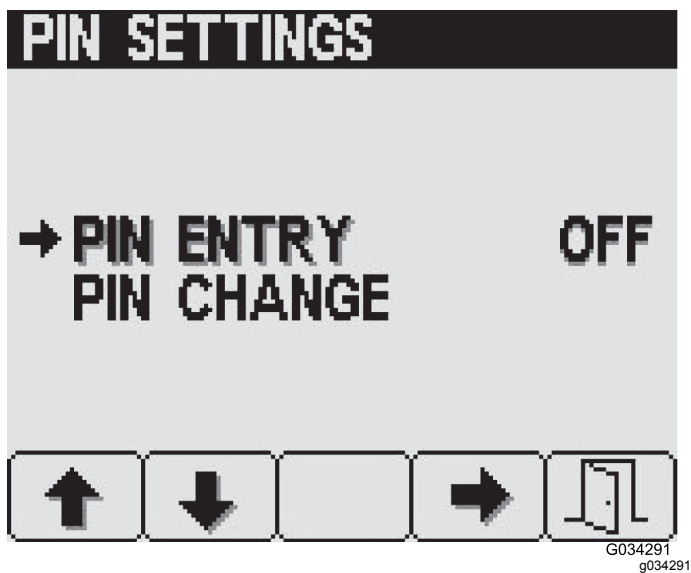

Figure 26

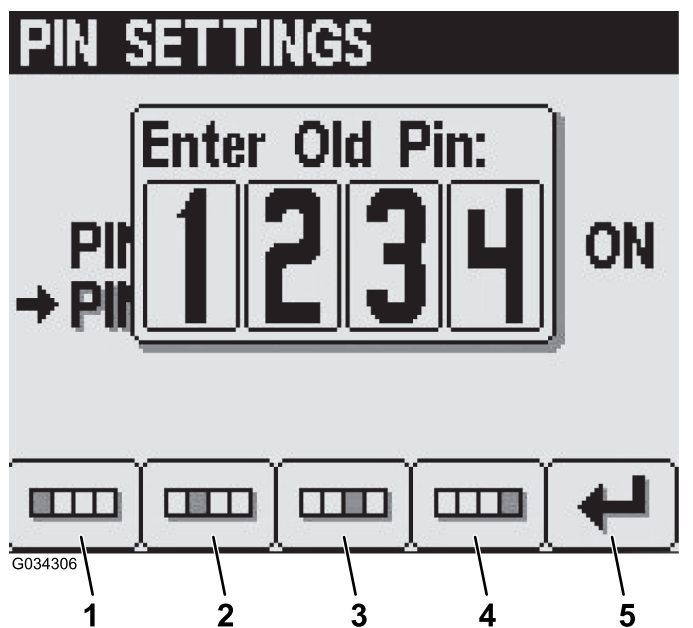

Figure 28

1. Digit 1
2. Digit 2
3. Digit 3
4. Digit 4
5. Enter PIN

Changing the InfoCenter PIN

1. Press button 2 on the Display settings screen until you reach PIN Settings, then press button 4 to select PIN Settings (Figure 24).
2. Enter your PIN using buttons 1 to 4 and press button 5 when you complete the PIN (Figure 25).
3. From the PIN Settings screen, press button 2 until you reach PIN Change, then press button 4 to select PIN Change (Figure 27).

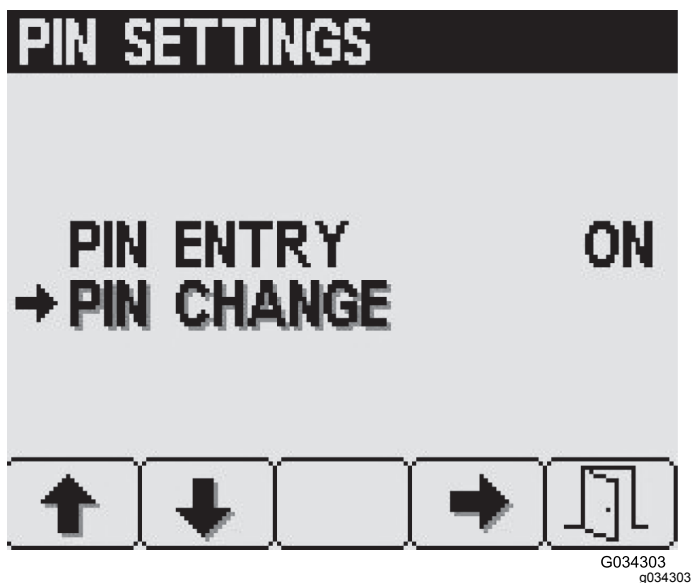

Figure 27

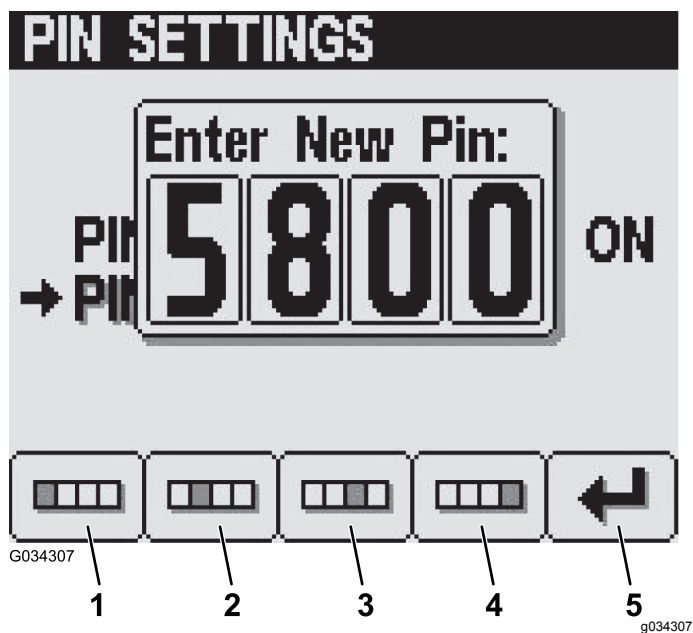

Figure 29

1. Digit 1
2. Digit 2
3. Digit 3
4. Digit 4
5. Enter PIN

4. Enter your old PIN using buttons 1 to 4 and press button 5 when you complete the PIN (Figure 25).

Note: The **default PIN** when you initially create your PIN is **1234**.

6. Confirm your new PIN using buttons 1 to 4 and press button 5 when you complete the PIN (Figure 30).

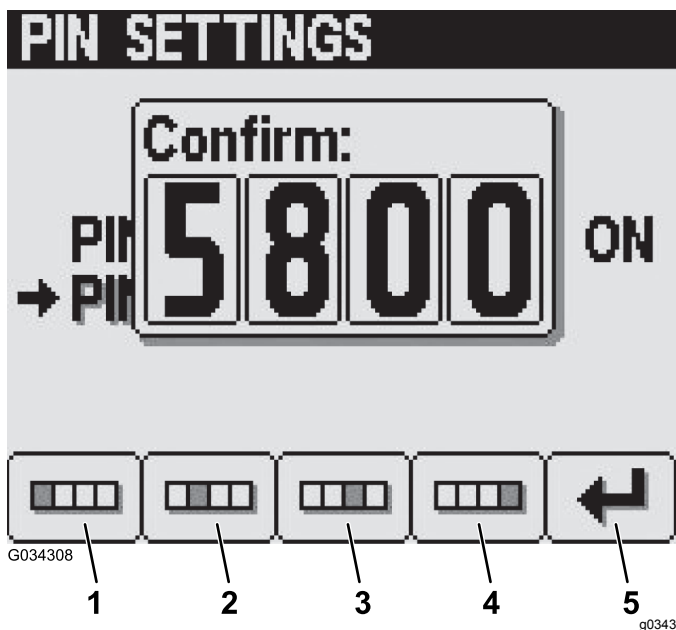

Figure 30

1. Digit 1
2. Digit 2
3. Digit 3
4. Digit 4
5. Enter PIN

Note: After you confirm the pin settings (Figure 30), a Pin Correct screen will appear for approximately 5 seconds.

Boom-Width Settings

The boom-width settings are pre-populated at the manufacturing plant (Figure 19).

Calibration Screen

To access the Calibration screen, press button 2 on the Main Menu screen (Figure 16) until you reach Calibration, and press button 4 to select Calibration.

Note: Pressing button 5 at any time cancels calibrations. If you do so, the machine will automatically use the current calibration rates.

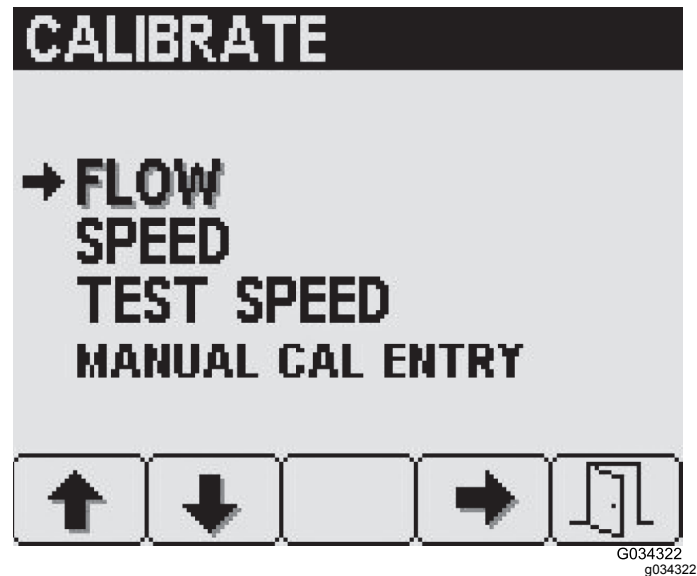

Figure 31

Flow Calibration

Perform the flow calibration before using the machine for the first time, if you change the nozzles, or as needed.

Note: It is recommended to perform a nozzle-uniformity test before starting a Flow Calibration.

1. Set the machine into manual mode, close the boom-sections-bypass valve, turn on the sprayer pump, turn off agitation, and set the engine to full throttle.
2. To access the Flow screen, press button 4 on the Calibrate screen (Figure 31) to select Flow.
3. Fill the sprayer tank with a minimum of 700 L (150 US gallons) of water and apply the parking brake.
4. Press button 2 to move to the next step and to view the Select Nozzle Color screen.
5. Use button 3 and button 4 to select the nozzle that you are using.
6. Press button 2 to move to the next step and to view the To Proceed screen.
7. Press button 2 to move to the next step and to view the 15 Second Catch Test screen.

Note: It is recommended to start the 15 second catch test at 2.75 bar (40 psi), then adjust from there.

All boom sections must be on when performing the catch test.

8. Start at 2.75 bar (40 psi) and use the application-rate switch to adjust the spray pressure so a catch test yields the volume displayed for the selected nozzle color.
9. Press button 2 to move to the next step.
10. Turn on all boom sections, turn on the master boom, and press button 2 to begin calibration.

Note: Calibration takes several minutes.

Note: As the machine sprays, the InfoCenter displays the volume of fluid that it is counting.

Important: Do not turn off the pump or any booms during calibration.

11. If the calibration is successful, a Calibration Successful screen appears; press button 5 to exit.
12. If the calibration is not successful, a Calibration Failed screen appears with the reasoning behind why the calibration failed; press button 5 to exit and restart the calibration.

Speed Calibration

1. Ensure that the tires are properly inflated; refer to [Checking the Tire Pressure \(page 36\)](#).
2. To access the Speed screen, press button 2 on the Calibrate screen until you reach Speed, then press button 4 ([Figure 31](#)) to select Speed.
3. Fill the sprayer tank with a minimum of 700 L (150 US gallons) of water and apply the parking brake.
4. Press button 2 to move to the next step and to view the Speed Calibration screen.
5. Mark off the desired distance before proceeding to the next screen.
6. Press button 2 to move to the next step.
7. Press button 3 to increase the desired distance or press button 4 to decrease the desired distance ([Figure 32](#)).

Note: If you choose to cancel the calibration by pressing button 5, the system automatically defaults to the previously-stored distance.

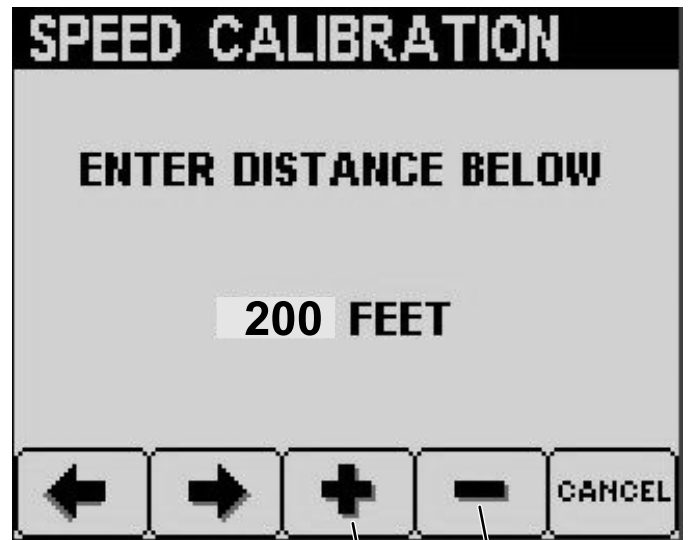

Figure 32

1. Increase the desired distance
2. Decrease the desired distance

8. Ensure that the boom sections are off and press button 2 to begin calibration.

Note: As you drive the machine, and the speed calibration progresses, the InfoCenter displays distance until it reaches the set amount.

Important: Do not shut off the machine after the speed calibration completes.

9. Beginning with the center of the front tire at the "0" mark, drive the vehicle at approximately 5 to 8 kph (3 to 5 mph) to the other mark, and stop with the center of the front tire on the mark.
10. Press button 2 to confirm the distance traveled.
11. If the calibration is successful, a Calibration Successful screen appears; press button 5 to exit.
12. If the calibration is not successful, a Calibration Failed screen appears with the reasoning behind why the calibration failed; press button 5 to exit and restart the calibration.

Manual Calibration Entry

This screen allows you to view and edit the flow calibration number and the speed calibration number.

Service Screen

To access the Service screen, press button 2 on the Main Menu screen (Figure 16) until you reach Service, and press button 4 to select Service.

Note: While spraying, you can view your current flow rate from the Service screen.

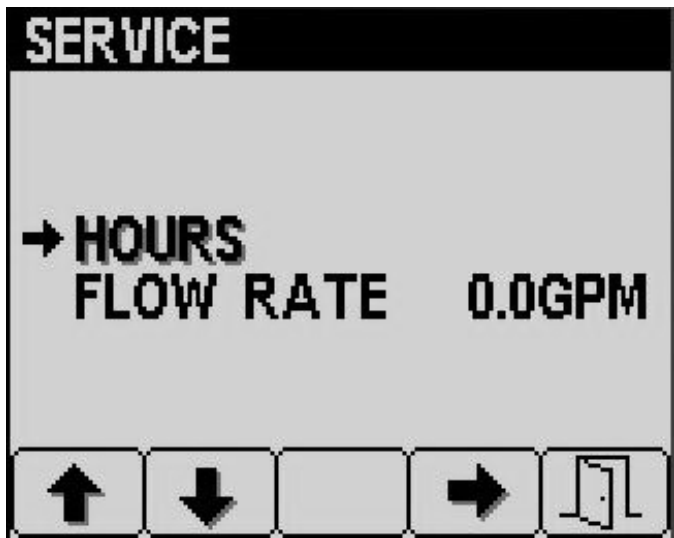

G034305
g034305

Figure 33

From the Service screen, select the Hours screen to view the overall hours of machine, the pump operation hours, and when the next service is due (Figure 34).

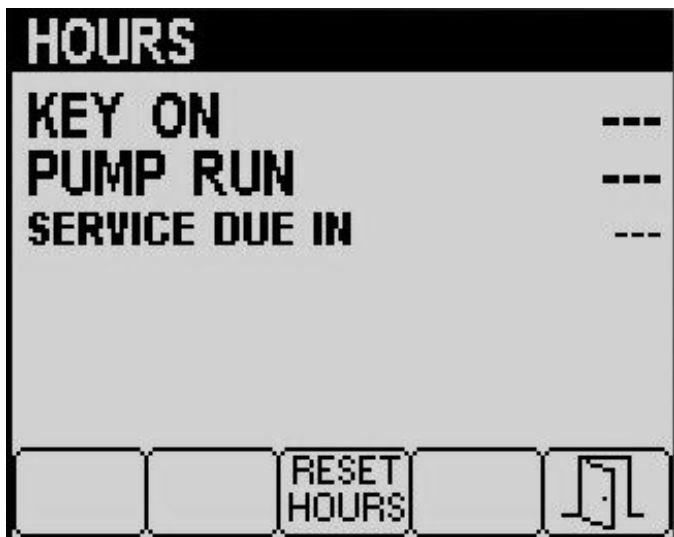

G034304
g034304

Figure 34

To reset the Hours screen, press and hold button 3 (Figure 34).

Diagnostics Screen

To access the Diagnostics screen, press button 2 on the Main Menu screen (Figure 16) until you reach Diagnostics, and press button 4 to select Diagnostics.

Select Input/Output on the Diagnostics screen to view your pumps, booms, and engine input and output (Figure 35).

Select Fault Viewer on the Diagnostics screen to view all faults that have occurred on the machine (Figure 35).

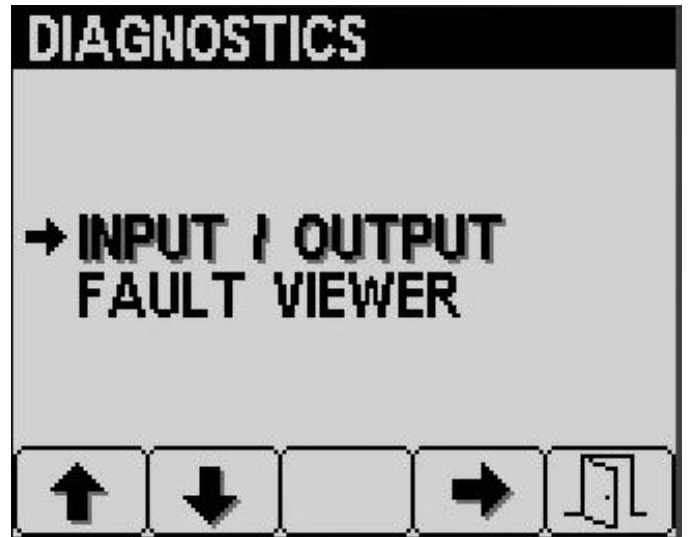

G034283
g034283

Figure 35

About Screen

To access the About screen, press button 2 on the Main Menu screen (Figure 16) until you reach About, and press button 4 to select About (Figure 36).

This screen displays the model number and serial number of your machine.



G034285
g034285

Figure 36

InfoCenter Spray-Area Screens

From the Home screen, press and hold button 5 to open the menu bar and select the Total Area or Sub-Area screen (Figure 37). Use the Total Area screen to track the total number of acres and gallons that you have sprayed across all areas (Figure 37). Use the Sub-Area screen to select the active sub-area and to track the number of acres and gallons that you have sprayed in each sub-area (Figure 38).

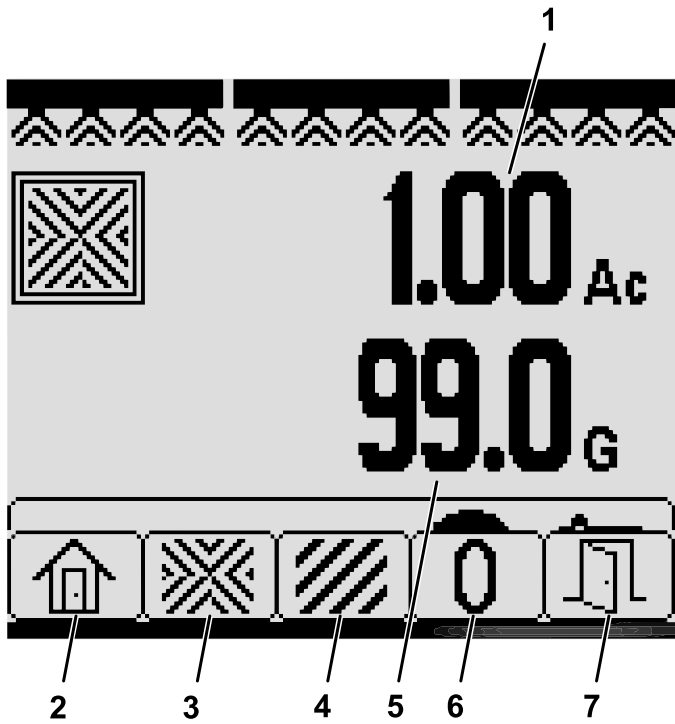

Figure 37
Total Area Screen

- | | |
|-------------------------------|---|
| 1. Total area sprayed (acres) | 5. Total volume sprayed (US gallons) |
| 2. Return to Home screen | 6. Reset total area and volume sprayed. |
| 3. View Total Area screen | 7. Exit |
| 4. View Sub-Area screen | |

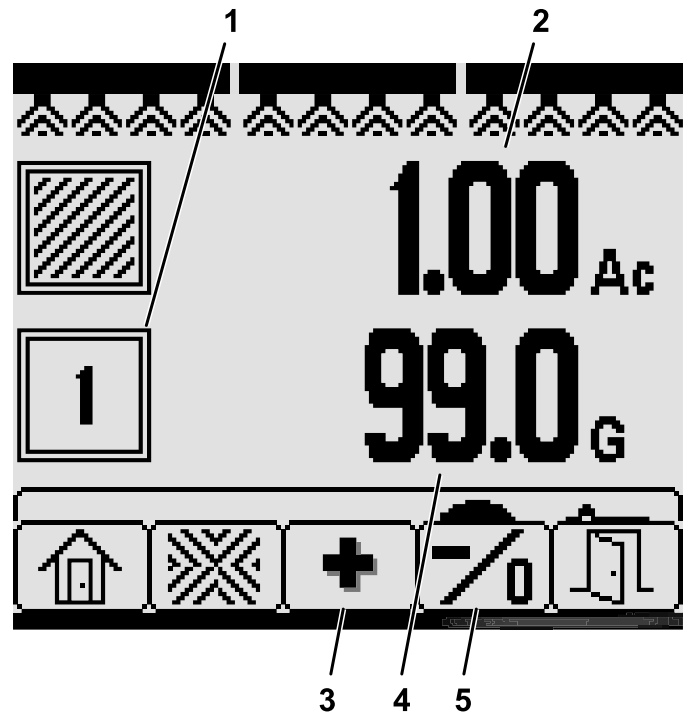

Figure 38
Sub-Area Screen

- | | |
|--|--|
| 1. Active sub-area | 4. Volume sprayed in the active sub-area (US gallons) |
| 2. Area sprayed in the active sub-area (acres) | 5. Select the previous sub-area; hold the button to reset area and volume sprayed for the active sub-area. |
| 3. Select the next sub-area | |

G034279
g034279

G034278
g034278

InfoCenter Advisories

Operator advisories automatically display on the InfoCenter screen when a machine function requires additional action. For example, if you attempt to start the engine while pressing the traction pedal, an advisory displays, indicating that the traction pedal must be in the NEUTRAL position.

For each advisory that occurs, there is a condition (e.g., start prevent, engine stopped), an advisory code (number), a qualifier (the cause of the advisory displayed), and a display text (what the advisory displays as text on the screen) as shown in [Figure 39](#).

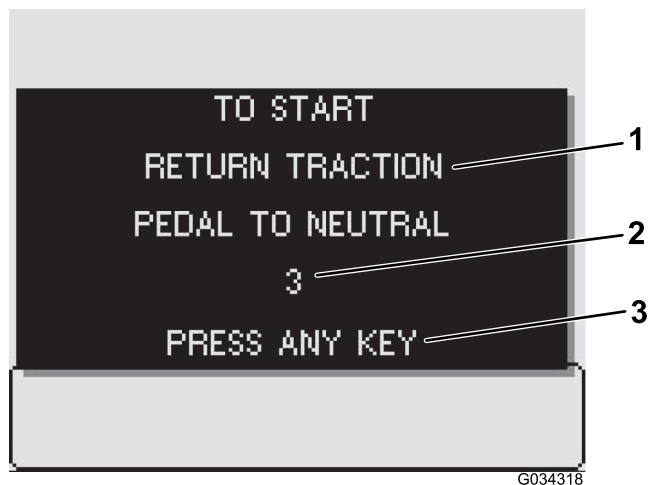

Figure 39

g034318

1. Display text
2. Code
3. Press any key on the InfoCenter to clear the text from the display screen.

Note: Advisories do not log into the fault log.

Note: You can clear an advisory from the display screen by pressing any of the InfoCenter keys.

Refer to the following table for all the InfoCenter advisories:

InfoCenter Advisory Table

Condition	Code	Qualifier	Display Text
Start Prevented	2	Pump switch active	To start, turn pump off
Start Prevented	3	Not in NEUTRAL	To start, return traction pedal to neutral
Start Prevented	4	Out of seat	To start, must be seated or set the parking brake
Start Prevented	5	Starter engage timeout	To start, rest starter
Start Prevented	6	Rinse pump active	To start, turn off rinse pump
Engine Stopped	102	Out of seat	Engine stop due to operator out of seat
Engine Stopped	103	Parking brake set	Engine stop due to parking brake engaged
Pump Start Prevented	202	Boom active	To start pump, turn booms off
Pump Start Prevented	203	Out of seat and parking brake not set	To start pump, must be seated or set parking brake
Pump Start Prevented	205	Engine starting	To start pump, stop cranking engine
Pump Turned Off	206	Out of seat	To start pump, remain seated

InfoCenter Advisory Table (cont'd.)

Condition	Code	Qualifier	Display Text
Tank Status	402	Low spray tank volume	Tank status, volume low
Tank Status	403	Rinse pump active	Tank status, rinse pump on
Parameter Status	502	Wrong parameter value entered	Parameter status, invalid value
Parameter Status	503	A value is outside the range of accepted values	Parameter status, invalid data defaults used
Booms Turned Off	802	Speed dropped	Booms turned off, stopped or moving too slowly

Specifications

Note: Specifications and design are subject to change without notice.

Base weight	1,307 kg (2,882 lb)
Weight with standard spray system, empty, without operator	1,307 kg (2,882 lb)
Weight with standard spray system, full, without operator	2,499 kg (5,510 lb)
Maximum gross vehicle weight (GVW) (on level ground)	3,023 kg (6,665 lb)
Tank capacity	1,135.6 L (300 US gallons)
Overall width with standard spray system booms stored in the X position	226 cm (89 inches)

Overall length with standard spray system	391 cm (154 inches)
Overall length with standard spray system to the top of the booms stored in the X position	442 cm (174 inches)
Overall height with standard spray system	146 cm (57.5 inches)
Overall height with standard spray system to the top of the booms stored in the X position	231 cm (91 inches)
Ground clearance	18.4 cm (7.25 inches)
Wheel base	198 cm (78 inches)

Optional Equipment

The Toro Company has optional equipment and accessories that you can purchase separately and install on your sprayer. Contact your Authorized Service Dealer for a complete list of optional equipment that is currently available for your sprayer.

Operation

Note: Determine the left and right sides of the machine from the normal operating position.

Think Safety First

Please carefully read all of the safety instructions and decals in the safety section. Knowing this information could help you or bystanders avoid injury.

Performing Pre-Starting Checks

Check the following items each time you begin using the sprayer for the day:

- Check the tire pressure.

Note: These tires are different than car tires; they require less pressure to minimize turf compaction and damage.
- Check all fluid levels and add the appropriate amount of specified fluids, if any are found to be low.
- Check the brake pedal operation.
- Check to see that the lights are working.
- With the engine off, check for oil leaks, loose parts, and any other noticeable malfunctions.

If any of the above items are not correct, notify your mechanic or check with your supervisor before taking the sprayer out for the day. Your supervisor may want you to check other items on a daily basis, so ask what your responsibilities are.

Preparing to Drive the Machine

Checking the Engine-Oil Level

Before you start the engine and use the machine, check the oil level in the engine crankcase; refer to [Checking the Engine Oil \(page 56\)](#).

Checking the Cooling System

Before you start the engine and use the machine, check the cooling system; refer to [Checking the Coolant Level \(page 65\)](#).

Checking the Hydraulic System

Before you start the engine and use the machine, check the hydraulic system; refer to [Checking the Hydraulic Fluid \(page 68\)](#).

Checking the Tire Pressure

Service Interval: Before each use or daily

Check the tire pressure to ensure proper levels. Fill the tires to 138 kPa (20 psi).

Note: Also, check the tires for wear or damage.

Checking the Brakes

Service Interval: Before each use or daily

Before starting the sprayer, lightly press the brake pedal. If the pedal travels more than 2.5 cm (1 inch) before you feel resistance, adjust the brakes; refer to [Adjusting the Brakes \(page 67\)](#).

▲ WARNING

If you operate the sprayer with poorly adjusted or worn brakes, you could lose control of the sprayer, resulting in serious injury or death to you or bystanders.

Always check the brakes before operating the sprayer and keep them properly adjusted and repaired.

Adding Fuel

▲ DANGER

In certain conditions, gasoline is extremely flammable and highly explosive. A fire or explosion from gasoline can burn you and others and can damage property.

- Fill the fuel tank outdoors, in an open area, when the engine is cold. Wipe up any gasoline that spills.
- Never fill the fuel tank inside an enclosed trailer.
- Do not fill the fuel tank completely full. Add gasoline to the fuel tank until the level is 6 to 13 mm (1/4 to 1/2 inch) below the bottom of the filler neck. This empty space in the tank allows gasoline to expand.
- Never smoke when handling gasoline, and stay away from an open flame or where gasoline fumes may be ignited by a spark.
- Store gasoline in an approved container and keep it out of the reach of children. Never buy more than a 30-day supply of gasoline.
- Do not operate without entire exhaust system in place and in proper working condition.

▲ DANGER

In certain conditions during fueling, static electricity can be released causing a spark which can ignite the gasoline vapors. A fire or explosion from gasoline can burn you and others and can damage property.

- Always place fuel containers on the ground away from your vehicle before filling.
- Do not fill gasoline containers inside a vehicle or on a truck or trailer bed because interior carpets or plastic truck bed liners may insulate the container and slow the loss of any static charge.
- When practical, remove gas-powered equipment from the truck or trailer and refuel the equipment with its wheels on the ground.
- If this is not possible, then refuel such equipment on a truck or trailer from a portable container, rather than from a fuel dispenser nozzle.
- If a fuel dispenser nozzle must be used, keep the nozzle in contact with the rim of the fuel tank or container opening at all times until fueling is complete.

Recommended Fuel

- For best results, use only clean, fresh (less than 30 days old), unleaded gasoline with an octane rating of 87 or higher ((R+M)/2 rating method).
- **Ethanol:** Gasoline with up to 10% ethanol (gasohol) or 15% MTBE (methyl tertiary butyl ether) by volume is acceptable. Ethanol and MTBE are not the same. Gasoline with 15% ethanol (E15) by volume is not approved for use. Never use gasoline that contains more than 10% ethanol by volume, such as E15 (contains 15% ethanol), E20 (contains 20% ethanol), or E85 (contains up to 85% ethanol). Using unapproved gasoline may cause performance problems and/or engine damage which may not be covered under warranty
- **Do not** use gasoline containing methanol.
- **Do not** store fuel either in the fuel tank or fuel containers over the winter unless a fuel stabilizer is used.
- **Do not** add oil to gasoline.

Filling the Fuel Tank

Fuel tank capacity: approximately 45 L (12 US gallons).

1. Park the machine on a level surface, set the parking brake, stop the pump, stop the engine, remove the key, and allow the engine to cool.
2. Clean the area around the fuel-tank cap (Figure 40).

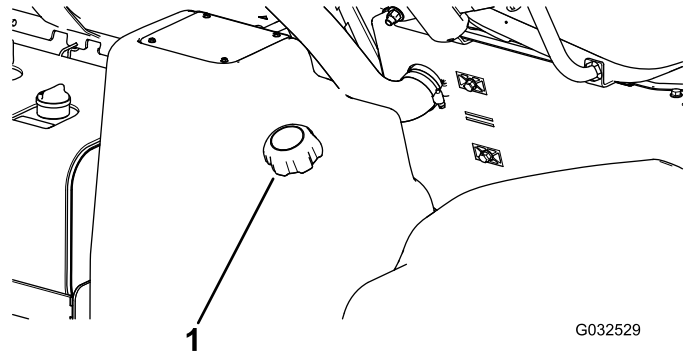

Figure 40

1. Fuel-tank cap

3. Remove the fuel-tank cap.
4. Fill the tank to about 2.5 cm (1 inch) below the top of the tank, (bottom of the filler neck).

Note: This space in the tank allows fuel to expand. **Do not overfill.**

5. Install the fuel-tank cap securely.
6. Wipe up any fuel that may have spilled.

Preparing to Use the Sprayer

Cleaning the Suction Strainer

Service Interval: Before each use or daily Clean the suction strainer more often when using wettable powders.

1. Position the sprayer on a level surface, set the parking brake, stop the pump, stop the engine, and remove the key from the starter switch.
2. At the top of the sprayer tank, remove the retainer that secures the hose fitting attached to the large hose and the strainer housing (Figure 41).

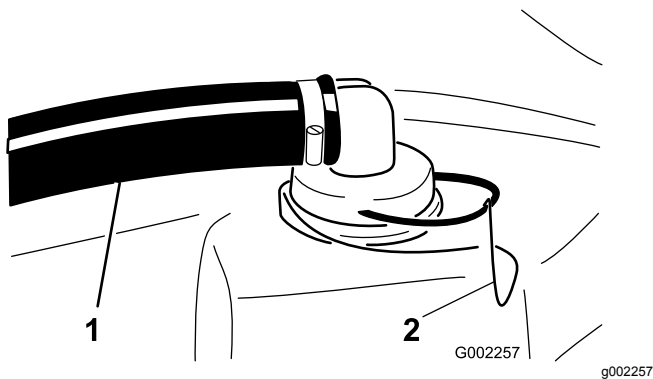

Figure 41

1. Suction hose
2. Retainer

3. Remove the hose and hose fitting from the strainer housing (Figure 41).
4. Pull the suction strainer out of the strainer housing in the tank (Figure 42).

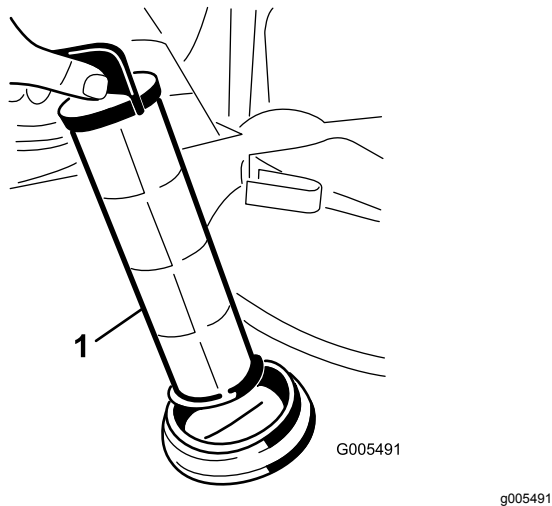

Figure 42

1. Suction strainer

5. Clean the suction strainer with clean water.
6. Insert the suction strainer into the strainer housing until the strainer is fully seated.
7. Align the hose and hose fitting to the strainer housing at the top of the tank to the and secure fitting and housing with the retainer that you removed in step 2.

Inspecting the Tank Straps

Service Interval: Before each use or daily—Check the tank straps.

Important: Over tightening the tank-strap fasteners can result in deforming and damaging the tank and straps.

1. Fill the main tank with water.
2. Check to see if there is any movement between the tank straps and the tank (Figure 43).

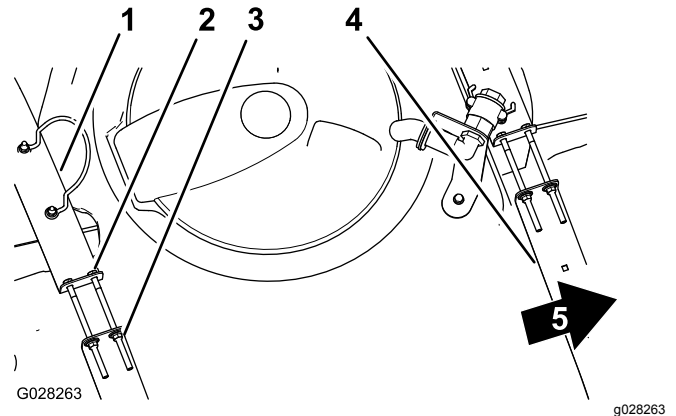

Figure 43

1. Rear tank strap
2. Bolt
3. Flanged locknut
4. Forward tank strap
5. Front of the machine

3. If the tank straps fit loosely to the tank, tighten the flanged locknuts and bolts at the top of straps until the straps are flush with the surface of the tank (Figure 43).

Note: Do not over tighten the tank-strap hardware.

Operating the Machine

Starting the Engine

1. Sit on the operator's seat and keep your foot off the traction pedal.
2. Ensure that the parking brake is engaged, the traction pedal is in the NEUTRAL position, and the throttle is in the SLOW position.
3. Turn the switch to the ON/PREHEAT position.

Note: An automatic timer controls the preheat for approximately 6 seconds.
4. After preheating, turn the key to the START position.
5. Crank the engine for no longer than 15 seconds.
6. Release the key when the engine starts.

7. If the engine requires additional preheating, turn the key to the OFF position, then to the ON/PREHEAT position.

Note: Repeat steps 3 through 7 as required.

8. Run the engine at IDLE speed or partial throttle until the engine warms up.

Driving the Machine

1. Release the parking brake and press the traction pedal forward to drive the machine forward or press the pedal rearward to drive the machine in reverse.

Important: Ensure that you allow the sprayer to come to a stop before switching between the FORWARD and REVERSE positions.

2. To slowly stop the machine, release the traction pedal.

Note: The traction pedal returns to the NEUTRAL position.

3. To stop quickly, press the brake pedal.

Note: The stopping distance of the machine may vary depending on the sprayer-tank load and ground speed of the machine.

Setting the Ground-Speed-Lock Switch

⚠ CAUTION

If you press the ground-speed-lock switch and do not have your foot on the traction pedal, the traction unit may suddenly stop and cause you to lose control, possibly injuring you or bystanders.

Ensure that you have your foot on the traction pedal when you disengage the ground-speed-lock switch.

1. Drive forward and attain the desired ground speed; refer to [Driving the Machine \(page 39\)](#).
2. Press the top of the ground-speed-lock switch.

Note: The light on the switch illuminates.

3. Take your foot off the traction pedal.

Note: The sprayer maintains the speed that you set.

4. To release the ground-speed-lock switch, either place your foot on the traction pedal and press the bottom of the switch or remove your foot from the traction pedal and press the brake pedal.

Note: The light on the switch turns off and the traction control returns to the traction pedal.

Stopping the Engine

1. Move all the controls to the NEUTRAL position.
2. Press the brake to stop the sprayer.
3. Set the parking brake.
4. Move the throttle lever to the IDLE/SLOW position.
5. Turn the starter key to the OFF position.
6. Remove the key from the switch to prevent someone from accidentally starting the engine.

Breaking in a New Sprayer

To provide proper performance and long sprayer life, follow these guidelines for the first 100 operating hours:

- Check the fluid and engine-oil levels regularly and be alert for indications of overheating in any component of the sprayer.
- After filling the tank, check the tank straps for any play. Tighten as necessary.
- After starting a cold engine, let it warm up for about 15 seconds before accelerating.
- Avoid hard-braking situations for the first several hours of new sprayer break-in operation. New brake linings may not be at optimum performance until several hours of use has caused the brakes to become burnished (broken-in).
- Avoid racing the engine.
- Refer to the [Maintenance \(page 48\)](#) section for any special, low-hour checks.

Operating the Sprayer

To operate the Multi Pro® Sprayer, first fill the spray tank, apply the solution to the work area, and finally clean the tank and spray system. It is important that you complete all 3 of these steps in succession to avoid damaging the sprayer. For example, do not mix and add chemicals in the spray tank at night and then spray in the morning. This leads to separation of the chemicals and possible damage to the sprayer components.

⚠ CAUTION

Chemicals are hazardous and can cause personal injury.

- Read the directions on the chemical labels before handling the chemicals and follow all manufacturer recommendations and precautions.
- Keep chemicals away from your skin. Should contact occur, wash the affected area thoroughly with soap and clean water.
- Wear goggles and any other protective equipment recommended by the chemical manufacturer.

The Multi Pro® Sprayer has been specifically designed to have high durability in order to provide the long sprayer life you need. Different materials have been chosen for specific reasons at different locations on your sprayer to meet this goal. Unfortunately, there is no single material which is perfect for all foreseeable applications.

Some chemicals are more aggressive than others and each chemical interacts differently with various materials. Some consistencies (e.g., wettable powders, charcoal) are more abrasive and lead to higher wear rates. If a chemical is available in a formulation that would provide increased life to the sprayer, use this alternative formulation.

As always, remember to clean your sprayer and spray system thoroughly after all applications. This will ensure that your sprayer has a long and trouble-free life.

Note: If you have questions or need additional information regarding the spray-control system, refer to the *Operator's Manual* supplied with the system.

Filling the Fresh-Water Tank

Always fill the fresh-water tank with clean water before handling or mixing any chemicals.

The fresh-water tank is located on the ROPS, behind the passenger seat (Figure 44).

Note: It supplies a source of fresh water for you to wash chemicals off your skin, eyes, or other surfaces in the case of accidental exposure.

To fill the tank, unscrew the cap on the top of the tank, fill the tank with fresh water, and tighten the cap.

To open the fresh-water tank spigot, turn the lever on the spigot.

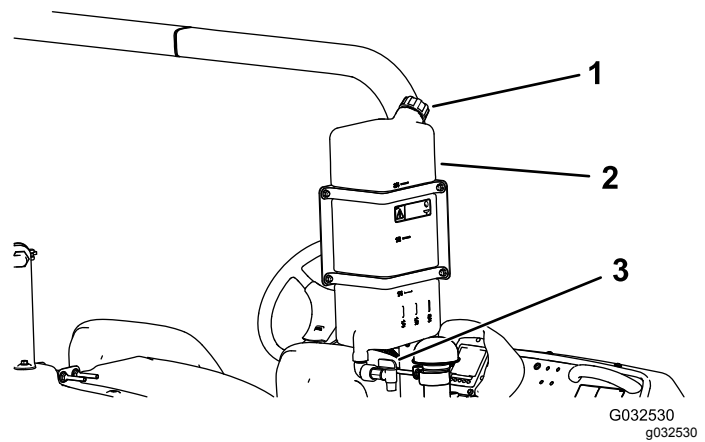

Figure 44

1. Filler cap
2. Fresh-water tank
3. Spigot

Filling the Spray Tank

Important: Ensure that the chemicals you use are compatible with Viton (see the manufacturer's label; it should indicate if it is not compatible). Using a chemical that is not compatible with Viton will degrade the O-rings in the sprayer, causing leaks.

Important: The tank-volume markings are for reference only and cannot be considered accurate for calibration.

Important: After filling the tank for the first time, check the tank straps for any play. Tighten as necessary.

1. Stop the sprayer on a level surface, stop the engine, and set the parking brake.
2. Determine the amount of water needed to mix the amount of chemical you need as prescribed by the chemical manufacturer.
3. Open the tank cover on the spray tank.

Note: The tank cover is located in the center of the top of the tank. To open it, turn the front half of the cover counterclockwise and swing it open. You can remove the strainer inside for cleaning. To seal the tank, close the cover and rotate the front half clockwise.

4. Add 3/4 of the required water to the spray tank using the anti-siphon fill receptacle.

Important: Always use fresh, clean water in the spray tank. Do not pour concentrate into an empty tank.

5. Start the engine, set the parking brake, set the pump switch to the ON position, and move the throttle lever to HIGH IDLE.

6. Set the agitation switch to the ON position.
Important: Prior to introducing wettable powders into any Toro Spray System mix the powders in a suitable container with sufficient fresh water to create a free flowing slurry. Failure to do so may result in chemical deposits on the bottom of the tank, degraded agitation, clogging of filters, and improper agitation rates.
Toro recommends using the approved Eductor Kit for this machine. Contact your Authorized Toro Dealer for more information.
7. Add the proper amount of chemical concentrate to the tank, as directed by the chemical manufacturer.
8. Add the remaining water to the tank.

Operating the Booms

The boom-lift switches on the sprayer control panel allows you to move the booms between transport position and spray position without leaving the operator's seat. It is recommended to change boom positions while the machine is not moving.

1. Stop the sprayer on level ground.
2. Use the boom-lift switches to lower the booms.

Note: Wait until the booms reach the fully-extended spray position.

3. When you need to retract the booms, stop the sprayer on level ground.
4. Use the boom-lift switches to raise the booms.

Note: Raise the booms until they have moved completely into boom transport cradle, forming the "X" transport position and the boom cylinders are fully retracted.

Important: To prevent damage to the boom-actuator cylinder, ensure that the actuators are fully retracted before transport.

Important: Release the actuator switch once the booms have reached the desired position. Running the actuators against the stops may damage the cylinders and/or other hydraulic components.

Operating the Boom-Transport Cradle

The sprayer is equipped with a boom-transport cradle that has a unique safety feature. In the event of accidental boom contact with a low overhead object while in the transport position, the boom(s) can be pushed out of the transport cradles. If this occurs, the booms will come to rest in a near-horizontal position

to the rear of the vehicle. While the booms will not be damaged due to this movement, they should be immediately put back into the transport cradle.

Important: The booms can be damaged by transporting them in any position other than the "X" transport position using the boom transport cradle.

To put the booms back into the transport cradle, lower the boom(s) to the spray position, and then raise the boom(s) back into the transport position. Ensure that the boom cylinders are fully retracted to prevent actuator rod damage during storage.

Applying Spray Manual-Spray Operation

Important: To ensure that your solution remains well mixed, use the agitation feature whenever you have solution in the tank. For agitation to work, the pump must be on, and the engine must be running above the IDLE position.

Note: This procedure assumes that the pump is on; refer to [Filling the Spray Tank \(page 40\)](#).

1. Set the master-boom switch to the OFF position.
2. Adjust the throttle to the desired position to spray.
3. Drive to the spraying location.
4. Lower the booms into position.
5. Set the individual section switches, as needed, to the ON position.
6. Use the application-rate switch to achieve the desired spray pressure as indicated in the nozzle-selection guide provided with the sprayer.
7. Drive at the desired speed and then set the master-boom switch to the ON position to begin spraying.

Note: When the tank is nearly empty, the agitation may cause foaming in the tank. In this case, turn the agitation switch to the OFF position. Alternatively, you can use an anti-foaming agent in the tank.

8. When finished spraying, set the master-boom switch to the OFF position to turn off all booms, then set the pump switch to the OFF position.

Note: Return the booms to the transport position and drive the sprayer to the cleaning area.

Important: Always raise the booms until they have moved completely into boom-transport cradle forming the "X" transport position and the boom cylinders

are fully retracted whenever you move the sprayer from one spraying area to another, or move to a storage or cleaning area.

Taking Proper Turf Care Precautions while Operating in Stationary Modes

Important: Under some conditions, heat from the engine, radiator, and muffler can damage grass when operating the sprayer in a stationary mode. Stationary modes include tank agitation, hand spraying with a spray gun, or using a walking boom.

Use the following precautions:

- **Avoid** stationary spraying when conditions are very hot and/or dry, as turf can be more stressed during these periods.
- **Avoid** parking on the turf while stationary spraying. Park on a cart path whenever possible.
- **Minimize** the amount of time the machine is left running over any particular area of turf. Both time and temperature affect how much the grass may be damaged.
- **Set the engine speed as low as possible** to achieve the desired pressure and flow. This will minimize the heat generated and the air velocity from the cooling fan.
- **Allow heat to escape** upward from the engine compartment by raising the seat assemblies during stationary operation rather than being forced out under the vehicle.

Spraying Tips

- Do not overlap areas that you have previously sprayed.
- Watch for plugged nozzles. Replace all worn or damaged nozzles.
- Use the master-boom switch to stop the spray flow before stopping the sprayer. Once stopped, use the engine-throttle control to hold the engine speed up to keep the agitation running.
- You will obtain better results if the sprayer is moving when you turn the booms on.

Unclogging a Nozzle

If a nozzle becomes clogged while you are spraying, you can clean it using a hand-spray bottle of water or a toothbrush.

1. Stop the sprayer on a level surface, stop the engine, and set the parking brake.
2. Set the master-boom switch to the OFF position and then set the pump switch to the OFF position.
3. Remove the clogged nozzle and clean it using a spray bottle of water or a toothbrush.

Selecting a Nozzle

Note: Refer to the nozzle-selection guide that is available through your Authorized Toro Dealer.

The turret bodies can accept up to 3 different nozzles. To select the desired nozzle perform the following:

1. Stop the sprayer on a level surface, stop the engine, and set the parking brake.
2. Set the master-boom switch to the OFF position and set the pump switch to the OFF position.
3. Rotate the turret of the nozzles in either direction to the correct nozzle.

Cleaning the Sprayer

Important: You must always empty and clean the sprayer immediately after each use. Failure to do so may cause the chemicals to dry or thicken in the lines, clogging the pump and other components.

Toro recommends using the approved Clean Rinse Kit for this machine. Contact your Authorized Toro Dealer for more information.

Clean the spray system after **each** spraying session. To properly clean the spray system:

- Use 3 separate rinses.
 - Use the cleaners and neutralizers as recommended by the chemical manufacturers.
 - Use pure, clean water (no cleaners or neutralizers) for the **last** rinse.
1. Stop the sprayer, set the parking brake, and turn off the engine.
 2. Locate the tank-drain valve on the rear of the machine ([Figure 45](#)).

Note: The drain valve is to the rear of pump, attached to the support bracket.

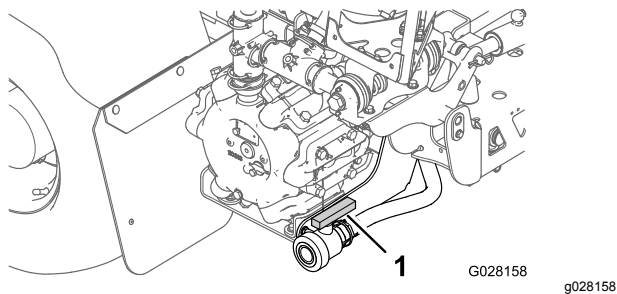

Figure 45

1. Tank-drain handle

Open the valve to drain any unused material from the tank and dispose of it according to local codes and the material manufacturer's instructions (Figure 46). After draining, remove the lynch pin on the bracket securing the drain valve to the machine and let the valve rest on the ground. This allows any residual material in the line to drain.

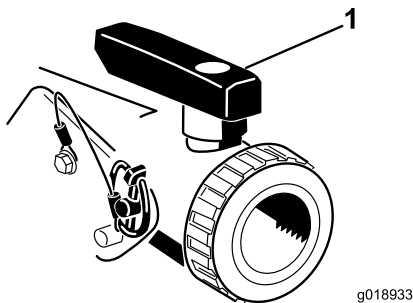
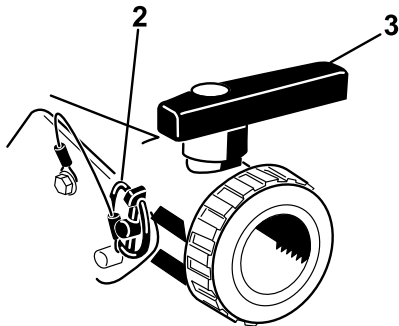

Figure 46

1. Valve open
2. Lynch pin
3. Valve closed

3. When the tank has drained completely, install the valve to frame with the lynch pin removed previously and close the drain valve (Figure 46).
4. Fill the tank with at least 190 L (50 US gallons) of clean, fresh water and close the cover.

Note: You can use a cleaning/neutralizing agent in the water as needed. On the final rinse, use only clean, clear water.

5. Lower the booms into the spray position.
6. Start the engine and move the throttle lever to a higher idle.
7. Ensure that the agitation switch is in the ON position.
8. Set the pump switch to the ON position and use the application-rate switch to increase the pressure to a high setting.
9. Set the master-boom switch and boom-control switches to the ON positions to begin spraying.
10. Allow all of the water in the tank to spray out through the nozzles.
11. Check the nozzles to ensure that they are all spraying correctly.
12. Set the master-boom switch to the OFF position, set the pump switch to the OFF position, and stop the engine.
13. Repeat steps 4 through 12 at least 2 more times to ensure that the spray system is fully cleaned.

Important: You must always complete this procedure at least 3 times to ensure that the spray system is fully clean, preventing damage to the system.

14. Clean the strainer; refer to [Cleaning the Suction Strainer](#) (page 37).

Important: If you used wettable powder chemicals, clean the strainer after each tank.

15. Using a garden hose, rinse off the outside of the sprayer with clean water.
16. Remove the nozzles and clean them by hand.

Note: Replace damaged or worn nozzles.

Setting the Boom-Section-Bypass Valves

Manual Mode Only

Important: When operating in Auto mode, the boom-sections-bypass shutoff valve must be closed.

Before using the sprayer for the first time, if you change the nozzles, or as needed, calibrate the sprayer flow, speed, and set the boom-section bypass (if operating in Manual mode); refer to [Calibration Screen \(page 29\)](#).

Note: The section valves must be calibrated each time the nozzles are changed (only if operating/spraying in Manual mode).

Select an open flat area to perform this procedure.

1. Fill the spray tank halfway with clean water.
2. Lower the sprayer booms.
3. Set the parking brake.
4. Set the spray control switch to manual.
5. Set the 3 boom switches to the ON position, but leave the master-boom switch off.
6. Set the pump switch to the ON position, and turn on the agitation.
7. On the InfoCenter, navigate to the Calibration screen and select Test Speed ([Figure 31](#)).
8. Using the plus (+) and minus (-) symbols, enter a test speed of 5.6 km/h (3.5 mph) and set the test speed setting to the ON position.
9. Press button 5 to return to the home screen.
10. Using the application-rate switch, adjust the application rate according to the table below.

Nozzle Application Rate Table

Nozzle Color	SI (Metric)	English	Turf
Yellow	159 L/ha	17 gpa	0.39 gpk
Red	319 L/ha	34 gpa	0.78 gpk
Brown	394 L/ha	42 gpa	0.96 gpk
Gray	478 L/ha	51 gpa	1.17 gpk
White	637 L/ha	68 gpa	1.56 gpk
Blue	796 L/ha	85 gpa	1.95 gpk
Green	1,190 L/ha	127 gpa	2.91 gpk

11. Turn off the left boom and adjust the boom-bypass knob ([Figure 47](#)) until the rate displayed is at the previous level according to the table.

Note: The numbered indicators on the bypass knob and needle are for reference only.

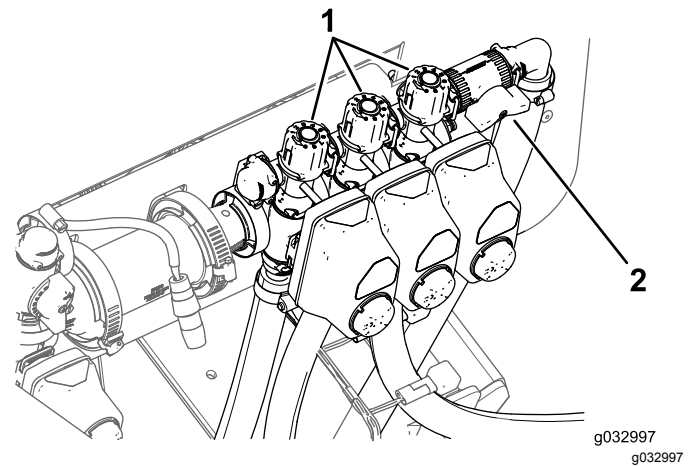

Figure 47

1. Boom-section-bypass adjustment knobs
2. Boom-sections-bypass shutoff valve

12. Turn on the left boom and turn off the right boom.
13. Adjust the right boom-bypass knob ([Figure 47](#)) until the rate displayed is at the previous level according to the table.
14. Turn on the right boom and turn off the center boom.
15. Adjust the center boom-bypass knob ([Figure 47](#)) until the rate displayed is at the previous level according to the table.
16. Turn all the booms off.
17. Turn the pump off.

Positioning the Agitation-Bypass-Valve Knob

- The agitation-bypass valve is in the full OPEN position as shown in A of [Figure 48](#).
- The agitation-bypass valve is in the CLOSED (0) position as shown in B of [Figure 48](#).
- The agitation-bypass valve is in an INTERMEDIATE (ADJUSTED RELATIVE TO THE PRESSURE GAUGE FOR THE SPRAYER SYSTEM) position as shown in C of [Figure 48](#).

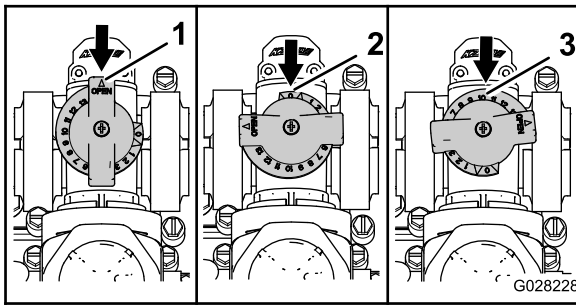

Figure 48

1. Open
2. Closed (0)
3. Intermediate position

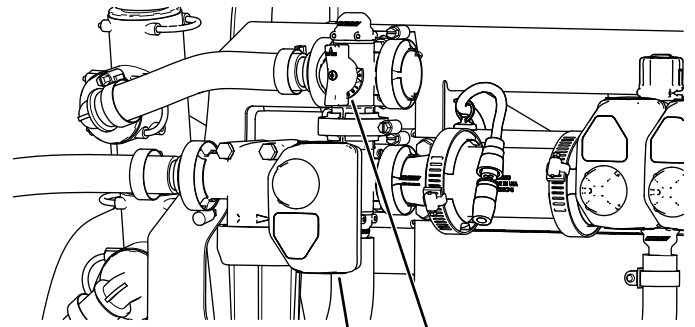

Figure 49

1. Actuator (agitation valve)
2. Agitation-bypass valve

Calibrating the Agitation-Bypass Valve

Service Interval: Yearly—Calibrate the agitation-bypass valve.

Important: If you have the ExcelaRate™ Spray System installed turn the selection switch to **MANUAL** mode.

1. Select an open, flat area to perform this procedure.
2. Fill the spray tank half full with clean water.
3. Verify that the agitation-control valve is open.
 - Note:** If it has been adjusted, open it completely at this time.
4. Set the parking brake and start the engine.
5. Set the pump switch and the agitation switch to the ON position.
6. Turn the master-boom switch to the OFF position.
7. Move the throttle lever to the FAST position.
8. Use the application-rate switch to adjust the sprayer-system pressure to 689 kPa (100 psi).
9. Turn the agitation switch to the OFF position and read the pressure gauge.
 - If the pressure gauge indicates 689 kPa (100 psi), the agitation-bypass valve is properly calibrated.
 - If the pressure gauge indicates differently, continue to the next step.
10. Adjust the agitation-bypass valve (Figure 49) on the backside of the agitation valve until the sprayer system pressure indicated on the gauge indicates 689 kPa (100 psi).

11. Turn the pump switch to the OFF position.
12. Move the throttle lever to the IDLE/SLOW position and turn the key switch to the OFF position.

Locating the Pump

The pump is located near the back of the tank on the left side (Figure 50).

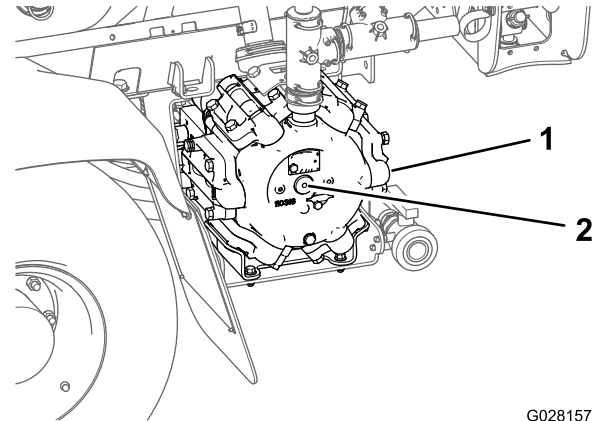

Figure 50

1. Pump
2. Grease fitting

Transporting the Sprayer

For moving the sprayer long distances, use a trailer. Secure the sprayer to the trailer. Also, ensure that the booms are tied down and secure. [Figure 51](#) and [Figure 52](#) illustrate the tie-down points.

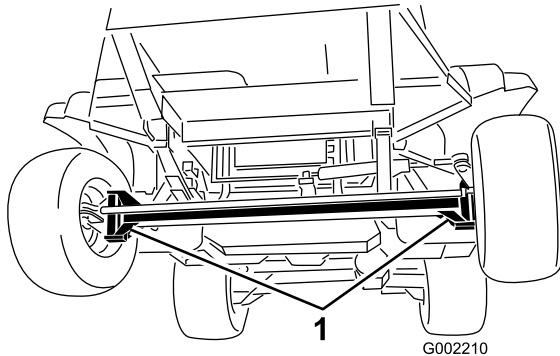

Figure 51

g002210

1. Tie-down points

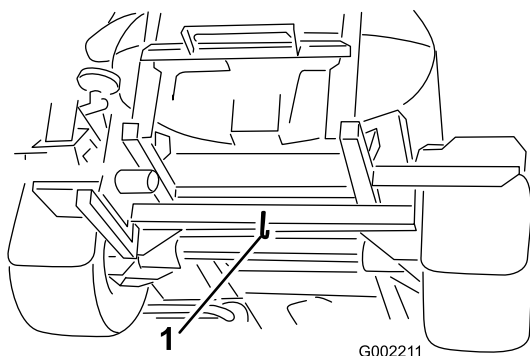

Figure 52

g002211

1. Rear tie-down point

Towing the Sprayer

In case of an emergency, the sprayer can be towed for a short distance after you open the tow valve. However, we do not recommend this as a standard procedure.

⚠ WARNING

Towing at excessive speeds could cause a loss of steering control, resulting in personal injury.

Never tow the sprayer at faster than 4.8 kph (3 mph).

Towing the sprayer is a 2-person job. If the machine must be moved a considerable distance, transport it on a truck or trailer; refer to [Transporting the Sprayer](#) (page 46).

1. Rotate the tow valve ([Figure 53](#)) 90° in either direction to open the tow valve.

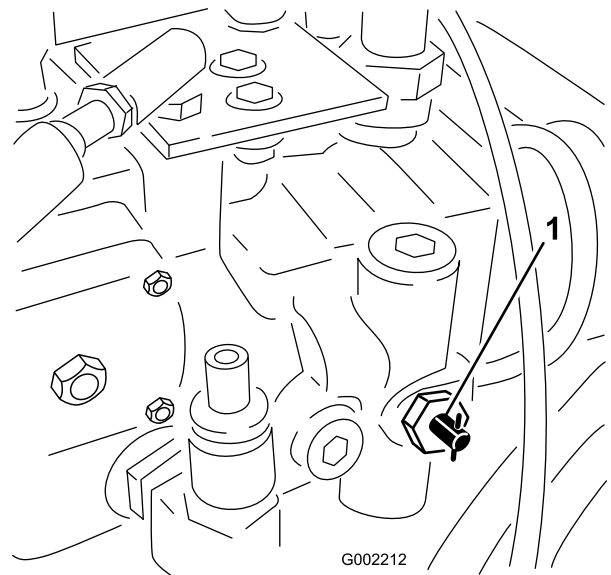

Figure 53

g002212

1. Tow valve

***Important:* If you do not open the tow valve before towing the sprayer, you will damage the transmission.**

2. Affix a tow line to the frame; refer to the front and rear towing points ([Figure 54](#) and [Figure 55](#)).

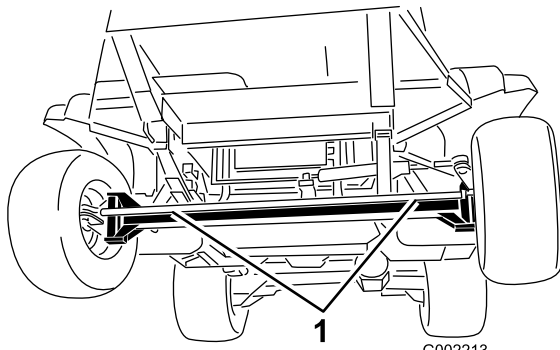

G002213

g002213

Figure 54

1. Front towing points
-

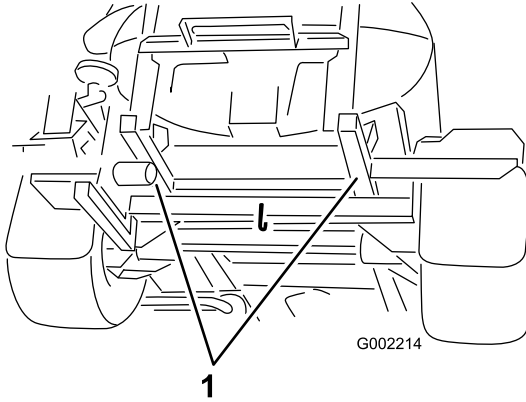

G002214

g002214

Figure 55

1. Rear towing points
-

3. Release the parking brake.
4. Tow the sprayer at less than 4.8 kph (3 mph).
5. When finished, close the tow valve and torque it to 7 to 11 N·m (5 to 8 ft-lb).

Maintenance

Recommended Maintenance Schedule(s)

Maintenance Service Interval	Maintenance Procedure
After the first 5 hours	<ul style="list-style-type: none"> • Replace the hydraulic-fluid filters.
After the first 8 hours	<ul style="list-style-type: none"> • Torque the wheel-lug nuts. • Change the rear planetary-gearbox fluid. • Check the fan/alternator belt.
After the first 50 hours	<ul style="list-style-type: none"> • Change the engine oil and oil filter. • Check the fuel lines and connections.
After the first 200 hours	<ul style="list-style-type: none"> • Pack the front wheel bearings.
Before each use or daily	<ul style="list-style-type: none"> • Check the tire pressure. • Check the brakes. • Clean the suction strainer. • Check the tank straps. • Check the air cleaner. • Check the engine oil. • Check the coolant level. • Check the hydraulic-fluid level.
Every 50 hours	<ul style="list-style-type: none"> • Lubricate the pump. • Lubricate all grease fittings. • Check the battery-cable connections.
Every 100 hours	<ul style="list-style-type: none"> • Lubricate the boom hinges. • Replace the air-filter element. • Torque the wheel-lug nuts. • Inspect the condition and wear of the tires. • Check the cooling-system hoses for wear and damage. • Check the fan/alternator belt.
Every 200 hours	<ul style="list-style-type: none"> • Change the engine oil (including synthetic oil) and oil filter. • Check front wheel toe-in. • Inspect all hoses and connections for damage and proper attachment. • Clean the radiator fins.
Every 400 hours	<ul style="list-style-type: none"> • Grease the actuator-rod bearings. • Complete all yearly maintenance procedures specified in the engine operator's manual. • Check the fuel lines and connections. • Service the fuel filter. • Drain and clean the fuel tank. • Pack the front wheel bearings. • Change the planetary-gearbox fluid. • Check the coolant (as directed by the manufacturer) and change if necessary. • Replace the hydraulic-fluid filters. • Change the hydraulic fluid. • Inspect the O-rings in the valve assemblies. • Change the pressure filter. • Inspect the pump diaphragm and replace if necessary. • Inspect the pump check valves and replace if necessary. • Inspect the pivot bushings.
Every 1,000 hours	<ul style="list-style-type: none"> • Check the PCV valve.
Yearly	<ul style="list-style-type: none"> • Flush the sprayer with clean water. • Calibrate the agitation-bypass valve.

Download a free copy of the electrical or hydraulic schematic by visiting www.Toro.com and searching for your machine from the Manuals link on the home page.

Daily Maintenance Checklist

Duplicate this page for routine use.

Maintenance Check Item	For the week of:						
	Monday	Tuesday	Wednesday	Thursday	Friday	Saturday	Sunday
Check the brake and parking-brake operation.							
Check the neutral-lockout-switch operation.							
Check the fuel level.							
Check the engine-oil level.							
Check the hydraulic-fluid level.							
Check the coolant level.							
Inspect the air filter.							
Inspect the radiator and oil cooler for debris.							
Check for any unusual engine noises.							
Check for any unusual operating noises.							
Check the tire pressure.							
Check for fluid leaks.							
Check all hydraulic and fluid hoses for damage, kinks, or wear.							
Check the instrument operation.							
Check the accelerator operation.							
Clean the suction strainer.							
Lubricate all grease fittings ¹							
Touch up any damaged paint.							

¹Immediately after **every** washing, regardless of the interval listed

Notation for Areas of Concern

Inspection performed by:		
Item	Date	Information
1		
2		
3		
4		
5		
6		
7		
8		
9		
10		

⚠ CAUTION

If you leave the key in the starter switch, someone could accidentally start the engine and seriously injure you or other bystanders.

Remove the key from the starter switch before you do any maintenance.

Pre-Maintenance Procedures

Jacking the Sprayer Up

Whenever running the engine for routine maintenance and/or engine diagnostics, the rear wheels of the sprayer should be 25 mm (1 inch) off the ground with the rear axle supported on jack stands.

⚠ DANGER

A sprayer on a jack may be unstable and slip off of the jack, injuring anyone beneath it.

- Always remove the key from the starter switch before getting off the sprayer.
- Block the tires when the sprayer is on a jack.
- Support the machine with jack stands.

The jacking point at the front of the sprayer is under the front axle, directly under the leaf springs (Figure 56).

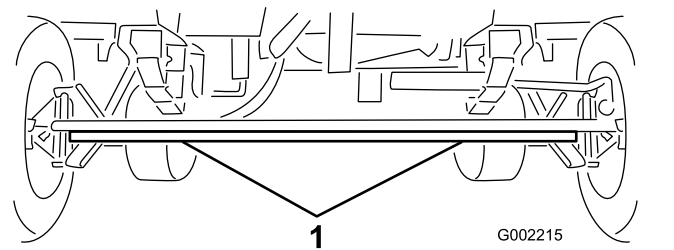

Figure 56

1. Front jacking points

The jacking point at the rear of the sprayer is on the rear side where the boom supports are (Figure 57).

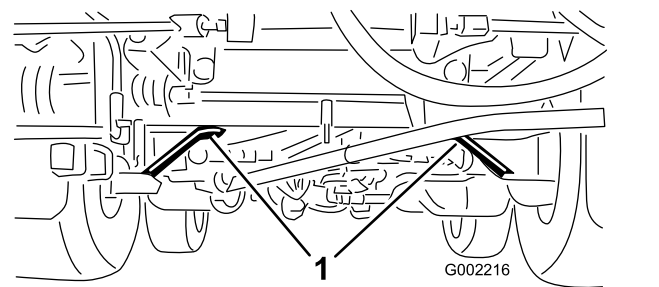

Figure 57

1. Rear jacking points

Accessing the Engine

Removing the Forward Heat Shield

1. Set the parking brake, stop the pump, stop the engine, and remove the key from the starter switch.
2. Raise the front and back of the machine and support it with jack stands; refer to [Jacking the Sprayer Up](#) (page 50).
3. Remove the 6 hex-head bolts and 6 washers that secure the front, forward heat shield to the chassis and remove the shield ([Figure 58](#)).

Note: Retain the bolts, washers, and heat shield for installation in [Installing the Engine-Heat Shield](#) (page 51).

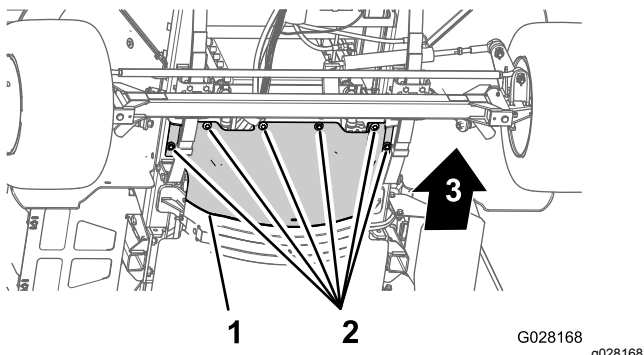

Figure 58

1. Forward heat shield
2. Hex-head bolts and washers

Installing the Engine-Heat Shield

1. Align the rear flange of the forward heat shield over the forward flange of the rear heat shield ([Figure 59](#)).

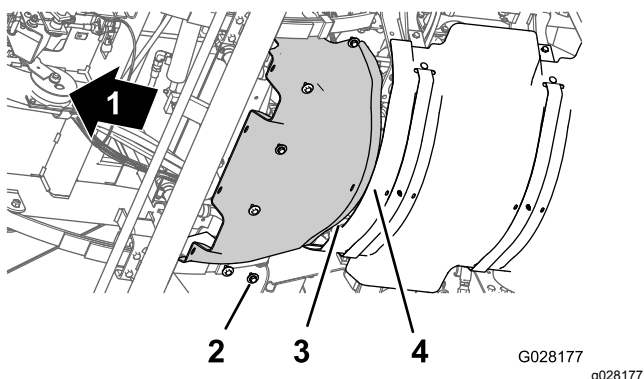

Figure 59

1. Front of the machine
2. Hex-head bolts and washers
3. Rear flange (forward heat shield)
4. Forward flange (rear heat shield)

2. Align the holes in the forward heat shield with the threaded holes in the chassis ([Figure 59](#)).
3. Assemble the forward heat shield to the machine with the 6 hex-head bolts and 6 washers ([Figure 59](#)) that you removed in step 3 of [Removing the Forward Heat Shield](#) (page 51).
4. Torque the bolts to 1,978 to 2,542 N·cm (175 to 115 in-lb).
5. Remove the jack stands and lower the machine.

Removing the Seat-Base-Access Panel

1. Remove the 2 flanged-head bolts that secure the seat-base-access panel to the seat base ([Figure 60](#)).

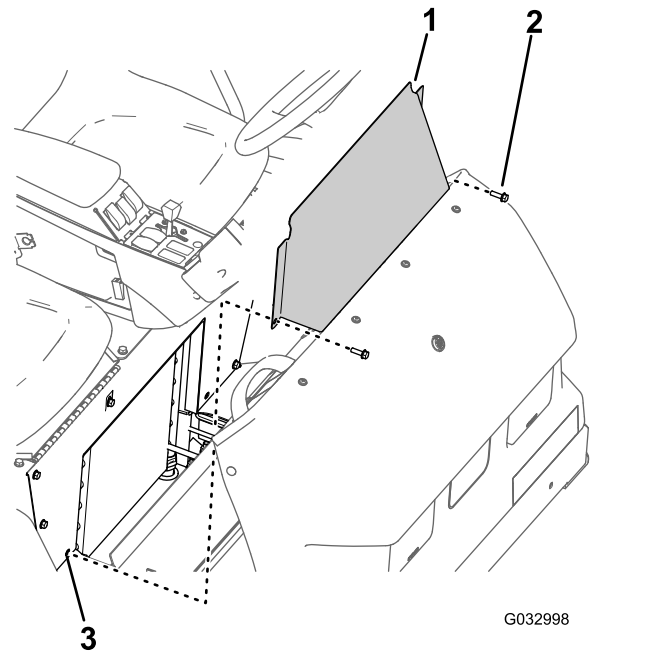

Figure 60

1. Seat-base-access panel
2. Flanged-head bolt
3. Hole (seat base)

2. Remove the seat-base-access panel from the machine ([Figure 60](#)).

Installing the Seat-Base-Access Panel

1. Align the holes in the seat-base-access panel with the holes in the seat base ([Figure 60](#)).
2. Assemble the seat-base-access panel to the seat base with the 2 flanged-head bolts ([Figure 60](#)) that you removed in step 1 of [Removing the Seat-Base-Access Panel](#) (page 51).
3. Torque the bolts to 1,975 to 2,542 N·cm (175 to 225 in-lb).

Lubrication

Greasing the Sprayer

Service Interval: Every 50 hours—Lubricate the pump.

Every 50 hours/Yearly (whichever comes first)

Grease Type: No. 2 lithium grease. Toro Premium All-Purpose Grease is available from your Toro Distributor.

1. Wipe the grease fitting clean so that foreign matter cannot be forced into the bearing or bushing.
2. Pump grease into the bearing or bushing.
3. Wipe off excess grease.

Note: The grease fittings positions are illustrated in [Figure 61](#) and [Figure 62](#).

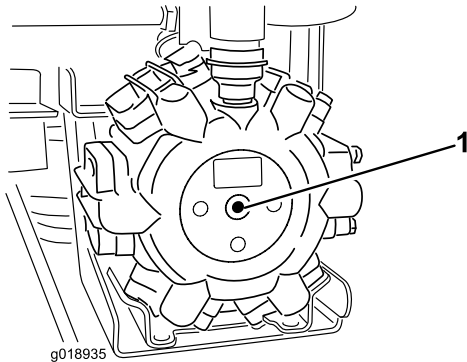

Figure 61
Pump Center

1. Grease point

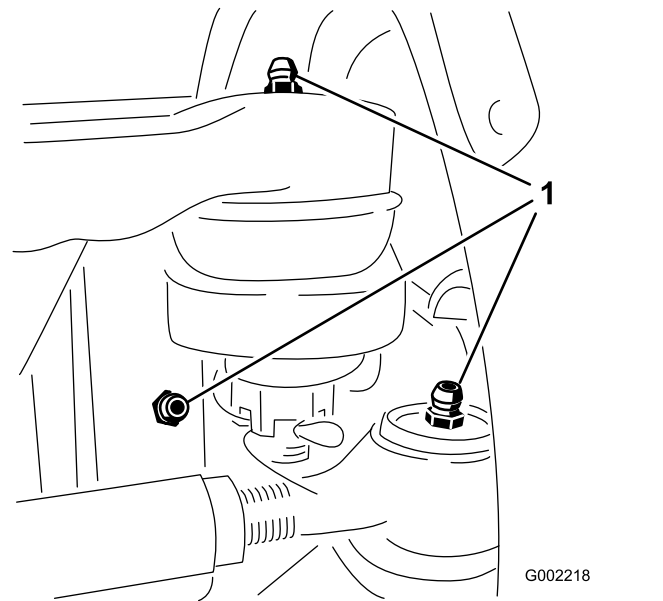

Figure 62

There are 3 fittings inside each front wheel.

1. Grease point

Greasing the Boom Hinges

Service Interval: Every 100 hours

Important: If the boom hinge is washed with water, clear all water and debris from the hinge assembly and fresh grease must be applied.

Grease Type: No. 2 lithium grease.

1. Wipe the grease fittings clean so that foreign matter cannot be forced into the bearing or bushing.
2. Pump grease into the bearing or bushing at each fitting ([Figure 63](#)).

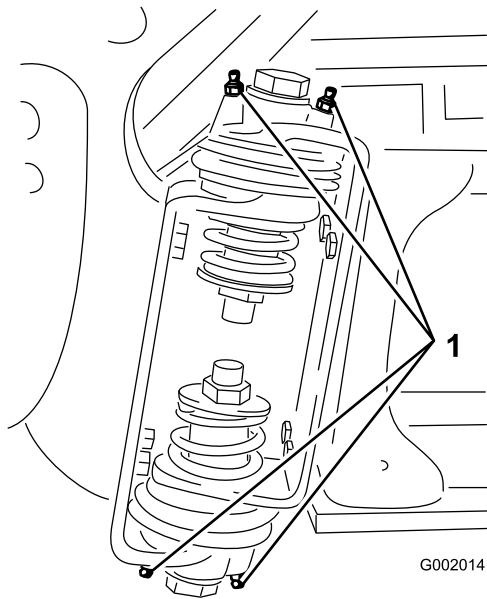

Figure 63
Right Boom

1. Grease fitting

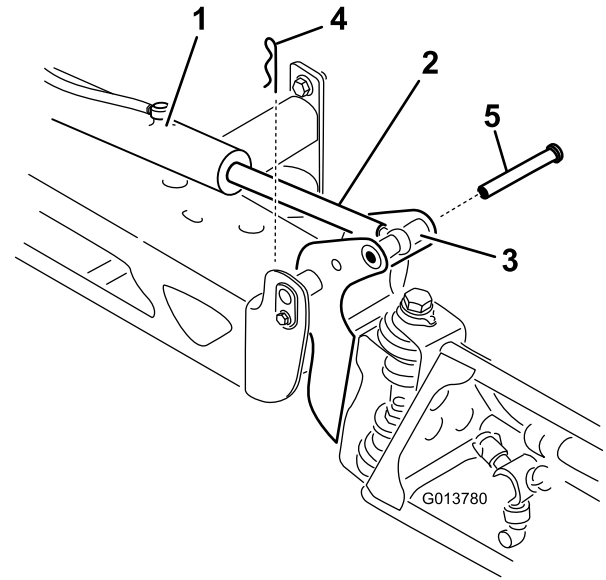

Figure 64

1. Actuator
2. Actuator rod
3. Boom-pivot-pin housing
4. Cotter
5. Pin

3. Wipe off excess grease.
4. Repeat the procedure for each boom pivot.

5. Manipulate the actuator-rod-bearing end and apply grease into the bearing (Figure 65).

Note: Wipe off excess grease.

Greasing the Actuator-Rod Bearings

Service Interval: Every 400 hours/Yearly (whichever comes first)

Grease Type: No. 2 lithium grease.

1. Extend the booms to the SPRAY position.
2. Remove the cotter pin from the pivot pin (Figure 64).
3. Lift up on the boom and remove the pin and slowly lower the boom to the ground (Figure 64).
4. Inspect the pin for any damage, replace if necessary.

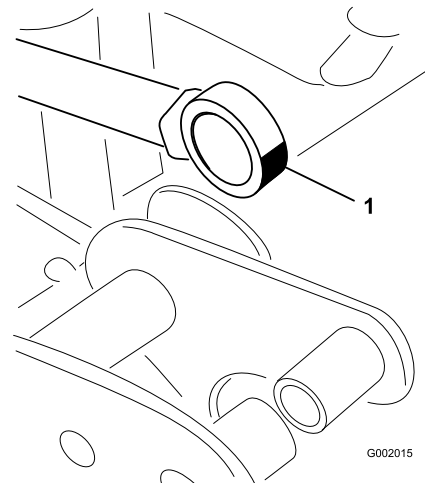

Figure 65
Right Boom

1. Grease bearing

6. Lift up on the boom to align the pivot with the actuator rod.
7. While holding the boom, insert the pin through both boom pivot and actuator rod (Figure 64).
8. With the pin in place, release the boom and secure the pin with the cotter removed previously.

- Repeat the procedure for each actuator-rod bearing.

Engine Maintenance

Checking the Air Cleaner

Service Interval: Before each use or daily Service the air cleaner more frequently if operating conditions are extremely dusty or sandy.

- Set the parking brake, stop the pump, stop the engine, and remove the key from the starter switch.
- Tilt the passenger seat forward and align the prop rod into the detent in the prop-rod-guide slot.
- Clean the dust cap and air-cleaner body (Figure 66).

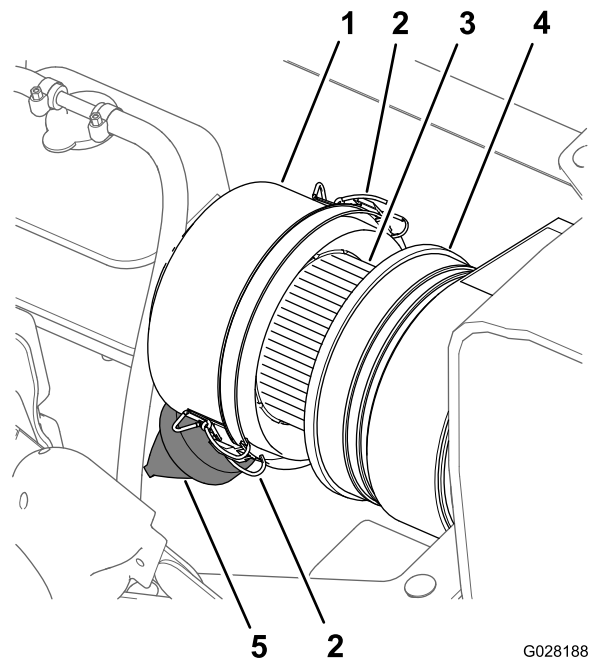

G028188
g028188

Figure 66

- | | |
|-----------------------|---------------------|
| 1. Dust cap | 4. Air-cleaner body |
| 2. Latch (dust cap) | 5. Dust valve |
| 3. Air-filter element | |

- Check the air-cleaner body for damage that could cause an air leak (Figure 66).

Note: Replace the dust cap and air-cleaner body if either is damaged.

- Squeeze the dust valve to clear it of dirt, dust, and debris (Figure 66).
- Loosen the 2 latches that secure the dust cap to the air-cleaner body.
- Check the air-filter element for excessive accumulation of dust, dirt, and debris (Figure 66).

Note: Do not clean the air-filter element if it is dirty; replace the air-filter element if it is dirty.

8. Install the dust cap onto the air-cleaner body and secure the cap with the 2 latches (Figure 66).

Note: Ensure that the dust valve aligns between the 5 to 7 o'clock position when viewed from the end.

9. Lower the passenger seat.

Replacing the Air-Filter Element

Service Interval: Every 100 hours Replace the air-filter element more often in dusty, dirty conditions.

1. If you are installing a new filter, inspect the new air-filter element for shipping damage, including the sealing end of the filter.

Important: Do not install a damaged filter.

2. Clean the dust cap and air-cleaner body (Figure 66).
3. Lift the coolant-overflow tank up and off the tank-support bracket (Figure 67).

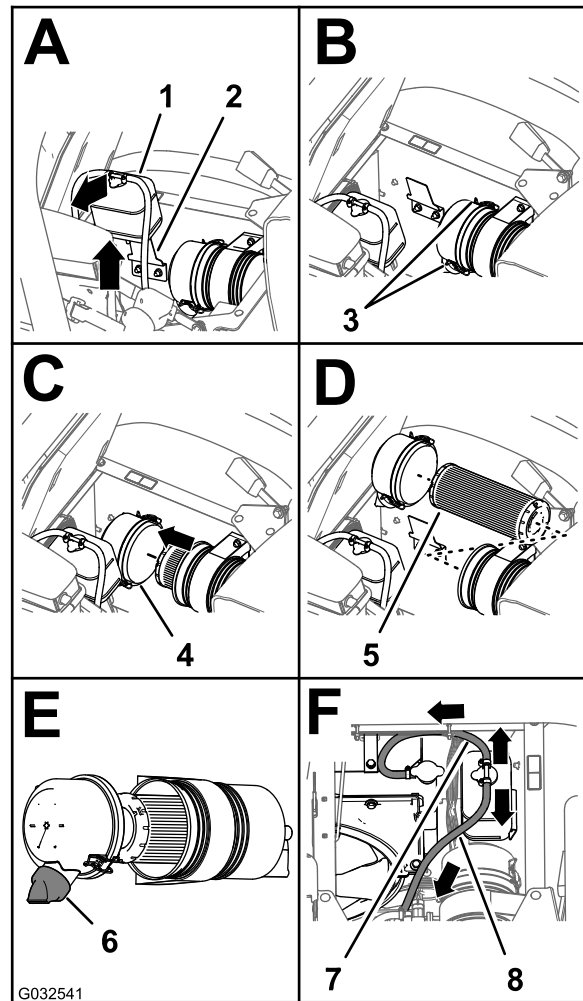

G032541

g032541

Figure 67

- | | |
|--------------------------|---|
| 1. Coolant-overflow tank | 5. Air-filter element |
| 2. Tank-support bracket | 6. Dust valve (5 to 7 o'clock position) |
| 3. Latch (dust cap) | 7. Pressure-relief hose |
| 4. Dust cap | 8. Tank-vent hose |

4. Loosen the 2 latches that secure the dust cap to the air-cleaner body (Figure 67).

5. Gently slide the old filter element out of the air-cleaner body to reduce the amount of dust dislodged.

Note: Avoid knocking the filter element against the air-cleaner body.

6. Clean the inside of the dust cap, air-cleaner body, and dust valve with a damp rag (Figure 66 and Figure 67).

7. Insert the air-filter element into the air-cleaner body (Figure 67).

Note: Ensure that the filter is seated in the air-cleaner body properly by applying pressure to the outer rim of the filter element when you install it. Do not press on the flexible center part of the filter.

- Install the cover onto the air-cleaner body and secure the cover with the 2 latches (Figure 67).

Note: Ensure that the dust valve is aligned between the 5 to 7 o'clock position when viewed from the end (Figure 67).

- Align the coolant-overflow tank to the tank-support bracket and seat the tank firmly (Figure 67).

Important: Ensure that the pressure-relief hose is routed forward and down, and the tank-vent hose is routed rearward as shown in Figure 67.

- Lower the passenger seat.

Servicing the Engine Oil

Service Interval: After the first 50 hours—Change the engine oil and oil filter.

Every 200 hours—Change the engine oil (including synthetic oil) and oil filter. Change the oil and filter more often when operating the machine under heavy load or in high temperatures.

Every 400 hours/Yearly (whichever comes first)—Complete all yearly maintenance procedures specified in the **engine operator's manual**.

Crankcase oil capacity: 5.1 L (5.4 US qt) with the filter.

- Oil type:** API service classification SL or higher.
- Oil viscosity:** refer to the engine oil viscosity table below.

Engine Oil Viscosity Table

Ambient temperature range	Oil viscosity
Above 25°C (77°F)	SAE30, SAE10W-30, or SAE15W-40
0°C to 25°C (32°F to 77°F)	SAE20 or SAE10W-30
0°C to 20°C (32°F to -4°F)	SAE10W or SAE10W-30

Toro Premium Engine Oil is available from your distributor in either 15W40 or 10W30 viscosity. Refer to the *Parts Catalog* for part numbers.

Checking the Engine Oil

Service Interval: Before each use or daily Check the engine oil level before you start the engine for the first time.

Note: The best time to check the engine oil is when the engine is cool, before it has been started for the day. If it has already ran, allow the oil to drain back

down to the sump for at least 10 minutes before checking.

The engine is shipped with oil in the crankcase; however, the level of oil must be checked before you first start the engine and after you have run it.

- Position the machine on a level surface.
- Remove the dipstick, located under the passenger seat, and wipe it with a clean rag (Figure 68).

Note: Insert the dipstick into the tube and make sure it is seated fully. Remove the dipstick and check the oil level.

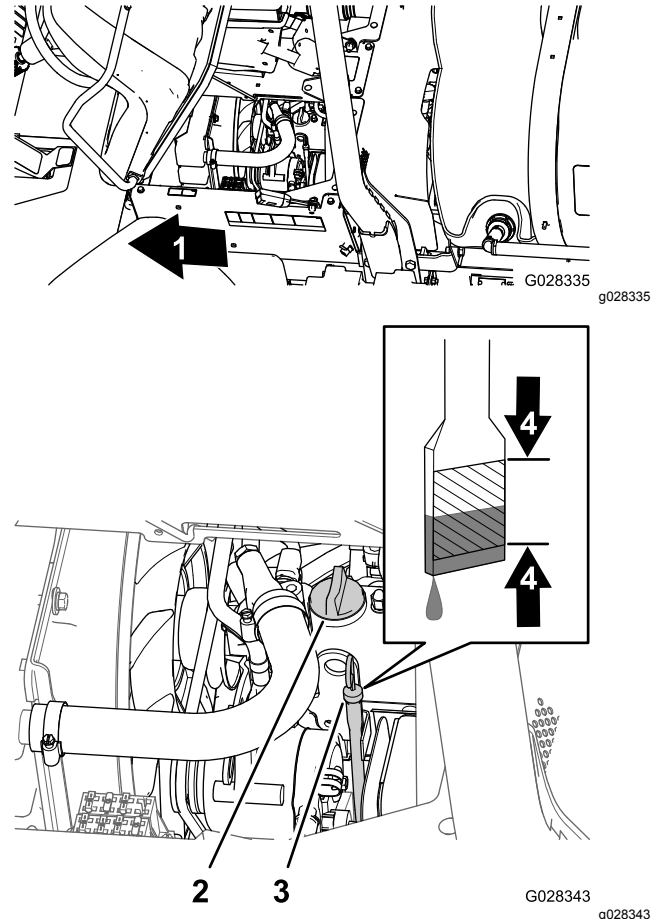

Figure 68

- Front of the machine
- Oil-filler cap
- Dip stick

- If the oil level is low, remove the filler cap from the valve cover (Figure 68) and pour oil into the filler neck until the oil level is up to the Full mark on the dipstick.

Note: Add the oil slowly and check the level often during this process. Do not overfill.

- Install the oil-filler cap (Figure 68).
- Install the dipstick firmly in place (Figure 68).

Changing the Engine-Oil Filter

1. Remove the forward heat shield; refer to [Removing the Forward Heat Shield \(page 51\)](#).
2. Raise the seats.

⚠ CAUTION

Components under the seat will be hot if the sprayer has been running. If you touch hot components, you may be burned.

Allow the sprayer to cool before performing maintenance or touching components under the hood.

3. Align a drain pan under the engine-oil filter ([Figure 69](#)).

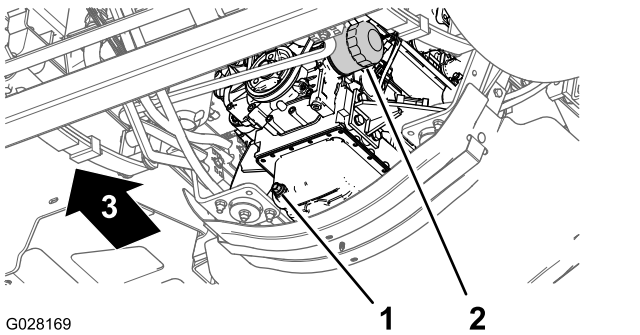

Figure 69

1. Drain plug
2. Engine-oil filter

4. Remove the old oil filter ([Figure 69](#)).

Note: Dispose of the used oil filter at a certified recycling center.

5. Wipe the surface of the oil-filter adapter of the engine with a rag.
6. Fill the oil filter with the specified oil.

Note: Allow the filter element to saturate with oil.

7. Apply a thin coat of the specified oil to the rubber gasket on the replacement oil filter.
8. Install the oil filter to the filter adapter and turn the oil filter clockwise until the rubber gasket contacts the filter adapter, then tighten the filter an additional 1/2 turn ([Figure 69](#)).

Note: Do not over tighten the oil filter.

9. Wipe clean any residual oil.

Changing the Engine Oil

1. Align a drain pan under the drain plug ([Figure 69](#)).
2. Remove the drain plug ([Figure 69](#)) and allow the oil to drain completely.

Note: Check the drain plug seal for wear and damage; replace the seal if it is worn or damaged.

Note: Dispose of the used oil at a certified recycling center.

3. Install the drain plug into the drain port of the engine oil pan and tighten the plug to 33 to 37 N·m (24 to 27 ft-lb).
4. Tilt the passenger seat forward and align the prop rod into the detent in the prop-rod-guide slot.
5. Remove the oil-filler cap from the filler neck of the valve cover of the engine ([Figure 70](#)) and slowly pour approximately 80% of the specified amount of oil into the filler neck.

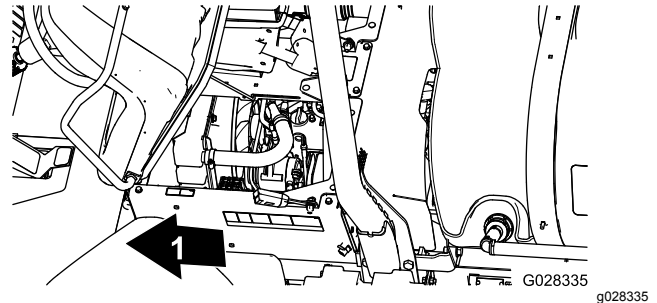

Figure 70

1. Front of the machine
2. Oil-filler cap
3. Dipstick

6. Remove the dipstick and check the oil level in the engine ([Figure 70](#)).

Fuel System Maintenance

⚠ DANGER

Under certain conditions, fuel and fuel vapors are highly flammable and explosive. A fire or explosion from fuel can burn you and others and can cause property damage.

- Use a funnel and fill the tank outdoors, in an open area, when the engine is off and is cold. Wipe up any fuel that spills.
- Do not fill the fuel tank completely full. Add fuel to the fuel tank until the level is 25 mm (1 inch) below the bottom of the filler neck. This empty space in the tank allows the fuel to expand.
- Never smoke when handling fuel, and stay away from an open flame or where fuel fumes may be ignited by a spark.
- Store fuel in a clean, safety-approved fuel container and keep the cap in place.

Checking the Fuel Line and Connections

Service Interval: After the first 50 hours

Every 400 hours/Yearly (whichever comes first)

Inspect the lines and connections for deterioration, damage, or loose connections.

Note: If you find any fuel leaks, repair the fuel component(s) before operating the machine.

Servicing the Fuel Filter

Service Interval: Every 400 hours

Removing the Fuel Pump and Sending Unit

1. Set the parking brake, stop the pump, stop the engine, and remove the key from the starter switch.
2. At the fuel tank, remove the 4 screws (#10 x 3/4 inch) that secure the cover to the top of the fuel tank, and remove the cover (Figure 72).

7. Slowly add additional specified oil to bring the oil level to the full mark on the dipstick (Figure 70).

Important: Overfilling the engine with oil may cause damage to the engine.

8. Install the oil-filler cap into the filler neck and the dipstick into the dipstick tube (Figure 70).
9. Start the engine and check for oil leaks.
10. Shut off the engine, wait 2 to 3 minutes, remove the dipstick, and check the oil level in the engine.

Note: If needed, remove the oil-filler cap, add the specified oil to bring the oil level to the full mark on the dipstick, and install the oil-filler cap.

11. Install the dipstick, engine heat shield, and tilt the seats down.

Checking the PCV Valve

Service Interval: Every 1,000 hours

1. Tilt the driver's seat forward and align the prop rod into the detent in the prop-rod-guide slot.
2. Remove the PCV valve from the fitting of the valve cover (Figure 71).

Note: Do not separate the hose from the PCV valve.

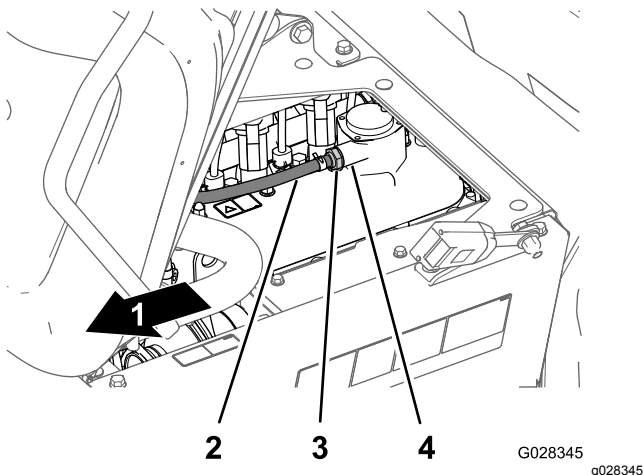

Figure 71

- | | |
|---------------------------------|------------------------|
| 1. Front of the machine | 3. PCV valve |
| 2. Hose (crankcase ventilation) | 4. Valve-cover fitting |

3. Shake the PCV valve.

Note: If the internal restrictor of the valve rattles, the PCV valve is servicable; if the internal restrictor is not free to rattle when shaken, replace the PCV valve (Figure 71).

4. Insert the PCV valve until it is fully seated in the seal for the valve-cover fitting (Figure 71).
5. Lower the driver's seat.

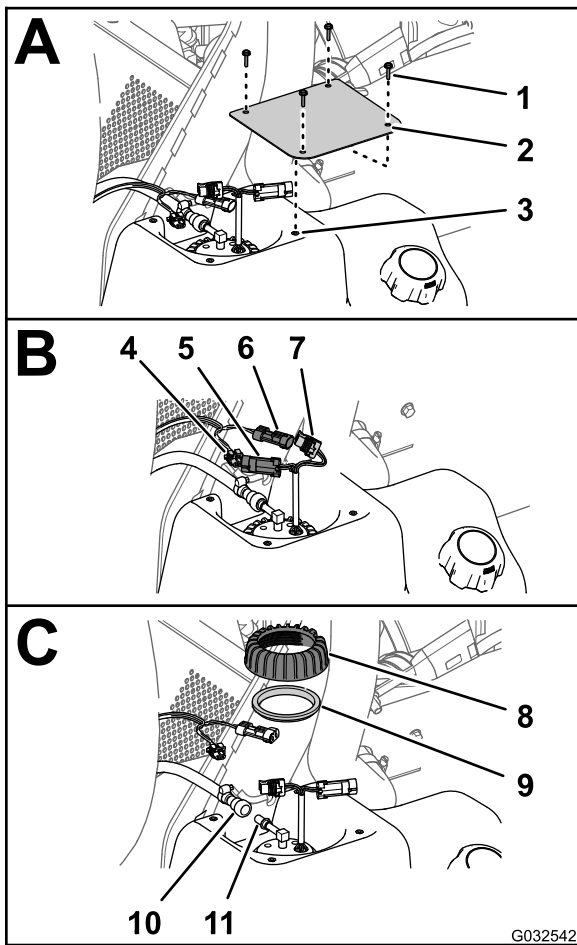

Figure 72

- | | |
|--|--|
| 1. Screws (#10 x 3/4 inch) | 7. 2-socket connector (fuel pump/sending unit) |
| 2. Cover | 8. Nut (fuel pump/sending unit) |
| 3. Fuel tank | 9. Seal |
| 4. 2-socket connector (machine—wiring harness) | 10. Fuel-hose coupling |
| 5. 2-pin connector (fuel pump/sending unit) | 11. Fitting (fuel pump) |
| 6. 2-pin connector (machine-wiring harness) | |

3. Disconnect the 2-socket connector of the machine-wiring harness from the 2-pin connector of the fuel pump/sending unit; disconnect the 2-pin connector of the machine-wiring harness from the 2-socket connector of the fuel pump/sending unit (Figure 72).
4. Slide the locking sleeve of the fuel-hose coupling away from the fitting of the fuel pump/sending unit and remove the coupling and hose from the fitting (Figure 72).

Note: Clean up any fuel that flows from the hose coupling or fuel-pump fitting.

5. Rotate the nut for the fuel pump/sending unit counterclockwise and remove the nut and seal (Figure 72)
6. Carefully lift and rotate the fuel pump/sending unit out of the neck of the fuel tank (Figure 73).

Important: Use caution when handling the fuel pump/sending unit to avoid damaging the arm for the float of the sending unit.

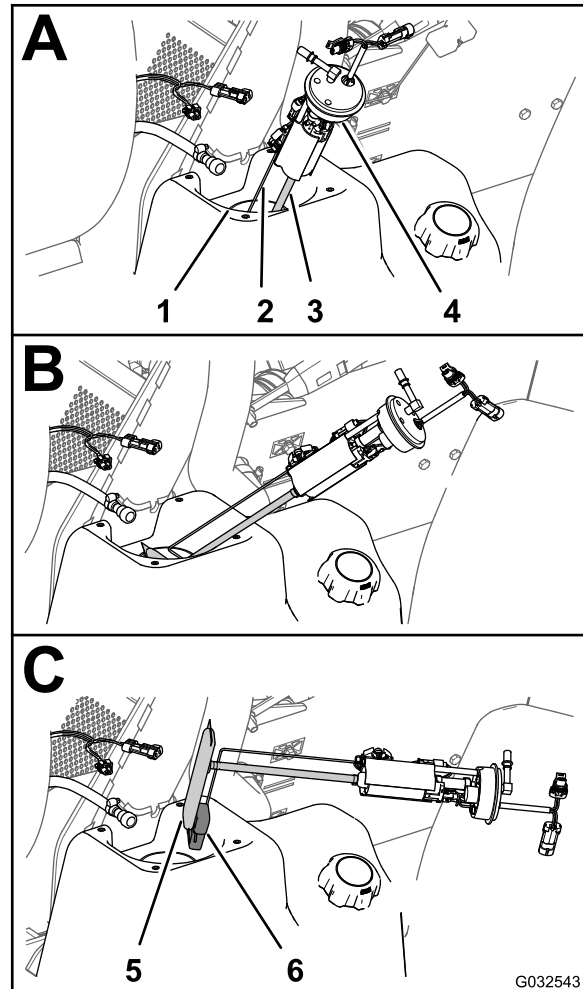

Figure 73

- | | |
|------------------------------|---------------------------|
| 1. Fuel-tank neck | 4. Fuel pump/sending unit |
| 2. Arm (sending-unit float) | 5. Filter |
| 3. Pickup tube (fuel filter) | 6. Float |

Replacing the Fuel Filter

1. Remove the pickup tube of the fuel filter from the fitting of the fuel pump (Figure 74).

Note: Discard the fuel filter.

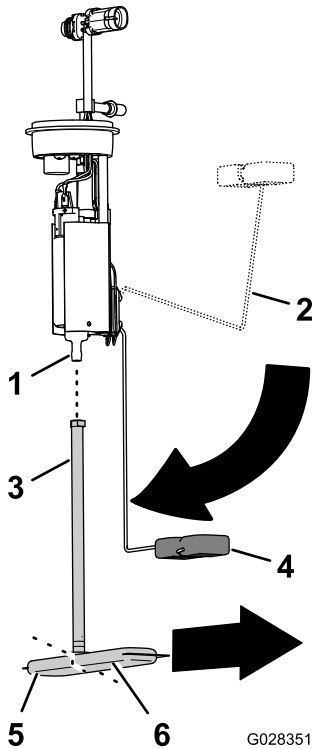

Figure 74

- | | |
|------------------------------|-------------------------------|
| 1. Fitting (fuel pump) | 4. Float arm (empty position) |
| 2. Float arm (full position) | 5. Fuel filter (short leg) |
| 3. Pickup tube | 6. Fuel filter (long leg) |

2. Align the pickup tube of the new fuel filter with the fitting of the fuel pump (Figure 74).
3. Align the long leg of the fuel filter with float when the float arm is in the empty position (Figure 74).
4. Insert the fuel-pump fitting into the pickup tube until the fitting is fully seated (Figure 74).

Installing the Fuel Pump and Sending Unit

1. Support the float arm and pickup tube together and slip the float and fuel filter into the opening in the fuel tank (Figure 73).

Important: Ensure that the float and the long leg of the filter are pointing forward in the tank and the fitting at the top of the fuel pump points 90° toward the centerline of the machine.

2. Seat the fuel pump/sending unit into the opening in the tank (Figure 73 and Figure 74).
3. Install the seal and nut over the fuel pump/sending and onto the neck of the fuel tank and tighten the nut hand tight (Figure 73).
4. Connect the coupling on the fuel hose to the fitting of the fuel pump (Figure 73).

Note: Ensure that the locking sleeve of the fuel-hose coupling secures the coupling to the pump fitting.

5. Connect the 2-socket connector of the machine-wiring harness to the 2-pin connector of the fuel pump/sending unit; Connect the 2-pin connector of the machine-wiring harness to the 2-socket connector of the fuel pump/sending unit (Figure 73).
6. Rotate the starter switch to the ON position and check the fuel-hose coupling for leaks.

Note: If the coupling leaks, rotate the starter switch to the OFF position, remove the key, remove the coupling, check the coupling and fitting for dirt or damage, and install the hose and coupling onto the fitting.

Note: Repair any fuel leaks before proceeding to the next step.

7. Assemble the cover to the tank with the and 4 screws (#10 x 3/4 inch) that you removed in step 2 of [Removing the Fuel Pump and Sending Unit](#) (page 58).
8. Torque the screws to 113 N•cm (10 in-lbs).

Draining the Fuel Tank

Service Interval: Every 400 hours/Yearly (whichever comes first)

Drain and clean the fuel tank if the fuel system becomes contaminated or if you plan to store the machine for an extended period. When cleaning the fuel tank, use fresh, clean fuel to flush out the tank.

1. Transfer the fuel from the tank into an approved fuel container using a siphon pump, or from the machine before you pour the fuel out of the tank fill spout into the fuel container.

Note: If you remove the fuel tank, you will need to disconnect the fuel hose and electrical connectors from the fuel pump and sending unit; refer to [Removing the Fuel Pump and Sending Unit \(page 58\)](#).

2. Flush the tank with fresh, clean fuel, if necessary.
3. Replace the fuel filters; refer to [Replacing the Fuel Filter \(page 60\)](#).
4. Install the tank if you removed it in step 1.

Note: If you remove the fuel tank, you will need to connect the fuel hose and electrical connectors to the fuel pump and sending unit ; refer to [Installing the Fuel Pump and Sending Unit \(page 60\)](#).

5. Fill the tank with fresh, clean fuel.

Bleeding the Fuel System

Use this procedure after you have serviced the fuel filter or ran the engine out of fuel, and the engine does not start.

1. Ensure that you have 1/2 tank of fuel in the fuel tank.
2. Insert the key into the starter switch and rotate it to the ON position.
3. Rotate the key to the OFF position.
4. Attempt to start the engine.
5. If the engine does not start, repeat steps 2 and 3 several times and then attempt to start the engine.

Note: Repeat step 5 until the engine starts.

Electrical System Maintenance

Replacing the Fuses

The fuse block for the electrical system is located beneath the operator's seat ([Figure 75](#)).

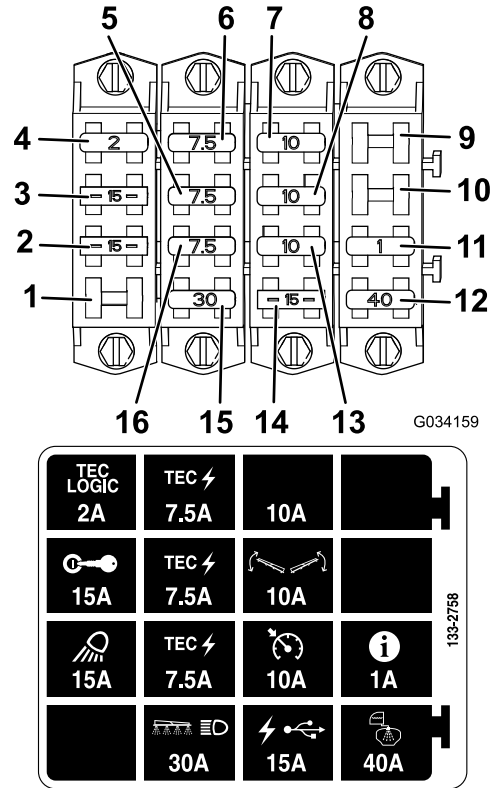

Figure 75

- | | |
|--------------------|------------------------|
| 1. Open slot | 9. Open slot |
| 2. Work light | 10. Open slot |
| 3. Ignition | 11. InfoCenter |
| 4. Tec Logic | 12. Tank spray |
| 5. Tec power | 13. Cruise control |
| 6. Tec power | 14. USB power |
| 7. Extra fuse slot | 15. Boom and headlight |
| 8. Boom control | 16. Tec power |

Servicing the Battery

WARNING

CALIFORNIA Proposition 65 Warning

Battery posts, terminals, and related accessories contain lead and lead compounds, chemicals known to the State of California to cause cancer and reproductive harm. **Wash hands after handling.**

Always keep the battery clean and fully charged. Use a paper towel to clean the battery and battery box. If the battery terminals are corroded, clean them with a solution of 4 parts water and 1 part baking soda. Apply a light coating of grease to the battery terminals to prevent corrosion.

Voltage: 12 V with 690 cold cranking amps at 0°F (-18°C)

Removing the Battery

1. Position the sprayer on a level surface, set the parking brake, stop the pump, stop the engine, and remove the key from the starter switch.
2. Remove the battery cover and disconnect the negative (black) ground cable from the battery post (Figure 76).

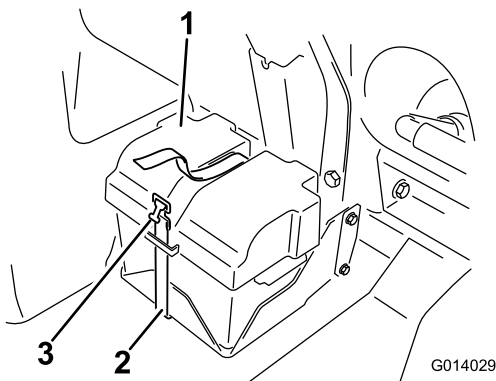

Figure 76

1. Battery cover
2. Strap
3. Buckle

▲ WARNING

Incorrect battery cable routing could damage the sprayer and cables causing sparks. Sparks can cause the battery gasses to explode, resulting in personal injury.

- Always *disconnect* the negative (black) battery cable before disconnecting the positive (red) cable.
- Always *reconnect* the positive (red) battery cable before reconnecting the negative (black) cable.

▲ WARNING

Battery terminals or metal tools could short against metal sprayer components causing sparks. Sparks can cause the battery gasses to explode, resulting in personal injury.

- When removing or installing the battery, do not allow the battery terminals to touch any metal parts of the sprayer.
- Do not allow metal tools to short between the battery terminals and metal parts of the sprayer.
- Always keep the battery strap in place to protect and secure the battery.

3. Disconnect the positive (red) cable from the battery post.
4. Remove the battery.

Installing the Battery

1. Set the battery on the battery box so that the battery posts are away from the sprayer.
2. Connect the positive (red) cable to the positive (+) battery post and the negative (black) cable to the negative (-) battery post using the bolts and nuts.
3. Slide the rubber boot over both battery posts.
4. Install the battery cover and secure it with the strap removed previously (Figure 76).

Important: Always keep the battery retainer in place to protect and secure the battery.

Charging the Battery

Important: Always keep the battery fully charged. This is especially important to prevent battery damage when the temperature is below 32°F (0°C).

1. Remove the battery from the chassis; refer to [Removing the Battery \(page 62\)](#).
2. Connect a 3 to 4 A battery charger to the battery posts and charge the battery at a rate of 3 to 4 A for 4 to 8 hours (12 V).

Important: Do not overcharge the battery.

3. Install the battery in the chassis; refer to [Installing the Battery \(page 62\)](#).

Storing the Battery

If the machine will be stored for more than 30 days, remove the battery and charge it fully. Either store it on a shelf or on the machine. Leave the cables disconnected if it is stored on the machine. Store the battery in a cool atmosphere to avoid quick deterioration of the charge in the battery. To prevent the battery from freezing, ensure that it is fully charged.

Drive System Maintenance

Inspecting the Wheels/Tires

Service Interval: After the first 8 hours—Torque the wheel-lug nuts.

Every 100 hours—Torque the wheel-lug nuts.

Every 100 hours—Inspect the condition and wear of the tires.

Torque the front lug nuts to 75 to 102 N·m (55 to 75 ft-lb) and the rear lug nuts to 95 to 122 N·m (75 to 90 ft-lb).

Operating accidents, such as hitting curbs, can damage a tire or rim and also disrupt wheel alignment, so inspect tire condition after an accident.

Changing the Planetary-Gearbox Fluid

Service Interval: After the first 8 hours

Every 400 hours

Use high quality, SAE 85W-140 weight gear lube.

1. Position the sprayer on a level surface with the rear wheels positioned for draining ([Figure 77](#)).

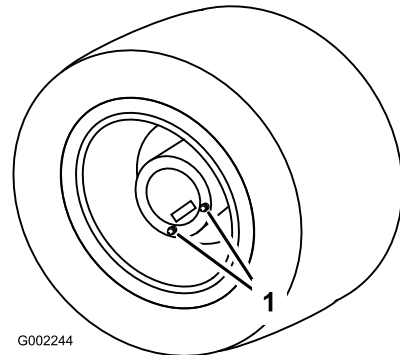

Figure 77

1. Drain plugs
-
2. Set the parking brake, stop the pump, stop the engine, and remove the key from the starter switch.
 3. Place a drain pan under the drain plugs and remove them from the wheel ([Figure 77](#)).
 4. Place a pan under the inner drain plug and remove it ([Figure 78](#)).

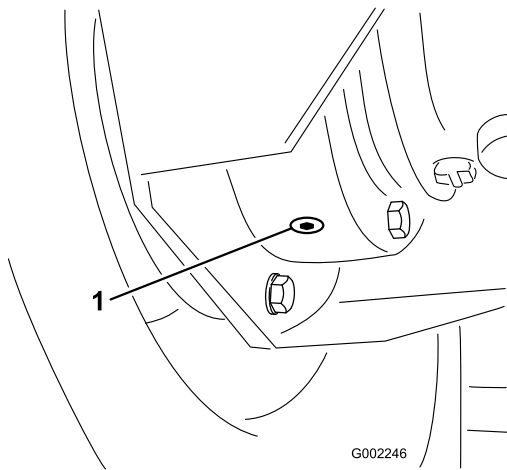

Figure 78

1. Inner drain plug

5. Move the vehicle slowly until the wheel is positioned for filling ([Figure 79](#)).

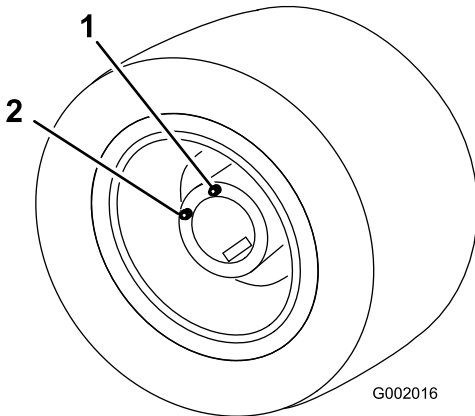

Figure 79

1. Upper hole—add fluid
2. Lower hole here

6. Set the parking brake, stop the pump, stop the engine, and remove the key from the starter switch.
7. Pour SAE 85W-140 weight gear lube into the upper hole until it begins to come out of the lower hole.
8. Replace and tighten all drain plugs.
9. Repeat steps 3 through 9 for the other rear wheel.
10. Dispose of the used oil at a certified recycling center.

Adjusting the Front Wheel Toe-in

Service Interval: Every 200 hours/Yearly (whichever comes first)

The toe-in should be 0 to 3 mm (0 to 1/8 inch).

1. Check and fill all tires; refer to [Checking the Tire Pressure](#) (page 36).
2. Measure the distance between both of the front tires at the axle height at both the front and rear of the front tires ([Figure 80](#)).

Note: The distance between the front of the tires should be 0 to 3 mm (0 to 1/8 inch) less than the distance between the back side of the front tires.

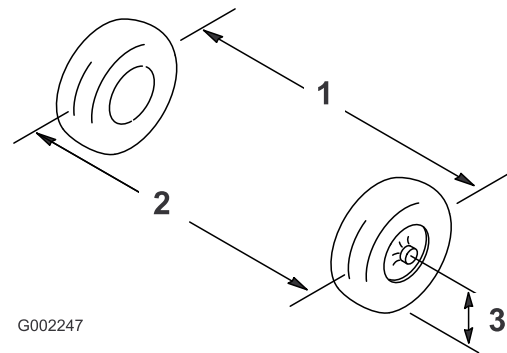

Figure 80

1. Tire center line—back
2. Tire center line—front
3. Axle center line

3. If the measurement does not fall within the specified range, loosen the jam nuts at both ends of the tie rod ([Figure 81](#)).

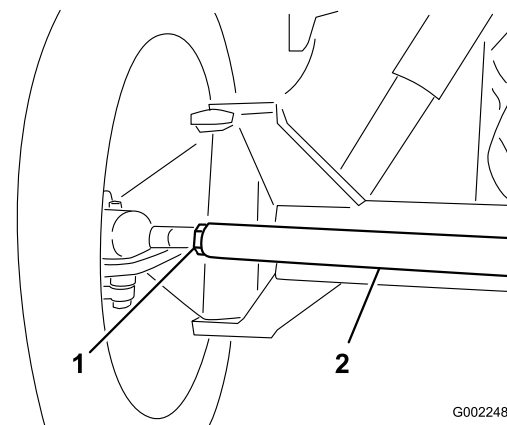

Figure 81

1. Jam nut
2. Tie rod

4. Rotate the tie rod to move the front of the tire inward or outward.

5. Tighten the tie rod jam nuts when the adjustment is correct.
6. Ensure that there is full travel of the steering wheel in both directions.

Cooling System Maintenance

Servicing the Cooling System

Service Interval: Every 100 hours—Check the cooling-system hoses for wear and damage.

Cooling system capacity: 5.5 L (5.8 US qt)

Coolant type: a solution of 50% water and 50% permanent ethylene glycol antifreeze

Important: Do not add coolant to an overheated engine until the engine has fully cooled. Adding coolant to an overheated engine may crack the engine block.

Check the engine-coolant concentration as directed by the coolant manufacturer.

Checking the Coolant Level

Service Interval: Before each use or daily Check the level of coolant in the radiator and the expansion tank at the beginning of each day before starting the engine.

⚠ CAUTION

If the engine has been running, the coolant may be hot and pressurized. If you open the radiator cap when the coolant is hot, it could spray out and severely burn you or bystanders.

Allow the engine to cool for at least 15 minutes before opening the radiator cap.

1. Position the sprayer on a level surface.
2. Set the parking brake, stop the pump, stop the engine, and remove the key from the starter switch.
3. Carefully remove the radiator cap and the expansion-tank cap ([Figure 82](#)).

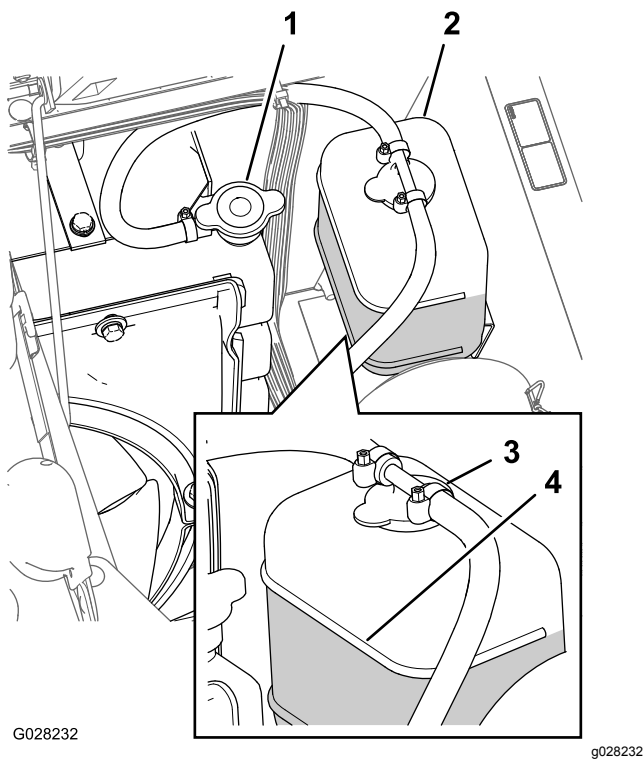

Figure 82

- | | |
|-------------------|-----------------------|
| 1. Radiator cap | 3. Expansion-tank cap |
| 2. Expansion tank | 4. Full-line mark |

4. Check the coolant level in the radiator and in the expansion tank.

Note: The radiator should be filled to the top of the filler neck and the expansion tank filled to the Full mark on the tank (Figure 82).

5. If the coolant level is low, remove the expansion-tank cap and the radiator cap, and fill the expansion tank to the Full mark and the radiator to the top of the filler neck (Figure 82).

Important: Do not overfill the expansion tank.

Important: Do not use water only or an alcohol/methanol-based coolant.

6. Install the radiator cap and the expansion-tank cap (Figure 82).

Changing the Cooling-System Fluid

Service Interval: Every 400 hours/Yearly (whichever comes first)—Check the coolant (as directed by the manufacturer) and change if necessary.

1. Position the sprayer on a level surface, set the parking brake, stop the pump, stop the engine, and remove the key from the starter switch.

2. When the engine is cool, remove the radiator cap (Figure 82).
3. Place a large drain pan under the radiator.
4. Open the drain valve and drain the coolant into the pan (Figure 83).

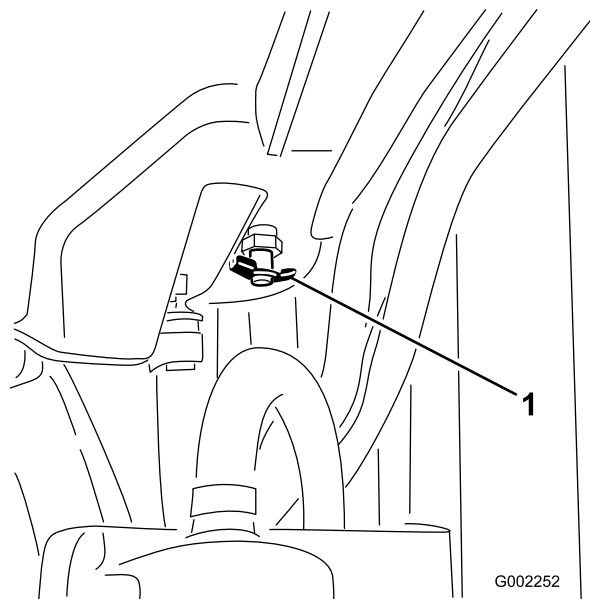

Figure 83

1. Drain valve

5. Close the drain valve (Figure 83).
6. Remove the radiator cap (Figure 82).
7. Slowly fill the radiator with coolant to approximately 2.5 cm (1 inch) below the sealing surface of the cap.

Note: Use enough coolant to fill the engine and the system lines. This allows the coolant to expand without it overflowing while the engine is warming up.

8. Start the engine with the cap loosely on the radiator (Figure 82).
9. Allow the engine to warm up until the thermostat opens.

Note: This usually occurs between 79° to 88°C (175° to 190°F).

10. Once the coolant has warmed up, top off the coolant level to the sealing surface of the cap and tighten the cap (Figure 82).
11. Open the expansion-tank cap and fill the tank with coolant to the Cold level (Figure 82).
12. Check the coolant levels after several engine startup and shut-down cycles.

Note: Add coolant to the radiator and expansion tank as needed.

Brake Maintenance

Adjusting the Brakes

If the brake pedal travels more than 2.5 cm (1 inch) before you feel resistance, adjust the brakes as follows:

1. Position the sprayer on a level surface, stop the pump, stop the engine, and remove the key from the starter switch.
2. Set the parking brake.
3. Put blocks under the wheels to prevent the machine from rolling.
4. Release the parking brake.
5. Loosen the front nuts on the brake cables under the front end of the sprayer (Figure 84).

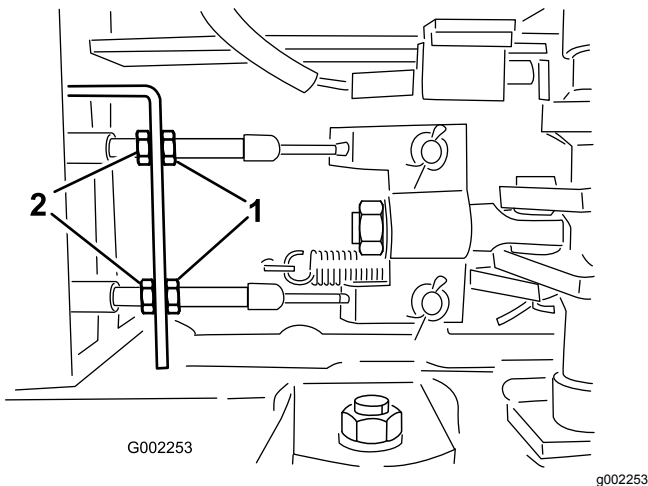

Figure 84

1. Front nuts
2. Rear nuts

6. Tighten the rear nuts equally until the brake pedal moves between 1 to 2 cm (1/2 to 1 inch) before you feel resistance (Figure 84).

Important: Ensure that you tighten both rear nuts equally so that the threaded ends of the brake cables in front of the front nuts are the same length.

7. Tighten the front nuts.

Belt Maintenance

Servicing the Alternator Belt

Service Interval: After the first 8 hours

Every 100 hours

Check the condition and tension of the alternator/cooling fan belt. Replace the belt as necessary.

1. Position the sprayer on a level surface, set the parking brake, stop the pump, stop the engine, and remove the key from the starter switch.
2. Check the tension by depressing the belt midway between the alternator and the crankshaft pulleys with 10 kg (22 lb) of force.

Note: The belt should deflect 10 to 12 mm (0.39 to 0.47 inches). If the deflection is not correct, go to 3. If it is correct, you may skip the remainder of this procedure and resume operating the sprayer.

3. Loosen the bolts that secure the brace to the engine and the bolt that secures the alternator to the brace (Figure 85).

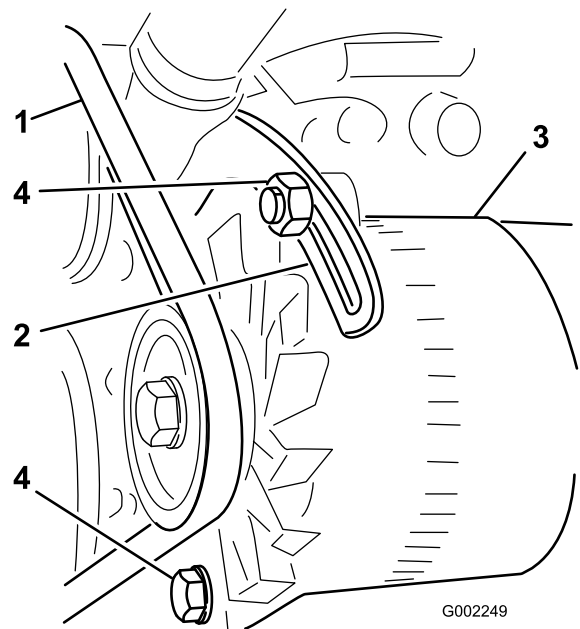

Figure 85

1. Alternator belt
2. Brace
3. Alternator
4. Bolts

4. Insert a pry bar between the alternator and the engine and carefully pry on the alternator outward.

5. When you achieve the proper tension, tighten the alternator and the bolts to secure the adjustment.
6. Tighten the locknut to secure the adjustment.

Hydraulic System Maintenance

Checking the Hydraulic Fluid

Service Interval: Before each use or daily Check the level of the hydraulic fluid before the engine is first started and daily thereafter.

Hydraulic fluid specifications: Toro Premium All Season Hydraulic Fluid

Note: Available in 19 L (5 US gallons) pails or 208 L (55 US gallons) drums. See the parts catalog or your Authorized Toro Distributor for part numbers.

Alternate hydraulic fluids: If the Toro fluid is not available, other fluids may be used provided they meet all the following material properties and industry specifications. We do not recommend the use of synthetic fluid. Consult with your lubricant distributor to identify a satisfactory product.

Note: Toro will not assume responsibility for damage caused by improper substitutions, so use only products from reputable manufacturers who will stand behind their recommendation.

High Viscosity Index/Low Pour Point Anti-wear Hydraulic Fluid, ISO VG 46

Material Properties:

Viscosity, ASTM D445	cSt @ 40°C 44 to 48 cSt @ 100°C 7.9 to 8.5
Viscosity Index ASTM D2270	140 to 160
Pour Point, ASTM D97	-34°F to -49°F

Industry Specifications:

Vickers I-286-S (Quality Level), Vickers M-2950-S (Quality Level), Denison HF-0

Important: The ISO VG 46 Multigrade fluid has been found to offer optimal performance in a wide range of temperature conditions. For operation in consistently high ambient temperatures, 18° C (65° F) to 49° C (120° F), ISO VG 68 hydraulic fluid may offer improved performance.

Premium Biodegradable Hydraulic Fluid-Mobil EAL EnviroSyn 46H

Important: Mobil EAL EnviroSyn 46H is the only synthetic biodegradable fluid approved by Toro. This fluid is compatible with the elastomers used in Toro hydraulic systems and is suitable for a wide-range of temperature conditions. This fluid is compatible with conventional mineral oils, but for maximum biodegradability and performance the hydraulic system should be thoroughly flushed of conventional fluid. The oil is available in 19 L (5

US gallons) pails or 208 L (55 US gallons) from your Mobil Distributor.

1. Position the sprayer on a level surface, set the parking brake, stop the sprayer pump, stop the engine, and remove the key from the starter switch.
2. Clean the area around the hydraulic-fluid-tank dipstick cap and remove it (Figure 86).

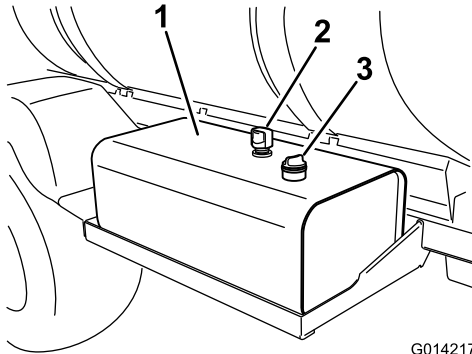

Figure 86

1. Hydraulic-fluid tank
2. Vent
3. Dipstick cap

Important: Be very careful not to get dirt or other contaminants into the opening when checking the fluid.

3. Wipe the dipstick clean with a cloth and replace it completely in the tank.
4. Remove the dipstick from the filler neck and check the fluid level (Figure 87).

Note: The fluid level should be within the safe-operating range on the dipstick.

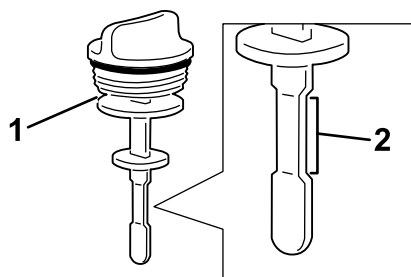

Figure 87

1. Dipstick
2. Safe-operating range

5. If the fluid is low, fill the tank with the specified hydraulic fluid or equivalent to raise the level to the upper mark.
6. Install the dipstick cap into the tank and secure.

Servicing the Hydraulic Fluid

If the fluid becomes contaminated, contact an Authorized Toro Distributor to have the system flushed.

Note: Contaminated fluid looks milky or black when compared to clean fluid.

Replacing the Hydraulic-Fluid Filters

Service Interval: After the first 5 hours

Every 400 hours/Yearly (whichever comes first)

Use the Toro replacement filter (See your *Parts Manual* for the correct part number.)

Important: Use of any other filter may void the warranty on some components.

⚠ WARNING

Hot hydraulic fluid can cause severe burns.

Allow the hydraulic fluid to cool before performing any maintenance to the hydraulic system.

1. Position the sprayer on a level surface, set the parking brake, stop the pump, stop the engine, and remove the key from the starter switch.
2. Locate the 2 hydraulic filters on the machine (Figure 88 and Figure 89).

Note: One is below the hydraulic-fluid tank and the other is at the rear of the machine on the frame.

- Forward filter—below the hydraulic tank.

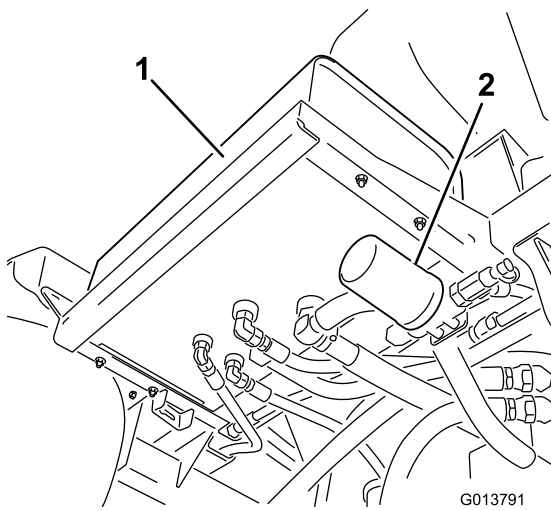

Figure 88

1. Hydraulic tank 2. Forward filter

- Rear filter—located on the machine frame.

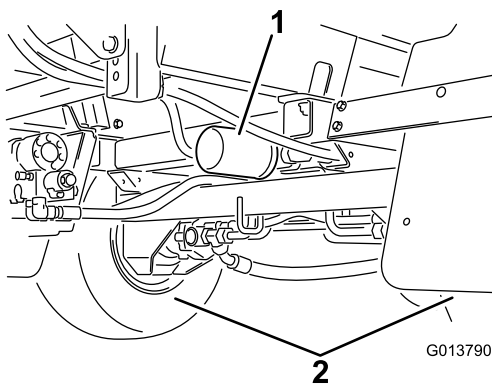

Figure 89

1. Rear filter 2. Rear wheels

3. Clean the area around the filter-mounting area.
4. Place a drain pan under the filter.
5. Remove the filter.
6. Lubricate the new filter gasket.
7. Ensure that the filter-mounting area is clean.
8. Screw the filter on until the gasket contacts the mounting plate, then tighten the filter 1/2 turn.
9. Start the engine and let it run for about 2 minutes to purge air from the system.
10. Stop the engine and check the hydraulic-fluid level and for leaks.
11. Dispose of the used filter at a certified recycling center.

Changing the Hydraulic Fluid

Service Interval: Every 400 hours/Yearly (whichever comes first)

Hydraulic-fluid capacity: 56 L (15 US gallons) of the specified hydraulic fluid or equivalent; refer to [Servicing the Hydraulic Fluid \(page 69\)](#).

Important: Using any other fluid may void the warranty on some components.

⚠ WARNING

Hot hydraulic fluid can cause severe burns.

Allow the hydraulic fluid to cool before performing any maintenance to the hydraulic system.

1. Replace the hydraulic-fluid filters; refer to [Replacing the Hydraulic-Fluid Filters \(page 69\)](#).
2. Clean the area around a hydraulic-hose fitting on the bottom of the hydraulic-fluid tank ([Figure 90](#)).

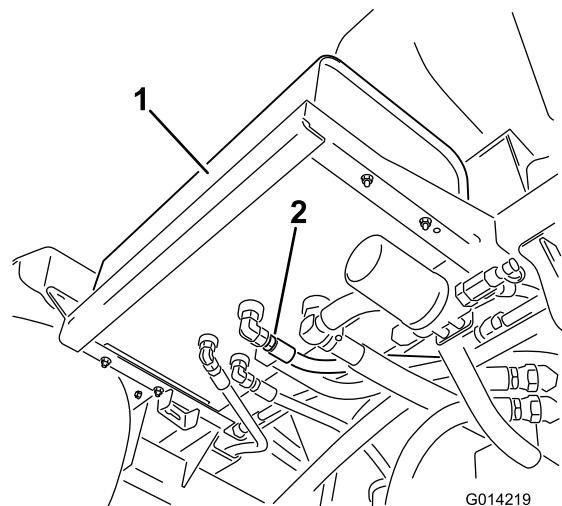

Figure 90

1. Hydraulic tank 2. Hydraulic hose and fitting

3. Place a large drain pan under the fitting.
4. Remove the hose fitting from the tank, allowing the fluid to drain into the pan ([Figure 90](#)).
5. Install the hose and fitting to the tank and tighten it securely.
6. Fill the hydraulic reservoir with approximately 53 L (14 US gallons) of specified hydraulic fluid or equivalent; refer to [Servicing the Hydraulic Fluid \(page 69\)](#).
7. Start the machine and run it at IDLE for 3 to 5 minutes to circulate the fluid and remove any air trapped in the system.
8. Stop the engine, check the hydraulic-fluid level, and check for leaks.

9. Dispose of the used fluid at a certified recycling center.

Checking the Hydraulic Lines and Hoses

Inspect the hydraulic lines and hoses daily for leaks, kinked lines, loose mounting supports, wear, loose fittings, weather deterioration, and chemical deterioration. Make all necessary repairs before operating.

⚠ WARNING

Hydraulic fluid escaping under pressure can penetrate skin and cause injury.

- Ensure that all hydraulic fluid hoses and lines are in good condition and all hydraulic connections and fittings are tight before applying pressure to the hydraulic system.
- Keep your body and hands away from pin hole leaks or nozzles that eject high-pressure hydraulic fluid.
- Use cardboard or paper to find hydraulic leaks.
- Safely relieve all pressure in the hydraulic system before performing any work on the hydraulic system.
- Get immediate medical help if fluid is injected into the skin.

Sprayer System Maintenance

⚠ WARNING

Chemical substances used in the spray system may be hazardous and toxic to you, bystanders, animals, plants, soils or other property.

- Carefully read and follow the chemical warning labels and Material Safety Data Sheets (MSDS) for all chemicals used and protect yourself according to the chemical manufacturer's recommendations. For example, use appropriate Personal Protective Equipment (PPE) including face and eye protection, gloves, or other equipment to guard against personal contact with the chemical.
- Keep in mind that there may be more than one chemical used and information on each should be assessed.
- *Refuse to operate or work on the sprayer if this information is not available!*
- Before working on a spray system make sure the system has been triple rinsed and neutralized according to the recommendations of the chemical manufacturer(s) and all of the valves have been cycled 3 times.
- Verify there is an adequate supply of clean water and soap nearby, and immediately wash off any chemicals that contact you.

Inspecting the Hoses

Service Interval: Every 200 hours—Inspect all hoses and connections for damage and proper attachment.

Every 400 hours/Yearly (whichever comes first)—Inspect the O-rings in the valve assemblies. Replace the O-rings if necessary

Examine each hose in the spray system for cracks, leaks or other damage. At the same time, inspect the connections and fittings for similar damage. Replace any hoses and fittings if damaged.

Changing the Pressure Filter

9. Install the plug into the bowl hand tight (Figure 91).

Service Interval: Every 400 hours

1. Move the machine to a level surface, shut off the sprayer pump, shut off the engine, and remove the key from the starter switch.
2. Align a drain pan under the pressure filter (Figure 91).

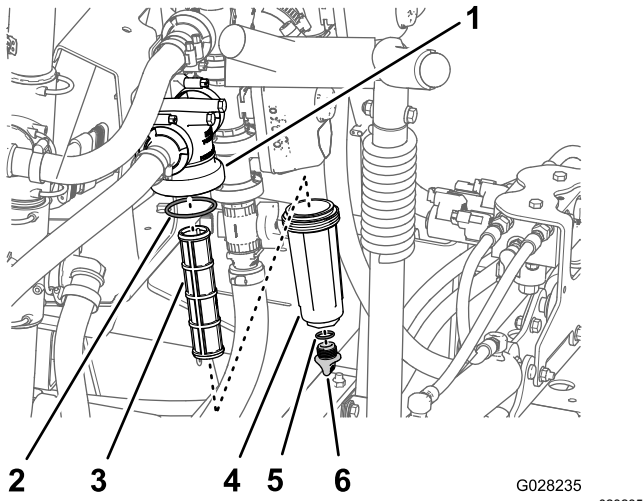

Figure 91

- | | |
|-------------------|------------------------|
| 1. Filter head | 4. Bowl |
| 2. O-ring (bowl) | 5. O-ring (drain plug) |
| 3. Filter element | 6. Drain plug |

3. Rotate the drain plug counterclockwise and remove it from the bowl of the pressure filter (Figure 91).

Note: Allow the bowl to drain completely.

4. Rotate the bowl counterclockwise and remove it from its filter head (Figure 91).
5. Remove the old pressure-filter element (Figure 91).

Note: Discard the old filter.

6. Check the O-ring for the drain plug (located inside the bowl) and the O-ring for the bowl (located inside the filter head) for damage and wear (Figure 91).

Note: Replace any damaged or worn O-rings for the plug, bowl, or both.

7. Install the new pressure-filter element into the filter head (Figure 91).

Note: Ensure that the filter element is firmly seated into the filter head.

8. Install the bowl onto the filter head hand tight (Figure 91).

Spray System Schematic

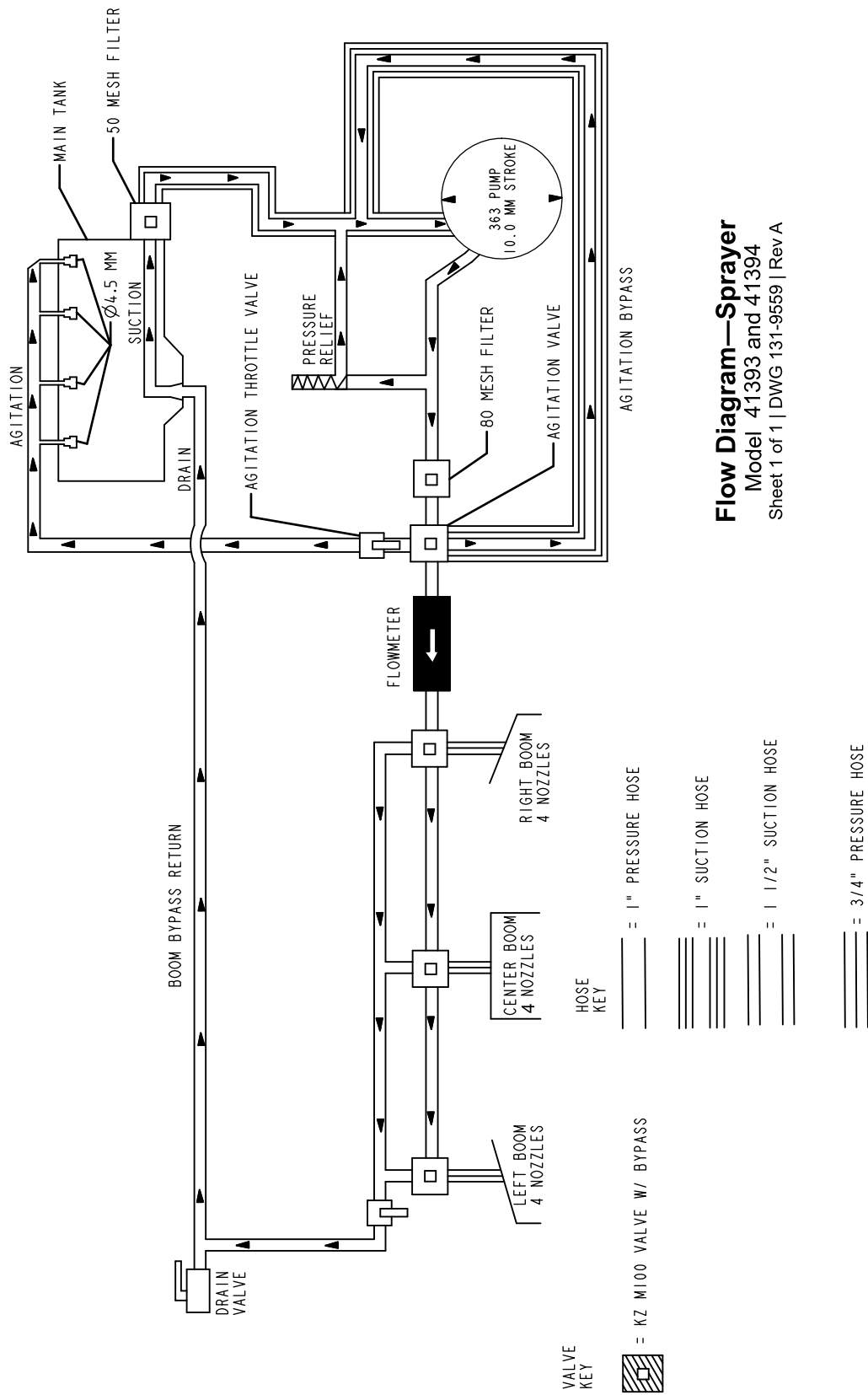

Flow Diagram—Sprayer
 Model 41393 and 41394
 Sheet 1 of 1 | DWG 131-9559 | Rev A

Figure 92

G034336

g034336

Pump Maintenance

Inspecting the Pump

Service Interval: Every 400 hours/Yearly (whichever comes first)—Inspect the pump diaphragm and replace if necessary. (see an Authorized Toro Service Distributor).

Every 400 hours/Yearly (whichever comes first)—Inspect the pump check valves and replace if necessary. (see an Authorized Toro Service Distributor).

Note: The following machine components are considered parts subject to consumption through use unless found defective and are not covered by the Warranty associated with this machine.

Have an Authorized Toro Service Distributor check following internal-pump components for damage:

- Pump diaphragm
- Pump check-valve assemblies

Replace any components if necessary.

Adjusting the Actuators

The following procedure can be used to adjust the length of the actuator rods.

1. Extend the booms to the spray position.
2. Remove the cotter pin from the pivot pin (Figure 93).

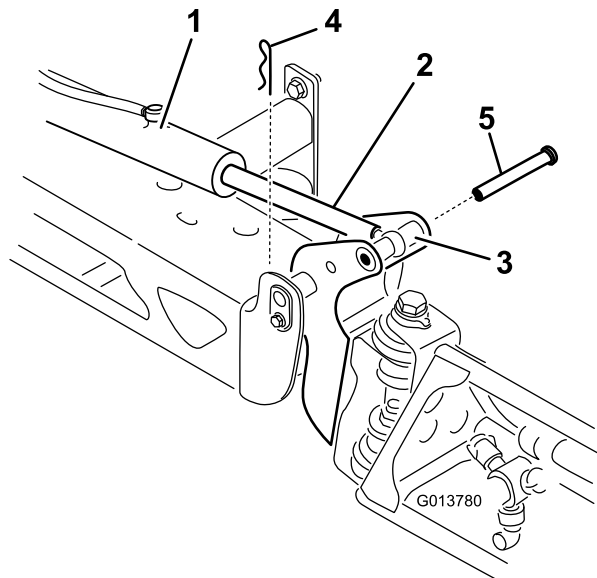

Figure 93

1. Actuator
2. Actuator rod
3. Boom-pivot-pin housing
4. Cotter
5. Pin

3. Lift up on the boom, remove the pin, and slowly lower the boom to the ground (Figure 93).

Note: Inspect the pin for any damage, and replace if necessary.

4. Use a wrench on the flat sides of the actuator rod to immobilize it, then loosen the jam nut to manipulate the eyelet rod (Figure 94).

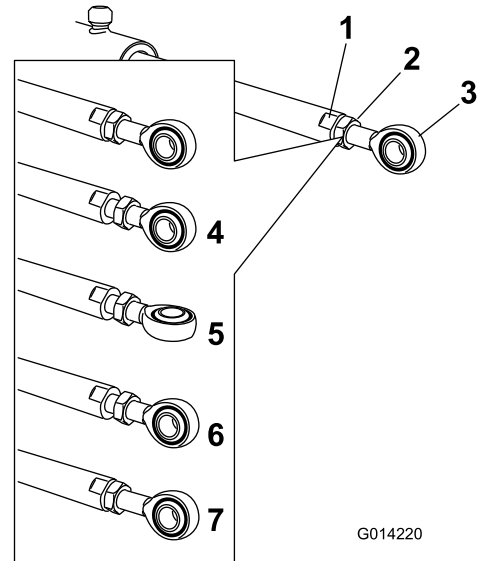

Figure 94

1. Flat side on the actuator rod
 2. Jam nut
 3. Eyelet
 4. Jam nut (loosened)
 5. Eyelet (adjusted)
 6. Eyelet position for reassembly
 7. Jam nut tightened to lock new position
-
5. Turn the eyelet rod in the actuator rod to shorten or lengthen the extended actuator to the desired position (Figure 94).
- Note:** Turn the eyelet rod in half or complete revolutions to allow the assembly of the rod to the boom.
6. With the eyelet rod in the desired position, tighten the jam nut to secure the actuator and eyelet rod.
 7. Raise the boom to align the pivot with the actuator rod.
 8. While holding the boom, insert the pin through the boom pivot and actuator rod (Figure 93).
 9. With the pin in place, release the boom and secure the pin with the cotter removed previously.
 10. Repeat the procedure for each actuator rod bearing if necessary.

Inspecting the Pivot Bushings

Service Interval: Every 400 hours/Yearly (whichever comes first)

1. Position the sprayer on a level surface, set the parking brake, stop the pump, stop the engine, and remove the key from the starter switch.
2. Extend the booms to the spray position and support the booms using stands or straps from a lift.
3. With the weight of the boom supported, remove the bolt and nut securing the pivot pin to the boom assembly ([Figure 95](#)).

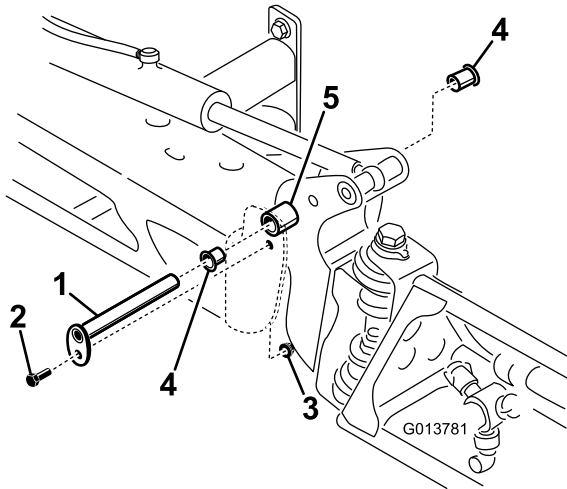

Figure 95

G013781

- | | |
|--------------|------------------|
| 1. Pivot pin | 4. Nylon bushing |
| 2. Bolt | 5. Pivot bracket |
| 3. Nut | |

4. Remove the pivot pin ([Figure 95](#)).
5. Remove the boom and pivot-bracket assembly from the center frame to access the nylon bushings.
6. Remove and inspect the nylon bushings from the front and back sides of the pivot bracket ([Figure 95](#)).
Note: Replace any damaged bushings.
7. Place a small amount of oil on the nylon bushings and install them into the pivot bracket.
8. Install the boom and pivot-bracket assembly into the center frame, aligning the openings ([Figure 95](#)).
9. Install the pivot pin and secure it with the bolt and nut removed previously.
10. Repeat this procedure for each boom.

Cleaning

Cleaning the Radiator-Cooling Fins

Service Interval: Every 200 hours—Clean the radiator fins.

Important: Do not spray water into a hot engine compartment, as it may damage the engine.

1. Position the sprayer on a level surface, set the parking brake, stop the pump, stop the engine, and remove the key from the starter switch.
2. Tilt the driver and passenger seats forward and align the prop rod into the detent in the prop-rod-guide slot.
3. Allow the cooling system to cool.
4. Remove the seat-base-access cover; refer to [Removing the Seat-Base-Access Panel \(page 51\)](#).
5. Using a soft brush and low-pressure compressed air, clean the fins of the radiator.
Note: Clean the radiator fins more often if needed. Check all coolant hoses and replace any that are worn, leaking, or damaged.
6. Lower the driver and passenger seats.
7. Install the seat-base-access cover; refer to [Installing the Seat-Base-Access Panel \(page 51\)](#).

Cleaning the Agitation and Section Valves

- To clean the agitation valve; refer to the following sections:
 1. [Removing the Valve Actuator \(page 76\)](#)
 2. [Removing the Agitation-Manifold Valve \(page 76\)](#)
 3. [Cleaning the Manifold Valve \(page 78\)](#)
 4. [Assembling the Manifold Valve \(page 79\)](#)
 5. [Installing the Agitation-Manifold Valve \(page 80\)](#)
 6. [Installing the Valve Actuator \(page 81\)](#)
- To clean the 3 section valves; refer to the following sections:
 1. [Removing the Valve Actuator \(page 76\)](#)
 2. [Removing the Section-Manifold Valve \(page 77\)](#)
 3. [Cleaning the Manifold Valve \(page 78\)](#)
 4. [Assembling the Manifold Valve \(page 79\)](#)

5. [Installing the Section-Manifold Valve \(page 80\)](#)
6. [Installing the Valve Actuator \(page 81\)](#)

Removing the Valve Actuator

1. Position the sprayer on a level surface, set the parking brake, stop the pump, stop the engine, and remove the key from the starter switch.
2. Remove the retainer that secures the actuator to the manifold valve for the section valve or agitation valve ([Figure 96](#)).

Note: Squeeze the 2 legs of the retainer together while pushing it down.

Note: Retain the actuator and retainer for installation in [Installing the Valve Actuator \(page 81\)](#).

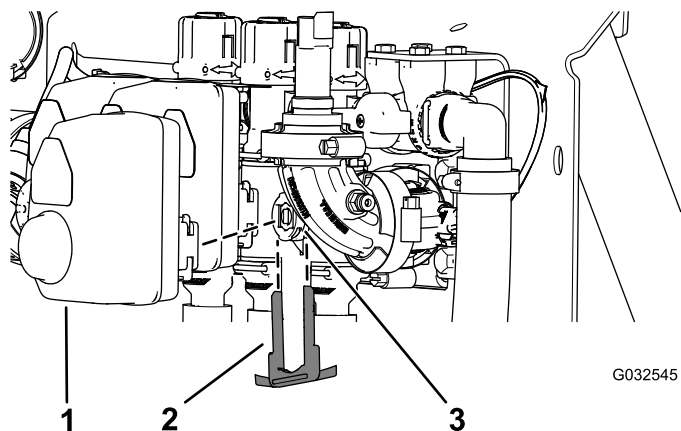

Figure 96

Section Valve Actuator Shown (the agitation-valve actuator is similar)

1. Actuator (section valve)
2. Retainer
3. Stem port

3. Remove the actuator from the manifold valve.

Removing the Agitation-Manifold Valve

1. Remove the clamps, gaskets, quick connect, and quick-connect pin that secure the manifold for the agitation valve to the agitation-bypass valve, pressure-filter head, reducer coupling, and adapter fitting (agitation-throttle valve) as shown in [Figure 97](#).

Note: Retain the clamps, gaskets, quick connect, and quick-connect pin for installation in [Installing the Agitation-Manifold Valve \(page 80\)](#).

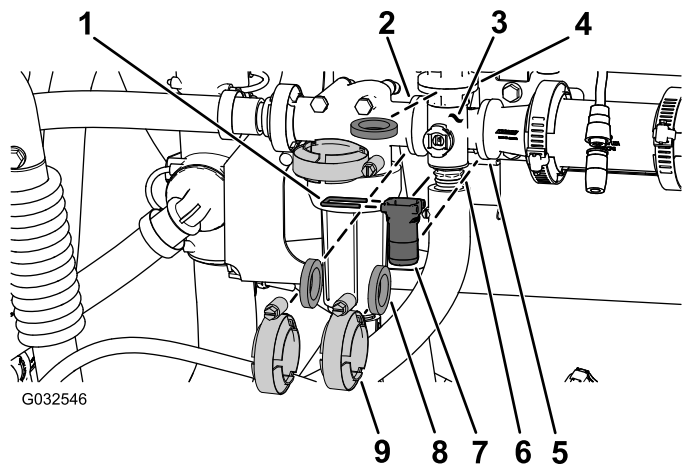

Figure 97
Agitation Valve

- | | |
|------------------------------------|--|
| 1. Quick-connect pin | 6. Flange (adapter fitting—agitation-throttle valve) |
| 2. Flange (pressure-filter head) | 7. Quick connect |
| 3. Manifold (agitation valve) | 8. Gasket |
| 4. Flange (agitation-bypass valve) | 9. Flange clamp |
| 5. Flange (reducer coupling) | |

2. Remove the agitation-valve manifold from the machine ([Figure 98](#)).

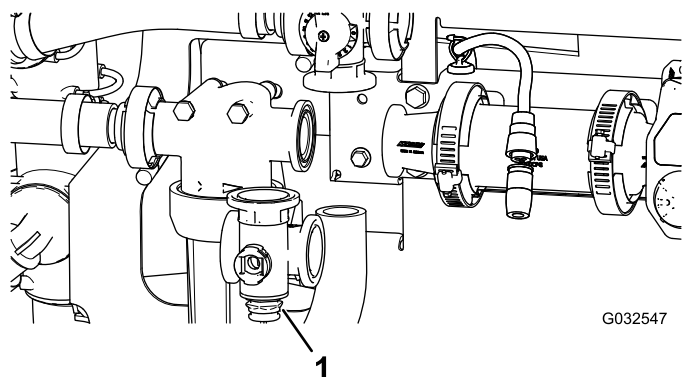

Figure 98

1. Agitation-valve manifold

Removing the Section-Manifold Valve

1. Remove the clamps and gaskets that secure the manifold for the section valve to the adjacent section valve (if left, section valve and the reducer coupling) as shown in [Figure 99](#).

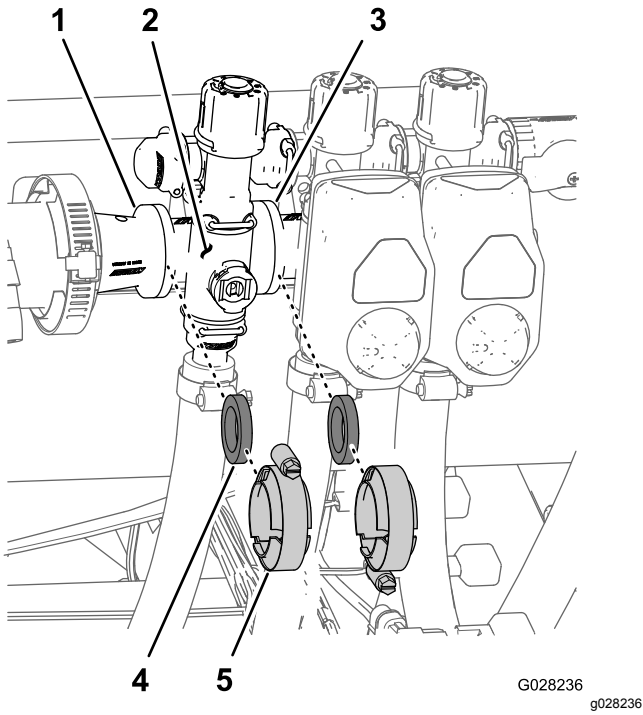

Figure 99

- | | |
|------------------------------------|-----------------|
| 1. Flange (reducer coupling) | 4. Gasket |
| 2. Manifold (section valve) | 5. Flange clamp |
| 3. Flange (adjacent section valve) | |

2. Remove the retainer that secures the section-valve manifold to the bypass fitting ([Figure 100](#)).

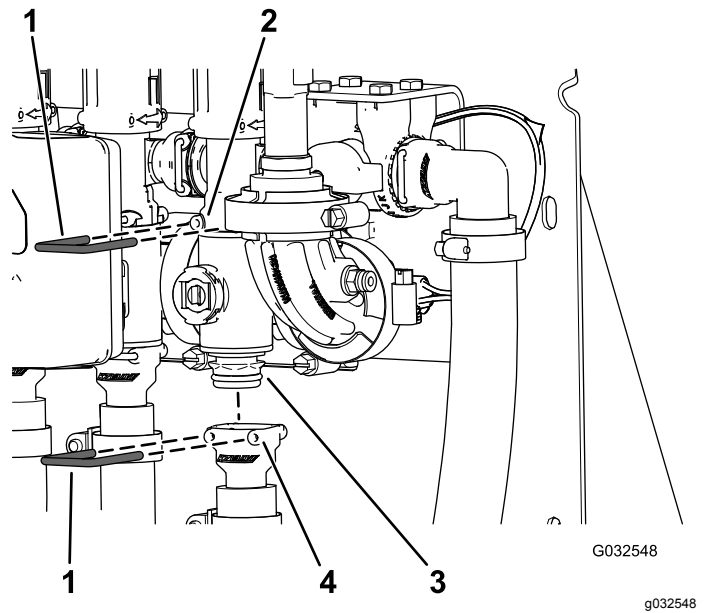

Figure 100

- | | |
|----------------------------|----------------------------|
| 1. Retainer | 3. Manifold-valve assembly |
| 2. Socket (bypass fitting) | 4. Socket (outlet fitting) |

3. Remove the section-valve manifold from the machine ([Figure 101](#)).

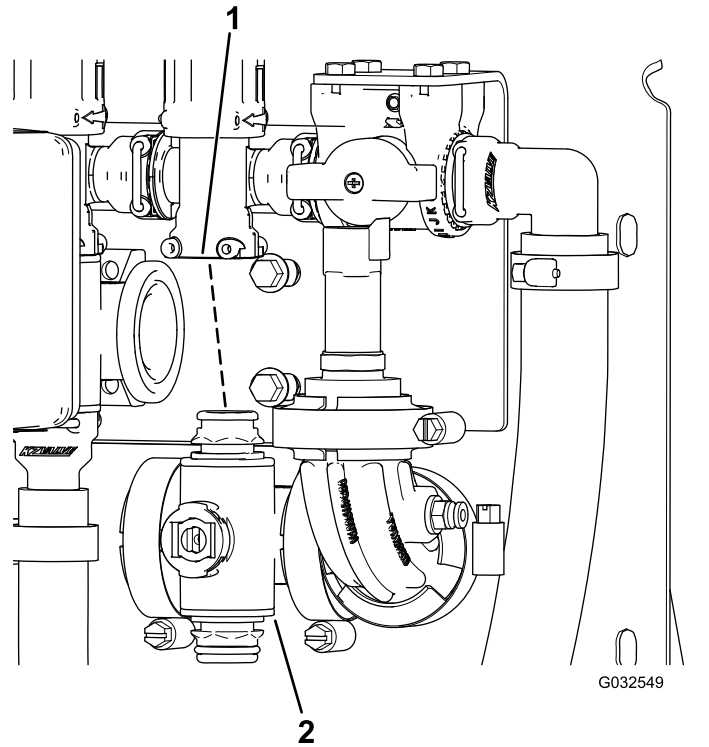

Figure 101

- | | |
|-------------------|---------------------------|
| 1. Bypass fitting | 2. Section-valve manifold |
|-------------------|---------------------------|

Cleaning the Manifold Valve

1. Position the valve stem so that it is in the closed position (B of Figure 102).

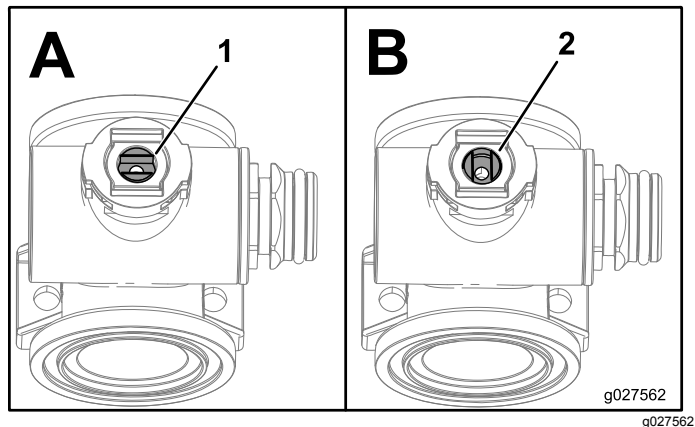

Figure 102

1. Valve open
2. Valve closed

2. Remove the end-cap-fitting assembly and quick connect from each end of the manifold body (Figure 103 and Figure 104).

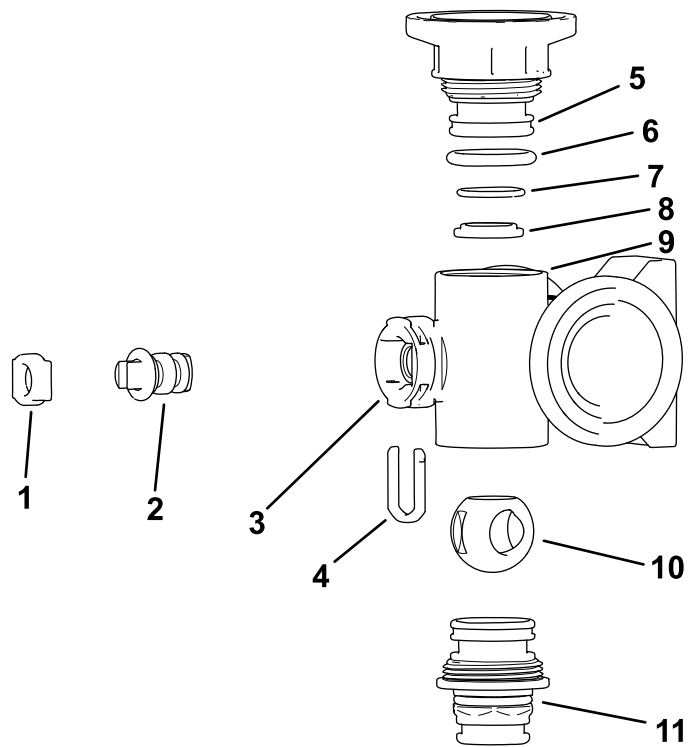
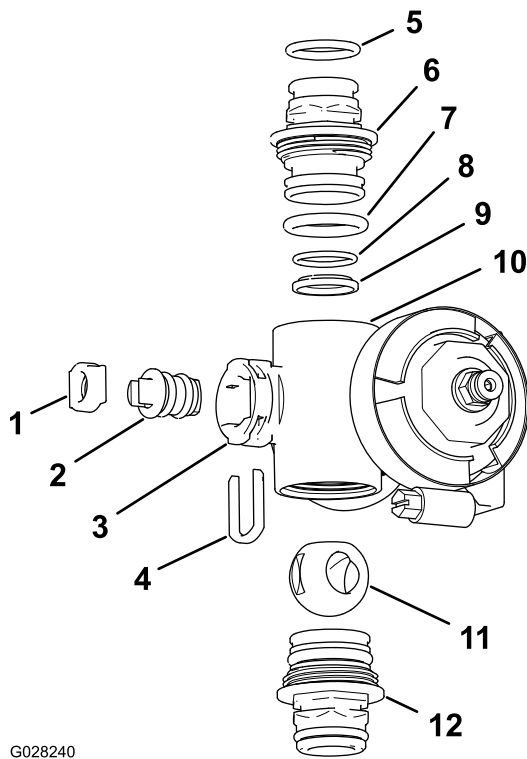

Figure 103
Agitation-Valve Manifold

- | | |
|---|---|
| 1. Stem retainer | 7. Back seating O-ring (0.676 inch/0.07 inch) |
| 2. Valve stem | 8. Valve-seat ring |
| 3. Stem port | 9. Manifold body |
| 4. Stem retainer | 10. Ball valve |
| 5. Endcap fitting | 11. Quick connect |
| 6. Endcap seal O-ring (0.796 inch/0.139 inch) | |



G028240

g028240

Figure 104
Section-Valve Manifold

- | | |
|--|---|
| 1. Valve-stem seat | 7. End cap O-ring (0.796 inch / 0.139 inch) |
| 2. Valve-stem assembly | 8. Back seating O-ring (0.676 inch / 0.07 inch) |
| 3. Stem port | 9. Ball seat |
| 4. Stem retainer | 10. Manifold body |
| 5. Outlet fitting O-ring (0.737 inch / 0.103 inch) | 11. Ball valve |
| 6. End-cap fitting | 12. End-cap-fitting assembly |

- Turn the valve stem so that the ball is in the open position (A of [Figure 102](#)).

Note: The valve stem should be parallel with the valve flow and the ball should slide out.

- Remove the stem retainer from the slots in the stem port in the manifold ([Figure 103](#) and [Figure 104](#)).
- Remove the stem retainer and valve-stem seat from the manifold ([Figure 103](#) and [Figure 104](#)).
- Reach into the manifold body and remove the valve-stem assembly ([Figure 103](#) and [Figure 104](#)).
- Clean the inside of the manifold and exterior of the ball valve, valve-stem assembly, stem capture, and end fittings.

Assembling the Manifold Valve

- Check the condition of the outlet fitting O-rings (**section-valve manifold only**), end cap O-rings, back seating O-rings, ball seat for damage or wear ([Figure 103](#) and [Figure 104](#)).
Note: Replace any damaged or worn O-rings or seats.
- Apply grease to the valve stem and insert it into the valve-stem seat ([Figure 103](#) and [Figure 104](#)).
- Install the valve stem and seat it into the manifold and secure the stem and seat with the stem retainer ([Figure 103](#) and [Figure 104](#)).
- Ensure that the back seating O-ring and the ball seat are aligned and seated into the end-cap fitting ([Figure 103](#) and [Figure 104](#)).
- Install the quick connect onto the manifold body until the flange of the end-cap fitting touches the manifold body, then turn the end-cap fitting an additional 1/8 to 1/4 turn ([Figure 103](#) and [Figure 104](#)).

Note: Use caution to prevent damaging the end of the fitting.

- Insert the ball into the valve body ([Figure 105](#)).

Note: The valve stem should fit inside the ball-drive slot. If the valve stem does not fit, adjust the position of the ball ([Figure 105](#)).

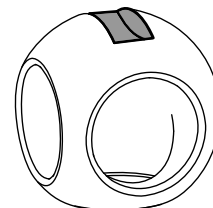
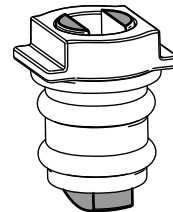

g027565

g027565

Figure 105

- Turn the valve-stem assembly so that the valve is closed (B of [Figure 102](#)).
- Repeat steps 4 and 5 for the other end-cap-fitting assembly.

Installing the Agitation-Manifold Valve

1. Align the flange of the agitation-bypass valve, a gasket, and the end-cap-fitting flange of the agitation-valve manifold (A of Figure 106).

Note: If needed, loosen the mounting hardware for the pressure filter head as needed to provide clearance.

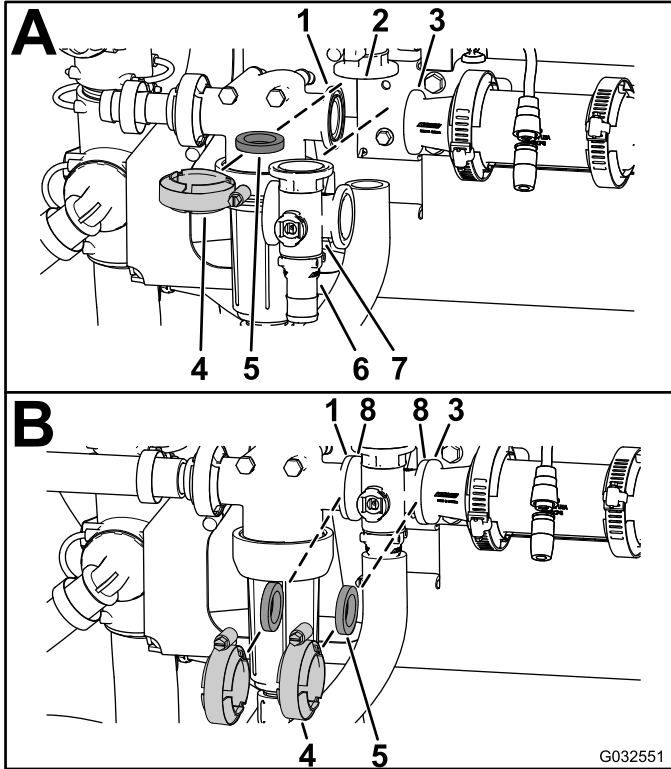

Figure 106

- | | |
|------------------------------------|--------------------------------------|
| 1. Flange (pressure-filter head) | 5. Gasket |
| 2. Flange (agitation-bypass valve) | 6. Quick connect |
| 3. Flange (reducer coupling) | 7. Manifold (agitation valve) |
| 4. Flange clamp | 8. Flange (manifold—agitation valve) |

2. Assemble the agitation-bypass valve, gasket, and agitation-valve manifold with a clamp tightened hand tight (A of Figure 106).
3. Secure the quick connect to the bypass fitting by inserting a retainer into the socket of the bypass fitting (A of Figure 106).
4. Align a gasket between the flanges of the pressure-filter head and the agitation-valve manifold (B of Figure 106).
5. Assemble the pressure-filter head, gasket, and agitation-valve manifold with a clamp tightened hand tight (B of Figure 106).

6. Align a gasket between the flanges of the agitation-valve manifold and the reducer coupling (B of Figure 106).
7. Assemble the agitation-valve manifold, gasket, and reducer coupling with a clamp tightened hand tight (B of Figure 106).
8. If you loosened the mounting hardware for the pressure-filter head, tighten the nut and bolt to 1978 to 2542 N·cm (175 to 225 in-lb).

Installing the Section-Manifold Valve

1. Insert the upper end-cap fitting of the manifold valve into the bypass fitting (A of Figure 107).

Note: If needed, loosen the mounting hardware for the bypass valve as needed to provide clearance.

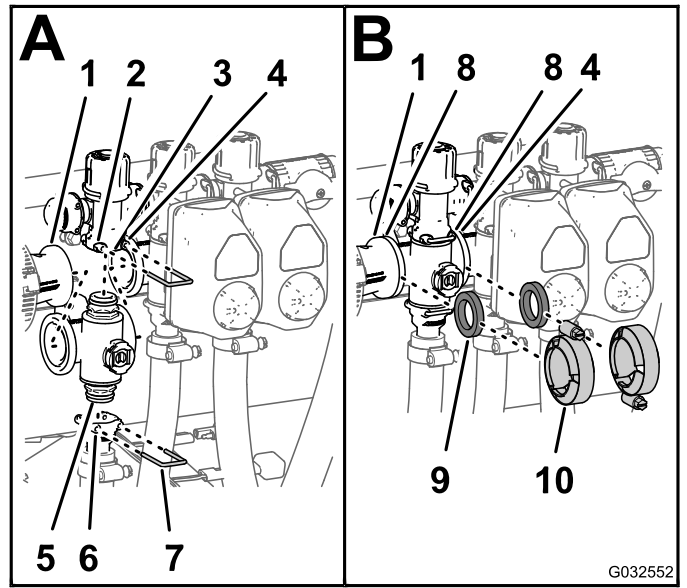

Figure 107

- | | |
|---|------------------------------------|
| 1. Flange (reducer coupling) | 6. Socket (outlet fitting) |
| 2. Socket (bypass fitting) | 7. Retainer |
| 3. Bypass valve | 8. Flange (manifold—section valve) |
| 4. Flange (adjacent manifold—agitation valve) | 9. Gasket |
| 5. End-cap fitting (manifold-valve assembly) | 10. Flange clamp |

2. Secure the end-cap fitting to the bypass fitting by inserting a retainer into the socket of the bypass fitting (A of Figure 107).
3. Assemble the outlet fitting onto the lower end-cap fitting of the manifold valve (A of Figure 107).

4. Secure the end-cap fitting to the outlet fitting by inserting a retainer into the socket of the outlet fitting (A of [Figure 107](#)).
5. Align a gasket between the flanges of the reducer coupling and the section-valve manifold (B of [Figure 107](#)).
6. Assemble the reducer coupling, gasket, and section-valve manifold with a clamp tightened hand tight (B of [Figure 107](#)).
7. If installing the 2 left section valves, align a gasket between the flanges of the 2 adjacent section-valve manifolds (B of [Figure 107](#)).
8. Assemble the 2 adjacent section-valve manifolds and gasket with a clamp tightened hand tight (B of [Figure 107](#)).
9. If you loosened the mounting hardware for the bypass valve, tighten the nut and bolt to 1,017 to 1,243 N·cm (90 to 110 in-lb).

Installing the Valve Actuator

1. Align the actuator to the manifold valve ([Figure 96](#)).
2. Secure the actuator and valve with the retainer that you removed in step 2 of [Removing the Section-Manifold Valve \(page 77\)](#).

Storage

1. Position the sprayer on a level surface, set the parking brake, stop the pump, stop the engine, and remove the key from the starter switch.
2. Clean the dirt and grime from the entire machine, including the outside of the engine's cylinder-head fins and blower housing.

Important: You can wash the machine with mild detergent and water. **Do not use high-pressure water to wash the machine. Pressure washing may damage the electrical system or wash away necessary grease at friction points. Avoid excessive use of water, especially near the control panel, lights, engine, and the battery.**

3. Condition the sprayer system as follows:
 - A. Drain the fresh-water tank.
 - B. Drain the spray system as completely as possible.
 - C. Prepare rust inhibiting, non-alcohol based, RV antifreeze solution per the manufacturer's instructions.
 - D. Add the RV antifreeze solution to the fresh-water tank and the sprayer tank.
 - E. Run the sprayer pump for a few minutes to circulate the RV antifreeze throughout the sprayer system and any installed spray accessories.
 - F. Turn the master-boom-switch to the ON position and spray out the nozzle until the RV anti-freeze is visible, then turn the master-boom-switch to the OFF position.
 - G. Drain the fresh-water tank and spray system as completely as possible.
4. Use the boom-lift switches to raise the booms. Raise the booms until they have moved completely into boom-transport cradle forming the "X" transport position and the boom cylinders are fully retracted.

Note: Make sure that the boom cylinders are fully retracted to prevent actuator rod damage.

5. Perform the following maintenance steps for short-term or long-term storage
 - **Short-term storage** (less than 30 days), clean the sprayer system; refer to [Cleaning the Sprayer \(page 42\)](#).
 - **Long-term storage** (longer than 30 days), perform the following:
 - A. Clean the agitation valve and the 3 section valves; refer to [Cleaning the Manifold Valve \(page 78\)](#).

- B. Check the brakes; refer to [Checking the Brakes \(page 36\)](#).
- C. Service the air cleaner; refer to [Checking the Air Cleaner \(page 54\)](#).
- D. Grease the sprayer; refer to [Greasing the Sprayer \(page 52\)](#).
- E. Change the engine-oil filter and oil; refer to [Changing the Engine Oil \(page 57\)](#) and [Changing the Engine-Oil Filter \(page 57\)](#).
- F. Check the tire pressure; refer to [Checking the Tire Pressure \(page 36\)](#).
- G. Prepare the fuel system as follows:
 - i. Start the engine and run it at idle speed for approximately 2 minutes.
 - ii. Shut off the engine.
 - iii. Flush the fuel tank with fresh, clean fuel.
 - iv. Secure all the fuel-system fittings.
- H. Use the starter to crank the engine and distribute the oil inside the cylinder.
- I. Check and tighten all bolts, nuts, and screws.
- J. Check the condition of all spray hoses.
- K. Tighten all hose fittings.
- L. Paint all scratched or bare metal surfaces (paint is available from your Authorized Service Dealer).
- M. Store the machine in a clean, dry storage area.
- N. Remove the battery from the chassis, check the electrolyte level, and charge the battery fully; refer to [Charging the Battery \(page 63\)](#).

Important: The battery must be fully charged to prevent it from freezing and being damaged at temperatures below 32 degrees F (0 degrees C). A fully charged battery maintains its charge for about 50 days at temperatures lower than 4°C (40°F). If the temperatures will be above 4°C (40°F), check the water level in the battery and charge it every 30 days.

- Note:** Do not connect the battery cables to the battery posts during storage.
- O. Remove the key from the starter switch and put the key in a safe place out of the reach of children.
 - P. Cover the machine to protect it and keep it clean.

Troubleshooting

Troubleshooting the Engine and Vehicle

Problem	Possible Cause	Corrective Action
The starter does not rotate the engine.	<ol style="list-style-type: none"> 1. The electrical connections are corroded or loose. 2. A fuse is blown or loose. 3. The battery is discharged. 4. A broken starter or starter solenoid. 5. Seized internal engine components. 	<ol style="list-style-type: none"> 1. Check the electrical connections for good contact. 2. Correct or replace fuse. 3. Charge or replace the battery. 4. Contact your Authorized Service Dealer. 5. Contact your Authorized Service Dealer.
The engine cranks, but does not start.	<ol style="list-style-type: none"> 1. The fuel tank is empty. 2. Dirt, water, or stale fuel is in the fuel system. 3. Clogged fuel line. 4. The kill relay is not energized. 5. The starter switch is broken. 	<ol style="list-style-type: none"> 1. Fill the tank with fresh fuel. 2. Drain and flush the fuel system; add fresh fuel. 3. Clean or replace. 4. Contact your Authorized Service Dealer. 5. Contact your Authorized Service Dealer.
The engine starts, but does not keep running.	<ol style="list-style-type: none"> 1. The fuel-tank vent is restricted. 2. Dirt or water in the fuel system. 3. The fuel filter is clogged. 4. A fuse is blown or loose. 5. The fuel pump is broken. 6. Loose wires or poor connections. 7. The cylinder-head gasket is broken. 	<ol style="list-style-type: none"> 1. Replace the fuel cap. 2. Drain and flush the fuel system; add fresh fuel. 3. Replace the fuel filter. 4. Correct or replace the fuse. 5. Contact your Authorized Service Dealer. 6. Check and tighten wire connections. 7. Contact your Authorized Service Dealer.
The engine runs, but knocks or misses.	<ol style="list-style-type: none"> 1. Dirt, water, or stale fuel is in the fuel system. 2. Loose wires or poor connections. 3. The engine is overheating. 	<ol style="list-style-type: none"> 1. Drain and flush the fuel system; add fresh fuel. 2. Check and tighten wire connections. 3. See "The engine overheats" below.
The engine does not idle.	<ol style="list-style-type: none"> 1. The fuel-tank vent is restricted. 2. Dirt, water, or stale fuel is in the fuel system. 3. The fuel pump is broken. 4. Low compression. 5. The air cleaner element is dirty. 	<ol style="list-style-type: none"> 1. Replace the fuel cap. 2. Drain and flush the fuel system; add fresh fuel. 3. Contact your Authorized Service Dealer. 4. Contact your Authorized Service Dealer. 5. Replace the air-filter element.
The engine overheats.	<ol style="list-style-type: none"> 1. The crankcase-oil level is incorrect. 2. The coolant level is low. 3. Excessive loading. 4. The air-intake screens are dirty. 5. The cooling fins and air passages under the engine blower housing and/or the rotating air-intake screen are plugged. 	<ol style="list-style-type: none"> 1. Fill or drain to the Full mark. 2. Check the coolant level and replenish it as needed. 3. Reduce load; use lower ground speed. 4. Clean with the air-intake screens with every use. 5. Clean the cooling fins and air passages with every use.

Problem	Possible Cause	Corrective Action
The engine loses power.	<ol style="list-style-type: none"> 1. The crankcase-oil level is incorrect. 2. The air-cleaner element is dirty. 3. Dirt, water, or stale fuel is in the fuel system. 4. The engine is overheated. 5. The vent hole in the fuel-tank-vent fitting is plugged. 6. Low compression. 	<ol style="list-style-type: none"> 1. Fill or drain to the Full mark. 2. Replace the air-cleaner element. 3. Drain and flush the fuel system; add fresh fuel. 4. See Engine Overheats. 5. Replace the fuel cap. 6. Contact your Authorized Service Dealer.
There is abnormal vibration or noise.	<ol style="list-style-type: none"> 1. The engine-mounting bolts are loose. 2. There is a problem with the engine. 	<ol style="list-style-type: none"> 1. Tighten the engine-mounting bolts. 2. Contact your Authorized Service Dealer.
The machine does not operate or is sluggish in either direction because the engine bogs down or stalls.	<ol style="list-style-type: none"> 1. The parking brake is set. 	<ol style="list-style-type: none"> 1. Release the parking brake.
The machine does not operate in either direction.	<ol style="list-style-type: none"> 1. The parking brake was not released or the parking brake is not releasing. 2. The transmission is broken. 3. The control linkage needs adjustment or replacement. 4. The drive shaft or wheel-hub key is damaged. 	<ol style="list-style-type: none"> 1. Release the parking brake or check the linkage. 2. Contact your Authorized Service Dealer. 3. Contact your Authorized Service Dealer. 4. Contact your Authorized Service Dealer.

Troubleshooting the Spray System

Problem	Possible Cause	Corrective Action
A boom section does not spray.	<ol style="list-style-type: none"> 1. The electrical connection on the boom valve is dirty or disconnected. 2. Blown fuse. 3. Pinched hose. 4. A boom-bypass valve is improperly adjusted. 5. Damaged boom valve. 6. Damaged electrical system. 	<ol style="list-style-type: none"> 1. Turn the valve off manually. Disconnect the electrical connector on the valve and clean all leads, then reconnect it. 2. Check the fuses and replace them as necessary. 3. Repair or replace the hose. 4. Adjust the boom-bypass valves. 5. Contact your Authorized Service Dealer. 6. Contact your Authorized Service Dealer.
A boom section does not turn off.	<ol style="list-style-type: none"> 1. The boom-section valve is damaged. 	<ol style="list-style-type: none"> 1. Disassemble the boom-section valve; refer to the section Cleaning the Sprayer Valves. Inspect all of the parts and replace any that are damaged.
A boom valve is leaking.	<ol style="list-style-type: none"> 1. A seal is worn or damaged. 	<ol style="list-style-type: none"> 1. Disassemble the valve and replace the seals using the Valve Repair Kit; contact your Authorized Service Dealer.
The pressure drops when you turn on a boom.	<ol style="list-style-type: none"> 1. The boom-bypass valve is improperly adjusted. 2. There is an obstruction in the boom-valve body. 3. A nozzle filter is damaged or clogged. 	<ol style="list-style-type: none"> 1. Adjust the boom-bypass valve. 2. Remove the inlet and outlet connections to the boom valve and remove any obstructions. 3. Remove and inspect all nozzles.

Problem	Possible Cause	Corrective Action
A boom actuator is not operating properly.	<ol style="list-style-type: none"> 1. A thermal breaker in the fuse block responsible for powering the actuator has tripped due to overheating. 2. A thermal breaker in the boom actuator responsible for powering the actuator has tripped or malfunctioned. 	<ol style="list-style-type: none"> 1. Wait for the system to cool down before resuming operation. If the thermal breakers trip repeatedly, contact your Authorized Service Dealer. 2. Contact your Authorized Service Dealer.

Notes:

Notes:



The Toro Warranty

A Two-Year Limited Warranty

Conditions and Products Covered

The Toro Company and its affiliate, Toro Warranty Company, pursuant to an agreement between them, jointly warrant your Toro Commercial product ("Product") to be free from defects in materials or workmanship for two years or 1500 operational hours*, whichever occurs first. This warranty is applicable to all products with the exception of Aerators (refer to separate warranty statements for these products). Where a warrantable condition exists, we will repair the Product at no cost to you including diagnostics, labor, parts, and transportation. This warranty begins on the date the Product is delivered to the original retail purchaser.

* Product equipped with an hour meter.

Instructions for Obtaining Warranty Service

You are responsible for notifying the Commercial Products Distributor or Authorized Commercial Products Dealer from whom you purchased the Product as soon as you believe a warrantable condition exists. If you need help locating a Commercial Products Distributor or Authorized Dealer, or if you have questions regarding your warranty rights or responsibilities, you may contact us at:

Toro Commercial Products Service Department
Toro Warranty Company
8111 Lyndale Avenue South
Bloomington, MN 55420-1196
952-888-8801 or 800-952-2740
E-mail: commercial.warranty@toro.com

Owner Responsibilities

As the Product owner, you are responsible for required maintenance and adjustments stated in your *Operator's Manual*. Failure to perform required maintenance and adjustments can be grounds for disallowing a warranty claim.

Items and Conditions Not Covered

Not all product failures or malfunctions that occur during the warranty period are defects in materials or workmanship. This warranty does not cover the following:

- Product failures which result from the use of non-Toro replacement parts, or from installation and use of add-on, or modified non-Toro branded accessories and products. A separate warranty may be provided by the manufacturer of these items.
- Product failures which result from failure to perform recommended maintenance and/or adjustments. Failure to properly maintain your Toro product per the Recommended Maintenance listed in the *Operator's Manual* can result in claims for warranty being denied.
- Product failures which result from operating the Product in an abusive, negligent, or reckless manner.
- Parts subject to consumption through use unless found to be defective. Examples of parts which are consumed, or used up, during normal Product operation include, but are not limited to, brake pads and linings, clutch linings, blades, reels, rollers and bearings (sealed or greasable), bed knives, spark plugs, castor wheels and bearings, tires, filters, belts, and certain sprayer components such as diaphragms, nozzles, and check valves, etc.
- Failures caused by outside influence. Conditions considered to be outside influence include, but are not limited to, weather, storage practices, contamination, use of unapproved fuels, coolants, lubricants, additives, fertilizers, water, or chemicals, etc.
- Failure or performance issues due to the use of fuels (e.g. gasoline, diesel, or biodiesel) that do not conform to their respective industry standards.

Countries Other than the United States or Canada

Customers who have purchased Toro products exported from the United States or Canada should contact their Toro Distributor (Dealer) to obtain guarantee policies for your country, province, or state. If for any reason you are dissatisfied with your Distributor's service or have difficulty obtaining guarantee information, contact the Toro importer.

- Normal noise, vibration, wear and tear, and deterioration.
- Normal "wear and tear" includes, but is not limited to, damage to seats due to wear or abrasion, worn painted surfaces, scratched decals or windows, etc.

Parts

Parts scheduled for replacement as required maintenance are warranted for the period of time up to the scheduled replacement time for that part. Parts replaced under this warranty are covered for the duration of the original product warranty and become the property of Toro. Toro will make the final decision whether to repair any existing part or assembly or replace it. Toro may use remanufactured parts for warranty repairs.

Deep Cycle and Lithium-Ion Battery Warranty:

Deep cycle and Lithium-Ion batteries have a specified total number of kilowatt-hours they can deliver during their lifetime. Operating, recharging, and maintenance techniques can extend or reduce total battery life. As the batteries in this product are consumed, the amount of useful work between charging intervals will slowly decrease until the battery is completely worn out. Replacement of worn out batteries, due to normal consumption, is the responsibility of the product owner. Battery replacement may be required during the normal product warranty period at owner's expense. Note: (Lithium-Ion battery only): A Lithium-Ion battery has a part only prorated warranty beginning year 3 through year 5 based on the time in service and kilowatt hours used. Refer to the *Operator's Manual* for additional information.

Maintenance is at Owner's Expense

Engine tune-up, lubrication, cleaning and polishing, replacement of filters, coolant, and completing recommended maintenance are some of the normal services Toro products require that are at the owner's expense.

General Conditions

Repair by an Authorized Toro Distributor or Dealer is your sole remedy under this warranty.

Neither The Toro Company nor Toro Warranty Company is liable for indirect, incidental or consequential damages in connection with the use of the Toro Products covered by this warranty, including any cost or expense of providing substitute equipment or service during reasonable periods of malfunction or non-use pending completion of repairs under this warranty. Except for the Emissions warranty referenced below, if applicable, there is no other express warranty. All implied warranties of merchantability and fitness for use are limited to the duration of this express warranty.

Some states do not allow exclusions of incidental or consequential damages, or limitations on how long an implied warranty lasts, so the above exclusions and limitations may not apply to you. This warranty gives you specific legal rights, and you may also have other rights which vary from state to state.

Note regarding engine warranty:

The Emissions Control System on your Product may be covered by a separate warranty meeting requirements established by the U.S. Environmental Protection Agency (EPA) and/or the California Air Resources Board (CARB). The hour limitations set forth above do not apply to the Emissions Control System Warranty. Refer to the Engine Emission Control Warranty Statement supplied with your product or contained in the engine manufacturer's documentation for details.