



Part No. 56-6090

**INSTALLATION
INSTRUCTIONS**
ROLLER SCRAPER KIT

(Reelmaster 450 D)

1. Place mower on a level surface.
2. Loosely mount right and left roller scraper brackets to roller scraper with 5/16 - 18 x 3/4" lg. capscrews, lockwashers and flatwashers. Position brackets as shown in Fig.1.
3. Mount scraper and brackets to rear of roller
- brackets with 5/16 - 18 x 5/8" lg. capscrews and lockwashers (Fig.1).
4. Adjust scraper edge to clear roller by 1/16" - 1/8" all across roller.
5. Make sure scraper is parallel to roller and tighten all fasteners.

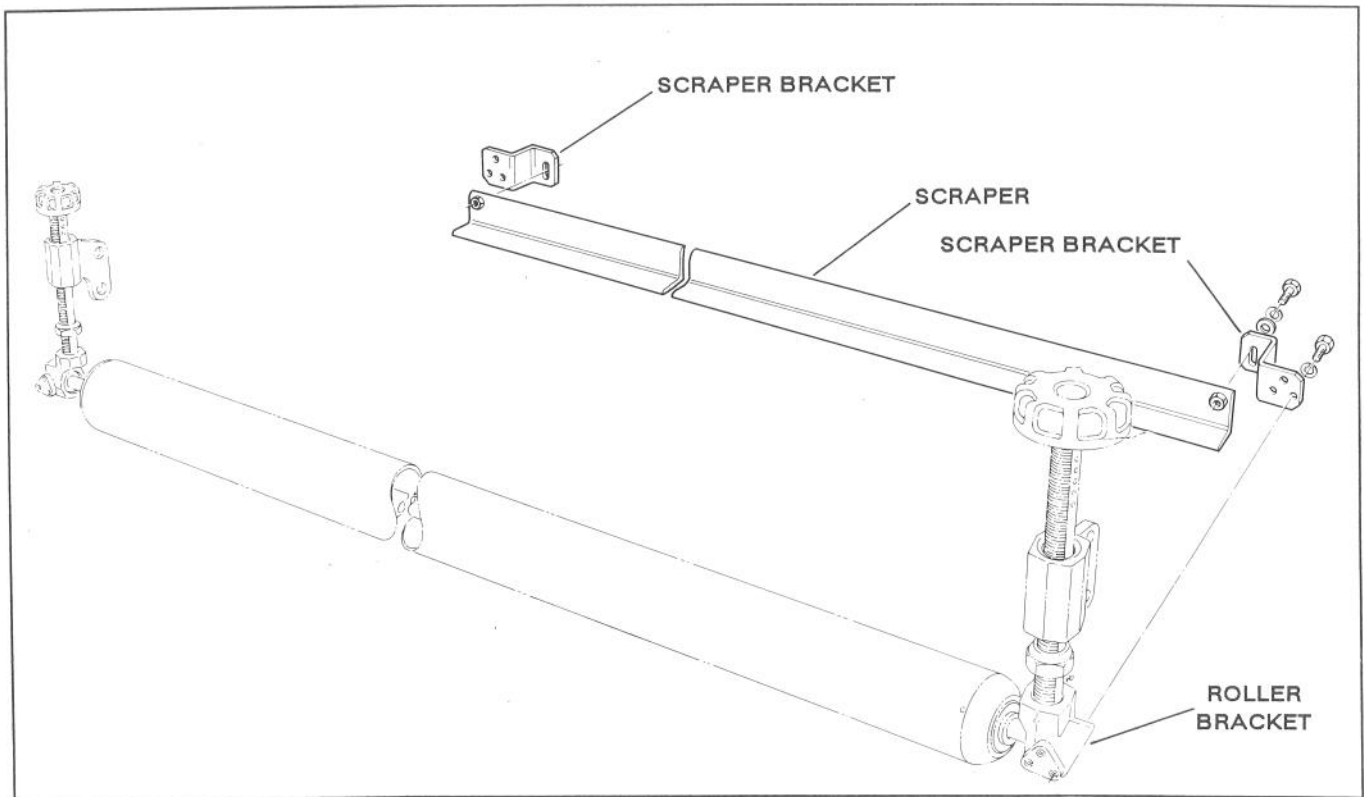

Figure 1