



Count on it.

Operator's Manual

**Z Master® Professional 5000 or
6000 Series Riding Mower
with 48in, 52in, 60in, or 72in TURBO FORCE®
Mower**

Model No. 72904—Serial No. 400000000 and Up

Model No. 72906—Serial No. 400000000 and Up

Model No. 72918—Serial No. 400000000 and Up

Model No. 72926—Serial No. 400000000 and Up

Model No. 72928—Serial No. 400000000 and Up

Model No. 72930—Serial No. 400000000 and Up

Model No. 72943—Serial No. 400000000 and Up

Model No. 72945—Serial No. 400000000 and Up

Model No. 72951—Serial No. 400000000 and Up

Model No. 72955—Serial No. 400000000 and Up



It is a violation of California Public Resource Code Section 4442 or 4443 to use or operate the engine on any forest-covered, brush-covered, or grass-covered land unless the engine is equipped with a spark arrester, as defined in Section 4442, maintained in effective working order or the engine is constructed, equipped, and maintained for the prevention of fire.

Gross or Net Torque: The gross or net torque of this engine was laboratory rated by the engine manufacturer in accordance with the Society of Automotive Engineers (SAE) J1940 or J2723. As configured to meet safety, emission, and operating requirements, the actual engine torque on this class of mower will be significantly lower. Please refer to the engine manufacturer's information included with the machine.

⚠ WARNING

**CALIFORNIA
Proposition 65 Warning**

The engine exhaust from this product contains chemicals known to the State of California to cause cancer, birth defects, or other reproductive harm.

Battery posts, terminals, and related accessories contain lead and lead compounds, chemicals known to the State of California to cause cancer and reproductive harm. Wash hands after handling.

Use of this product may cause exposure to chemicals known to the State of California to cause cancer, birth defects, or other reproductive harm.

Introduction

This rotary-blade, riding lawn mower is intended to be used by professional, hired operators. It is designed primarily for cutting grass on well-maintained lawns on residential or commercial properties. Using this product for purposes other than its intended use could prove dangerous to you and bystanders.

Read this information carefully to learn how to operate and maintain your product properly and to avoid injury and product damage. You are responsible for operating the product properly and safely.

Visit www.Toro.com for product safety and operation training materials, accessory information, help finding a dealer, or to register your product.

Whenever you need service, genuine Toro parts, or additional information, contact an Authorized Service Dealer or Toro Customer Service and have the model and serial numbers of your product ready. **Figure 1** identifies the location of the model and serial numbers on the product. Write the numbers in the space provided.

Important: With your mobile device, you can scan the QR code (if equipped) on the serial number decal to access warranty, parts, and other product information.

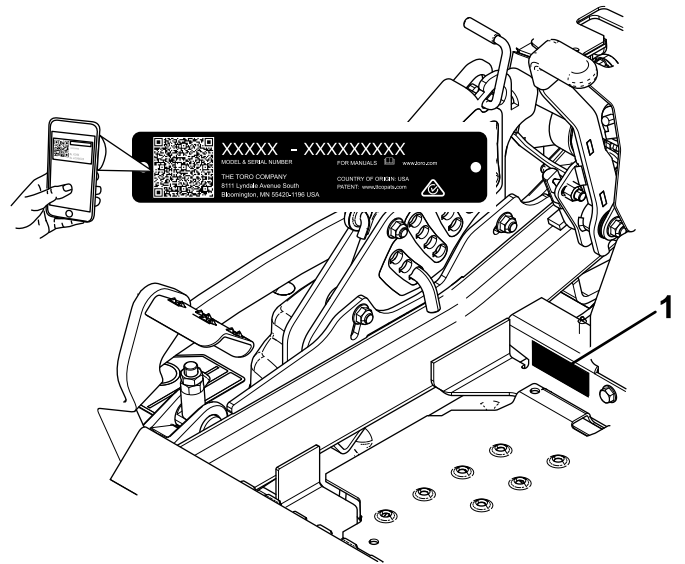

Figure 1

g233771

1. Model and serial number location

Model No. _____

Serial No. _____

This manual uses 2 words to highlight information. **Important** calls attention to special mechanical information and **Note** emphasizes general information worthy of special attention.

Contents

Safety	5	Engine Safety	46
Safety Alert Symbol	5	Servicing the Air Cleaner	46
General Safety	5	Servicing the Engine Oil.....	47
Slope Indicator	6	Servicing the Spark Plug(s)	50
Safety and Instructional Decals	7	Checking the Spark Arrester	51
Product Overview	15	Fuel System Maintenance	51
Controls	15	Servicing the Electronic Fuel-Injection	
Specifications	17	System.....	51
Machines with Side Discharge	17	Replacing the Low-Pressure Fuel	
Machines with Rear Discharge	17	Filter.....	51
Attachments/Accessories	17	Servicing the High-Pressure Fuel Filter.....	52
Before Operation	18	Servicing the Fuel Tank.....	52
Before Operation Safety	18	Electrical System Maintenance	52
Adding Fuel	20	Electrical System Safety	52
Performing Daily Maintenance.....	20	Servicing the Battery.....	52
Breaking in a New Machine	20	Servicing the Fuses	54
Using the Rollover-Protection System		Jump-Starting the Machine.....	54
(ROPS).....	21	Drive System Maintenance	56
Using the Safety-Interlock System	22	Checking the Seat Belt	56
Positioning the Seat.....	23	Checking the Roll-Bar Knobs.....	56
Unlatching the Seat	23	Adjusting the Tracking	57
Changing the Seat Suspension.....	23	Checking the Tire Pressure.....	57
Adjusting the Rear-Shock Assemblies	24	Checking the Wheel Lug Nuts.....	57
During Operation	25	Checking the Wheel-Hub Slotted Nut.....	58
During Operation Safety	25	Adjusting the Caster-Pivot Bearing	58
Entering the Operator's Position	27	Removing the Clutch Shim	58
Operating the Parking Brake.....	28	Cooling System Maintenance	60
Operating the Mower Blade-Control Switch		Cleaning the Engine Screen and Engine-Oil	
(PTO).....	28	Cooler	60
Operating the Throttle.....	28	Cleaning the Engine-Cooling Fins and	
Starting the Engine	29	Shrouds	61
Shutting Off the Engine.....	29	Checking and Cleaning the Hydraulic-Unit	
Using the Motion-Control Levers.....	30	Shrouds	61
Driving the Machine	30	Brake Maintenance	62
Using the Side Discharge	31	Adjusting the Parking Brake.....	62
Adjusting the Height of Cut	32	Belt Maintenance	63
Adjusting the Anti-Scalp Rollers.....	33	Inspecting the Belts	63
Adjusting the Skid(s).....	34	Replacing the Mower Belt for Side-Discharge	
Adjusting the Flow Baffle Knob	34	Mower Decks	63
Positioning the Flow Baffle.....	35	Replacing the Mower Belt for Rear-Discharge	
Operating Tips	36	Mower Decks	64
After Operation	37	Replacing the Hydraulic Pump-Drive	
After Operation Safety	37	Belt.....	65
Using the Fuel-Shutoff Valve.....	37	Controls System Maintenance	66
Using the Drive-Wheel-Release Valves	37	Adjusting the Control-Handle Position	66
Transporting the Machine	38	Adjusting the Motion-Control Linkage	67
Maintenance	40	Adjusting the Motion-Control Damper	68
Maintenance Safety.....	40	Adjusting the Motion-Control Neutral-Lock	
Recommended Maintenance Schedule(s)	41	Pivot.....	68
Lubrication	43	Hydraulic System Maintenance	69
Greasing the Machine.....	43	Hydraulic System Safety.....	69
Lubricating the Mower Deck-Lift Pivots	43	Hydraulic-Fluid Specifications	69
Greasing the Mower Deck	43	Checking the Hydraulic Fluid	69
Greasing the Caster Pivots	45	Changing the Hydraulic Fluid and	
Greasing the Caster-Wheel Hubs	45	Filters.....	70
Engine Maintenance	46	Mower Deck Maintenance.....	71
		Blade Safety	71
		Servicing the Cutting Blades	71

Leveling the Mower Deck.....	74
Removing the Mower Deck.....	77
Replacing the Grass Deflector	78
Cleaning	79
Cleaning under the Mower Deck	79
Cleaning the Suspension System	79
Disposing of Waste	79
Storage	80
Storage Safety.....	80
Cleaning and Storage	80
Troubleshooting	81
Schematics	84

Safety

This machine has been designed in accordance with ANSI standard B71.4-2017.

Safety Alert Symbol

This Safety Alert Symbol (Figure 2) is used both in this manual and on the machine to identify important safety messages which must be followed to avoid accidents.

This symbol means: **ATTENTION! BECOME ALERT! YOUR SAFETY IS INVOLVED!**



Figure 2
Safety Alert Symbol

g000502

The safety alert symbol appears above information which alerts you to unsafe actions or situations and will be followed by the word **DANGER**, **WARNING**, or **CAUTION**.

DANGER: Indicates an imminently hazardous situation which, if not avoided, **Will** result in death or serious injury.

WARNING: Indicates a potentially hazardous situation which, if not avoided, **Could** result in death or serious injury.

CAUTION: Indicates a potentially hazardous situation which, if not avoided, **May** result in minor or moderate injury.

This manual uses two other words to highlight information. **Important** calls attention to special mechanical information and **Note** emphasizes general information worthy of special attention.

General Safety

This machine is capable of amputating hands and feet and of throwing objects. Toro designed and tested this lawn mower to offer reasonably safe service; however, failure to comply with safety instructions may result in injury or death.

- Read, understand, and follow all instructions and warnings in the Operator's Manual and other training material, on the machine, engine, and attachments. All operators and mechanics should be trained. If the operator(s) or mechanic(s) can not read this manual, it is the owner's responsibility to explain this material to them; other languages may be available on our website.
- Only allow trained, responsible, and physically capable operators that are familiar with the safe operation, operator controls, and safety signs and instructions to operate the machine. Never let children or untrained people operate or service the equipment. Local regulations may restrict the age of the operator.
- Always keep the roll bar in the fully raised and locked position and use the seat belt.
- Do not operate the machine near drop-offs, ditches, embankments, water, or other hazards, or on slopes greater than 15 degrees.
- Do not put your hands or feet near moving components of the machine.
- Never operate the machine with damaged guards, shields, or covers. Always have safety shields, guards, switches and other devices in place and in proper working condition.
- Stop the machine, shut off the engine, and remove the key before servicing, fueling, or unclogging the machine.

Slope Indicator

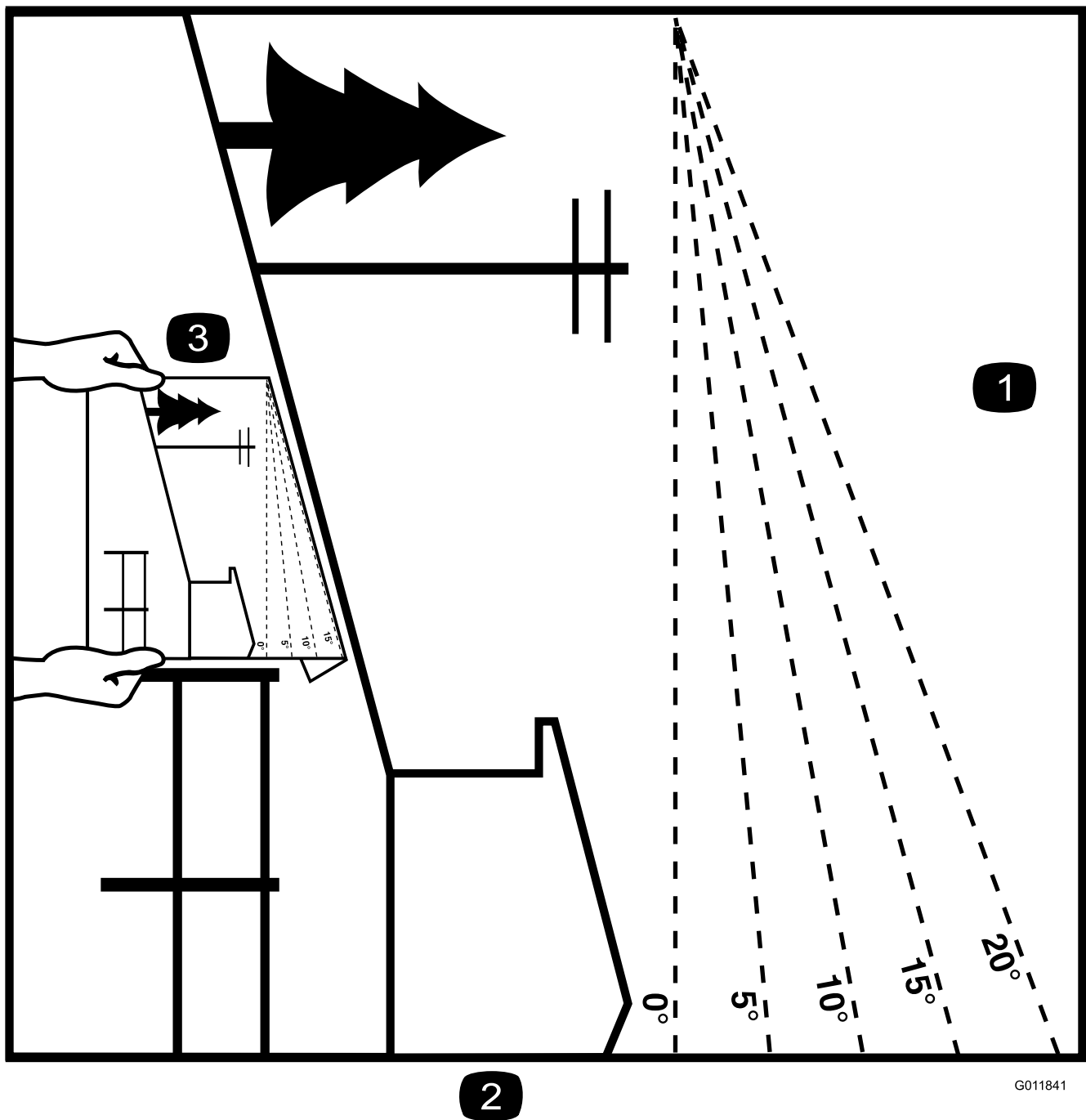

G011841

g011841

Figure 3

You may copy this page for personal use.

1. The maximum slope you can operate the machine on is **15 degrees**. Use the slope chart to determine the degree of slope of hills before operating. **Do not operate this machine on a slope greater than 15 degrees**. Fold along the appropriate line to match the recommended slope.
2. Align this edge with a vertical surface, a tree, building, fence pole, etc.
3. Example of how to compare slope with folded edge

Safety and Instructional Decals



Safety decals and instructions are easily visible to the operator and are located near any area of potential danger. Replace any decal that is damaged or missing.



Battery Symbols

Some or all of these symbols are on your battery.

- | | |
|--|---|
| 1. Explosion hazard | 6. Keep bystanders away from the battery. |
| 2. No fire, open flame, or smoking | 7. Wear eye protection; explosive gases can cause blindness and other injuries. |
| 3. Caustic liquid/chemical burn hazard | 8. Battery acid can cause blindness or severe burns. |
| 4. Wear eye protection. | 9. Flush eyes immediately with water and get medical help fast. |
| 5. Read the <i>Operator's Manual</i> . | 10. Contains lead; do not discard |

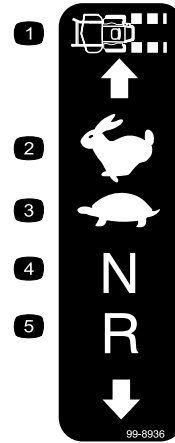

99-8936

decal99-8936

- | | |
|------------------|------------|
| 1. Machine speed | 4. Neutral |
| 2. Fast | 5. Reverse |
| 3. Slow | |

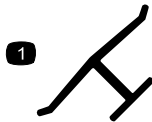

decaloemmark

Manufacturer's Mark

- This mark indicates that the blade is identified as a part from the original machine manufacturer.

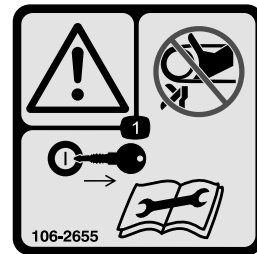

106-2655

decal106-2655

106-2655

- Warning—do not touch or approach moving belts; remove the key and read the instructions before servicing or performing maintenance.



decal58-6520

58-6520

- Grease



106-5517

decal106-5517

106-5517

- Warning—do not touch the hot surface.



107-3069

decal107-3069

1. Warning—there is no rollover protection when the roll bar is down.
2. To avoid injury or death from a rollover accident, keep the roll bar in the raised and locked position and wear the seat belt. Lower the roll bar only when absolutely necessary; do not wear the seat belt when the roll bar is down.
3. Read the *Operator's Manual*; drive slowly and carefully.

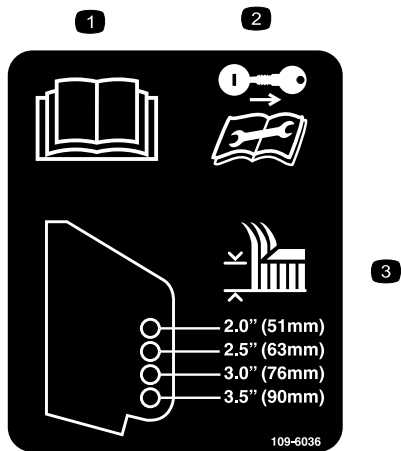

109-6036

decal109-6036

Rear Discharge Machines Only

1. Read the *Operator's Manual*.
2. Remove the key and read the instructions before servicing or performing maintenance.
3. Height of cut

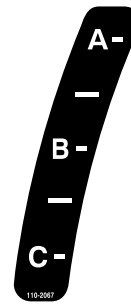

110-2067

decal110-2067

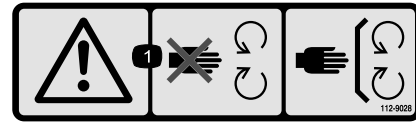

112-9028

decal112-9028

1. Warning—stay away from moving parts; keep all guards and shields in place.

Machines with MyRide™ Only

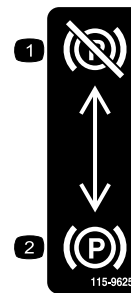

115-9625

decal115-9625

1. Parking brake—disengaged
2. Parking brake—engaged

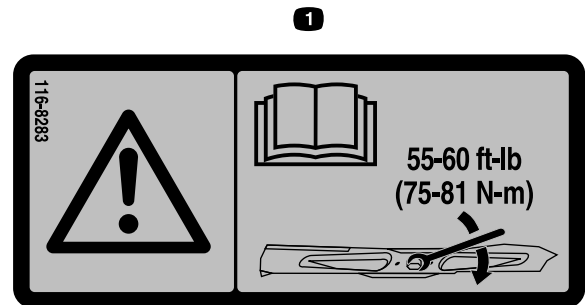

116-8283

decal116-8283

1. Warning—read the *Operator's Manual* for instructions on torquing the blade bolt/nut to 75 to 81 N·m (55 to 60 ft·lb).

WARNING: Cancer and Reproductive Harm - www.P65Warnings.ca.gov.
For more information, please visit www.ticoCAProp65.com

CALIFORNIA SPARK ARRESTER WARNING
Operation of this equipment may create sparks that can start fires around dry vegetation. A spark arrester may be required. The operator should contact local fire agencies for laws or regulations relating to fire prevention requirements.

133-8062

133-8062

decal133-8062

Machines without MyRide™ Only

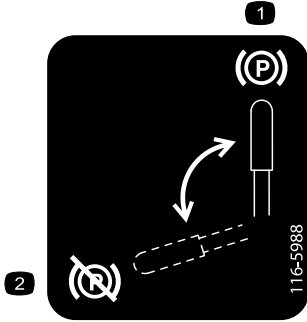

116-5988

decal116-5988

1. Parking brake—engaged
2. Parking brake—disengaged



116-8726

decal116-8726

1. Read the *Operator's Manual* for the recommended hydraulic fluid.

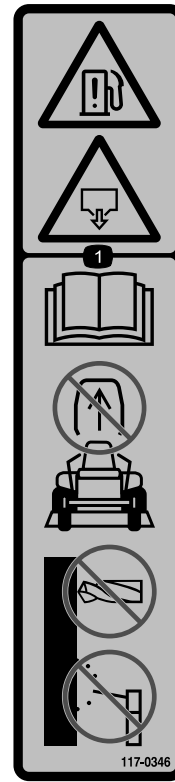

117-0346

decal117-0346

1. Fuel leak hazard—read the *Operator's Manual*; do not attempt to remove the roll bar; do not weld, drill or modify the roll bar in any way.



117-3848

decal117-3848

1. Thrown object hazard—keep bystanders away.
2. Thrown object hazard, raised deflector—do not operate without the deflector, discharge cover, or grass collection system in place.
3. Cutting/dismemberment hazard of hand or foot, mower blade—stay away from moving parts; keep all guards and shields in place.

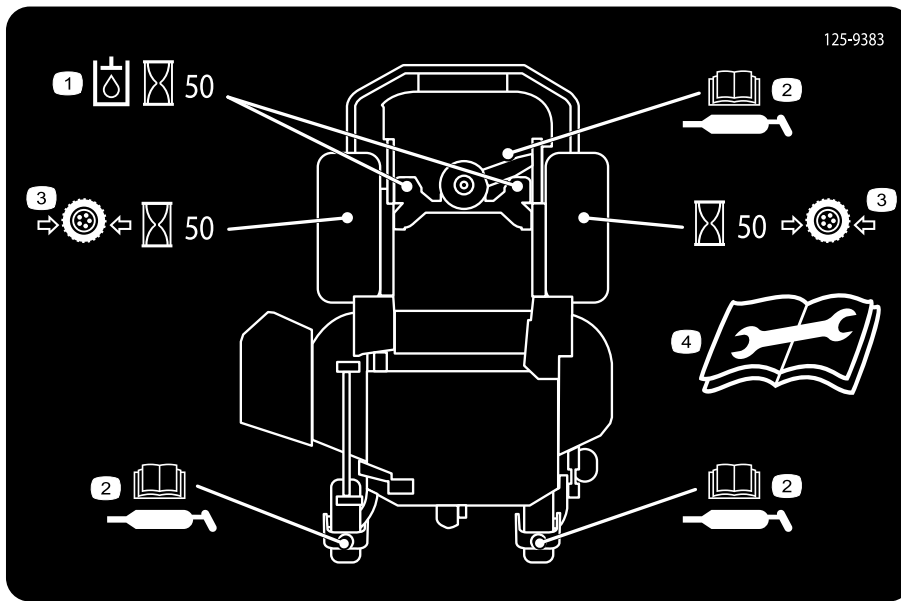

125-9383

125-9383

decal125-9383

1. Check hydraulic fluid every 50 operating hours.
2. Read the *Operator's Manual* for information on lubricating the machine.
3. Check the tire pressure every 50 operating hours.
4. Read the *Operator's Manual* before servicing or performing maintenance.



decal126-2055

126-2055

1. Wheel lug nut—torque to 129 N·m (95 ft-lb).
2. Wheel hub nut—torque to 319 N·m (235 ft-lb).
3. Read the *Operator's Manual* before performing maintenance; check the torque after the first 100 hours and every 500 hours after.

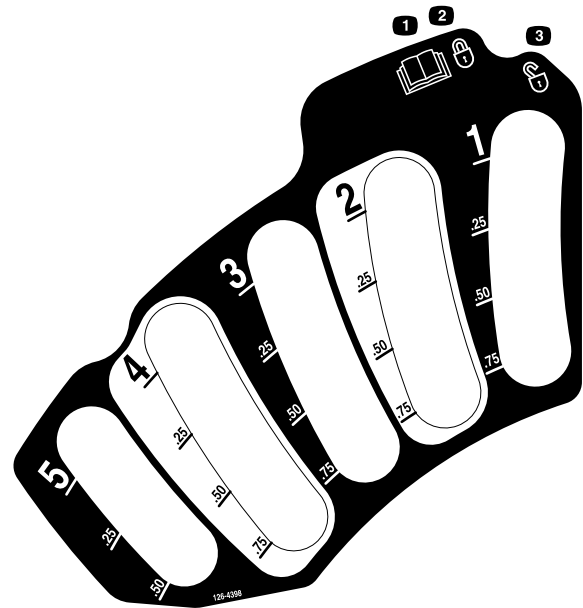

decal126-4398

126-4398

1. Read the *Operator's Manual*.
2. Lock
3. Unlock



126-4659

126-4659

decal126-4659

1. Warning—hot pulley; allow to cool.

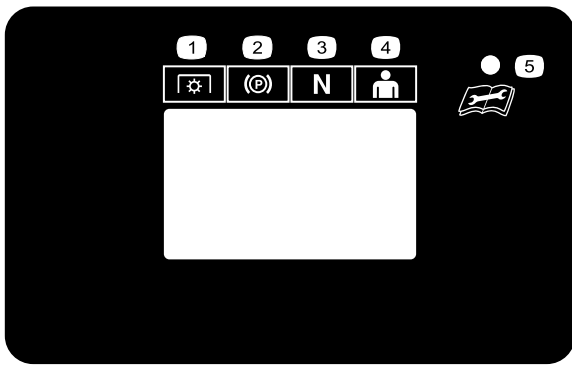

126-5641

g224114

1. PTO
2. Parking brake
3. Neutral
4. Operator-presence switch
5. See user's guide for operating condition code

Machines with Rear Discharge Only

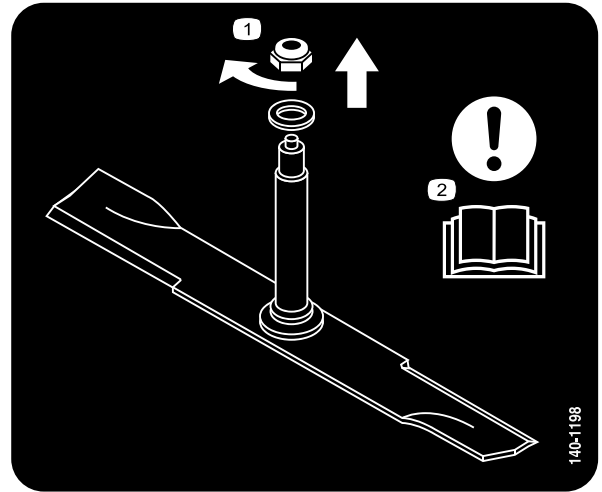

140-1198

decal140-1198

1. Rotate the nut clockwise to remove.
2. Attention—read the *Operator's Manual*.

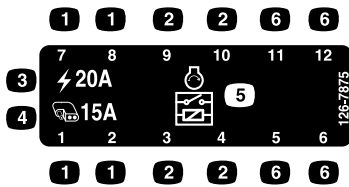

126-7875

decal126-7875

1. Fuse location
2. Relay location
3. Main, 20A
4. Auxiliary, 15A
5. Start relay
6. Not used

Machines with Side Discharge Only

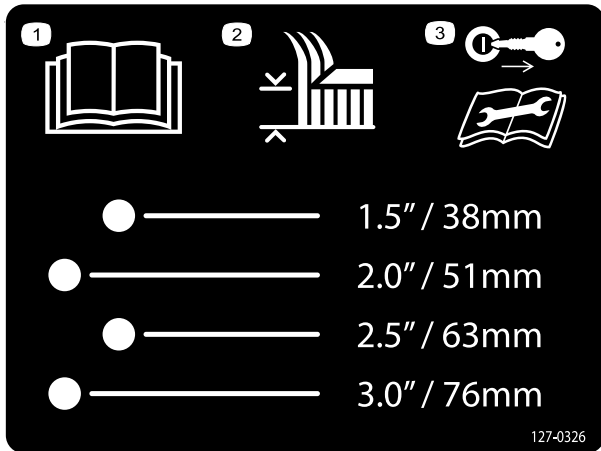

127-0326

decal127-0326

1. Read the *Operator's Manual*.
2. Height of cut
3. Remove the key and read the *Operator's Manual* before performing maintenance.

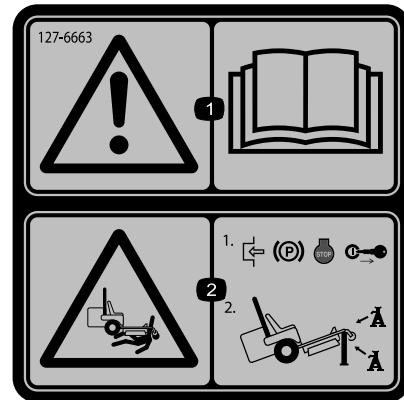

127-6663

decal127-6663

1. Warning—read the *Operator's Manual*.
2. Crushing hazard—engage the parking brake, shut off the engine, and remove the key; support the machine using jackstands.

Machines with Side Discharge Only

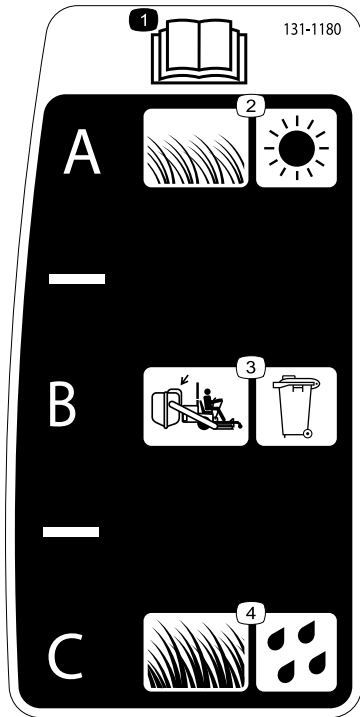

131-1180

decal131-1180

- | | |
|--|--------------------------------------|
| 1. Read the <i>Operator's Manual</i> . | 3. Bagging setting |
| 2. Short, light grass; dry conditions | 4. Tall, dense grass; wet conditions |

Machines with Side Discharge Only

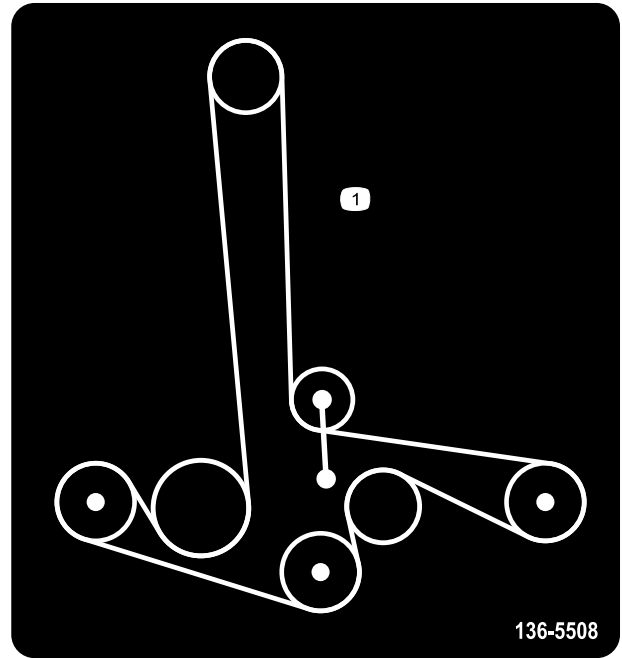

136-5508

decal136-5508

1. Belt routing

Machines with MyRide™ Only

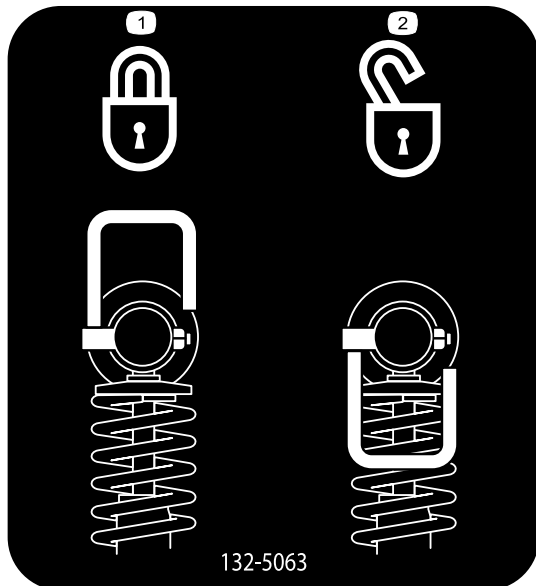

132-5063

decal132-5063

- | | |
|-------------|---------------|
| 1. Cam lock | 2. Cam unlock |
|-------------|---------------|



132-0871

decal132-0871

Note: This machine complies with the industry standard stability test in the static lateral and longitudinal tests with the maximum recommended slope indicated on the decal. Review the instructions for operating the machine on slopes in the *Operator's Manual* as well as the conditions in which you would operate the machine to determine whether you can operate the machine in the conditions on that day and at that site. Changes in the terrain can result in a change in slope operation for the machine.

1. Warning—read the *Operator's Manual*; all operators should be trained before operating the machine; wear hearing protection.
2. Cutting/dismemberment hazard of hand—stay away from moving parts; keep all guards and shields in place.
3. Thrown object hazard—keep bystanders away.
4. Tipping hazard—do not use dual ramps when loading onto a trailer; use 1 ramp wide enough for the machine; use a ramp with a slope less than 15° ; back up the ramp (in reverse) and drive forward off the ramp.
5. Runover hazard—do not carry passengers; look behind you when moving in reverse.
6. Tipping hazard—do not use the machine near drop-offs or on slopes greater than 15° ; only operate across slopes less than 15° .

Machines with MyRide™ Only



132-5067

decal132-5067

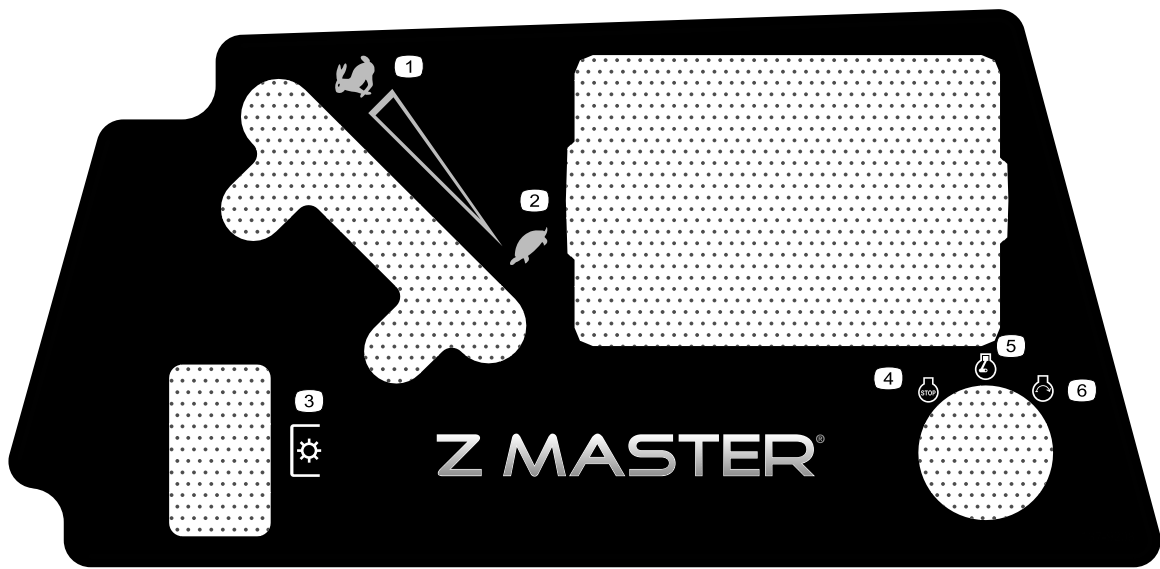

137-9208

decal137-9208

- | | |
|---------|-----------------|
| 1. Fast | 4. Engine—stop |
| 2. Slow | 5. Engine—run |
| 3. PTO | 6. Engine—start |

Machines with Rear Discharge Only

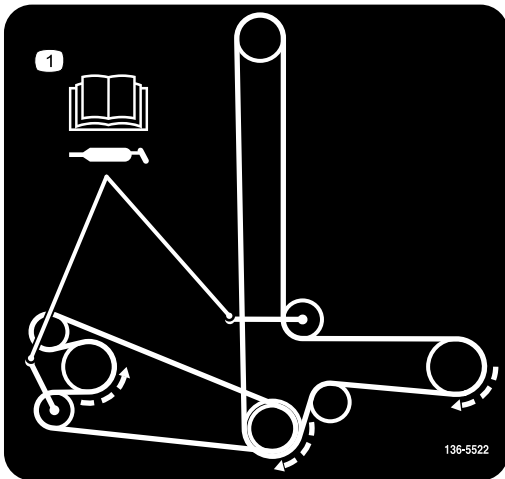

decal136-5522

136-5522

1. Belt routing; read the *Operator's Manual* for greasing information.

Product Overview

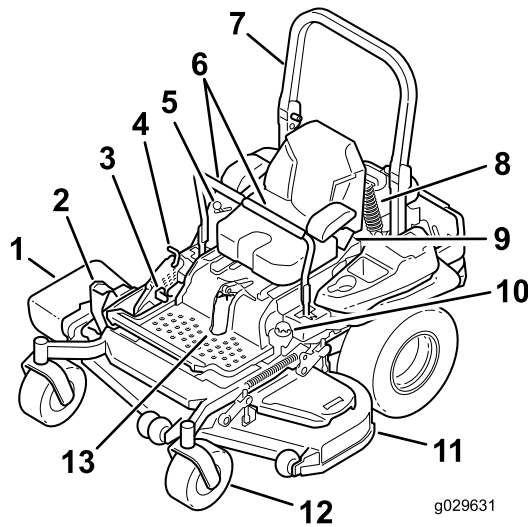

Figure 4

Side Discharge Machine Shown

- | | |
|----------------------------------|---|
| 1. Side-discharge deflector | 8. Rear-shock assembly (machines with MyRide™ only) |
| 2. Height-of-cut deck-lift pedal | 9. Seat belt |
| 3. Parking-brake lever | 10. Fuel cap |
| 4. Transport lock | 11. Mower deck |
| 5. Controls | 12. Caster wheel |
| 6. Motion-control levers | 13. Front-shock assembly (machines with MyRide™ only) |
| 7. Roll bar | |

Controls

Become familiar with all the controls before you start the engine and operate the machine.

Control Panel

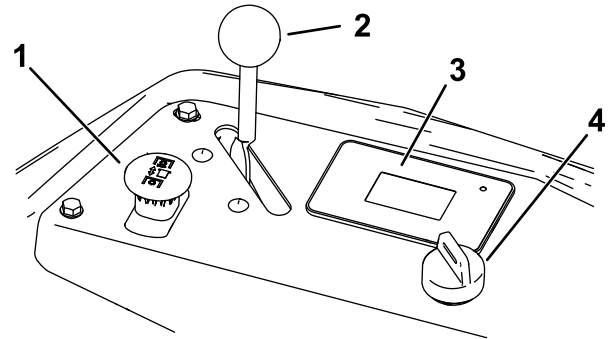

Figure 5

- | | |
|---|--|
| 1. Blade-control switch (power takeoff) | 3. Hour meter/Safety-interlock display |
| 2. Throttle control | 4. Key switch |

Key Switch

The key switch, used to start and shut off the engine, has 3 positions: OFF, RUN, and START. Refer to [Starting the Engine \(page 29\)](#).

Throttle Control

The throttle controls the engine speed, and it has a continuous-variable setting from the SLOW to FAST position ([Figure 5](#)).

Choke Control

Use the choke control to start a cold engine.

Blade-Control Switch (Power Takeoff)

The blade-control switch, represented by a power-takeoff (PTO) symbol, engages and disengages power to the mower blades ([Figure 5](#)).

Hour Meter

The hour meter records the number of hours the engine has operated. It operates when the engine is running. Use these times for scheduling regular maintenance ([Figure 6](#)).

The hour meter displays when you are operating the machine and momentarily when you shut off the engine. The display turns off after 5 minutes.

Refer to the *Software Guide* for more information.

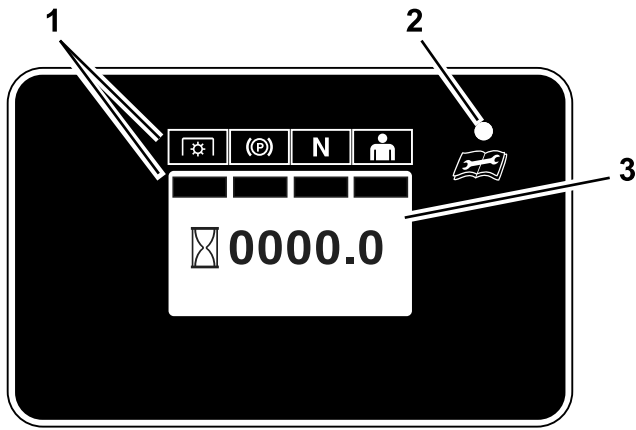

Figure 6

g231075

1. Safety-interlock indicators
2. LED status light
3. Information screen

the machine ([Figure 25](#)). Always position the motion-control levers into the NEUTRAL-LOCK position when you stop the machine or leave it unattended.

Parking-Brake Lever

Whenever you shut off the engine, engage the parking brake to prevent accidental movement of the machine.

Fuel-Shutoff Valve

Close the fuel-shutoff valve when transporting or storing the machine; refer to [Using the Fuel-Shutoff Valve \(page 37\)](#).

LED Status Light

The LED is multi-colored to indicate the system status and is located on the right side of the panel.

- **Solid Green**—indicates normal operating activity.
- **Blinking Red**—indicates a fault is active.
- **Blinking Green and Orange**—indicates a clutch reset is required.
- **Solid Red**—indicates maintenance is required.

Refer to the *Software Guide* for more information.

Fuel Gauge

When the fuel-tank level is low, the LED status light flashes a red light and the fuel-level symbol on the screen flashes.

Refer to the *Software Guide* for more information.

Safety-Interlock Indicators

There are symbols on the hour meter that indicate with a black bar that the interlock component is positioned correctly ([Figure 6](#)).

Motion-Control Levers

Use the motion-control levers to drive the machine forward, reverse, and turn either direction ([Figure 4](#)).

Neutral-Lock Position

Move the motion-control levers outward from the center to the NEUTRAL-LOCK position when exiting

Specifications

Note: Specifications and design are subject to change without notice.

Machines with Side Discharge

Width:

	48-inch Deck	52-inch Deck	60-inch Deck	72-inch Deck
Without Deck	116 cm (46 inches)	116 cm (46 inches)	135 cm (53 inches)	150 cm (59 inches)
Deflector Up	137 cm (54 inches)	146 cm (58 inches)	157 cm (62 inches)	187 cm (74 inches)
Deflector Down	161 cm (64 inches)	172 cm (68 inches)	192 cm (76 inches)	222 cm (88 inches)

Length:

	48-inch Deck	52-inch Deck	60-inch Deck	72-inch Deck
Roll Bar—Up	201 cm (79 inches)	201 cm (79 inches)	211 cm (83 inches)	219 cm (86 inches)
Roll Bar—Down	206 cm (81 inches)	206 cm (81 inches)	215 cm (85 inches)	223 cm (88 inches)

Height:

Roll Bar—Up	Roll Bar—Down
179.1 cm (70.5 inches)	118.9 cm (46.8 inches)

Weight:

Model	Weight
48-inch Mower Deck	508 kg (1,120 lb)
52-inch Mower Deck	533 kg (1,174 lb)
60-inch Mower Deck	569 kg (1,255 lb)
72-inch Mower Deck	612 kg (1,350 lb)

Machines with Rear Discharge

Width:

	60-inch Mower Deck	72-inch Mower Deck
Without Mower Deck	134.6 cm (53.0 inches)	150.1 cm (59.1 inches)
With Mower Deck	168.4 cm (66.3 inches)	199.0 cm (78.3 inches)

Length:

	60-inch Mower Deck	72-inch Mower Deck
Roll Bar - Up	221.6 cm (87.25 inches)	221.6 cm (87.25 inches)
Roll Bar - Down	226.0 cm (88.95 inches)	226.0 cm (88.95 inches)

Height:

Roll Bar - Up	Roll Bar - Down
179.1 cm (70.5 inches)	118.9 cm (46.8 inches)

Weight:

Model	Weight
60-inch Mower Deck	577 kg (1,271 lb)
72-inch Mower Deck	606 kg (1,335 lb)

Attachments/Accessories

A selection of Toro approved attachments and accessories is available for use with the machine to enhance and expand its capabilities. Contact your Authorized Service Dealer or authorized Toro distributor or go to www.Toro.com for a list of all approved attachments and accessories.

To ensure optimum performance and continued safety certification of the machine, use only genuine Toro replacement parts and accessories. Replacement parts and accessories made by other manufacturers could be dangerous, and such use could void the product warranty.

Operation

Note: Determine the left and right sides of the machine from the normal operating position.

Before Operation

Before Operation Safety

General Safety

- Evaluate the terrain to determine what accessories and attachments are needed to properly and safely perform the job. Only use accessories and attachments approved by Toro.
- Inspect the area where the equipment is to be used and remove all rocks, toys, sticks, wires, bones, and other foreign objects. These can be thrown or interfere with the operation of the machine and may cause personal injury to the operator or bystanders.
- Wear appropriate personal protective equipment such as safety glasses, substantial slip-resistant footwear, and hearing protection. Tie back long hair and avoid loose clothing and loose jewelry which may get tangled in moving parts.

⚠ CAUTION

This machine produces sound levels in excess of 85 dBA at the operator's ear and can cause hearing loss through extended periods of exposure.

Wear hearing protection when operating this machine.

- Check that the operator presence controls, safety switches, and shields are attached and functioning properly. Do not operate unless they are functioning properly.
- Do not operate the mower when people, especially children, or pets are in the area. Stop the machine and attachment(s) if anyone enters the area.
- Do not operate the machine without the entire grass collection system, discharge deflector, or other safety devices in place and in proper working condition. Grass catcher components are subject to wear, damage and deterioration, which could expose moving parts or allow objects to be thrown. Frequently check for worn or deteriorating components and replace them with the manufacturer's recommended parts when necessary.

Fuel Safety

Use extreme care when handling fuel.

⚠ DANGER

In certain conditions gasoline is extremely flammable and vapors are explosive.

A fire or explosion from gasoline can burn you, others, and cause property damage.

- **Fill the fuel tank outdoors on level ground, in an open area, when the engine is cold. Wipe up any gasoline that spills.**
- **Never refill the fuel tank or drain the machine indoors or inside an enclosed trailer.**
- **Do Not fill the fuel tank completely full. Fill the fuel tank to the bottom of the filler neck. The empty space in the tank allows gasoline to expand. Overfilling may result in fuel leakage or damage to the engine or emission system.**
- **Never smoke when handling gasoline, and stay away from an open flame or where gasoline fumes may be ignited by spark.**
- **Store gasoline in an approved container and keep it out of the reach of children.**
- **Add fuel before starting the engine. Never remove the cap of the fuel tank or add fuel when engine is running or when the engine is hot.**
- **If fuel is spilled, Do Not attempt to start the engine. Move away from the area of the spill and avoid creating any source of ignition until fuel vapors have dissipated.**
- **Do Not operate without entire exhaust system in place and in proper working condition.**

⚠ DANGER

In certain conditions during fueling, static electricity can be released causing a spark which can ignite gasoline vapors. A fire or explosion from gasoline can burn you and others and cause property damage.

- Always place gasoline containers on the ground away from your vehicle before filling.
- Do Not fill gasoline containers inside a vehicle or on a truck or trailer bed because interior carpets or plastic truck bed liners may insulate the container and slow the loss of any static charge.
- When practical, remove gas-powered equipment from the truck or trailer and refuel the equipment with its wheels on the ground.
- If this is not possible, then refuel such equipment on a truck or trailer from a portable container, rather than from a gasoline dispenser nozzle.
- If a gasoline dispenser nozzle must be used, keep the nozzle in contact with the rim of the fuel tank or container opening at all times until fueling is complete. Do Not use a nozzle lock open device.

⚠ WARNING

Gasoline is harmful or fatal if swallowed. Long-term exposure to vapors has caused cancer in laboratory animals. Failure to use caution may cause serious injury or illness.

- Avoid prolonged breathing of vapors.
- Keep face away from nozzle and gas tank/container opening.
- Keep away from eyes and skin.
- Never siphon by mouth.

⚠ CAUTION

Fuel tank vent is located inside the roll bar tube. Removing or modifying the roll bar could result in fuel leakage and violate emissions regulations.

- Do Not remove roll bar.
- Do Not weld, drill, or modify roll bar in any way.

To help prevent fires:

- Keep engine and engine area free from accumulation of grass, leaves, excessive grease or oil, and other debris which can accumulate in these areas.
- Clean up oil and fuel spills and remove fuel soaked debris.
- Allow the machine to cool before storing the machine in any enclosure. Do Not store near flame or any enclosed area where open pilot lights or heat appliances are present.

Adding Fuel

Recommended Fuel

- For best results, use only clean, fresh (less than 30 days old), unleaded gasoline with an octane rating of 87 or higher ((R+M)/2 rating method).
- **Ethanol:** Gasoline with up to 10% ethanol (gasohol) or 15% MTBE (methyl tertiary butyl ether) by volume is acceptable. Ethanol and MTBE are not the same. Gasoline with 15% ethanol (E15) by volume is not approved for use. **Never use gasoline that contains more than 10% ethanol by volume**, such as E15 (contains 15% ethanol), E20 (contains 20% ethanol), or E85 (contains up to 85% ethanol). Using unapproved gasoline may cause performance problems and/or engine damage which may not be covered under warranty.
- **Do not** use gasoline containing methanol.
- **Do not** store fuel either in the fuel tank or fuel containers over the winter unless you use a fuel stabilizer.
- **Do not** add oil to gasoline.

Using Stabilizer/Conditioner

Use a fuel stabilizer/conditioner in the machine to provide the following benefits:

- Keeps fuel fresh longer when used as directed by the fuel-stabilizer manufacturer
- Cleans the engine while it runs
- Eliminates gum-like varnish buildup in the fuel system, which causes hard starting

Important: Do not use fuel additives containing methanol or ethanol.

Add the correct amount of fuel stabilizer/conditioner to the fuel.

Note: A fuel stabilizer/conditioner is most effective when mixed with fresh fuel. To minimize the chance of varnish deposits in the fuel system, use fuel stabilizer at all times.

Filling the Fuel Tank

1. Park the machine on a level surface.
2. Engage the parking brake.
3. Shut off the engine and remove the key.
4. Clean around the fuel-tank cap.
5. Fill the fuel tank to the bottom of the filler neck (Figure 7).

Note: Do not fill the fuel tank completely full. The empty space in the tank allows the fuel to expand.

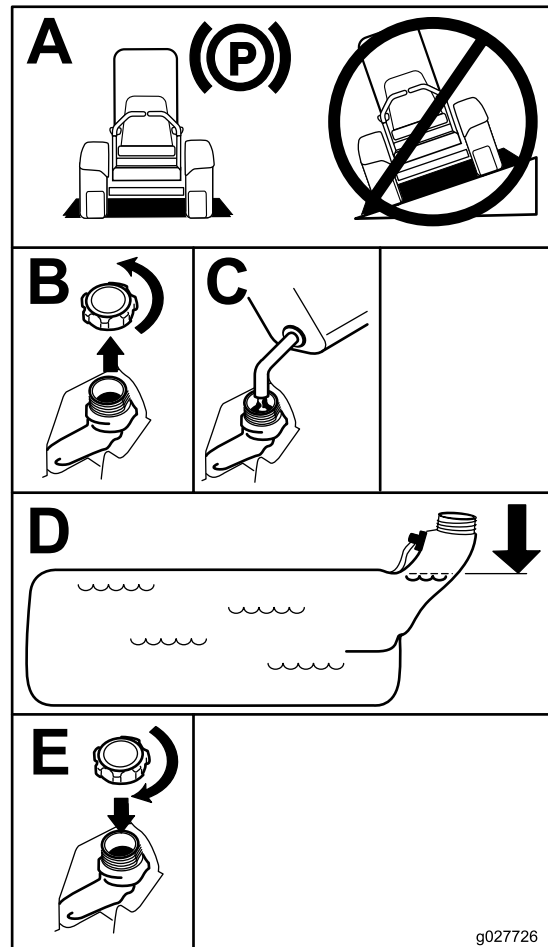

Figure 7

g027726

Performing Daily Maintenance

Before starting the machine each day, perform the Each Use/Daily procedures listed in [Maintenance \(page 40\)](#).

Breaking in a New Machine

New engines take time to develop full power. Mower decks and drive systems have higher friction when new, placing additional load on the engine. Allow 40 to 50 hours of break-in time for new machines to develop full power and best performance.

Using the Rollover-Protection System (ROPS)

⚠ WARNING

To avoid injury or death from rollover, keep the roll bar in the fully raised, locked position and use the seat belt.

Ensure that the seat is secured to the machine.

⚠ WARNING

There is no rollover protection when the roll bar is in the down position.

- Lower the roll bar only when absolutely necessary.
- Do not wear the seat belt when the roll bar is in the down position.
- Drive slowly and carefully.
- Raise the roll bar as soon as clearance permits.
- Check carefully for overhead clearances (i.e., branches, doorways, electrical wires) before driving under any objects and do not contact them.

Lowering the Roll Bar

Important: Lower the roll bar only when absolutely necessary.

1. To lower the roll bar, apply forward pressure to the upper part of the roll bar.
2. Pull both knobs out and rotate them 90 degrees so they are not engaged (Figure 8).
3. Lower the roll bar to the down position (Figure 8).

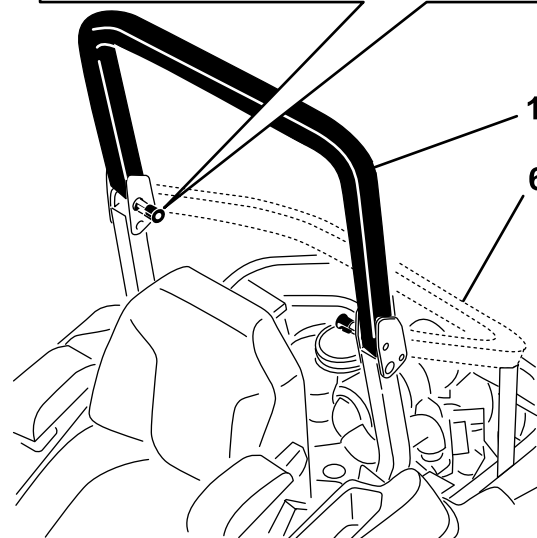
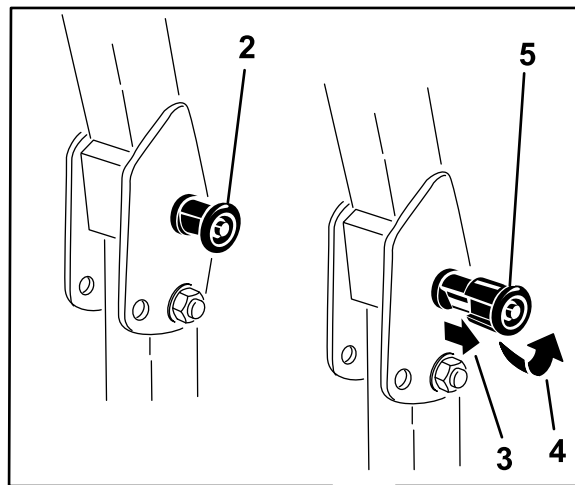

Figure 8

g228804

1. Roll bar in the upright position
2. ROPS knob in the latched position
3. Pull the ROPS knob out.
4. Rotate the ROPS knob 90 degrees.
5. ROPS knob in the unlatched position
6. Roll bar in the folded position

Raising the Roll Bar

Important: Always use the seat belt with the roll bar in the raised position.

1. Raise the roll bar to the operating position and rotate the knobs until they move partially into the grooves (Figure 8).
2. Raise the roll bar to the full upright position while pushing on the upper roll bar so that the pins snap into position when the holes align with the pins (Figure 8).
3. Push on the roll bar and ensure that both pins are engaged.

Using the Safety-Interlock System

⚠ WARNING

If the safety-interlock switches are disconnected or damaged, the machine could operate unexpectedly, causing personal injury.

- Do not tamper with the interlock switches.
- Check the operation of the interlock switches daily and replace any damaged switches before operating the machine.

Understanding the Safety-Interlock System

The safety-interlock system is designed to prevent the engine from starting unless the following occurs:

- The parking brake is engaged.
- The blade-control switch (PTO) is disengaged.
- The motion-control levers are in the NEUTRAL-LOCK position.

The safety-interlock system also is designed to shut off the engine when the motion-control levers are moved from the NEUTRAL-LOCK position with the parking brake engaged or if you rise from the seat when the PTO is engaged.

The hour meter has indicators to notify the user when the interlock component is in the correct position. When the component is in the correct position, an indicator displays on the screen.

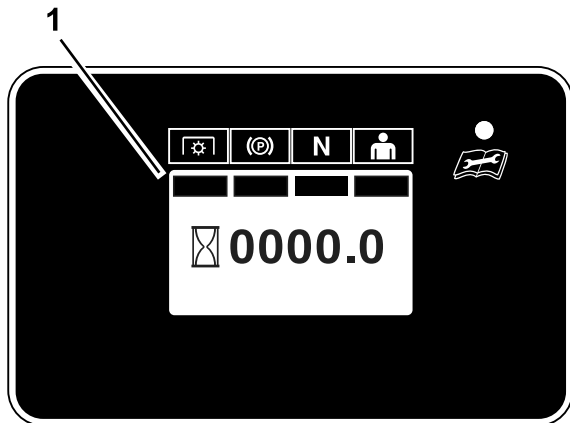

Figure 9

g231781

1. Indicators display when the interlock components are in the correct position

Testing the Safety-Interlock System

Service Interval: Before each use or daily

Test the safety-interlock system before you use the machine each time. If the safety system does not operate as described below, have an Authorized Service Dealer repair the safety system immediately.

1. Sit on the seat, engage the parking brake, and move the blade-control switch (PTO) to the ON position. Try starting the engine; the engine should not start.
2. Sit on the seat, engage the parking brake, and move the blade-control switch (PTO) to the OFF position. Move either motion-control lever out of the NEUTRAL-LOCK position. Try starting the engine; the engine should not start. Repeat for the other control lever.
3. Sit on the seat, engage the parking brake, move the blade-control switch (PTO) to the OFF position, and move the motion-control levers to the NEUTRAL-LOCK position. Now start the engine. While the engine is running, disengage the parking brake, engage the blade-control switch (PTO), and rise slightly from the seat; the engine should shut off.
4. Sit on the seat, engage the parking brake, move the blade-control switch (PTO) to the OFF position, and move the motion-control levers to the NEUTRAL-LOCK position. Now start the engine. While the engine is running, center either motion control and move (forward or reverse); the engine should shut off. Repeat for other motion control.
5. Sit on the seat, disengage the parking brake, move the blade-control switch (PTO) to the OFF position, and move the motion-control levers to the NEUTRAL-LOCK position. Try starting the engine; the engine should not start.

Positioning the Seat

The seat can move forward and backward. Position the seat where you have the best control of the machine and are most comfortable (Figure 10).

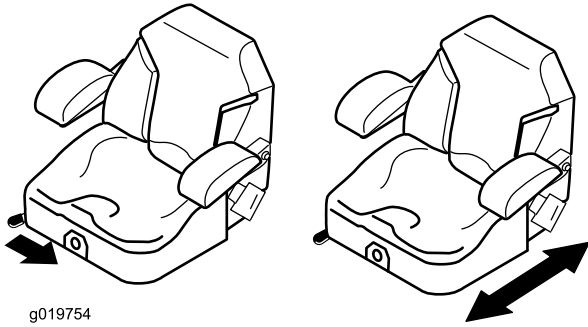

Figure 10

Machines without MyRide™ Suspension System

To unlatch the seat, push the seat latch forward (Figure 12).

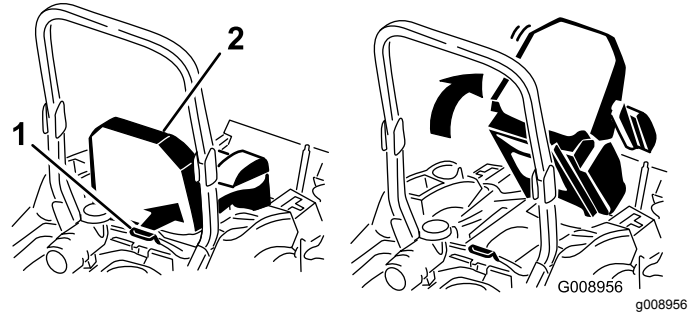

Figure 12

1. Seat latch

2. Seat

Unlatching the Seat

Machines with MyRide™ Suspension System

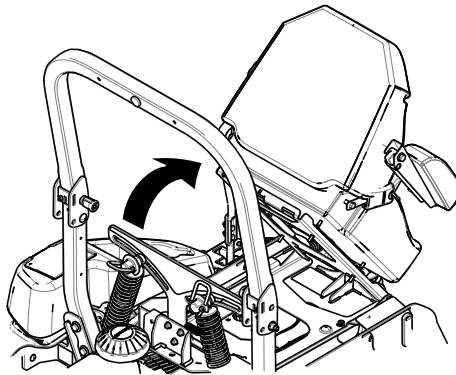
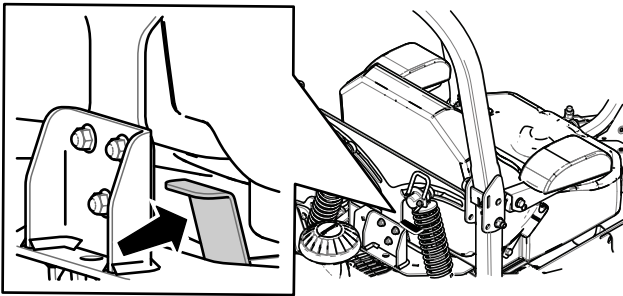

Figure 11

Changing the Seat Suspension

Machines without MyRide™ Suspension System Only

The seat is adjustable to provide a smooth and comfortable ride. Position the seat where you are most comfortable.

To adjust it, turn the knob in front either direction to provide the best comfort (Figure 13).

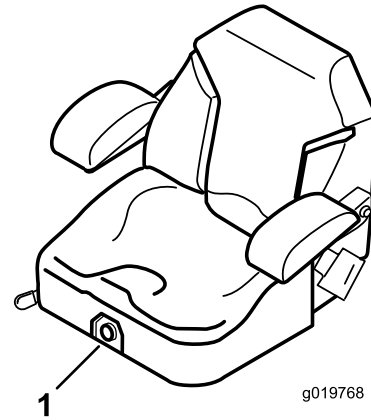

Figure 13

1. Seat-suspension knob

Adjusting the Rear-Shock Assemblies

Machines with MyRide™ Suspension System Only

The MyRide™ suspension system adjusts to provide a smooth and comfortable ride. You can adjust the rear 2-shock assemblies to quickly and easily change the suspension system. Position the suspension system where you are most comfortable.

The slots for the rear-shock assemblies have detent positions for reference. You can position the rear-shock assemblies anywhere in the slot, not just in the detent positions. The following graphic shows the position for a soft or firm ride and the different detent positions (Figure 14).

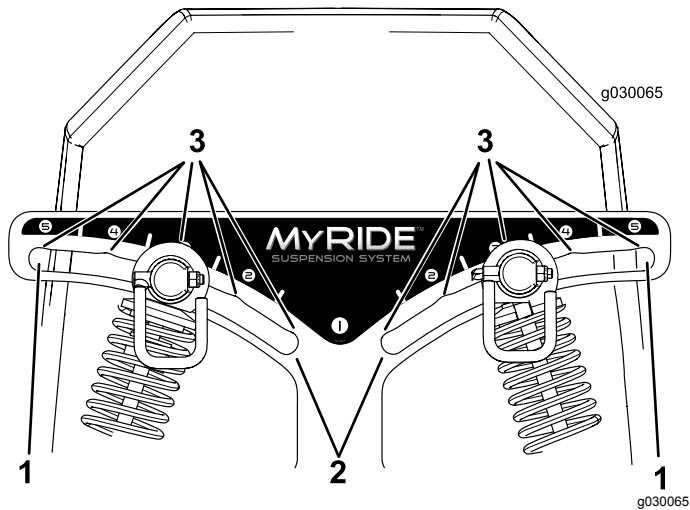

Figure 14

- 1. Firmest position
- 2. Softest position
- 3. Detents in the slots

Note: Ensure that the left and right rear-shock assemblies are always adjusted to the same positions.

Adjust the rear-shock assemblies (Figure 15).

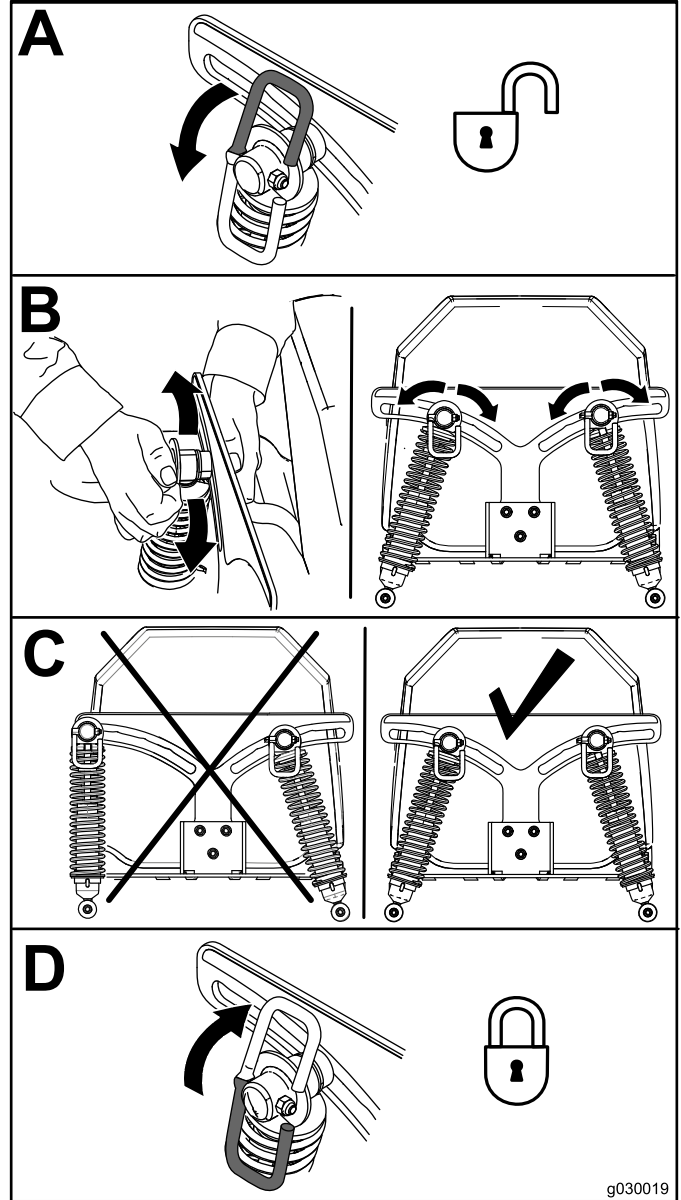
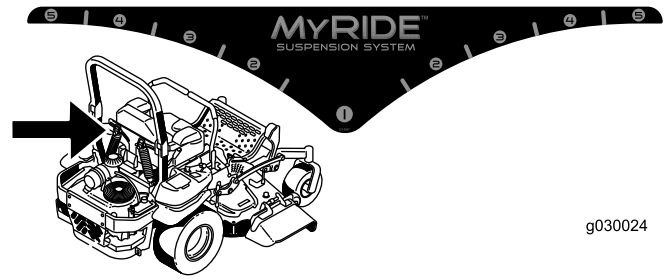

Figure 15

During Operation

During Operation Safety

General Safety

The operator must use their full attention when operating the machine. **Do Not** engage in any activity that causes distractions; otherwise, injury or property damage may occur.

⚠ WARNING

Operating engine parts, especially the muffler, become extremely hot. Severe burns can occur on contact and debris, such as leaves, grass, brush, etc. can catch fire.

- **Allow engine parts, especially the muffler, to cool before touching.**
- **Remove accumulated debris from muffler and engine area.**

⚠ WARNING

Engine exhaust contains carbon monoxide, which is an odorless deadly poison that can kill you.

Do Not run engine indoors or in a small confined area where dangerous carbon monoxide fumes can collect.

- The owner/user can prevent and is responsible for accidents or injuries occurring to himself or herself, other people or property.
- This mower was designed for one operator only. Do not carry passengers and keep all others away from machine during operation.
- Do not operate the machine while ill, tired, or under the influence of alcohol or drugs.
- Operate only in daylight or good artificial light.
- Lightning can cause severe injury or death. If lightning is seen or thunder is heard in the area, Do Not operate the machine; seek shelter.
- Use extra care while operating with accessories or attachments, such as grass collection systems. These can change the stability of the machine and cause a loss of control. Follow directions for counter weights if required.
- Keep away from holes, ruts, bumps, rocks, and other hidden hazards. Use care when approaching blind corners, shrubs, trees, tall grass or other objects that may hide obstacles or obscure vision. Uneven terrain could overturn the machine or cause the operator to lose their balance or footing.

- Be sure all drives are in neutral and parking brake is engaged before starting engine. Use seat belts with the roll bar in the raised and locked position.
- Start the engine carefully according to instructions with feet well away from the blades.
- Never operate the mower with damaged guards, shields, or covers. Always have safety shields, guards, switches and other devices in place and in proper working condition.
- Keep clear of the discharge opening at all times. Never mow with the discharge door raised, removed or altered unless there is a grass collection system or mulch kit in place and working properly.
- Keep hands and feet away from moving parts. If possible, Do Not make adjustments with the engine running.

⚠ WARNING

Hands, feet, hair, clothing, or accessories can become entangled in rotating parts. Contact with the rotating parts can cause traumatic amputation or severe lacerations.

- **Do Not operate the machine without guards, shields, and safety devices in place and working properly.**
- **Keep hands, feet, hair, jewelry, or clothing away from rotating parts.**

- Never raise the deck with blades running.
- Be aware of the mower discharge path and direct discharge away from others. Avoid discharging material against a wall or obstruction as the material may ricochet back toward the operator. Stop the blades, slow down, and use caution when crossing surfaces other than grass and when transporting the mower to and from the area to be mowed.
- Be alert, slow down and use caution when making turns. Look behind and to the side before changing directions. Do Not mow in reverse unless absolutely necessary.
- Do Not change the engine governor setting or overspeed the engine.
- Park the machine on level ground. Stop engine, wait for all moving parts to stop, and remove the spark plug wire(s).
 - Before checking, cleaning or working on the mower.
 - After striking a foreign object or abnormal vibration occurs (inspect the mower for damage and make repairs before restarting and operating the mower).

- Before clearing blockages.
- Whenever you leave the mower. Do Not leave a running machine unattended.
- Stop engine, wait for all moving parts to stop:
 - Before refueling.
 - Before dumping the grass catcher.
 - Before making height adjustments.
- Tragic accidents can occur if the operator is not alert to the presence of children. Children are often attracted to the machine and the mowing activity. Never assume that children will remain where you last saw them.
 - Keep children out of the mowing area and under the watchful care of another responsible adult, not the operator.
 - Be alert and turn the machine off if children enter the area.
 - Before and while backing or changing direction, look behind, down, and side-to-side for small children.
 - Never allow children to operate the machine.
 - Do Not carry children, even with the blades shut off. Children could fall off and be seriously injured or interfere with the safe operation of the machine. Children that have been given rides in the past could suddenly appear in the working area for another ride and be run over or backed over by the machine.

distance (twice the width of the machine) between the machine and any hazard. Use a walk behind machine or a hand trimmer to mow the grass in these areas.

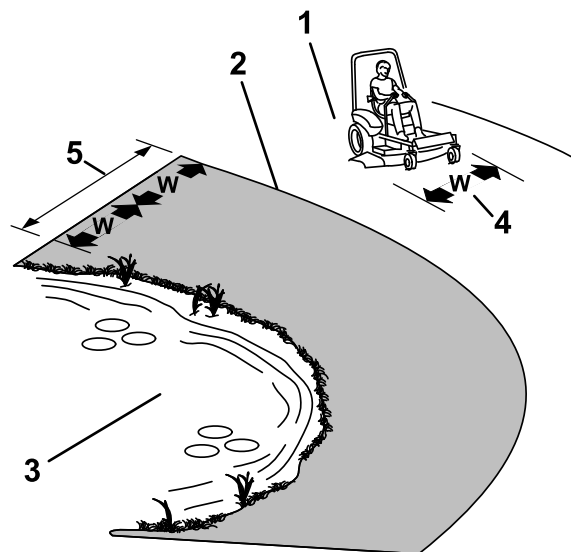

Figure 16

g221745

1. Safe Zone-Use the mower here on slopes less than 15 degrees
2. Danger Zone-Use a walk-behind mower and/or hand trimmer on slopes greater than 15 degrees
3. Water
4. W=width of the machine
5. Keep a safe distance (twice the width of the machine) between the machine and any hazard.

Slope Safety

- Slopes are a major factor related to loss of control and rollover accidents, which can result in severe injury or death. The operator is responsible for safe slope operation. Operating the machine on any slope requires extra caution. Before using the machine on a slope, the operator must:
 - Review and understand the slope instructions in the manual and on the machine.
 - Use an angle indicator to determine the approximate slope angle of the area.
 - Never operate on slopes greater than 15 degrees.
 - Evaluate the site conditions of the day to determine if the slope is safe for machine operation. Use common sense and good judgment when performing this evaluation. Changes in the terrain, such as moisture, can quickly affect the operation of the machine on a slope.
- Identify hazards at the base of the slope. Do Not operate the machine near drop offs, ditches, embankments, water or other hazards. The machine could suddenly roll over if a wheel goes over the edge or the edge collapses. Keep a safe

- Avoid starting, stopping or turning the machine on slopes. Avoid making sudden changes in speed or direction; turn slowly and gradually.
- Do Not operate a machine under any conditions where traction, steering or stability is in question. Be aware that operating the machine on wet grass, across slopes or downhill may cause the machine to lose traction. Loss of traction to the drive wheels may result in sliding and a loss of braking and steering. The machine can slide even if the drive wheels are stopped.
- Remove or mark obstacles such as ditches, holes, ruts, bumps, rocks or other hidden hazards. Tall grass can hide obstacles. Uneven terrain could overturn the machine.
- Use extra care while operating with accessories or attachments, such as grass collection systems. These can change the stability of the machine and cause a loss of control. Follow directions for counter weights.
- If possible, keep the deck lowered to the ground while operating on slopes. Raising the deck while operating on slopes can cause the machine to become unstable.

Rollover Protection System (ROPS) Safety

A Rollover Protection System (roll bar) is installed on the machine.

⚠ WARNING

There is no rollover protection when the roll bar is down. Wheels dropping over edges, ditches, steep banks, or water can cause rollovers, which may result in serious injury, death or drowning.

- **Do Not remove the ROPS.**
- **Keep the roll bar in the raised and locked position and use seat belt.**
- **Lower the roll bar only when absolutely necessary.**
- **Do Not wear seat belt when the roll bar is down.**
- **Drive slowly and carefully.**
- **Raise the roll bar as soon as clearance permits.**
- Be certain that the seat belt can be released quickly in the event of an emergency.
- Check carefully for overhead clearances (i.e. branches, doorways, and electrical wires) before driving under any objects and Do Not contact them.
- In the event of a rollover, take the unit to an Authorized Service Dealer to have the ROPS inspected.
- Replace a damaged ROPS. Do Not repair or revise.
- Any accessories, alterations, or attachments added to the ROPS must be approved by Toro.

Entering the Operator's Position

Use the mower deck as a step to get into the operator's position (Figure 17).

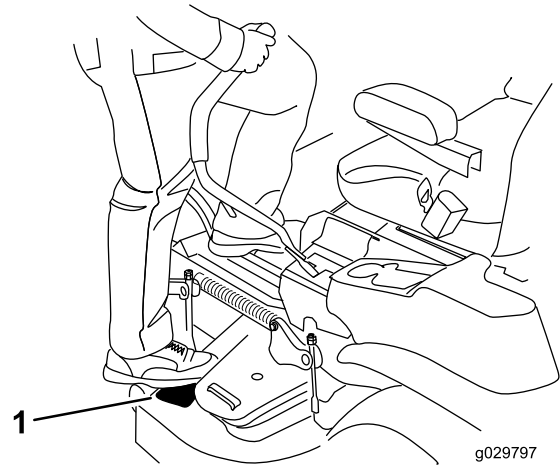

Figure 17

1. Step here.
-

Operating the Parking Brake

Always engage the parking brake when you stop the machine or leave it unattended.

Engaging the Parking Brake

Park the machine on a level surface.

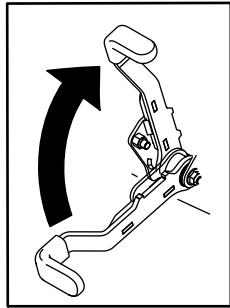

Figure 18

g027334

g027334

Disengaging the Parking Brake

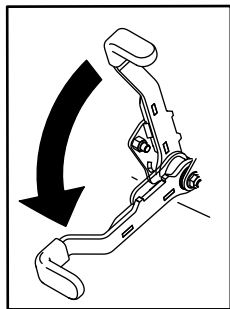

Figure 19

g027335

g027335

Operating the Mower Blade-Control Switch (PTO)

The blade-control switch (PTO) starts and stops the mower blades and any powered attachments.

Engaging the Blade-Control Switch (PTO)

Note: Engaging the blade-control switch (PTO) with the throttle position at half or less causes excessive wear to the drive belts.

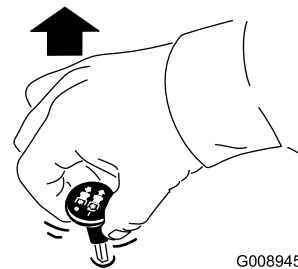

Figure 20

G008945

g008945

Disengaging the Blade-Control Switch (PTO)

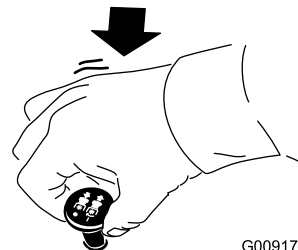

Figure 21

G009174

g009174

Operating the Throttle

You can move the throttle control between FAST and SLOW positions (Figure 22).

Always use the FAST position when engaging the PTO.

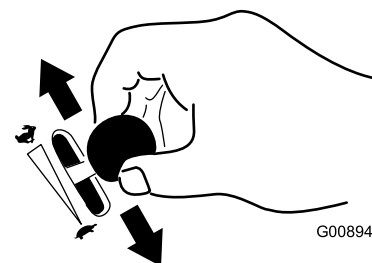

Figure 22

G008946

g008946

Starting the Engine

Important: Do not engage starter for more than 5 seconds at a time. If the engine fails to start, wait 15 seconds between attempts. Failure to follow these instructions can burn out the starter motor.

Note: You may need multiple attempts to start the engine the first time after adding fuel to an empty fuel system.

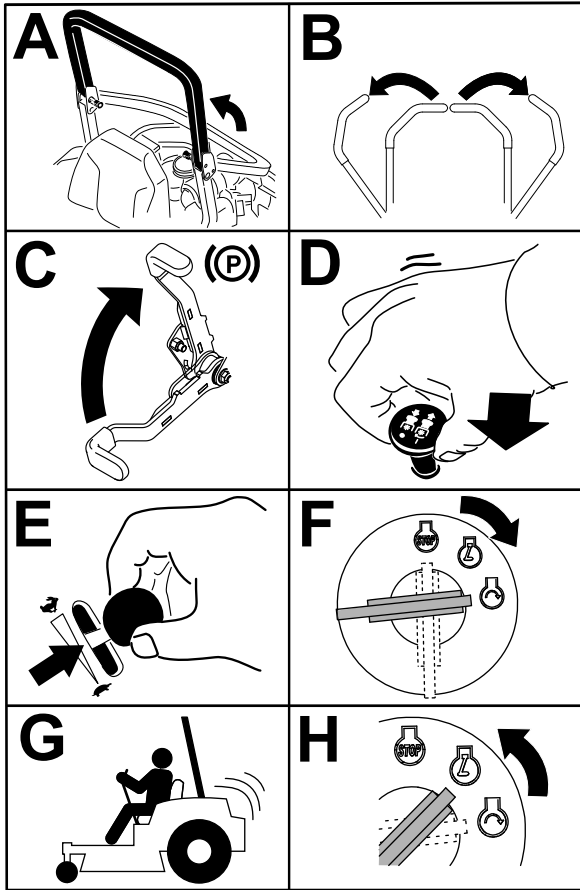

Figure 23

g032328

g032328

Shutting Off the Engine

⚠ CAUTION

Children or bystanders may be injured if they move or attempt to operate the machine while it is unattended.

Always remove the key and engage the parking brake when leaving the machine unattended.

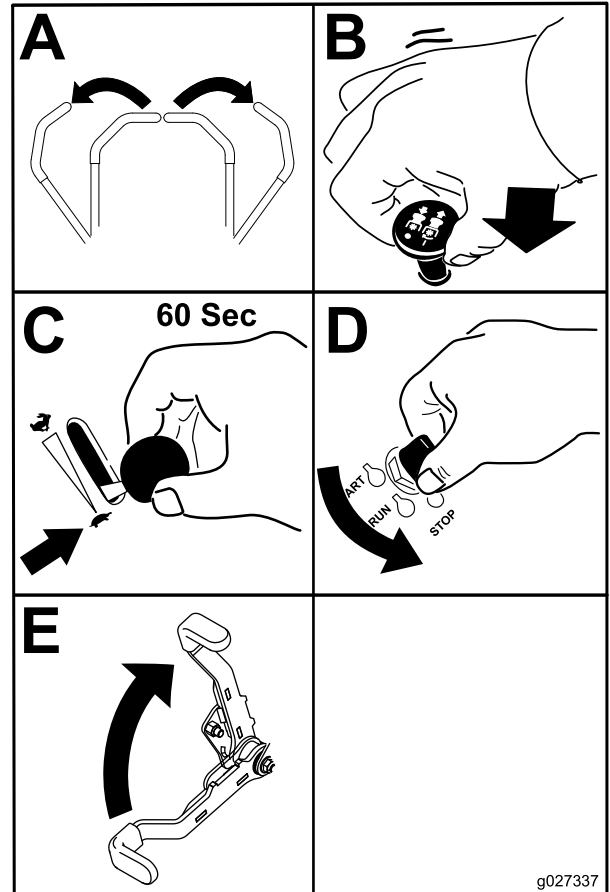

Figure 24

g027337

g027337

Important: Make sure that the fuel-shutoff valve is closed before transporting or storing the machine, as fuel leakage may occur. Engage the parking brake before transporting. Make sure that you remove the key as the fuel pump may run and cause the battery to lose charge.

Using the Motion-Control Levers

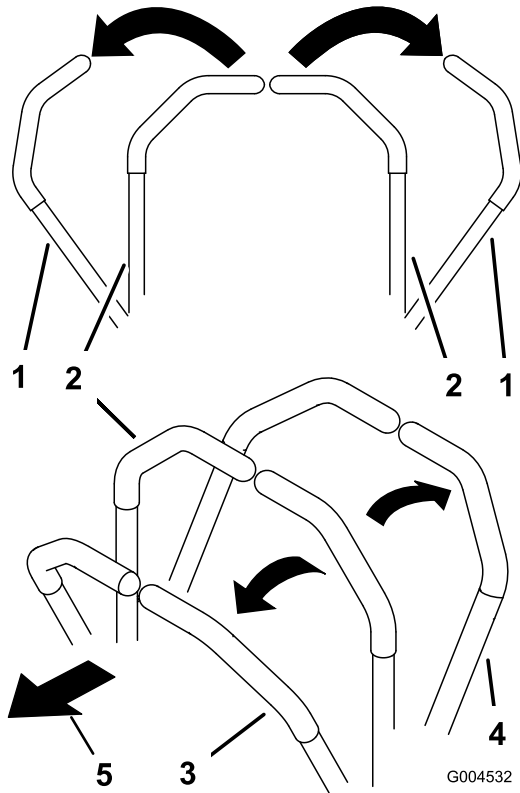

Figure 25

- | | |
|---|---------------------|
| 1. Motion-control lever—NEUTRAL-LOCK position | 4. Backward |
| 2. Center, unlocked position | 5. Front of machine |
| 3. Forward | |

Driving the Machine

The drive wheels turn independently, powered by hydraulic motors on each axle. You can turn 1 side in reverse while you turn the other forward, causing the machine to spin rather than turn. This greatly improves the machine maneuverability but may require some time for you to adapt to how it moves.

The throttle control regulates the engine speed as measured in rpm (revolutions per minute). Place the throttle control in the FAST position for best performance. Always operate in the full throttle position when mowing.

⚠ WARNING

The machine can spin very rapidly. You may lose control of the machine and cause personal injury or damage to the machine.

- Use caution when making turns.
- Slow the machine down before making sharp turns.

Driving Forward

Note: The engine shuts off when you move the traction-control with the parking brake engaged.

To stop the machine, pull the motion-control levers to the NEUTRAL position.

1. Disengage the parking brake; refer to [Disengaging the Parking Brake \(page 28\)](#).
2. Move the levers to the center, unlocked position.
3. To go forward, slowly push the motion-control levers forward ([Figure 26](#)).

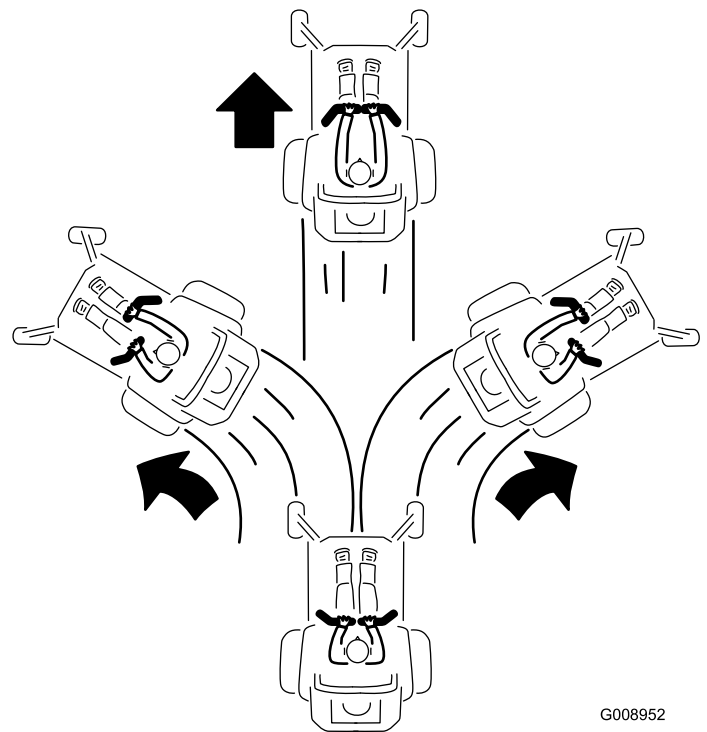
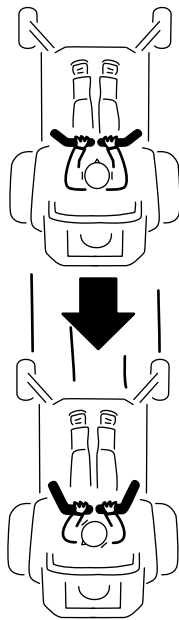

Figure 26

Driving Backward

1. Move the levers to the center, unlocked position.
2. To go backward, slowly pull the motion-control levers rearward ([Figure 27](#)).



G008953

g008953

Figure 27

Using the Side Discharge Machines with Side Discharge Only

The mower has a hinged grass deflector that disperses clippings to the side and down toward the turf.

⚠ DANGER

Without a grass deflector, discharge cover, or a complete grass-catcher assembly mounted in place, you and others are exposed to blade contact and thrown debris. Contact with rotating mower blade(s) and thrown debris will cause injury or death.

- **Never remove the grass deflector from the mower deck because the grass deflector routes material down toward the turf. If the grass deflector is ever damaged, replace it immediately.**
- **Never put your hands or feet under the mower deck.**
- **Never try to clear the discharge area or mower blades unless you move the blade-control switch (PTO) to the OFF position, rotate the key switch to the OFF position, and remove the key from the key switch.**
- **Make sure that the grass deflector is in the down position.**

Adjusting the Height of Cut

Using the Transport Lock

The transport lock has 2 positions, and is used with the deck-lift pedal. There is a LOCK position and an UNLOCK position for the transport position of the mower deck (Figure 28).

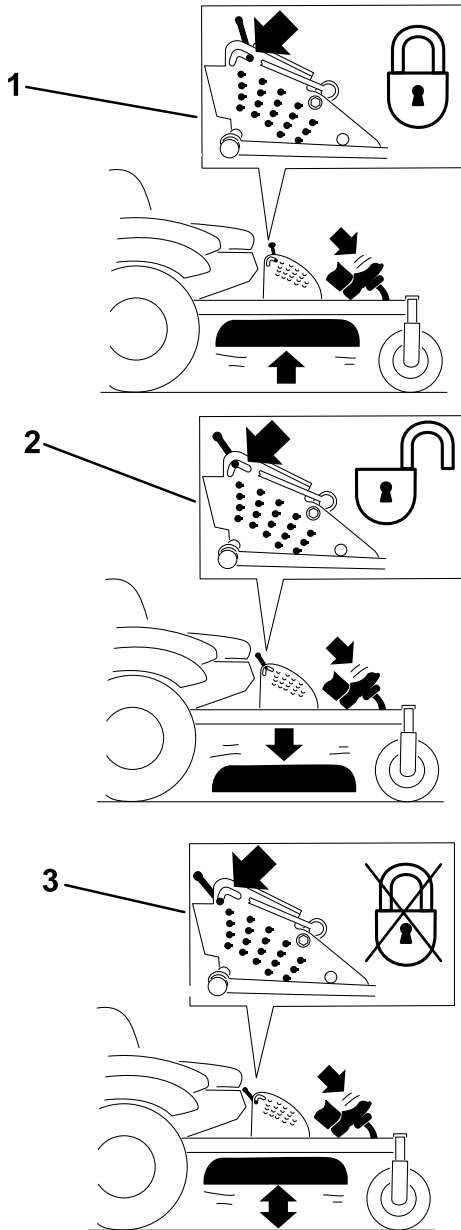

Figure 28

Transport-Lock Positions

1. Transport lock knob
2. LOCK position—The mower deck locks into the transport position.
3. UNLOCK position—The mower deck does not lock into the transport position.

Adjusting the Height-of-Cut Pin

The height-of-cut is adjusted from 25 to 140 mm (1 to 5-1/2 inches) in 6 mm (1/4 inch) increments by relocating the clevis pin into different hole locations.

1. Move the transport lock to the lock position.
2. Push on the deck-lift pedal with your foot, and raise the mower deck to the transport position (also the 140 mm (5-1/2 inch) cutting height position) as shown in Figure 29.
3. To adjust, rotate the pin 90 degrees and remove the pin from the height-of-cut bracket (Figure 29).
4. Select a hole in the height-of-cut bracket corresponding to the height-of-cut desired, and insert the pin (Figure 29).
5. Push on the deck lift, pull back on the transport lock, and slowly lower the mower deck.

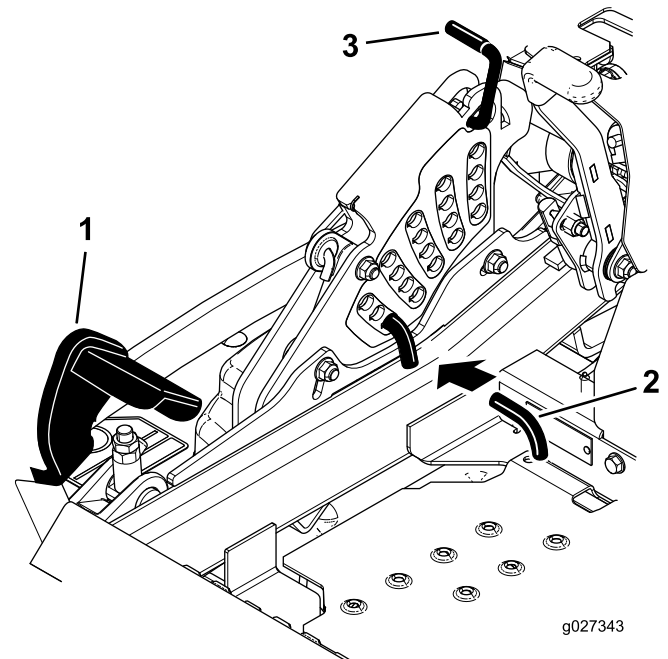

Figure 29

1. Deck-lift pedal
2. Cut-of-height pin
3. Transport lock

Adjusting the Anti-Scalp Rollers

Machines with Side Discharge

Whenever you change the height-of-cut, adjust the height of the anti-scalp rollers.

1. Park the machine on a level surface, disengage the blade-control switch, and engage the parking brake.
2. Shut off the engine, remove the key, and wait for all moving parts to stop before leaving the operating position.
3. Adjust the anti-scalp rollers as shown in [Figure 30](#), [Figure 31](#), and [Figure 32](#).

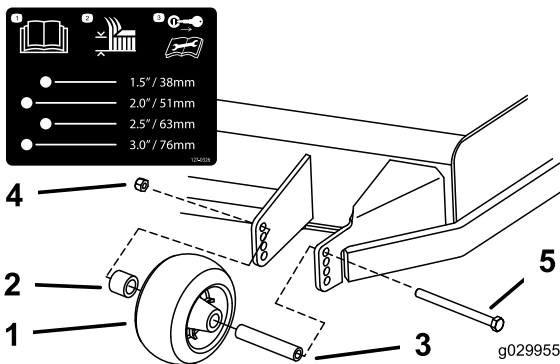

Figure 30

- | | |
|----------------------|---------------|
| 1. Anti-scalp roller | 4. Flange nut |
| 2. Spacer | 5. Bolt |
| 3. Bushing | |

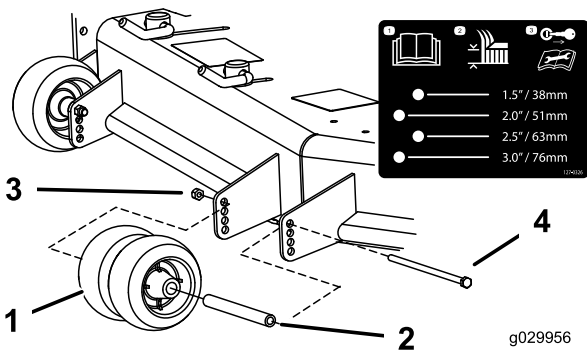

Figure 31

- | | |
|----------------------|---------------|
| 1. Anti-scalp roller | 3. Flange nut |
| 2. Bushing | 4. Bolt |

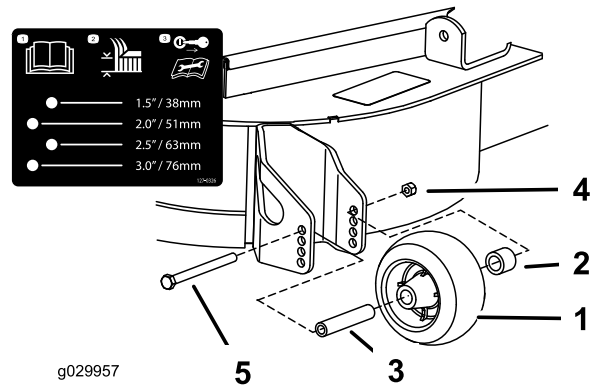

Figure 32

- | | |
|----------------------|---------------|
| 1. Anti-scalp roller | 4. Flange nut |
| 2. Spacer | 5. Bolt |
| 3. Bushing | |

Machines with Rear Discharge

Whenever you change the height of cut, it is recommended to adjust the height of the anti-scalp rollers.

1. Park the machine on a level surface, disengage the blade-control switch, and engage the parking brake.
2. Shut off the engine, remove the key, and wait for all moving parts to stop before leaving the operating position.
3. Adjust the anti-scalp rollers as shown in [Figure 33](#) and [Figure 34](#).

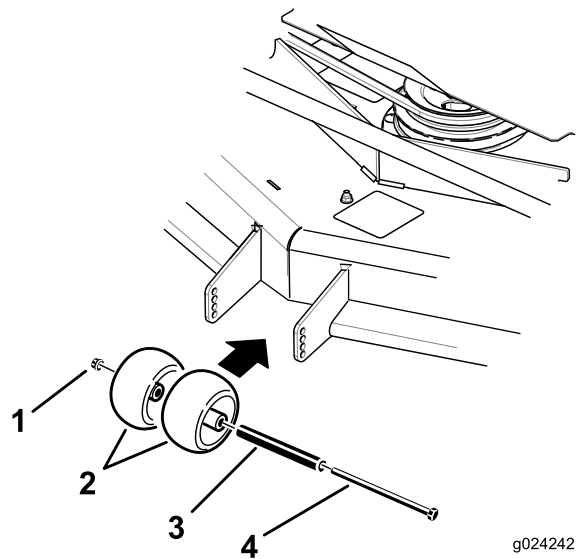

Figure 33

- | | |
|----------------------|------------|
| 1. Flange nut | 3. Bushing |
| 2. Anti-scalp roller | 4. Bolt |

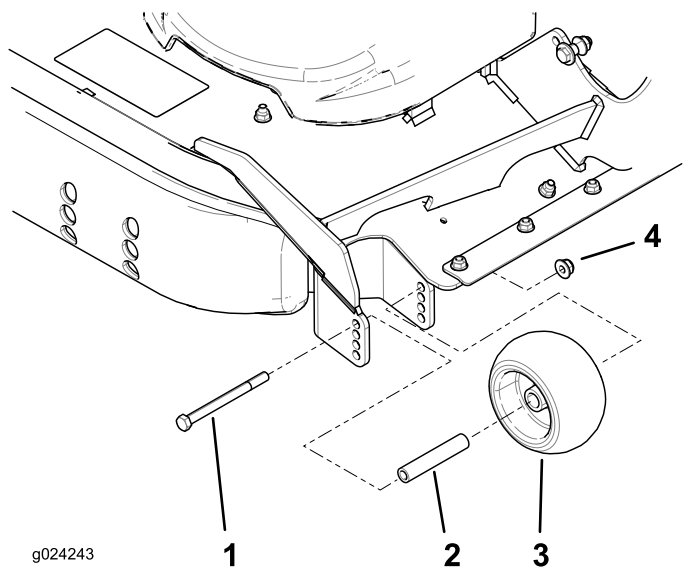

Figure 34

- | | |
|------------|----------------------|
| 1. Bolt | 3. Anti-scalp roller |
| 2. Bushing | 4. Flange nut |

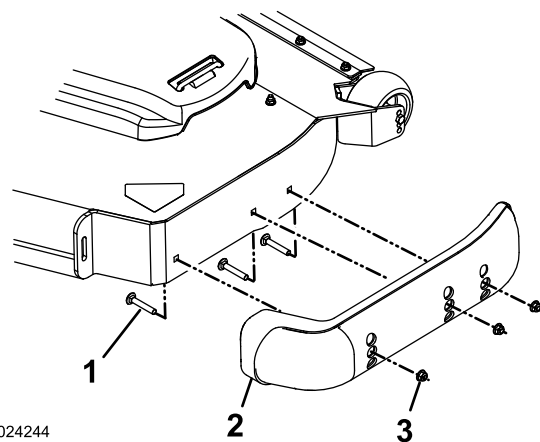

Figure 35

- | | |
|------------------|--------|
| 1. Carriage bolt | 3. Nut |
| 2. Skid | |

Adjusting the Skid(s) For Machines with Rear Discharge

Mount the skids in the lower position when operating in height of cuts higher than 64 mm (2-1/2 inches) and in the higher position when operating in height of cuts lower than 64 mm (2-1/2 inches).

Note: When the skids become worn, switch the skid to the opposite sides of the mower, flipping them over. This allows you to use the skids longer before replacing them.

1. Park the machine on a level surface, disengage the blade-control switch, and engage the parking brake.
2. Shut off the engine, remove the key, and wait for all moving parts to stop before leaving the operating position.
3. Remove the carriage bolts and nuts from each skid (Figure 35).

4. Move each skid to the desired position and secure them with the carriage bolts and nuts.

Note: Only use the top or center sets of holes to adjust the skids. The bottom holes are used when switching sides on the mower deck, at which time they become the top holes on the other side of the mower.

5. To prevent damaging the skid, torque the carriage bolts and nuts for each skid to 12.4 to 14.7 N·m (110 to 130 in-lb).

Adjusting the Flow Baffle Knob

For Machines with Side Discharge

This procedure is applicable only to machines with the flow baffle knob. Certain models have nuts and bolts in place of the flow-baffle knob and can be adjusted the same.

You can adjust the mower discharge flow for different types of mowing conditions. Position the knob and baffle to give the best quality of cut.

1. Park the machine on a level surface, disengage the blade-control switch, and engage the parking brake.
2. Shut off the engine, remove the key, and wait for all moving parts to stop before leaving the operating position.
3. Loosen the knob.
4. Slide the knob to the desired position.
5. Tighten the knob.

Positioning the Flow Baffle For Machines with Side Discharge

The following figures are only recommendations for use. Adjustments vary by grass type, moisture content, and the height of the grass.

Note: If the engine power draws down and the mower ground speed is the same, open up the baffle.

Position A

This is the fully-rear position. The suggested use for this position is as follows:

- Short, light grass mowing conditions
- Dry conditions
- Smaller grass clippings
- Propels grass clippings farther away from the mower

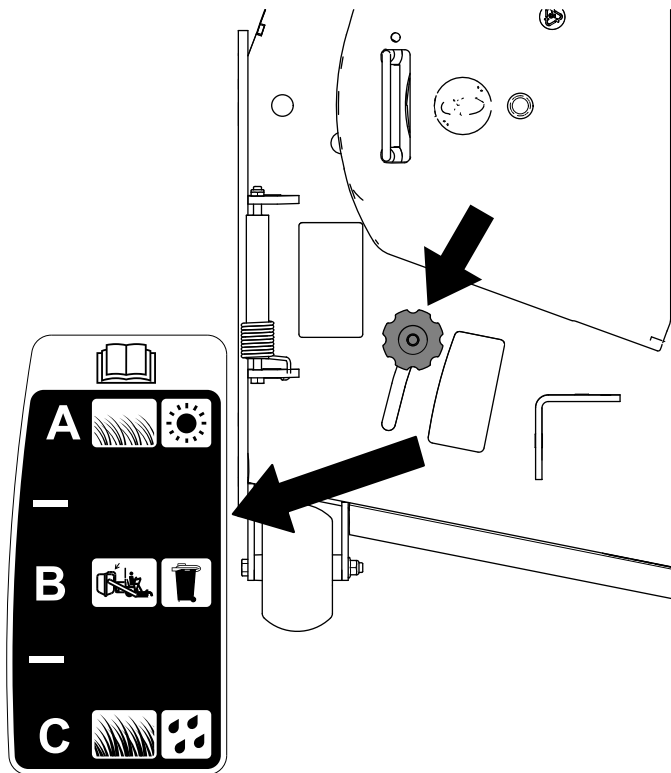

Figure 36

g295810

Position B

Use this position when bagging. Always align it with the blower opening.

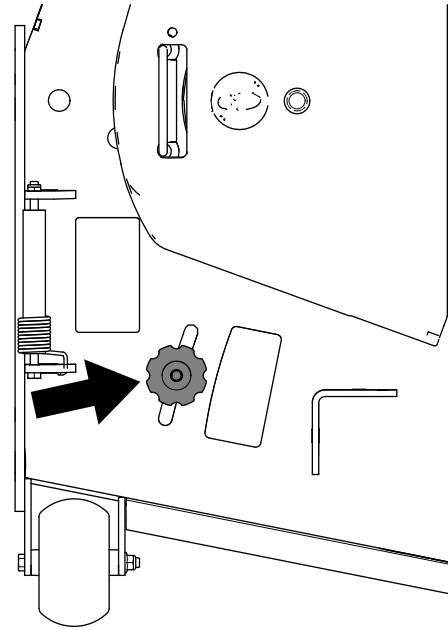

Figure 37

g295811

Position C

This is the fully-forward position. The suggested use for this position is as follows:

- Tall, dense grass mowing conditions
- Wet conditions
- Lowers the engine-power consumption
- Allows increased ground speed in heavy conditions

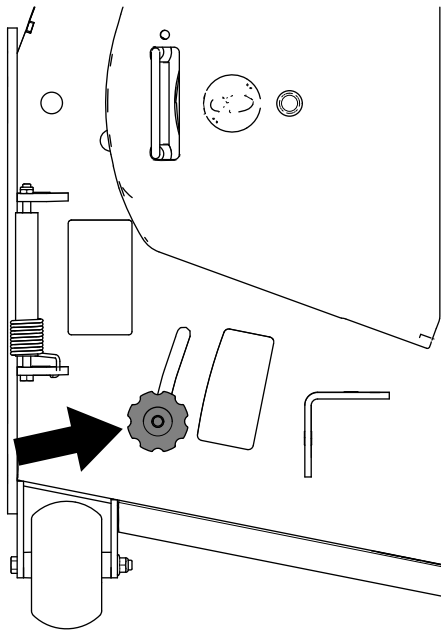

Figure 38

g295812

Mowing at Correct Intervals

Grass grows at different rates at different times of the year. To maintain the same cutting height, mow more often in early spring. As the grass growth rate slows in mid summer, mow less frequently. If you cannot mow for an extended period, first mow at a high cutting height, then mow again 2 days later at a lower height setting.

Using a Slower Cutting Speed

To improve cut quality, use a slower ground speed in certain conditions.

Avoiding Cutting Too Low

When mowing uneven turf, raise the cutting height to avoid scalping the turf.

Operating Tips

Using the Fast Throttle Setting

For best mowing and maximum air circulation, operate the engine at the FAST position. Air is required to thoroughly cut grass clippings, so do not set the height-of-cut so low as to totally surround the mower deck in uncut grass. Always try to have 1 side of the mower deck free from uncut grass, which allows air to be drawn into the mower deck.

Cutting a Lawn for the First Time

Cut grass slightly longer than normal to ensure that the cutting height of the mower deck does not scalp any uneven ground. However, the cutting height used in the past is generally the best one to use. When cutting grass longer than 15 cm (6 inches) tall, you may want to cut the lawn twice to ensure an acceptable quality of cut.

Cutting a Third of the Grass Blade

It is best to cut only about a third of the grass blade. Cutting more than that is not recommended unless grass is sparse, or it is late fall when grass grows more slowly.

Alternating the Mowing Direction

Alternate the mowing direction to keep the grass standing straight. This also helps disperse clippings, which enhances decomposition and fertilization.

Stopping the Machine

If you must stop the forward motion of the machine while mowing, a clump of grass clippings may drop onto your lawn. To avoid this, move onto a previously cut area with the blades engaged or you can disengage the mower deck while moving forward.

Keeping the Underside of the Mower Deck Clean

Clean clippings and dirt from the underside of the mower deck after each use. If grass and dirt build up inside the mower deck, cutting quality will eventually become unsatisfactory.

Maintaining the Blade(s)

Maintain a sharp blade throughout the cutting season because a sharp blade cuts cleanly without tearing or shredding the grass blades. Tearing and shredding turns grass brown at the edges, which slows growth and increases the chance of disease. Check the mower blades after each use for sharpness, and for any wear or damage. File down any nicks and sharpen the blades as necessary. If a blade is damaged or worn, replace it immediately with a genuine Toro replacement blade.

After Operation

After Operation Safety

General Safety

- Park machine on level ground, disengage drives, set parking brake, stop engine, remove key or disconnect spark plug wire. Wait for all movement to stop and allow the machine to cool before adjusting, cleaning, repairing, or storing. Never allow untrained personnel to service machine.
- Clean the machine as stated in the Maintenance section. Keep engine and engine area free from accumulation of grass, leaves, excessive grease or oil, and other debris which can accumulate in these areas. These materials can become combustible and may result in a fire.
- Frequently check for worn or deteriorating components that could create a hazard. Tighten loose hardware.

Using the Fuel-Shutoff Valve

The fuel-shutoff valve is located under the seat. Move the seat forward to access it.

Close the fuel-shutoff valve for transport, maintenance, and storage.

Ensure that the fuel-shutoff valve is open when starting the engine.

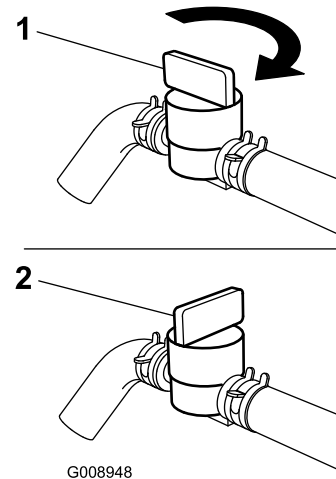

Figure 39

1. ON position

2. OFF position

Using the Drive-Wheel-Release Valves

⚠ WARNING

Hands may become entangled in the rotating drive components below the engine deck, which could result in serious injury.

Shut off the engine, remove the key, and allow all moving parts to stop before accessing the drive-wheel-release valves.

⚠ WARNING

The engine and hydraulic-drive units can become very hot. Touching a hot engine or hydraulic-drive units can cause severe burns.

Allow the engine and hydraulic-drive units to cool completely before accessing the drive-wheel-release valves.

The drive-wheel-release valves are located in the back of each hydraulic-drive unit, under the seat.

Note: Make sure that the release valves are in the fully horizontal position when operating the machine; otherwise, severe damage to the hydraulic system can occur.

1. Park the machine on a level surface, disengage the blade-control switch, and engage the parking brake.
2. Shut off the engine, remove the key, and wait for all moving parts to stop before leaving the operating position.
3. Rotate the release-valve levers vertically to push the machine (Figure 40).

Note: This allows hydraulic fluid to bypass the pump, enabling the wheels to turn.

4. Disengage the parking brake before pushing the machine.

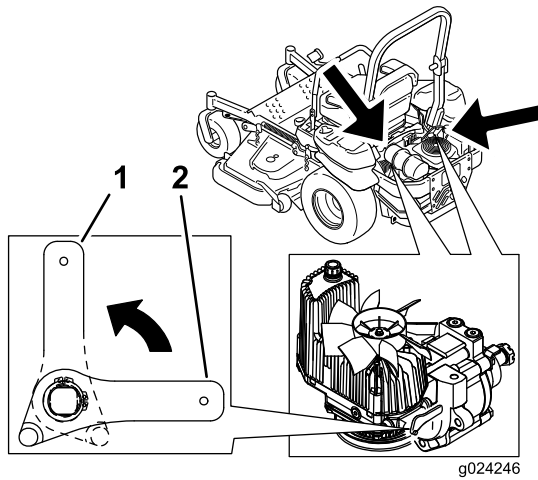

Figure 40

1. Vertical to push the machine
 2. Horizontal to run the machine
-
5. Rotate the release valve levers horizontally to run the machine (Figure 40).

Transporting the Machine

Use a heavy-duty trailer or truck to transport the machine. Use a full-width ramp. Ensure that the trailer or truck has all the necessary brakes, lighting, and marking as required by law. Please carefully read all the safety instructions. Knowing this information could help you or bystanders avoid injury. Refer to your local ordinances for trailer and tie-down requirements.

⚠ WARNING

Driving on the street or roadway without turn signals, lights, reflective markings, or a slow-moving-vehicle emblem is dangerous and can lead to accidents, causing personal injury.

Do not drive the machine on a public street or roadway.

Selecting a Trailer

⚠ WARNING

Loading a machine onto a trailer or truck increases the possibility of tip-over and could cause serious injury or death (Figure 41).

- Use only a full-width ramp; do not use individual ramps for each side of the machine.
- Do not exceed a 15-degree angle between the ramp and the ground or between the ramp and the trailer or truck.
- Ensure that the length of the ramp is at least 4 times as long as the height of the trailer or truck bed to the ground. This ensures that the ramp angle does not exceed 15 degrees on flat ground.

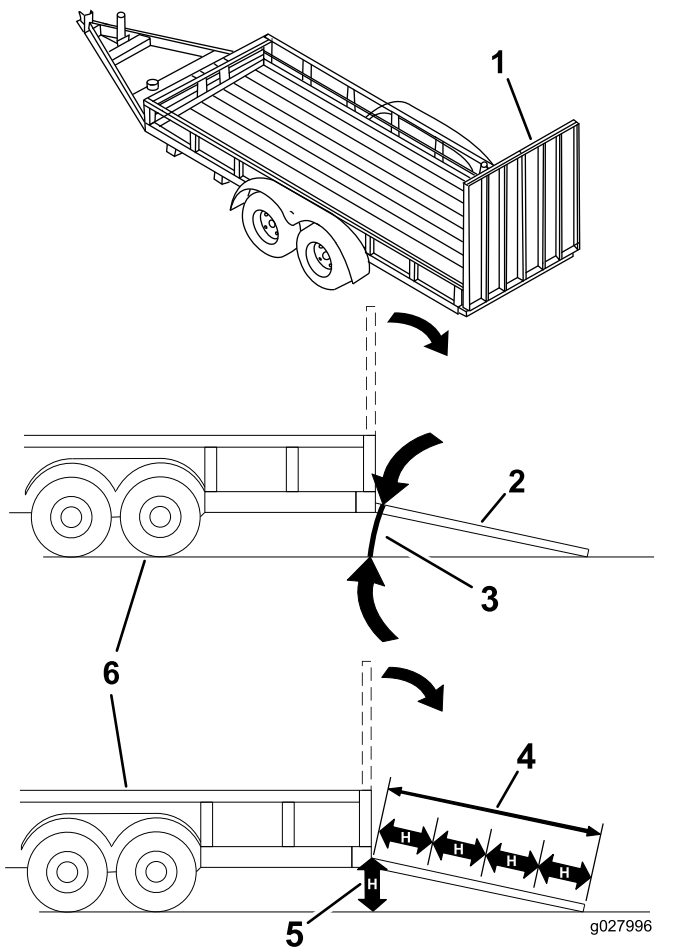

Figure 41

- | | |
|---|---|
| 1. Full-width ramp in stowed position | 4. Ramp is at least 4 times as long as the height of the trailer or truck bed to the ground |
| 2. Side view of full-width ramp in loading position | 5. H=height of the trailer or truck bed to the ground |
| 3. Not greater than 15 degrees | 6. Trailer |

Loading the Machine

⚠ WARNING

Loading a machine onto a trailer or truck increases the possibility of tip-over and could cause serious injury or death.

- Use extreme caution when operating a machine on a ramp.
- Back the machine up the ramp and drive it forward down the ramp.
- Avoid sudden acceleration or deceleration while driving the machine on a ramp as this could cause a loss of control or a tip-over situation.

1. If using a trailer, connect it to the towing vehicle and connect the safety chains.
2. If applicable, connect the trailer brakes and lights.
3. Lower the ramp, ensuring that the angle between the ramp and the ground does not exceed 15 degrees (Figure 41).
4. Back the machine up the ramp (Figure 42).

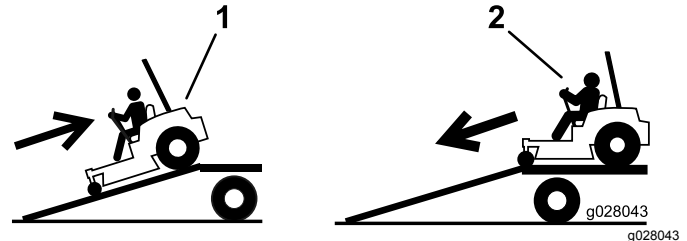

Figure 42

1. Back the machine up the ramp.
2. Drive the machine forward down the ramp.

5. Shut off the engine, remove the key, and engage the parking brake.
6. Tie down the machine near the front caster wheels and the rear bumper with straps, chains, cable, or ropes (Figure 43). Refer to local regulations for tie-down requirements.

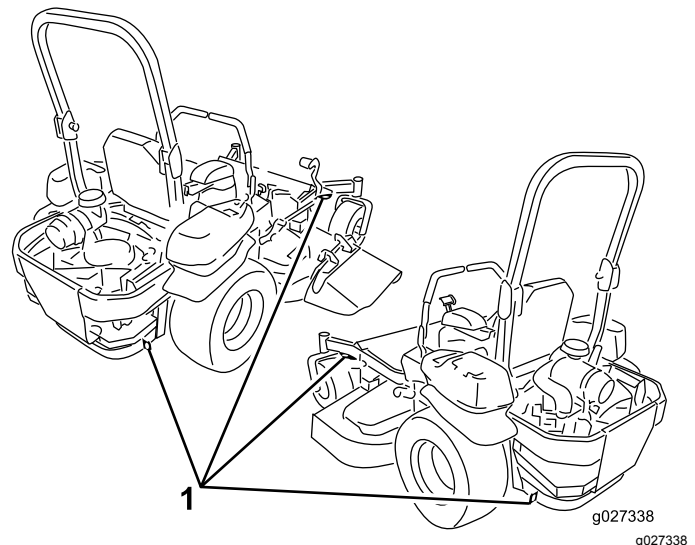

Figure 43

1. Tie-down loops

Unloading the Machine

1. Lower the ramp, ensuring that the angle between the ramp and the ground does not exceed 15 degrees (Figure 41).
2. Drive the machine forward down the ramp (Figure 42).

Maintenance

Maintenance Safety

⚠ WARNING

While maintenance or adjustments are being made, someone could start the engine. Accidental starting of the engine could seriously injure you or other bystanders.

Remove the key from the ignition switch, engage parking brake, and pull the wire(s) off the spark plug(s) before you do any maintenance. Also push the wire(s) aside so it does not accidentally contact the spark plug(s).

⚠ WARNING

The engine can become very hot. Touching a hot engine can cause severe burns.

Allow the engine to cool completely before service or making repairs around the engine area.

- Park machine on level ground, disengage drives, set parking brake, stop engine, remove key or disconnect spark plug wire. Wait for all movement to stop and allow the machine to cool before adjusting, cleaning or repairing. Never allow untrained personnel to service machine.
- Disconnect battery or remove spark plug wire before making any repairs. Disconnect the negative terminal first and the positive last. Reconnect positive first and negative last.
- Keep the machine, guards, shields and all safety devices in place and in safe working condition. Frequently check for worn or deteriorating components and replace them with the manufacturer's recommended parts when necessary.

⚠ WARNING

Removal or modification of original equipment, parts and/or accessories may alter the warranty, controllability, and safety of the machine. Unauthorized modifications to the original equipment or failure to use original Toro parts could lead to serious injury or death. Unauthorized changes to the machine, engine, fuel or venting system, may violate applicable safety standards such as: ANSI, OSHA and NFPA and/or government regulations such as EPA and CARB.

⚠ WARNING

Hydraulic fluid escaping under pressure can penetrate skin and cause injury. Fluid accidentally injected into the skin must be surgically removed within a few hours by a doctor familiar with this form of injury or gangrene may result.

- If equipped, make sure all hydraulic fluid hoses and lines are in good condition and all hydraulic connections and fittings are tight before applying pressure to hydraulic system.
- Keep body and hands away from pinhole leaks or nozzles that eject high pressure hydraulic fluid.
- Use cardboard or paper, not your hands, to find hydraulic leaks.
- Safely relieve all pressure in the hydraulic system by placing the motion control levers in neutral and shutting off the engine before performing any work on the hydraulic system.

⚠ WARNING

Fuel system components are under high pressure. The use of improper components can result in system failure, gasoline leakage and possible explosion.

Use only approved fuel lines and fuel filters for high pressure systems.

- Use care when checking blades. Wrap the blade(s) or wear gloves, and use caution when servicing them. Only replace damaged blades. Never straighten or weld them.

- Use jack stands to support the machine and/or components when required.

⚠ CAUTION

Raising the machine for service or maintenance relying solely on mechanical or hydraulic jacks could be dangerous. The mechanical or hydraulic jacks may not be enough support or may malfunction allowing the machine to fall, which could cause injury.

Do not rely solely on mechanical or hydraulic jacks for support. Use adequate jack stands or equivalent support.

- Carefully release pressure from components with stored energy.

- Keep hands and feet away from moving parts. If possible, Do Not make adjustments with the engine running. If the maintenance or adjustment procedure require the engine to be running and components moving, use extreme caution.

⚠ WARNING

Contact with moving parts or hot surfaces may cause personal injury.

Keep your fingers, hands, and clothing clear of rotating components and hot surfaces.

- Check all bolts frequently to maintain proper tightness.

Recommended Maintenance Schedule(s)

Maintenance Service Interval	Maintenance Procedure
After the first 100 hours	<ul style="list-style-type: none"> • Check the wheel lug-nut torque. • Check the wheel-hub slotted-nut torque. • Check the parking brake adjustment.
After the first 250 hours	<ul style="list-style-type: none"> • Change the hydraulic filters and hydraulic fluid.
Before each use or daily	<ul style="list-style-type: none"> • Check the safety-interlock system. • Check the engine-oil level. • Check the seat belt. • Check the roll bar knobs. • Clean the engine screen and the oil cooler. • Check and clean the hydraulic-unit shrouds. • Inspect the blades. • Clean the mower deck. • Clean the suspension system.
Every 50 hours	<ul style="list-style-type: none"> • Check the spark arrester (if equipped). • Check the tire pressure • Inspect the belts for cracks and wear. • Check the hydraulic-fluid level.
Every 100 hours	<ul style="list-style-type: none"> • Lubricate the mower deck-lift pivots. • Change the engine oil (more often in dirty or dusty conditions). • Check and clean engine-cooling fins and shrouds.
Every 150 hours	<ul style="list-style-type: none"> • Inspect the primary filter (more often in dirty or dusty conditions).
Every 200 hours	<ul style="list-style-type: none"> • Change the engine-oil filter (more often in dirty or dusty conditions). • Check the spark plug(s). • Replace the fuel filter (more often in dirty or dusty conditions).
Every 250 hours	<ul style="list-style-type: none"> • After the initial change—change the hydraulic-system filters and fluid when using Mobil 1 15W50 fluid. (Change it more often under dirty or dusty conditions)
Every 300 hours	<ul style="list-style-type: none"> • Replace the primary air filter (more often in dirty or dusty conditions). • Check the inner air filter (more often in dirty or dusty conditions).
Every 400 hours	<ul style="list-style-type: none"> • Grease the caster pivots (more often in dirty or dusty conditions).

Maintenance Service Interval	Maintenance Procedure
Every 500 hours	<ul style="list-style-type: none"> • Replace the spark plug(s). • Check the wheel lug-nut torque. • Check the wheel-hub slotted-nut torque. • Adjust the caster-pivot bearing. • Check the parking brake adjustment. • After the initial change—change the hydraulic-system filters and fluid when using Toro® HYPR-OIL™ 500 fluid. (Change it more often under dirty or dusty conditions)
Every 600 hours	<ul style="list-style-type: none"> • Replace the inner air filter.
Monthly	<ul style="list-style-type: none"> • Check the battery charge.
Yearly	<ul style="list-style-type: none"> • Grease the pump-belt-idler arm. • Repack the caster-wheel bearings (more often in dirty or dusty conditions). • Greasing the caster-wheel hubs.
Yearly or before storage	<ul style="list-style-type: none"> • Paint chipped surfaces. • Check all maintenance procedures listed above before storage.

Important: Refer to your engine owner's manual for additional maintenance procedures.

▲ CAUTION

If you leave the key in the switch, someone could accidentally start the engine and seriously injure you or other bystanders.

Shut off the engine and remove the key from the switch before you perform any maintenance.

Lubrication

Greasing the Machine

Grease the machine more often in dirty or dusty conditions.

Grease Type: No. 2 lithium or molybdenum grease

1. Park the machine on a level surface, disengage the blade-control switch, and engage the parking brake.
2. Shut off the engine, remove the key, and wait for all moving parts to stop before leaving the operating position.

3. Clean the grease fittings with a rag.

Note: Scrape any paint off the front of the fitting(s).

4. Connect a grease gun to the fitting.
5. Pump grease into the fittings until grease begins to ooze out of the bearings.
6. Wipe up any excess grease.

Lubricating the Mower Deck-Lift Pivots

Service Interval: Every 100 hours

Use light oil or spray lubricant to lubricate the deck-lift pivots.

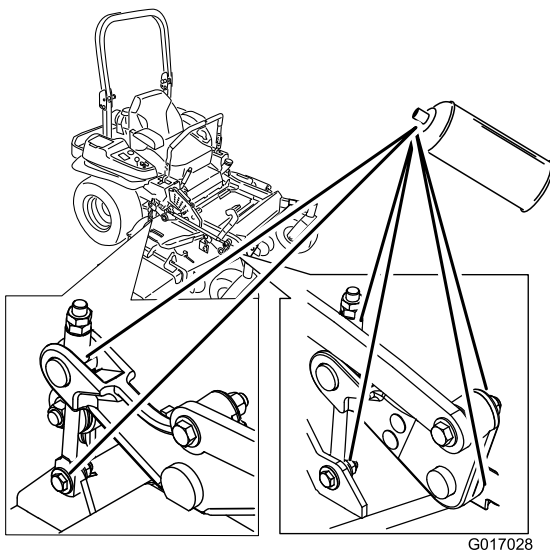

Figure 44

Machine with Side Discharge Shown

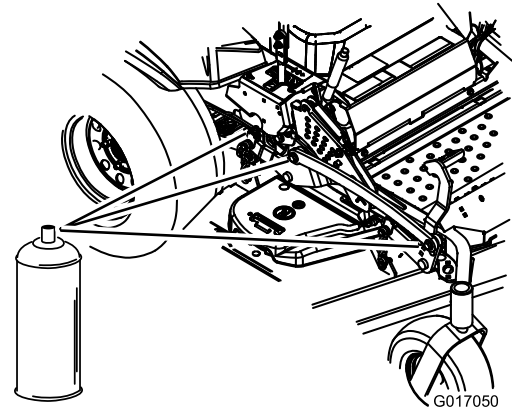

Figure 45

g017050

Greasing the Mower Deck

Service Interval: Yearly—Grease the pump-belt-idler arm.

1. Park the machine on a level surface, disengage the blade-control switch, and engage the parking brake.
2. Shut off the engine, remove the key, and wait for all moving parts to stop before leaving the operating position.
3. Grease the mower deck idler-pulley pivot until grease comes out the bottom ([Figure 46](#) or [Figure 47](#)).

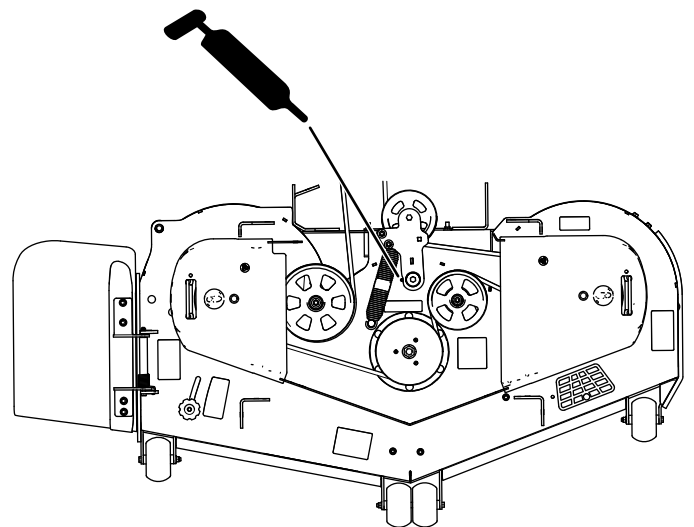

Figure 46

Machine with Side Discharge Shown

g295792

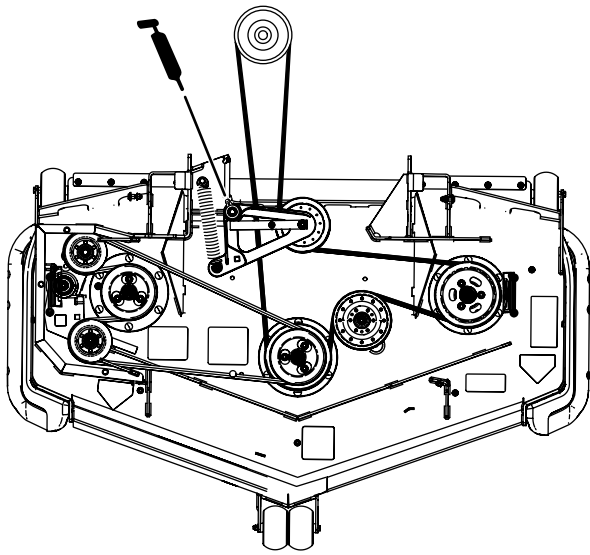

Figure 47

Machine with Rear Discharge Shown

g192516

4. Grease the drive-belt idler arms (Figure 48).

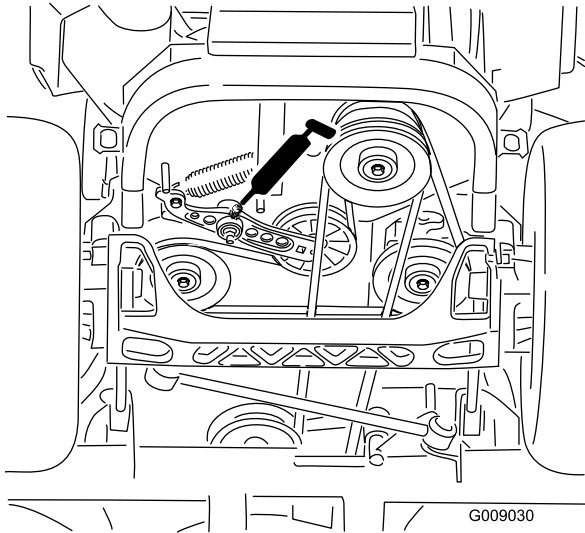

Figure 48

G009030

g009030

5. Grease the deck-belt idler arms (rear discharge machines only) as shown in Figure 49.

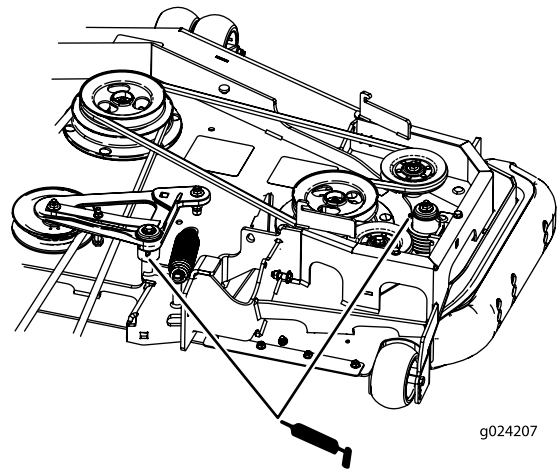

Figure 49

Machines with Rear Discharge Only

g024207

g024207

6. Remove the dust cap and adjust the caster pivots.

Note: Keep the dust cap off until greasing is done.

7. Remove the hex plug.
8. Thread a grease fitting into the hole.
9. Pump grease into the fitting until it oozes out around the top bearing.
10. Remove the grease fitting in the hole.
11. Install the hex plug and dust cap (Figure 50).

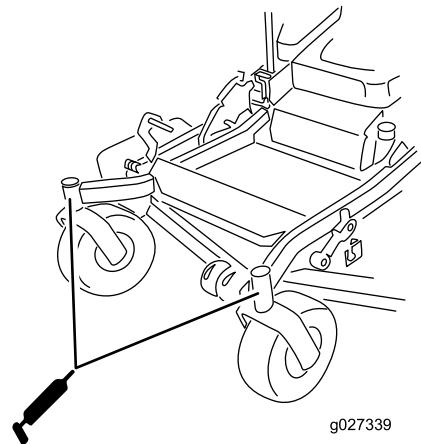

Figure 50

g027339

g027339

12. Grease the caster-wheel bearings (Figure 50).

Greasing the Caster Pivots

Service Interval: Every 400 hours/Yearly (whichever comes first) (more often in dirty or dusty conditions).

Yearly—Repack the caster-wheel bearings (more often in dirty or dusty conditions).

1. Park the machine on a level surface, disengage the blade-control switch, and engage the parking brake.
2. Shut off the engine, remove the key, and wait for all moving parts to stop before leaving the operating position.
3. Remove the dust cap and adjust the caster pivots and keep the dust cap off until greasing is done; refer to [Greasing the Mower Deck \(page 43\)](#).
4. Remove the hex plug.
5. Thread a grease fitting into the hole.
6. Pump grease into the fitting until it oozes out around the top bearing.
7. Remove the grease fitting from the hole. Install the hex plug and cap.

Greasing the Caster-Wheel Hubs

Service Interval: Yearly

1. Park the machine on a level surface, disengage the blade-control switch, and engage the parking brake.
2. Shut off the engine, remove the key, and wait for all moving parts to stop before leaving the operating position.
3. Raise the mower for access.
4. Remove the caster wheel from the caster forks.
5. Remove the seal guards from the wheel hub.

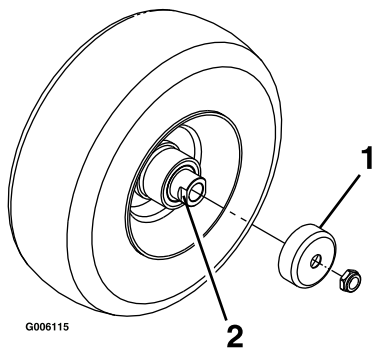

Figure 51

1. Seal guard
2. Spacer nut with wrench flats

6. Remove a spacer nut from the axle assembly in the caster wheel.

Note: Thread-locking compound has been applied to lock the spacer nuts to the axle.

7. Remove the axle (with the other spacer nut still assembled to it) from the wheel assembly.
8. Pry out seals and inspect bearings for wear or damage and replace if necessary.
9. Pack the bearings with a general-purpose grease.
10. Insert 1 bearing and 1 new seal into the wheel.
11. If the axle assembly is missing both spacer nuts, apply a thread-locking compound to 1 spacer nut and thread it onto the axle with the wrench flats facing outward.

Note: Do not thread the spacer nut all of the way onto the end of the axle. Leave approximately 3 mm (1/8 inch) from the outer surface of the spacer nut to the end of the axle inside the nut.

12. Insert the assembled nut and axle into the wheel on the side with the new seal and bearing.
13. With the open end of the wheel facing up, fill the area inside the wheel around the axle full of general-purpose grease.
14. Insert the second bearing and new seal into the wheel.
15. Apply a thread-locking compound to the second spacer nut, and thread it onto the axle with the wrench flats facing outward.
16. Torque the nut to 8 to 9 N·m (75 to 80 in-lb), loosen the nut, then torque it to 2 to 3 N·m (20 to 25 in-lb).

Note: Make sure that the axle does not extend beyond either nut.

17. Install the seal guards over the wheel hub, and insert the wheel into the caster fork.
18. Install the caster bolt and tighten the nut fully.

Important: To prevent seal and bearing damage, check the bearing adjustment often. Spin the caster tire. The tire should not spin freely (more than 1 or 2 revolutions) or have any side play. If the wheel spins freely, adjust the torque on the spacer nut until there is a slight amount of drag. Apply another layer of thread-locking compound.

Engine Maintenance

Engine Safety

- Shut off the engine before checking the oil or adding oil to the crankcase.
- Keep your hands, feet, face, clothing, and other body parts away from the muffler and other hot surfaces.

Servicing the Air Cleaner

Service Interval: Every 150 hours—Inspect the primary filter (more often in dirty or dusty conditions).

Every 300 hours/Yearly (whichever comes first)—Replace the primary air filter (more often in dirty or dusty conditions).

Every 300 hours—Check the inner air filter (more often in dirty or dusty conditions).

Every 600 hours—Replace the inner air filter.

Removing the Filters

1. Park the machine on a level surface, disengage the blade-control switch (PTO), and engage the parking brake.
2. Shut off the engine, remove the key, and wait for all moving parts to stop before leaving the operating position.
3. Release the latches on the air cleaner and pull the air-inlet cover off the air-cleaner body (Figure 52).
4. Clean the air-inlet screen and cover.
5. Install the air-inlet cover and secure it with the latches (Figure 52).

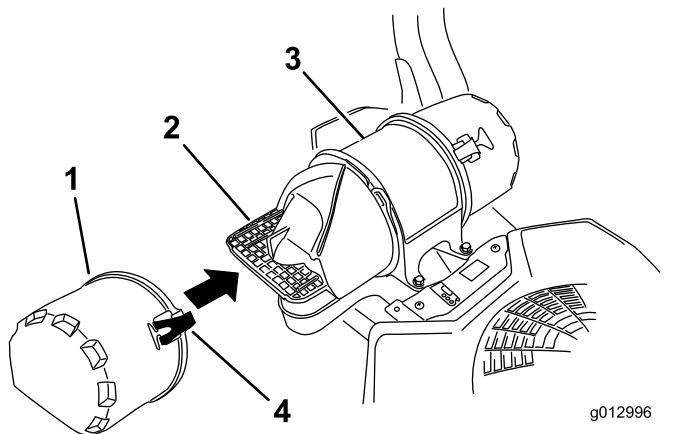

Figure 52

1. Air-inlet cover
2. Air-inlet screen
3. Air-cleaner body
4. Latch

6. Release the latches on the air cleaner and pull the air-cleaner cover off the air-cleaner body (Figure 53).
7. Clean the inside of the air-cleaner cover with compressed air.
8. Gently slide the primary filter out of the air-cleaner body (Figure 53).

Note: Avoid knocking the filter into the side of the body.

9. Remove the inner filter only if you intend to replace it.

Important: Never attempt to clean the inner filter. If the safety filter is dirty, then the primary filter is damaged. Replace both filters.

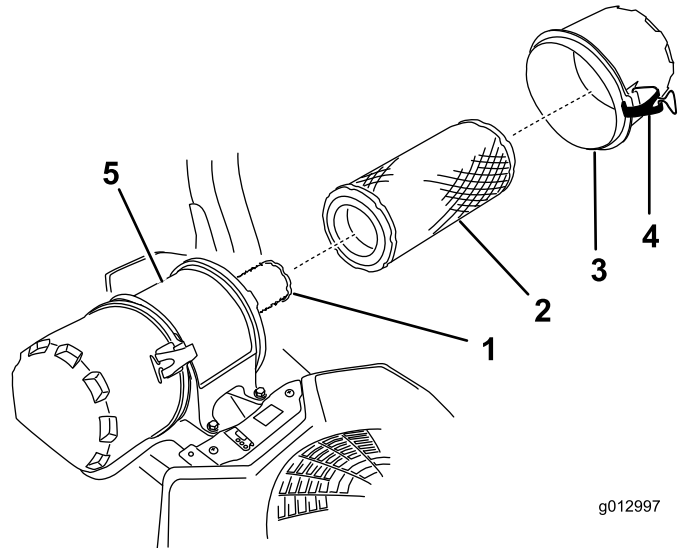

Figure 53

1. Inner filter
2. Primary filter
3. Air-cleaner cover
4. Latch
5. Air-cleaner body

10. Inspect the primary filter for damage by looking into the filter, while shining a bright light on the outside of the filter.

Note: Holes in the filter will appear as bright spots. If the filter is damaged, discard it.

Inspecting the Filters

1. Inspect the inner filter. If it is dirty, replace both the inner and primary filters.

Important: Do not attempt to clean the inner filter. If the inner filter is dirty, then the primary filter is damaged.

- Inspect the primary filter for damage by looking into the filter while shining a bright light on the outside of the filter. If the primary filter is dirty, bent, or damaged, replace it.

Note: Holes in the filter appear as bright spots. Do not clean the primary filter.

Installing the Filters

Important: To prevent engine damage, always operate the engine with both air filters and the cover installed.

- If you are installing new filters, check each filter for shipping damage.

Note: Do not use a damaged filter.

- If you are replacing the safety filter, carefully slide it into the filter body (Figure 53).
- Carefully slide the primary filter over the safety filter (Figure 53).

Note: Ensure that the primary filter is fully seated by pushing on the outer rim while installing it.

Important: Do not press on the soft, inside area of the filter.

- Install the air-cleaner cover and secure the latches (Figure 53).

Servicing the Engine Oil

Service Interval: Before each use or daily

Every 100 hours (more often in dirty or dusty conditions).

Every 200 hours—Change the engine-oil filter (more often in dirty or dusty conditions).

Engine-Oil Specifications

Oil Type: Detergent oil (API service SJ or higher)

Oil Capacity: 1.9 L (64 fl oz) with a filter change; 1.6 L (54 fl oz) without a filter change

Viscosity: See the table below.

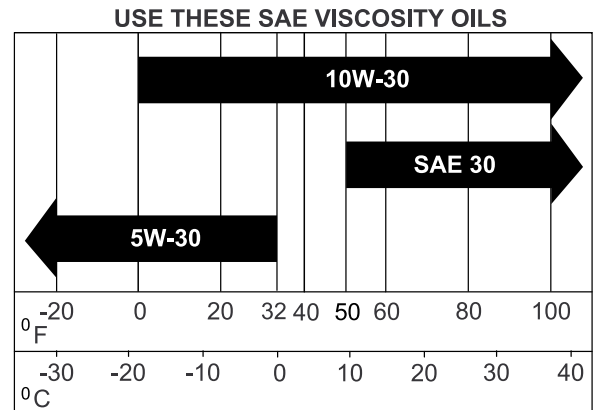

g017552

g017552

Figure 54

Checking the Engine-Oil Level

Note: Check the oil when the engine is cold.

Important: If you overfill or underfill the engine crankcase with oil and run the engine, you may damage the engine.

- Park the machine on a level surface, disengage the blade-control switch (PTO), and engage the parking brake.
- Shut off the engine, remove the key, and wait for all moving parts to stop before leaving the operating position.

Note: Ensure that the engine is cool so that the oil has had time to drain into the sump.

- To keep dirt, grass clippings, etc., out of the engine, clean the area around the oil-fill cap and dipstick before removing it (Figure 55).

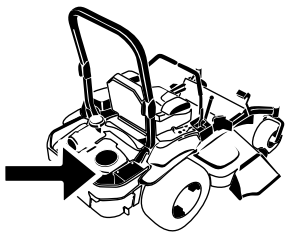

G008804
g008804

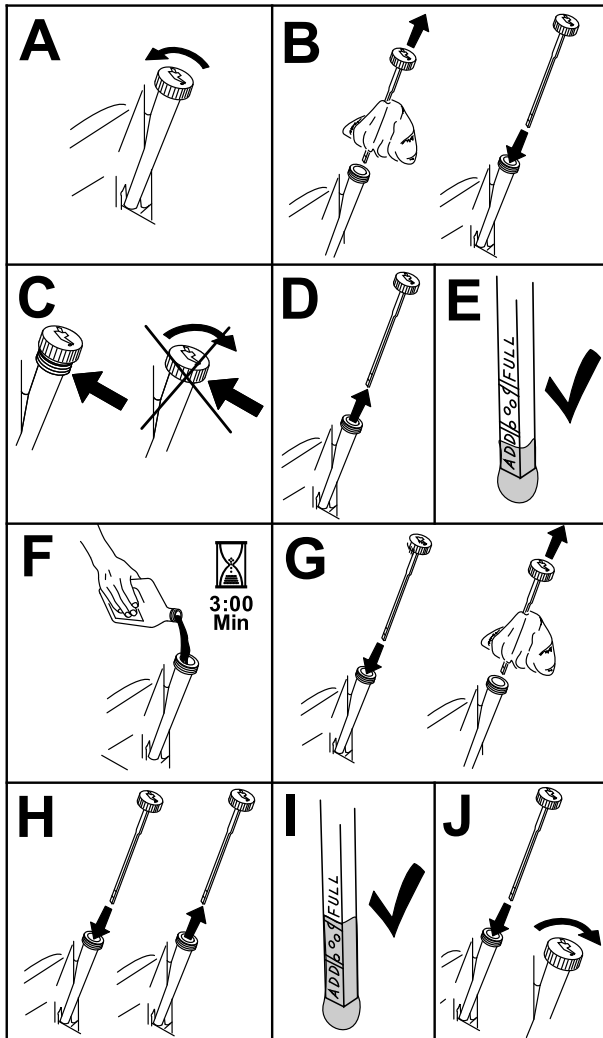
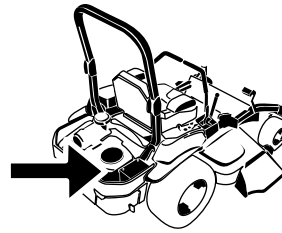

Figure 55

g194611

4. Shut off the engine, remove the key, and wait for all moving parts to stop before leaving the operating position.
5. Drain the oil from the engine (Figure 56).



G008804
g008804

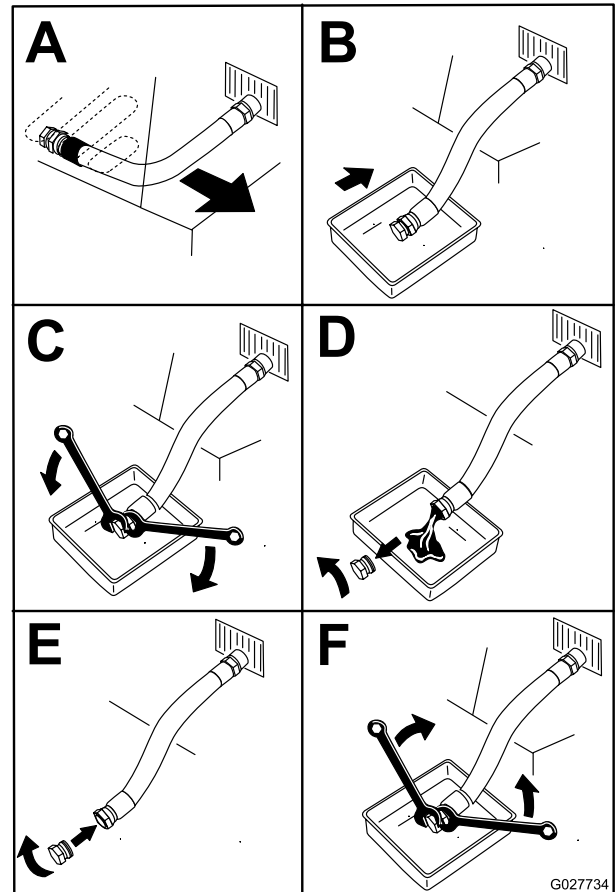

Figure 56

g027734

Changing the Engine Oil

Note: Dispose of the used oil at a recycling center.

1. Start the engine and let it run for 5 minutes.
 - Note:** This warms the oil so that it drains better.
2. Park the machine so that the drain side is slightly lower than the opposite side to ensure that the oil drains completely.
3. Disengage the blade-control switch (PTO) and engage the parking brake.

- Slowly pour approximately 80% of the specified oil into the filler tube and slowly add the additional oil to bring it to the Full mark (Figure 57).

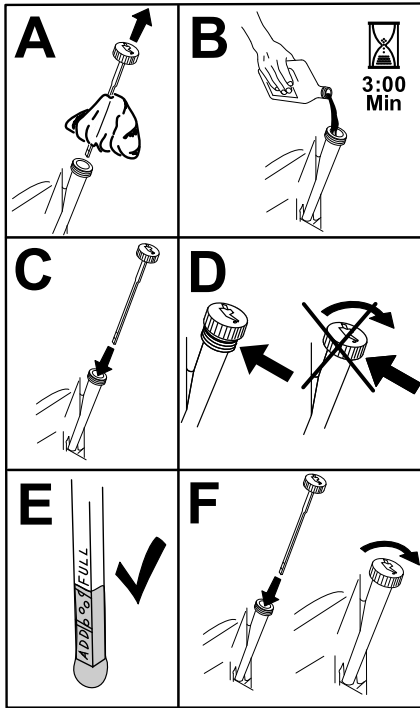

Figure 57

g194610

- Start the engine and drive to a flat area.
- Check the oil level again.

Changing the Engine-Oil Filter

- Drain the oil from the engine; refer to [Changing the Engine Oil \(page 48\)](#).
- Change the engine-oil filter (Figure 58).

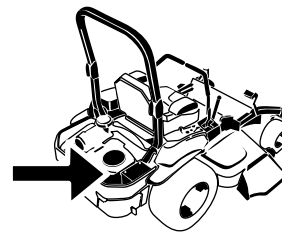

G008804
g008804

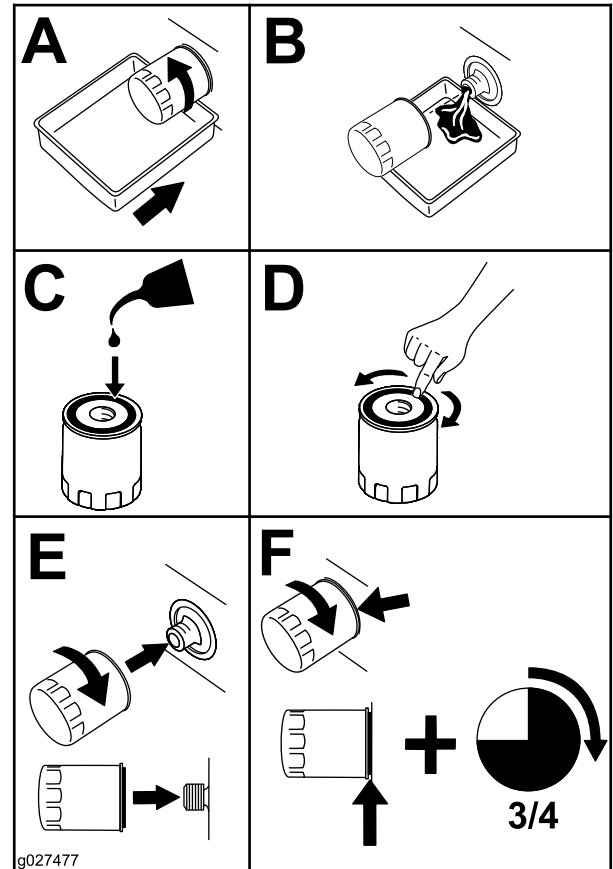

g027477

g027477

Figure 58

Note: Ensure that the oil-filter gasket touches the engine, and then turn the oil filter an extra 3/4 turn.

- Fill the crankcase with the proper type of new oil; refer to [Engine-Oil Specifications \(page 47\)](#).

Servicing the Spark Plug(s)

Service Interval: Every 200 hours—Check the spark plug(s).
Every 500 hours—Replace the spark plug(s).

Type: Champion XC12YC

Air Gap: 0.76 mm (0.03 inch)

Removing the Spark Plug(s)

1. Shut off the engine, remove the key, and wait for all moving parts to stop before leaving the operating position.
2. Disengage the PTO, move the motion-control levers to the NEUTRAL-LOCK position, and engage the parking brake.
3. Remove the left hydraulic-unit shroud in the order listed with [Figure 59](#). This gives you access to the front spark plug.

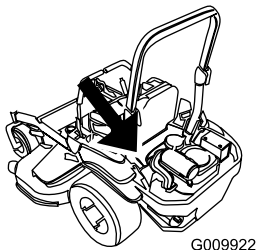

G009922

g009922

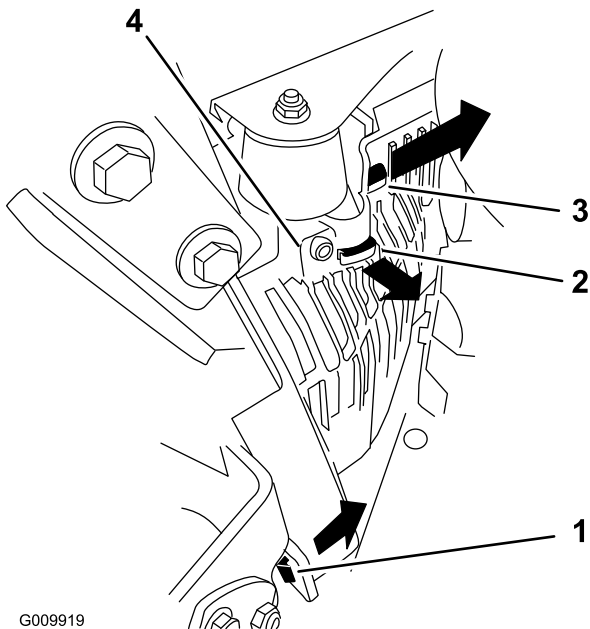

G009919

g009919

Figure 59

1. Pull this tab out to the side in the direction of the arrow
2. Pull the shroud off this frame tab in the direction of the arrow
3. Pull the shroud off this frame tab in the direction of the arrow
4. Shroud

4. Remove the spark plug.



G008803

g008803

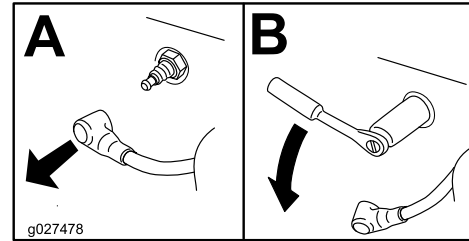

g027478

g027478

Figure 60

Checking the Spark Plug(s)

Important: Do not clean the spark plug(s). Always replace the spark plug(s) when it has a black coating, worn electrodes, an oily film, or cracks.

If you see light brown or gray on the insulator, the engine is operating properly. A black coating on the insulator usually means the air cleaner is dirty.

Set the gap to 0.76 mm (0.03 inch).

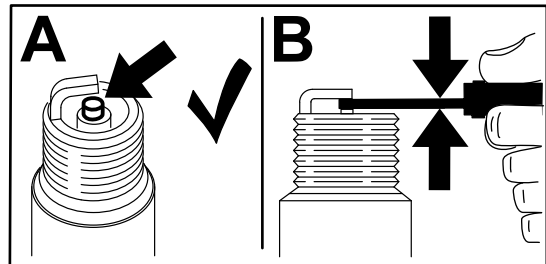

g206628

Figure 61

Installing the Spark Plug(s)

1. Install the spark plug(s) as shown in [Figure 62](#).
2. Install the hydraulic shroud ([Figure 59](#)).

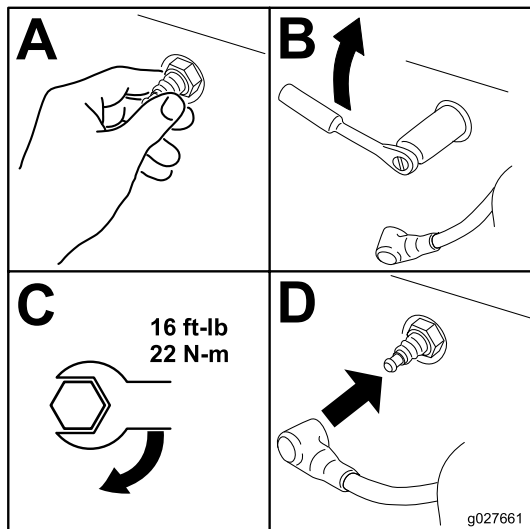

Figure 62

g027661

Fuel System Maintenance

⚠ WARNING

Fuel-system components are under high pressure. The use of improper components can result in system failure, fuel leakage, and possible explosion.

Use only approved fuel lines and fuel filters.

Servicing the Electronic Fuel-Injection System

This machine contains an electronic fuel-injection system. It controls the fuel flow under different operating conditions.

The electronic-control unit (ECU) continuously monitors the operation of the EFI system.

If a problem or fault within the system is detected, the LED status light illuminates. The MIL is the red light located on the right side of the hour meter.

Once the light illuminates, make initial troubleshooting checks; refer to the LED status light section under [LED Status Light \(page 16\)](#).

If these checks do not correct the problem, further diagnosis and servicing by an Authorized Service Dealer is necessary.

Replacing the Low-Pressure Fuel Filter

Service Interval: Every 200 hours/Yearly (whichever comes first)

The fuel filter is located near the engine on the front or rear side of the engine.

1. Park the machine on a level surface, disengage the blade-control switch, and engage the parking brake.
2. Shut off the engine, remove the key, and wait for all moving parts to stop before leaving the operating position.
3. Wait for the machine to cool down.
4. Close the fuel-shutoff valve under the seat ([Figure 63](#)).

Checking the Spark Arrester

For Machines with a Spark Arrester

Service Interval: Every 50 hours

⚠ WARNING

Hot exhaust-system components may ignite fuel vapors even after you shut off the engine. Hot particles exhausted during engine operation may ignite flammable materials, resulting in personal injury or property damage.

Do not refuel or run the engine unless the spark arrester is installed.

1. Park the machine on a level surface, disengage the PTO, and engage the parking brake.
2. Shut off the engine, remove the key, and wait for all moving parts to stop before leaving the operating position.
3. Wait for the muffler to cool.
4. If you see any breaks in the screen or welds, replace the arrester.
5. If the screen is plugged, remove the arrester, shake loose particles out of the arrester, and clean the screen with a wire brush (soak the screen in solvent if necessary).
6. Install the arrester on the exhaust outlet.

Electrical System Maintenance

Electrical System Safety

- Disconnect the battery before repairing the machine. Disconnect the negative terminal first and the positive last. Connect the positive terminal first and the negative last.
- Charge the battery in an open, well-ventilated area, away from sparks and flames. Unplug the charger before connecting or disconnecting the battery. Wear protective clothing and use insulated tools.

Servicing the Battery

Service Interval: Monthly

Removing the Battery

⚠ WARNING

Battery terminals or metal tools could short against metal machine components causing sparks. Sparks can cause the battery gasses to explode, resulting in personal injury.

- When removing or installing the battery, do not allow the battery terminals to touch any metal parts of the machine.
- Do not allow metal tools to short between the battery terminals and metal parts of the machine.

⚠ WARNING

Incorrectly removing the cables from battery could damage the machine and cables, causing sparks. Sparks can cause the battery gasses to explode, resulting in personal injury.

- Always disconnect the negative (black) battery cable before disconnecting the positive (red) cable.
- Always connect the positive (red) battery cable before connecting the negative (black) cable.

1. Park the machine on a level surface, disengage the blade-control switch (PTO), and engage the parking brake.

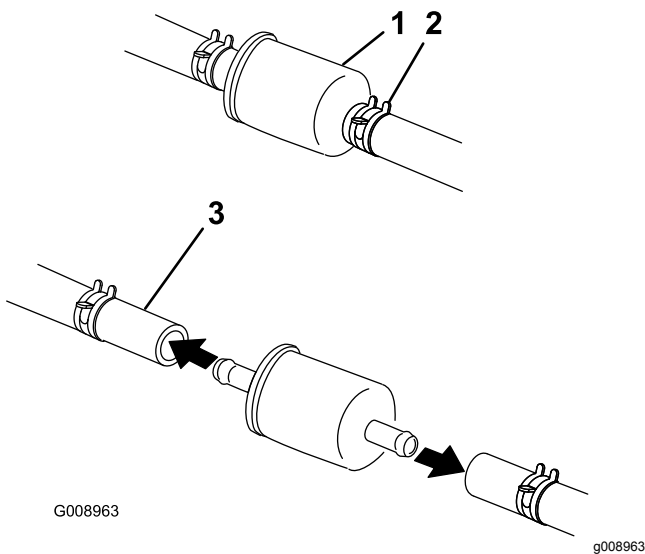

Figure 63

1. Fuel filter
2. Hose clamp
3. Fuel line

5. Squeeze the ends of the hose clamps together and slide them away from the filter (Figure 63).
6. Remove the filter from the fuel lines.
7. Install a new filter and move the hose clamps close to the filter (Figure 63).
8. Open the fuel-shutoff valve.

Important: Install the fuel line hoses and secure with plastic ties the same as they were originally installed at the factory to keep the fuel line away from components that can cause fuel line damage.

Servicing the High-Pressure Fuel Filter

Do not attempt to service the high-pressure fuel filter. The high-pressure filter is integrated within the fuel-pump module. The fuel filter and other components inside the fuel-pump module are not serviceable.

Important: Do not attempt to open the fuel-pump module.

Ensure that an Authorized Service Dealer replaces the fuel-pump module with the high-pressure fuel filter.

Servicing the Fuel Tank

Do not attempt to drain the fuel tank. Ensure that an Authorized Service Dealer drains the fuel tank and services any components of the fuel system.

2. Shut off the engine, remove the key, and wait for all moving parts to stop before leaving the operating position.
3. Remove the battery as shown in [Figure 64](#).

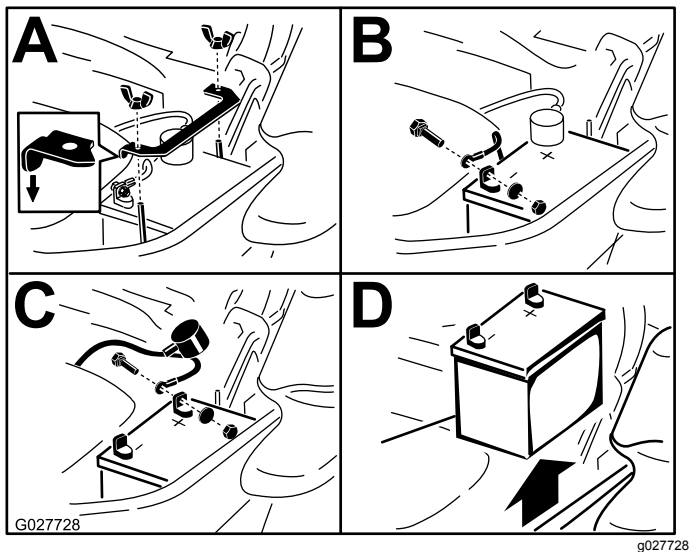

Figure 64

Charging the Battery

⚠ WARNING

Charging the battery produces gasses that can explode.

Never smoke near the battery and keep sparks and flames away from the battery.

Important: Always keep the battery fully charged (1.265 specific gravity). This is especially important to prevent battery damage when the temperature is below 0°C (32°F).

1. Remove the battery from the chassis; refer to [Removing the Battery \(page 52\)](#).
2. Charge the battery for 10 to 15 minutes at 25 to 30 A or for 30 minutes at 10 A.

Note: Do not overcharge the battery.

3. When the battery is fully charged, unplug the charger from the electrical outlet, then disconnect the charger leads from the battery posts ([Figure 65](#)).
4. Install the battery in the machine and connect the battery cables; refer to [Installing the Battery \(page 54\)](#).

Note: Do not run the machine with the battery disconnected; electrical damage may occur.

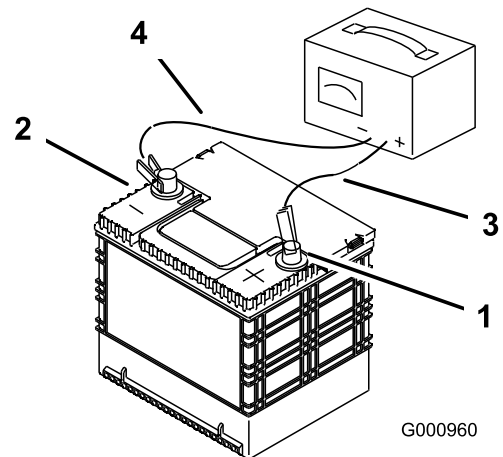

Figure 65

- | | |
|------------------------------|---------------------------|
| 1. Positive (+) battery post | 3. Red (+) charger lead |
| 2. Negative (-) battery post | 4. Black (-) charger lead |

Installing the Battery

Note: Position the battery in the tray with the terminal posts opposite from the hydraulic tank (Figure 66).

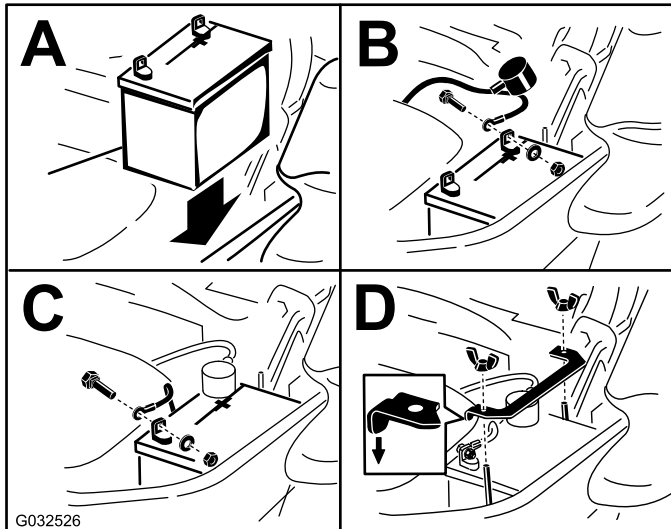

Figure 66

Servicing the Fuses

The electrical system is protected by fuses. It requires no maintenance, however, if a fuse blows check the component/circuit for a malfunction or short. The fuses are located on the console to the right of the seat (Figure 67).

To replace the fuses, remove the cover, pull out on the fuse to remove it, and install a new fuse.

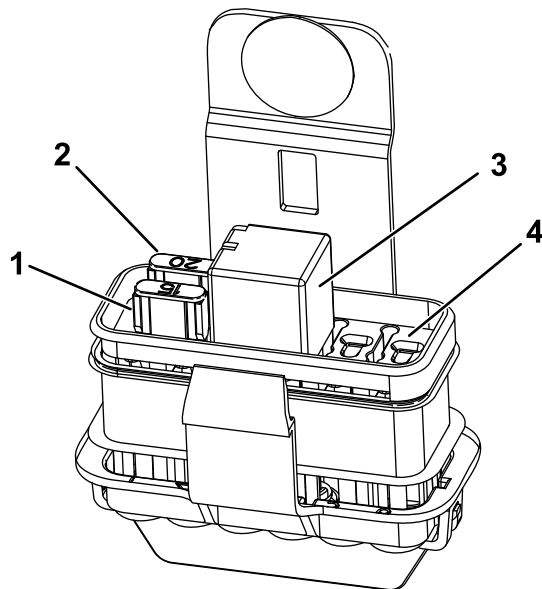

Figure 67

- | | |
|--------------------|----------------|
| 1. Auxiliary, 15 A | 3. Start relay |
| 2. Main, 20 A | 4. Open |

Jump-Starting the Machine

1. Check and clean corrosion from the battery terminals before jump-starting. Ensure that the connections are tight.

⚠ CAUTION

Corrosion or loose connections can cause unwanted electrical voltage spikes at any time during the jump-starting procedure.

Do not attempt to jump-start the machine with loose or corroded battery terminals, or damage to the engine or EFI may occur.

⚠ DANGER

Jump-starting a weak battery that is cracked or frozen or has a low electrolyte level or an open/shorted battery cell can cause an explosion, resulting in serious personal injury.

Do not jump-start a weak battery if these conditions exist.

2. Make sure that the booster battery is a good and fully charged lead-acid battery at 12.6 V or greater.

Note: Use properly sized jumper cables with short lengths to reduce voltage drop between systems. Make sure that the cables are color coded or labeled for the correct polarity.

⚠ CAUTION

Connecting the jumper cables incorrectly (wrong polarity) can immediately damage the EFI system.

Be certain of battery-terminal polarity and jumper-cable polarity when hooking up the batteries.

⚠ WARNING

Batteries contain acid and produce explosive gases.

- Shield your eyes and face from the batteries at all times.
- Do not lean over the batteries.

Note: Ensure that the vent caps are tight and level. Place a damp cloth, if available, over any vent caps on both batteries. Also ensure that the

machines do not touch and that both electrical systems are off and at the same rated system voltage. These instructions are for negative ground systems only.

3. Connect the positive (+) cable to the positive (+) terminal of the discharged battery that is wired to the starter or solenoid as shown in [Figure 68](#).

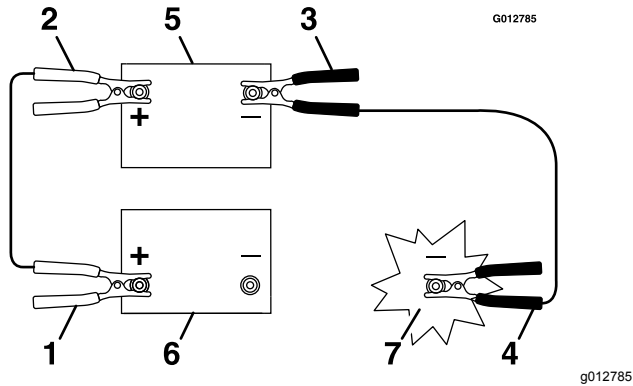
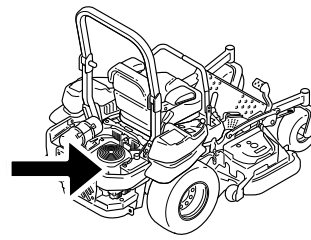

Figure 68

- | | |
|--|-----------------------|
| 1. Positive (+) cable on discharged battery | 5. Booster battery |
| 2. Positive (+) cable on booster battery | 6. Discharged battery |
| 3. Negative (-) cable on the booster battery | 7. Engine block |
| 4. Negative (-) cable on the engine block | |



g024213
g024213

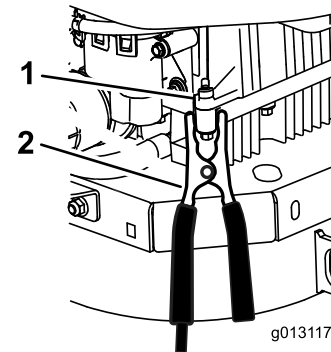

Figure 69

- | | |
|-----------------|-----------------------|
| 1. Engine block | 2. Negative (-) cable |
|-----------------|-----------------------|

7. Start the machine and remove the cables in the reverse order of connection (disconnect the negative cable from the engine block first).

4. Connect the other end of the positive cable to the positive terminal of the booster battery.
5. Connect the black negative (-) cable to the other terminal (negative) of the booster battery.
6. Make the final connection on the engine block of the stalled machine (not to the negative battery post), away from the battery, and stand back ([Figure 69](#)).

Drive System Maintenance

Checking the Seat Belt

Service Interval: Before each use or daily

Inspect the seat belt for wear, cuts, and proper operation of the retractor and buckle. Replace the seat belt if it is damaged.

Checking the Roll-Bar Knobs

Service Interval: Before each use or daily

⚠ WARNING

To avoid injury or death from rollover, keep the roll bar in the fully raised, locked position and use the seat belt.

Ensure that the seat is secured to the machine.

- Check that both the mounting hardware and the knobs are in good working condition.
- Make sure that the knobs are fully engaged with the roll bar in the raised position.

Note: The upper hoop of the roll bar may need to be pushed forward or pulled rearward to fully engage both knobs ([Figure 70](#) and [Figure 71](#)).

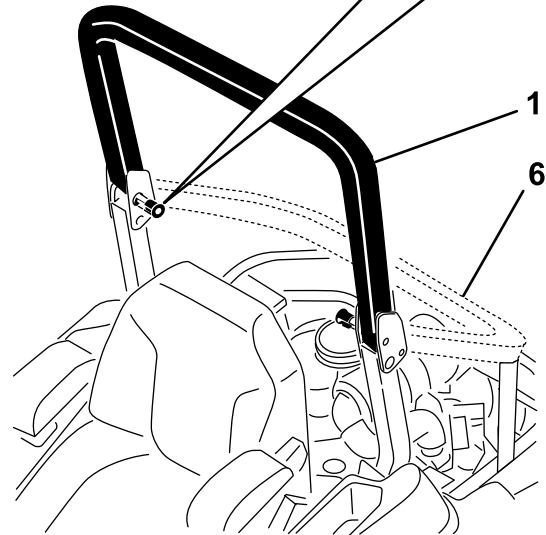
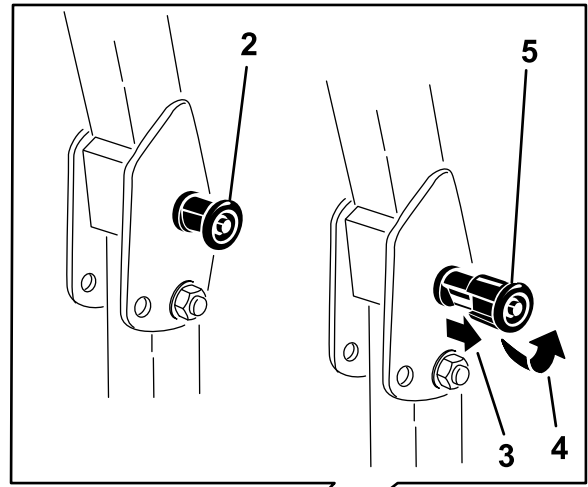

g228804

Figure 70

- | | |
|---|--|
| 1. Roll bar in the upright position | 4. Rotate the roll-bar knob 90 degrees. |
| 2. Roll-bar knob in the latched position | 5. Roll-bar knob in the unlatched position |
| 3. Pull the roll-bar knob out and rotate it 90 degrees. | 6. Roll bar in the folded position |

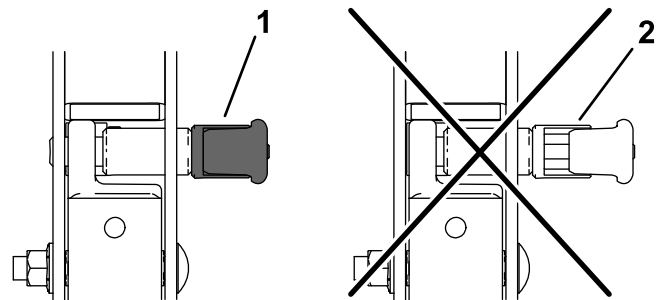

g228981

Figure 71

- | | |
|------------|---|
| 1. Engaged | 2. Partially engaged—do not operate with the roll bar in this position. |
|------------|---|

Adjusting the Tracking

1. Disengage the blade-control switch (PTO).
2. Drive to an open flat area, move the motion-control levers to the NEUTRAL-LOCK position.
3. Move the throttle midway between the FAST and SLOW positions.
4. Move both motion-control levers all the way forward until they both hit the stops in the T-slot.
5. Check which way the machine tracks.
6. Engage the parking brake, shut off the engine, and remove the key.
7. Adjust the stop plates as needed.
 - If the machine tracks to the right, loosen the bolts and adjust the left stop plate rearward on the left T-slot until the machine tracks straight (Figure 72).
 - If the machine tracks to the left, loosen the bolts and adjust the right stop plate rearward on the right T-slot until the machine tracks straight (Figure 72).
8. Tighten the stop plate (Figure 72).

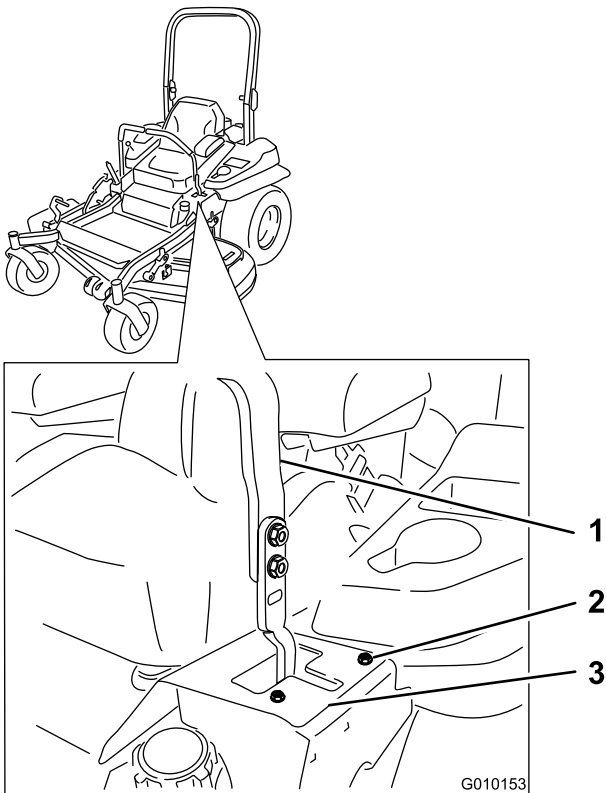

Figure 72

Left control lever shown

- | | |
|------------------|---------------|
| 1. Control lever | 3. Stop plate |
| 2. Bolt | |

Checking the Tire Pressure

Service Interval: Every 50 hours/Monthly (whichever comes first)

Maintain the air pressure in the rear tires at 90 kPa (13 psi). Uneven tire pressure can cause uneven cut. Check the tires when they are cold to get the most accurate pressure reading.

Note: The front tires are semi-pneumatic tires and do not require air pressure maintenance.

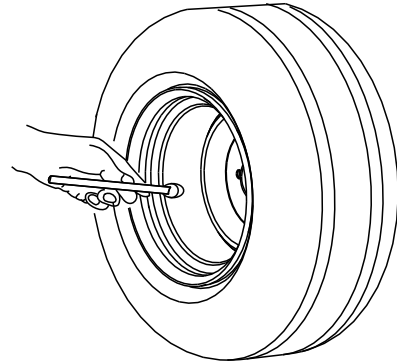

Figure 73

g001055

Checking the Wheel Lug Nuts

Check and torque the wheel lug nuts to 122 to 129 N·m (90 to 95 ft-lb).

Checking the Wheel-Hub Slotted Nut

Service Interval: After the first 100 hours

Every 500 hours

Check and ensure that the torque of the slotted nut is 286 to 352 N·m (211 to 260 ft-lb).

Note: Do not use anti-seize compound on wheel hub.

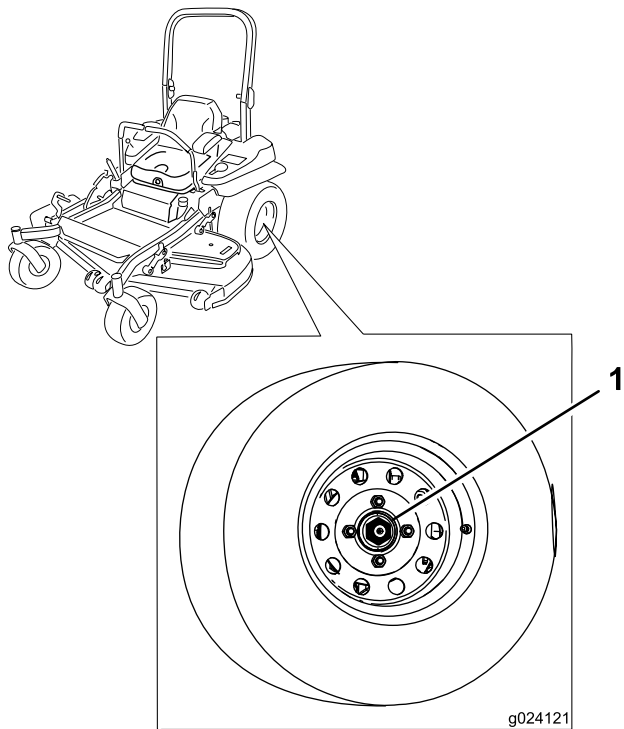

Figure 74

1. Slotted nut

Adjusting the Caster-Pivot Bearing

Service Interval: Every 500 hours/Yearly (whichever comes first)

1. Park the machine on a level surface, disengage the blade-control switch (PTO), and engage the parking brake.
2. Shut off the engine, remove the key, and wait for all moving parts to stop before leaving the operating position.
3. Remove the dust cap from caster and tighten the locknut (**Figure 75**).
4. Tighten the locknut until the spring washers are flat, and then back off a 1/4 turn to properly set the preload on the bearings (**Figure 75**).

Important: Make sure that the spring washers are installed correctly as shown in **Figure 75**.

5. Install the dust cap (**Figure 75**).

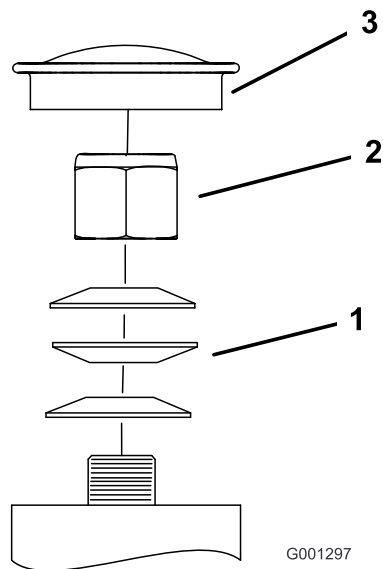

Figure 75

1. Spring washers
2. Locknut
3. Dust cap

Removing the Clutch Shim

Some later model year units have been built with clutches that contain a brake shim. When the clutch brake has worn to the point where the clutch no longer engages consistently, you can remove the shim to extend the clutch life.

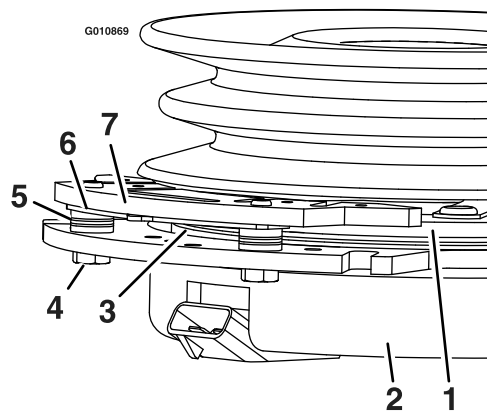

Figure 76

1. Armature
2. Field shell
3. Rotor
4. Brake-mounting bolt
5. Brake spacer
6. Re-gap shim
7. Brake pole

1. Park the machine on a level surface, disengage the blade-control switch (PTO), and engage the parking brake.
2. Shut off the engine, remove the key, and wait for all moving parts to stop before leaving the operating position.
3. Using an air compressor, blow out any debris from under the brake pole and around the brake spacers (Figure 77).

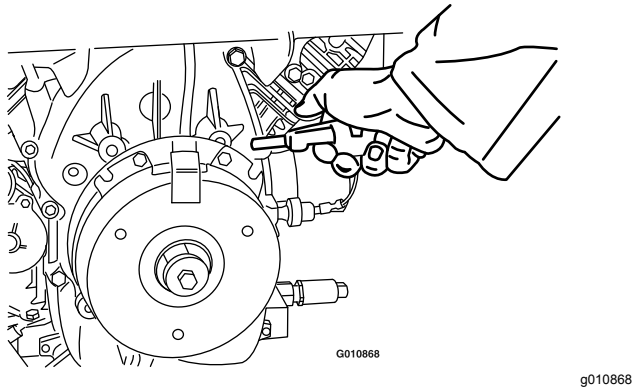

Figure 77

4. Check the condition of the wire-harness leads, connectors, and terminals.

Note: Clean or repair as necessary.
5. Verify that 12 V is present at the clutch connector when the blade-control switch (PTO) switch is engaged.
6. Measure the gap between the rotor and armature. If the gap is greater than 1 mm (0.04 inch), do the following steps:

- A. Loosen both brake-mounting bolts 1/2 to 1 full turn as shown in Figure 78.

Note: Do not remove the brake pole from the field shell/armature. The brake pole has worn to match the armature and needs to continue to match after you remove the shim to ensure proper brake torque.

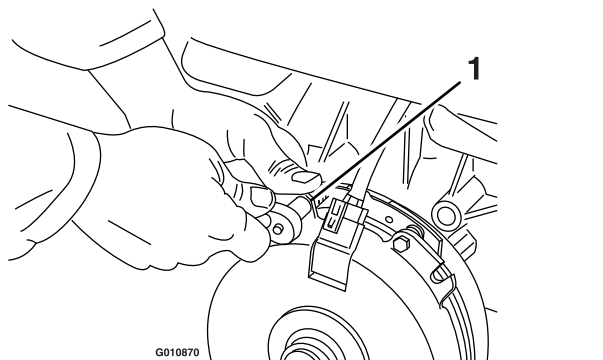

Figure 78

1. Brake-mounting bolt

- B. Using needle-nose pliers, or by hand, hold the tab and remove the shim (Figure 79).

Note: Do not discard the shim until the clutch is functioning properly.

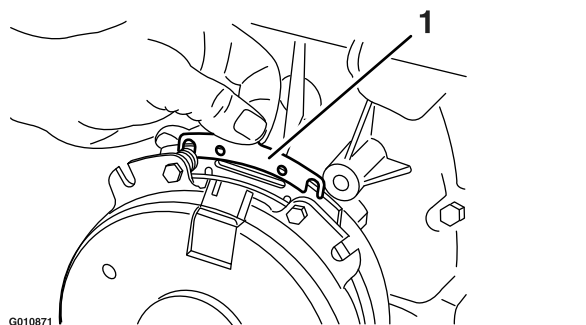

Figure 79

1. Shim

- C. Using a pneumatic line, blow out any debris from under the brake pole and around the brake spacers.
- D. Torque each bolt (M6 x 1) to 12.3 to 13.7 N·m (9.5 to 10.5 ft-lb).
- E. Using a 0.25 mm (0.01 inch) thick feeler gauge, verify that a gap is present between the rotor and the armature face on both sides of the brake pole as shown in Figure 80 and Figure 81.

Note: Due to the way the rotor and the armature faces wear (peaks and valleys) it is sometimes difficult to measure the gap accurately.

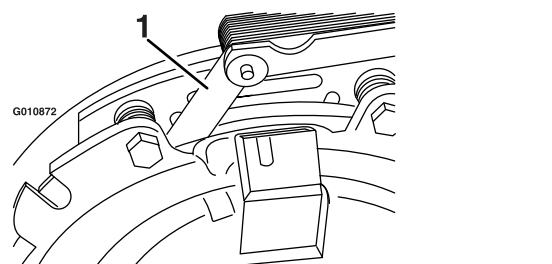

Figure 80

1. Feeler gauge

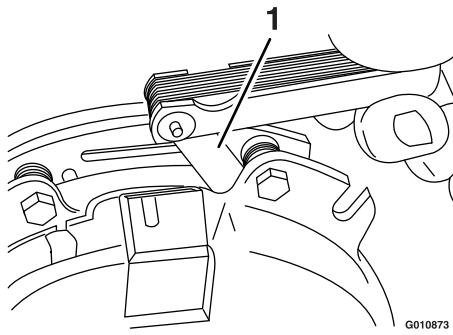

Figure 81

1. Feeler gauge

- If the gap is less than 0.25 mm (0.01 inch), then install the shim.
- If the gap is sufficient, proceed to the safety check in step **F**.

F. Perform the following safety check:

- i. Sit on the seat and start the engine.
- ii. Make sure that the blades do not engage with the blade-control switch (PTO) in the OFF position, and that the clutch is disengaged.

If the clutch does not disengage, install the shim again.

- iii. Engage and disengage the blade-control switch (PTO) 10 consecutive times to ensure that the clutch is functioning properly.

Cooling System Maintenance

Cleaning the Engine Screen and Engine-Oil Cooler

Service Interval: Before each use or daily

Remove any buildup of grass, dirt, or other debris from the oil cooler and the engine screen ([Figure 82](#)).

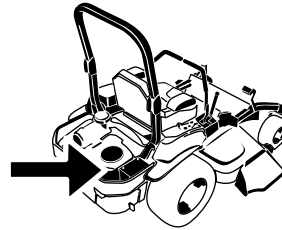

G008804
g008804

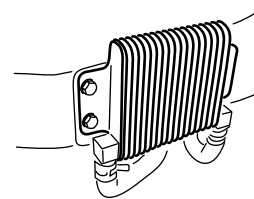

G009191
g009191

Figure 82

Remove any buildup of grass, dirt, or other debris from the engine screen. This helps ensure adequate cooling and correct engine speed and reduces the possibility of overheating and mechanical damage to the engine ([Figure 79](#)).

Cleaning the Engine-Cooling Fins and Shrouds

Service Interval: Every 100 hours/Yearly (whichever comes first)

1. Park the machine on a level surface, disengage the blade-control switch (PTO), and engage the parking brake.
2. Shut off the engine, remove the key, and wait for all moving parts to stop before leaving the operating position.
3. Remove the air-intake screen, the recoil starter, and the fan housing (Figure 83).
4. Clean the debris and grass from the engine parts.
5. Install the air-intake screen, the recoil starter, and the fan housing (Figure 83).

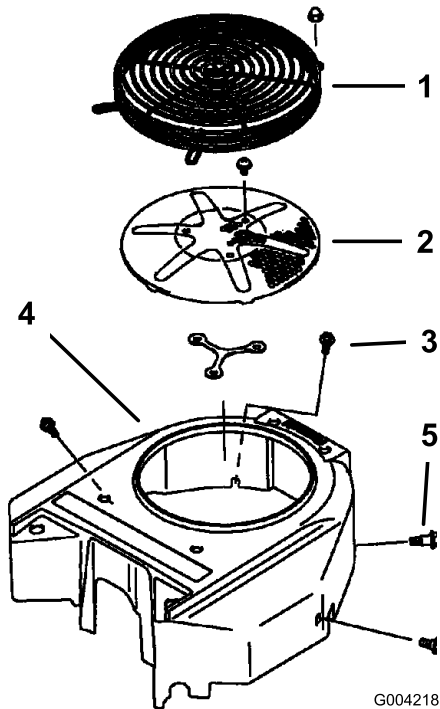

Figure 83

- | | |
|-----------------------------|----------------|
| 1. Engine guard | 4. Fan housing |
| 2. Engine air-intake screen | 5. Screw |
| 3. Bolt | |

Checking and Cleaning the Hydraulic-Unit Shrouds

Service Interval: Before each use or daily

1. Park the machine on a level surface, disengage the blade-control switch (PTO), and engage the parking brake.
2. Shut off the engine, remove the key, and wait for all moving parts to stop before leaving the operating position.
3. Move the seat forward.
4. Clean the debris and grass from the hydraulic-unit shrouds (Figure 84).
5. Position the seat.

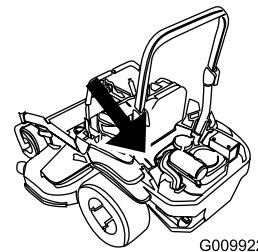

G009922

g009922

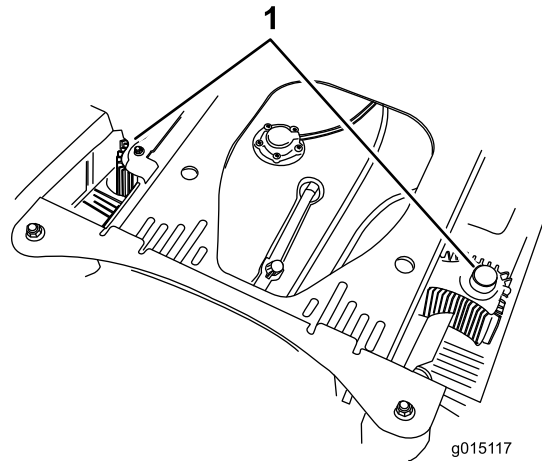

g015117

g015117

Figure 84

1. Hydraulic-unit shrouds

Brake Maintenance

Adjusting the Parking Brake

Service Interval: After the first 100 hours

Every 500 hours thereafter

Note: Perform this procedure at the recommended service interval or when a brake component has been removed or replaced.

1. Park the machine on a level surface, disengage the blade-control switch (PTO), and engage the parking brake.
2. Shut off the engine, remove the key, and wait for all moving parts to stop before leaving the operating position.
3. Raise the back of the machine and support the machine with jack stands.

CAUTION

Raising the machine for service or maintenance relying solely on mechanical or hydraulic jacks could be dangerous. The mechanical or hydraulic jacks may not be enough support or may malfunction allowing the machine to fall, which could cause injury.

Do not rely solely on mechanical or hydraulic jacks for support. Use adequate jack stands or equivalent support.

4. Remove the rear tires from the machine.
5. Remove any debris from the brake area.
6. Rotate the drive-wheel release handle to the released position; refer to [Using the Drive-Wheel-Release Valves \(page 37\)](#).
7. Check to see if there is a visible gap between the L-bracket and the linkage stop ([Figure 85](#)).

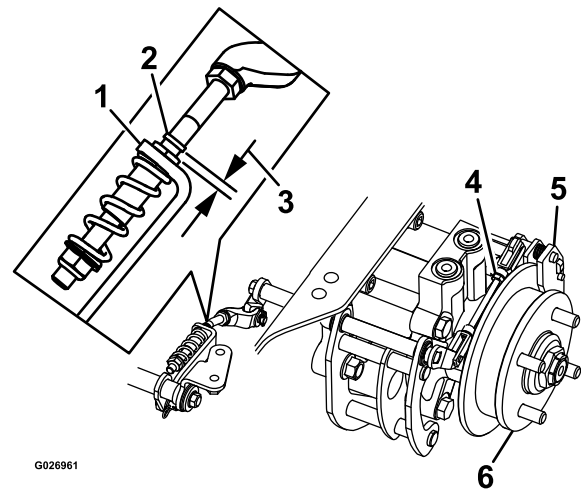

Figure 85
Left Side Shown

1. L-bracket
 2. Linkage stop
 3. Gap
 4. Rear linkage assembly
 5. Caliper
 6. Wheel hub
-
8. Disengage the parking brake, the lever should be in the down position.
 9. Turn the wheel hub by hand in both directions relative to the caliper; the wheel hub should move freely between the caliper.
 10. If a gap is needed or the wheel hub does not move freely:
 - A. Disengage the parking brake.
 - B. Disconnect and fine-tune the rear linkage assembly:
 - Shorten the link to create a gap.
 - Lengthen the link to allow wheel hub movement.
 - C. Connect the rear linkage assembly.
 11. Engage the parking brake and check the gap.
 12. Repeat steps 8 through 12 until a visible gap is achieved and the wheel hub rotates freely.
 13. Repeat this procedure for the brake on the opposite side.
 14. Rotate the drive-wheel release handle to the operating position; refer to [Using the Drive-Wheel-Release Valves \(page 37\)](#).
 15. Install the rear tires and torque the lug nuts; refer to [Checking the Wheel Lug Nuts \(page 57\)](#).
 16. Remove the jack stands.

Belt Maintenance

Inspecting the Belts

Service Interval: Every 50 hours

Replace the belt if it is worn. The signs of a worn belt include squealing while the belt is rotating; the blades slipping while cutting grass; and frayed edges, burn marks, and cracks on the belt.

Replacing the Mower Belt for Side-Discharge Mower Decks

1. Park the machine on a level surface, disengage the blade-control switch (PTO), and engage the parking brake.
2. Shut off the engine, remove the key, and wait for all moving parts to stop before leaving the operating position.
3. Lower the mower to the 76 mm (3 inch) height of cut.
4. Remove the belt covers (Figure 86).

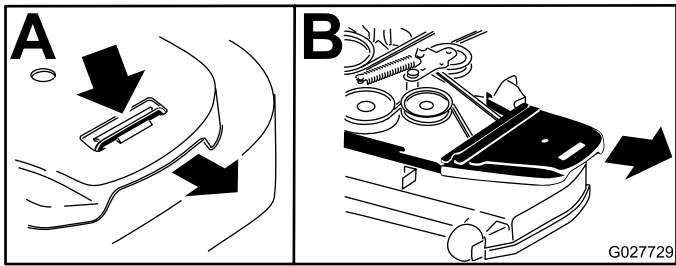

Figure 86

1. Push the tab down.
2. Remove the belt cover.

5. Use a ratchet in the square hole in the idler arm to remove tension on the idler spring (Figure 87).
6. Remove the belt from the mower-deck pulleys.
7. Remove the belt guide on the spring-loaded idler arm (Figure 87).
8. Remove the existing belt.
9. Install the new belt around the mower pulleys and the clutch pulley under the engine (Figure 87).

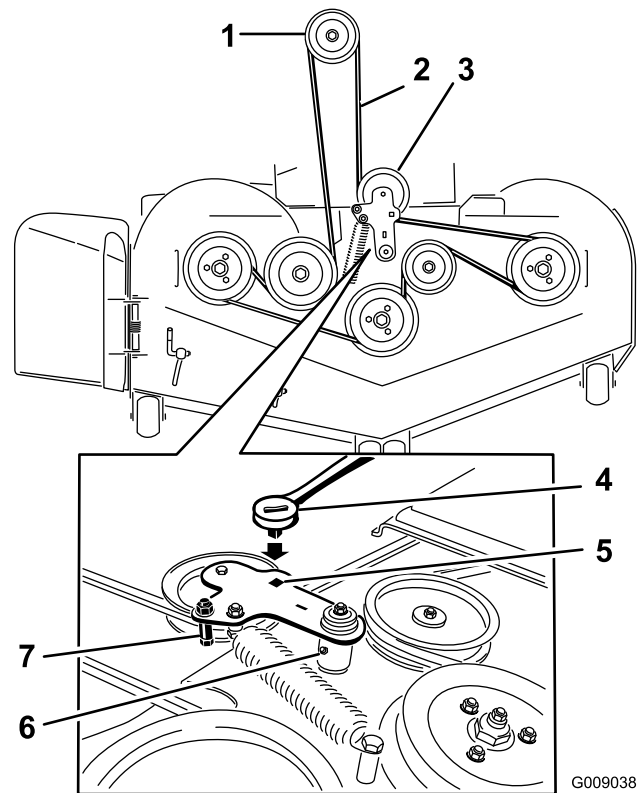

Figure 87

1. Clutch pulley
2. Mower belt
3. Spring-loaded idler pulley
4. Ratchet
5. Square hole in the idler arm for the ratchet
6. Idler-grease fitting
7. Belt guide

10. Install the belt guide on the idler arm (Figure 87).
11. Using the ratchet in the square hole, install the idler spring (Figure 87).

Note: Make sure that the spring ends are seated in the anchor grooves.

12. Install the belt covers (Figure 88).

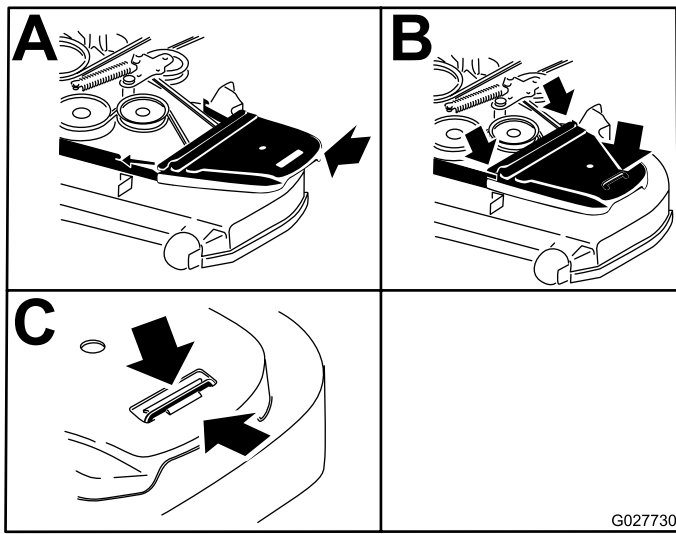

Figure 88

1. Position the belt cover.
2. Slide the belt cover under the side catches.
3. Ensure that the tab is under the metal catch.

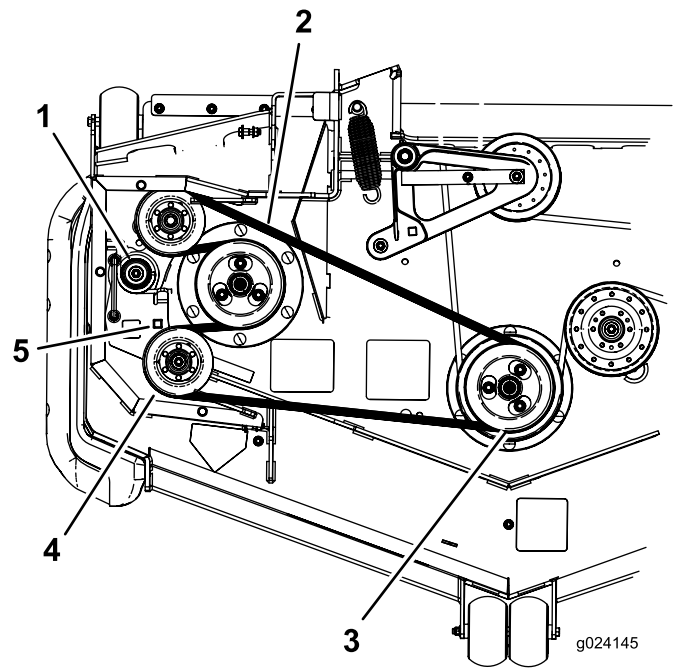

Figure 89

1. Idler spring
2. Counter-rotating belt
3. Double pulley
4. Idler pulley
5. Square hole in the idler arm for the ratchet

Replacing the Mower Belt for Rear-Discharge Mower Decks

Replacing the Counter-Rotating Belt

1. Park the machine on a level surface, disengage the blade-control switch (PTO), and engage the parking brake.
2. Shut off the engine, remove the key, and wait for all moving parts to stop before leaving the operating position.
3. Lower the mower to the 76 mm (3 inches) height of cut.
4. Lift the floor pan up to gain access to the center pulley.
5. Remove the plastic belt cover (Figure 90).
6. Remove the 3 bolts holding the metal belt cover in place and remove the metal belt cover.

7. Use a ratchet in the square hole in the idler arm to remove tension on the idler spring (Figure 89).
8. Remove the belt from the mower deck pulley (Figure 89).
9. Remove the belt from the remaining pulleys (Figure 89).
10. Route the new belt around the mower pulleys.
11. Using the ratchet in the square hole, remove the tension on the spring, and guide the new belt around the idler pulley (Figure 89).

Replacing the Mower Belt

1. Park the machine on a level surface, disengage the blade-control switch (PTO), and engage the parking brake.
2. Shut off the engine, remove the key, and wait for all moving parts to stop before leaving the operating position.
3. Lower the mower to the 76 mm (3 inches) height of cut.
4. Remove the belt covers (Figure 90).

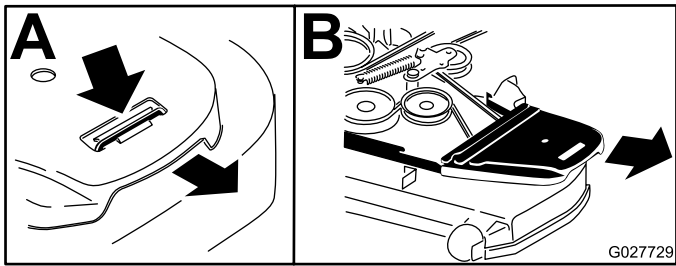

Figure 90

5. Remove the counter-rotating belt; refer to [Replacing the Counter-Rotating Belt \(page 64\)](#).
6. Use a ratchet in the square hole in the idler arm to remove tension on the idler spring ([Figure 91](#)).
7. Remove the belt from the mower-deck pulleys and the clutch pulley.
8. Install the new belt around the mower pulleys and the clutch pulley under the engine ([Figure 91](#)).

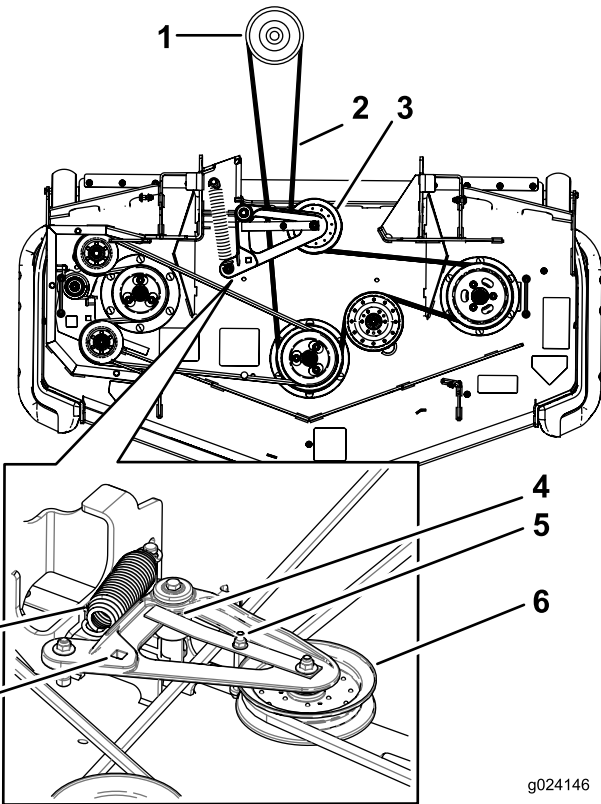

Figure 91

- | | |
|---|---|
| 1. Clutch pulley | 5. Belt guide |
| 2. Mower belt | 6. Spring-loaded idler pulley |
| 3. Spring-loaded idler pulley | 7. Square hole in the idler arm for the ratchet |
| 4. Ensure that the belt-guide tab hits against the pivot hub. | 8. Spring |

9. Rotate and ensure the belt-guide tab hits against the pivot hub ([Figure 92](#)).
10. Using the ratchet in the square hole, install the belt around the spring-loaded idler pulley ([Figure 91](#)). Seat the spring ends in the anchor grooves.
11. Install the belt covers ([Figure 92](#)).

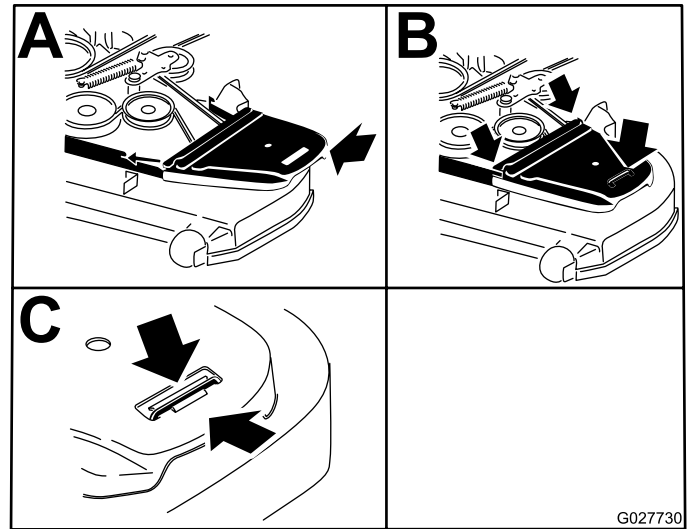

Figure 92

Replacing the Hydraulic Pump-Drive Belt

1. Park the machine on a level surface, disengage the blade-control switch (PTO), and engage the parking brake.
2. Shut off the engine, remove the key, and wait for all moving parts to stop before leaving the operating position.
3. Remove the mower belt; refer to [Replacing the Mower Belt for Side-Discharge Mower Decks \(page 63\)](#) or [Replacing the Mower Belt for Rear-Discharge Mower Decks \(page 64\)](#).
4. Raise the machine and support it with jack stands ([Figure 93](#)).

Controls System Maintenance

Adjusting the Control-Handle Position

There are 2 height positions for the control levers—high and low. Remove the bolts to adjust the height for the operator.

1. Park the machine on a level surface, disengage the blade-control switch (PTO), and engage the parking brake.
2. Shut off the engine, remove the key, and wait for all moving parts to stop before leaving the operating position.
3. Loosen the bolts and flange nuts installed in the levers ([Figure 94](#)).
4. Align the levers in the front-to-rear position by bringing the levers together to the NEUTRAL position, and slide them until they are aligned, then tighten the bolts ([Figure 95](#)).

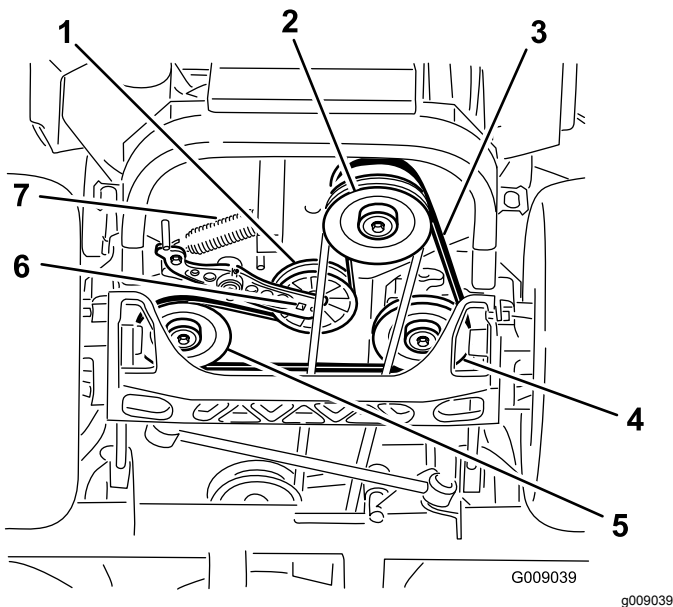

Figure 93

- | | |
|--------------------------------|---------------------------------|
| 1. Idler pulley | 5. Left hydraulic-pump pulley |
| 2. Clutch pulley | 6. Square hole in the idler arm |
| 3. Pump-drive belt | 7. Idler spring |
| 4. Right hydraulic-pump pulley | |

5. Use a ratchet in the square hole in the idler arm to remove the idler spring ([Figure 93](#)).
6. Unhook the idler spring from the frame ([Figure 93](#)).
7. Remove the belt from the hydraulic-unit-drive pulleys and the engine pulley.
8. Install the new belt around engine pulley and the 2 drive pulleys.
9. Using a ratchet in the square hole in the idler arm, install the idler spring to the frame ([Figure 93](#)).
10. Install the mower belt; refer to [Replacing the Mower Belt for Side-Discharge Mower Decks \(page 63\)](#) or [Replacing the Mower Belt for Rear-Discharge Mower Decks \(page 64\)](#).

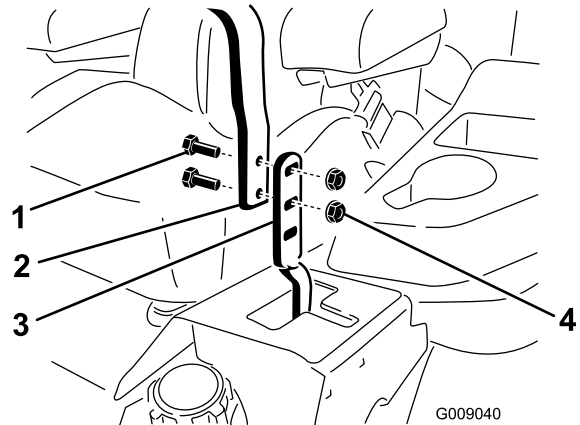

Figure 94

- | | |
|-------------|------------------|
| 1. Bolt (2) | 3. Control lever |
| 2. Handle | 4. Nut (2) |

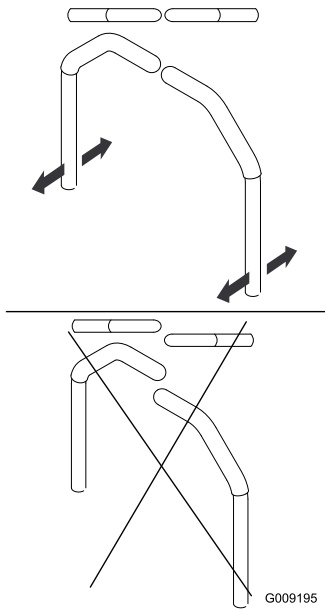

Figure 95

g009195

5. If the ends of the levers hit against each other, refer to [Adjusting the Motion-Control Neutral-Lock Pivot](#) (page 68).
6. Repeat to adjust the control levers.

Adjusting the Motion-Control Linkage

Located on either side of the machine, below the seat, are the pump-control linkages. Rotating the end nut with a 1/2-inch deep socket wrench allows fine tuning adjustments so that the machine does not move in neutral. Any adjustments should be made for neutral positioning only.

⚠ WARNING

The engine must be running and the drive wheels turning so that you can perform the adjustments. Contact with moving parts or hot surfaces may cause personal injury.

Keep your fingers, hands, and clothing clear of rotating components and hot surfaces.

1. Park the machine on a level surface, disengage the blade-control switch (PTO), move the motion-control levers to the NEUTRAL-LOCK position, and engage the parking brake.
2. Shut off the engine, remove the key, and wait for all moving parts to stop before leaving the operating position.
3. Push the deck-lift pedal, remove the height-of-cut pin, and lower the mower deck to the ground

4. Raise the rear of the machine up and support it with jack stands (or equivalent support) just high enough to allow the drive wheels to turn freely.
5. Remove the electrical connection from the seat safety switch, located under the bottom cushion of the seat.

Note: The switch is a part of the seat assembly.

6. **Temporarily** install a jumper wire across the terminals in the connector of the main wire harness.
7. Start the engine, run it at full throttle, and disengage the parking brake.

Note: Before starting the engine, ensure that the parking brake is engaged and that the motion-control levers are out. You do not have to be in the seat.

8. Run the machine at least 5 minutes with the drive levers at full forward speed to bring the hydraulic fluid up to the operating temperature.

Note: The motion-control levers must be in neutral while you are making any adjustments.

9. Bring the motion-control levers into the NEUTRAL position.
10. Adjust the pump-control-rod lengths by rotating the double nuts on the rod in the appropriate direction until the wheels slightly creep in reverse ([Figure 96](#)).

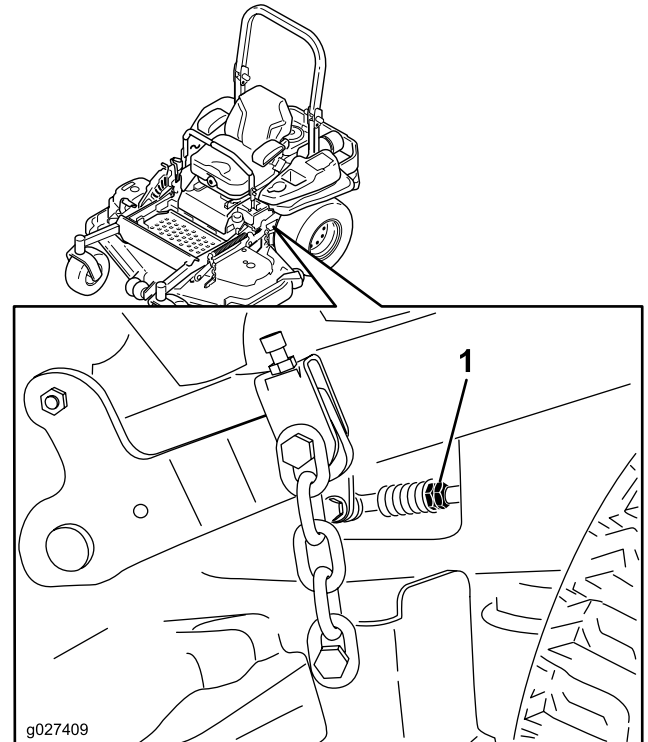

Figure 96

g027409

1. Double nuts

11. Move the motion-control levers to the REVERSE position and while applying slight pressure to the lever, allow the reverse-indicator springs to bring the levers back to neutral.

Note: The wheels should stop turning or slightly creep in reverse.

12. Shut off the machine.
13. Remove the jumper wire from the wire harness and plug the connector into the seat switch.
14. Remove the jack stands.
15. Raise the mower deck and install the height-of-cut pin.
16. Check and ensure that the machine does not creep in neutral with the parking brake disengaged.

Adjusting the Motion-Control Damper

You can adjust the top damper-mounting bolt to obtain the desired motion-control lever resistance. Refer to [Figure 97](#) for mounting options.

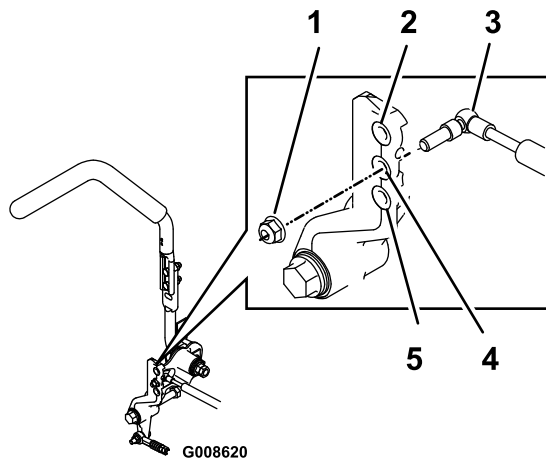

Figure 97

Right Motion Control Shown

1. Torque the locknut to 23 N·m (17 ft-lb). The bolt must protrude past the end of the locknut after torquing.
2. Most resistance (firmest feel)
3. Damper
4. Medium resistance (medium feel)
5. Least resistance (softest feel)

Adjusting the Motion-Control Neutral-Lock Pivot

You can adjust the flanged nut to obtain the desired motion-control lever resistance when moving it to the NEUTRAL-LOCK position. See [Figure 98](#) for adjustment options.

1. Loosen the jam nut.
2. Tighten or loosen the flanged nut to the desired feel.
 - For more resistance, tighten the flanged nut.
 - For less resistance, loosen the flanged nut
3. Tighten the jam nut.

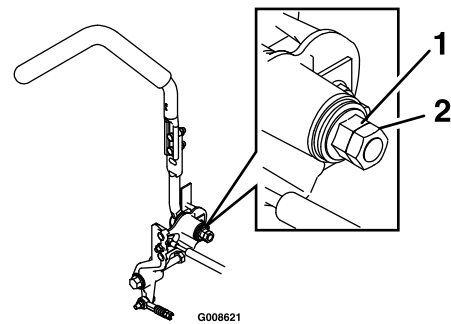

Figure 98

1. Flanged nut
2. Jam nut

Hydraulic System Maintenance

Hydraulic System Safety

- Seek immediate medical attention if fluid is injected into skin. Injected fluid must be surgically removed within a few hours by a doctor.
- Ensure that all hydraulic-fluid hoses and lines are in good condition and all hydraulic connections and fittings are tight before applying pressure to the hydraulic system.
- Keep your body and hands away from pinhole leaks or nozzles that eject high-pressure hydraulic fluid.
- Use cardboard or paper to find hydraulic leaks.
- Safely relieve all pressure in the hydraulic system before performing any work on the hydraulic system.

Hydraulic-Fluid Specifications

Hydraulic-Fluid Type: Toro® HYPR-OIL™ 500 hydraulic fluid or Mobil® 1 15W-50.

Important: Use the specified fluid. Other fluids could damage the hydraulic system.

Each Hydraulic-System Fluid Capacity: 1.5 L (52 fl oz) per side with filter change

Checking the Hydraulic Fluid

Service Interval: Every 50 hours—Check the hydraulic-fluid level.

1. Park the machine on a level surface, disengage the blade-control switch (PTO), and engage the parking brake.
2. Shut off the engine, remove the key, and wait for all moving parts to stop before leaving the operating position.
3. Allow the engine and the hydraulic system to cool for 10 minutes.

Note: The oil level on the dipstick is incorrect when the oil is checked and the machine is hot.

4. Move the seat forward.
5. Clean the area around the dipsticks of hydraulic-system reservoirs (Figure 99).

6. Remove 1 dipstick from the hydraulic reservoir (Figure 99).
 7. Wipe the dipstick off and thread the dipstick into the reservoir.
 8. Remove the dipstick and look at the end (Figure 99).
- Important:** Do not overfill the hydraulic units with fluid, as damage may occur. Do not run the machine with fluid below the add mark.
9. If the fluid level is at the add mark, slowly pour only enough fluid into the hydraulic reservoir to raise the level to the full or H line.
 10. Install the dipstick.
 11. Repeat the procedure for the opposite dipstick.

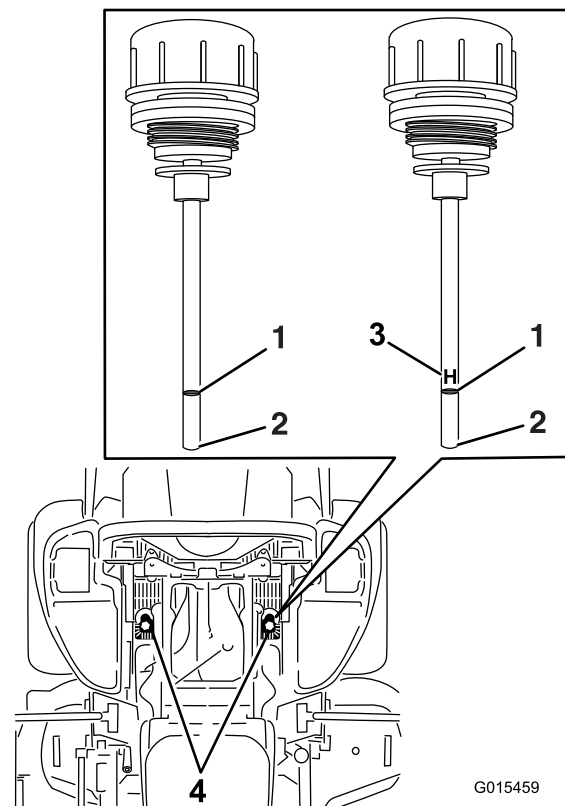

Figure 99

Either dipstick is used in the machine

- | | |
|---------|----------------------------------|
| 1. Full | 3. H —means high level |
| 2. Add | 4. Dipstick locations under seat |

Changing the Hydraulic Fluid and Filters

Service Interval: After the first 250 hours—Change the hydraulic filters and hydraulic fluid.

Every 250 hours—After the initial change—change the hydraulic-system filters and fluid when using Mobil 1 15W50 fluid. (Change it more often under dirty or dusty conditions)

Every 500 hours—After the initial change—change the hydraulic-system filters and fluid when using Toro® HYPR-OIL™ 500 fluid. (Change it more often under dirty or dusty conditions)

To replace the hydraulic fluid, the filters need to be removed. Replace both at the same time; refer to [Hydraulic-Fluid Specifications \(page 69\)](#) for fluid specifications.

1. Park the machine on a level surface, disengage the blade-control switch, and engage the parking brake.
2. Shut off the engine, remove the key, and wait for all moving parts to stop before leaving the operating position.
3. Raise the machine and support it with jack stands ([Figure 100](#)).

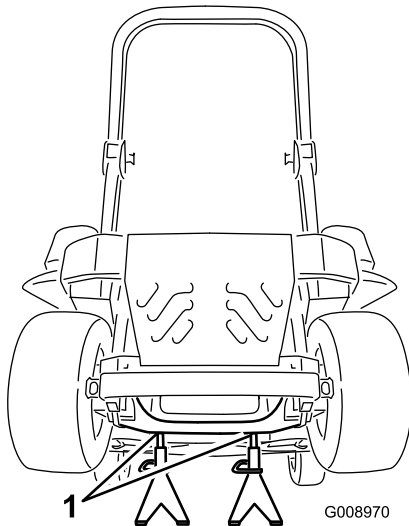

Figure 100

1. Jack stands

4. Remove both the mower belt and the pump-drive belt; refer to [Replacing the Mower Belt \(page 64\)](#) and [Replacing the Hydraulic Pump-Drive Belt \(page 65\)](#).

Note: This prevents fluid from getting on the belts.

5. Place a drain pan under the filter, remove the old filter, and wipe the surface clean ([Figure 101](#)).

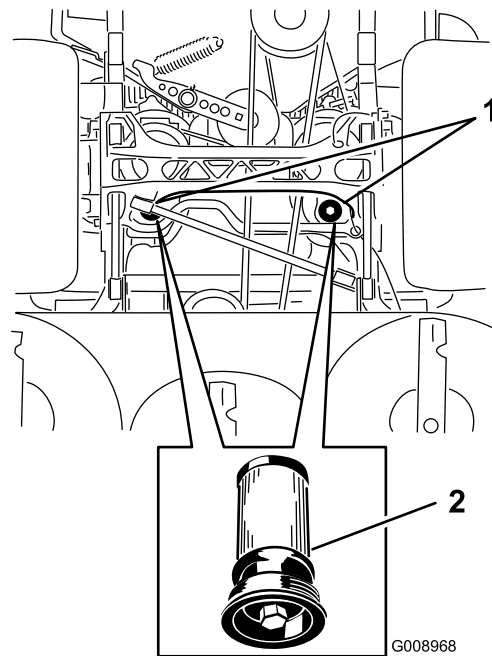

Figure 101

Bottom view of the machine

1. Filter locations
2. Hydraulic filter

6. Apply a thin coat of hydraulic fluid to the rubber gasket on the replacement filter ([Figure 101](#)).
7. Install the replacement hydraulic filter.
8. Install the pump-drive belt and the mower belt.
9. Remove the jack stands and lower the machine ([Figure 100](#)).
10. Add fluid to the hydraulic reservoir and check for any leaks.
11. Clean up any spilled fluid.
12. Start the engine and let it run for about 2 minutes to purge air from the system.
13. Shut off the engine and check for leaks.
14. Check the fluid level while the fluid is cold.
15. If required, add fluid to the hydraulic reservoir.

Note: Do not overfill.

Mower Deck Maintenance

Blade Safety

A worn or damaged blade can break, and a piece of the blade could be thrown toward you or bystanders, resulting in serious personal injury or death. Trying to repair a damaged blade may result in discontinued safety certification of the product.

- Inspect the blades periodically for wear or damage.
- Use care when checking the blades. Wrap the blades or wear gloves, and use caution when servicing the blades. Only replace or sharpen the blades; never straighten or weld them.
- On multi-bladed machines, take care as rotating 1 blade can cause other blades to rotate.

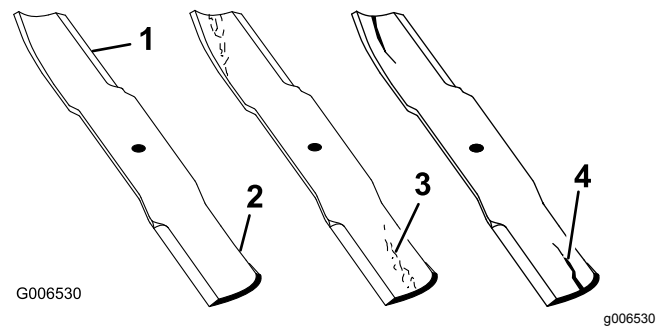

Figure 102

1. Cutting edge
2. Curved area
3. Wear/slot forming
4. Crack

Servicing the Cutting Blades

To ensure a superior quality of cut, keep the blades sharp. For convenient sharpening and replacement, you may want to keep extra blades on hand.

Before Inspecting or Servicing the Blades

1. Park the machine on a level surface, disengage the blade-control switch (PTO), and engage the parking brake.
2. Shut off the engine, remove the key, and disconnect the spark-plug wires from the spark plugs.

Inspecting the Blades

Service Interval: Before each use or daily

1. Inspect the cutting edges ([Figure 102](#)).
2. If the edges are not sharp or have nicks, remove and sharpen the blade; refer to [Sharpening the Blades \(page 73\)](#).
3. Inspect the blades, especially in the curved area.
4. If you notice any cracks, wear, or a slot forming in this area, immediately install a new blade ([Figure 102](#)).

Checking for Bent Blades

Note: The machine must be on a level surface for the following procedure.

1. Raise the mower deck to the highest height-of-cut position.
2. While wearing thickly padded gloves, or other adequate hand protection, slowly rotate the blade into a position that allows you to measure the distance between the cutting edge and the level surface the machine is on (Figure 103).

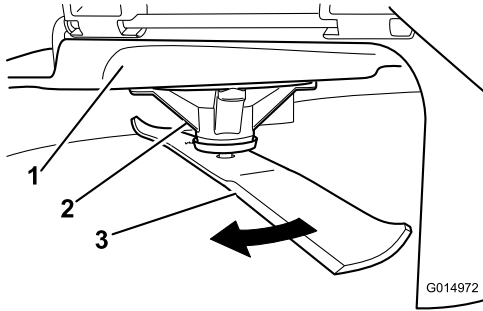

Figure 103

1. Deck
2. Spindle housing
3. Blade

3. Measure from the tip of the blade to the flat surface (Figure 104).

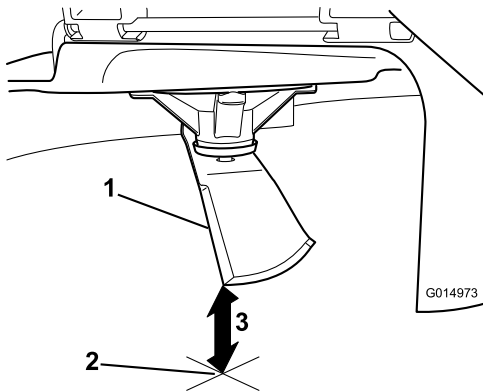

Figure 104

1. Blade (in position for measuring)
2. Level surface
3. Measured distance between blade and the surface (A)

4. Rotate the same blade 180 degrees so that the opposing cutting edge is now in the same position (Figure 105).

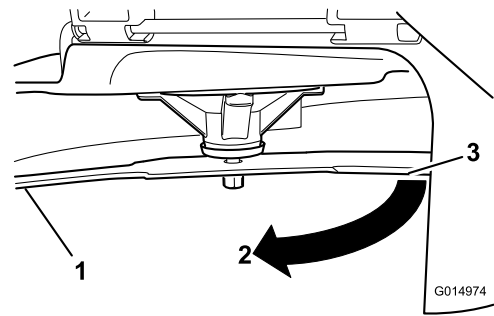

Figure 105

1. Blade (side previously measured)
2. Measurement (position used previously)
3. Opposing side of blade being moved into measurement position

5. Measure from the tip of the blade to the flat surface (Figure 106).

Note: The variance should be no more than 3 mm (1/8 inch).

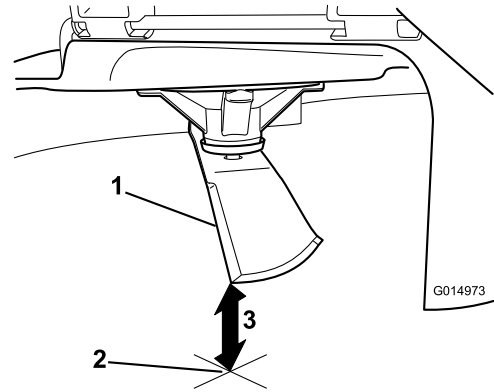

Figure 106

1. Opposite blade edge (in position for measuring)
2. Level surface
3. Second measured distance between blade and surface (B)

- A. If the difference between A and B is greater than 3 mm (1/8 inch), replace the blade with a new blade; refer to [Removing the Blades \(page 73\)](#) and [Installing the Blades \(page 73\)](#).

Note: If a bent blade is replaced with a new blade, and the dimension obtained continues to exceed 3 mm (1/8 inch), the blade spindle could be bent. Contact an Authorized Service Dealer for service.

- B. If the variance is within constraints, move to the next blade.

6. Repeat this procedure on each blade.

Removing the Blades

Replace the blades if they hit a solid object, or if the blade is out of balance or bent.

1. Place a wrench on the flat of the spindle shaft or hold the blade end using a rag or thickly padded glove.
2. Remove the blade bolt, bushing, and blade from the spindle shaft (Figure 107).

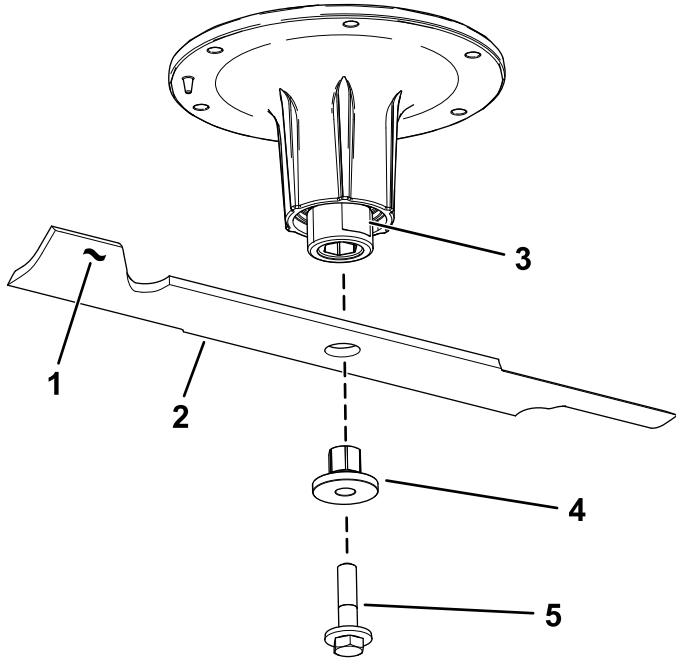

Figure 107

g295816

- | | |
|------------------------------|---------------|
| 1. Sail area of the blade | 4. Bushing |
| 2. Blade | 5. Blade bolt |
| 3. Flat of the spindle shaft | |

Note: If the blade stays in a horizontal position, the blade is balanced and can be used.

Note: If the blade is not balanced, file some metal off the end of the sail area only (Figure 108).

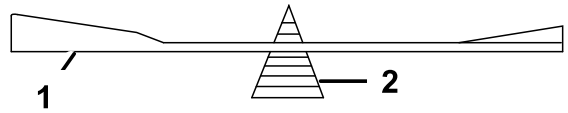

G000553

g000553

Figure 109

- | | |
|----------|-------------|
| 1. Blade | 2. Balancer |
|----------|-------------|

3. Repeat this procedure until the blade is balanced.

Installing the Blades

1. Install the bushing through the blade with the bushing flange on the bottom (grass) side of the blade (Figure 110).

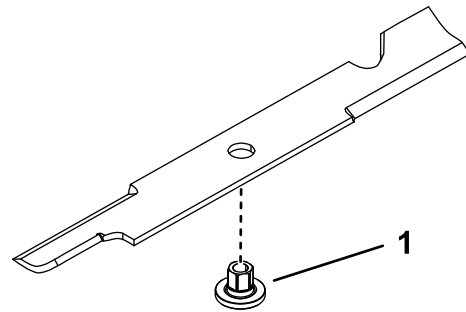

Figure 110

g255205

1. Bushing

2. Install the bushing/blade assembly into the spindle shaft (Figure 111).

Sharpening the Blades

1. Use a file to sharpen the cutting edge at both ends of the blade (Figure 108).

Note: Maintain the original angle.

Note: The blade retains its balance if the same amount of material is removed from both cutting edges.

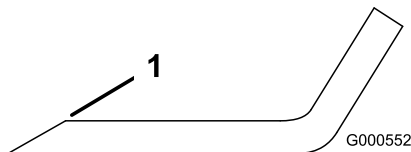

G000552

g000552

Figure 108

1. Sharpen at original angle.

2. Check the balance of the blade by putting it on a blade balancer (Figure 109).

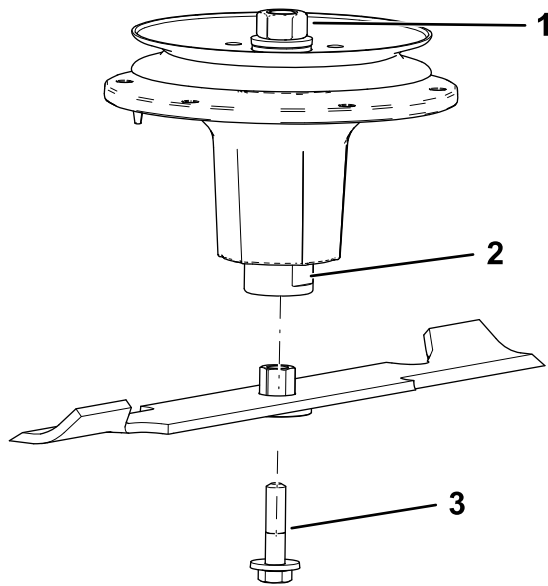

Figure 111

g298850

1. Top spindle nut
2. Flat of the spindle shaft
3. Blade bolt

3. Apply copper-based lubricant or grease to the threads of the blade bolt as needed to prevent seizing. Install the blade bolt finger-tight.
4. Place a wrench on the flat of the spindle shaft and torque the blade bolt to 75 to 81 N·m (55 to 60 ft-lb).

Leveling the Mower Deck

1. Park the machine on a level surface, disengage the blade-control switch (PTO), and engage the parking brake.
2. Shut off the engine, remove the key, and wait for all moving parts to stop before leaving the operating position.
3. Check the tire pressure in the drive tires; refer to [Checking the Tire Pressure \(page 57\)](#).
4. Position the transport lock in the latching position.
5. Push the deck-lift pedal all the way forward and the deck latches at the 14 cm (5-1/2 inch) transport position ([Figure 112](#)).

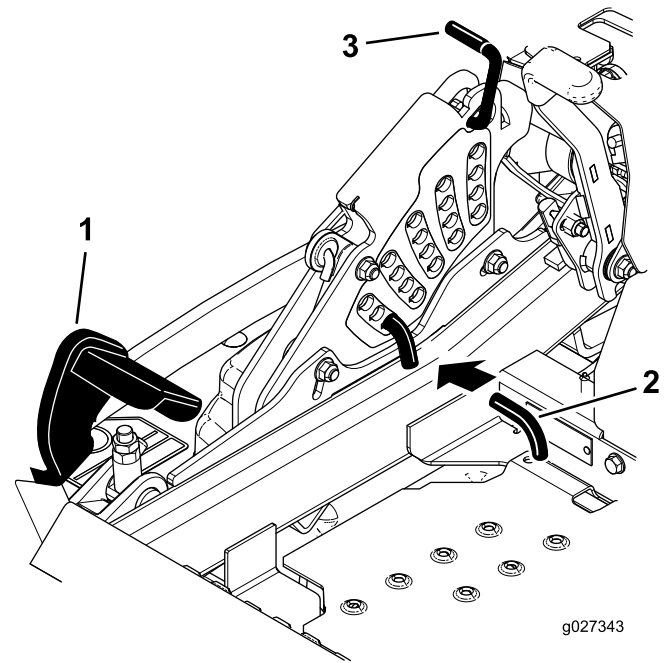

Figure 112

g027343

g027343

1. Deck-lift pedal
2. Height-of-cut pin
3. Transport lock

6. Insert the height-adjustment pin into the 7.6 cm (3 inches) cutting-height location.
7. Release the transport lock and allow the deck to lower to the cutting height.
8. For side-discharge machines, raise the discharge chute.
9. On both sides of the deck, measure from the level surface to the front tip of the blade (Position A) as shown in [Figure 113](#).

Note: The measurement should read 7.6 mm (3 inches)

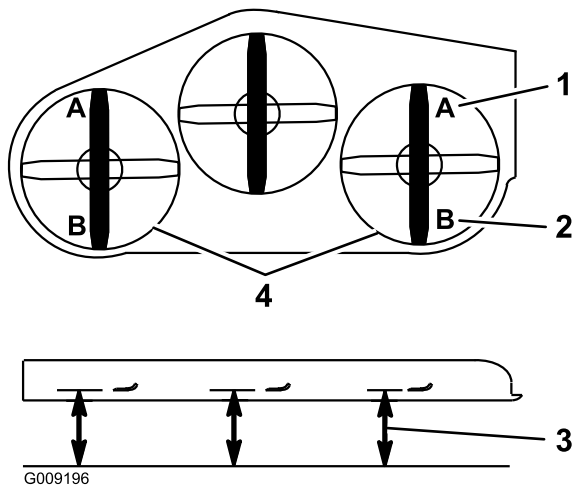

Figure 113

- | | |
|---|--|
| 1. 7.6 cm (3 inch) at position A is correct | 3. Measure here from the blade tip to the hard surface |
| 2. 8.3 cm (3-1/4 inch) at position B is correct | 4. Measure at position A and B on both sides |

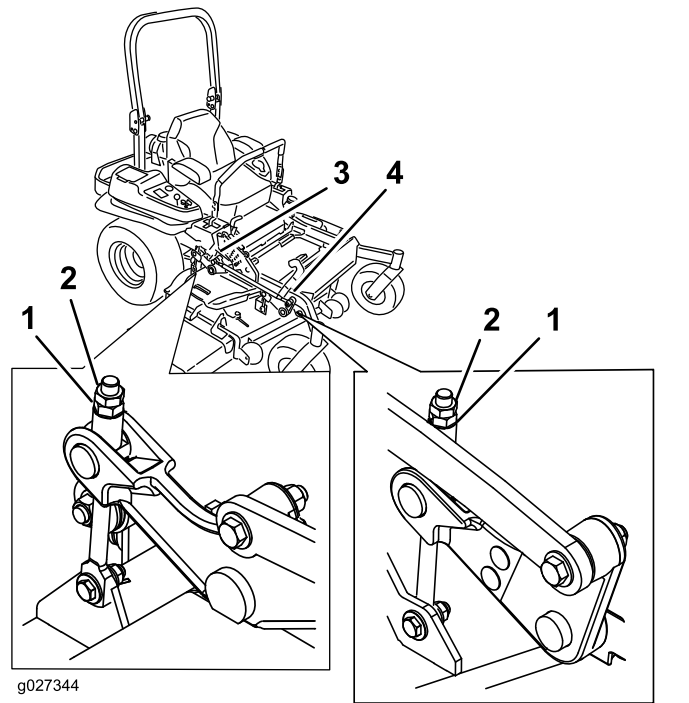

Figure 115

6000 Series Machines

- | | |
|-------------------|--------------------------|
| 1. Adjustment nut | 3. Rear deck adjustment |
| 2. Jam nut | 4. Front deck adjustment |

10. Fine-tune the adjustment nut on the front deck-lift assembly by turning it (Figure 114 or Figure 115).

Note: To increase the height, turn the adjustment nut clockwise; to decrease the height, turn the nut counterclockwise.

Note: If the front deck links do not have enough adjustment to achieve accurate cut height, you can use the single-point adjustment to gain more adjustment.

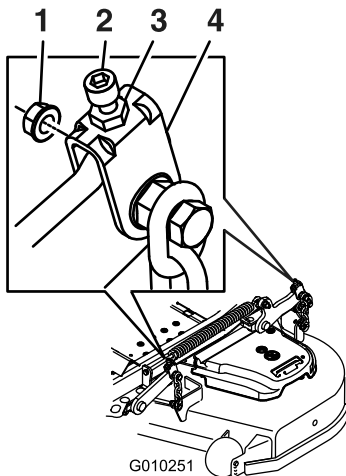

Figure 114

5000 Series Machines

- | | |
|-------------------|--------------------------|
| 1. Adjustment nut | 3. Rear deck adjustment |
| 2. Jam nut | 4. Front deck adjustment |

11. To adjust the single-point system, loosen the 2 bolts at the bottom of the height-of-cut plate (Figure 116).

Note: For rear-discharge machines, the mower deck is attached in the back holes at the factory. Refer to Figure 117. If needed, use the front holes for further adjustment when leveling the mower deck.

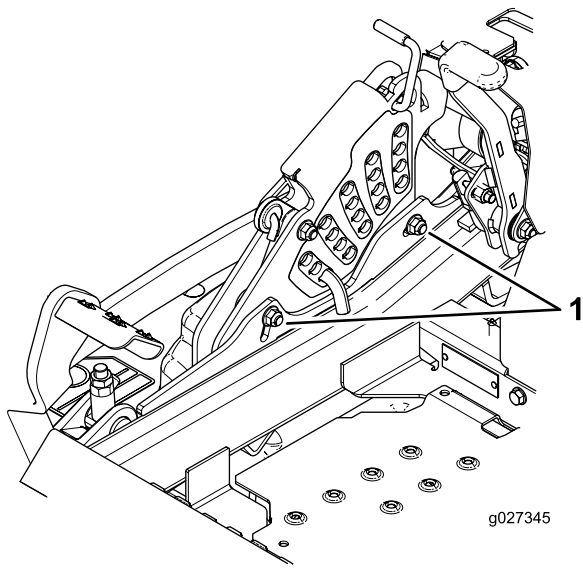

Figure 116

1. Bolts at the bottom of the height-of-cut plate

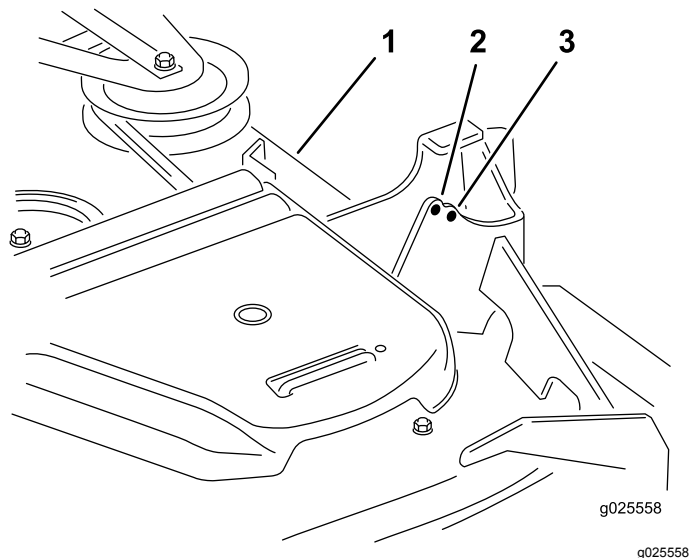

Figure 117

Rear-Discharge Machines Only

1. Mower deck
2. Front hole
3. Back hole

12. If the deck is too low, tighten the single-point-adjustment bolt by rotating it clockwise. If the deck is too high, loosen the single-point-adjustment bolt by rotating it counterclockwise (Figure 118).

Note: Loosen or tighten the single-point adjustment bolt enough to move the height-of-cut plate mounting bolts at least 1/3 the length of the available travel in their slots. This regains some up and down adjustment on each of the 4 deck links.

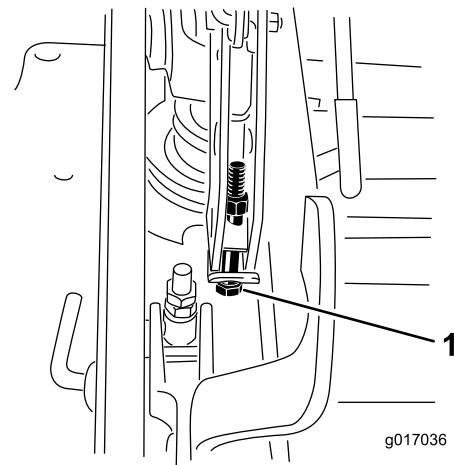

Figure 118

1. Single-point adjustment bolt

13. Tighten the 2 bolts at the bottom of the height-of-cut plate (Figure 116).

Note: In most conditions, the back blade tip should be adjusted 6.4 mm (1/4 inch) higher than the front.

14. Torque the 2 bolts to 37 to 45 N·m (27 to 33 ft-lb).
15. On both sides of the deck, measure from the level surface to the back tip of the blade (position B) as shown in Figure 113.

Note: The measurement should read 8.3 cm (3-1/4 inches)

16. Fine tune the screw adjuster by turning it to get 8.3 mm (3-1/4 inches) height (Figure 115).

To increase the height, turn the adjustment nut clockwise; to decrease, turn counterclockwise.

17. Measure until all 4 sides are the correct height.
18. Tighten all of the nuts on the deck-lift-arm assemblies.
19. For side-discharge machines, lower the discharge chute.

Removing the Mower Deck

Lock out the spring-loaded deck arms before servicing or removing the mower deck.

⚠ WARNING

Deck-lift arm assemblies have stored energy. Removing the deck with out releasing the stored energy can cause serious injury or death.

Do not attempt to disassemble the deck from the front frame without locking out the stored energy.

1. Park the machine on a level surface, disengage the blade-control switch (PTO), and engage the parking brake.
2. Shut off the engine, remove the key, and wait for all moving parts to stop before leaving the operating position.
3. Place the height adjustment pin in the 7.6 cm (3 inch) cutting-height location.

Note: This locks the deck-lift arms in the lowest position when the deck is removed and the stored energy in the deck spring is released.

4. Remove the belt covers.
5. Lift up the floor pan and insert a ratchet into the square hole in the deck idler (Figure 119 or Figure 120).
6. Rotate the deck idler clockwise, lift up on the belt-guide tab (rear-discharge machines only), and remove the mower belt (Figure 119 or Figure 120).

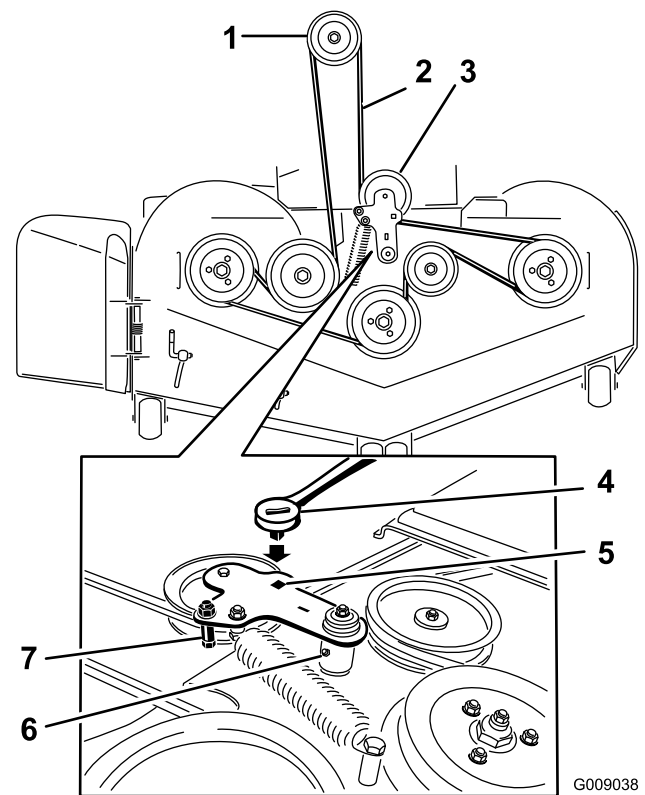

G009038
g009038

Figure 119
Side-Discharge Machines

- | | |
|-------------------------------|---|
| 1. Clutch pulley | 5. Square hole in the idler arm for the ratchet |
| 2. Mower belt | 6. Idler grease fitting |
| 3. Spring-loaded idler pulley | 7. Belt guide |
| 4. Ratchet | |

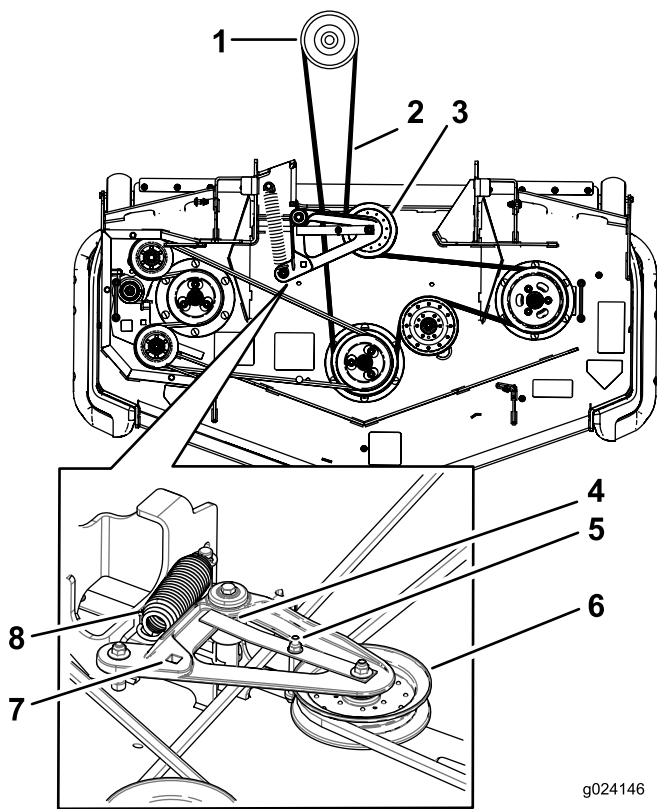

Figure 120

Rear-Discharge Machines

- | | |
|---|---|
| 1. Clutch pulley | 5. Belt guide |
| 2. Mower belt | 6. Spring-loaded idler pulley |
| 3. Spring-loaded idler pulley | 7. Square hole in the idler arm for the ratchet |
| 4. Ensure that the belt-guide tab hits against the pivot hub. | 8. Spring |

7. Remove and retain the hardware on both sides of the deck as shown in [Figure 121](#).

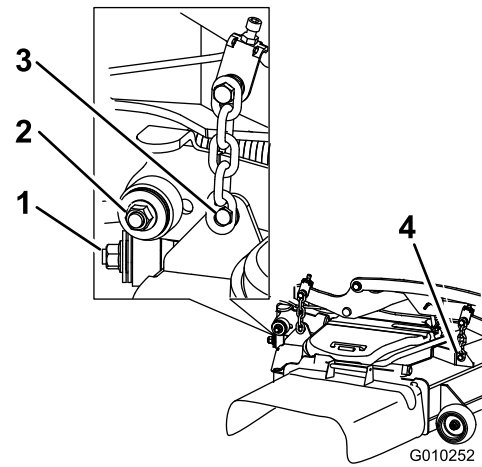

Figure 121

1. Right stabilizer
2. Deck strut (right side shown)
3. Remove the shoulder bolt and nut.
4. Remove the shoulder bolt and nut.

8. Raise the deck struts and secure them in the raised position.
9. Slide the deck out to the right side of the machine.

Replacing the Grass Deflector

Side-Discharge Machines Only

⚠ WARNING

An uncovered discharge opening could allow the machine to throw objects toward you or bystanders, resulting in serious injury. Also, contact with the blade could occur.

Never operate the machine unless you install a mulch plate, discharge deflector, or grass collection system.

1. Remove the locknut, bolt, spring, and spacer holding the deflector to the pivot brackets ([Figure 122](#)).
2. Remove the damaged or worn grass deflector ([Figure 122](#)).

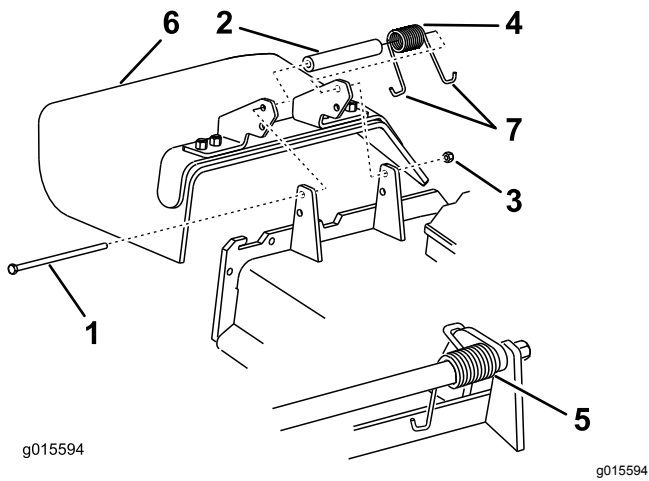

Figure 122

- | | |
|------------|-------------------------|
| 1. Bolt | 5. Spring installed |
| 2. Spacer | 6. Grass deflector |
| 3. Locknut | 7. J-hook end of spring |
| 4. Spring | |

- Place the spacer and the spring onto grass deflector.
- Place 1 J-hook end of the spring behind the deck edge.

Note: Make sure that 1 J-hook end of the spring is installed behind the deck edge before installing the bolt as shown in [Figure 122](#).

- Install the bolt and the nut.
- Place 1 J-hook end of the spring around the grass deflector ([Figure 122](#)).

Important: The grass deflector must be able to rotate. Lift the deflector up to the full open position and ensure that it rotates into the full down position.

Cleaning

Cleaning under the Mower Deck

Service Interval: Before each use or daily

- Park the machine on a level surface, disengage the blade-control switch (PTO), and engage the parking brake.
- Shut off the engine, remove the key, and wait for all moving parts to stop before leaving the operating position.
- Raise the mower deck to the TRANSPORT position.

Cleaning the Suspension System

Machines with MyRide™ Suspension System Only

Service Interval: Before each use or daily

Use compressed air to clean the suspension system.

Note: Do not clean the shock assemblies with pressurized water ([Figure 123](#)).

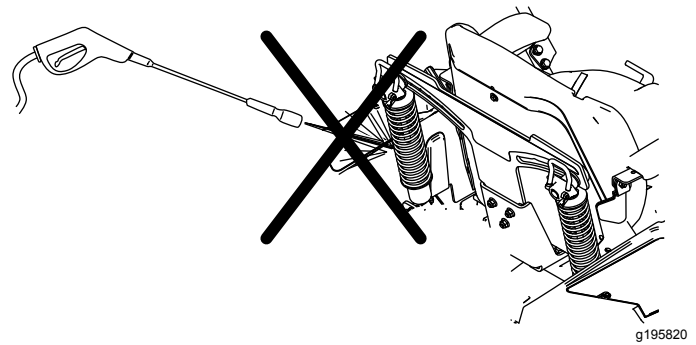

Figure 123

Disposing of Waste

Engine oil, batteries, hydraulic fluid, and engine coolant are pollutants to the environment. Dispose of these according to your state and local regulations.

Storage

Storage Safety

- Shut off the engine, remove the key, wait for all moving parts to stop, and allow the machine to cool before storing it.
- Do not store the machine or fuel near flames or drain the fuel indoors.
- Remove the key and store it in a safe place out of the reach of children.

Cleaning and Storage

1. Disengage the blade-control switch (PTO), and engage the parking brake.
2. Shut off the engine, remove the key, and wait for all moving parts to stop before leaving the operating position.
3. Remove grass clippings, dirt, and grime from the external parts of the entire machine, especially the engine and hydraulic system. Clean dirt and chaff from the outside of the engine cylinder head fins and blower housing.

Important: You can wash the machine with mild detergent and water. Do not pressure wash the machine. Avoid excessive use of water, especially near the control panel, engine, hydraulic pumps, and motors.

4. Check the parking brake operation; refer to [Engaging the Parking Brake \(page 28\)](#).
5. Service the air cleaner; refer to [Servicing the Air Cleaner \(page 46\)](#).
6. Grease the machine; refer to [Lubrication \(page 43\)](#).
7. Change the crankcase oil; refer to [Servicing the Engine Oil \(page 47\)](#).
8. Check the tire pressure; refer to [Checking the Tire Pressure \(page 57\)](#).
9. Change the hydraulic filters; refer to [Changing the Hydraulic Fluid and Filters \(page 70\)](#).
10. Charge the battery; refer to [Charging the Battery \(page 53\)](#).
11. Scrape any heavy buildup of grass and dirt from the underside of the mower, then wash the mower with a garden hose.

Note: Run the machine with the blade-control switch (PTO) engaged and the engine at high idle for 2 to 5 minutes after washing.

12. Check the condition of the blades; refer to [Servicing the Cutting Blades \(page 71\)](#).

13. Prepare the machine for storage when non-use occurs over 30 days. Prepare the machine for storage as follows:

- A. Add a petroleum-based stabilizer/conditioner to fuel in the tank. Follow mixing instructions from the stabilizer manufacturer. Do not use an alcohol-based stabilizer (ethanol or methanol).
Note: A fuel stabilizer/conditioner is most effective when mixed with fresh fuel and used at all times.
- B. Run the engine to distribute conditioned fuel through the fuel system for 5 minutes.
- C. Shut off the engine, allow it to cool, and drain the fuel tank.
- D. Start the engine and run it until it stops.
- E. Dispose of fuel properly. Recycle the fuel according to local codes.

Important: Do not store fuel containing stabilizer/conditioner longer than the duration recommended by the fuel-stabilizer manufacturer.

14. Remove and check the condition of the spark plug(s); refer to [Servicing the Spark Plug\(s\) \(page 50\)](#). With the spark plug(s) removed from the engine, pour 30 ml (2 tablespoons) of engine oil into the spark plug hole. Use the starter to crank the engine and distribute the oil inside the cylinder. Install the spark plug(s). Do not install the wire on the spark plug(s).
15. Check and tighten all bolts, nuts, and screws. Repair or replace any part that is damaged.
16. Paint all scratched or bare metal surfaces. Paint is available from your Authorized Service Dealer.
17. Store the machine in a clean, dry garage or storage area. Remove the key from the switch and keep it out of reach of children or other unauthorized users. Cover the machine to protect it and keep it clean.

Troubleshooting

Problem	Possible Cause	Corrective Action
The malfunction-indicator light (MIL) comes on.	<ol style="list-style-type: none"> 1. The engine is too hot. 2. There is old fuel in the fuel tank. 3. The fuel-shutoff valve is not open completely. 4. The air cleaner is dirty. 5. The battery is not charged. 6. Incorrect fuel filters are being used or the fuel filters are dirty. 7. The connections to the sensors electronic-control unit (ECU) and fuel injectors are not secured properly. 8. There is low voltage from the battery. 9. A fuse is blown. 	<ol style="list-style-type: none"> 1. Shut off the engine and let it cool. 2. Use new fuel. 3. Open the fuel-shutoff valve. 4. Make sure that the air cleaner and precleaner are clean. Replace if necessary. 5. Charge or replace the battery. 6. Contact an Authorized Service Dealer. 7. Contact an Authorized Service Dealer. 8. Ensure that you are using a good 12 V battery and that it is fully charged. 9. Check and replace any blown fuses.
The starter does not crank.	<ol style="list-style-type: none"> 1. The blade-control switch is engaged. 2. The parking brake is disengaged. 3. The motion-control levers are not in the NEUTRAL-LOCK position. 4. You are not sitting in the operator's seat. 5. The battery is dead. 6. The electrical connections are corroded or loose. 7. A fuse is blown. 8. A relay or switch is damaged. 	<ol style="list-style-type: none"> 1. Disengage the blade-control switch. 2. Engage the parking brake. 3. Move the motion-control levers outward to the NEUTRAL-LOCK position. 4. Sit on the operator's seat. 5. Charge the battery. 6. Check the electrical connections for good contact. 7. Replace the fuse. 8. Contact an Authorized Service Dealer.
The engine does not start, starts hard, or fails to keep running.	<ol style="list-style-type: none"> 1. The fuel tank is empty. 2. The fuel-shutoff valve is closed. 3. The oil level in the crankcase is low. 4. The throttle is not in the correct position. 5. There is dirt in the fuel filter. 6. There is dirt, water, or stale fuel is in the fuel system. 7. The air cleaner is dirty. 8. The seat switch is not functioning properly. 9. The electrical connections are corroded, loose, or damaged. 10. The relay or switch is worn or damaged. 11. The spark plug is fouled or improperly gapped. 12. The spark-plug wire is not connected. 	<ol style="list-style-type: none"> 1. Fill the fuel tank. 2. Open the fuel-shutoff valve. 3. Add oil to the crankcase. 4. Be sure that the throttle control is midway between the SLOW and FAST positions. 5. Replace the fuel filter. 6. Contact an Authorized Service Dealer. 7. Clean or replace the air-cleaner element. 8. Check the seat-switch indicator. Replace the seat if necessary. 9. Check the electrical connections for good contact. Clean the connector terminals thoroughly with electrical-contact cleaner, apply dielectric grease, and make the appropriate connections. 10. Contact an Authorized Service Dealer. 11. Adjust or replace the spark plug. 12. Check the spark-plug wire connection.

Problem	Possible Cause	Corrective Action
The engine loses power.	<ol style="list-style-type: none"> 1. The engine load is excessive. 2. The air cleaner is dirty. 3. The oil level in the crankcase is low. 4. The cooling fins and the air passages above the engine are plugged. 5. The vent hole in the fuel cap is plugged. 6. There is dirt in the fuel filter. 7. There is dirt, water, or stale fuel in the fuel system. 	<ol style="list-style-type: none"> 1. Reduce the ground speed. 2. Clean the air-cleaner element. 3. Add oil to the crankcase. 4. Remove the obstruction from the cooling fins and the air passages. 5. Clean or replace the fuel cap. 6. Replace the fuel filter. 7. Contact an Authorized Service Dealer.
The engine overheats.	<ol style="list-style-type: none"> 1. The engine load is excessive. 2. The oil level in the crankcase is low. 3. The cooling fins and air passages under the engine-blower housing are plugged. 4. The air cleaner is dirty. 5. Dirt, water, or stale fuel is in the fuel system. 	<ol style="list-style-type: none"> 1. Reduce the ground speed. 2. Add oil to the crankcase. 3. Remove the obstruction from the cooling fins and air passages. 4. Clean or replace the air-cleaner element. 5. Contact an Authorized Service Dealer
The machine pulls to the left or right (with the motion-control levers fully forward).	<ol style="list-style-type: none"> 1. The tracking needs adjustment 2. The tire pressure in the drive tires is not correct. 	<ol style="list-style-type: none"> 1. Adjust the tracking. 2. Adjust the tire pressure in the drive tires.
The machine does not drive.	<ol style="list-style-type: none"> 1. The bypass valves are not closed tight. 2. The pump belt is worn, loose, or broken. 3. The pump belt is off a pulley. 4. The idler spring is broken or missing. 5. The hydraulic fluid level is low or too hot. 	<ol style="list-style-type: none"> 1. Tighten the bypass valves. 2. Change the belt. 3. Change the belt. 4. Replace the spring. 5. Add hydraulic fluid to the reservoirs or let it cool down.
The machine vibrates abnormally.	<ol style="list-style-type: none"> 1. The cutting blade(s) is/are bent or unbalanced. 2. The blade mounting bolt is loose. 3. The engine mounting bolts are loose. 4. The engine pulley, idler pulley, or blade pulley is loose. 5. The engine pulley is damaged. 6. The blade spindle is bent. 7. The motor mount is loose or worn. 	<ol style="list-style-type: none"> 1. Install new cutting blade(s). 2. Tighten the blade mounting bolt. 3. Tighten the engine mounting bolts. 4. Tighten the appropriate pulley. 5. Contact an Authorized Service Dealer. 6. Contact an Authorized Service Dealer. 7. Contact an Authorized Service Dealer.
The cutting height is uneven.	<ol style="list-style-type: none"> 1. The blade(s) is not sharp. 2. A cutting blade(s) is/are bent. 3. The mower is not level. 4. An anti-scalp roller (if applicable) is not set correctly. 5. The underside of the mower deck is dirty. 6. The tire pressure is incorrect. 7. A blade spindle is bent. 	<ol style="list-style-type: none"> 1. Sharpen the blade(s). 2. Install a new cutting blade(s). 3. Level the mower from side-to-side and front-to-rear. 4. Adjust the anti-scalp wheel height. 5. Clean the underside of the mower deck. 6. Adjust the tire pressure. 7. Contact an Authorized Service Dealer.

Problem	Possible Cause	Corrective Action
The blades do not rotate.	<ol style="list-style-type: none"> 1. The mower deck belt is damaged, worn, loose, or broken. 2. The mower deck belt is off the pulley. 3. The pump drive belt is worn, loose, or broken. 4. The idler spring is broken or missing. 	<ol style="list-style-type: none"> 1. Install a new deck belt. 2. Install the mower belt on the deck pulley and check the idler pulley, idler arm, and spring for correct position and function. 3. Check the belt tension or install a new belt. 4. Replace the spring.
The clutch does not engage.	<ol style="list-style-type: none"> 1. The fuse is blown. 2. There is low voltage supply at the clutch. 3. The coil is damaged. 4. There is inadequate current supply. 5. The rotor/armature air gap is too large. 	<ol style="list-style-type: none"> 1. Replace the fuse. Check the coil resistance, battery charge, charging system, and wiring connections, and replace components if necessary. 2. Check the coil resistance, battery charge, charging system, and wiring connections and replace parts if necessary. 3. Replace the clutch. 4. Repair or replace the clutch lead wire or electrical system. Clean the connector contacts. 5. Remove the shim or replace the clutch.

Schematics

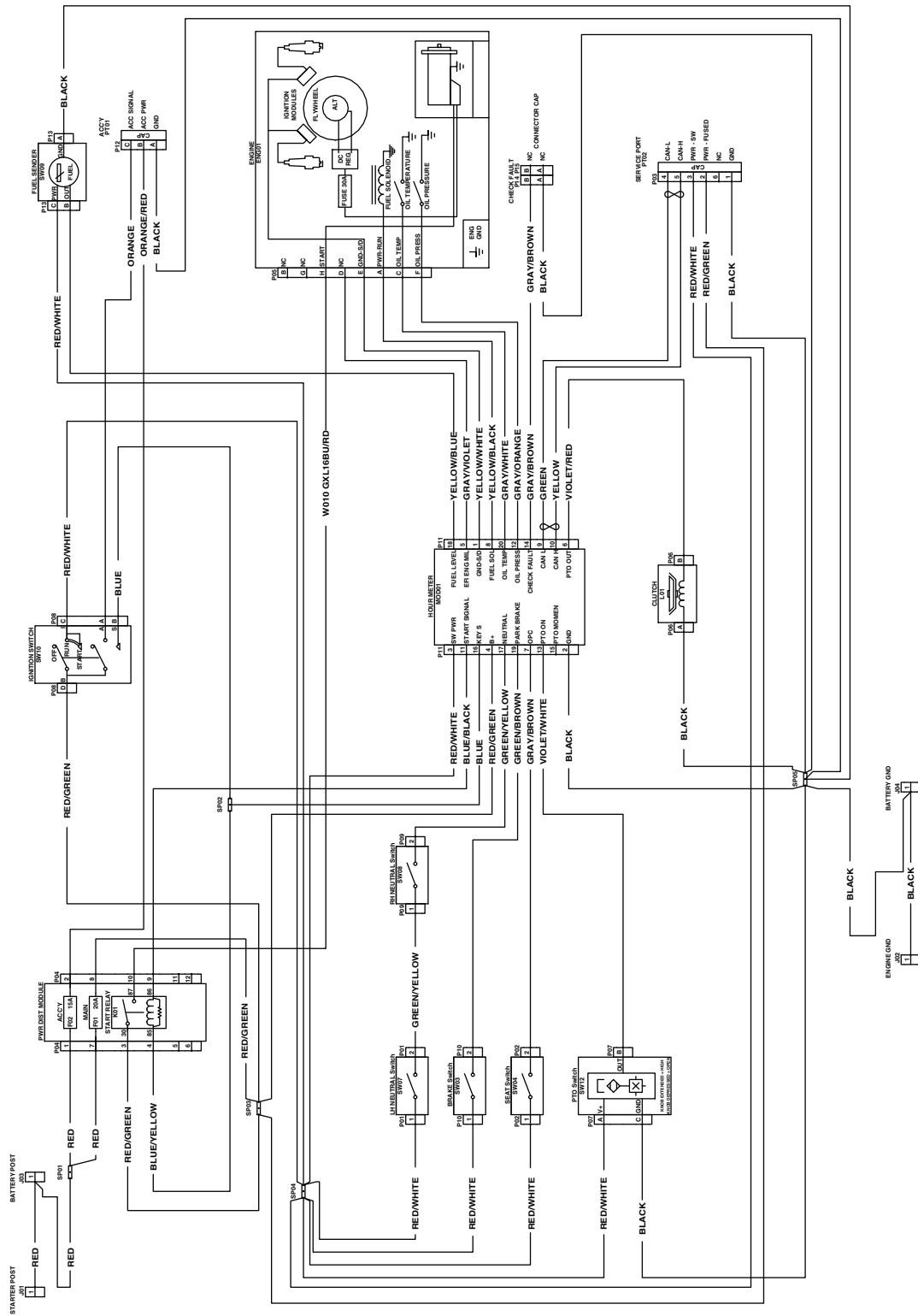

Electrical Schematic (Rev. A)

g224051

Notes:

Notes:

California Proposition 65 Warning Information

What is this warning?

You may see a product for sale that has a warning label like the following:



WARNING: Cancer and Reproductive Harm—www.p65Warnings.ca.gov.

What is Prop 65?

Prop 65 applies to any company operating in California, selling products in California, or manufacturing products that may be sold in or brought into California. It mandates that the Governor of California maintain and publish a list of chemicals known to cause cancer, birth defects, and/or other reproductive harm. The list, which is updated annually, includes hundreds of chemicals found in many everyday items. The purpose of Prop 65 is to inform the public about exposure to these chemicals.

Prop 65 does not ban the sale of products containing these chemicals but instead requires warnings on any product, product packaging, or literature with the product. Moreover, a Prop 65 warning does not mean that a product is in violation of any product safety standards or requirements. In fact, the California government has clarified that a Prop 65 warning "is not the same as a regulatory decision that a product is 'safe' or 'unsafe.'" Many of these chemicals have been used in everyday products for years without documented harm. For more information, go to <https://oag.ca.gov/prop65/faqs-view-all>.

A Prop 65 warning means that a company has either (1) evaluated the exposure and has concluded that it exceeds the "no significant risk level"; or (2) has chosen to provide a warning based on its understanding about the presence of a listed chemical without attempting to evaluate the exposure.

Does this law apply everywhere?

Prop 65 warnings are required under California law only. These warnings are seen throughout California in a wide range of settings, including but not limited to restaurants, grocery stores, hotels, schools, and hospitals, and on a wide variety of products. Additionally, some online and mail order retailers provide Prop 65 warnings on their websites or in catalogs.

How do the California warnings compare to federal limits?

Prop 65 standards are often more stringent than federal and international standards. There are various substances that require a Prop 65 warning at levels that are far lower than federal action limits. For example, the Prop 65 standard for warnings for lead is 0.5 µg/day, which is well below the federal and international standards.

Why don't all similar products carry the warning?

- Products sold in California require Prop 65 labelling while similar products sold elsewhere do not.
- A company involved in a Prop 65 lawsuit reaching a settlement may be required to use Prop 65 warnings for its products, but other companies making similar products may have no such requirement.
- The enforcement of Prop 65 is inconsistent.
- Companies may elect not to provide warnings because they conclude that they are not required to do so under Prop 65; a lack of warnings for a product does not mean that the product is free of listed chemicals at similar levels.

Why does Toro include this warning?

Toro has chosen to provide consumers with as much information as possible so that they can make informed decisions about the products they buy and use. Toro provides warnings in certain cases based on its knowledge of the presence of one or more listed chemicals without evaluating the level of exposure, as not all the listed chemicals provide exposure limit requirements. While the exposure from Toro products may be negligible or well within the "no significant risk" range, out of an abundance of caution, Toro has elected to provide the Prop 65 warnings. Moreover, if Toro does not provide these warnings, it could be sued by the State of California or by private parties seeking to enforce Prop 65 and subject to substantial penalties.



Count on it.