



**Count on it.**

**Operator's Manual**

# 24in Stand-On Aerator

Model No. 39514—Serial No. 404324200 and Up

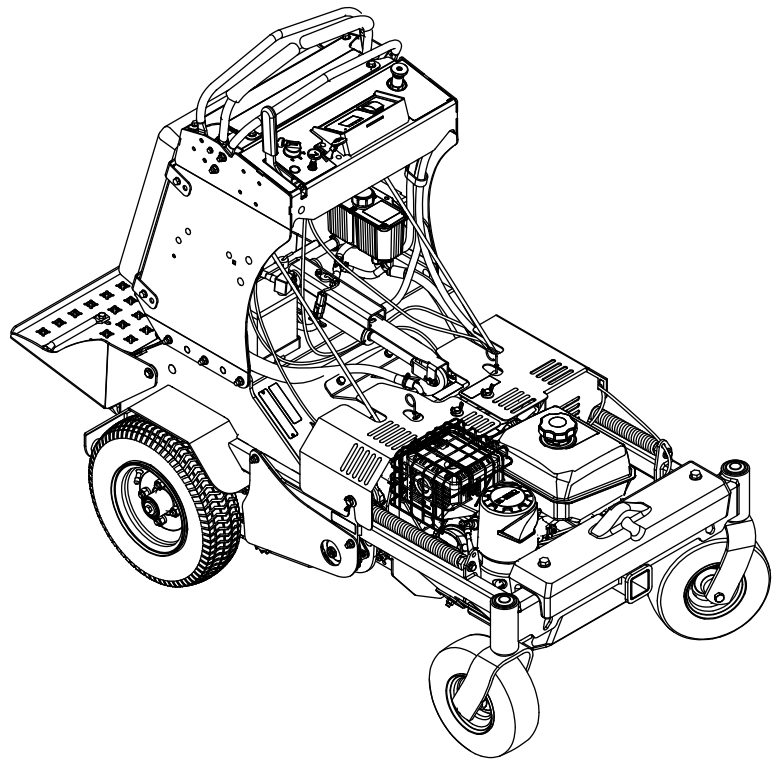

**Important:** It is a violation of California Public Resource Code Section 4442 or 4443 to use or operate the engine on any forest-covered, brush-covered, or grass-covered land unless the engine is equipped with a spark arrester, as defined in Section 4442, maintained in effective working order or the engine is constructed, equipped, and maintained for the prevention of fire.

The enclosed engine owner's manual is supplied for information regarding the US Environmental Protection Agency (EPA) and the California Emission Control Regulation of emission systems, maintenance, and warranty. Replacements may be ordered through the engine manufacturer.

**⚠ WARNING**

**CALIFORNIA  
Proposition 65 Warning**

**The engine exhaust from this product contains chemicals known to the State of California to cause cancer, birth defects, or other reproductive harm.**

**Battery posts, terminals, and related accessories contain lead and lead compounds, chemicals known to the State of California to cause cancer and reproductive harm. Wash hands after handling.**

# Introduction

This aerator is intended for use by trained operators in residential and commercial applications. The machine is primarily designed for aerating areas of well-maintained lawns on residential grounds, parks, sports fields, and on commercial grounds.

Read this information carefully to learn how to operate and maintain your product properly and to avoid injury and product damage. You are responsible for operating the product properly and safely.

Visit [www.Toro.com](http://www.Toro.com) for product safety and operation training materials, accessory information, help finding a dealer, or to register your product.

Whenever you need service, genuine Toro parts, or additional information, contact an Authorized Service Dealer or Toro Customer Service and have the model and serial numbers of your product ready. [Figure 1](#) identifies the location of the model and serial numbers

on the product. Write the numbers in the space provided.

**Important:** With your mobile device, you can scan the QR code on the serial number decal (if equipped) to access warranty, parts, and other product information.

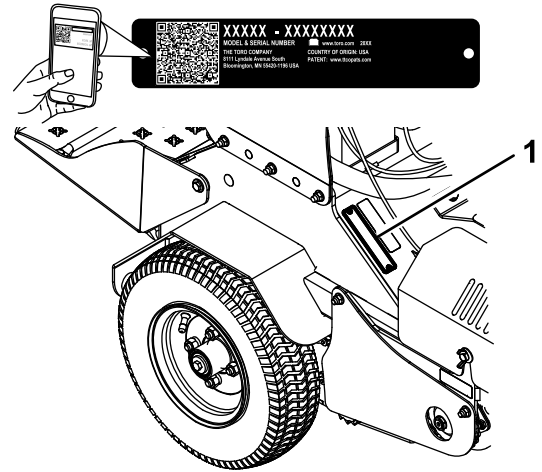

Figure 1

g246050

1. Location of the model and serial numbers

Model No. _____
Serial No. _____

This manual identifies potential hazards and has safety messages identified by the safety-alert symbol ([Figure 2](#)), which signals a hazard that may cause serious injury or death if you do not follow the recommended precautions.



Figure 2

g000502

1. Safety-alert symbol

This manual uses 2 words to highlight information. **Important** calls attention to special mechanical information and **Note** emphasizes general information worthy of special attention.

# Contents

Safety .....	4	Checking the Spark Arrester .....	36
Safety Alert Symbol .....	4	Electrical System Maintenance .....	36
General Safety .....	4	Checking the Safety Interlock .....	36
Safety and Instructional Decals .....	5	Jump Starting a Discharged Battery .....	36
Setup .....	9	Servicing the Battery .....	38
1 Checking Tire Air Pressure .....	9	Drive System Maintenance .....	39
2 Servicing the Engine Oil .....	9	Checking the Drive Tire Air Pressure .....	39
3 Checking the Battery Charge .....	9	Checking the Wheel Hub Bolts .....	39
4 Checking the Transmission Fluid .....	10	Checking the Torque of the Wheel Lug Nuts .....	39
5 Check the Auxiliary Hydraulic Fluid Level .....	10	Checking the Condition of the Chains .....	40
Product Overview .....	11	Checking the Sprocket Condition .....	40
Controls .....	11	Maintaining the Chain .....	40
Hour Meter/Tine Engagement Display .....	12	Checking the Torque of the Transmission Output Shaft Nut .....	40
Specifications .....	14	Adjusting the Motion Control Linkage .....	41
Before Operation .....	15	Adjusting the Motion Control Tracking .....	41
Before Operation Safety .....	15	Check Transmission Mount Bolt Torque .....	42
Adding Fuel .....	15	Brake Maintenance .....	42
Performing Daily Maintenance .....	16	Adjusting the Parking Brake .....	42
Adjusting the Front Reference/Speed Control Bar .....	16	Belt Maintenance .....	43
Positioning the Air-Cleaner Cover for Cold or Warm Air Temperature .....	17	Checking the Condition and Tension of the Belts .....	43
During Operation .....	17	Adjusting the Auxiliary Pump Drive Belt .....	43
During Operation Safety .....	17	Checking the Transmission Drive Belt Tension .....	43
Using the Smart Controller/Electronic Depth Control .....	19	Hydraulic System Maintenance .....	44
Opening and Closing the Fuel Shutoff Valve .....	22	Auxiliary Hydraulic Fluid Specification .....	44
Starting the Engine .....	22	Checking the Auxiliary Hydraulic Fluid Level .....	44
Lowering the Tines .....	22	Changing the Auxiliary Hydraulic Reservoir Fluid and Filter .....	44
Changing the Tine Depth Setting .....	22	Transmission Fluid Specification .....	46
Locking/Unlocking the Tine Depth Setting .....	23	Checking the Transmission Fluid Level .....	46
Adjusting the Operator Weight Control Valve .....	23	Changing the Hydraulic Transmission Filters and Fluid .....	46
Raising the Tines .....	23	Tine Maintenance .....	48
Shutting Off the Engine .....	23	Checking the Tines .....	48
Driving the Machine .....	24	Adjusting the Tine Drive Chain .....	49
Drive-Wheel Release Valves .....	25	Adjusting the Return-to-Up Spring .....	49
After Operation .....	26	Chassis Maintenance .....	50
General Safety .....	26	Check for Loose Hardware .....	50
Loading the Machine .....	26	Cleaning .....	50
Hauling the Machine .....	26	Washing the Machine .....	50
Maintenance .....	28	Cleaning the Engine and the Exhaust System Area .....	50
Maintenance Safety Information .....	28	Removing the Engine Shrouds and Cleaning the Cooling Fins .....	50
Recommended Maintenance Schedule(s) .....	30	Cleaning the Debris from the Machine .....	51
Pre-Maintenance Procedures .....	31	Disposing of Waste .....	51
Preparing for Maintenance .....	31	Storage .....	52
Lubrication .....	31	Troubleshooting .....	53
Lubricating the Chains .....	31	Alert and Error Messages .....	53
Lubricating the Grease Fittings .....	32	Schematics .....	56
Engine Maintenance .....	32		
Servicing the Air Cleaner .....	32		
Servicing the Engine Oil .....	33		
Servicing the Spark Plug .....	35		

# Safety

## Safety Alert Symbol

This Safety Alert Symbol (Figure 3) is used both in this manual and on the machine to identify important safety messages which must be followed to avoid accidents.

This symbol means: **ATTENTION! BECOME ALERT! YOUR SAFETY IS INVOLVED!**



**Figure 3**  
Safety Alert Symbol

g000502

operation, operator controls, and safety signs and instructions to operate the machine. Never let children or untrained people operate or service the equipment. Local regulations may restrict the age of the operator.

- Do Not operate the machine near drop-offs, ditches, embankments, water, or other hazards.
- Do Not put your hands or feet near moving components of the machine.
- Never operate the machine with damaged guards, shields, or covers. Always have safety shields, guards, switches and other devices in place and in proper working condition.
- Stop the machine, shut off the engine, and remove the key before servicing, fueling, or unclogging the machine.

---

The safety alert symbol appears above information which alerts you to unsafe actions or situations and will be followed by the word **DANGER**, **WARNING**, or **CAUTION**.

**DANGER:** Indicates an imminently hazardous situation which, if not avoided, **Will** result in death or serious injury.

**WARNING:** Indicates a potentially hazardous situation which, if not avoided, **Could** result in death or serious injury.

**CAUTION:** Indicates a potentially hazardous situation which, if not avoided, **May** result in minor or moderate injury.

This manual uses two other words to highlight information. **Important** calls attention to special mechanical information and **Note** emphasizes general information worthy of special attention.

## General Safety

This machine is capable of amputating hands and feet and of throwing objects. Toro designs and tests this machine to offer reasonably safe service; however, failure to comply with safety instructions may result in injury or death.

- Read, understand, and follow all instructions and warnings in the Operator's Manual and other training material, on the machine, engine, and attachments. All operators and mechanics should be trained. If the operator(s) or mechanic(s) can not read this manual, it is the owner's responsibility to explain this material to them; other languages may be available on our website.
- Only allow trained, responsible, and physically capable operators that are familiar with the safe

# Safety and Instructional Decals



Safety decals and instructions are easily visible to the operator and are located near any area of potential danger. Replace any decal that is damaged or missing.



115-4212

decal115-4212

1. Hydraulic-fluid level
2. Read the *Operator's Manual*.
3. Warning—do not touch the hot surface.



120-9570

decal120-9570

1. Warning—stay away from moving parts; keep all guards and shields in place.

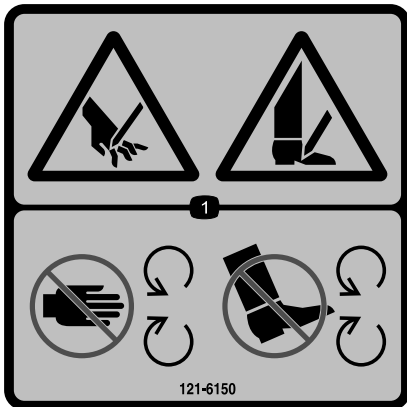

121-6150

decal121-6150

1. Cutting hazard of hand and foot—stay away from moving parts.

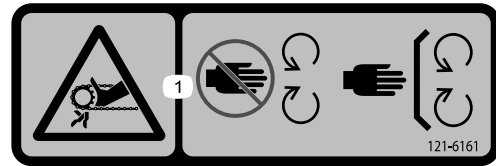

121-6161

decal121-6161

1. Entanglement hazard, belt—stay away from moving parts; keep all guards in place.

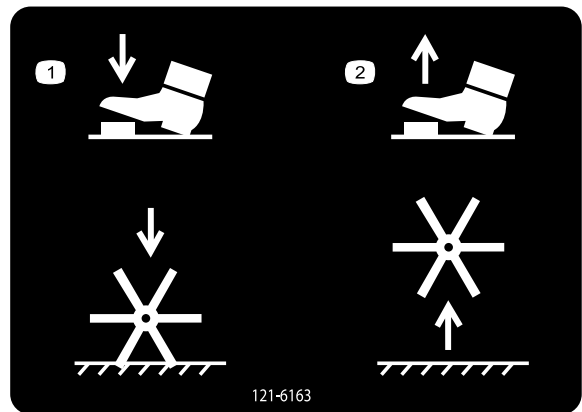

121-6163

decal121-6163

1. Press to lower the tines.
2. Release to raise the tines.

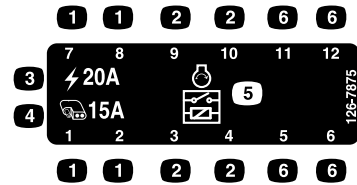

126-7875

decal126-7875

1. Fuse location
2. Relay location
3. Main (20 A)
4. Auxiliary (15 A)
5. Start relay
6. Not used

**⚠ WARNING: Cancer and Reproductive Harm - [www.P65Warnings.ca.gov](http://www.P65Warnings.ca.gov).**  
 For more information, please visit [www.tcoCAProp65.com](http://www.tcoCAProp65.com)  
**CALIFORNIA SPARK ARRESTER WARNING**  
 Operation of this equipment may create sparks that can start fires around dry vegetation. A spark arrester may be required. The operator should contact local fire agencies for laws or regulations relating to fire prevention requirements.

133-8062

decal133-8062

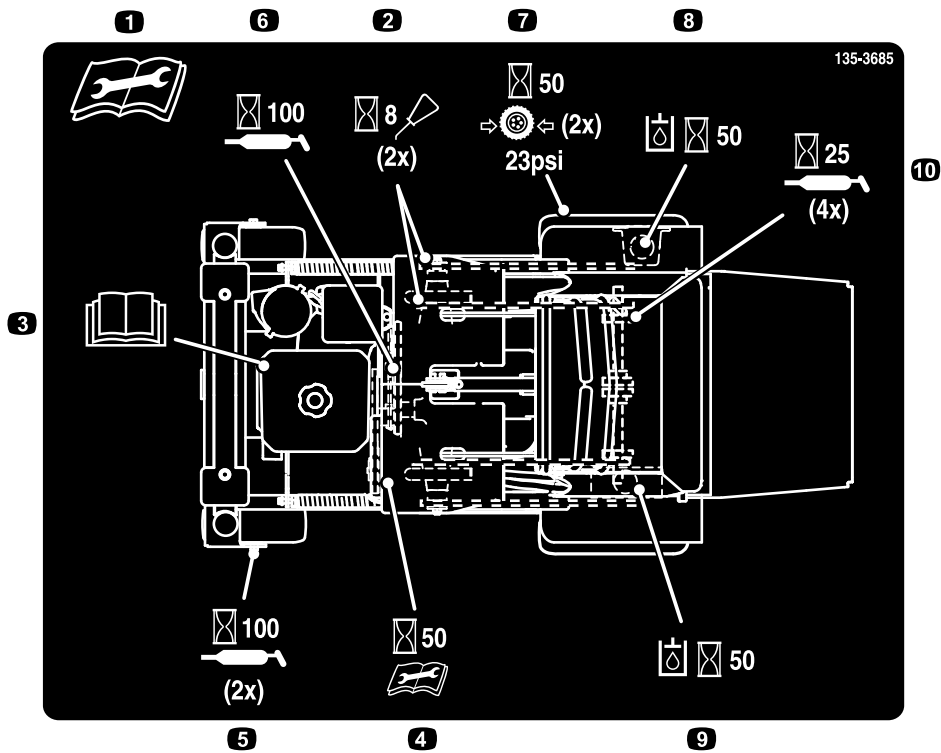

135-3685

decal135-3685

1. Read and understand the *Operator's Manual* before servicing this machine.
2. Clean and oil the chains and check the chain tension every 8 hours
3. See the engine owner's manual for service
4. Check the auxiliary pump drive belt tension every 50 hours
5. Grease the front caster wheel bearings twice every 100 hours
6. Grease the belt idler pivot every 100 hours
7. Check the tire pressure - 23 psi twice every 50 hours
8. Check the hydraulic oil level twice (Use only recommended hydraulic fluid) every 50 hours
9. Check the auxiliary hydraulic tank (Use only AW-32 hydraulic fluid) every 50 hours
10. Grease the tine shaft bearings 4 times every 25 hours

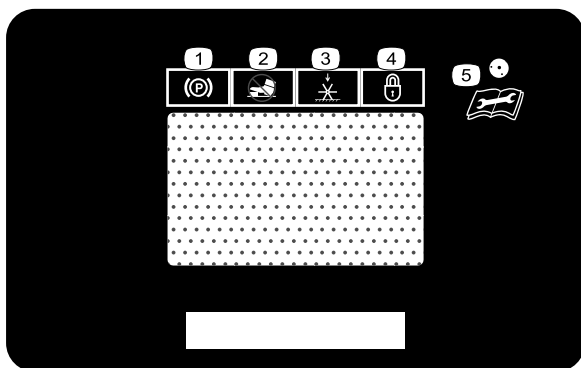

135-1854

decal135-1854

1. Parking brake
2. Tine engagement lockout switch
3. Tines—down
4. Depth setting—lock
5. Read the *Operator's Manual* before performing maintenance.



decal135-2013-1

### 135-2013

- |                               |                  |                           |
|-------------------------------|------------------|---------------------------|
| 1. Operator weight adjustment | 5. Throttle—slow | 9. Parking brake—engage   |
| 2. Increase                   | 6. Engine—on     | 10. Parking brake—release |
| 3. Decrease                   | 7. Engine—start  |                           |
| 4. Throttle—fast              | 8. Engine—off    |                           |

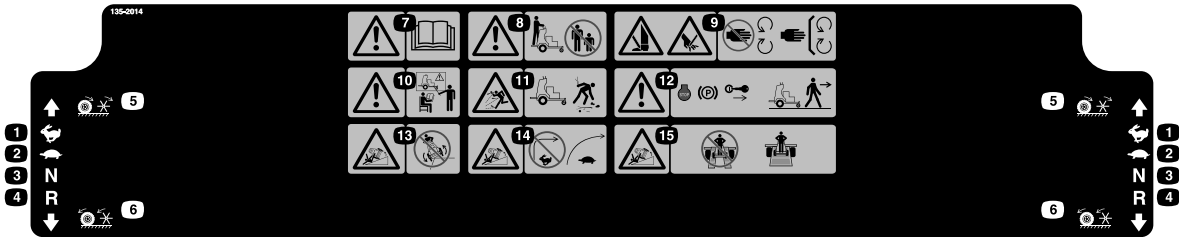

decal135-2014

### 135-2014

- |   |  |  |
|---|--|--|
| 1. Fast   | 6. Wheels and tines rotate when moving backward.   | 11. Thrown object hazard—pick up debris before operating the machine.  |
| 2. Slow   | 7. Warning—read the <i>Operator's Manual</i> .   | 12. Warning—shut off the engine, engage the parking break, and remove the key before leaving the machine.                    |
| 3. Neutral                                      | 8. Warning—keep bystanders away.   | 13. Tipping hazard—do not operate the machine near drop-offs.  |
| 4. Reverse                                      | 9. Cutting/dismemberment hazard of foot; Cutting/dismemberment hazard of hand—stay away from moving parts; keep all guards and shields in place. | 14. Tipping hazard—do not turn sharply while traveling fast; drive slowly when turning.                                      |
| 5. Wheels and tines rotate when moving forward. | 10. Warning—all operators should be trained before operating the machine.  | 15. Tipping hazard—when loading onto a trailer, do not use dual ramps; only use a singular ramp wide enough for the machine. |

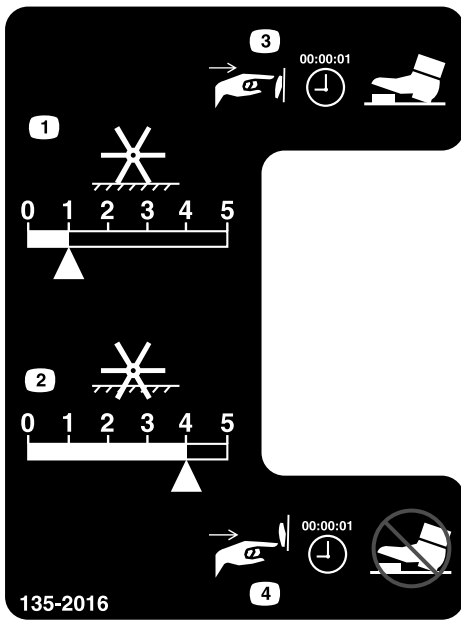

decal135-2016

**135-2016**

1. Electronic tine depth-decrease
2. Electronic tine depth-increase
3. Press and hold 1 second to turn on—tine ground engagement foot switch unlock
4. Press and hold 1 second to turn off—tine ground engagement foot switch lock

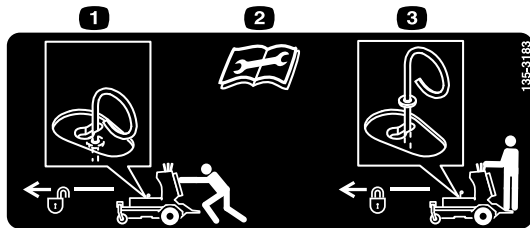

decal135-3183

**135-3183**

1. Bypass lever position for pushing the machine.
2. Read the instructions before servicing or performing maintenance.
3. Bypass lever position for operating the machine.



# Setup

## Loose Parts

Use the chart below to verify that all parts have been shipped.

Procedure	Description	Qty.	Use
<b>3</b>	No parts required	–	Check the battery charge.
<b>4</b>	No parts required	–	Checking the transmission fluid.
<b>5</b>	No parts required	–	Check the auxiliary hydraulic fluid level.

## Media and Additional Parts

Description	Qty.	Use
Operator's Manual	1	Read before operating the machine.
Key	2	Start the machine.

# 1

## Checking Tire Air Pressure

No Parts Required

### Procedure

Check the air pressure in the drive tires, and adjust the pressure as needed; refer to [Checking the Drive Tire Air Pressure \(page 39\)](#).

**Note:** You do not adjust air pressure for the semi-pneumatic caster tires.

# 2

## Servicing the Engine Oil

No Parts Required

### Procedure

The engine is shipped with oil; check the engine-oil level and, if necessary, add oil to the specified level; refer to [Engine-Oil Specifications \(page 33\)](#) and [Checking the Engine-Oil Level \(page 33\)](#).

# 3

## Checking the Battery Charge

No Parts Required

### Procedure

The machine is shipped with a filled, lead-acid battery, Check the charge of the battery and, if necessary, charge it; refer to [Charging the Battery \(page 38\)](#).

# 4

## Checking the Transmission Fluid

No Parts Required

### Procedure

The transmission is shipped with transmission fluid. Check the transmission fluid level and, if necessary, add fluid to the specified level; refer to [Transmission Fluid Specification \(page 46\)](#) and [Checking the Transmission Fluid Level \(page 46\)](#).

# 5

## Check the Auxiliary Hydraulic Fluid Level

No Parts Required

### Procedure

The auxiliary hydraulic reservoir is shipped with hydraulic fluid. Check the hydraulic reservoir fluid level and, if necessary, add fluid to the specified level; refer to [Auxiliary Hydraulic Fluid Specification \(page 44\)](#) and [Checking the Auxiliary Hydraulic Fluid Level \(page 44\)](#).

# Product Overview

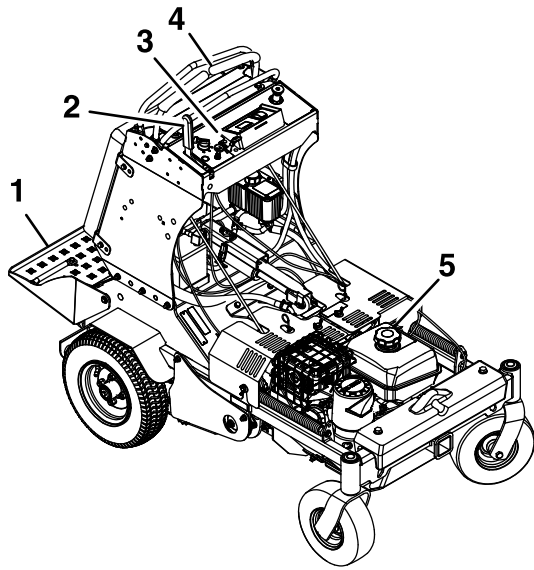

Figure 4

g232039

- |                        |                          |
|------------------------|--------------------------|
| 1. Platform            | 4. Motion-control levers |
| 2. Parking brake lever | 5. Fuel cap              |
| 3. Engine controls     |                          |

# Controls

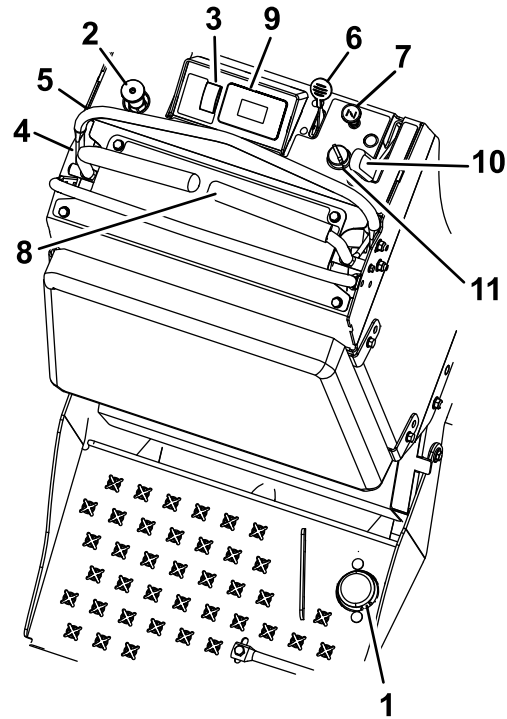

Figure 5

g223341

- |                                       |                               |
|---------------------------------------|-------------------------------|
| 1. Tine ground engagement foot switch | 7. Choke                      |
| 2. Operator weight adjustment control | 8. Right motion-control lever |
| 3. Multi-function switch              | 9. Hour meter                 |
| 4. Left motion-control lever          | 10. Parking-brake handle      |
| 5. Front reference bar                | 11. Ignition switch           |
| 6. Throttle                           |                               |

## Tine Ground Engagement Foot Switch

**Keep your hands and feet away from the tines. Ensure that the tines area is clear of any obstructions before lowering it.**

The switch is located on the operator platform ([Figure 5](#)).

To lower the tines into the ground, stand on the tine ground engagement switch. To raise the tines, remove your foot from the switch.

This switch can be locked out (disabled) with the multi-function switch.

- Tap and hold the bottom of the switch to override and lock out (disable) the foot switch. The LED illuminates in the hour meter/tine engagement display. Use this feature when transporting the aerator.
- To unlock, tap and hold the top of the multi-function switch until the LED light disappears.

**Note:** The lockout feature is engaged each time the engine is switched off.

## Operator Weight Adjustment Control

The operator weight adjustment valve is located at the left side of the control console (Figure 6).

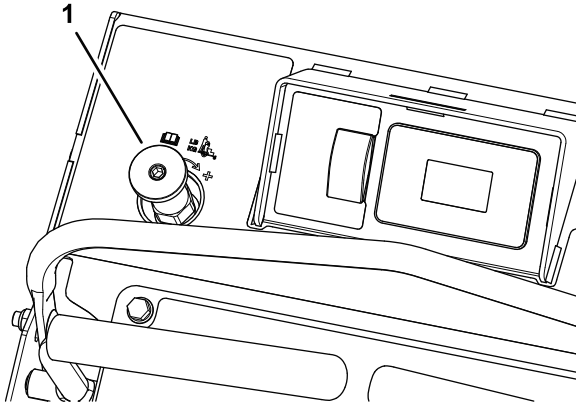

Figure 6

g249578

1. Operator weight adjustment control

Use the operator weight adjustment valve to help compensate for the weight of the operator so that the machine achieves the correct aerating pressure, plug length, and to help maximize lateral machine stability.

**Note:** Each operator must adjust the system pressure so that the drive tires lightly touch the ground.

**Important:** Keep the drive tires on the ground at all times to maximize lateral machine stability.

## Multi-Function Switch

The multi-function switch is located to the left of the hour meter/tine engagement display (Figure 5).

This switch allows the operator to do the following:

- increase or decrease the depth of aeration plug
- lock or unlock the tine depth setting
- reset maintenance service reminder screens

## Motion-Control Levers

The motion-control levers are located on each side of the top console and control the forward and reverse motion of the machine (Figure 7).

Move the levers forward or backward to control the drive wheel on the same side forward or reverse respectively. The wheel speed is proportional to the amount you move the lever.

**Important:** The tines rotate when the motion-control levers are moved out of the NEUTRAL position.

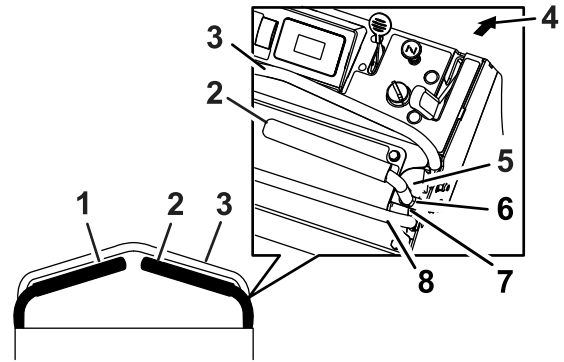

Figure 7

g223330

1. Left motion-control lever
2. Right motion-control lever
3. Front reference bar
4. Front of machine
5. Forward
6. Neutral
7. Reverse
8. Rear reference bar

## Throttle Lever

The throttle lever (Figure 5) is located on the control console (red lever).

Use the throttle lever to control engine speed. Move the throttle lever forward to increase engine speed; moving the throttle lever rearward to decrease the engine speed.

**Note:** Move the throttle lever forward into the detent for full throttle.

## Choke Control

The choke control (Figure 5) is located on the control console.

Use the choke control to aid in starting a cold engine. Pull out the choke control to set the choke to the ON position; press in the choke lever to reduce the choke.

**Note:** Pull out the choke control to set the choke to the ON position.

**Note:** Do not run a warm engine with the choke in the ON position.

## Hour Meter/Tine Engagement Display

### Smart Controller/Electronic Depth Control

The hour meter/tine engagement display is located to the left of the ignition switch on the control console (Figure 5).

Use the hour meter/tine engagement display to show the following information generated by the smart controller/electronic depth control system:

Aerating Hours	Electronic depth control setting indicator for the tines	Parking brake indicator
Alert and Error Messages	Engine Hours	Maintenance Reminders and Alerts
Battery voltage	Interlock status	LED Status Light

Refer to [Using the Smart Controller/Electronic Depth Control \(page 19\)](#) for more information.

### Hour Meter Display

The hour meter ([Figure 8](#)) monitors and displays total engine hours.

**Note:** The engine hours display when the ignition key is in the OFF position or while the engine is running. The engine hours do not display while the machine is aerating.

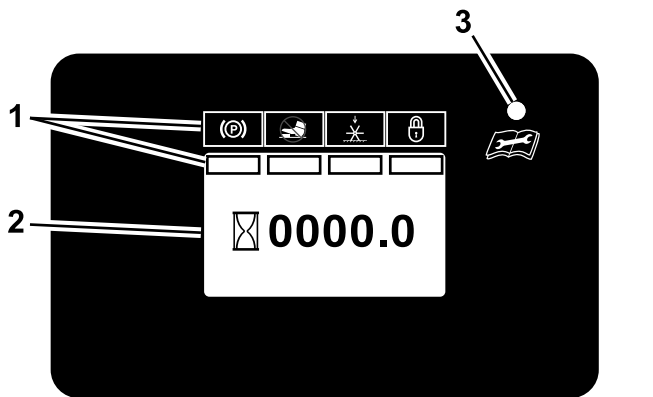

**Figure 8**

g211730

1. LCD Indicators/Information screen
2. Hour display
3. LED status light

### Tine Engagement Display

The tine engagement display ([Figure 9](#)) monitors and shows the electronic tine depth setting.

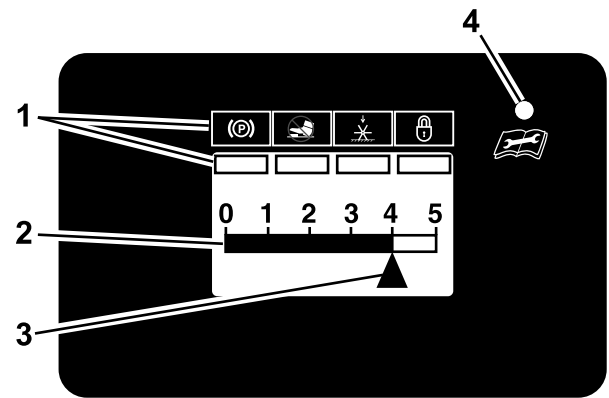

**Figure 9**

g211731

1. LCD Indicators/Information screen
2. Tine depth status bar
3. Tine depth setting indicator
4. LED status light

### LED Status Light

The LED status light is located at the right side of the hour meter/tine engagement display ([Figure 8](#) and [Figure 9](#)).

The LED is multi-colored to indicate the system status.

### Parking-Brake Handle

The parking-brake handle is located on the control console, to the right of the key switch ([Figure 5](#)).

**Note:** The brake handle engages a parking brake in each of the transmissions.

- To engage the parking brake, pull the handle back toward you.
- To release the parking brake, push the handle all the way forward away from you.

When parking on a slope, chock or block the wheels in addition to engaging the parking brake. Tie down the machine and engage the parking brake when transporting the machine.

### Ignition Switch

The Ignition switch is located on the right side of the control console ([Figure 5](#)).

Use the Ignition key to start and shut off the engine. The switch has 3 positions: OFF, ON, and START ([Figure 10](#)).

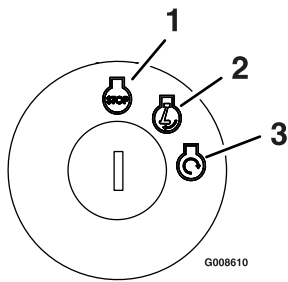

**Figure 10**

1. OFF  
2. ON  
3. START

## Specifications

Height	129.5 cm (51 inches)
Length	173.2 cm (68.6 inches)
Width	90.2 cm (35.5 inches)
RPM (Full Speed)	3800 ± 100 rpm (no load)
Aeration width	61 cm (24 inches)
Coring range	1.3 to 12.7 cm (0.5 to 5 inches)
Holes per square foot	4.6
Tines	36
Weight	388 kg (856 lb)

## Fuel-Shutoff Lever

The fuel-shutoff lever is located under the air cleaner at the front right side of the engine (Figure 11).

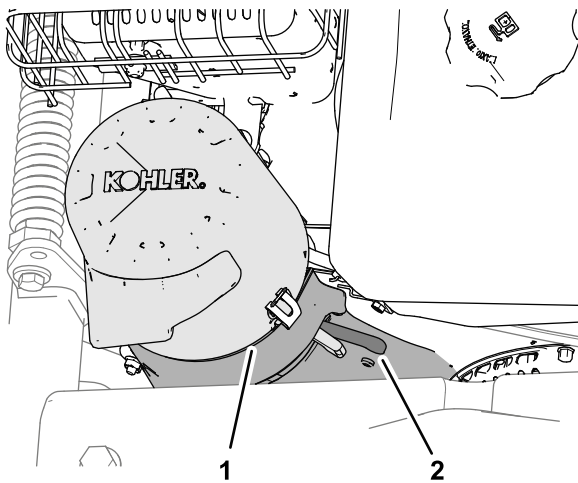

**Figure 11**

1. Air cleaner  
2. Fuel-shutoff lever

A selection of Toro approved attachments and accessories is available for use with the machine to enhance and expand its capabilities. Contact your Authorized Service Dealer or authorized Toro distributor or go to [www.Toro.com](http://www.Toro.com) for a list of all approved attachments and accessories.

To ensure optimum performance and continued safety certification of the machine, use only genuine Toro replacement parts and accessories. Replacement parts and accessories made by other manufacturers could be dangerous, and such use could void the product warranty.

Use the fuel-shutoff lever to shut off the fuel when you are not using the machine for a few days, while you are transporting the machine to and from the jobsite, or when the machine is parked inside a building.

# Operation

## Before Operation

### Before Operation Safety

#### General Safety

##### **⚠ CAUTION**

**This machine produces sound levels in excess of 85 dBA at the operator's ear and can cause hearing loss through extended periods of exposure.**

**Wear hearing protection when operating this machine.**

- Evaluate the terrain to determine what accessories and attachments are needed to properly and safely perform the job. Only use accessories and attachments approved by Toro.
- Inspect the area where the equipment is to be used and remove all rocks, toys, sticks, wires, bones, and other foreign objects. These can be thrown or interfere with the operation of the machine and may cause personal injury to the operator or bystanders.
- Mark and avoid hidden objects such as sprinkler heads, underground wires/cables, invisible fences, etc. to prevent damage to these systems when aerating.
- Wear appropriate personal protective equipment such as safety glasses, substantial slip-resistant footwear, and hearing protection. Tie back long hair and avoid loose clothing and loose jewelry which may get tangled in moving parts.
- Check that the operator presence controls, safety switches, and shields are attached and functioning properly. Do Not operate unless they are functioning properly.
- Do Not operate the machine when people, especially children, or pets are in the area. Stop the machine and attachment(s) if anyone enters the area.
- Do Not operate the machine with damaged guards, shields, or covers. Always have safety shields, guards, switches and other devices in place and in proper working condition. Frequently check for worn or deteriorating components and replace them with the manufacturer's recommended parts when necessary.

#### Fuel Safety

- Use extreme care in handling fuel. It is flammable and its vapors are explosive.
- Extinguish all cigarettes, cigars, pipes, and other sources of ignition.
- Use only an approved fuel container.
- Do not remove the fuel cap or fill the fuel tank while the engine is running or hot.
- Do not add or drain the fuel in an enclosed space.
- Do not store the machine or fuel container where there is an open flame, spark, or pilot light, such as on a water heater or other appliance.
- If you spill fuel, do not attempt to start the engine; avoid creating any source of ignition until the fuel vapors have dissipated.

### Adding Fuel

##### **⚠ DANGER**

**In certain conditions, fuel is extremely flammable and highly explosive. A fire or explosion from fuel can burn you and others and can damage property.**

- **Fill the fuel tank outdoors, in an open area, and when the engine is cold. Wipe up any fuel that spills.**
- **Do not fill the fuel tank completely full. Add fuel to the fuel tank until the level is 6 to 13 mm (1/4 to 1/2 inch) below the bottom of the filler neck. This empty space in the tank allows the fuel to expand.**
- **Never smoke when handling fuel, and stay away from an open flame or where a spark may ignite the fuel fumes.**
- **Store fuel in an approved fuel container and keep it out of the reach of children.**
- **Never buy more than a 30-day supply of fuel.**

##### **⚠ WARNING**

**Fuel is harmful or fatal if swallowed. Long-term exposure to vapors can cause serious injury and illness.**

- **Avoid prolonged breathing of vapors.**
- **Keep your face away from the nozzle and fuel tank or conditioner bottle opening.**
- **Avoid contact with skin; wash off spills with soap and water.**

## Fuel Specification

<b>Petroleum fuel</b>	Use unleaded gasoline with an octane rating of 87 or higher ((R+M)/2 rating method).
<b>Ethanol blended fuel</b>	Use an unleaded-gasoline blend with up to 10% ethanol (gasohol) or 15% MTBE (methyl tertiary butyl ether) by volume is acceptable. Ethanol and MTBE are not the same.  Gasoline with 15% ethanol (E15) by volume is not approved for use. Never use gasoline that contains more than 10% ethanol by volume, such as E15 (contains 15% ethanol), E20 (contains 20% ethanol), or E85 (contains up to 85% ethanol). Using unapproved gasoline may cause performance problems and/or engine damage which may not be covered under warranty.

**Important:** For best results, use only clean, fresh fuel (less than 30 days old).

- Do not use gasoline containing methanol.
- Do not store fuel either in the fuel tank or fuel containers over the winter unless you use a fuel stabilizer.
- Do not add oil to gasoline.

## Using Stabilizer/Conditioner

Use fuel stabilizer/conditioner in the machine at all times to keep the fuel fresh longer when used as directed by the fuel-stabilizer manufacturer.

**Important:** Do not use fuel additives containing methanol or ethanol.

Add the amount of fuel stabilizer/conditioner to fresh fuel as directed by the fuel-stabilizer manufacturer.

## Fueling the Machine

**Fuel-tank capacity:** 7 L (1.9 US gallons)

1. Clean around the fuel-tank cap.
2. Remove the cap from the tank.
3. Fill the fuel tank with fuel to within 6 to 13 mm (1/4 to 1/2 inch) from the top of the tank. **Do not fill into the filler neck.**

**Important:** Do not fill the tank more than 6 mm (1/4 inch) from the top of the tank because the fuel must have room to expand.

4. Install the fuel-tank cap and wipe up any spilled fuel.

## Performing Daily Maintenance

Before starting the machine each day, perform each use/daily maintenance procedures that follow:

- [Lubricating the Chains \(page 31\)](#)
- [Checking the Engine-Oil Level \(page 33\)](#)
- [Checking the Safety Interlock \(page 36\)](#)
- [Checking the Condition of the Chains \(page 40\)](#)
- [Checking the Sprocket Condition \(page 40\)](#)
- [Checking the Tines \(page 48\)](#)
- [Check for Loose Hardware \(page 50\)](#)
- [Cleaning the Engine and the Exhaust System Area \(page 50\)](#)
- [Cleaning the Debris from the Machine \(page 51\)](#)

## Adjusting the Front Reference/Speed Control Bar

Adjust the front reference/speed control bar for desired maximum forward speed.

1. Shut off the engine, engage the parking brake, and move the motion control levers to the neutral position.
2. Loosen the bolts on both sides of the control tower by loosening the 2 nuts on each side (four total) of the console (see [Figure 12](#)).

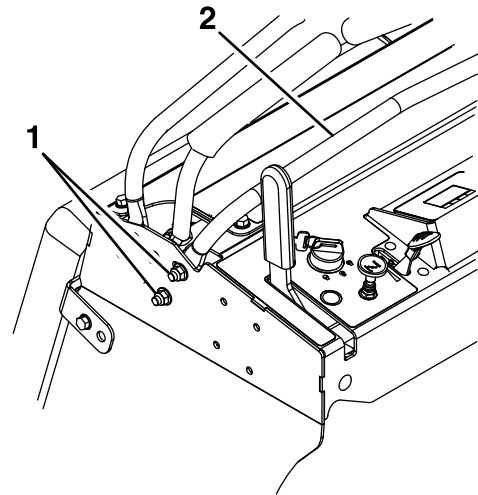

**Figure 12**

1. Nuts
2. Front reference/speed control bar

3. Move the bar forward to obtain the fastest speed. Move the bar backward to obtain the slowest speed.
4. On both sides, tighten the nuts and bolts.

**Important:** Make sure that the nuts and bolts are tight, so the front reference/speed control bar does not move during operation.



# Positioning the Air-Cleaner Cover for Cold or Warm Air Temperature

**Important:** Running the engine with the air-cleaner cover positioned for cold-weather operation in normal conditions can damage the engine.

The air-cleaner cover has 2 positions: the cold or normal, ambient air positions:

Adjust the air-cleaner cover as follows:

- When operating in a **cold ambient air condition** (cold air temperature and humidity)—position the air-cleaner cover with snowflake decal facing out (Figure 13).

**Note:** Use this position if your machine exhibits carburetor icing. Symptoms include the engine runs rough at idle or low speed, and it discharges black or white smoke in the exhaust.

- When operating in a **normal ambient air condition**—position the air-cleaner cover with sun decal facing out (Figure 13).

**Note:** Use this position if your machine is not exhibiting carburetor icing.

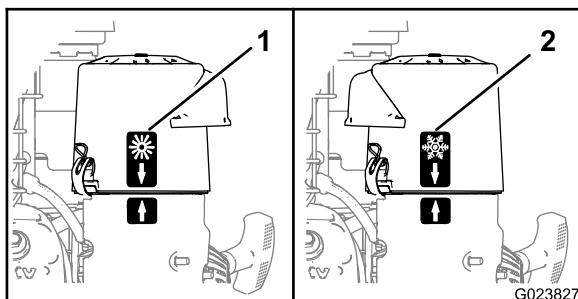

Figure 13

1. Normal ambient air position
2. Cold ambient air position

## During Operation

**Note:** Determine the left and right sides of the machine from the normal operating position.

## During Operation Safety

### General Safety

The operator must use their full attention when operating the machine. **Do Not** engage in any activity that causes distractions; otherwise, injury or property damage may occur.

### ⚠ WARNING

Operating engine parts, especially the muffler, become extremely hot. Severe burns can occur on contact and debris, such as leaves, grass, brush, etc. can catch fire.

- Allow engine parts, especially the muffler, to cool before touching.
- Remove accumulated debris from muffler and engine area.

### ⚠ WARNING

Engine exhaust contains carbon monoxide, which is an odorless deadly poison that can kill you.

**Do Not run engine indoors or in a small confined area where dangerous carbon monoxide fumes can collect.**

- The owner/user can prevent and is responsible for accidents or injuries occurring to himself or herself, other people or property.
- This machine was designed for one operator only. Do not carry passengers and keep all others away from machine during operation.
- Do Not operate the machine under the influence of alcohol or drugs.
- Operate only in daylight or good artificial light.
- Lightning can cause severe injury or death. If lightning is seen or thunder is heard in the area, Do Not operate the machine; seek shelter.
- Use extra care while operating with accessories or attachments. These can change the stability of the machine and cause a loss of control. Follow directions for counter weights if required.
- Keep away from holes, ruts, bumps, rocks, and other hidden hazards. Use care when approaching blind corners, shrubs, trees, tall grass or other objects that may hide obstacles or obscure vision. Uneven terrain could overturn the machine or cause the operator to lose their balance or footing.
- Be sure all drives are in neutral and parking brake is engaged before starting engine.
- Start the engine carefully according to instructions with feet well away from the tines.
- Never operate the machine with damaged guards, shields, or covers. Always have safety shields, guards, switches and other devices in place and in proper working condition.
- Keep clear of the tines at all times.

- Keep hands and feet away from moving parts. If possible, Do Not make adjustments with the engine running.

## **⚠ WARNING**

**Hands, feet, hair, clothing, or accessories can become entangled in rotating parts. Contact with the rotating parts can cause traumatic amputation or severe lacerations.**

- **Do Not operate the machine without guards, shields, and safety devices in place and working properly.**
- **Keep hands, feet, hair, jewelry, or clothing away from rotating parts.**
- Be aware of the discharge path and direct discharge away from others. Avoid discharging material against a wall or obstruction as the material may ricochet back toward the operator. Raise the tines, slow down, and use caution when crossing surfaces other than grass and when transporting the machine to and from the work area.
- Be alert, slow down and use caution when making turns. Look behind and to the side before changing directions. Do Not operate in reverse unless absolutely necessary.
- Do Not change the engine governor setting or overspeed the engine.
- Park the machine on level ground. Stop engine, wait for all moving parts to stop, and remove the spark plug wire(s).
  - Before checking, cleaning or working on the machine.
  - After striking a foreign object or abnormal vibration occurs (inspect the machine for damage and make repairs before restarting and operating the machine).
  - Before clearing blockages.
  - Whenever you leave the machine. Do Not leave a running machine unattended.
- Stop engine, wait for all moving parts to stop:
  - Before refueling.
- Tragic accidents can occur if the operator is not alert to the presence of children. Children are often attracted to the machine and the working activity. Never assume that children will remain where you last saw them.
  - Keep children out of the working area and under the watchful care of another responsible adult, not the operator.

- Be alert and turn the machine off if children enter the area.
- Before and while backing or changing direction, look behind, down, and side-to-side for small children.
- Never allow children to operate the machine.
- Do Not carry children, even with the blades shut off. Children could fall off and be seriously injured or interfere with the safe operation of the machine. Children that have been given rides in the past could suddenly appear in the working area for another ride and be run over or backed over by the machine.

## **Slope Safety**

- Slopes are a major factor related to loss of control and rollover accidents, which can result in severe injury or death. The operator is responsible for safe slope operation. Operating the machine on any slope requires extra caution. Before using the machine on a slope, the operator must:
  - Review and understand the slope instructions in the manual and on the machine.
  - Evaluate the site conditions of the day to determine if the slope is safe for machine operation. Use common sense and good judgment when performing this evaluation. Changes in the terrain, such as moisture, can quickly affect the operation of the machine on a slope.
- Operate across slopes, never up and down. Avoid operation on excessively steep or wet slopes.
- Identify hazards at the base of the slope. Do not operate the machine near drop offs, ditches, embankments, water or other hazards. The machine could suddenly roll over if a wheel goes over the edge or the edge collapses. Keep a safe distance (twice the width of the machine) between the machine and any hazard. Use a walk behind machine or a hand held tool to operate in these areas.

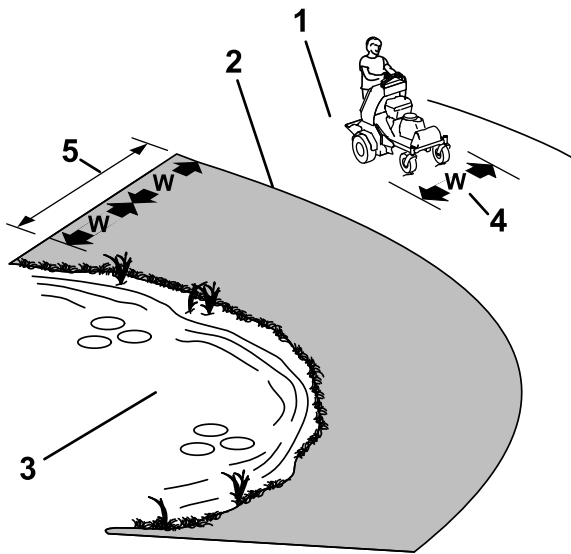

**Figure 14**

g222486

1. Safe Zone — Use the machine here
2. Danger Zone - Use a walk behind machine or a hand held tool near drop offs, ditches, embankments, water or other hazards.
3. Water
4. W=width of the machine
5. Keep a safe distance (twice the width of the machine) between the machine and any hazard.

- Avoid starting, stopping or turning the machine on slopes. Avoid making sudden changes in speed or direction; turn slowly and gradually.
- Do not operate a machine under any conditions where traction, steering or stability is in question. Be aware that operating the machine on wet grass, across slopes or downhill may cause the machine to lose traction. Loss of traction to the drive wheels may result in sliding and a loss of braking and steering. The machine can slide even if the drive wheels are stopped.
- Remove or mark obstacles such as ditches, holes, ruts, bumps, rocks or other hidden hazards. Tall grass can hide obstacles. Uneven terrain could overturn the machine.
- Use extra care while operating with accessories or attachments. These can change the stability of the machine and cause a loss of control. Follow directions for counter weights.
- If you lose control of the machine, step off and away from the direction of travel of the machine.







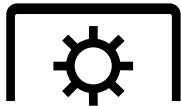

# Using the Smart Controller/Electronic Depth Control

## Hour Meter/Tine Engagement Display

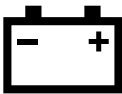
The smart controller/electronic depth control monitors the overall electrical system and displays information in the hour meter/tine engagement display. The controller displays machine hours, interlock status, and maintenance reminders.

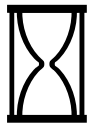
## Screen Icons

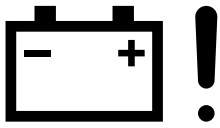
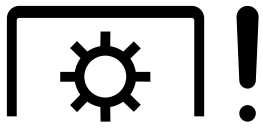
The information screen uses the following icons:

  <p><b>Aerating Hours</b></p>	 <p><b>Parking brake</b></p>
 <p><b>Battery Voltage</b></p>	 <p><b>Engine Oil Maintenance</b></p>
 <p><b>Hour Meter</b></p>	 <p><b>Transmission Oil Maintenance</b></p>
 <p><b>Voltage Error</b></p>	 <p><b>Valve Solenoid Error</b></p>
 <p><b>Valve Solenoid Connection Error</b></p>	

## Information Screens

The main information screens include:

- The Startup Screens
- The Default Screen (engine-on)
- The Tine Engagement Display
- Maintenance Reminders and Alerts
- Alerts and Error Messages

## Start-up Screens

When the key is switched from OFF to RUN position, the following screens display for 2 seconds:

**Note:** The LED status light changes from red to orange to green.

The first screen displays the firmware version.

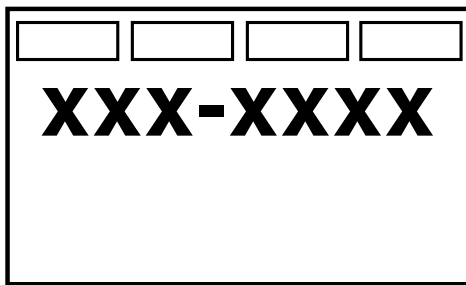

Figure 15

g212116

The second screen displays the aeration hours.

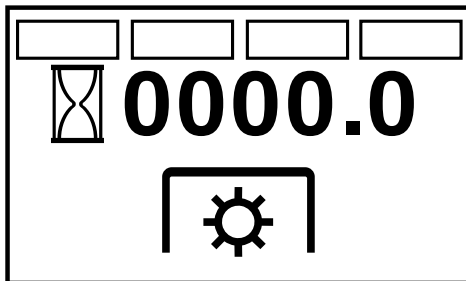

Figure 16

g212114

The third screen displays the electrical system voltage.

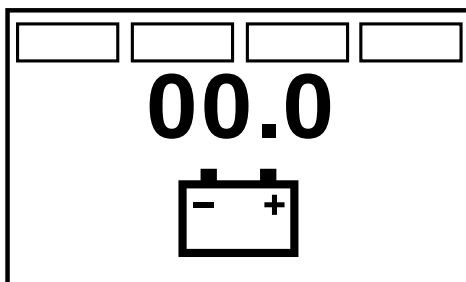

Figure 17

g212115

The fourth screen displays the number of hours until the engine oil maintenance is required.

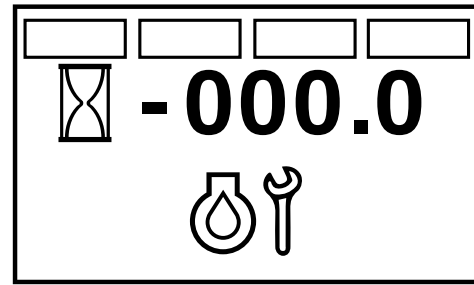

Figure 18

g212117

The final screen displayed is the number of hours until transmission oil maintenance is required.

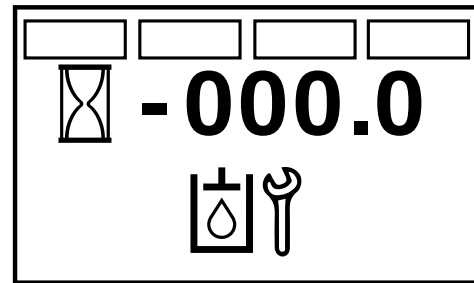

Figure 19

g212118

## The Default Screen

After the start-up screens display, the default screen (Figure 20) appears.

The information screen displays icons and information relative to machine operation.

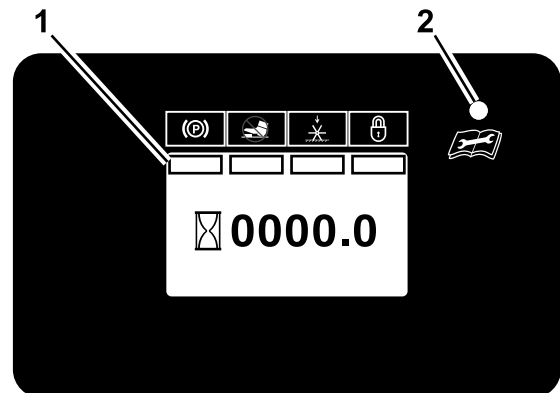

Figure 20  
Default Screen

g211884

1. Information screen
2. LED status light

- The safety interlock status indicator illuminates when the control meets the “safe to start” mode (park brake engaged).

- The hour meter displays engine hours when the hour glass symbol is flashing.
- The display turns off after 5 minutes after the ignition key is switched to the OFF position.

## The Tine Engagement Display

### Electronic Depth Control Screen

There are 2 ways to activate the tine engagement display:

- Tap the multi-function switch either up or down to display the tine engagement meter.
- Step on the tine ground engagement foot switch.

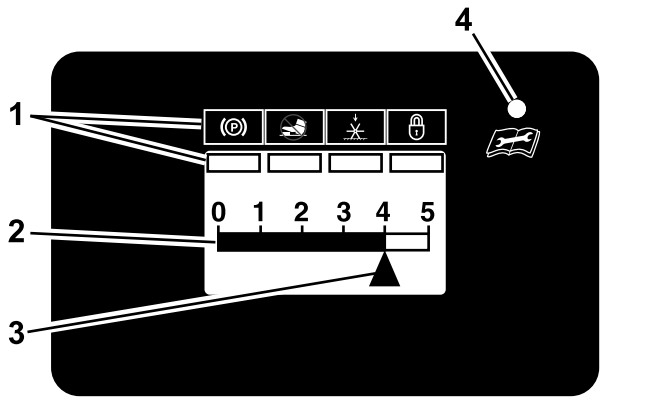

Figure 21

1. LCD Indicators/Information screen
2. Tine depth status bar
3. Tine depth setting indicator
4. LED status light

A higher number on the status bar (Figure 21) increases the length of the aeration plug and a lower number decreases it.

**Note:** If the plug length is not the desired length, you may need to adjust the machine to accommodate for your weight; refer to [Adjusting the Operator Weight Control Valve](#) (page 23).

## LED Status Light

The LED is multi-colored light (Figure 20 and Figure 21) used to indicate the system status:

- **Solid Green**—indicates normal operating activity
- **Blinking Red**—indicates an active fault
- **Solid Red**—indicates that maintenance is required

## Maintenance Reminder Screens

The hour meter displays the number of engine hours until either the engine oil or transmission oil maintenance is due. When maintenance is due, the smart controller/electronic depth control displays flashing icons for an engine oil maintenance alert or a transmission oil maintenance alert, and the LED status light displays a steady red light.

- A maintenance alert occurs when the maintenance counter reaches zero.
- If the service is not performed, the maintenance counter displays time as negative hours to indicate the number of hours past due for the service (up to -500 hours).
- The hour meter switches between the default screen and the active alert screen.
- If more than 1 alert is active, the display cycles between the alerts in the order that they occurred before cycling back to the default screen.

The maintenance alerts only display when the default screen has been active for 2 seconds; however, if the key is moved to the START position, the alerts occur immediately. When the machine is aerating, the alert screen does not display but the LED status light remains a steady red.

## Service Engine Reminder

The engine-oil service reminder (Figure 22) counts down from the initial break-in service interval of 5 engine hours and then counts down from 100 hours for each service interval thereafter.

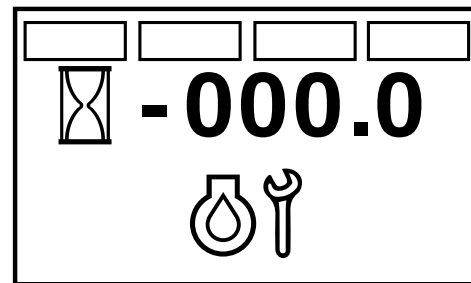

Figure 22

## Service Transmission Reminder

The transmission oil maintenance reminder (Figure 23) counts down from the initial break-in service interval of 100 engine hours and then counts down from 250 hours for each service interval thereafter.

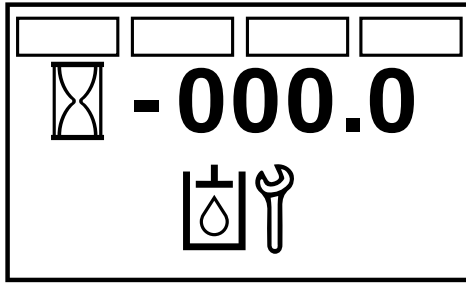

Figure 23

## Opening and Closing the Fuel Shutoff Valve

Control fuel flow to the engine with the fuel shutoff valve as follows:

- To open the fuel-shutoff valve, fully rotate the handle for the valve left.
- To close the fuel-shutoff valve, fully rotate the handle of the valve right.

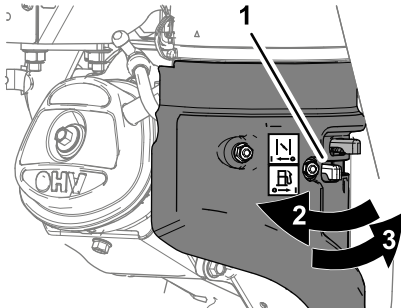

Figure 24

1. Fuel tank
2. Fuel-shutoff valve (open position)
3. Fuel-shutoff valve (closed position)

## Starting the Engine

1. Ensure that the motion-control levers in neutral and the parking brake is engaged.

**Note:** You must engage the park brake and move the motion control levers to the neutral position to start engine.

2. Place the throttle midway between the SLOW and FAST positions.

3. On a cold engine, push the choke lever forward into the ON position. On a warm engine, leave the choke in the OFF position.
4. Turn ignition switch to the START position. Release the switch as soon as the engine starts.

**Important:** Do not crank the engine continuously for more than 10 seconds at a time. If the engine does not start, allow a 60-second cool-down period between starting attempts. Failure to follow these guidelines can burn out the starter motor

5. If the choke is in the ON position, gradually return choke to the OFF position as the engine warms up.

## Lowering the Tines

### ⚠ DANGER

The rotating tines under the engine deck are dangerous. Tine contact can cause serious injury or kill you.

**Do not put hands or feet under the machine when the engine is running.**

1. Set throttle to the FAST position.
2. Tap the switch once to display the tine engagement depth setting; adjust if necessary.
3. Lower the tines by pressing on the tine ground engagement foot switch.
4. Stand on the switch and move the motion-control levers forward to aerate.

**Note:** You can adjust the foot rocker bar, located behind the tine ground engagement foot switch for your comfort. To adjust it, loosen the foot rocker bar hardware, slide the bar forward or rearward, and tighten the hardware.

## Changing the Tine Depth Setting

1. Stop the machine and engage the parking brake.
2. Press the multi-function switch to activate the display.
3. Cycle the key switch between the RUN position and the OFF position 5 times. The tine depth setting indicator (triangle) on the display will begin to flash.
4. Tap the multi-function switch up or down to set the aeration depth. Tap the bottom of the multi-function switch to lower the tine depth to

remove a longer plug. Tap the top of the switch to raise the tine depth to remove a shorter plug.

**Note:** The ideal plug depth is 6.4 to 7.6 cm (2.5 to 3 inches). Adjust the controls to adapt to the soil conditions.

## Locking/Unlocking the Tine Depth Setting

The settings can be locked or left unlocked.

- To lock the setting, Turn the ignition key from the OFF to the ON position 5 times. The LED status light illuminates in the tine engagement display (reference [Figure 21](#)).
- To unlock the setting, press and hold the bottom of the switch for 1 second. The LED status light turns off.

Switch the key to the OFF or START position when you are finished.

## Adjusting the Operator Weight Control Valve

**Note:** Adjust the system pressure so that the drive tires lightly touch the ground.

**Important:** Keep the drive tires on the ground at all times to maximize lateral machine stability.

1. Raise the tines, drive the aerator to a hard, flat turf surface, and stop the aerator, but leave the engine running.
2. Stand on the operator's platform.
3. Press the tine ground engagement foot switch to lower the tines.
  - If the machine raises and the ground tires are no longer touching, rotate the knob for the operator weight adjustment control counterclockwise ([Figure 25](#)) to lower the machine until the tires touch the ground.
  - If the tines are not touching the ground, rotate the knob control clockwise until the tines lower and touch the ground (but not raise the machine).

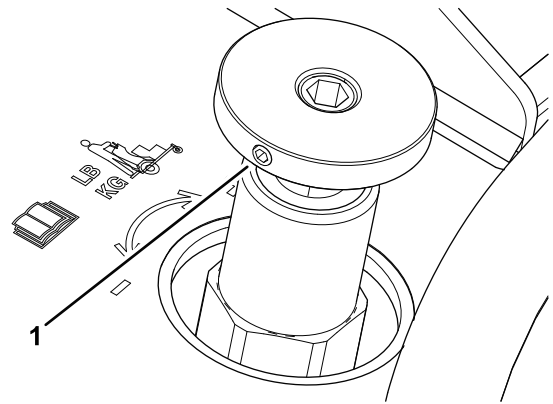

**Figure 25**

g249872

1. Knob (operator weight adjustment control)

**Important:** Keep the drive tires on the ground at all times to maximize lateral machine stability.

4. Release the tine ground engagement foot switch to raise the tines.
5. While holding the position of the knob for the weight control valve, tighten the jam nut.

**Note:** If you are having difficulty maintain the valve adjustment while tightening the jam nut, use a hex key in the shaft of the weight control valve.

## Raising the Tines

1. Remove your foot from the tine ground engagement foot switch
2. Turn the ignition key from the ON position to the OFF position.

**Important:** The tines are rotating when the motion-control lever is moved out of the neutral position.

## Shutting Off the Engine

1. Move the motion-control levers back to the neutral position and bring the machine to a full stop.
2. Lift your foot off of the tine ground engagement foot switch to raise the tines.
3. Press and hold the multi-function switch 1 second lockout the tine ground engagement foot switch.
4. Place the throttle midway between the SLOW and FAST positions.
5. Allow the engine to run for a minimum of 15 seconds, then turn the ignition switch to the OFF position to shut off the engine.

6. Engage the parking brake.
7. Remove the key to prevent children or other unauthorized persons from starting the engine.
8. Close the fuel-shutoff valve when you will not use the machine for a few days, when you are transporting the machine, or when the machine is parked inside a building.

## Driving the Machine

### ⚠ CAUTION

Machine can spin very rapidly by positioning one lever too much ahead of the other. Operator may lose control of the machine, which may cause damage to the machine or injury.

- Use caution when making turns.
- Slow the machine down before making sharp turns.

**Important:** To begin movement (forward or backward), the brake lever must be disengaged (pushed forward) before the motion-control levers can be moved.

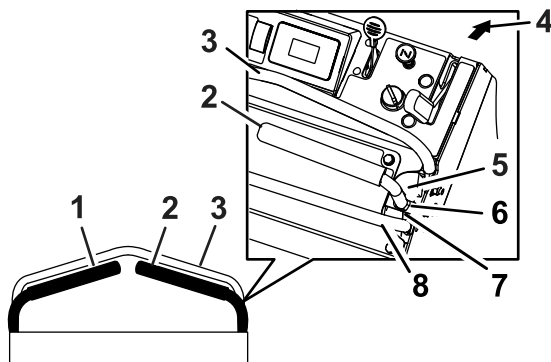

Figure 26

g223330

- |                               |                       |
|-------------------------------|-----------------------|
| 1. Left motion-control lever  | 5. Forward            |
| 2. Right motion-control lever | 6. Neutral            |
| 3. Front reference bar        | 7. Reverse            |
| 4. Front of machine           | 8. Rear reference bar |

### Driving Forward

1. Ensure that the motion-control levers are in the neutral position.
2. Release the parking brake.
3. To move forward in a straight line, move both levers forward with equal pressure.

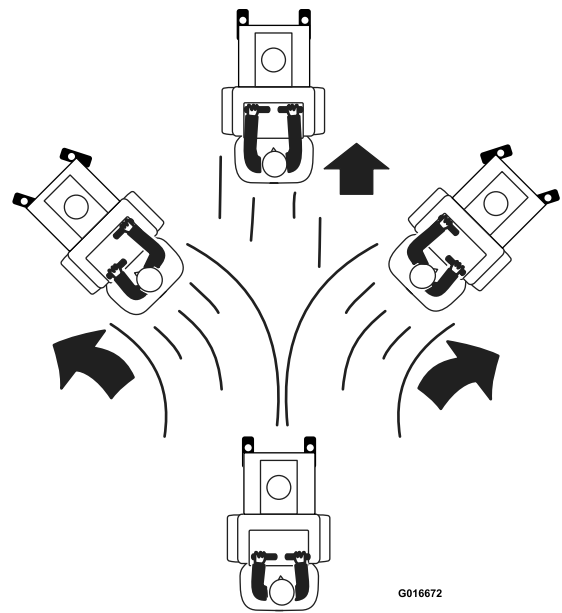

Figure 27

G016672

g016672

To turn left or right, pull the motion-control lever back toward neutral in the desired turn direction. The tines can be in the down position when making gradual turns.

To make zero-degree turns, lift your foot off the tine engagement foot switch control to raise the tines. The head will raise in 1 second.

**Important:** Do not make a zero-degree turn when the tines are down as turf tearing will result.

**Important:** Do not drive in reverse when the tines are down as turf tearing will occur.

The machine moves faster the farther the motion-control levers are moved from the neutral position.

4. To stop, position both motion-control levers in the neutral operating position.

### Driving in Reverse

1. Move the motion-control levers to the neutral operating position.
2. To move rearward in a straight line, slowly move both levers rearward with equal pressure.



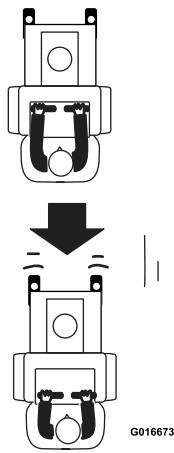

Figure 28

To turn left or right, release pressure on the motion-control lever toward the desired turn direction.

To make zero turns, lift your foot off the tine ground engagement foot switch to raise the tines. The head will raise in half second.

**Important:** Do not make a zero turn when the tines are in the down position.

- To stop, position both motion-control levers in the neutral operating position.

## Drive-Wheel Release Valves

The levers for the drive-wheel release valves are located on the above the transaxles.

### ⚠ WARNING

Hands may become entangled in the rotating drive components between the engine and transaxles, which could result in serious injury or death.

Shut off the engine, remove the key, and allow all the moving parts to stop before accessing the drive-wheel release valves.

### ⚠ WARNING

The engine and hydraulic drive units can become very hot. Touching a hot engine or hydraulic drive units can cause severe burns.

Allow the engine and hydraulic drive units to cool completely before accessing the drive-wheel release valves.

## Releasing Valves to Push the Machine

If you must push the machine by hand, you must release the drive-wheel release valves.

- Engage the parking brake, shut off the engine, remove the key, and allow all the moving parts to stop.
- Move the lever to the larger opening of the slot (Figure 29).

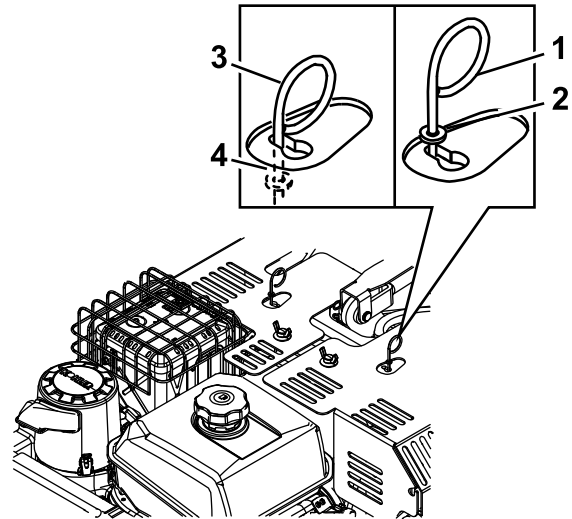

Figure 29

- Lever position for operating the machine
- Washer outside of slot
- Lever position to push the machine
- Washer inside slot

- Push the lever downward until the washer is inside of the frame (Figure 29).
- Move the lever to the narrow portion of the slot, and release the lever (Figure 29).
- Repeat steps 2 through 4 for the other release-valve lever.
- When you are ready to move the machine, release the parking brake.

You can now push the machine by hand.

**Important:** Do not tow the machine.

## Setting the Valves for Normal Operation

During normal operating conditions, the washer on the 2 release-valve levers are positioned outside the slots.

- Engage the parking brake, shut off the engine, remove the key, and allow all the moving parts to stop.
- Move the release-valve lever to the larger opening of the slot (Figure 29).

3. Pull the lever upward until the washer is outside of the frame (Figure 29).
4. Move the release-valve lever back to the narrow portion of the slot, and release the lever (Figure 29).
5. Repeat steps 2 through 4 for the other release-valve lever.

## After Operation

### General Safety

- Park machine on level ground, disengage drives, set parking brake, stop engine, remove key or disconnect spark plug wire. Wait for all movement to stop and allow the machine to cool before adjusting, cleaning, repairing, or storing. Never allow untrained personnel to service machine.
- Clean the machine as stated in the Maintenance section. Keep engine and engine area free from accumulation of grass, leaves, excessive grease or oil, and other debris which can accumulate in these areas. These materials can become combustible and may result in a fire.
- Frequently check for worn or deteriorating components that could create a hazard. Tighten loose hardware.

### Loading the Machine

Use extreme caution when loading machines on trailers or trucks. Use a full-width ramp to extend beyond the rear tires instead of individual ramps for each side of the machine. With the platform up, a full-width ramp provides a surface to walk on behind the machine.

A steep ramp angle may cause components to get caught as the machine moves from ramp to trailer or truck. Steeper angles may also cause the machine to tip backward. If loading on or near a slope, position the trailer or truck so that it is on the down side of the slope and the ramps extends up the slope. This minimizes the ramp angle. The trailer or truck should be as level as possible.

**Important:** Do not attempt to turn the machine while on the ramp, you may lose control and drive off the side.

Avoid sudden acceleration when driving up a ramp and sudden deceleration when backing down a ramp. Both maneuvers can cause the machine to tip backward.

## Hauling the Machine

Use a heavy-duty trailer or truck to transport the machine. Ensure that the trailer or truck has all the necessary lighting and marking as required by law. When using a trailer, secure it with the safety chains.

1. Load the machine onto the transport vehicle.
2. Lock the tines in the up position by tapping and holding the multi-function switch in the down position until the LED indicator appears on the hour meter/tine engagement display.
3. Engage the parking brake, shut off the engine, and remove the key.
4. Close the fuel-shutoff valve.
5. Block the wheels and securely bind the machine to the trailer or truck with straps, chains, cable, or ropes. If possible, both front and rear straps should be directed down and outward from the machine.

**Important:** Use only the 4 designated tie-down locations on the machine—2 on the left side and 2 on the right; refer to Figure 30.

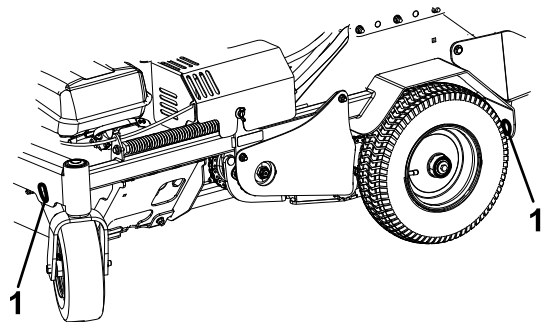

**Figure 30**  
Left side shown

g212139

1. Tie-down location

### ⚠ CAUTION

**This machine does not have proper turn signals, lights, reflective markings, or a slow-moving-vehicle emblem. Driving on a street or roadway without such equipment is dangerous and can lead to accidents causing personal injury. Driving on a street or roadway without such equipment may also be a violation of state laws and the operator may be subject to traffic tickets and/or fines.**

**Do not drive the machine on a public street or roadway.**

## **⚠ WARNING**

**Loading a machine on a trailer or truck increases the possibility of backward tip-over. Backward tip-over could cause serious injury or death.**

- **Use extreme caution when operating a machine on a ramp.**
- **Use only a single, full-width ramp; Do not use individual ramps for each side of the machine.**
- **Avoid sudden acceleration or deceleration while driving machine up or down a ramp to avoid tipping backward.**

# Maintenance

Download a free copy of the electrical or hydraulic schematic by visiting [www.Toro.com](http://www.Toro.com) and searching for your machine from the Manuals link on the home page.

## Maintenance Safety Information

### **⚠ WARNING**

While maintenance or adjustments are being made, someone could start the engine. Accidental starting of the engine could seriously injure you or other bystanders.

Remove the key from the ignition switch, engage parking brake, and pull the wire(s) off the spark plug(s) before you do any maintenance. Also push the wire(s) aside so it does not accidentally contact the spark plug(s).

- Park machine on level ground, raise the tines, set parking brake, stop engine, remove key or disconnect spark plug wire. Wait for all movement to stop and allow the machine to cool before adjusting, cleaning or repairing. Never allow untrained personnel to service machine.

### **⚠ WARNING**

The engine can become very hot. Touching a hot engine can cause severe burns.

Allow the engine to cool completely before service or making repairs around the engine area.

- Disconnect battery or remove spark plug wire before making any repairs. Disconnect the negative terminal first and the positive last. Reconnect positive first and negative last.
- Keep the machine, guards, shields and all safety devices in place and in safe working condition. Frequently check for worn or deteriorating components and replace them with the manufacturer's recommended parts when necessary.

### **⚠ WARNING**

Removal or modification of original equipment, parts and/or accessories may alter the warranty, controllability, and safety of the machine. Unauthorized modifications to the original equipment or failure to use original Toro parts could lead to serious injury or death. Unauthorized changes to the machine, engine, fuel or venting system, may violate applicable safety standards such as: ANSI, OSHA and NFPA and/or government regulations such as EPA and CARB.

- Use care when checking and servicing tines. Wrap the tine(s) or wear gloves, and use caution when servicing them. Only replace damaged tines. Never straighten or weld them.
- Use jack stands to support the machine and/or components when required.

### **⚠ CAUTION**

Raising the machine for service or maintenance relying solely on mechanical or hydraulic jacks could be dangerous. The mechanical or hydraulic jacks may not be enough support or may malfunction allowing the machine to fall, which could cause injury.

Do not rely solely on mechanical or hydraulic jacks for support. Use adequate jack stands or equivalent support.

- Carefully release pressure from components with stored energy.

## **⚠ WARNING**

Hydraulic fluid escaping under pressure can penetrate skin and cause injury. Fluid accidentally injected into the skin must be surgically removed within a few hours by a doctor familiar with this form of injury or gangrene may result.

- If equipped, make sure all hydraulic fluid hoses and lines are in good condition and all hydraulic connections and fittings are tight before applying pressure to hydraulic system.
- Keep body and hands away from pinhole leaks or nozzles that eject high pressure hydraulic fluid.
- Use cardboard or paper, not your hands, to find hydraulic leaks.
- Before performing any work on the hydraulic system:
  - Safely relieve all pressure in the ground drive hydraulic system by placing the motion control levers in neutral and shutting off the engine.
  - Safely relieve all pressure in the auxiliary hydraulic system by shutting off the engine, turning the ignition switch to the “ON” position, and pressing the tine ground engagement switch. Once the tines have lowered to the ground, release the tine ground engagement switch and turn the ignition switch to the “OFF” position.
- Keep hands and feet away from moving parts. If possible, Do Not make adjustments with the engine running. If the maintenance or adjustment procedure require the engine to be running and components moving, use extreme caution.

## **⚠ WARNING**

Contact with moving parts or hot surfaces may cause personal injury.

**Keep your fingers, hands, and clothing clear of rotating components and hot surfaces.**

- Check all bolts frequently to maintain proper tightness.

# Recommended Maintenance Schedule(s)

Maintenance Service Interval	Maintenance Procedure
After the first 5 hours	<ul style="list-style-type: none"> <li>• Change the engine oil.</li> <li>• Check the transmission output shaft nut torque specification.</li> <li>• Check transmission mount bolt torque.</li> </ul>
After the first 100 hours	<ul style="list-style-type: none"> <li>• Change the auxiliary hydraulic reservoir filter and fluid.</li> <li>• Change the hydraulic transmission filter and fluid.</li> </ul>
Before each use or daily	<ul style="list-style-type: none"> <li>• Lubricate the chains.</li> <li>• Check the engine-oil level.</li> <li>• Check the safety interlock.</li> <li>• Check the condition and tension of the chains.</li> <li>• Check the condition of the sprockets.</li> <li>• Check the tines.</li> <li>• Check for loose hardware.</li> <li>• Clean the engine and the exhaust system area (more often in dry or dirty conditions).</li> <li>• Clean the grass and debris buildup from the machine.</li> </ul>
Every 25 hours	<ul style="list-style-type: none"> <li>• Grease the front wheel bearings.</li> <li>• Grease tine shaft bearings.</li> <li>• Grease hydro output shaft flanged bearings.</li> </ul>
Every 50 hours	<ul style="list-style-type: none"> <li>• Clean the foam pre-cleaner (more frequently in dusty conditions).</li> <li>• Check spark arrester (if equipped).</li> <li>• Check the air pressure in the drive tires.</li> <li>• Check the condition and tension of the belts.</li> <li>• Check the transmission fluid level.</li> </ul>
Every 80 hours	<ul style="list-style-type: none"> <li>• Remove the engine shrouds and clean the cooling fins.</li> </ul>
Every 100 hours	<ul style="list-style-type: none"> <li>• Change the engine oil. (more often under severe conditions.)</li> </ul>
Every 160 hours	<ul style="list-style-type: none"> <li>• Check, clean and gap the spark plug.</li> </ul>
Every 200 hours	<ul style="list-style-type: none"> <li>• Replace the foam pre-cleaner.</li> </ul>
Every 250 hours	<ul style="list-style-type: none"> <li>• Change the auxiliary hydraulic reservoir filter and fluid.</li> <li>• Change the hydraulic transmission filter and fluid.</li> </ul>
Every 300 hours	<ul style="list-style-type: none"> <li>• Replace the paper air filter (more frequently in dusty conditions).</li> </ul>
Monthly	<ul style="list-style-type: none"> <li>• Service the battery.</li> </ul>
Yearly	<ul style="list-style-type: none"> <li>• Grease belt idler pivot.</li> <li>• Grease front caster hubs.</li> <li>• Check the torque of the wheel hub bolts.</li> <li>• Check the torque on the wheel lug nuts.</li> <li>• Check the torque of the transmission output shaft nut.</li> <li>• Check transmission mount bolt torque.</li> </ul>
Yearly or before storage	<ul style="list-style-type: none"> <li>• Touch up areas with chipped paint.</li> </ul>

# Pre-Maintenance Procedures

## ⚠ CAUTION

Raising the machine for service or maintenance relying solely on mechanical or hydraulic jacks could be dangerous. The mechanical or hydraulic jacks may not be enough support or may malfunction allowing the machine to fall, which could cause injury.

Do not rely solely on mechanical or hydraulic jacks for support. Use adequate jack stands or equivalent support.

## Preparing for Maintenance

1. Park the machine on a level surface and engage the parking brake.
2. Shut off the engine, remove the key, and wait for all moving parts to stop.
3. Allow the engine to cool.
4. Disconnect the spark-plug wire from the spark plug and keep the wire away from the plug, to prevent accidental starting (Figure 31).

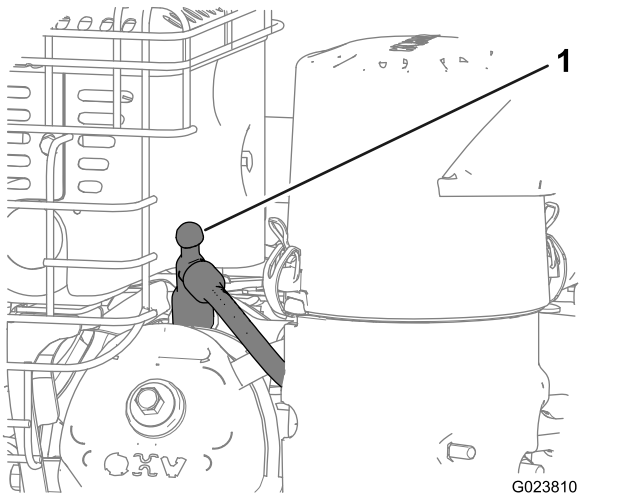

Figure 31

1. Spark-plug wire

# Lubrication

## Lubricating the Chains

Service Interval: Before each use or daily

**Important:** Do not lubricate the chains with penetrating oil or solvents. Use an oil or chain lubricant.

1. Shut off the engine, wait for all moving parts to stop, and remove the key. Engage the parking brake.
2. Lift the rear of the machine and support using jack stands or equivalent support.

## ⚠ CAUTION

Raising the machine for service or maintenance relying solely on mechanical or hydraulic jacks could be dangerous. The mechanical or hydraulic jacks may not be enough support or may malfunction allowing the machine to fall, which could cause injury.

Do not rely solely on mechanical or hydraulic jacks for support. Use adequate jack stands or equivalent support.

3. Start the engine and move throttle control ahead to 1/2 throttle position. Disengage the parking brake.

## ⚠ WARNING

The engine must be running and the drive wheels must be turning so that adjustments can be performed. Contact with moving parts or hot surfaces may cause personal injury.

Keep your fingers, hands, and clothing clear of rotating components and hot surfaces.

4. With the engine running, slowly move the motion-control levers forward and lubricate all 4 chains.
5. Check the condition and tension of the chains; refer to [Checking the Condition of the Chains](#) (page 40).

# Lubricating the Grease Fittings

**Note:** See the chart below for service intervals.

1. Shut off the engine, wait for all moving parts to stop, and remove the key. Engage the parking brake.
2. Lubricate the fittings with NLGI grade No. 2 multi-purpose grease.

Refer to the following chart for fitting locations and lubrication schedule.

## Lubrication Chart

Fitting Locations	Initial Pumps	Number of Places	Service Interval
1. Front Wheel Caster Hubs	1	2	Yearly
2. Tine Shaft Bearings	1	4	25 hours
3. Belt Idler Pivot	1	1	Yearly

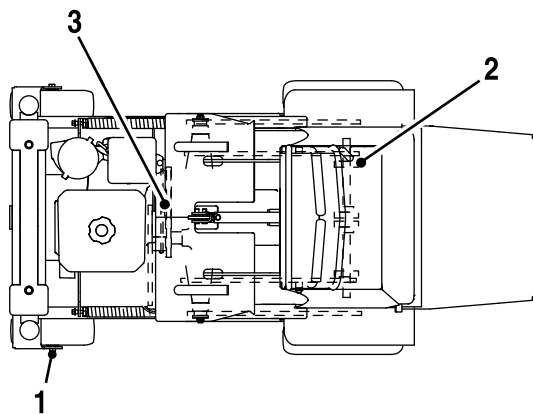

**Figure 32**

1. Front wheel caster hub
2. Tine shaft bearings
3. Belt idler pivot

g230394

# Engine Maintenance

## Servicing the Air Cleaner

**Service Interval:** Every 50 hours—Clean the foam pre-cleaner (more frequently in dusty conditions).

Every 200 hours—Replace the foam pre-cleaner.

Every 300 hours—Replace the paper air filter (more frequently in dusty conditions).

**Important:** Do not operate the engine without the air filter assembly; extreme engine damage may occur.

1. Release the latches on the cover for the air cleaner.
2. Remove the cover and clean it thoroughly (Figure 33).

**Note:** Be careful to prevent dirt and debris from falling into the base.

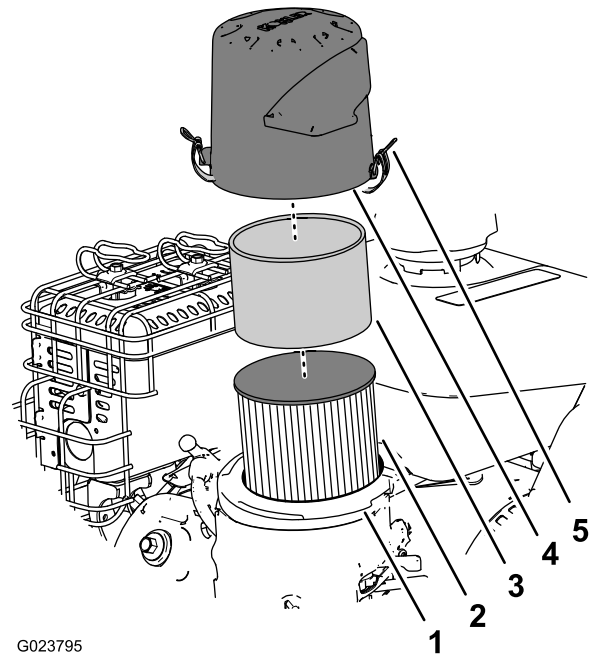

G023795

g023795

**Figure 33**

1. Air-filter base
2. Paper air filter
3. Foam pre-cleaner
4. Cover
5. Latch on the air-cleaner cover (2)

3. Remove the foam pre-cleaner, wash it with a mild detergent and water, and then blot it dry (Figure 33).

4. Remove and inspect the paper air filter (Figure 33); discard it if it is excessively dirty.

**Important:** Do not try to clean a paper filter.



- Wipe dirt away from the base and the cover with a moist rag.

**Note:** Be careful to prevent dirt and debris from entering the air duct leading to the carburetor.

- Install the foam pre-cleaner onto the paper air filter (Figure 33).

**Note:** Use a new paper air filter if you discarded the old one.

- Install the air filter assembly to the air-filter base (Figure 33).
- Align the arrow decal on the air-cleaner cover and the arrow decal on the base (Figure 34).

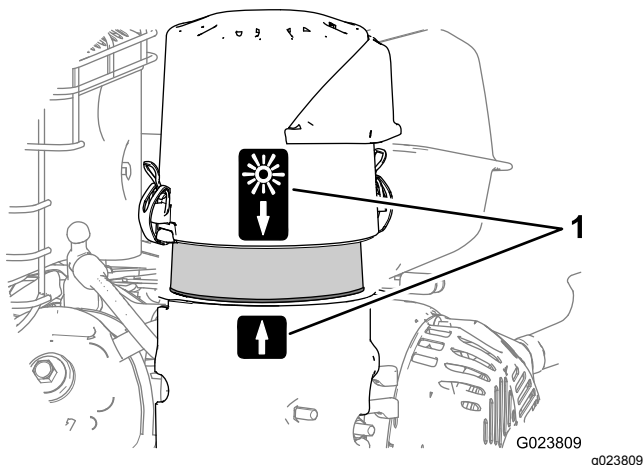

Figure 34

- Alignment-arrow decal (normal ambient air position shown)

- Secure the air-filter cover to the base with the latches.

## Servicing the Engine Oil

### Engine-Oil Specifications

**Oil Type:** Detergent oil (API service SJ or later)

**Engine Oil Capacity:** 1.7 L (1.8 US qt) without the filter; 1.5 L (1.6 US qt) with the filter.

**Oil viscosity:** Refer to the table below.

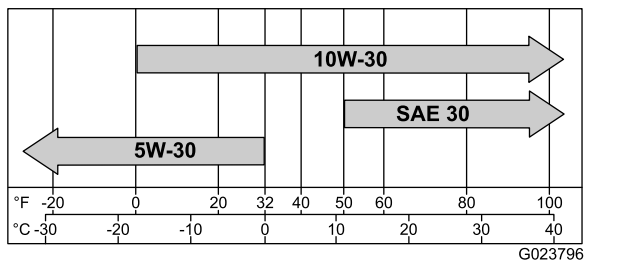

Figure 35

## Checking the Engine-Oil Level

**Service Interval:** Before each use or daily

**Important:** Do not operate the engine with the oil level below the Low (or Add) mark on the dipstick, or over the Full mark.

- Move the machine to a level surface.
- Shut off the engine, engage the parking brake, remove the key, and wait for all moving parts to stop before leaving the operating position.
- Allow the engine to cool.
- Check the engine-oil level as shown in Figure 36.

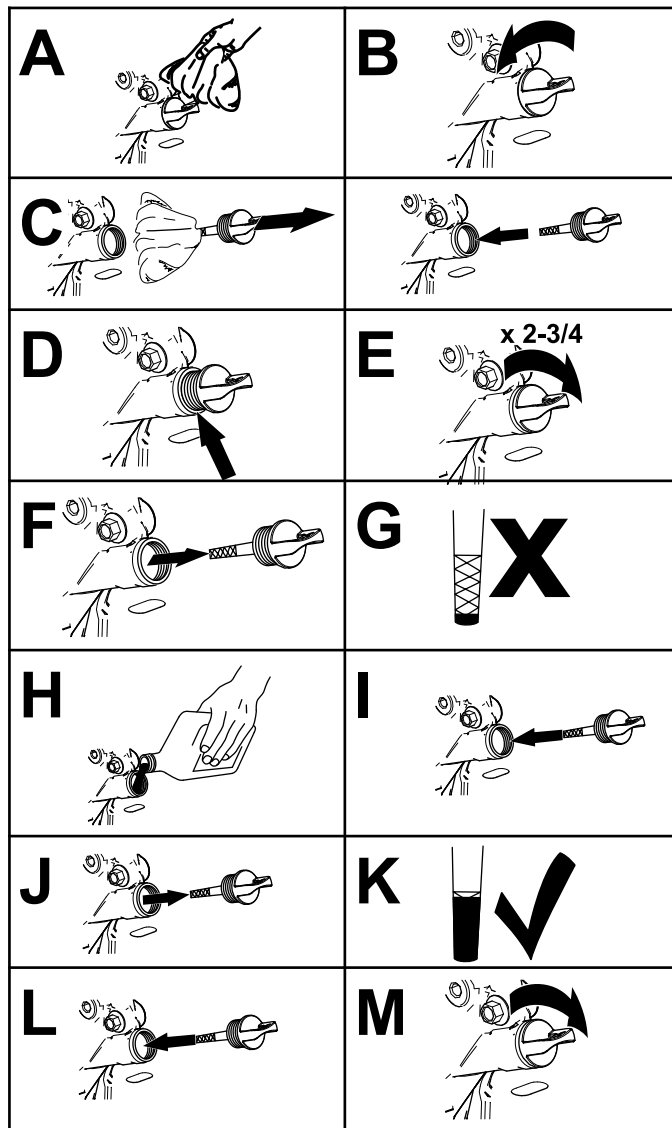

Figure 36

- If the oil level is low, wipe off the area around the oil fill cap, remove cap and add the specified oil until the oil level is at the Full mark on the dipstick.

**Note:** Do not overfill the engine with oil.

# Changing the Engine Oil

**Service Interval:** After the first 5 hours

Every 100 hours (more often under severe conditions.)

**Note:** Dispose of the used oil at a recycling center.

1. Park the machine so that the drain side is slightly lower than the opposite side to assure the oil drains completely.
2. Shut off the engine, engage the parking brake, remove the key, and wait for all moving parts to stop before leaving the operating position.
3. Change the engine oil as shown in [Figure 37](#).

**Note:** Torque drain plug to 18 N·m (13 ft-lb).

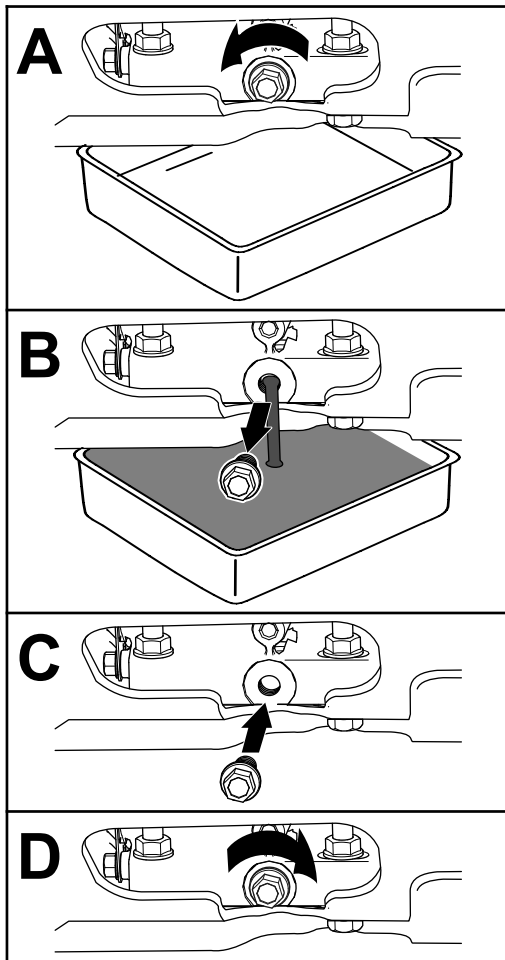

**Figure 37**

g249685

4. Slowly pour approximately 80% of the specified oil into the filler tube, and slowly add the additional oil to bring it to the **Full** mark ([Figure 38](#)).

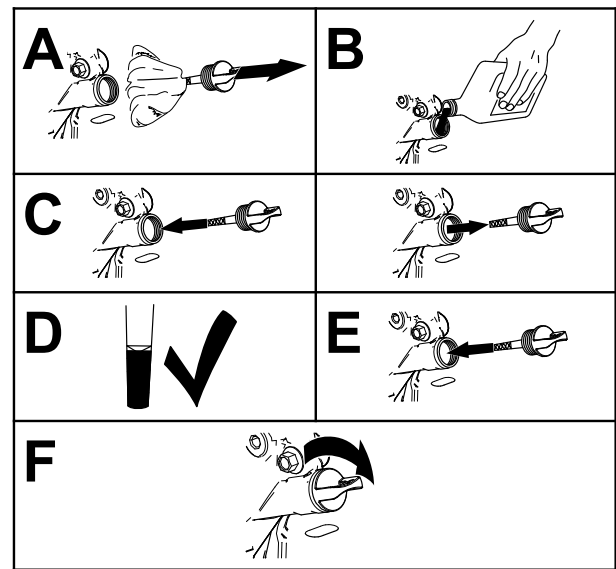

**Figure 38**

g249684

5. Start the engine and drive to a flat area.
6. Check the engine-oil level.
7. Reset the engine-oil service reminder; refer to [Resetting the Engine-Oil Maintenance Reminder](#) (page 34).

## Resetting the Engine-Oil Maintenance Reminder

1. Prepare the machine for maintenance; refer to [Preparing for Maintenance](#) (page 31).
- Note:** You must engage the parking brake to reset the maintenance reminder.
2. Cycle the key switch between the RUN position and the OFF position 4 times within 8 seconds.

The Service Engine screen displays and flashes ([Figure 39](#)).

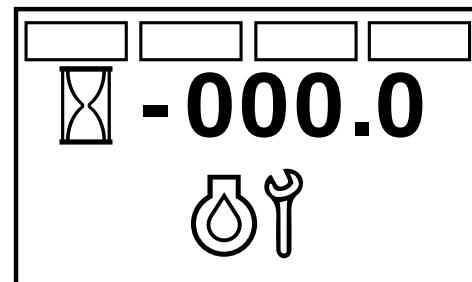

**Figure 39**

Service Engine Screen

g212117

3. Press down the multi-function switch.

The engine-oil maintenance reminder resets to 100.0 (hours), exits the Service Engine screen, and returns to the default screen.

**Note:** You can exit the Service Engine screen at any time by turning the key to either the OFF or the START positions.

## Servicing the Spark Plug

**Service Interval:** Every 160 hours

**Type for all Engines:** NGK BR6HS, Champion RTL86C, or equivalent

**Air Gap:** 0.76 mm (0.030 inch)

Ensure that the air gap between the center and side electrodes is correct before installing the spark plug.

Use a spark plug wrench for removing and installing the spark plug(s) and a gapping tool/feeler gauge to check and adjust the air gap. Install a new spark plug(s) if necessary.

### Removing the Spark Plug

1. Shut off the engine, engage the parking brake, remove the key, and wait for all moving parts to stop before leaving the operating position.
2. Remove the spark plug as shown in [Figure 40](#).

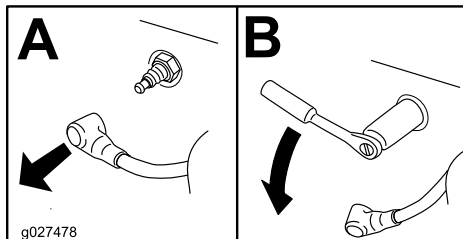

Figure 40

g027478

### Checking the Spark Plug

**Important:** Do not clean the spark plug(s). Always replace the spark plug(s) when it has a black coating, worn electrodes, an oily film, or cracks.

If you see light brown or gray on the insulator, the engine is operating properly. A black coating on the insulator usually means the air cleaner is dirty.

Set the gap to 0.75 mm (0.03 inch).

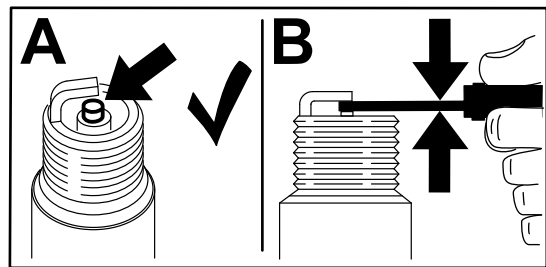

Figure 41

g206628

### Installing the Spark Plug

Tighten the spark plug(s) to 22 N·m (16 ft·lb).

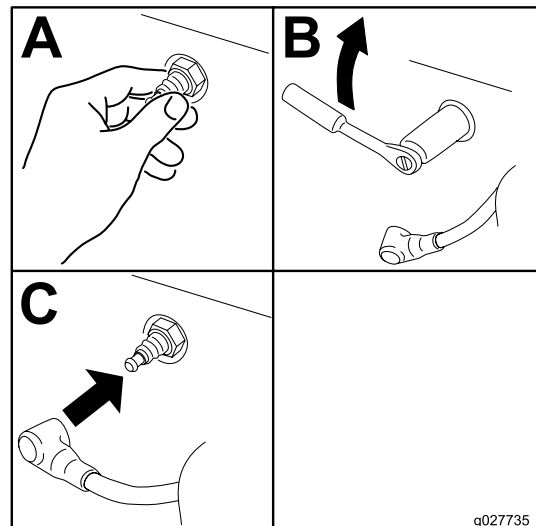

Figure 42

g027735

# Checking the Spark Arrester

## Machines with a Spark Arrester Only

Service Interval: Every 50 hours

### **⚠ WARNING**

Hot exhaust system components may ignite fuel vapors even after the engine is shut off. Hot particles exhausted during engine operation may ignite flammable materials. Fire may result in personal injury or property damage.

Do not refuel or run engine unless a spark arrester is installed.

1. Shut off the engine, engage the parking brake, remove the key, and wait for all moving parts to stop before leaving the operating position.
2. Allow the muffler to cool.
3. Check the spark arrester for breaks in the screen or welds.

**Note:** Replace the spark arrester if it is worn or damaged.

4. If you see that the screen is plugged, perform the following:
  - A. Remove the spark arrester.
  - B. Shake loose the particles from the arrester and clean screen with a wire brush.  
**Note:** Soak the arrester screen in solvent if necessary.
  - C. Install spark arrester onto exhaust outlet.

# Electrical System Maintenance

## Checking the Safety Interlock



Service Interval: Before each use or daily

**Important:** Ensure that the operator safety mechanisms are connected and are fully function prior to use.

**Note:** If the machine does not pass either of the tests that follow, **Do not operate the machine.** Contact your authorized Toro distributor.



## Checking the Engine Starting Circuit

**Note:** The state of the parking brake interlock you are checking is shown in bold.

Engage the parking brake 	The starter rotates 
--	---

## Check Parking Brake Interlock

**Note:** The state of the parking brake interlock you are checking is shown in bold.

Disengage the parking brake 	The starter should not rotate 
---	--

## Jump Starting a Discharged Battery

The following instructions are adapted from the SAE J1494 Rev. Dec. 2001 – Battery Booster Cables – Surface Vehicle Recommended Practice (SAE – Society of Automotive Engineers).

## ⚠ DANGER

Jump starting a weak battery that is cracked, frozen, has low electrolyte level, or an open/shorted battery cell, can cause an explosion resulting in serious personal injury.

Do not jump start a weak battery if these conditions exist.

## ⚠ WARNING

Batteries contain acid and produce explosive gases.

- Always shield your eyes and face from the battery.
- Do not lean over the batteries.

## Preparing to Jump Start the Battery

### ⚠ CAUTION

Corrosion or loose connections can cause unwanted electrical voltage spikes at any time during the jump starting procedure.

Do Not attempt to jump start with loose or corroded battery terminals or damage to the engine may occur.

1. Check the cable clamps and battery terminals of the discharged battery for corrosion (white, green, or blue “snow”) and check that the hardware for the clamps is tight.

Clean corrosion from the battery terminals and cable clamps.

2. Check that the hardware for the cable clamps is tight.

Tighten the cable-clamp hardware as needed.

3. Check that the vent caps on the discharged battery and booster battery are tight and level.

4. If available, place damp clothes over the vent caps of both batteries.

5. If you are jump starting from the battery in another vehicle, ensure that it has a 12 V lead acid battery.

**Important:** Ensure that the 2 vehicles do not touch.

6. Ensure that the booster battery is fully charged with 12.6 V or greater.
7. Select properly sized jumper cables (4 to 6 AWG) with short lengths to reduce voltage drop between systems.

Choose jumper cables with color coded or polarity labeled cables or clamps.

## Connecting the Jumper Cables

### ⚠ CAUTION

Connecting the jumper cables incorrectly (wrong polarity) can immediately damage the electrical system.

Be certain of battery terminal polarity and jumper cable polarity when hooking up batteries.

1. Connect the positive jumper cable—red (+) to the positive-battery terminal of the discharged battery as shown in Figure 43.

**Note:** The positive-battery terminal is wired to the starter or solenoid

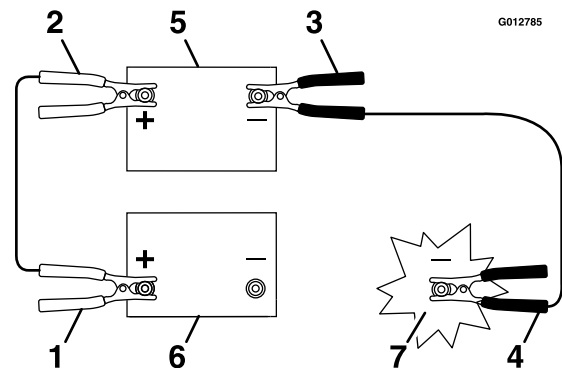

Figure 43

1. Positive (+) jumper cable at the discharged battery
2. Positive (+) jumper cable at the booster battery
3. Negative (-) jumper cable at the booster battery
4. Negative (-) jumper cable to the engine block (the machine with a discharged battery)
5. Booster battery
6. Discharged battery
7. Engine block (the machine with a discharged battery)

2. Connect the other end of the positive cable to the positive-battery terminal of the booster battery (Figure 43).
3. Connect the negative jumper cable—black (-) to the negative-battery terminal of the booster battery.
4. At the machine with a discharged battery, connect the other end of the negative jumper cable to the engine block, at a location away from the battery and belts (Figure 43).

## Starting the Engine and Removing the Jumper Cables

1. Start the engine.
2. Remove the negative cable from the engine block (Figure 43).
3. Remove the negative cable from the discharged battery (Figure 43).
4. Remove the positive cable from the booster battery (Figure 43)
5. Remove the positive cable from the discharged battery (Figure 43)

## Servicing the Battery

### ⚠ DANGER

Charging or jump-starting the battery may produce explosive gases. Battery gases can explode, causing serious injury.

- Keep sparks, flames, or cigarettes away from the battery.
- Ventilate when charging or using the battery in an enclosed space.
- Ensure that the venting path of the battery is always open once the battery is filled with acid.
- Always shield your eyes and face from the battery.

### ⚠ DANGER

Battery electrolyte contains sulfuric acid, which is fatal if consumed and can cause severe burns.

- Wear safety glasses to shield your eyes and rubber gloves to protect your skin and clothing when handling electrolyte.
- Do not swallow electrolyte.
- In the event of an accident, flush with water and call a doctor immediately.

### ⚠ CAUTION

If the key switch is in the ON position, there is potential for sparks and engagement of components. Sparks could cause an explosion or moving parts could accidentally engage, causing personal injury.

Ensure that the key switch is in the OFF position before charging the battery.

Allowing batteries to stand for an extended period of time without recharging them results in reduced performance and service life. To preserve optimum battery performance and life, charge batteries in storage when the open circuit voltage drops to 12.4 V.

**Note:** To prevent damage due to freezing, the battery should be fully charged before putting away for winter storage.

**Note:** The machine is shipped with a filled, lead-acid battery.

## Charging the Battery

**Service Interval:** Monthly

1. Move the key switch to the OFF position and remove the key.
2. Measure the voltage of the battery with a voltmeter.
3. Use the table below to locate the charge state or the battery, and if needed, the battery-charger setting and charging interval recommended to charge the battery to 12.6 V or greater; refer to the battery charge table below.

**Important:** Ensure that the negative battery cable is disconnected and the battery charger used for charging the battery has an output of 16 V and 7 A or less to avoid damaging the battery (see chart for recommended charger settings).

**Battery Charge Table**

Voltage Reading	Percent Charge	Maximum Charger Settings	Charging Interval
12.6 or greater	100%	16 V/ 7 A	No charging required
12.4 to 12.6	75 to 100%	16 V/ 7 A	30 minutes
12.2 to 12.4	50 to 75%	16 V/ 7 A	1 hour
12.0 to 12.2	25 to 50%	14.4 V/ 4 A	2 hours
11.7 to 12.0	0 to 25%	14.4 V/ 4 A	3 hours
11.7 or less	0%	14.4 V/ 2 A	6 hours or more

4. If the positive cable is also disconnected, connect the **positive (red) cable** to the positive battery terminal and slip the terminal cover over the positive terminal.

5. Remove the screw, washer, and ground cable from the engine. Connect the negative battery cable.

**Note:** If time does not permit charging the battery or if charging equipment is not available, connect the negative battery cables and run the vehicle continuously for 20 to 30 minutes to charge the battery.

## Drive System Maintenance

### Checking the Drive Tire Air Pressure

**Service Interval:** Every 50 hours

**Note:** You do not adjust air pressure for the semi-pneumatic caster tires.

1. Shut off the engine, engage the parking brake, remove the key, and wait for all moving parts to stop before leaving the operating position.
2. Check the air pressure of the drive tires.
3. Adjust the air pressure in the drive tires to 152 to 165 kPa (22 to 24 psi).

### Checking the Wheel Hub Bolts

**Service Interval:** Yearly

Torque the wheel hub bolts (Figure 44) to 37 to 45 N·m (27 to 33 ft-lb).

**Note:** Do not use anti-seize compound on the wheel hub.

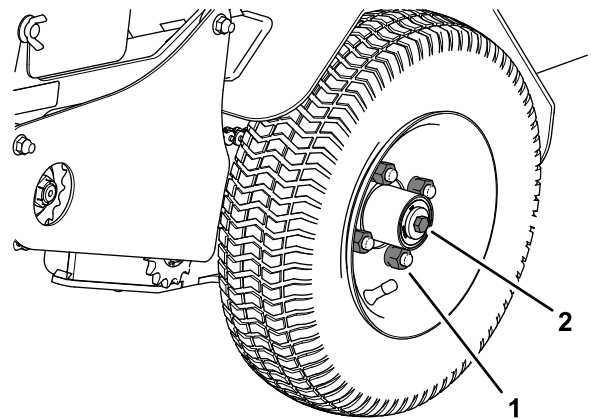

Figure 44

g249686

1. Lug nut

2. Hub bolt

### Checking the Torque of the Wheel Lug Nuts

**Service Interval:** Yearly

Torque the wheel lug nuts (Figure 44) to 115 to 142 N·m (85 to 105 ft-lb).

# Checking the Condition of the Chains

**Service Interval:** Before each use or daily

1. Shut off the engine, engage the parking brake, wait for all moving parts to stop, and remove the key.
2. Check the chains on both sides of the machine for proper tension. The chains should be able to move up and down 6 to 12 mm (1/4 to 1/2 inch).
3. If chains pop or snap refer to [Adjusting the Drive Wheel Chain Tension \(page 40\)](#) and [Adjusting the Tine Drive Chain \(page 49\)](#).

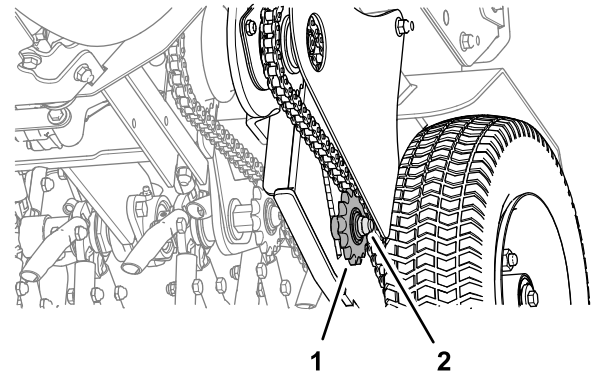

g268754

**Figure 45**

1. Idler sprocket
2. Idler bolt and locknut

# Checking the Sprocket Condition

**Service Interval:** Before each use or daily

1. Shut off the engine, engage the parking brake, wait for all moving parts to stop, and remove the key.
2. Inspect sprockets for wear and replace as required.

# Maintaining the Chain

## Adjusting the Drive Wheel Chain Tension

1. Shut off the engine, engage the parking brake, wait for all moving parts to stop, and remove the key.
2. Lift the rear of the machine and support using jack stands or equivalent support.
3. Check the chains on each side of the idler sprocket, at both sides of the machine, for proper tension.

The chains should move up and down 6 to 12 mm (1/4 to 1/2 inch).

4. To adjust the chain tension, loosen the idler bolt and locknut, and push up on the sprocket to tighten the chain ([Figure 45](#)).

**Important:** Do not overtighten the chain. Significant chain wear can occur and will shorten the life of an overtightened chain.

5. Check the chain tension and tighten the idler bolt and locknut.

# Checking the Torque of the Transmission Output Shaft Nut

**Service Interval:** After the first 5 hours

Yearly

Torque the nuts ([Figure 46](#)) on the transmission output tapered shafts to 285 to 353 N·m (210 to 260 ft·lb).

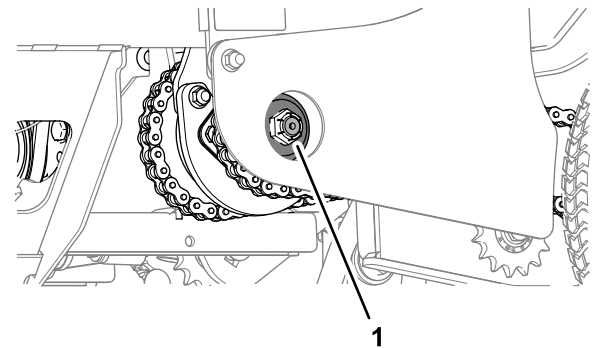

g268831

**Figure 46**

1. Nut (transmission-output shaft)



# Adjusting the Motion Control Linkage

1. Refer to [Preparing for Maintenance \(page 31\)](#).
2. Push the control levers all the way forward to the front reference bar; If either of the control levers contact the reference bar do the following:
  - A. Allow the control levers to return to neutral and loosen the 2 jam nuts on the hex adjustment linkage ([Figure 47](#)).

**Note:** One jam nut is a right-hand thread and the other is left-hand.

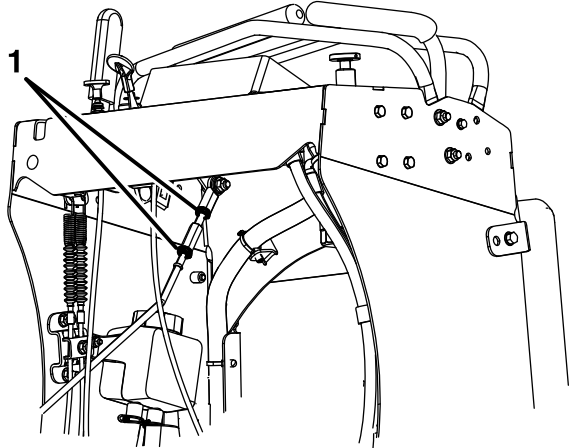

**Figure 47**

g231567

1. Hex adjustment linkage jam nut

- B. Turn the hex adjustment linkage until there is 3 to 6 mm (1/8 to 1/4 inch) gap between the control lever and the front reference bar.
  - C. Tighten the jam nuts ([Figure 47](#)).
3. Allow the control levers to return to neutral. Turn the left hex adjustment link until the motion control levers are approximately even with each other.
4. Repeat steps 2 and 3 for the other motion control linkage.

# Adjusting the Motion Control Tracking

If the machine travels or pulls to one side when the motion control levers are in the full forward position, adjust the tracking.

1. Push both control levers forward the same distance.
2. Check if the machine pulls to one side; If it does, stop the machine and set the parking brake.
3. Loosen the lock nuts on the right motion control linkage (as viewed from the rear of the machine). Push the right control lever forward and rotate the adjustment rod until there is 3 to 6 mm (1/8 to 1/4 inch) gap between the right control lever and the front reference bar.
4. Place the front reference/speed control bar in the maximum forward position; refer to [Adjusting the Front Reference/Speed Control Bar \(page 16\)](#).
5. Rotate the adjustment rod on the left side of the machine ([Figure 48](#)).

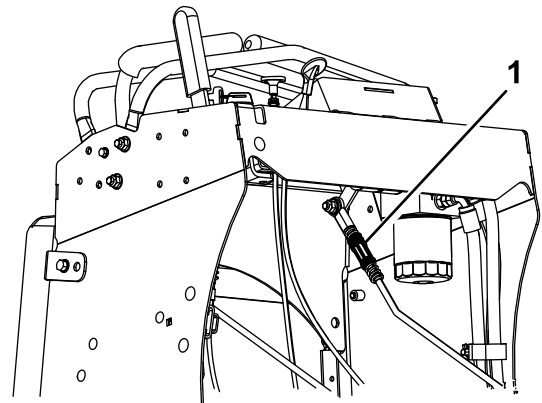

**Figure 48**

g233418

1. Adjustment rod
6. Looking down towards the adjustment rod — rotate it counterclockwise, in 1/4 turn increments, to increase speed or clockwise to decrease speed.
7. Drive the machine and check the full forward tracking.
8. Repeat steps 5 through 7 until desired tracking is obtained.

# Check Transmission Mount Bolt Torque

**Service Interval:** After the first 5 hours

Yearly thereafter

Torque the 4 transmission bolts to 56-69 N-m (41-51 ft-lb); refer to [Figure 49](#).

**Note:** Do Not use anti-seize compound on the wheel hub.

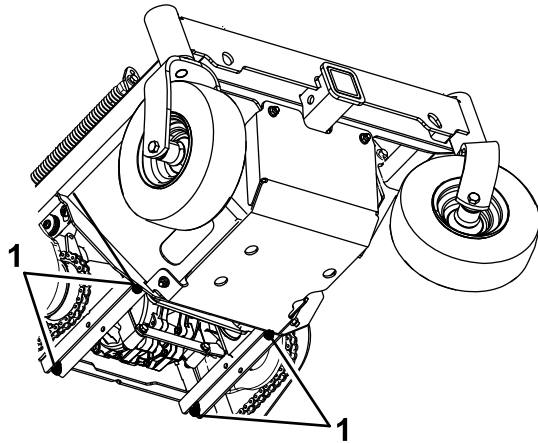

**Figure 49**

g233601

- 
1. Transmission bolts

# Brake Maintenance

## Adjusting the Parking Brake

If the parking brake does not hold securely, an adjustment is required.

1. Refer to [Preparing for Maintenance \(page 31\)](#).
2. Check the air pressure in the drive tires. If needed, adjust to the recommended inflation; refer to [Checking the Drive Tire Air Pressure \(page 39\)](#).
3. Disengage the parking brake.
4. Loosen the cable clamp on the brake cables under the console ([Figure 50](#)).
5. Adjust both cable conduits downward approximately 3 to 6 mm (1/8 to 1/4 inch).

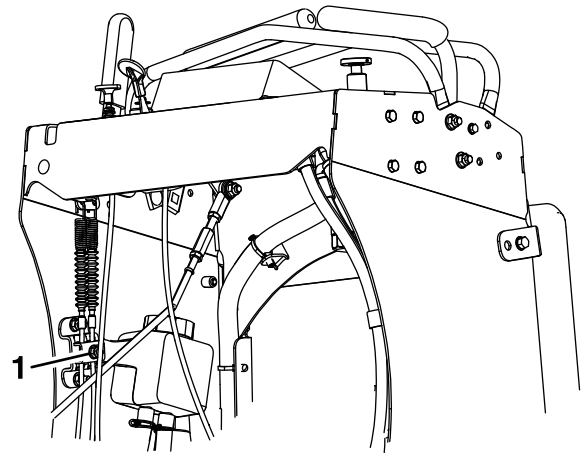

**Figure 50**

g233407

- 
1. Cable clamp

6. Tighten the cable clamp and engage the parking brake.
7. Check the parking brake; repeat steps [4](#) through [6](#) if necessary.

# Belt Maintenance

## Checking the Condition and Tension of the Belts

**Service Interval:** Every 50 hours

1. Shut off the engine, engage the parking brake, wait for all moving parts to stop, and remove the key.
2. Check the auxiliary pump drive belt condition and tension; the belt should be snug. Refer to [Adjusting the Auxiliary Pump Drive Belt \(page 43\)](#).
3. Check the condition of the transmission drive belt.

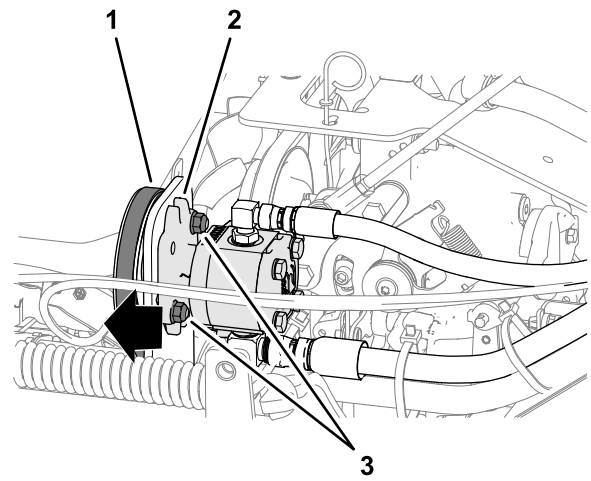

**Figure 52**

g266181

1. Auxiliary pump drive belt
2. Auxiliary pump
3. Flange locknuts

## Adjusting the Auxiliary Pump Drive Belt

1. Shut off the engine, engage the parking brake, wait for all moving parts to stop, and remove the key.
2. Remove the top thumbscrew, loosen the side thumbscrew, and remove the left hydraulic compartment cover ([Figure 51](#)).

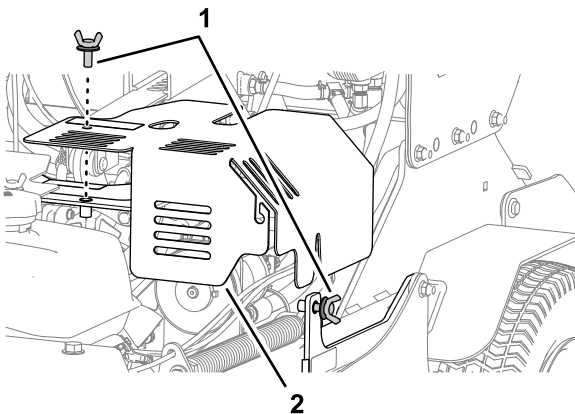

**Figure 51**

g266184

1. Thumbscrews
2. Hydraulic compartment cover (left)

4. Slide the pump outward ([Figure 52](#)) in slots and torque the flange locknuts to 37 to 45 N·m (27 to 33 ft lb).

When properly adjusted, the belt should have 1.3 cm (1/2 inch) of deflection with 3 pounds of force on the belt midway between the auxiliary pump and engine pulley.

5. Align the hole and slot in the left hydraulic compartment cover with the supports of the machine and secure the cover with the 2 thumbscrews ([Figure 51](#)).

## Checking the Transmission Drive Belt Tension

**Note:** No adjustments are required for belt tension.

1. Shut off the engine, engage the parking brake, wait for all moving parts to stop, and remove the key.
2. Install the new belt.
3. Ensure that the idler arm and pulley can move freely.

3. Loosen the 2 flange locknuts (3/8 inch) securing the auxiliary pump to the mounting bracket ([Figure 52](#)).

# Hydraulic System Maintenance

## Auxiliary Hydraulic Fluid Specification

Hydraulic fluid type: AW-32 hydro fluid

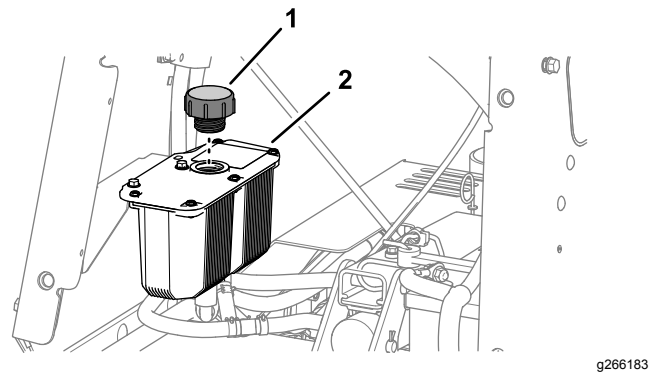

## Checking the Auxiliary Hydraulic Fluid Level

**Note:** The machine is shipped with hydraulic fluid in the reservoir.

1. Run the machine for approximately 15 minutes to purge any extra air out of the hydraulic system.
2. Completely raise and lower the tines 3 times to purge the air.
3. Shut off the engine, remove the key and allow the machine to cool.
4. Remove the cap and check the hydraulic-fluid level in the reservoir.

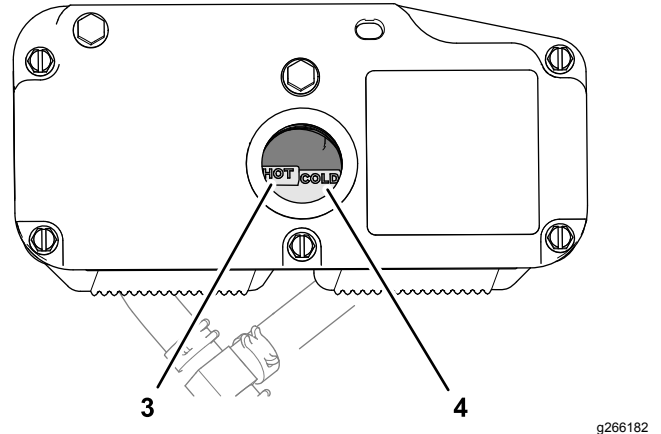

**Figure 53**

- |                                  |                              |
|----------------------------------|------------------------------|
| 1. Cap                           | 3. Hot fluid level (baffle)  |
| 2. Auxiliary hydraulic reservoir | 4. Cold fluid level (baffle) |

**Note:** The hydraulic-fluid level should cover the word FULL COLD that is embossed into the baffle of the reservoir (Figure 53).

5. If necessary, add the specified hydraulic fluid to the reservoir until the fluid covers the FULL COLD fluid level on the baffle (Figure 53).

**Note:** If the fluid is at ambient-air temperature, about 24°C (75° F), fill only to the FULL COLD level.

6. Install the hydraulic reservoir cap (Figure 53) and tighten it until snug.

**Note:** Do not overtighten the reservoir cap.

## Changing the Auxiliary Hydraulic Reservoir Fluid and Filter

### Draining the Auxiliary Hydraulic Fluid

1. Run the machine for approximately 15 minutes to purge any extra air out of the hydraulic system.
2. Completely raise and lower the tines 3 times to purge the air.

3. Shut off the engine, engage the parking brake, wait for all moving parts to stop, and remove the key.
4. Allow the engine to cool.
5. Carefully clean the area around the front of the auxiliary pump and fill cap; also clean around the filter. It is important that no dirt or contamination enter hydraulic system.
6. Loosen the suction hose at the pump fitting, clean around the pump fitting, and allow oil to drain (Figure 54).

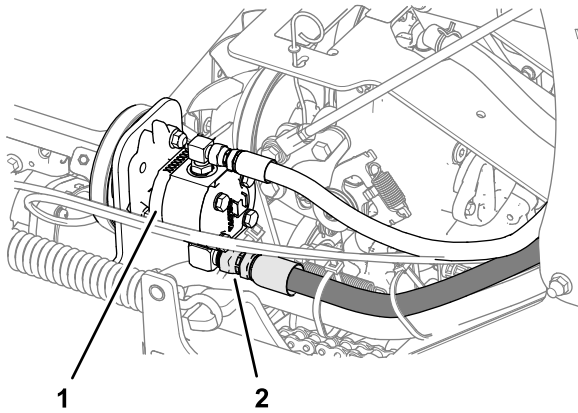

**Figure 54**

1. Auxiliary pump
2. Suction hose

g268753

7. Install the suction hose and torque to 50 N-m (37 ft-lb).

## Changing the Filter

**Service Interval:** After the first 100 hours  
Every 250 hours thereafter

1. Unscrew the filter to remove it and allow oil to drain (Figure 55).

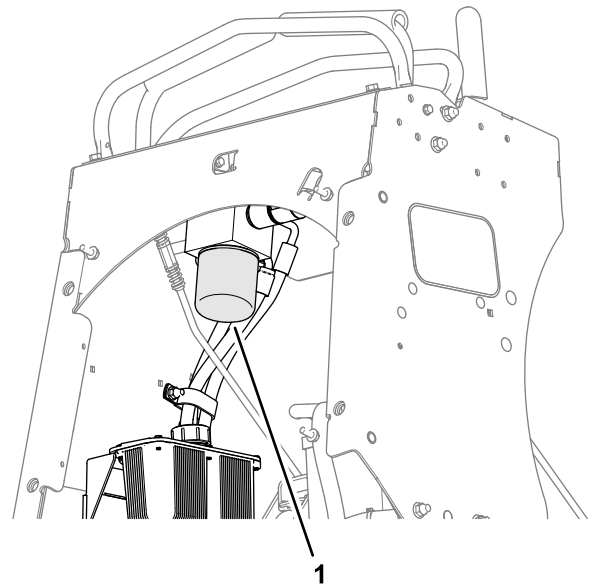

**Figure 55**

g268752

1. Filter (auxiliary-hydraulic system)
- 
2. Apply a thin coat of the specified hydraulic fluid to the rubber seal of the new filter; refer to [Auxiliary Hydraulic Fluid Specification \(page 44\)](#).
  3. Turn the filter clockwise until rubber seal contacts the filter adapter, then tighten the filter an additional 2/3 to 3/4 turn (Figure 55).

## Adding Auxiliary Hydraulic Fluid

1. Remove the cap and check the hydraulic-fluid level in the reservoir.
2. Add the specified hydraulic fluid until the level reaches the FULL COLD line located on the reservoir tank; refer to [Auxiliary Hydraulic Fluid Specification \(page 44\)](#) and [Checking the Auxiliary Hydraulic Fluid Level \(page 44\)](#).

**Note:** If the fluid is at ambient-air temperature, about 24°C (75° F), fill only to the FULL COLD level.

3. Install the hydraulic reservoir cap and tighten it until snug.

**Note:** Do not overtighten the reservoir cap.

4. Start the engine and raise and lower the tines. Lower the tines to the ground and refill the reservoir to the FULL COLD line.
5. Check the fluid level again; repeat steps 2 through 5 until the level does not decrease.

# Transmission Fluid Specification

**Transmission fluid type:** Toro® Hypr-Oil™ 500 or Mobil® 1 15W-50 synthetic motor oil.

**Important:** Use the specified fluid. Other fluids could cause system damage.

## Checking the Transmission Fluid Level

**Service Interval:** Every 50 hours

1. Shut off the engine, engage the parking brake, remove the key, and wait for all moving parts to stop before leaving the operating position.
2. Allow the machine to cool.
3. Remove the cap from the expansion tank and check the transmission-fluid level in the tank (Figure 56).

**Note:** The transmission fluid level should cover the FULL COLD fill line molded into the side of the tank.

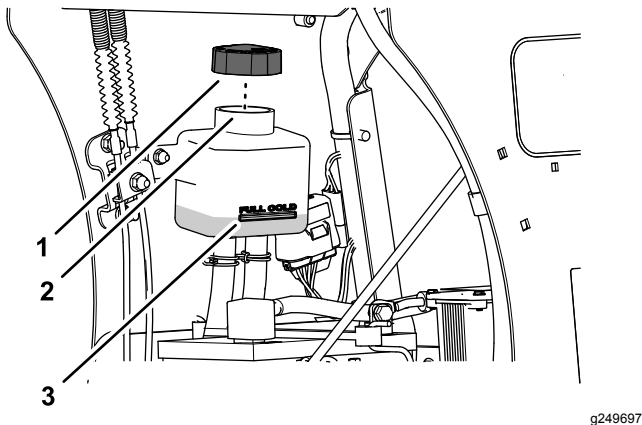

Figure 56

1. Cap
2. Filler neck (expansion tank)
3. FULL COLD line

4. If necessary, add the specified transmission fluid until the fluid level is at the FULL COLD fill line of the expansion tank (Figure 56).
5. Install the expansion tank cap and tighten it until snug.

**Important:** Do not overtighten the expansion tank cap.

# Changing the Hydraulic Transmission Filters and Fluid

**Service Interval:** After the first 100 hours  
Every 250 hours thereafter

**Important:** Do not change the hydraulic fluid (except for what can be drained when changing filter and removing the drain plugs), unless it is felt the oil has been contaminated or been extremely hot.

Changing the oil unnecessarily could damage hydraulic system by introducing contaminants into the system.

## Draining the Auxiliary Hydraulic Fluid

1. Shut off the engine, engage the parking brake, wait for all moving parts to stop, and remove the key.
2. Place a drain pan between the transmissions.
3. Remove the 2 drain plugs, located at the bottom of each transmission, and allow the fluid to drain.
4. Locate the 2 filters under the transmissions (Figure 57).

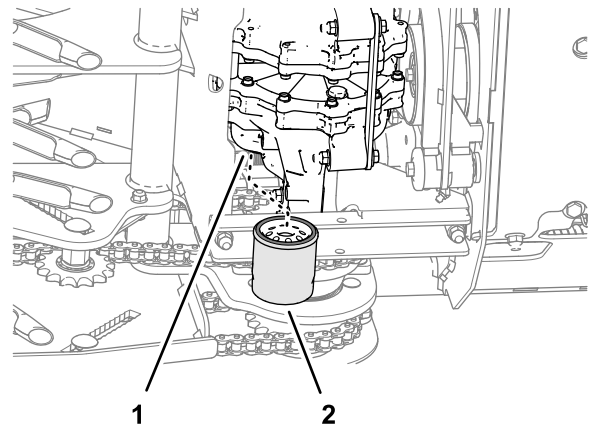

Figure 57

1. Transmission
2. Filter (transmission)

5. Carefully clean area around filters.

**Important:** Do not allow dirt or contamination enters the hydraulic system.

6. Remove the filters to and allow the fluid to drain from the drive system (Figure 57).
7. Install the 2 drain plugs.

## Installing the Transmission Filters

1. Apply a thin coat of the specified hydraulic fluid to the rubber seal of the new filters; refer to [Transmission Fluid Specification \(page 46\)](#).
2. Turn the filter clockwise until rubber seal contacts the filter adapter, then tighten the filter an additional 2/3 to 3/4 turn ([Figure 57](#)).
3. Remove the vent plug at each transmission.

## Adding Transmission Fluid

1. Remove cap from the expansion tank, add the specified transmission fluid to the tank until fluid comes out of the transmission vent, and install the plug; refer to [Transmission Fluid Specification \(page 46\)](#) and [Checking the Transmission Fluid Level \(page 46\)](#).
2. Repeat step 1 until fluid comes out of the vent of the other transmission, and install the plug.
3. Torque the vent plugs to 20 N·m (180 in-lb).
4. Continue to adding the specified transmission fluid until it reaches the FULL COLD line on the expansion reservoir; refer to [Figure 56](#) in [Checking the Transmission Fluid Level \(page 46\)](#).
5. Raise the rear of machine up and support with jack stands (or equivalent support) just high enough to allow the drive wheels to turn freely.

### ⚠ CAUTION

**Raising the machine for service or maintenance relying solely on mechanical or hydraulic jacks could be dangerous. The mechanical or hydraulic jacks may not be enough support or may malfunction allowing the machine to fall, which could cause injury.**

**Do not rely solely on mechanical or hydraulic jacks for support. Use adequate jack stands or equivalent support.**

6. Start the engine and move the throttle control ahead to 1/2 throttle position. Disengage the parking brake.

### ⚠ WARNING

**The engine must be running and the drive wheels must be turning so motion control adjustment can be performed. Contact with moving parts or hot surfaces may cause personal injury.**

**Keep your fingers, hands, and clothing clear of rotating components and hot surfaces.**

7. With the engine running, slowly move the directional control in both forward and reverse directions (5 to 6 times). Check the oil level, and add oil as required after shutting off the engine.  
It may be necessary to repeat step 7 until all air is purged from the system. Air is purged from the transaxle when it operates at normal sound levels and moves forward and reverse smoothly at normal speeds.
8. Shut off the engine, remove the key, engage the parking brake, and wait for all moving part to stop.
9. Remove the jack stands and lower the rear of machine.
10. Reset the transmission-oil maintenance reminder; refer to [Resetting the Transmission-Oil Maintenance Reminder \(page 47\)](#).

## Resetting the Transmission-Oil Maintenance Reminder

1. Prepare the machine for maintenance; refer to [Preparing for Maintenance \(page 31\)](#).
2. Cycle the key switch between the RUN position and the OFF position 6 times within 8 seconds.

The Service Transmission screen displays and flashes ([Figure 58](#)).

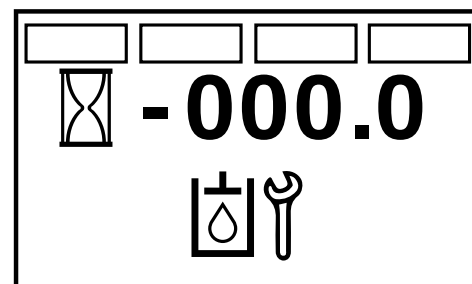

**Figure 58**

Service Transmission Screen

g212118

3. Press down the multi-function switch.

The transmission-oil maintenance reminder resets to 250 (hours), exits the service transmission screen, and returns to the default screen.

**Note:** You can exit the service transmission screen at any time by turning the key to either the OFF or the START positions.

# Tine Maintenance

## Checking the Tines

**Service Interval:** Before each use or daily

1. Shut off the engine, engage the parking brake, remove the key, and wait for all moving parts to stop before leaving the operating position.
2. Raise the machine and support it with jack stands with a 460 kg (1,015 lb) capacity.

### ⚠ CAUTION

Raising the machine for service or maintenance relying solely on mechanical or hydraulic jacks could be dangerous. The mechanical or hydraulic jacks may not be enough support or may malfunction allowing the machine to fall, which could cause injury.

**Do not rely solely on mechanical or hydraulic jacks for support. Use adequate jack stands or equivalent support.**

3. Remove the 2 thumbscrews (3/8 x 1 inch) and 2 washers (3/8 inch) that secure the rear-cover panel to the chassis, and remove the panel (Figure 59).

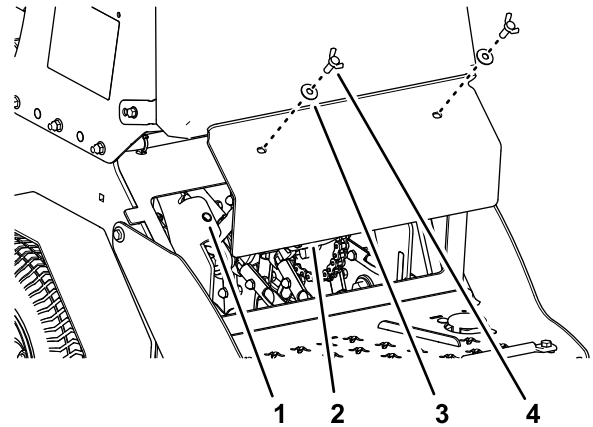

Figure 59

g249698

- |                 |                              |
|-----------------|------------------------------|
| 1. Chassis hole | 3. Washer (3/8 inch)         |
| 2. Rear panel   | 4. Thumbscrew (3/8 x 1 inch) |

4. Remove rocks and other debris from the tines.
5. Inspect the tines for wear and damage.

**Note:** Replace any tines that are worn or damaged.

6. Align the holes in the rear-cover panel to the holes in the chassis (Figure 59).



- Secure the cover panel to the chassis with the 2 thumbscrews and 2 washers (Figure 59) that you removed in step 3, and torque the bolts to 37 to 45 N·m (27 to 33 in-lb)

## Adjusting the Tine Drive Chain

- Shut off the engine, engage the parking brake, wait for all moving parts to stop, and remove the key.

- Lift the rear of the machine and support using jack stands or equivalent support.

- Check the chains on each side of the idler sprocket, at both sides of the machine, for proper tension.)

The chains should move up and down 6 to 12 mm (1/4 to 1/2 inch).

- To adjust the chain tension, loosen the idler bolt and threaded spacer, and push up on the sprocket to tighten the chain (Figure 60).

**Important:** Do not overtighten the chain. Significant chain wear can occur and will shorten the life of an overtightened chain.

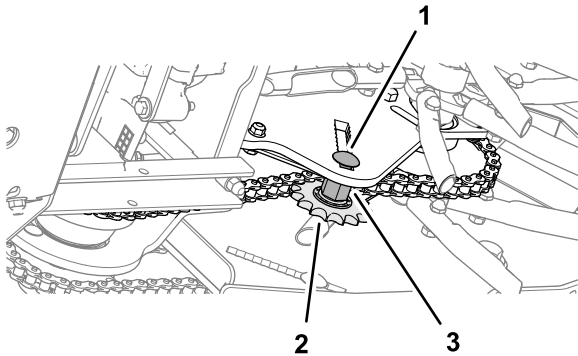

Figure 60

g268810

- |                   |                    |
|-------------------|--------------------|
| 1. Idler bolt     | 3. Threaded spacer |
| 2. Idler sprocket |                    |

- Check the chain tension and tighten the idler bolt.

## Adjusting the Return-to-Up Spring

### ⚠ WARNING

Springs have stored energy. Overtightening the springs may cause the springs to fail which can cause serious injury or death and damage to the machine and property.

**Make sure springs are properly adjusted and/or replaced as specified in the Operator's manual.**

Check the gap between the spring bracket and the end of the spring as shown in Figure 61. The gap should measure 35 mm (1.38 inch). The adjustment is made by turning the bolt at the front of each spring (clockwise will shorten the gap, counter-clockwise will lengthen the gap).

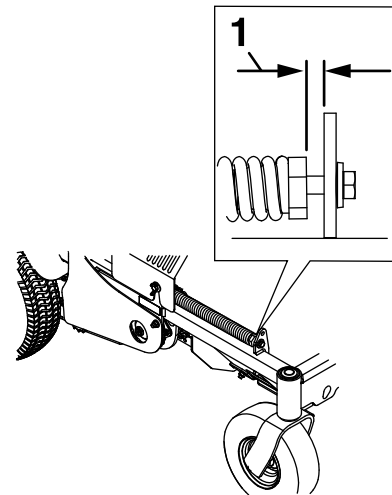

Figure 61

g233568

- 35 mm (1.38 inch)

**Important:** The springs must be replaced if the gap is less than 29 mm (1.13 inches).

**Always replace both return-to-up springs. This prevents uneven loading and possible damage to the machine.**

# Chassis Maintenance

## Check for Loose Hardware

**Service Interval:** Before each use or daily

1. Stop engine, wait for all moving parts to stop, and remove key. Engage parking brake.
2. Visually inspect machine for any loose hardware or any other possible problem. Tighten hardware or correct the problem before operating.

# Cleaning

## Washing the Machine

Wash the machine as needed using water alone or with a mild detergent. You may use a rag when washing the machine.

**Important:** Do not use brackish or reclaimed water to clean the machine.

**Important:** Do not use power-washing equipment to wash the machine. Power-washing equipment may damage the electrical system, loosen important decals, or wash away necessary grease at friction points. Avoid excessive use of water near the control panel, engine, and battery.

**Important:** Do not wash the machine with the engine running. Washing the machine with the engine running may result in internal engine damage.

## Cleaning the Engine and the Exhaust System Area

**Service Interval:** Before each use or daily (more often in dry or dirty conditions).

### **⚠ CAUTION**

Excessive debris around engine cooling air intake and exhaust system area can cause engine, exhaust area, and hydraulic system to overheat, which can create a fire hazard.

**Clean all debris from engine and exhaust system area.**

1. Shut off the engine, engage the parking brake, remove the key, and wait for all moving parts to stop before leaving the operating position.
2. Clean all debris from screen at the top of the engine, around engine shrouding, and exhaust system area.
3. Wipe up any excessive grease or oil around the engine and exhaust system area.

## Removing the Engine Shrouds and Cleaning the Cooling Fins

**Service Interval:** Every 80 hours

1. Shut off the engine, engage the parking brake, remove the key, and wait for all moving parts to stop before leaving the operating position.

2. Remove cooling shrouds from engine.
3. Clean cooling fins of the engine.

**Note:** Also clean dust, dirt, and oil from external surfaces of engine, which can cause improper cooling.

4. Install the cooling shrouds into the engine.

**Important:** Operating the engine without cooling shrouds causes engine damage due to overheating. Do not operate the machine without the cooling shrouds.

for batteries must follow relevant federal, state, or local laws.

If a battery is being replaced or if the machine containing the battery is no longer operating and is being scrapped, remove the battery and take it to a local certified recycling center. If no local recycling is available return the battery to any certified battery reseller.

## Cleaning the Debris from the Machine

**Service Interval:** Before each use or daily

1. Shut off the engine, engage the parking brake, remove the key, and wait for all moving parts to stop before leaving the operating position.
2. Clean off any oil, debris, or grass buildup on the machine and aerator deck.
3. Clean off any debris or grass under the chain guards, around the fuel tank, and around the engine and exhaust area.

## Disposing of Waste

### Disposing of Waste Oil

Engine oil and hydraulic fluid are both pollutants to the environment. Dispose of used oil at a certified recycling center or according to your state and local regulations.

### Disposing of the Battery

#### **⚠ DANGER**

**Battery electrolyte contains sulfuric acid, which is poisonous and can cause severe burns. Swallowing electrolyte can be fatal or if it touches skin can cause severe burns.**

- **Wear safety glasses to shield eyes, and rubber gloves to protect skin and clothing when handling electrolyte.**
- **Do not swallow electrolyte.**
- **In the event of an accident, flush with water and call a doctor immediately.**

Federal law states that batteries should not be placed in the garbage. Management and disposal practices

# Storage

1. Raise the tines, stop the machine, shut off the engine, engage the parking brake, and remove the key. Place the key out of reach from children
2. Remove dirt and grime from the entire machine.

***Important:*** You can wash the machine with mild detergent and water. Do not pressure-wash the machine. Avoid excessive use of water, especially near the engine and hydrostatic drive.

3. Service the air cleaner; refer to [Servicing the Air Cleaner \(page 32\)](#).
4. Lubricate the machine; refer to [Lubrication \(page 31\)](#).
5. Change the engine oil; refer to [Changing the Engine Oil \(page 34\)](#).
6. Check and tighten all bolts, nuts, and screws. Repair or replace any part that is damaged.
7. Paint all scratched or bare metal surfaces. Paint is available from your authorized Toro distributor.
8. Store the machine in a clean, dry garage or storage area.
9. Cover the machine to protect it and keep it clean.

# Troubleshooting

## Alert and Error Messages

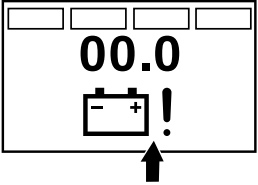
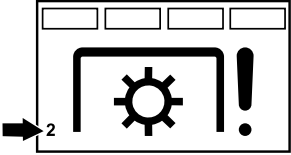
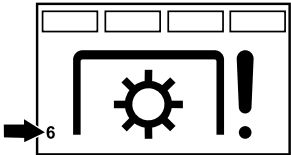
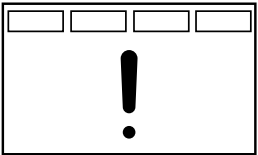
Message	Icon	Description	Resolution
Voltage Error		The ignition key is in the RUN position and the smart controller/electronic depth control measures that the electrical system is less than 12.3V or greater than 16V.  The voltage error icon displays, and the LED status light flashes a red.	Check the battery, charging system, and wiring.
Valve Solenoid Overcurrent Error		An over-current event occurs at the solenoid valve.  The valve solenoid over-current error displays with the number 2 and the LED status light flashes a red.	Check the valve solenoid and inspect it for damage and wear.
Valve Solenoid Open Error		1 of the 2 valve solenoids or both valve solenoids are disconnected.  The valve solenoid open error displays with the number 6 and the LED status light flashes a red.	Connect the valve solenoid(s).
Valve Solenoid Connection Error		The valve solenoids are connected wrong (the connector for the relief valve is connected to the other valve solenoid).  The valve solenoid connection error alert displays, and the tines will not operate until the fault is corrected.	Swap the valve solenoid connectors.

Problem	Possible Cause	Corrective Action
The starter does not crank.	<ol style="list-style-type: none"> <li>1. The parking brake is not engaged.</li> <li>2. The battery does not have a full charge.</li> <li>3. The electrical connections are corroded, loose or faulty.</li> <li>4. A fuse is blown.</li> <li>5. A relay or switch is not functioning properly.</li> </ol>	<ol style="list-style-type: none"> <li>1. Engage the parking brake.</li> <li>2. Charge the battery.</li> <li>3. Check the electrical connections for good contact. Clean the connector terminals thoroughly with electrical contact cleaner, apply dielectric grease, and reconnect.</li> <li>4. Replace the blown fuse.</li> <li>5. Contact an Authorized Service Dealer.</li> </ol>

Problem	Possible Cause	Corrective Action
The engine does not start, starts hard, or fails to keep running.	<ol style="list-style-type: none"> <li>1. The fuel tank is empty.</li> <li>2. The fuel-shutoff valve is closed.</li> <li>3. The throttle and choke are not in the correct position.</li> <li>4. There is dirt, water, or stale fuel in the fuel system.</li> <li>5. The air cleaner is dirty.</li> <li>6. The electrical connections are corroded, loose or faulty.</li> <li>7. A relay or switch is not functioning properly.</li> <li>8. The spark plug is faulty.</li> <li>9. The spark-plug wire is not connected.</li> <li>10. The ambient temperature is too low.</li> </ol>	<ol style="list-style-type: none"> <li>1. Fill the fuel tank.</li> <li>2. Open the fuel-shutoff valve.</li> <li>3. Ensure that the throttle level is midway between the SLOW and FAST positions, and the choke is in the ON position for a cold engine or the OFF position for a warm engine.</li> <li>4. Contact an Authorized Service Dealer.</li> <li>5. Clean or replace the air-cleaner element.</li> <li>6. Check the electrical connections for good contact. Clean connector terminals thoroughly with electrical contact cleaner, apply dielectric grease, and connect.</li> <li>7. Contact an Authorized Service Dealer.</li> <li>8. Clean, adjust, or replace the spark plug.</li> <li>9. Check the spark-plug wire connection.</li> <li>10. Place the machine into a warmer environment and allow the hydraulic fluid and engine oil to warm sufficiently.</li> </ol>
The engine loses power.	<ol style="list-style-type: none"> <li>1. The engine load is excessive.</li> <li>2. The air cleaner is dirty.</li> <li>3. The oil level in the crankcase is low.</li> <li>4. The cooling fins and air passages for the engine are plugged.</li> <li>5. There is dirt, water, or stale fuel in the fuel system.</li> </ol>	<ol style="list-style-type: none"> <li>1. Reduce the ground speed or aeration depth.</li> <li>2. Clean or replace the air-cleaner element.</li> <li>3. Add oil to the crankcase.</li> <li>4. Remove the obstructions from the cooling fins and air passages.</li> <li>5. Contact an Authorized Service Dealer.</li> </ol>
The engine overheats.	<ol style="list-style-type: none"> <li>1. The engine load is excessive.</li> <li>2. The oil level in the crankcase is low.</li> <li>3. The cooling fins and air passages for the engine are plugged.</li> </ol>	<ol style="list-style-type: none"> <li>1. Reduce the ground speed or aeration depth.</li> <li>2. Add oil to the crankcase.</li> <li>3. Remove the obstructions from the cooling fins and air passages.</li> </ol>
The machine pulls left or right (with levers fully forward).	<ol style="list-style-type: none"> <li>1. The tire pressure in drive tires is not correct.</li> <li>2. The tracking needs adjustment.</li> </ol>	<ol style="list-style-type: none"> <li>1. Adjust the tire pressure in the drive tires.</li> <li>2. Adjust the traction-control linkage.</li> </ol>
The machine does not drive.	<ol style="list-style-type: none"> <li>1. The transmission belt worn, loose, or broken.</li> <li>2. The transmission belt is off a pulley.</li> </ol>	<ol style="list-style-type: none"> <li>1. Change the belt.</li> <li>2. Change the belt.</li> </ol>
There is abnormal vibration.	<ol style="list-style-type: none"> <li>1. A tine is bent.</li> <li>2. The tine mounting bolt is loose.</li> <li>3. The engine mounting bolts are loose.</li> <li>4. There is a loose engine pulley or idler pulley.</li> <li>5. The engine pulley is damaged.</li> <li>6. A belt is damaged.</li> <li>7. The chains are not properly tensioned.</li> </ol>	<ol style="list-style-type: none"> <li>1. Install a new tine.</li> <li>2. Tighten the tine mounting bolt.</li> <li>3. Tighten the engine mounting bolts.</li> <li>4. Tighten the appropriate pulley.</li> <li>5. Contact an Authorized Service Dealer.</li> <li>6. Install a new belt.</li> <li>7. Check the drive wheel chain tension and the tine drive-chain tension.</li> </ol>

Problem	Possible Cause	Corrective Action
The tines do not raise.	<ol style="list-style-type: none"> <li>1. There is a short in the wire harness.</li> <li>2. The return-to-up springs are not properly adjusted.</li> <li>3. The return-to-up springs are damaged.</li> </ol>	<ol style="list-style-type: none"> <li>1. Contact an Authorized Service Dealer.</li> <li>2. Adjust the return-to-up springs.</li> <li>3. Replace the return-to-up springs.</li> </ol>
The tines do not engage the ground.	<ol style="list-style-type: none"> <li>1. The tine down pressure setting is too low.</li> <li>2. Electronic depth control is set too shallow.</li> <li>3. The harness/switch is damaged.</li> <li>4. The auxiliary reservoir is low on oil.</li> </ol>	<ol style="list-style-type: none"> <li>1. Increase the tine down pressure.</li> <li>2. Increase the electrical depth control setting.</li> <li>3. Contact an Authorized Service Dealer.</li> <li>4. Add oil to the reservoir.</li> </ol>

# Schematics

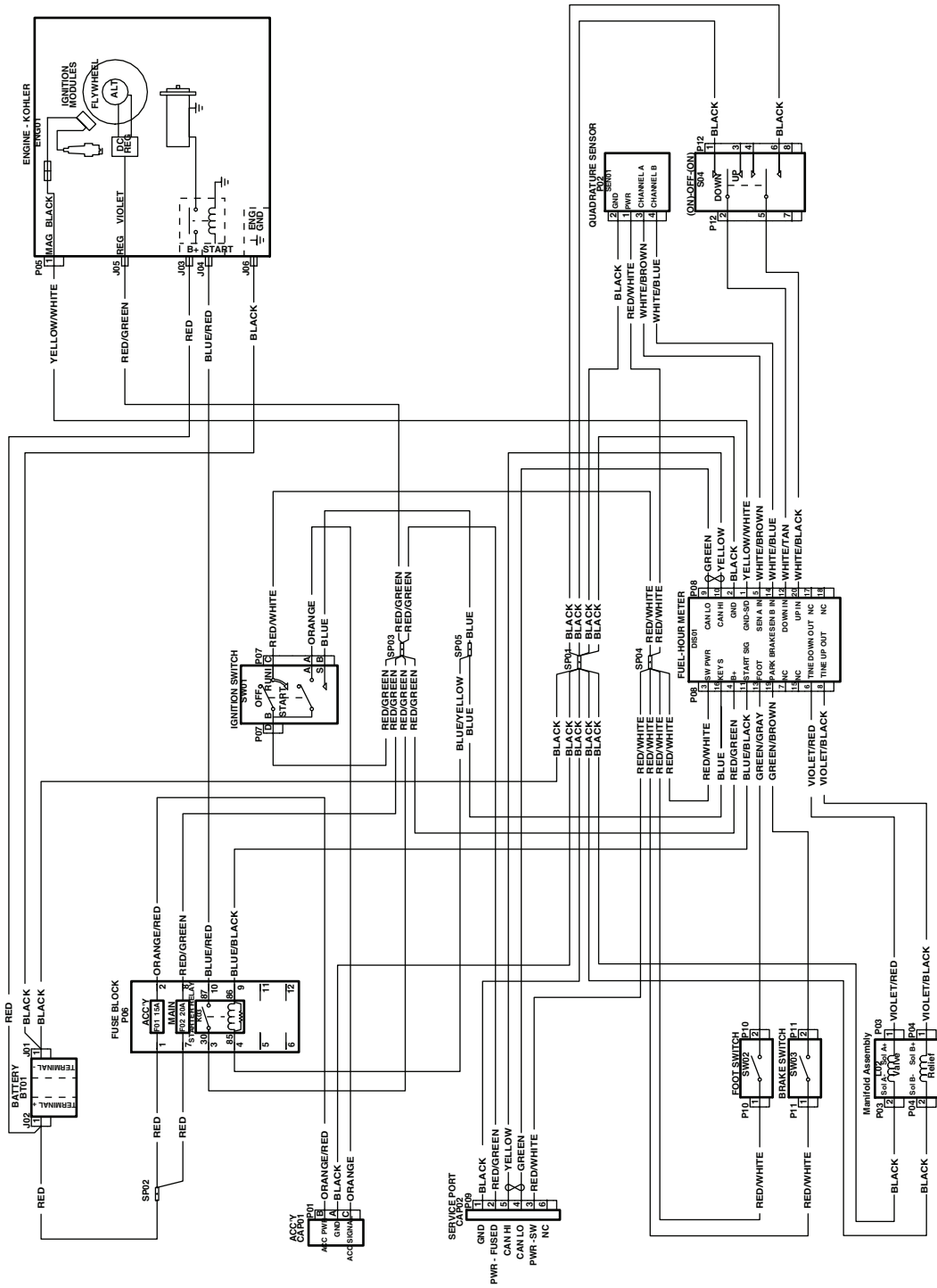

Electrical Schematic (Rev. 126-5344 rev A)

g231578





**Notes:**

# California Proposition 65 Warning Information

## What is this warning?

You may see a product for sale that has a warning label like the following:



**WARNING: Cancer and Reproductive Harm—[www.p65Warnings.ca.gov](http://www.p65Warnings.ca.gov).**

## What is Prop 65?

Prop 65 applies to any company operating in California, selling products in California, or manufacturing products that may be sold in or brought into California. It mandates that the Governor of California maintain and publish a list of chemicals known to cause cancer, birth defects, and/or other reproductive harm. The list, which is updated annually, includes hundreds of chemicals found in many everyday items. The purpose of Prop 65 is to inform the public about exposure to these chemicals.

Prop 65 does not ban the sale of products containing these chemicals but instead requires warnings on any product, product packaging, or literature with the product. Moreover, a Prop 65 warning does not mean that a product is in violation of any product safety standards or requirements. In fact, the California government has clarified that a Prop 65 warning "is not the same as a regulatory decision that a product is 'safe' or 'unsafe.'" Many of these chemicals have been used in everyday products for years without documented harm. For more information, go to <https://oag.ca.gov/prop65/faqs-view-all>.

A Prop 65 warning means that a company has either (1) evaluated the exposure and has concluded that it exceeds the "no significant risk level"; or (2) has chosen to provide a warning based on its understanding about the presence of a listed chemical without attempting to evaluate the exposure.

## Does this law apply everywhere?

Prop 65 warnings are required under California law only. These warnings are seen throughout California in a wide range of settings, including but not limited to restaurants, grocery stores, hotels, schools, and hospitals, and on a wide variety of products. Additionally, some online and mail order retailers provide Prop 65 warnings on their websites or in catalogs.

## How do the California warnings compare to federal limits?

Prop 65 standards are often more stringent than federal and international standards. There are various substances that require a Prop 65 warning at levels that are far lower than federal action limits. For example, the Prop 65 standard for warnings for lead is 0.5 µg/day, which is well below the federal and international standards.

## Why don't all similar products carry the warning?

- Products sold in California require Prop 65 labelling while similar products sold elsewhere do not.
- A company involved in a Prop 65 lawsuit reaching a settlement may be required to use Prop 65 warnings for its products, but other companies making similar products may have no such requirement.
- The enforcement of Prop 65 is inconsistent.
- Companies may elect not to provide warnings because they conclude that they are not required to do so under Prop 65; a lack of warnings for a product does not mean that the product is free of listed chemicals at similar levels.

## Why does Toro include this warning?

Toro has chosen to provide consumers with as much information as possible so that they can make informed decisions about the products they buy and use. Toro provides warnings in certain cases based on its knowledge of the presence of one or more listed chemicals without evaluating the level of exposure, as not all the listed chemicals provide exposure limit requirements. While the exposure from Toro products may be negligible or well within the "no significant risk" range, out of an abundance of caution, Toro has elected to provide the Prop 65 warnings. Moreover, if Toro does not provide these warnings, it could be sued by the State of California or by private parties seeking to enforce Prop 65 and subject to substantial penalties.



**Count on it.**