



**Count on it.**

**Operator's Manual**

**GrandStand<sup>®</sup> Mower**

**With 91cm Rear Discharge TURBO FORCE<sup>®</sup>  
Cutting Unit**

Model No. 74540TE—Serial No. 40000000 and Up

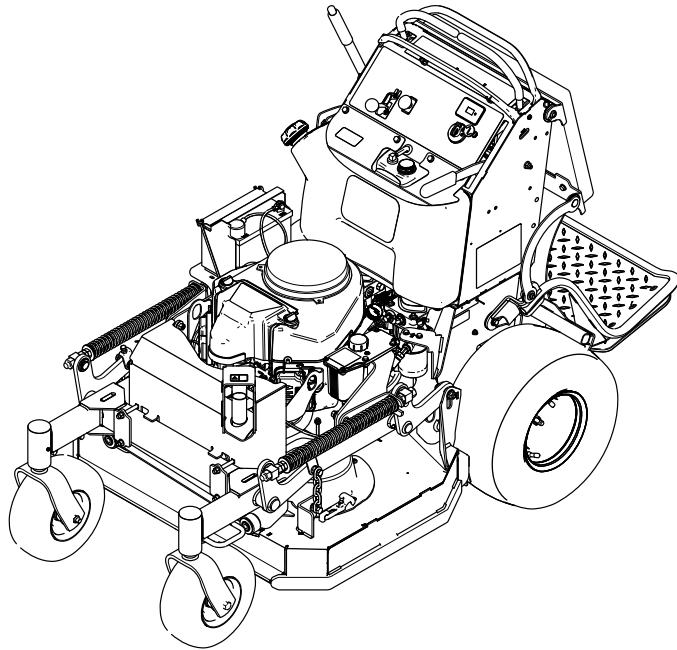

This product complies with all relevant European directives; for details, please see the separate product specific Declaration of Conformity (DOC) sheet.

Please refer to the engine manufacturer's information included with the machine.

# Introduction

This rotary-blade, stand-on lawn mower is intended to be used by professional, hired operators. It is designed primarily for cutting grass on well-maintained lawns on residential or commercial properties. Using this product for purposes other than its intended use could prove dangerous to you and bystanders.

Read this information carefully to learn how to operate and maintain your product properly and to avoid injury and product damage. You are responsible for operating the product properly and safely.

Visit [www.Toro.com](http://www.Toro.com) for more information, including safety tips, training materials, accessory information, help finding a dealer, or to register your product.

Whenever you need service, genuine Toro parts, or additional information, contact an Authorized Service Dealer or Toro Customer Service and have the model and serial numbers of your product ready. [Figure 1](#) identifies the location of the model and serial numbers on the product. Write the numbers in the space provided.

**Important:** With your mobile device, you can scan the QR code on the serial number decal (if equipped) to access warranty, parts, and other product information.

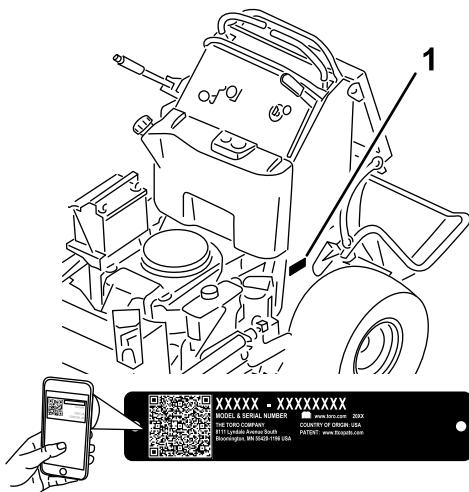

Figure 1

g276640

1. Location of the model and serial numbers

Model No. _____
Serial No. _____

This manual identifies potential hazards and has safety messages identified by the safety-alert symbol ([Figure 2](#)), which signals a hazard that may cause serious injury or death if you do not follow the recommended precautions.



Figure 2

g000502

1. Safety-alert symbol

This manual uses 2 words to highlight information. **Important** calls attention to special mechanical information and **Note** emphasizes general information worthy of special attention.

# Contents

Safety .....	4	Drive System Maintenance .....	37
General Safety .....	4	Adjusting the Tracking .....	37
Safety and Instructional Decals .....	4	Adjusting the Proximity Switch .....	37
Product Overview .....	8	Checking the Tire Pressure .....	38
Controls .....	8	Adjusting the Caster-Pivot Bearing .....	39
Specifications .....	9	Adjusting the Electric Clutch .....	39
Attachments/Accessories .....	9	Cooling System Maintenance .....	40
Before Operation .....	10	Cleaning the Air-Intake Screen .....	40
Before Operation Safety .....	10	Cleaning the Cooling System .....	40
Adding Fuel .....	10	Brake Maintenance .....	41
Performing Daily Maintenance .....	11	Testing the Parking Brake .....	41
Breaking in a New Machine .....	11	Checking the Brake Clearance .....	41
Using the Safety-Interlock System .....	11	Adjusting the Brakes .....	42
During Operation .....	12	Belt Maintenance .....	42
During Operation Safety .....	12	Checking the Belts .....	42
Operating the Parking Brake .....	13	Replacing the Mower-Deck Belt .....	42
Operating the PTO .....	14	Replacing the Pump-Drive Belt .....	43
Operating the Throttle .....	14	Controls System Maintenance .....	44
Operating the Choke .....	14	Adjusting the Right Motion-Control	
Operating the Ignition Switch .....	15	Lever .....	44
Starting the Engine .....	15	Adjusting the Neutral Position for the	
Shutting Off the Engine .....	16	Motion-Control Levers .....	45
Operating the Platform .....	16	Hydraulic System Maintenance .....	46
Driving Forward or Backward .....	17	Hydraulic System Safety .....	46
Adjusting the Height of Cut .....	18	Hydraulic System Specifications .....	46
Using Weights .....	18	Checking the Hydraulic Fluid .....	46
After Operation .....	19	Replacing the Hydraulic Fluid .....	47
After Operation Safety .....	19	Replacing the Hydraulic Filter .....	48
Using the Fuel-Shutoff Valve .....	19	Bleeding the Hydraulic System .....	49
Pushing the Machine by Hand .....	20	Checking the Hydraulic Hoses .....	49
Transporting the Machine .....	20	Mower Deck Maintenance .....	49
Maintenance .....	22	Servicing the Cutting Blades .....	49
Maintenance Safety .....	22	Leveling the Mower Deck .....	51
Recommended Maintenance Schedule(s) .....	23	Cleaning .....	55
Pre-Maintenance Procedures .....	24	Cleaning under the Mower Deck .....	55
Raising the Mower for Access .....	24	Cleaning the Rear Wheel Motors .....	55
Releasing the Cushion for Rear Access .....	25	Disposing of Waste .....	55
Removing the Belt Covers .....	26	Storage .....	56
Removing the Deck Guards .....	26	Storage Safety .....	56
Lubrication .....	27	Cleaning and Storage .....	56
Greasing the Machine .....	27	Troubleshooting .....	57
Greasing the Front Caster Pivots .....	27	Schematics .....	59
Greasing the Caster-Wheel Hubs .....	28		
Engine Maintenance .....	29		
Engine Safety .....	29		
Servicing the Air Cleaner .....	29		
Servicing the Engine Oil .....	30		
Servicing the Spark Plug .....	32		
Checking the Spark Arrester .....	33		
Fuel System Maintenance .....	33		
Draining the Fuel Tank .....	33		
Replacing the Fuel Filter .....	34		
Electrical System Maintenance .....	34		
Electrical System Safety .....	34		
Servicing the Battery .....	34		
Servicing the Fuses .....	36		

# Safety

This machine has been designed in consideration with EN ISO 5395.

## General Safety

This product is capable of amputating hands and feet and of throwing objects. Always follow all safety instructions to avoid serious personal injury.

- Read and understand the contents of this *Operator's Manual* before starting the engine.
- Do not put your hands or feet near moving components of the machine.
- Do not operate the machine without all guards and other safety protective devices in place and functioning properly on the machine.

- Keep clear of the discharge opening.
- Keep bystanders and children out of the operating area. Do not allow children to operate the machine. Allow only people who are responsible, trained, familiar with the instructions, and physically capable to operate the machine.
- Stop the machine, shut off the engine, and remove the ignition key before servicing, fueling, or unclogging the machine.

Improperly using or maintaining this machine can result in injury. To reduce the potential for injury, comply with these safety instructions and always pay attention to the safety-alert symbol **▲**, which means Caution, Warning, or Danger—personal safety instruction. Failure to comply with these instructions may result in personal injury or death.

## Safety and Instructional Decals



Safety decals and instructions are easily visible to the operator and are located near any area of potential danger. Replace any decal that is damaged or missing.



### Battery Symbols

Some or all of these symbols are on your battery.

- |  |  |
|--|--|
| 1. Explosion hazard                    | 6. Keep bystanders away.   |
| 2. No fire, open flames, or smoking    | 7. Wear eye protection—explosive gases can cause blindness and other injuries. |
| 3. Caustic liquid/chemical burn hazard | 8. Battery acid can cause severe burns.  |
| 4. Wear eye protection.                | 9. Flush eyes immediately with water and get medical help fast.                |
| 5. Read the <i>Operator's Manual</i> . | 10. Contains lead; do not discard.   |



### Manufacturer's Mark

1. Indicates the blade is identified as a part from the original machine manufacturer.

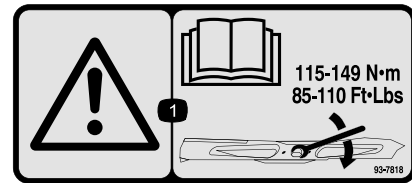

93-7818

1. Warning—read the *Operator's Manual* for instructions on torquing the blade bolt/nut to 115 to 149 N·m (85 to 110 ft-lb).



106-5517

1. Warning—do not touch the hot surface.

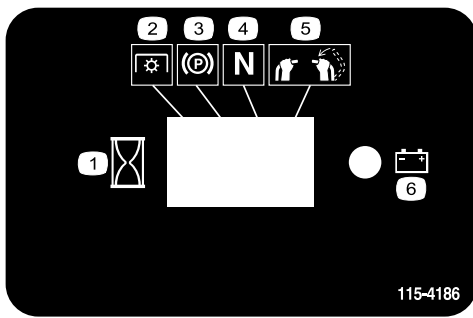

115-4186

decal115-4186

1. Interval
2. PTO
3. Parking brake
4. Neutral
5. Operator presence switch
6. Battery

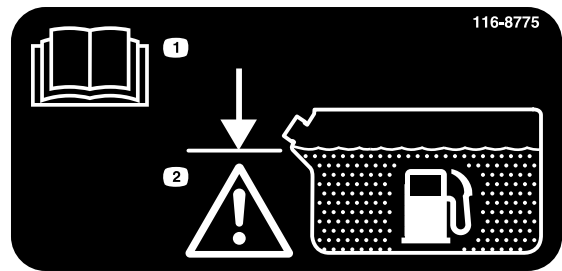

116-8775

decal116-8775

1. Read the *Operator's Manual*.
2. Warning—fill to the bottom of the filler neck; do not overfill the tank.



115-4212

decal115-4212

1. Hydraulic fluid level
2. Read the *Operator's Manual*.
3. Warning—do not touch the hot surface.

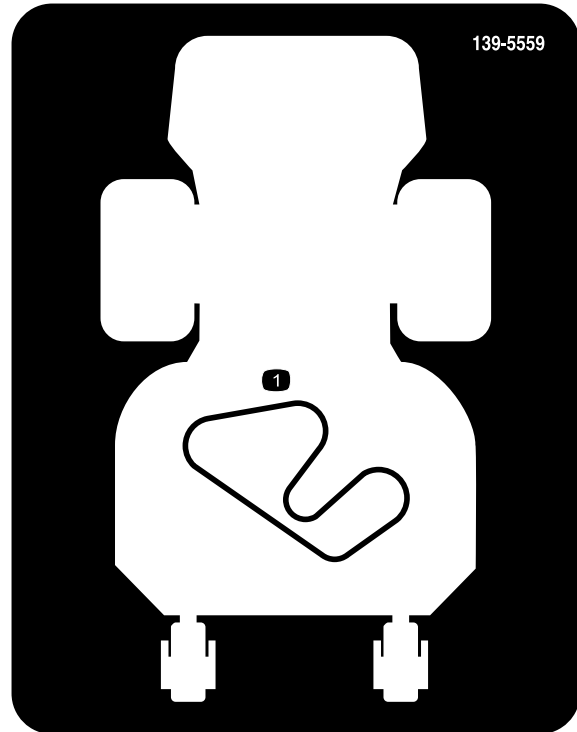

139-5559

decal139-5559

1. Belt routing

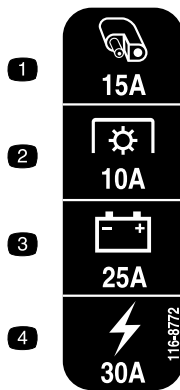

116-8772

decal116-8772

1. Accessory, 15A
2. PTO, 10A
3. Charge, 25A
4. Main, 30A

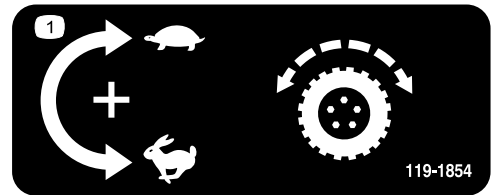

119-1854

decal119-1854

1. Adjustment knob for traction drive speed.

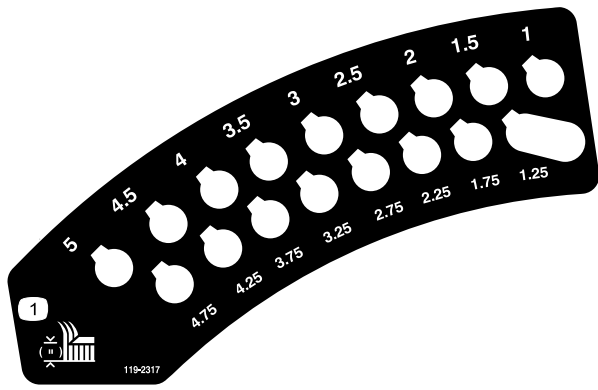

119-2317

decal119-2317

1. Height of cut

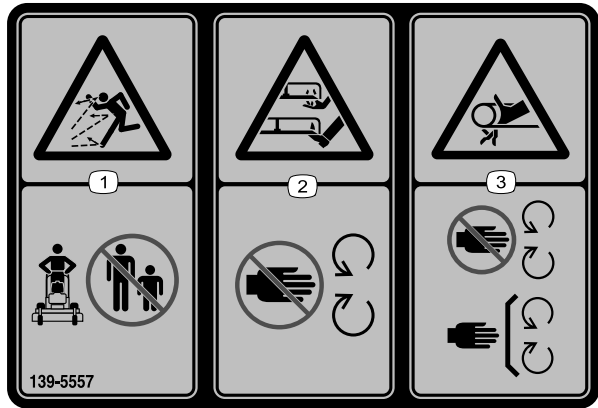

139-5557

decal139-5557

1. Thrown object hazard—keep bystanders away.
2. Cutting/dismemberment hazard of hand or foot, mower blade—stay away from moving parts.
3. Entanglement hazard, belt—stay away from moving parts; keep all guards and shields in place.

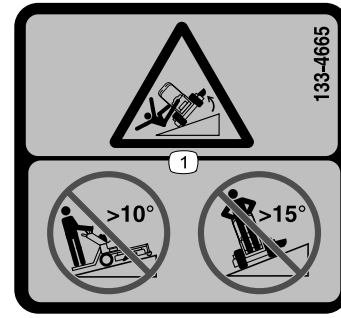

133-4665

decal133-4665

1. Tipping hazard—do not operate up slopes greater than 10°; do not operate across slopes greater than 15°.

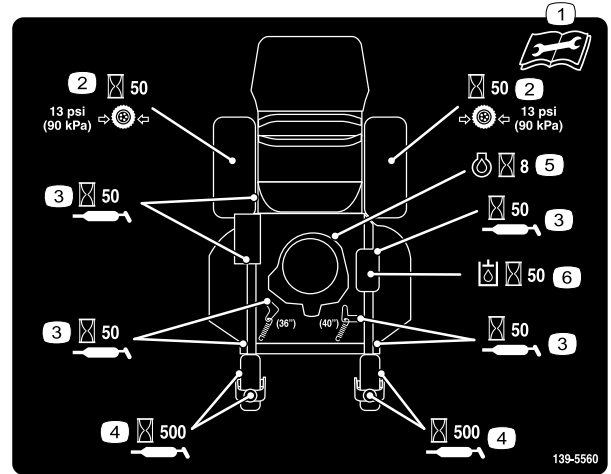

139-5560

decal139-5560

1. Read the *Operator's Manual* before performing maintenance.
2. Check the drive wheel tire pressure every 50 hours.
3. Lubricate every 50 hours.
4. Lubricate the caster wheel every 500 hours.
5. Check the engine oil every 8 hours.
6. Check the hydraulic fluid every 50 hours.

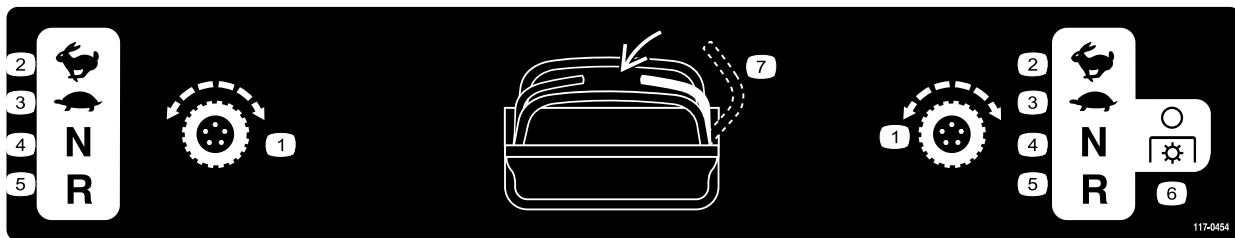

117-0454

decal117-0454

1. Traction control
2. Fast
3. Slow
4. Neutral
5. Reverse
6. PTO—disengage
7. Operator presence switch

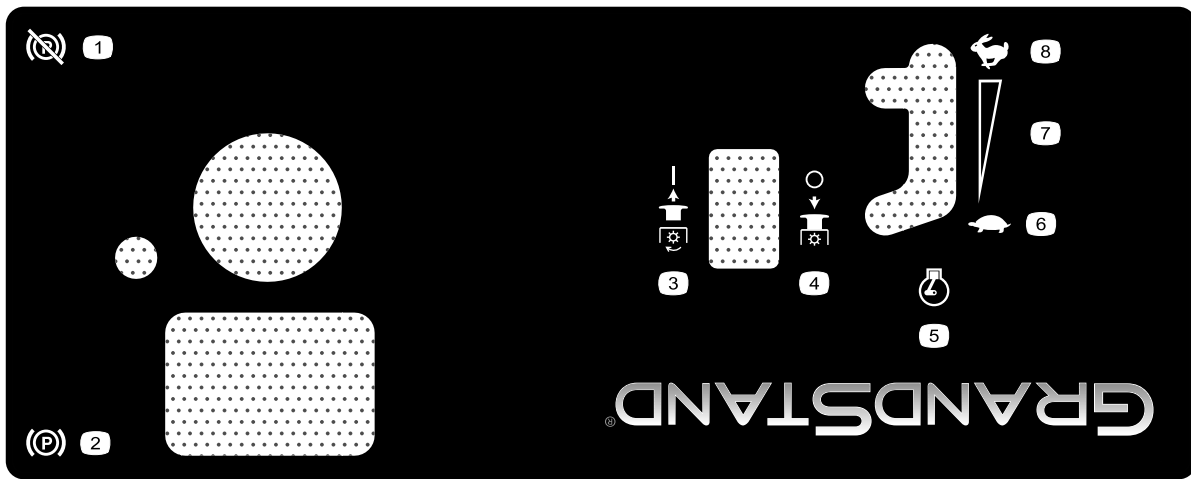

decal125-4679

**125-4679**

- |                             |                                |
|-----------------------------|--------------------------------|
| 1. Parking brake—disengaged | 5. Engine speed                |
| 2. Parking brake—engaged    | 6. Slow                        |
| 3. PTO—engaged              | 7. Continuous variable setting |
| 4. PTO—disengaged           | 8. Fast                        |

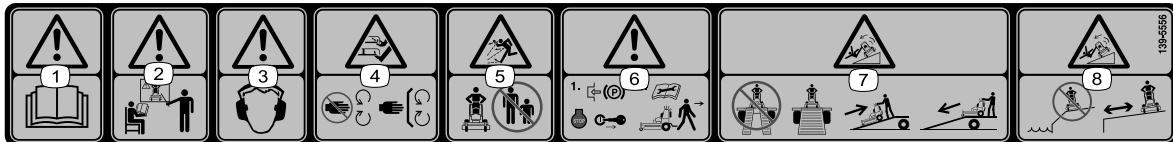

decal139-5556

**139-5556**

- |   |   |
|---|---|
| 1. Warning—read the <i>Operator's Manual</i> .  | 5. Thrown object hazard—keep bystanders away.   |
| 2. Warning—do not operate the machine unless you are trained.   | 6. Warning—engage the parking brake, shut off the engine, and remove the key before leaving the machine or performing maintenance.  |
| 3. Warning—wear hearing protection.   | 7. Tipping hazard—when loading onto a trailer, do not use dual ramps; only use a singular ramp wide enough for the machine; back up the ramp (in reverse) and drive forward off the ramp. |
| 4. Cutting/dismemberment hazard of hand or foot, mower blade—stay away from moving parts; keep all guards and shields in place. | 8. Tipping hazard—do not operate the machine near drop-offs or water; stay away from drop-offs.   |

# Product Overview

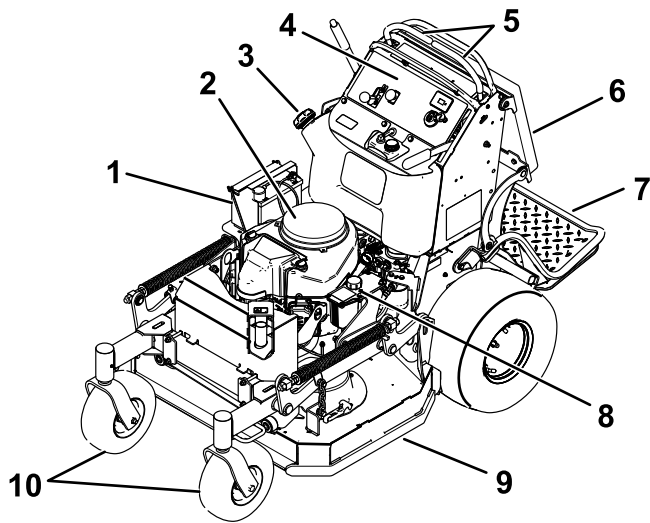

**Figure 3**

g277381

- |                          |                             |
|--------------------------|-----------------------------|
| 1. Battery               | 6. Operator cushion         |
| 2. Engine                | 7. Platform (down position) |
| 3. Fuel tank             | 8. Hydraulic tank           |
| 4. Control panel         | 9. Mower deck               |
| 5. Motion-control levers | 10. Front caster wheels     |

# Controls

Become familiar with all the controls before you start the engine and operate the machine.

## Control Panel

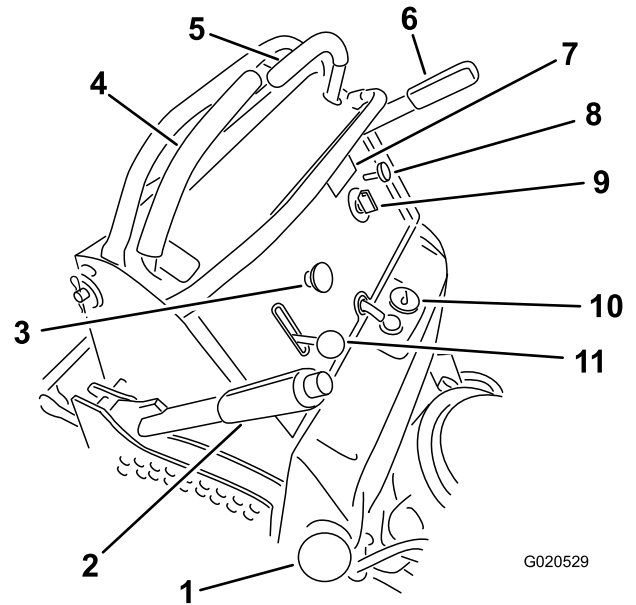

**Figure 4**

G020529

g020529

- |                               |                      |
|-------------------------------|----------------------|
| 1. Fuel cap                   | 7. Hour meter        |
| 2. Height-of-cut lever        | 8. Choke control     |
| 3. Power-Takeoff switch (PTO) | 9. Key switch        |
| 4. Right motion-control lever | 10. Fuel gauge       |
| 5. Left motion-control lever  | 11. Throttle control |
| 6. Parking-brake lever        |                      |

## Hour Meter

The hour meter records the number of hours the engine has operated. It operates when the engine is running. Use these times for scheduling regular maintenance ([Figure 5](#)).

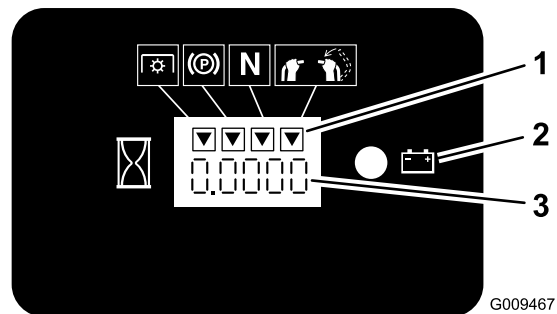

G009467

g009467

**Figure 5**

- |                             |               |
|-----------------------------|---------------|
| 1. Safety-interlock symbols | 3. Hour meter |
| 2. Battery light            |               |



## Fuel Gauge

The fuel gauge is located on the top, middle of the tank ([Figure 4](#)).

## Safety-Interlock Indicators

Symbols on the hour meter indicate with a black triangle that the interlock component is in the correct position ([Figure 5](#)).

## Battery-Indicator Light

If you turn the key to the ON position for a few seconds, the battery voltage displays in the area where the hours are normally displayed.

The battery light turns on when you turn the key to the ON position and when the charge is below the correct operating level ([Figure 5](#)).

## Throttle Control

The throttle controls the engine speed, and it has a continuous-variable setting from the SLOW to FAST position ([Figure 4](#)).

## Choke Control

Use the choke control to start a cold engine. Pull the choke control up to engage it. Push down on the choke control to disengage it.

## Power-Takeoff Switch (PTO)

Use the power-takeoff switch (PTO) to engage and disengage the mower blades ([Figure 4](#)); refer to [Operating the PTO \(page 14\)](#).

## Key Switch

The key switch, used to start and shut off the engine, has 3 positions: OFF, RUN, and START. Refer to [Operating the Ignition Switch \(page 15\)](#).

## Motion-Control Levers

Use the motion-control levers to drive the machine forward, reverse, and turn either direction ([Figure 4](#)).

## Fuel-Shutoff Valve

Close the fuel-shutoff valve when transporting or storing the machine; refer to [Using the Fuel-Shutoff Valve \(page 19\)](#).

## Specifications

**Note:** Specifications and design are subject to change without notice.

Cutting width	91 cm (36 inches)
Width	97 cm (38 inches)
Length with platform down	188 cm (74 inches)
Length with platform up	155 cm (61 inches)
Height	122 cm (48 inches)
Weight	352 kg (776 lb)

## Attachments/Accessories

A selection of Toro approved attachments and accessories is available for use with the machine to enhance and expand its capabilities. Contact your Authorized Service Dealer or authorized Toro distributor or go to [www.Toro.com](http://www.Toro.com) for a list of all approved attachments and accessories.

To ensure optimum performance and continued safety certification of the machine, use only genuine Toro replacement parts and accessories. Replacement parts and accessories made by other manufacturers could be dangerous, and such use could void the product warranty.

# Operation

## Before Operation

### Before Operation Safety

#### General Safety

- Never allow children or untrained people to operate the machine. Local regulations may restrict the age of the operator. The owner is responsible for training all operators and mechanics.
  - Become familiar with the safe operation of the equipment, operator controls, and safety signs.
  - Know how to stop the machine and shut off the engine quickly.
  - Check that operator-presence controls, safety switches, and guards are attached and functioning properly. Do not operate the machine unless they are functioning properly.
  - Before mowing, always inspect the machine to ensure that the blades, blade bolts, and cutting assemblies are in good working condition.
  - Inspect the area where you will use the machine and remove all objects that the machine could throw.
  - Evaluate the terrain to determine the appropriate equipment and any attachments or accessories required to operate the machine properly and safely.
- Store fuel in an approved container and keep it out of the reach of children.
  - Fuel is harmful or fatal if swallowed. Long-term exposure to vapors can cause serious injury and illness.
    - Avoid prolonged breathing of vapors.
    - Keep your hands and face away from the nozzle and the fuel-tank opening.
    - Keep fuel away from your eyes and skin.
  - Do not store the machine or fuel container where there is an open flame, spark, or pilot light, such as on a water heater or on other appliances.
  - Do not fill containers inside a vehicle or on a truck or trailer bed with a plastic liner. Always place containers on the ground, away from your vehicle before filling.
  - Remove the equipment from the truck or trailer and refuel it while it is on the ground. If this is not possible, then refuel from a portable container rather than a fuel-dispenser nozzle.
  - Do not operate the machine without the entire exhaust system in place and in proper working condition.
  - Keep the fuel-dispenser nozzle in contact with the rim of the fuel tank or container opening at all times until fueling is complete. Do not use a nozzle lock-open device.
  - If you spill fuel on your clothing, change your clothing immediately. Wipe up any fuel that spills.
  - Never overfill the fuel tank. Replace the fuel cap and tighten it securely.

#### Fuel Safety

- Fuel is extremely flammable and highly explosive. A fire or explosion from fuel can burn you and others and can damage property.
  - To prevent a static charge from igniting the fuel, place the container and/or machine directly on the ground before filling, not in a vehicle or on an object.
  - Fill the fuel tank outdoors, in an open area, when the engine is cold. Wipe up any fuel that spills.
  - Do not handle fuel when smoking or around an open flame or sparks.
  - Do not remove the fuel cap or add fuel to the tank while the engine is running or hot.
  - If you spill fuel, do not attempt to start the engine. Avoid creating a source of ignition until the fuel vapors have dissipated.

## Adding Fuel

### Recommended Fuel

- For best results, use only clean, fresh (less than 30 days old), unleaded gasoline with an octane rating of 87 or higher ((R+M)/2 rating method).
- **Ethanol:** Gasoline with up to 10% ethanol (gasohol) or 15% MTBE (methyl tertiary butyl ether) by volume is acceptable. Ethanol and MTBE are not the same. Gasoline with 15% ethanol (E15) by volume is not approved for use. **Never use gasoline that contains more than 10% ethanol by volume**, such as E15 (contains 15% ethanol), E20 (contains 20% ethanol), or E85 (contains up to 85% ethanol). Using unapproved gasoline may cause performance problems and/or engine damage which may not be covered under warranty.

- **Do not** use gasoline containing methanol.
- **Do not** store fuel either in the fuel tank or fuel containers over the winter unless you use a fuel stabilizer.
- **Do not** add oil to gasoline.

## Using Stabilizer/Conditioner

Use fuel stabilizer/conditioner in the machine to keep the fuel fresh longer when used as directed by the fuel-stabilizer manufacturer.

**Important:** Do not use fuel additives containing methanol or ethanol.

Add the amount of fuel stabilizer/conditioner to fresh fuel as directed by the fuel-stabilizer manufacturer.

## Filling the Fuel Tank

1. Park the machine on a level surface, disengage the PTO, move the motion-control levers to the NEUTRAL-LOCK position, and engage the parking brake.
2. Shut off the engine, remove the key, and wait for all moving parts to stop before leaving the operating position.
3. Clean around the fuel-tank cap and remove the cap.
4. Fill the fuel tank to the bottom of the filler neck.

**Note:** Do not fill the fuel tank completely full. The empty space in the tank allows the gasoline to expand.

5. Install the fuel-tank cap securely. Wipe up any spilled fuel.

## Performing Daily Maintenance

Before starting the machine each day, perform the Each Use/Daily procedures listed in [Maintenance \(page 22\)](#).

## Breaking in a New Machine

New engines take time to develop full power. Mower decks and drive systems have higher friction when new, placing additional load on the engine. Allow 40 to 50 hours of break-in time for new machines to develop full power and best performance.

## Using the Safety-Interlock System

### ⚠ WARNING

If safety-interlock switches are disconnected or damaged, the machine could operate unexpectedly, causing personal injury.

- Do not tamper with the interlock switches.
- Check the operation of the interlock switches daily, and replace any damaged switches before operating the machine.

## Understanding the Safety-Interlock System

The safety-interlock system is designed to prevent PTO from engaging unless you do 1 of the following:

- Move the right motion-control lever to the center, unlocked position.
- Pull the PTO switch to the ON position.

The safety-interlock system is designed to stop the blades/attachment if you move or release both motion-control levers into the NEUTRAL-LOCK position.

The hour meter has symbols to notify the user when each interlock component is in the correct position. When the component is in the correct position, a triangle lights up in the corresponding square ([Figure 6](#)).

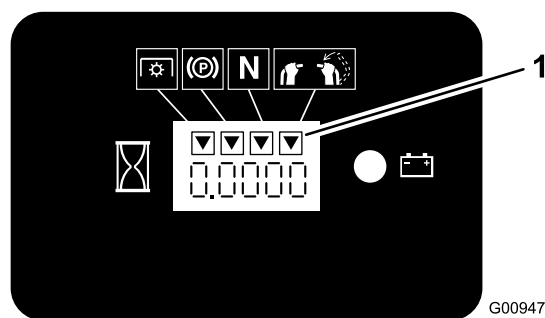

**Figure 6**

1. The triangles light up when the interlock components are in the correct position.

# Testing the Safety-Interlock System

**Service Interval:** Before each use or daily

Test the safety-interlock system before you use the machine each time.

**Note:** If the safety system does not operate as described below, have an Authorized Service Dealer repair the safety system immediately.

1. Start the engine; refer to [Starting the Engine \(page 15\)](#).
2. Move the right motion-control lever to the center, unlocked position.  
**Note:** The blades/attachment should stop and the engine should stop running.
3. Start the engine and disengage the parking brake.
4. Move the right motion-control lever to the center, unlocked position.
5. Continue holding the motion-control lever in the center, unlocked position, pull up on the PTO switch, and release the switch.  
**Note:** The clutch and blades/attachment should engage.
6. Move or release the right motion-control lever into the NEUTRAL-LOCK position.  
**Note:** The blades/attachment should stop and the engine should continue to run.
7. Push the PTO switch down and move the right motion-control lever to the center, unlocked position.
8. Continue holding the motion-control lever in the center, unlocked position, pull up on the PTO switch, and release the switch.  
**Note:** The clutch and blades/attachment should engage.
9. Push the PTO switch down to the OFF position.  
**Note:** The blades/attachment should stop.
10. With the engine running, pull up the PTO switch and release it without holding the right motion-control lever to the center, unlocked position.  
**Note:** The blades/attachment should not engage.

# During Operation

## During Operation Safety

### General Safety

- The owner/operator can prevent and is responsible for accidents that may cause personal injury or property damage.
- Wear appropriate clothing, including eye protection; long pants; substantial, slip-resistant footwear; and hearing protection. Tie back long hair and do not wear loose clothing or loose jewelry.
- Use your full attention while operating the machine. Do not engage in any activity that causes distractions; otherwise, injury or property damage may occur.
- Do not operate the machine while ill, tired, or under the influence of alcohol or drugs.
- Never carry passengers on the machine and keep bystanders and pets away from the machine during operation.
- Operate the machine only in good visibility and appropriate weather conditions. Do not operate the machine when there is the risk of lightning.
- Wet grass or leaves can cause serious injury if you slip and contact the blade. Avoid mowing in wet conditions.
- Before you start the engine, ensure that all drives are in neutral, the parking brake is engaged, and you are in the operating position.
- Ensure that you have good footing while using this machine, especially when backing up.
- Keep your hands and feet away from the cutting units. Keep clear of the discharge opening at all times.
- Look behind and down before backing up to be sure of a clear path.
- Use extreme care when approaching blind corners, shrubs, trees, or other objects that may block your view.
- Stop the blades whenever you are not mowing.
- Stop the machine, remove the ignition key, and wait for all moving parts to stop before inspecting the mower deck or attachment after striking an object or if there is an abnormal vibration in the machine. Make all necessary repairs before resuming operation.
- Slow down and use caution when making turns and crossing roads and sidewalks with the machine. Always yield the right-of-way.

- Disengage the cutting unit and shut off the engine before adjusting the height of cut (unless you can adjust it from the operating position).
- Operate the engine only in well-ventilated areas. Exhaust gases contain carbon monoxide, which is lethal if inhaled.
- Never leave a running machine unattended.
- Before leaving the operating position (including to empty the catchers or to unclog the chute), do the following:
  - Park the machine on a level surface.
  - Disengage the power take-off.
  - Engage the parking brake.
  - Shut off the engine and remove the ignition key.
  - Wait for all moving parts to stop.
- Shut off the machine and disengage the drive to the cutting unit in the following situations:
  - Before fueling
  - Before clearing blockages
  - Before checking, cleaning, or maintaining the cutting unit
  - After striking a foreign object or if an abnormal vibration occurs. Inspect the cutting unit for damage and make repairs before starting and operating the machine
  - Before leaving the operating position
- Do not use the machine as a towing vehicle.
- Use only accessories and attachments approved by The Toro® Company.

## Slope Safety

- Slopes are a major factor related to loss of control and rollover accidents, which can result in severe injury or death. You are responsible for safe slope operation. Operating the machine on any slope requires extra caution. Before using the machine on a slope, do the following:
  - Review and understand the slope instructions in the manual and on the machine.
  - Evaluate the site conditions of the day to determine if the slope is safe for machine operation. Use common sense and good judgment when performing this evaluation. Changes in the terrain, such as moisture, can quickly affect the operation of the machine on a slope.
- Operate across slopes, never up and down. Avoid operation on excessively steep or wet slopes.
- Identify hazards at the base of the slope. Do not operate the machine near drop-offs, ditches, embankments, water, or other hazards. The

machine could suddenly roll over if a wheel goes over the edge or the edge collapses. Keep a safe distance (twice the width of the machine) between the machine and any hazard. Use a walk-behind machine or a handheld tool to operate in these areas.

- Avoid starting, stopping, or turning the machine on slopes. Avoid making sudden changes in speed or direction; turn slowly and gradually.
- Do not operate a machine under any conditions where traction, steering or stability is in question. Be aware that operating the machine on wet grass, across slopes or downhill may cause the machine to lose traction. Loss of traction to the drive wheels may result in sliding and a loss of braking and steering. The machine can slide even if the drive wheels are stopped.
- Remove or mark obstacles such as ditches, holes, ruts, bumps, rocks, or other hidden hazards. Tall grass can hide obstacles. Uneven terrain could overturn the machine.
- Use extra care while operating with accessories or attachments. These can change the stability of the machine and cause a loss of control. Follow directions for counterweights.
- If you lose control of the machine, step off and away from the direction of travel of the machine.

## Operating the Parking Brake

Always engage the parking brake when you shut off the machine or leave it unattended. Before each use, check the parking brake for proper operation.

If the parking brake does not hold securely, adjust it; refer to [Adjusting the Brakes \(page 42\)](#).

Pull the parking-brake lever rearward to engage it ([Figure 7](#)).

Push the parking-brake lever forward to disengage it.

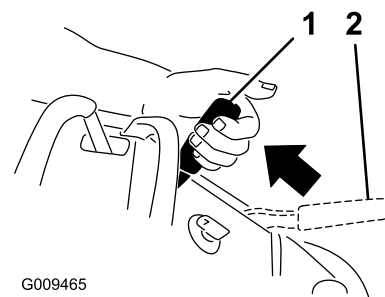

**Figure 7**

1. Parking brake—engaged
2. Parking brake—disengaged

# Operating the PTO

Use the power-takeoff (PTO) switch in conjunction with the motion-control levers to engage and disengage mower blades or powered attachments.

## Engaging the Power-Takeoff (PTO) Switch

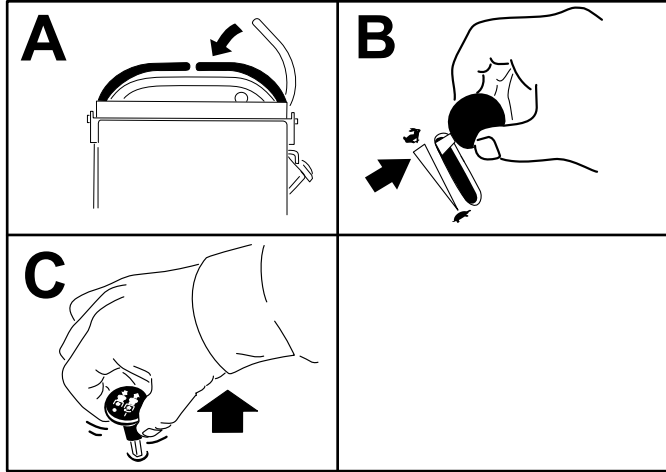

Figure 8

g216326

## Disengaging the Power-Takeoff (PTO) Switch

Figure 9 and Figure 10 show 2 ways to disengage the PTO.

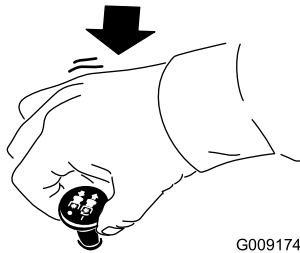

Figure 9

G009174

g009174

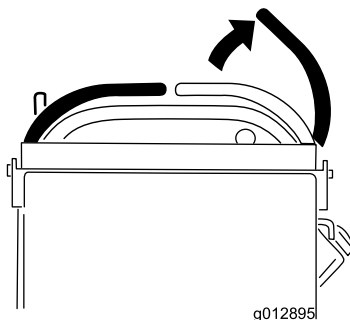

Figure 10

g012895

g012895

# Operating the Throttle

You can move the throttle control between FAST and SLOW positions (Figure 11).

Always use the FAST position when engaging the PTO.

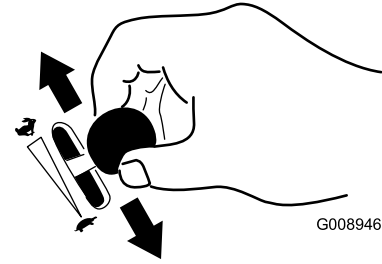

Figure 11

G008946

g008946

# Operating the Choke

Use the choke to start a cold engine.

1. Pull up the choke knob to engage the choke before using the key switch (Figure 12).
2. Push down the choke knob to disengage the choke after the engine has started (Figure 12).

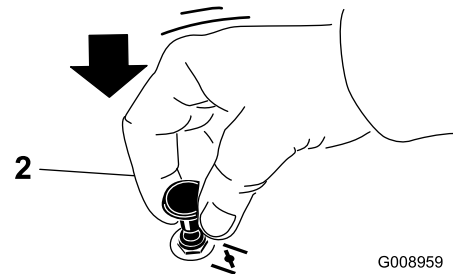
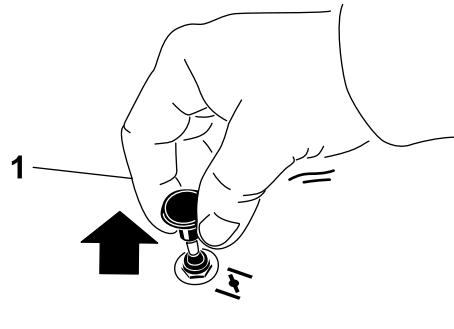

Figure 12

G008959

g008959

1. ON position

2. OFF position

# Operating the Ignition Switch

**Important:** Do not engage the starter for more than 5 seconds at a time. If the engine fails to start, wait 15 seconds between attempts. Failure to follow these instructions can burn out the starter motor.

**Note:** You may need to repeat the cycle for starting the engine when you start it for the first time after you have filled a completely empty fuel system with fuel.

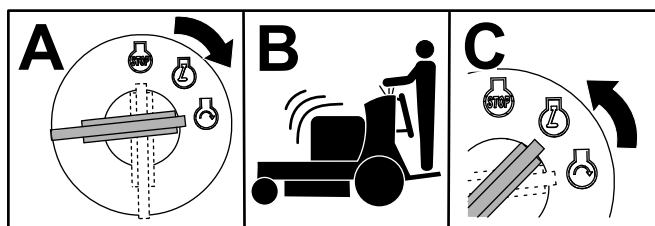

G031239  
g031239

Figure 13

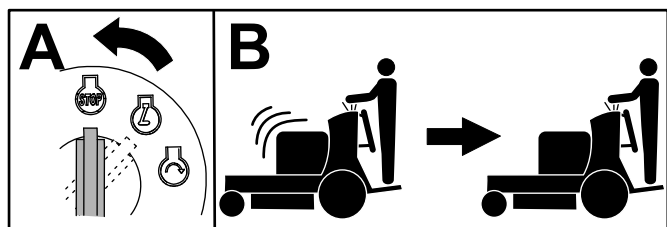

G031281  
g031281

Figure 14

# Starting the Engine

**Important:** Do not engage the starter for more than 5 seconds at a time. If the engine fails to start, wait 15 seconds between attempts. Failure to follow these instructions can burn out the starter motor.

**Note:** A warm or hot engine may not require choking.

**Note:** You may need to repeat the cycle for starting the engine when you start it for the first time after you have filled a completely empty fuel system with fuel.

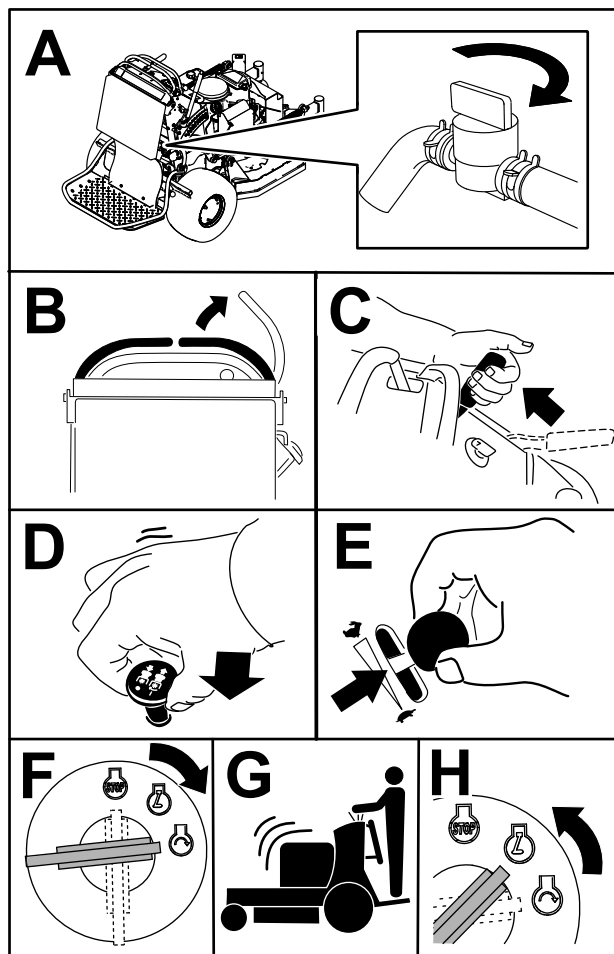

g277435

Figure 15

# Shutting Off the Engine

## ⚠ CAUTION

Children or bystanders may be injured if they move or attempt to operate the machine while it is unattended.

Always remove the key and engage the parking brake when leaving the operator's position.

Let the engine idle at slow throttle (turtle) for 60 seconds before turning the key switch to the OFF position.

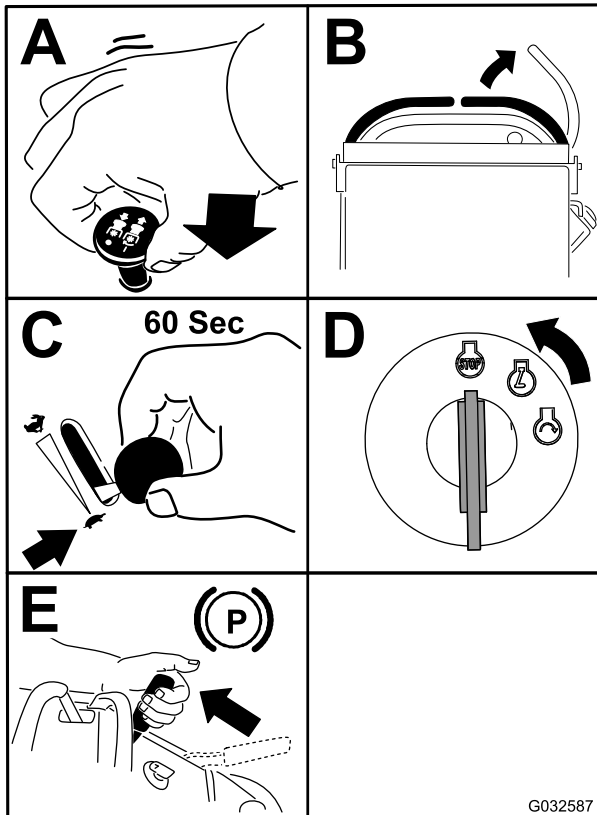

Figure 16

**Important:** Make sure that the fuel-shutoff valve is closed before transporting or storing the machine to prevent a fuel leak. Before storing the machine, disconnect the spark plug(s) to prevent the possibility of accidental starting.

# Operating the Platform

You can use the machine with the platform in the up or down position. It is your preference on which position to use.

## ⚠ WARNING

The operator platform is heavy and may cause injury when you raise or lower it. Carefully lower or raise the operator platform, as suddenly dropping it could injure you.

- Do not put your hands or fingers in the platform-pivot area when lowering or raising the operator platform.
- Make sure that the platform is supported when you pull the latch pin out.
- Make sure that the latch secures the platform when folding it up. Push it tight against the cushion for the latch pin to lock into place.
- Keep bystanders away from the machine when raising or lowering the platform.

## Operating the Machine with the Platform Up

Operate the machine with the platform up for the following conditions:

- Using the machine near drop-offs
- Using the machine in small areas where the machine is too large
- Areas with low-hanging branches or obstacles
- Loading the machine for transport
- Driving up slopes

To raise the platform, pull the back of the platform up so that the latch pin and knob lock it into place. Push it tight against the cushion for the latch pin to lock it into place.

## Operating the Machine with the Platform Down

Operate the machine with the platform down for the following conditions:

- Using the machine in most areas
- Driving across slopes
- Driving down slopes

To lower the platform, push the platform forward against the cushion to release pressure on the latch pin, then pull the knob out and lower the platform (Figure 17).



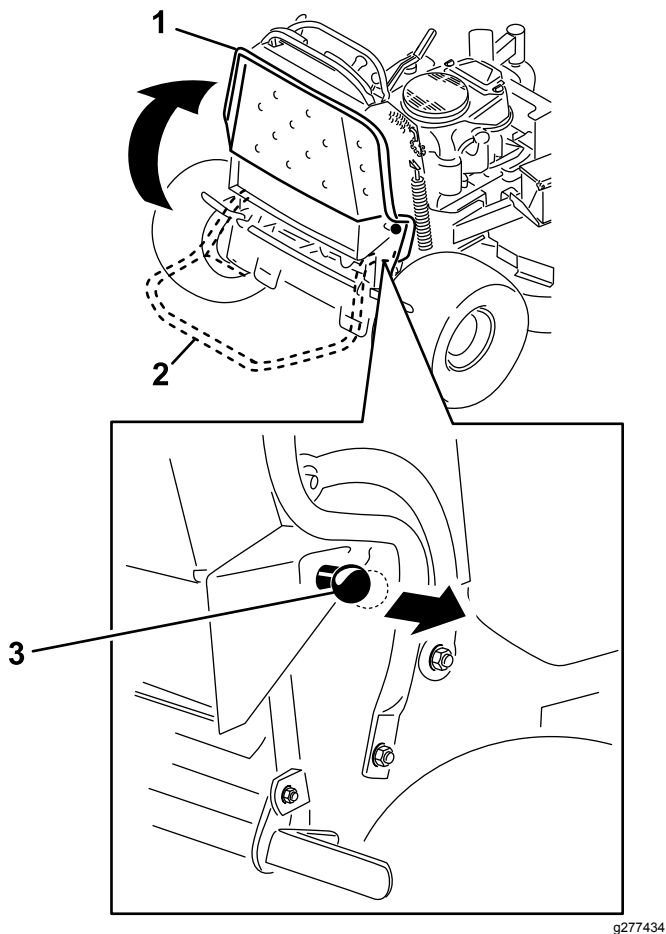

Figure 17

g277434

1. Platform up
2. Platform down
3. Pull the knob out to release the platform.

## Driving Forward or Backward

The throttle control regulates the engine speed as measured in rpm (revolutions per minute). Place the throttle control in the FAST position for best performance.

### ⚠ CAUTION

The machine can spin very rapidly, and you may lose control of the machine, causing personal injury to you and damage to the machine.

Slow the machine down before making sharp turns.

### Driving Forward

1. Disengage the parking brake; refer to [Operating the Parking Brake \(page 13\)](#).

2. Move the right motion-control lever to the center, unlocked position.

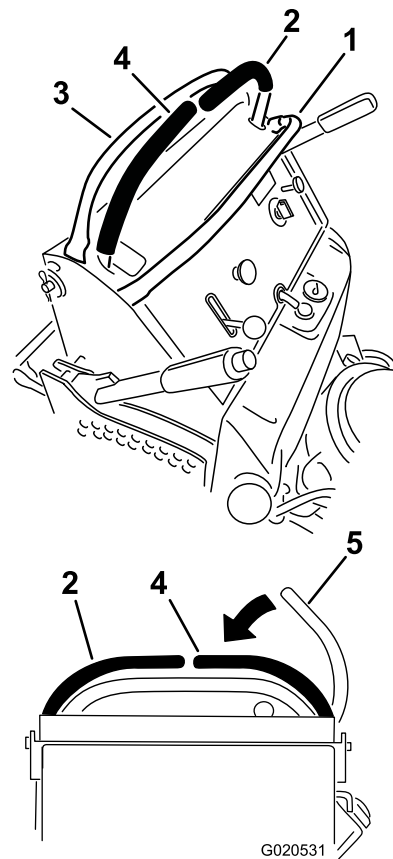

Figure 18

G020531

g020531

1. Front reference bar
2. Left motion-control lever
3. Rear reference bar
4. Right motion-control lever
5. Right motion-control lever in the NEUTRAL-LOCK position

3. Move the speed-control lever to the desired speed.
4. Slowly push the motion-control levers forward ([Figure 19](#)).

**Note:** The engine shuts off if you move a motion-control lever with the parking brake engaged.

**Note:** The farther you move the motion-control levers in either direction, the faster the machine moves in that direction.

**Note:** To stop, pull the motion-control levers back to the NEUTRAL position.

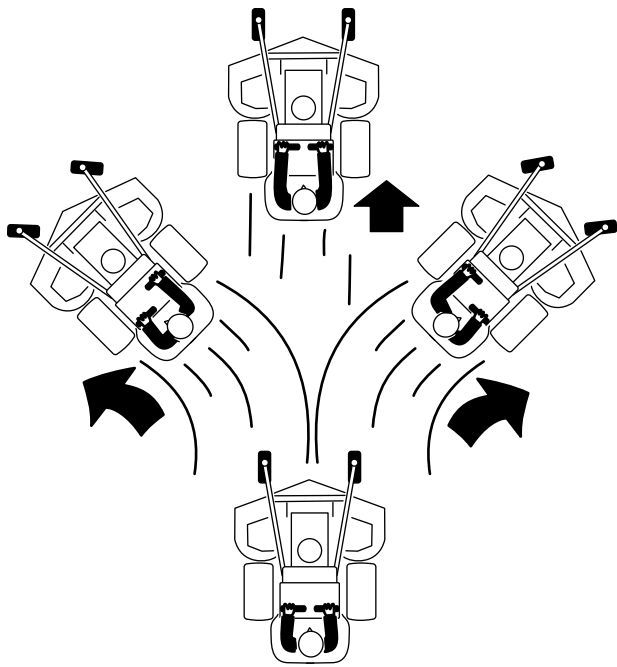

Figure 19

g273674

## Driving Backward

1. Move the right motion-control lever to the center, unlocked position.
2. Slowly pull the motion-control levers rearward (Figure 20).

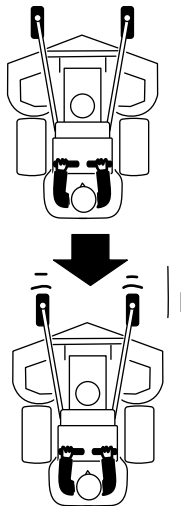

Figure 20

g273673

## Adjusting the Height of Cut

The height of cut can be adjusted from 25 to 127 mm (1 to 5 inches) in 6 mm (1/4 inch) increments.

1. Move the height-of-cut lever to the transport position (all the way up).

2. Rotate the pin 90 degrees and remove it from the height-of-cut bracket.
3. Select a hole in the height-of-cut bracket corresponding to the height-of-cut desired and insert the pin (Figure 21).
4. Push the button on top and lower the height-of-cut lever to the pin (Figure 21).

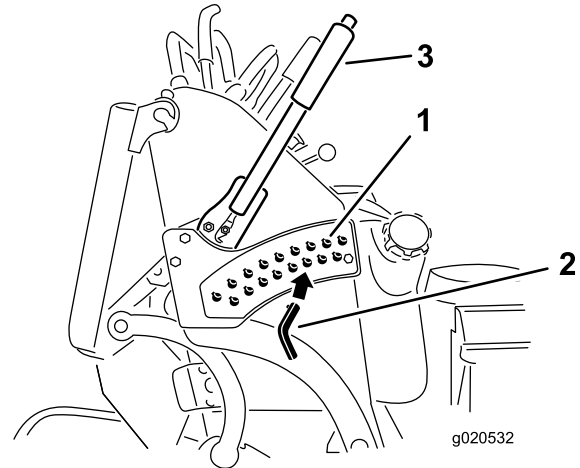

Figure 21

g020532

g020532

1. Height-of-cut holes
2. Height-of-cut pin
3. Height-of-cut lever

## Using Weights

- Install weights to improve balance. You can add or remove weights to create optimized performance under different operating conditions and for your preference.
- Add or remove weights 1 at a time until you achieve the desired handling and balance.
- Refer to the *Operator's Manual* of attachments for recommended weights.

**Note:** Contact an Authorized Service Dealer to order a weight kit.

### **⚠ WARNING**

**Excessive weight changes can affect the handling and operation of the machine. This could cause serious injury to you or bystanders.**

- **Make weight changes in small increments only.**
- **Evaluate the machine after each weight change to ensure that you can operate the machine safely.**

# After Operation

## After Operation Safety

### General Safety

- Always shut off the machine, remove the ignition key, wait for all moving parts to stop, and allow the machine to cool before adjusting, servicing, cleaning, or storing it.
- Clean grass and debris from the cutting units, mufflers, and engine compartment to help prevent fires. Clean up oil or fuel spills.
- Shut off the fuel before storing or transporting the machine.
- Disengage the PTO whenever you are transporting or not using the machine.
- Never store the machine or fuel container where there is an open flame, spark, or pilot light, such as on a water heater or on other appliances.
- Use full-width ramps for loading the machine into a trailer or truck.
- Tie the machine down securely using straps, chains, cable, or ropes. Both front and rear straps should be directed down and outward from the machine.

## Using the Fuel-Shutoff Valve

Close the fuel-shutoff valve for transport, maintenance, and storage (Figure 22).

Ensure that the fuel-shutoff valve is open when starting the engine.

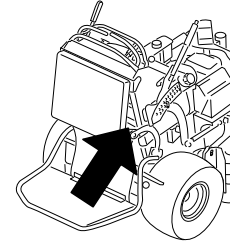

g277457

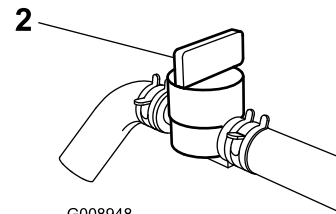
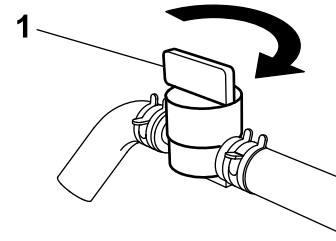

G008948

g008948

**Figure 22**

1. ON position

2. OFF position

# Pushing the Machine by Hand

The bypass valves allow you to push the machine by hand without the engine running.

**Important:** Always push the machine by hand. Do not tow the machine, because hydraulic damage may occur.

**Important:** Do not start or operate the machine with the bypass valves open. Damage to the system may occur.

1. Disengage the PTO, move the motion-control levers to the NEUTRAL-LOCK position, and engage the parking brake.
2. Lower the mower deck to the lowest height of cut (HOC).  
**Note:** This allows access to the bypass valves.
3. Open the bypass valve on both pumps by turning them counterclockwise 1 to 2 turns (Figure 23).

**Note:** This allows hydraulic fluid to bypass the pumps and the wheels to turn.

**Note:** Rotate the bypass valves a maximum of 2 turns so that the valve does not come out of the body, causing fluid to run out.

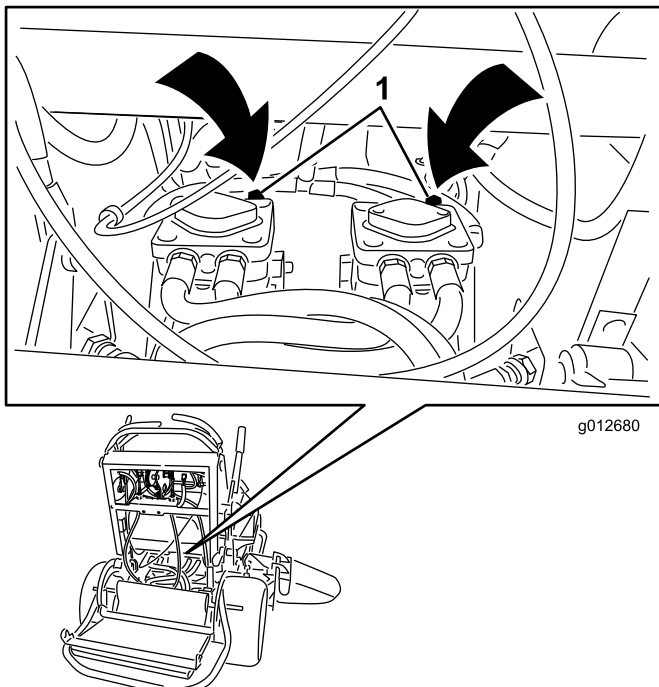

Figure 23

1. Pump-bypass valve

4. Disengage the parking brake.
5. Push the machine to the desired location.

6. Engage the parking brake.
7. Close the bypass valves but do not overtighten them.
8. Torque the valves to 12 to 15 N·m (110 to 130 in-lb).

## Transporting the Machine

Use a heavy-duty trailer or truck to transport the machine. Use a full-width ramp. Ensure that the trailer or truck has all the necessary brakes, lighting, and marking as required by law. Please carefully read all the safety instructions. Knowing this information could help you or bystanders avoid injury. Refer to your local ordinances for trailer and tie-down requirements.

### ⚠ WARNING

**Driving on the street or roadway without turn signals, lights, reflective markings, or a slow-moving-vehicle emblem is dangerous and can lead to accidents, causing personal injury.**

**Do not drive the machine on a public street or roadway.**

## Selecting a Trailer

### ⚠ WARNING

**Loading a machine onto a trailer or truck increases the possibility of tip-over and could cause serious injury or death (Figure 24).**

- Use only a full-width ramp; do not use individual ramps for each side of the machine.
- Ensure that the length of ramp is at least 4 times as long as the height of the trailer or truck bed to the ground.

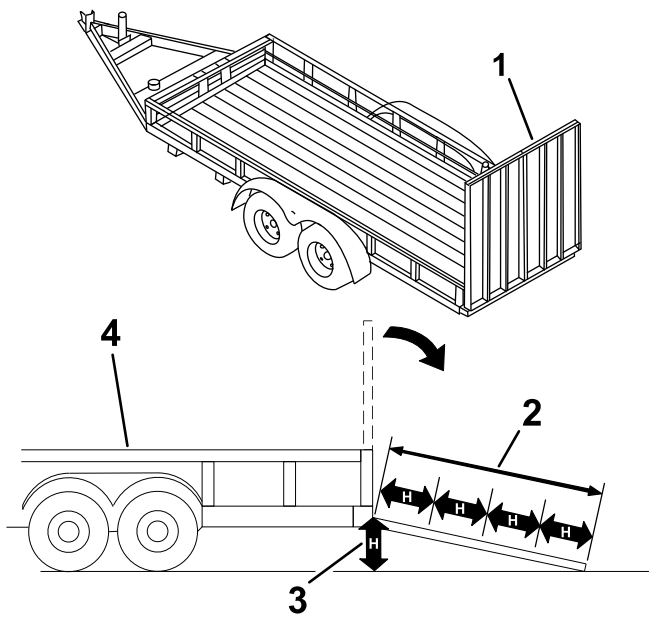

Figure 24

g229507

1. Full-width ramp in stowed position
2. Ramp is at least 4 times as long as the height of the trailer or truck bed to the ground
3. H=height of the trailer or truck bed to the ground
4. Trailer

## Loading the Machine

### **⚠ WARNING**

Loading a machine onto a trailer or truck increases the possibility of tip-over and could cause serious injury or death.

- Use extreme caution when operating a machine on a ramp.
- Back the machine up the ramp and walk it forward down the ramp.
- Avoid sudden acceleration or deceleration while driving the machine on a ramp as this could cause a loss of control or a tip-over situation.

1. If using a trailer, connect it to the towing vehicle and connect the safety chains.
2. If applicable, connect the trailer brakes and lights.
3. Lower the ramp (Figure 24).
4. Raise the platform.

**Important:** Always keep the platform up when loading and unloading the machine.

5. Back the machine up the ramp (Figure 25).

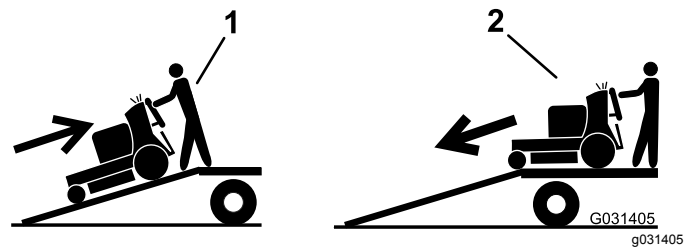

Figure 25

1. Back the machine up the ramp.
2. Walk the machine down the ramp.

6. Shut off the engine, remove the key, and engage the parking brake.
7. Tie down the machine near the front caster wheels and the rear bumper with straps, chains, cable, or ropes (Figure 26). Refer to local regulations for tie-down requirements.

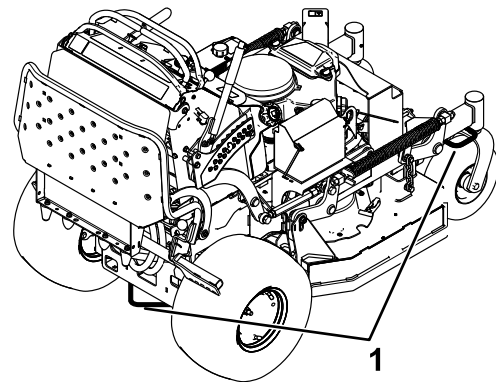

Figure 26

g277456

1. Tie-down loops

# Maintenance

**Note:** Determine the left and right sides of the machine from the normal operating position.

## **⚠ CAUTION**

**If you leave the ignition key in the switch, someone could accidentally start the engine and seriously injure you or other bystanders.**

**Remove the ignition key from the switch before you perform any maintenance.**

## Maintenance Safety

- Before adjusting, cleaning, servicing, or leaving the machine, do the following:
  - Park the machine on a level surface.
  - Disengage the drives.
  - Engage the parking brake.
  - Shut off the engine and remove the ignition key.
  - Wait for all moving parts to stop.
  - Allow machine components to cool before performing maintenance.
- Do not allow untrained personnel to service the machine.
- Keep your hands and feet away from moving parts. If possible, do not make adjustments with the engine running.
- Carefully release pressure from components with stored energy.
- Check the parking brake operation frequently. Adjust and service the brake as needed.
- Never tamper with safety devices. Check their proper operation regularly.
- Clean grass and debris from the cutting unit, drives, muffler, and engine to help prevent fires. Clean up oil or fuel spills.
- Check the grass catcher components frequently and replace them when they are worn or damaged.
- Do not rely on a hydraulic system to support the machine; support the machine with jack stands whenever you raise the machine.
- Keep all parts in good working condition and all hydraulic fittings tight. Replace all worn, damaged, or missing parts and decals. Keep all fasteners tight to ensure that the machine is in safe working condition.
- To ensure optimum performance and continued safety certification of the machine, use only genuine Toro replacement parts and accessories. Replacement parts and accessories made by other manufacturers could be dangerous, and such use could void the product warranty.

# Recommended Maintenance Schedule(s)

Maintenance Service Interval	Maintenance Procedure
After the first 8 hours	<ul style="list-style-type: none"> <li>• Change the engine oil.</li> <li>• Check the hydraulic fluid level.</li> <li>• Change the hydraulic filter.</li> </ul>
Before each use or daily	<ul style="list-style-type: none"> <li>• Check the safety-interlock system.</li> <li>• Check the engine-oil level.</li> <li>• Clean the air-intake screen (more often in dirty or dusty conditions).</li> <li>• Test the parking brake.</li> <li>• Check the brake clearance.</li> <li>• Inspect the blades.</li> <li>• Clean under the mower deck.</li> <li>• Clean debris from rear wheel motors.</li> </ul>
Every 25 hours	<ul style="list-style-type: none"> <li>• Clean foam air-cleaner element (more often in dirty or dusty conditions).</li> </ul>
Every 50 hours	<ul style="list-style-type: none"> <li>• Grease the mower-deck idler arms (more often in dirty or dusty conditions).</li> <li>• Grease the lift linkage (more often in dirty or dusty conditions).</li> <li>• Check the spark arrester (if equipped).</li> <li>• Check the tire pressure.</li> <li>• Check the hydraulic fluid level.</li> </ul>
Every 100 hours	<ul style="list-style-type: none"> <li>• Clean the paper air-cleaner element (more often in dirty or dusty conditions).</li> <li>• Change the engine oil.</li> <li>• Check, clean and gap the spark plug.</li> <li>• Check the battery.</li> <li>• Check the electric clutch.</li> <li>• Check and clean engine cooling fins and shrouds (more often in dirty or dusty conditions).</li> <li>• Check the mower-deck belt(s).</li> <li>• Check the pump-drive belt.</li> <li>• Check the hydraulic hoses.</li> </ul>
Every 200 hours	<ul style="list-style-type: none"> <li>• Replace the paper air-cleaner element (more often in dirty or dusty conditions).</li> <li>• Change the engine-oil filter.</li> </ul>
Every 250 hours	<ul style="list-style-type: none"> <li>• Change the hydraulic fluid when using Mobil® 1 oil.</li> </ul>
Every 300 hours	<ul style="list-style-type: none"> <li>• Check and adjust the valve clearance. See an Authorized Service Dealer.</li> </ul>
Every 500 hours	<ul style="list-style-type: none"> <li>• Adjust the caster-pivot bearing.</li> <li>• Change the hydraulic fluid when using Toro® HYPR-OIL™ 500 hydraulic fluid.</li> <li>• Change the hydraulic filter.</li> </ul>
Every 800 hours	<ul style="list-style-type: none"> <li>• Replace the fuel filter.</li> </ul>
Before storage	<ul style="list-style-type: none"> <li>• Paint chipped surfaces.</li> <li>• Paint chipped surfaces.</li> <li>• Perform all maintenance procedures listed above before storage.</li> </ul>
Yearly	<ul style="list-style-type: none"> <li>• Grease the front caster pivots (more often in dirty or dusty conditions).</li> <li>• Grease the caster-wheel hubs.</li> <li>• Inspect the blade bolts and curved washers. Replace if damaged.</li> </ul>

**Important:** Refer to your engine owner's manual for additional maintenance procedures.

# Pre-Maintenance Procedures

## Raising the Mower for Access

You can raise the front of the mower and support it on its back for access under the machine for maintenance.

1. Park the machine on a level surface, disengage the PTO, and engage the parking brake.
2. Shut off the engine, remove the key, and wait for all moving parts to stop before leaving the operating position.
3. Raise the platform; refer to [Operating the Platform \(page 16\)](#).
4. Remove the battery; refer to [Removing the Battery \(page 34\)](#).

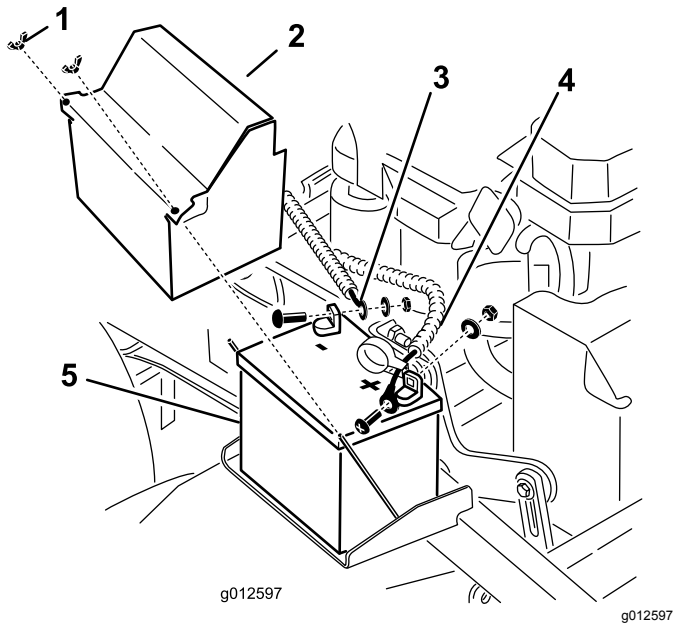

Figure 27

1. Wing nut
2. Battery cover
3. Negative (-) battery cable
4. Positive (+) battery cable
5. Battery

5. Drain the fuel from the fuel tank; refer to [Draining the Fuel Tank \(page 33\)](#).
6. Remove the cap of the hydraulic tank and place a piece of plastic over the opening and install the hydraulic cap ([Figure 28](#)).

**Note:** This seals the hydraulic tank and prevents it from leaking out.

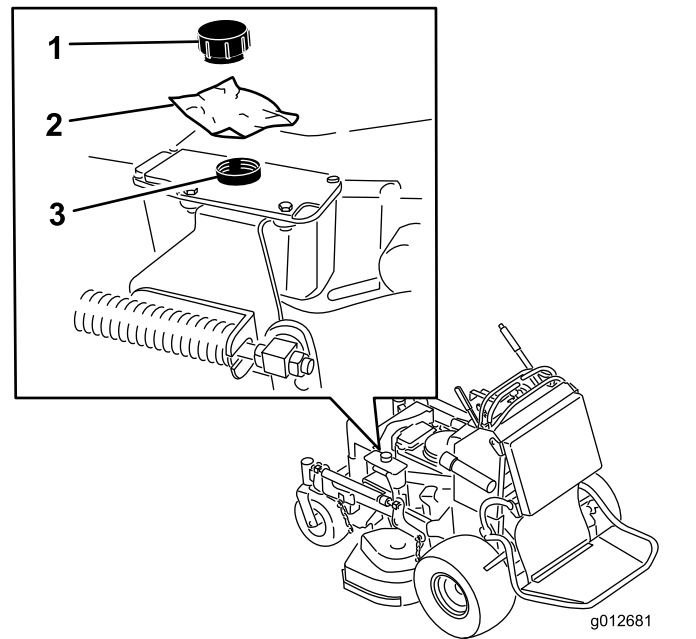
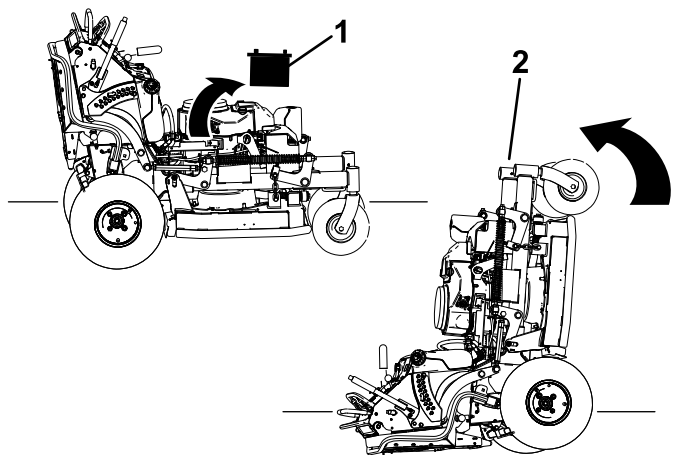

Figure 28

1. Cap
2. Piece of plastic
3. Hydraulic tank

7. With 2 people, raise the front of the mower so that it rests on the drive tires and the platform in the up position ([Figure 29](#)).
8. Perform any maintenance on the machine.
9. With 2 people, lower the front of the mower to the ground.
10. Remove the plastic under the hydraulic-tank cap ([Figure 28](#)).
11. Install the battery for the machine ([Figure 27](#)).





g279050

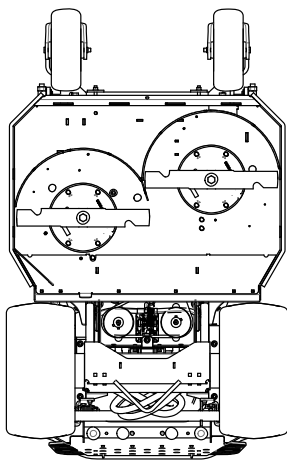

g277482

**Figure 29**

1. Remove the battery.
2. With 2 people, lift the front end of the mower (ensure that the platform is up).

## Releasing the Cushion for Rear Access

You can release the cushion for rear access to the machine for maintenance or adjustment.

1. Lower the platform.
2. Remove the hairpin cotters on each side of the cushion.
3. Slide the large washers with plastic bushings to the inside.
4. Remove the cushion and lower it to the platform.
5. Perform any maintenance or adjustment on the machine.
6. Raise the cushion and slide it onto the pins on both sides of the machine (**Figure 30**).
7. Slide the large washers with plastic bushings into the cushion bracket and secure them with a hairpin-cotter pin (**Figure 30**).

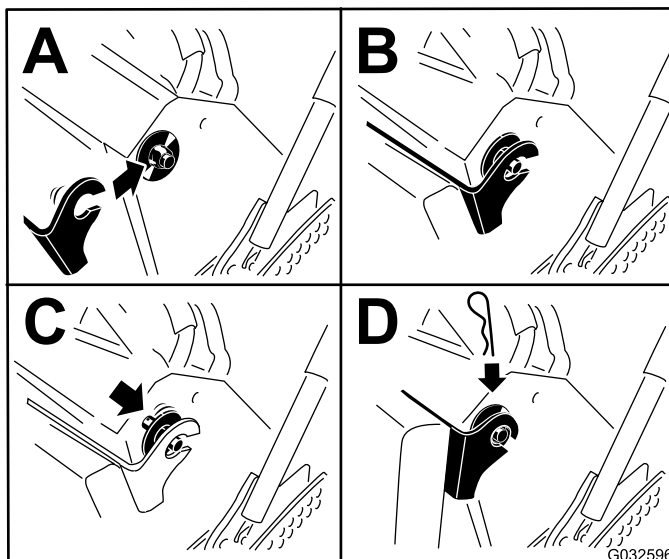

G032596

g032596

**Figure 30**

# Removing the Belt Covers

Reverse the procedure to install the covers.

1. Loosen the 2 shoulder bolts and the screw (Figure 31).

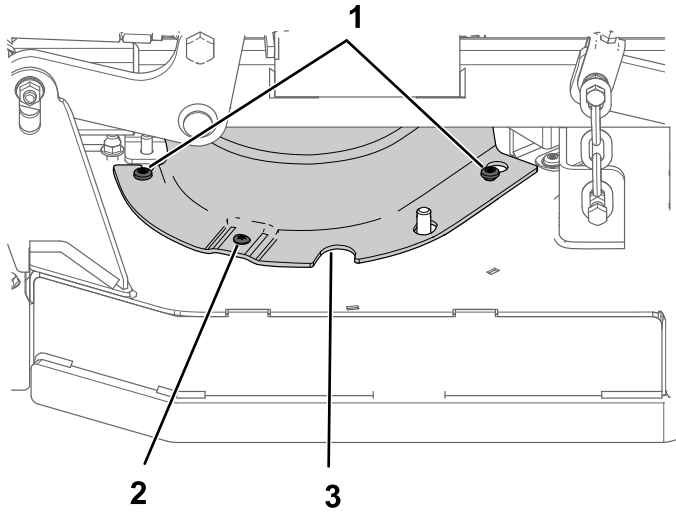

Figure 31

g277768

1. Shoulder bolt
2. Screw
3. Belt cover

2. Remove the cover.

# Removing the Deck Guards

Reverse the procedure to install the guards.

1. Remove the belt covers; refer to [Removing the Belt Covers](#) (page 26).
2. On the right side of the machine, remove the washer-head bolts (1/4 x 3/4 inch) and loosen the shoulder bolt (Figure 32). Remove the guard.

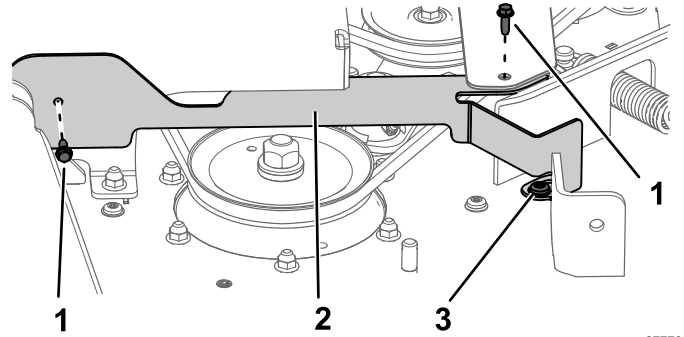

Figure 32

g277769

1. Washer-head bolt
2. Right deck guard
3. Shoulder bolt

3. On the left side of the machine, remove the washer-head bolt and loosen the shoulder bolt. Remove the guard.

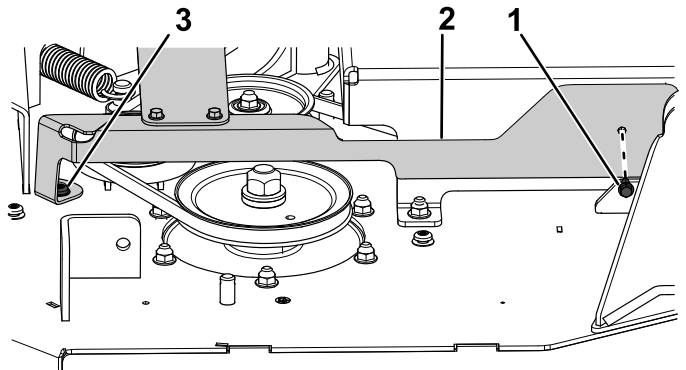

Figure 33

g277917

1. Washer-head bolt
2. Left deck guard
3. Shoulder bolt

# Lubrication

## Greasing the Machine

**Service Interval:** Every 50 hours—Grease the mower-deck idler arms (more often in dirty or dusty conditions).

Every 50 hours—Grease the lift linkage (more often in dirty or dusty conditions).

**Grease type:** Lithium or molybdenum grease

1. Park the machine on a level surface, disengage the PTO, and engage the parking brake.
2. Shut off the engine, remove the key, and wait for all moving parts to stop before leaving the operating position.
3. Clean the grease fittings with a rag.

**Note:** Scrape any paint off the front of the fitting(s).

4. Connect a grease gun to the fitting.
5. Pump grease into the fittings until grease begins to ooze out of the bearings.
6. Wipe up any excess grease.

Use [Figure 34](#) and [Figure 35](#) for locating the grease points.

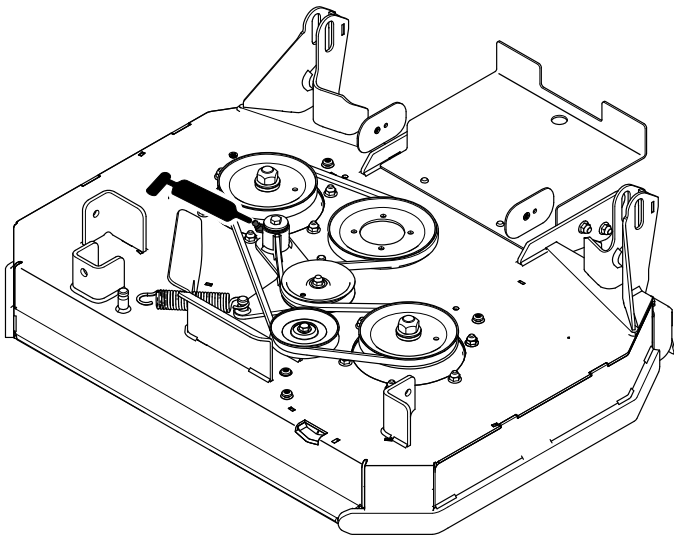

Figure 34

g277525

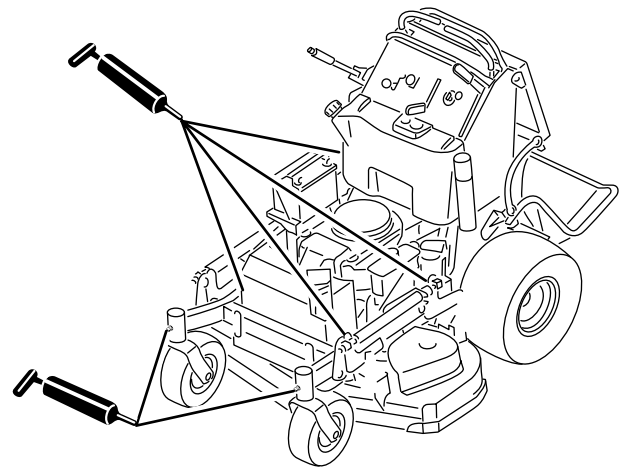

Figure 35

g277524

## Greasing the Front Caster Pivots

**Service Interval:** Yearly

**Grease type:** Lithium or molybdenum grease

1. Remove the dust cap and adjust the caster pivots; refer to [Adjusting the Caster-Pivot Bearing](#) (page 39).

**Note:** Keep the dust cap off until you have finished greasing the caster pivots.

2. Remove the hex plug.
3. Thread a grease fitting (1/4 inch–28 taper thread) into the hole.
4. Pump grease into the fitting until it oozes out around the top bearing.
5. Remove the grease fitting from the hole.
6. Install the hex plug and dust cap.

# Greasing the Caster-Wheel Hubs

**Service Interval:** Yearly

**Grease type:** Lithium or molybdenum grease

1. Park the machine on a level surface, disengage the PTO, and engage the parking brake.
2. Shut off the engine, remove the key, and wait for all moving parts to stop before leaving the operating position.
3. Remove the caster wheel from the caster forks.
4. Remove the seal guards from the wheel hub (Figure 36).

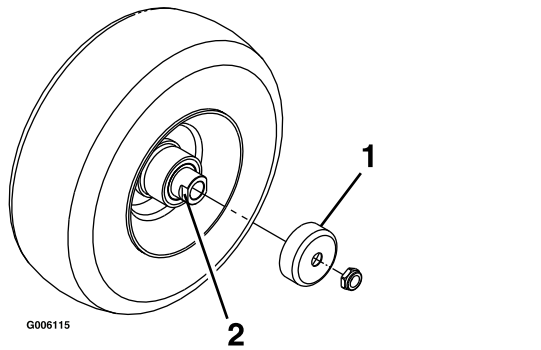

Figure 36

1. Seal guard
2. Spacer nut with wrench flats

10. Insert the assembled nut and axle into the wheel on the side of the wheel with the new seal and bearing.
11. With the open end of the wheel facing up, fill the area inside the wheel around the axle full of general-purpose grease.
12. Insert the second bearing and the new seal into the wheel.
13. Apply a thread-locking adhesive to the second spacer nut, threading it onto the axle with the wrench flats facing outward.
14. Torque the nut to 8 to 9 N·m (71 to 80 in-lb), loosen it, then torque it to 2 to 3 N·m (20 to 25 in-lb).

**Note:** Make sure that the axle does not extend beyond either nut.

15. Install the seal guards over the wheel hub and insert the wheel into the caster fork.
16. Install the caster bolt and tighten the nut fully.

**Important:** To prevent seal and bearing damage, check the bearing adjustment often by spinning the caster wheel. The wheel should not spin freely (more than 1 or 2 revolutions) or have any side play. If the wheel spins freely, adjust the torque on the spacer nut until there is a slight amount of drag, and apply thread-locking adhesive.

5. Remove 1 spacer nut from the axle assembly in the caster wheel.

**Note:** Thread-locking adhesive has been applied to lock the spacer nuts to the axle. Remove the axle (with the other spacer nut still assembled to it) from the wheel assembly.

6. Pry out the seals, inspect bearings for wear or damage, and replace them if necessary.
7. Pack the bearings with a general-purpose grease.
8. Insert 1 bearing and 1 new seal into the wheel.

**Note:** You must replace the seals.

9. If both spacer nuts in the axle assembly have been removed (or broken loose), apply a thread-locking adhesive to 1 spacer nut, threading it onto the axle with the wrench flats facing outward.

**Note:** Do not thread the spacer nut all of the way onto the end of the axle. Leave approximately 3 mm (1/8 inch) from the outer surface of the spacer nut to the end of the axle inside the nut.

# Engine Maintenance

## Engine Safety

- Shut off the engine before checking the oil or adding oil to the crankcase.
- Keep your hands, feet, face, clothing, and other body parts away from the muffler and other hot surfaces.

## Servicing the Air Cleaner

Inspect the foam and paper elements and replace them if they are damaged or excessively dirty.

**Important:** Do not oil the foam or paper element.

## Removing the Foam and Paper Elements

1. Park the machine on a level surface, disengage the PTO, and engage the parking brake.
2. Shut off the engine, remove the key, and wait for all moving parts to stop before leaving the operating position.
3. Clean around the air cleaner to prevent dirt from getting into the engine and causing damage (Figure 37).
4. Loosen the cover knobs and remove the air-cleaner cover (Figure 37).
5. Loosen the hose clamp and remove the air-cleaner assembly (Figure 37).
6. Carefully pull the foam element off the paper element (Figure 37).

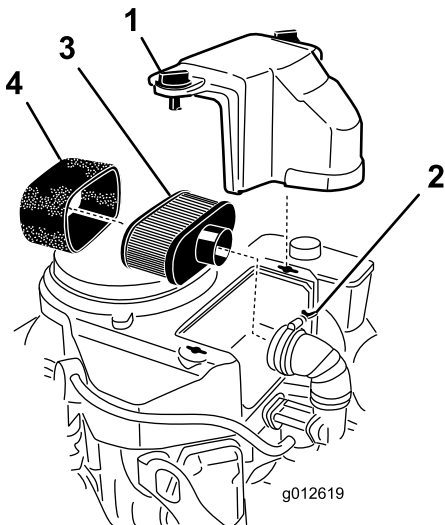

Figure 37

- |               |                  |
|---------------|------------------|
| 1. Cover      | 3. Paper element |
| 2. Hose clamp | 4. Foam element  |

## Cleaning the Foam Air-Cleaner Element

**Service Interval:** Every 25 hours

1. Wash the foam element in liquid soap and warm water. When the element is clean, rinse it thoroughly.
2. Dry the element by squeezing it in a clean cloth.

**Important:** Replace the foam element if it is torn or worn.

## Servicing the Paper Air-Cleaner Element

**Service Interval:** Every 100 hours—Clean the paper air-cleaner element (more often in dirty or dusty conditions).

Every 200 hours—Replace the paper air-cleaner element (more often in dirty or dusty conditions).

1. Clean the paper element by tapping it gently to remove dust.

**Note:** If it is very dirty, replace the paper element with a new one.

2. Inspect the element for tears, an oily film, or damage to the rubber seal.
3. Replace the paper element if it is damaged.

**Important:** Do not clean the paper filter.

## Installing the Foam and Paper Elements

**Important:** To prevent engine damage, always operate the engine with the complete foam and paper air-cleaner assembly installed.

1. Carefully slide the foam element onto the paper air-cleaner element (Figure 37).
2. Place the air-cleaner assembly onto the base of the air cleaner or hose and secure it (Figure 37).
3. Place the air-cleaner cover into position and tighten the cover knob (Figure 37).

# Servicing the Engine Oil

## Engine-Oil Specifications

**Oil Type:** Detergent oil (API service SJ or higher)

**Engine Oil Capacity:** 1.7 L (57 fl oz) with the filter;  
1.5 L (51 fl oz) without the filter

**Viscosity:** Refer to the table below:

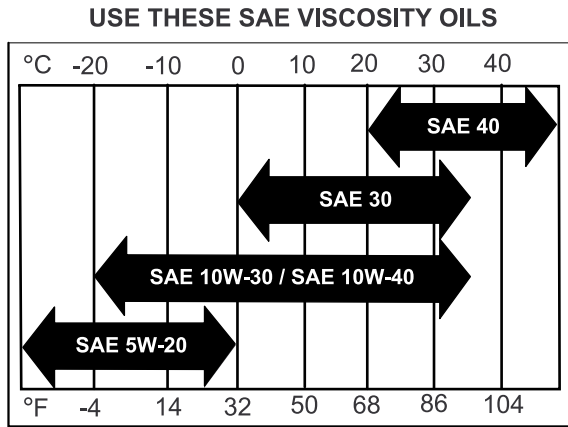
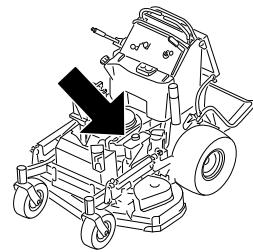

Figure 38



g277606

## Checking the Engine-Oil Level

**Service Interval:** Before each use or daily

**Note:** Check the oil when the engine is cold.

### ⚠ WARNING

Contact with hot surfaces may cause personal injury.

Keep your hands, feet, face, clothing and other body parts away the muffler and other hot surfaces.

**Important:** Do not overfill the crankcase with oil because damage to the engine may result. Do not run engine with oil below the low mark because the engine may be damaged.

1. Park the machine on a level surface, disengage the PTO, and engage the parking brake.
2. Shut off the engine, remove the key, and wait for all moving parts to stop before leaving the operating position.
3. Check the engine-oil level as shown in (Figure 39).

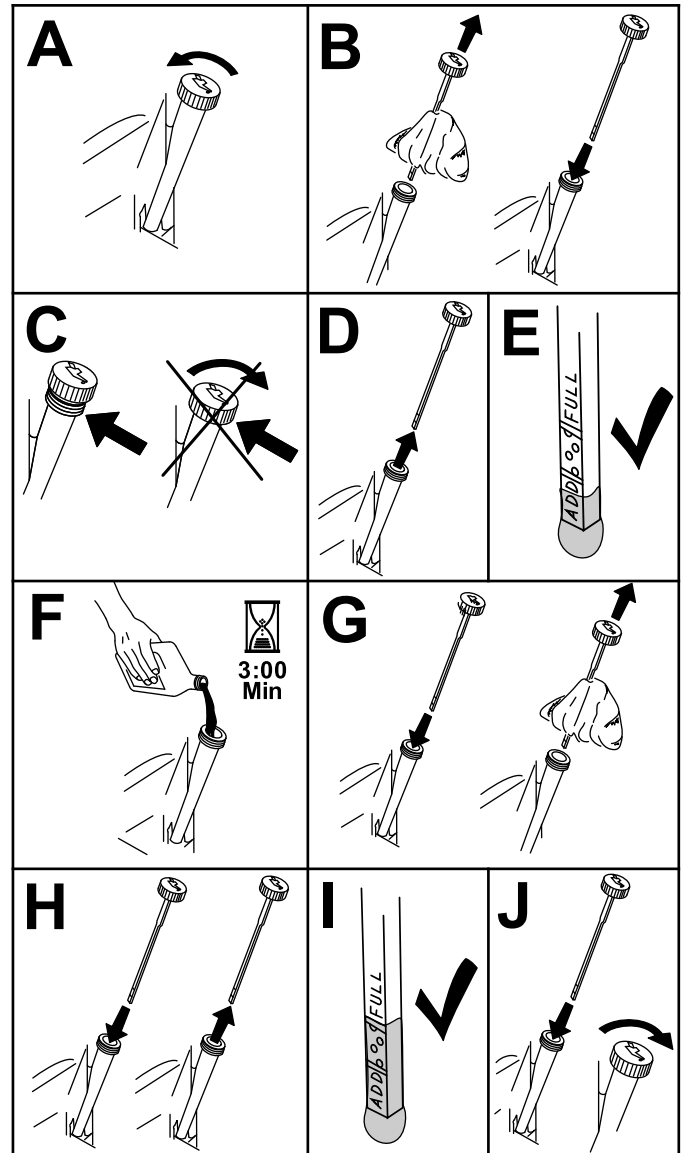

Figure 39

g194611

# Changing the Engine Oil

**Service Interval:** After the first 8 hours

Every 100 hours

**Note:** Dispose of the used oil at a recycling center.

1. Park the machine so that the drain side is slightly lower than the opposite side to assure the oil drains completely.
2. Disengage the PTO, move the motion-control levers to the NEUTRAL-LOCK position, and engage the parking brake.
3. Shut off the engine, remove the key, and wait for all moving parts to stop before leaving the operating position.
4. Change the engine oil as shown in [Figure 40](#).

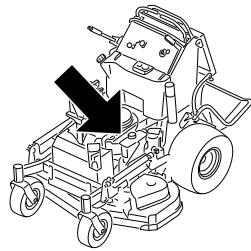

g277606

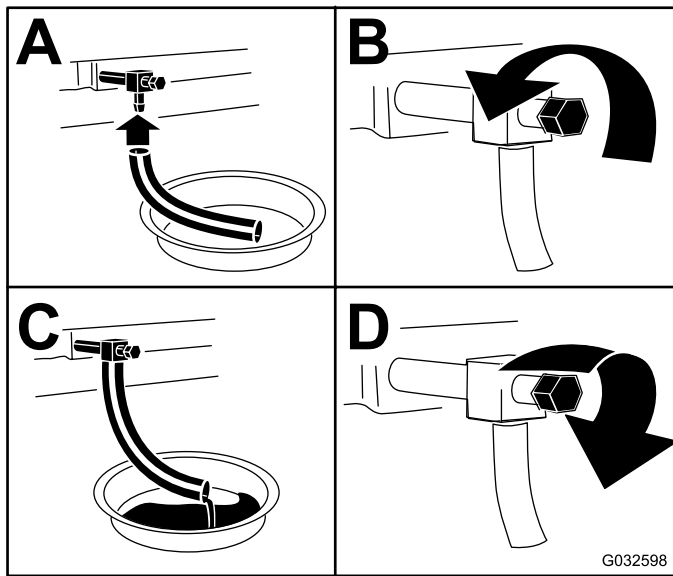

G032598

g032598

**Figure 40**

5. Slowly pour approximately 80% of the specified oil into the filler tube and slowly add the additional oil to bring it to the **Full** mark ([Figure 41](#)).

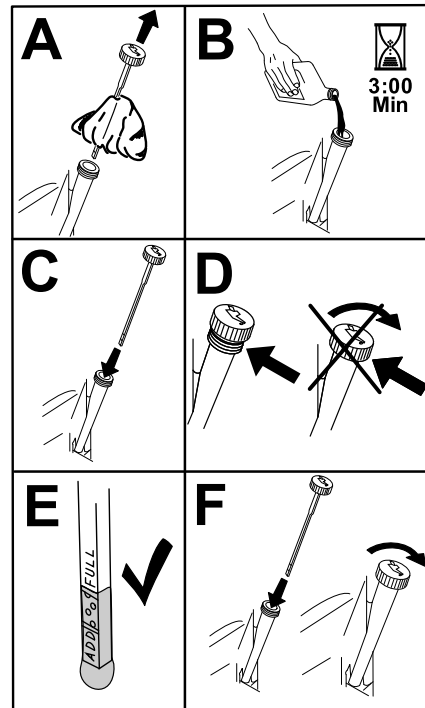

**Figure 41**

g194610

6. Start the engine and drive to a flat area.
7. Check the oil level again.

## Changing the Engine-Oil Filter

**Service Interval:** Every 200 hours

**Note:** Change the engine-oil filter more frequently when operating conditions are extremely dusty or sandy.

1. Drain the oil from the engine; refer to [Changing the Engine Oil \(page 31\)](#).
2. Change the engine-oil filter ([Figure 42](#)).

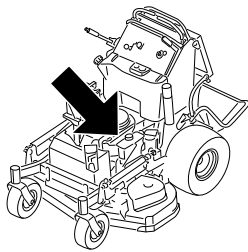

g277606

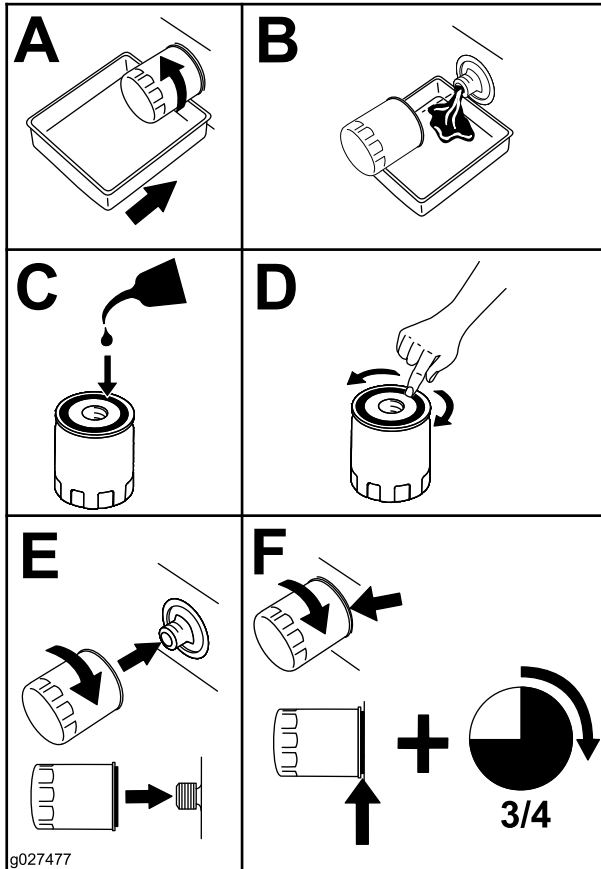

g027477

g027477

Figure 42

**Note:** Ensure that the oil-filter gasket touches the engine, then rotate the filter an extra 3/4 turn.

3. Fill the crankcase with the proper type of new oil; refer to [Engine-Oil Specifications \(page 30\)](#).

## Servicing the Spark Plug

**Service Interval:** Every 100 hours

Ensure that the air gap between the center and side electrodes is correct before installing the spark plug.

Use a spark plug wrench for removing and installing the spark plug(s) and a gapping tool/feeler gauge to check and adjust the air gap. Install a new spark plug(s) if necessary.

**Type:** NGK® BPR4ES or equivalent

**Air gap:** 0.75 mm (0.03 inch)

## Removing the Spark Plug

1. Park the machine on a level surface, disengage the PTO, and engage the parking brake.
2. Shut off the engine, remove the key, and wait for all moving parts to stop before leaving the operating position.
3. Remove the spark plug as shown in [Figure 43](#).

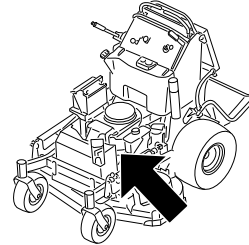

g277607

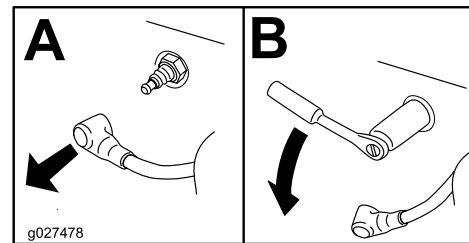

g027478

g027478

Figure 43

## Checking the Spark Plug

**Important:** Do not clean the spark plug(s). Always replace the spark plug(s) when it has a black coating, worn electrodes, an oily film, or cracks.

If you see light brown or gray on the insulator, the engine is operating properly. A black coating on the insulator usually means the air cleaner is dirty.

Set the gap to 0.75 mm (0.03 inch).

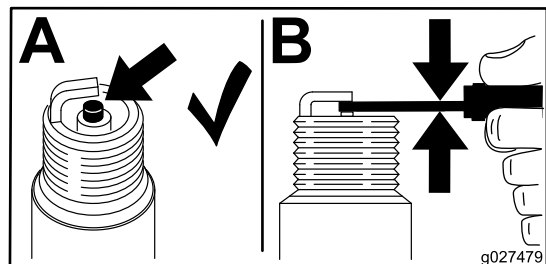

g027479

g027479

Figure 44



## Installing the Spark Plug

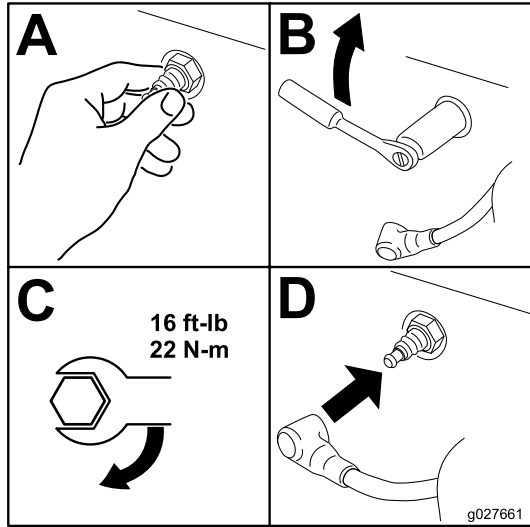

Figure 45

g027661

## Checking the Spark Arrester

### For Machines with a Spark Arrester

Service Interval: Every 50 hours

#### **⚠ WARNING**

Hot exhaust-system components may ignite fuel vapors even after you shut off the engine. Hot particles exhausted during engine operation may ignite flammable materials, resulting in personal injury or property damage.

**Do not refuel or run the engine unless the spark arrester is installed.**

1. Park the machine on a level surface, disengage the PTO, and engage the parking brake.
2. Shut off the engine, remove the key, and wait for all moving parts to stop before leaving the operating position.
3. Wait for the muffler to cool.
4. If you see any breaks in the screen or welds, replace the arrester.
5. If the screen is plugged, remove the arrester, shake loose particles out of the arrester, and clean the screen with a wire brush (soak the screen in solvent if necessary).
6. Install the arrester on the exhaust outlet.

## Fuel System Maintenance

### Draining the Fuel Tank

**Note:** Use a syphon pump to drain fuel from the tank. You can purchase a syphon pump at a hardware store.

#### **⚠ DANGER**

In certain conditions, fuel is extremely flammable and highly explosive. A fire or explosion from fuel can burn you, others, and can damage property.

- Perform any fuel-related maintenance when the engine is cold. Do this outdoors in an open area. Wipe up any fuel that spills.
- Never smoke when draining fuel, and stay away from an open flame or where a spark may ignite the fuel fumes.

1. Park the machine on a level surface, disengage the PTO, and engage the parking brake.
2. Shut off the engine, remove the key, and wait for all moving parts to stop before leaving the operating position.
3. Clean around the fuel cap to prevent debris from getting into the fuel tank (Figure 46).
4. Remove the fuel cap.
5. Insert a syphon pump into the fuel tank.
6. Using the syphon pump, drain the fuel into a clean fuel can (Figure 46).
7. Wipe up any spilled fuel.

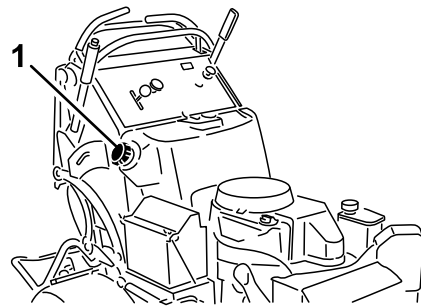

Figure 46

g277622

1. Fuel cap

# Replacing the Fuel Filter

**Service Interval:** Every 800 hours/Yearly (whichever comes first)

Do not install a dirty filter if it is removed from the fuel line.

**Note:** Wipe up any spilled fuel.

1. Park the machine on a level surface, disengage the PTO, and engage the parking brake.
2. Shut off the engine, remove the key, and wait for all moving parts to stop before leaving the operating position.
3. Close the fuel-shutoff valve; refer to [Using the Fuel-Shutoff Valve \(page 19\)](#).
4. Replace the fuel filter as shown in [Figure 47](#).

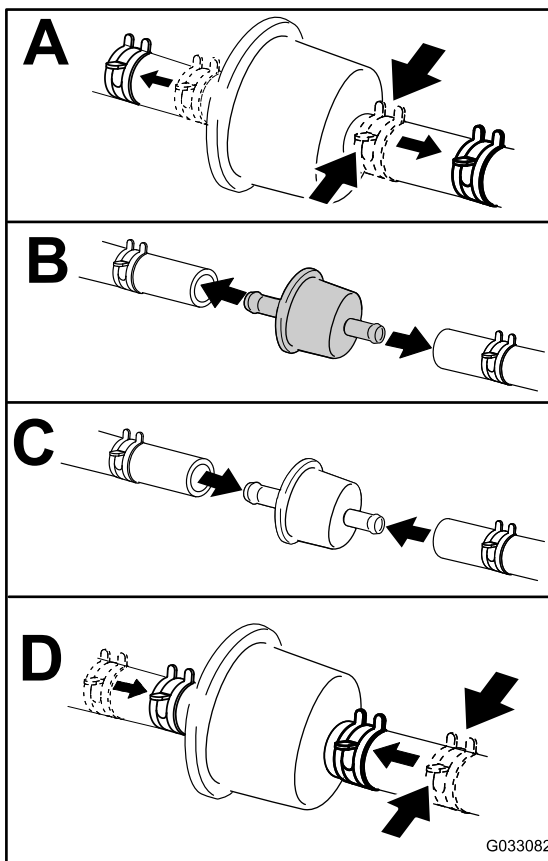

**Figure 47**

G033082

# Electrical System Maintenance

## Electrical System Safety

- Disconnect the battery or remove the spark-plug wire before making any repairs. Disconnect the negative terminal first and the positive terminal last. Connect the positive terminal first and negative last.
- Charge the battery in an open, well-ventilated area, away from sparks and flames. Unplug the charger before connecting or disconnecting the battery. Wear protective clothing and use insulated tools.

## Servicing the Battery

**Service Interval:** Every 100 hours

Always keep the battery clean and fully charged. Use a paper towel to clean the battery case. If the battery terminals are corroded, clean them with a solution of four parts water and 1 part baking soda. Apply a light coating of grease to the battery terminals to prevent corrosion.

Voltage: 12 V

## Removing the Battery

1. Park the machine on a level surface, disengage the PTO, and engage the parking brake.
2. Shut off the engine, remove the key, and wait for all moving parts to stop before leaving the operating position.
3. Remove the battery as shown in [Figure 48](#).

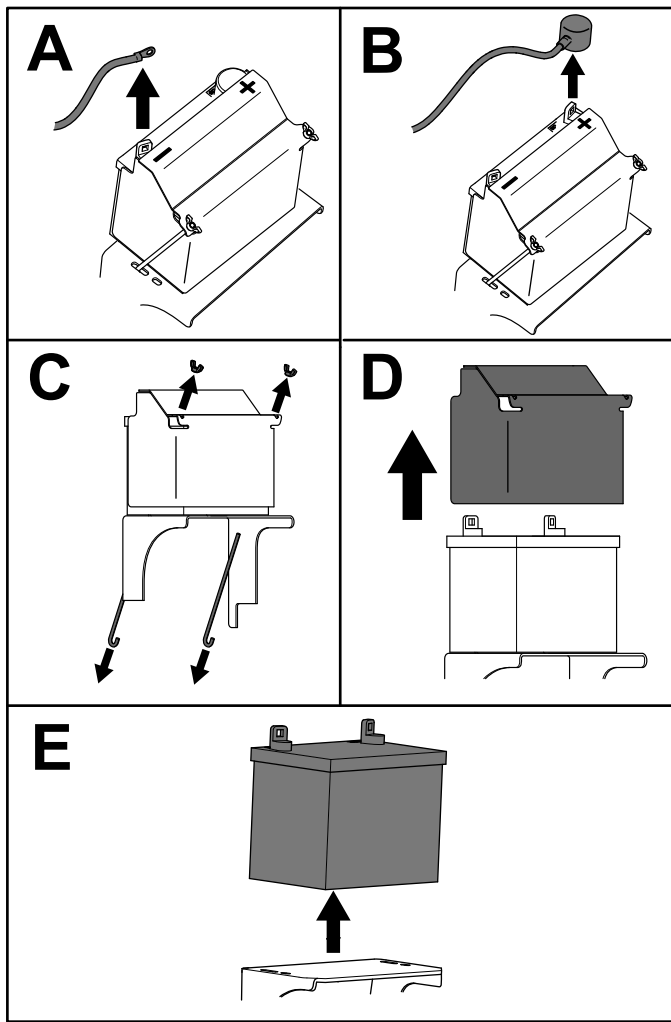

Figure 48

g273408

## Charging the Battery

### ⚠ WARNING

Charging the battery produces gasses that can explode.

Never smoke near the battery and keep sparks and flames away from battery.

**Important:** Always keep the battery fully charged (1.265 specific gravity) to prevent battery damage when the temperature is below 0°C (32°F).

1. Remove the battery from the chassis; refer to [Removing the Battery \(page 34\)](#).
2. Check the electrolyte level.
3. Ensure that the filler caps are installed on the battery.
4. Charge the battery for 1 hour at 25 to 30 A or 6 hours at 4 to 6 A.
5. When the battery is fully charged, unplug the charger from the electrical outlet, and disconnect the charger leads from the battery posts ([Figure 49](#)).
6. Install the battery onto the machine and connect the battery cables; refer to [Installing the Battery \(page 36\)](#).

**Note:** Do not run the machine with the battery disconnected; electrical damage may occur.

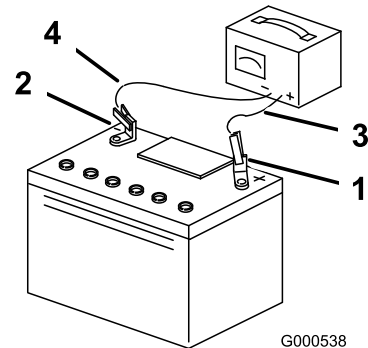

G000538

g000538

Figure 49

- |                          |                           |
|--------------------------|---------------------------|
| 1. Positive battery post | 3. Red (+) charger lead   |
| 2. Negative battery post | 4. Black (-) charger lead |

## Installing the Battery

Install the battery as shown in [Figure 50](#).

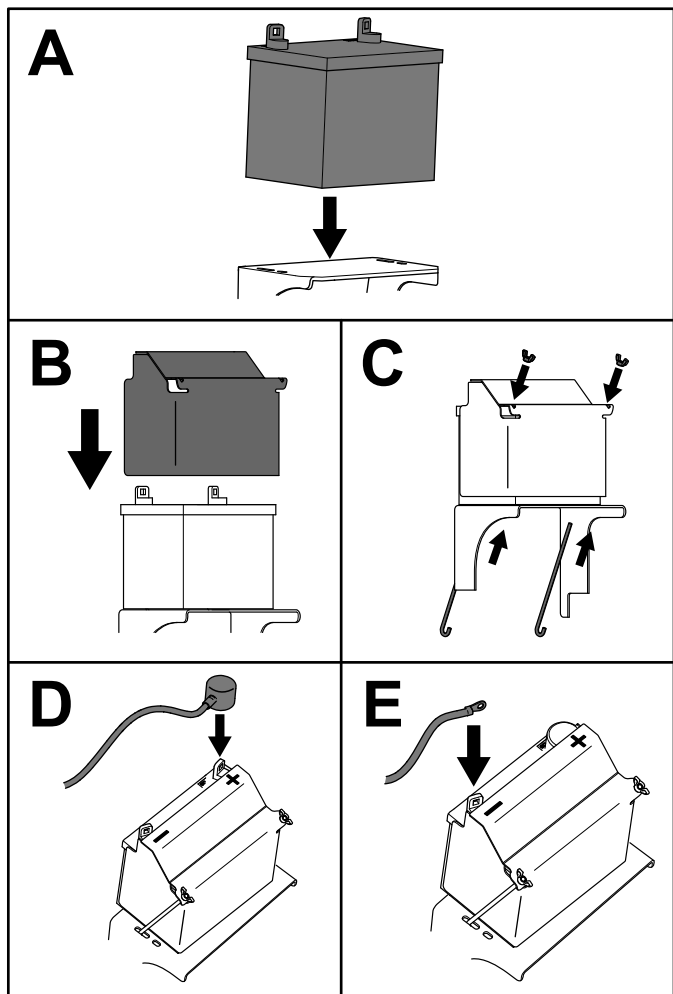

Figure 50

g273407

## Servicing the Fuses

The electrical system is protected by fuses. It requires no maintenance. If a fuse blows, check the component or circuit for a malfunction or short.

1. Park the machine on a level surface, disengage the PTO, and engage the parking brake.
2. Shut off the engine, remove the key, and wait for all moving parts to stop before leaving the operating position.
3. Release the operator cushion from the rear of the machine.
4. Pull out the fuse and replace it ([Figure 51](#)).
5. Install the operator cushion.

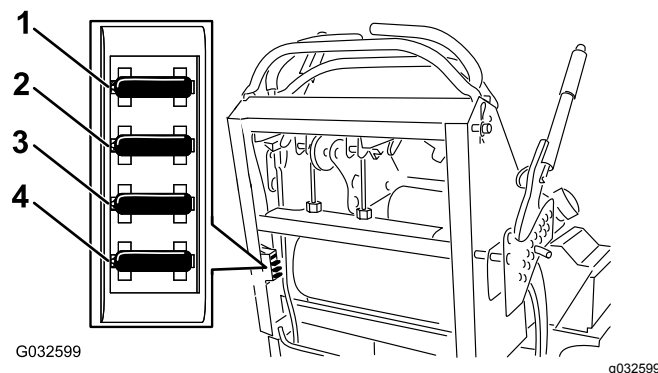

Figure 51

1. Optional accessory fuse (15 A)
2. Power-takeoff (PTO) fuse (10 A)
3. Charge fuse (25 A)
4. Main fuse (30 A)

# Drive System Maintenance

## Adjusting the Tracking

If you push both motion-control levers forward the same distance and the machine pulls to 1 side, adjust the tracking as follows.

1. Park the machine on a level surface, disengage the PTO, and engage the parking brake.
2. Shut off the engine, remove the key, and wait for all moving parts to stop before leaving the operating position.
3. Release the cushion from the rear of the machine.
4. Rotate the right cable adjustment to position the right motion-control lever in the center of the control-panel neutral-lock slot (Figure 53).

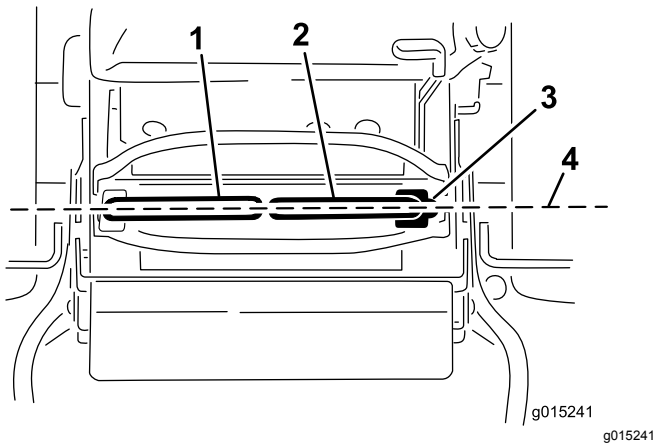

Figure 52

1. Left motion-control lever
2. Right motion-control lever
3. NEUTRAL-LOCK position
4. Align the control levers front to back.

5. Rotate the left cable adjustment to match the left wheel speed to the previously set right wheel speed.
6. Adjust in quarter-turn increments until the machine tracks straight.

**Note:** Adjust only the left cable to match the left wheel speed to the right wheel speed. Do not adjust the right wheel speed as this positions the right motion-control lever out of the center for the control-panel neutral-lock slot.

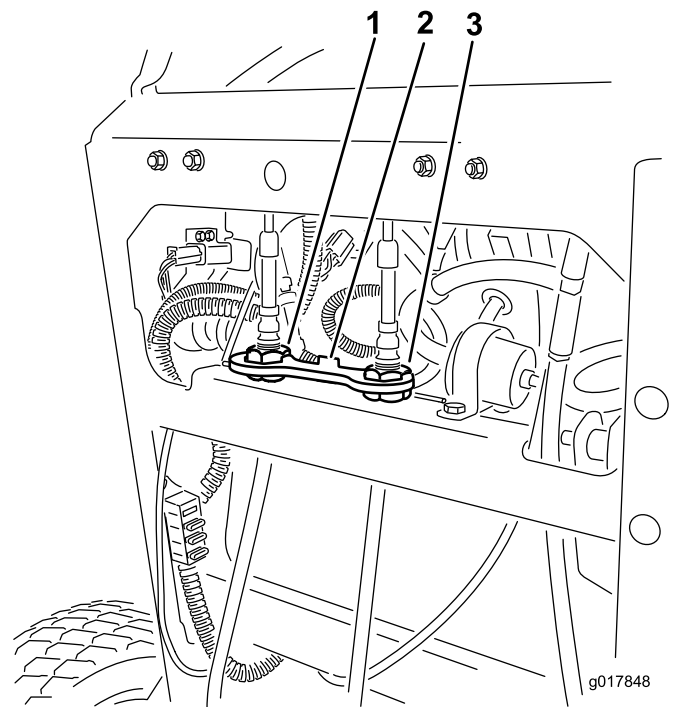

Figure 53

1. Left cable adjustment
2. Cable lock
3. Right cable adjustment

7. Check for proper tracking.

**Note:** If the machine does not start after adjusting the tracking, make sure that the proximity switch target aligns with the bolt attached to the motion-control lever; refer to [Adjusting the Proximity Switch \(page 37\)](#).

8. Repeat the cable adjustment until the tracking is correct.
9. Check that the machine does not creep from neutral with the park brakes disengaged.

**Important:** Do not rotate the linkage too far, as this may cause the machine to creep in neutral.

## Adjusting the Proximity Switch

Use this procedure if the machine does not start after adjusting the tracking.

1. Ensure that the bolt attached to the motion-control lever aligns with the proximity-switch target (Figure 54).
2. If needed, loosen the bolts and adjust the proximity switch until the target aligns with the bolt attached to the motion-control lever (Figure 54).

3. Check the distance of the bolt to the proximity switch; it needs to be between 0.51 to 1.02 mm (0.02 to 0.04 inches) as shown in [Figure 54](#).
4. If adjustment is needed, loosen the jam nut and adjust the bolt to the correct distance.
5. Tighten the jam nut after adjusting the bolt ([Figure 54](#)).
6. Test the safety-interlock system before operating the machine.

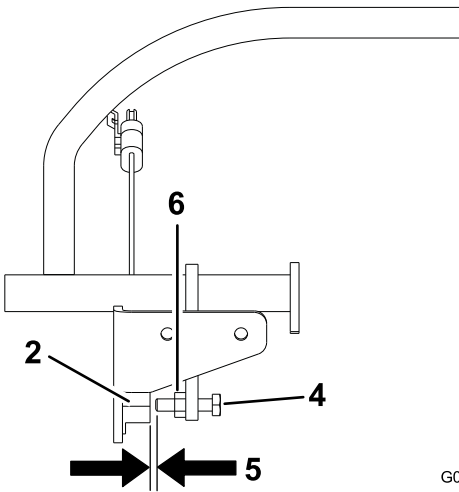
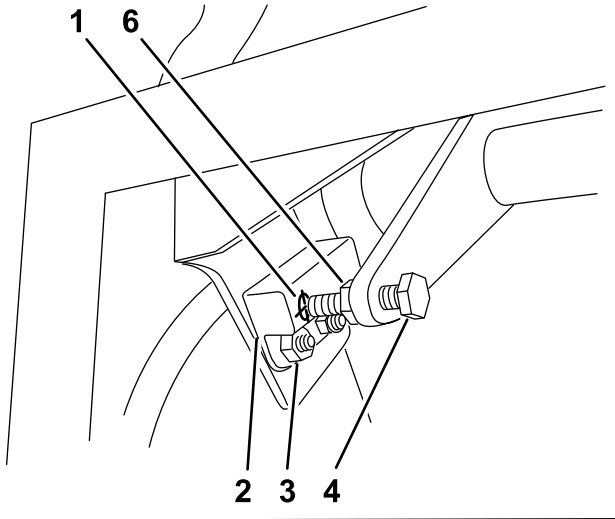

**Figure 54**

- |                            |  |
|----------------------------|--|
| 1. Proximity-switch target | 4. Bolt attached to the motion-control lever |
| 2. Proximity switch        | 5. 0.51 to 1.02 mm (0.02 to 0.04 inches)     |
| 3. Bolts and nuts          | 6. Jam nut                                   |

## Checking the Tire Pressure

**Service Interval:** Every 50 hours/Monthly (whichever comes first)

Maintain the air pressure in the rear tires at 83 to 97 kPa (12 to 14 psi).

**Important:** Uneven tire pressure can cause an uneven cut.

**Note:** The front tires are semi-pneumatic tires and do not require air-pressure maintenance.

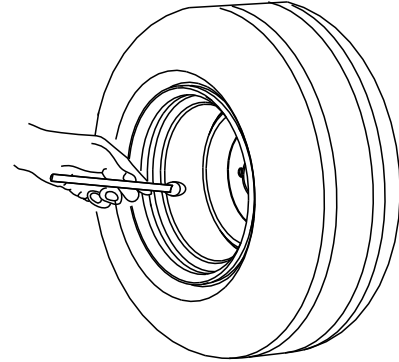

G001055

**Figure 55**

g001055

# Adjusting the Caster-Pivot Bearing

**Service Interval:** Every 500 hours/Yearly (whichever comes first)

1. Park the machine on a level surface, disengage the PTO, and engage the parking brake.
2. Shut off the engine, remove the key, and wait for all moving parts to stop before leaving the operating position.
3. Remove the dust cap from the caster and tighten the locknut (Figure 56).
4. Tighten the locknut until the spring washers are flat, and then back off 1/4 turn to properly set the preload on the bearings (Figure 56).

**Important:** Make sure that the spring washers are installed correctly as shown in Figure 56.

5. Install the dust cap (Figure 56).

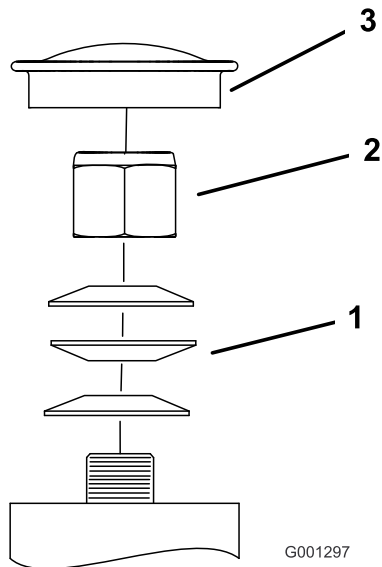

**Figure 56**

- |                   |             |
|-------------------|-------------|
| 1. Spring washers | 3. Dust cap |
| 2. Locknut        |             |

# Adjusting the Electric Clutch

**Service Interval:** Every 100 hours—Check the electric clutch.

The clutch is adjustable to ensure proper engagement and proper braking.

1. Park the machine on a level surface, disengage the PTO, and engage the parking brake.
2. Shut off the engine, remove the key, and wait for all moving parts to stop before leaving the operating position.
3. Insert a 0.4 to 0.5 mm (0.01 to 0.02 inch) feeler gauge through an inspection slot in the side of the assembly.

**Note:** Ensure that it is between the armature and the rotor friction surfaces.

**Note:** The gap needs to be at least 0.4 mm (0.02 inches) and not more than 0.5 mm (0.02 inches).

4. If adjustment is needed, use a 0.4 mm (0.02 inches) feeler gauge to set each of the 3 adjustment-slot positions.
5. Tighten the locknuts until there is slight binding on the feeler gauge but it can be moved easily within the air gap (Figure 57).
6. Repeat this for the remaining slots.
7. Check each slot again and make slight adjustments until the feeler gauge is between the rotor and armature with very slight contact between them.

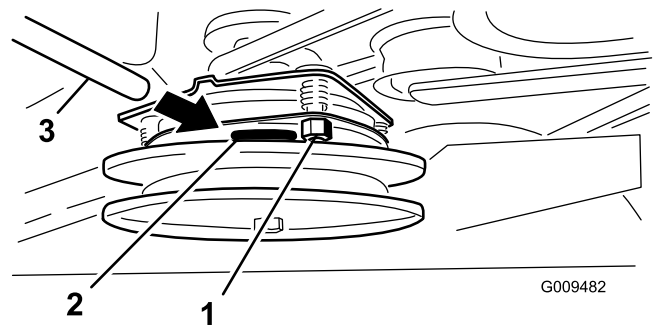

**Figure 57**

- |                  |                 |
|------------------|-----------------|
| 1. Adjusting nut | 3. Feeler gauge |
| 2. Slot          |                 |

# Cooling System Maintenance

## Cleaning the Air-Intake Screen

**Service Interval:** Before each use or daily

Before each use, remove any buildup of grass, dirt, or other debris from the cylinder and cylinder-head cooling fins, air-intake screen on the flywheel end, and the carburetor-governor levers and linkage. This helps ensure adequate cooling of the engine and the correct engine speed, and it reduces the possibility of overheating or mechanical damage to the engine.

## Cleaning the Cooling System

**Service Interval:** Every 100 hours—Check and clean engine cooling fins and shrouds (more often in dirty or dusty conditions).

1. Park the machine on a level surface, disengage the PTO, and engage the parking brake.
2. Shut off the engine, remove the key, and wait for all moving parts to stop before leaving the operating position.
3. Remove the air-intake screen and the fan housing (Figure 58).
4. Clean the debris and grass from the engine parts.
5. Install the air-intake screen and fan housing (Figure 58).

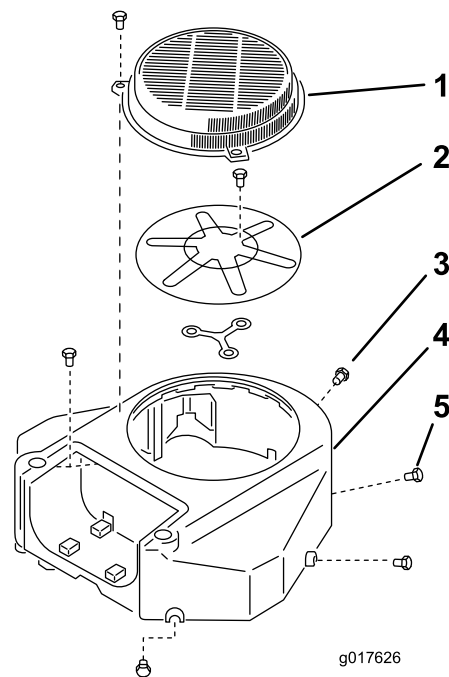

**Figure 58**

- |                             |                |
|-----------------------------|----------------|
| 1. Guard                    | 4. Fan housing |
| 2. Engine air-intake screen | 5. Screw       |
| 3. Bolt                     |                |



# Brake Maintenance

## Testing the Parking Brake

**Service Interval:** Before each use or daily

Before each use, test the parking brake on both a level surface and slope.

Always engage the parking brake when you stop the machine or leave it unattended. If the parking brake does not hold securely, adjust it.

1. Disengage the PTO and engage the parking brake
2. Shut off the engine, remove the key, and wait for all moving parts to stop before leaving the operating position.
3. Disengage the parking brake.
4. Engage the brake lever and ensure that the machine does not move.
5. Adjust the brake if needed.

## Checking the Brake Clearance

**Service Interval:** Before each use or daily

**Important:** Ensure that the machine is on a level surface when checking and adjusting the brake.

1. Park the machine on a level surface, disengage the PTO, and engage the parking brake.
2. Shut off the engine, remove the key, and wait for all moving parts to stop before leaving the operating position.
3. Check the tire pressure; refer to [Checking the Tire Pressure \(page 38\)](#).
4. Disengage the parking brake; refer to [Operating the Parking Brake \(page 13\)](#).
5. With the brake disengaged, measure the distance between the brake bar and the tire on each side.
6. Using the side with the smallest clearance, ensure that the distance is between 3 and 6 mm (1/8 and 1/4 inches) as shown in [Figure 59](#); refer to [Adjusting the Brakes \(page 42\)](#) if the distance is incorrect.

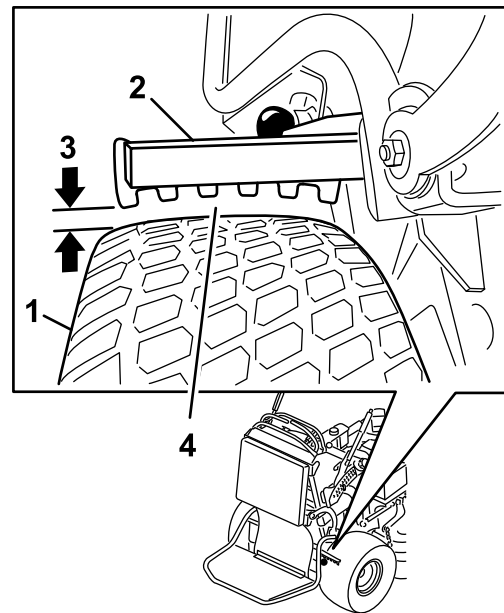

**Figure 59**

g277633

1. Tire
2. Brake bar
3. Clearance between 3 and 6 mm (1/8 and 1/4 inches)
4. Measure the smallest clearance between the bar and tire.

# Adjusting the Brakes

1. Park the machine on a level surface, disengage the PTO, and engage the parking brake.
2. Shut off the engine, remove the key, and wait for all moving parts to stop before leaving the operating position.
3. Disengage the parking brake.
4. To adjust the brake, remove the clevis pin and hairpin cotter from the lower-brake lever and yoke (Figure 60).
5. Adjust the yoke (Figure 59).

**Note:** The distance between the brake bar and the tire needs to be between 3 and 6 mm (1/8 and 1/4 inches).

**Note:** To tighten the brake, rotate the yoke up. To loosen the brake, rotate the yoke down.

6. Check the brake operation again; refer to [Testing the Parking Brake](#) (page 41).
7. Secure the yoke to the lower-brake lever with the clevis pin and hairpin cotter (Figure 60).

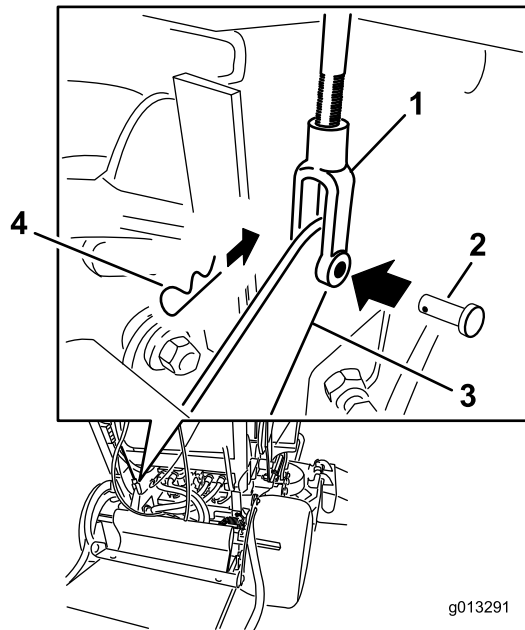

**Figure 60**

- |               |                      |
|---------------|----------------------|
| 1. Yoke       | 3. Lower-brake lever |
| 2. Clevis pin | 4. Hairpin cotter    |

# Belt Maintenance

## Checking the Belts

**Service Interval:** Every 100 hours—Check the mower-deck belt(s).

Check belts for cracks, frayed edges, burn marks, wear, signs of overheating, or any other damage.

The signs of a worn mower belt are squealing while the belt is rotating, blades slipping while you are cutting grass, frayed belt edges, burn marks, and cracks. Replace the mower belt if you detect any of these signs.

## Replacing the Mower-Deck Belt

**Important:** The fasteners on the covers of this machine are designed to remain on the cover after removal. Loosen all of the fasteners on each cover a few turns so that the cover is loose but still attached, then go back and loosen them until the cover comes free. This prevents you from accidentally stripping the bolts free of the retainers.

1. Park the machine on a level surface, disengage the PTO, and engage the parking brake.
2. Shut off the engine, remove the key, and wait for all moving parts to stop before leaving the operating position.
3. Remove the belt covers and deck guards; refer to [Removing the Belt Covers](#) (page 26) and [Removing the Deck Guards](#) (page 26).
4. Remove the spring from the anchor post on the idler-pulley arm (Figure 61).

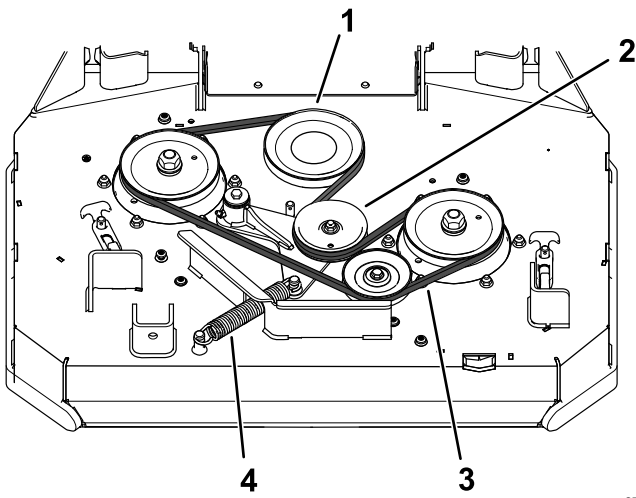

**Figure 61**

g277791

1. Clutch pulley
2. Spring-loaded idler pulley
3. Belt
4. Spring

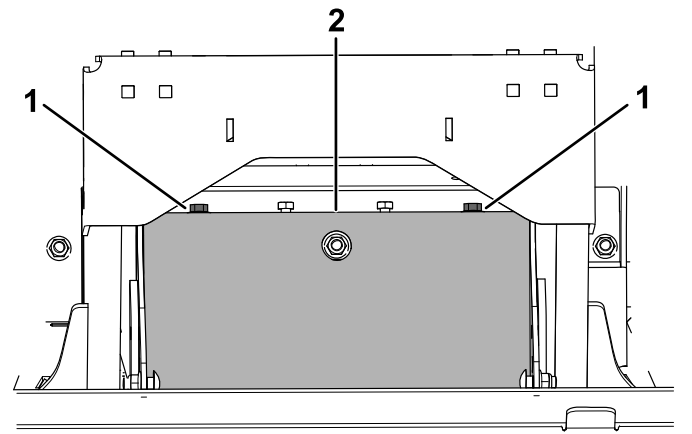

g279094

**Figure 62**

1. Bolt and washer
2. Pump-drive belt shield

5. Remove the worn mower belt ([Figure 61](#)).
6. Install the new mower belt around the clutch pulley, the deck pulleys, and the idler pulley ([Figure 61](#)).
7. Install the spring onto the anchor post on the idler-pulley arm ([Figure 61](#)).
8. Install the guards and belt covers; refer to [Removing the Deck Guards \(page 26\)](#) and [Removing the Belt Covers \(page 26\)](#).

6. Remove the shoulder bolt, the nut, and the washer from the engine deck and connected spring ([Figure 63](#)).

## Replacing the Pump-Drive Belt

**Service Interval:** Every 100 hours—Check the pump-drive belt.

1. Park the machine on a level surface, disengage the PTO, and engage the parking brake.
2. Shut off the engine, remove the key, and wait for all moving parts to stop before leaving the operating position.
3. Remove the mower-deck belt; refer to [Replacing the Mower-Deck Belt \(page 42\)](#).
4. Tilt the machine; refer to [Raising the Mower for Access \(page 24\)](#).
5. Remove the 2 bolts and 2 washers securing pump-drive belt shield ([Figure 62](#)). Remove the shield.

# Controls System Maintenance

## Adjusting the Right Motion-Control Lever

If the motion-control levers do not align horizontally, adjust the right motion-control lever.

**Note:** Adjust the horizontal alignment before adjusting the front to back alignment.

1. Park the machine on a level surface, disengage the PTO, and engage the parking brake.
2. Shut off the engine, remove the key, and wait for all moving parts to stop before leaving the operating position.
3. Push the right motion-control lever down out of the NEUTRAL-LOCK position (Figure 64).
4. Check if the right motion-control lever aligns horizontally with the left motion-control lever (Figure 64).

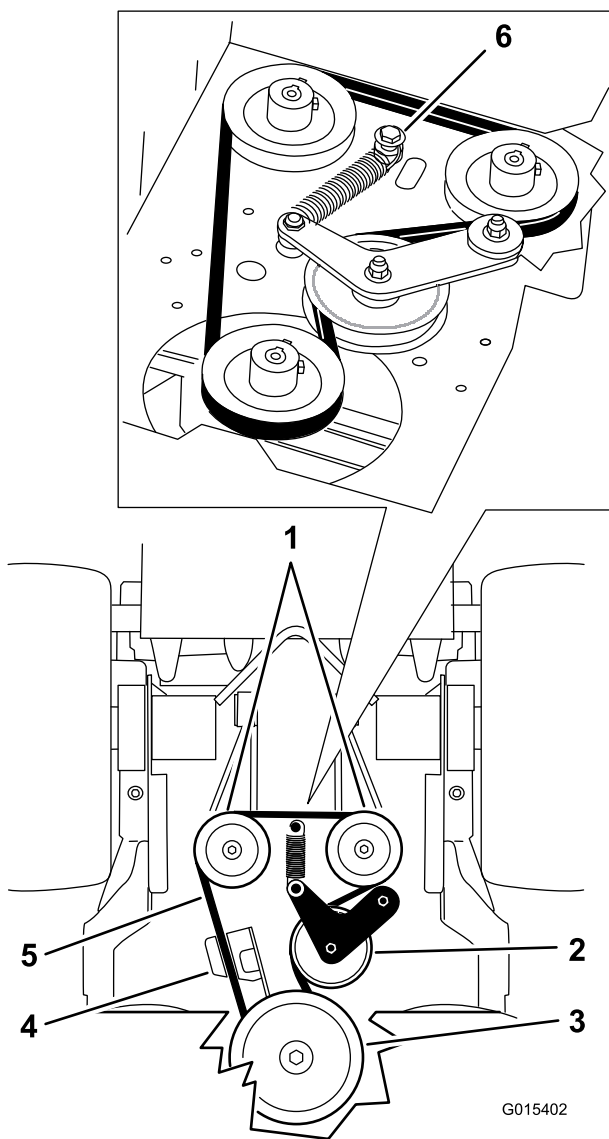

**Figure 63**

- |                    |                                   |
|--------------------|-----------------------------------|
| 1. Hydraulic pumps | 4. Clutch retainer                |
| 2. Idler pulley    | 5. Pump-drive belt                |
| 3. Clutch pulley   | 6. Shoulder bolt, nut, and washer |

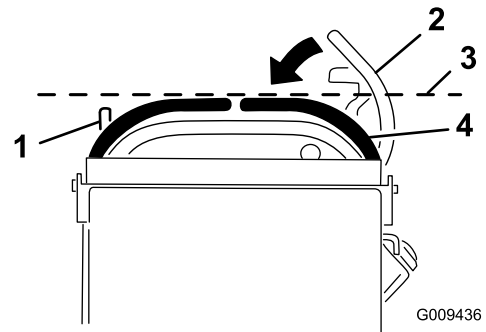

**Figure 64**

- |                               |  |
|-------------------------------|--|
| 1. Left motion-control lever  | 3. Check the horizontal alignment here.                    |
| 2. Right motion-control lever | 4. Right motion-control lever in the NEUTRAL-LOCK position |

**Note:** To adjust the right motion-control lever horizontally, adjust the cam.

7. Remove the pump-drive belt (Figure 63).
8. Install the new belt around the clutch and the 2 pump pulleys.
9. Install the spring onto the shoulder bolt and washer, and connect it to the engine deck with the nut (Figure 63).
10. Install the pump-drive belt shield using the 2 bolts and 2 washers removed previously.
11. Lower the machine to the operating position.
12. Install the mower-deck belt; refer to [Replacing the Mower-Deck Belt](#) (page 42).

5. Release the cushion from the rear of the machine.
6. Loosen the nut holding the cam (Figure 65).

# Adjusting the Neutral Position for the Motion-Control Levers

**Important:** Ensure that the tracking is correct after adjusting the motion-control levers (Figure 66).

**Note:** Adjust the horizontal alignment before adjusting the front to back alignment.

If the motion-control levers do not align front to back or the right control lever does not move easily into the NEUTRAL-LOCK position, adjust the neutral position for the levers.

1. After you finish the horizontal alignment, check the front-to-back alignment by slightly pushing the motion-control levers forward to take up any slack in the linkage for the control levers (Figure 66).

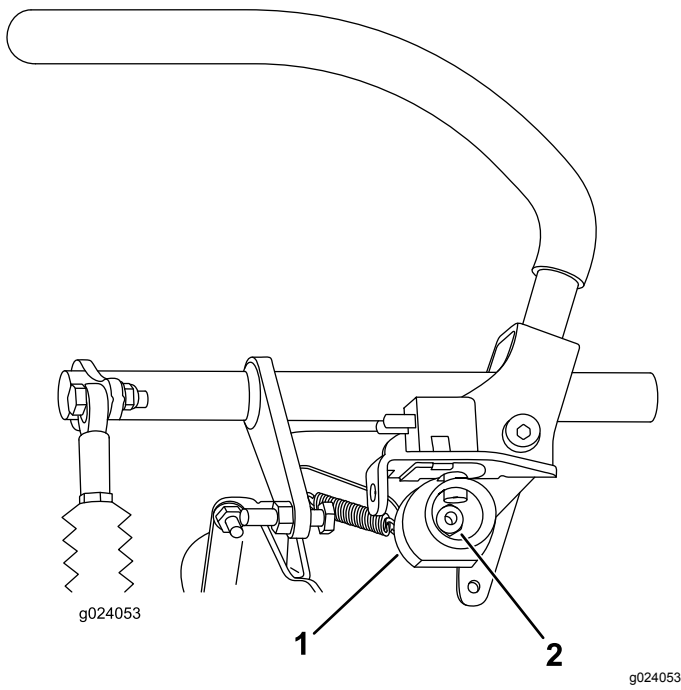

Figure 65

- |        |        |
|--------|--------|
| 1. Cam | 2. Nut |
|--------|--------|

7. Adjust the cam until it aligns with the left motion-control lever and tighten the nut for the cam.

**Note:** Moving the cam clockwise (in the vertical position) lowers the handle, while moving it counterclockwise (in the vertical position) raises the handle.

**Important:** Ensure that the flat portion of the cam does not go above a vertical position (right or left); otherwise you may damage the switch.

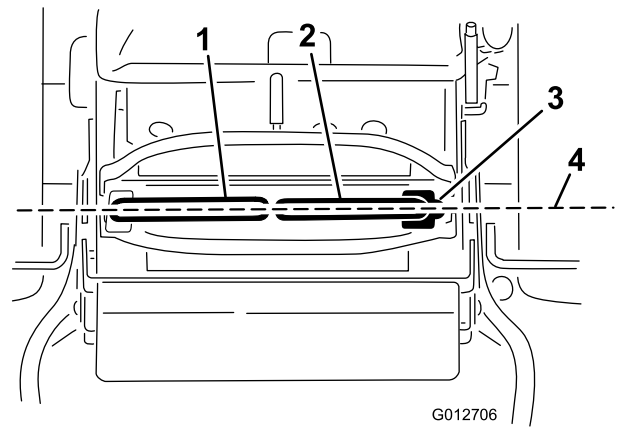

Figure 66

- |                               |   |
|-------------------------------|---|
| 1. Left motion-control lever  | 3. NEUTRAL-LOCK position                          |
| 2. Right motion-control lever | 4. Align the motion-control levers front to back. |

2. Ensure that the right motion-control lever moves easily into the NEUTRAL-LOCK position.

**Note:** Turn the cable adjustment clockwise to move the motion-control handle forward. Turn the cable adjustment counterclockwise to move the motion-control handle rearward.

3. Rotate the cable adjustment on the right side when adjustment is needed.

**Note:** Adjust the cable adjustment in quarter-turn increments.

4. After the right motion-control lever moves easily into the NEUTRAL-LOCK position, adjust the left motion-control lever to align it with the right motion-control lever.
5. Check for proper tracking; refer to [Adjusting the Tracking \(page 37\)](#).

6. Install the cable lock onto the cable-adjusting nuts to secure the adjustment (Figure 67).

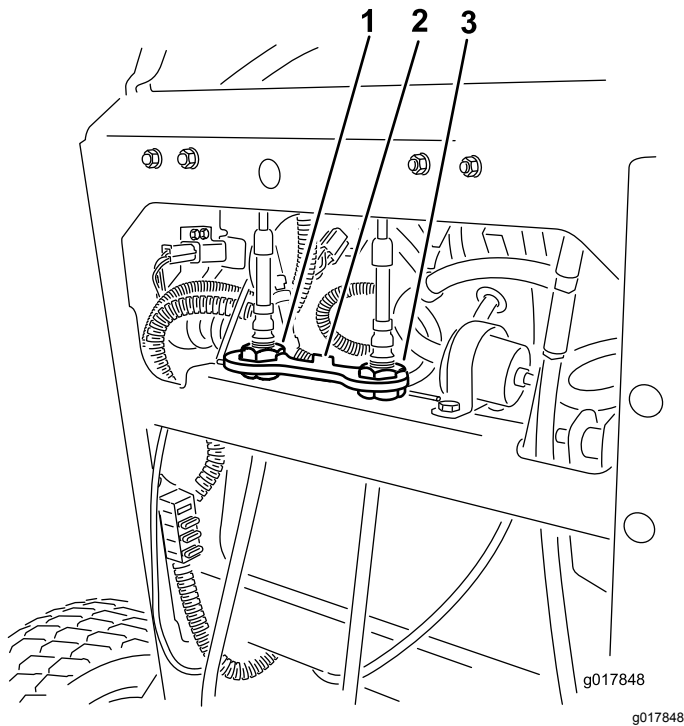

Figure 67

1. Left cable adjustment
2. Cable lock
3. Right cable adjustment

# Hydraulic System Maintenance

## Hydraulic System Safety

- Seek immediate medical attention if fluid is injected into skin. Injected fluid must be surgically removed within a few hours by a doctor.
- Ensure that all hydraulic-fluid hoses and lines are in good condition and all hydraulic connections and fittings are tight before applying pressure to the hydraulic system.
- Keep your body and hands away from pinhole leaks or nozzles that eject high-pressure hydraulic fluid.
- Use cardboard or paper to find hydraulic leaks.
- Safely relieve all pressure in the hydraulic system before performing any work on the hydraulic system.

## Hydraulic System Specifications

**Hydraulic Fluid Type:** Toro® HYPR-OIL™ 500 hydraulic fluid or Mobil® 1 15W-50 synthetic motor oil.

**Hydraulic System Fluid Capacity:** 2.0 L (67 fl oz)

**Important:** Use the fluid specified. Other fluids could damage the system.

## Checking the Hydraulic Fluid

**Service Interval:** After the first 8 hours

Every 50 hours

**Note:** The baffle inside the tank has 2 levels depending if the fluid is warm or cold.

1. Park the machine on a level surface, disengage the PTO, and engage the parking brake.
2. Shut off the engine, remove the key, and wait for all moving parts to stop before leaving the operating position.
3. Clean the area around the cap and the filler neck of the hydraulic tank (Figure 68).

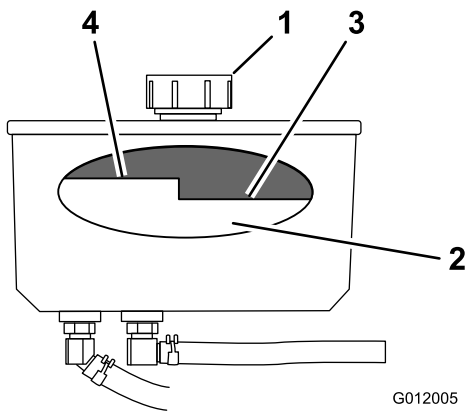

G012005

g012005

**Figure 68**

- |           |                          |
|-----------|--------------------------|
| 1. Cap    | 3. Cold fluid level—full |
| 2. Baffle | 4. Hot fluid level—full  |

4. Remove the cap from the filler neck (Figure 68).

**Note:** Look inside to check the fluid level in the reservoir.

5. Add fluid to the reservoir until it reaches the cold level of the baffle.
6. Run the machine at low idle for 15 minutes to allow any air to purge out of the system and to warm the fluid.
7. Shut off the engine, remove the key, and wait for all moving parts to stop before leaving the operating position.
8. Check the fluid level while the fluid is warm. If required, add fluid to the reservoir until it is between the hot level and the cold level.

**Note:** The fluid level should be below the hot level of the baffle when the fluid is warm (Figure 68).

9. Install the cap on the filler neck.

## Replacing the Hydraulic Fluid

**Service Interval:** Every 250 hours—Change the hydraulic fluid when using Mobil® 1 oil.

Every 500 hours—Change the hydraulic fluid when using Toro® HYPR-OIL™ 500 hydraulic fluid.

### ⚠ WARNING

Hot hydraulic fluid can cause severe burns.

Allow the hydraulic fluid to cool before performing any maintenance to the hydraulic system.

1. Park the machine on a level surface, disengage the PTO, and engage the parking brake.
2. Shut off the engine, remove the key, and wait for all moving parts to stop before leaving the operating position.
3. Remove hydraulic reservoir cap.
4. Locate the front hydraulic hose under the hydraulic tank and place a drain pan under the tank (Figure 69).
5. Loosen the hose clamp and move it down the hose.
6. Remove the front hydraulic hose and allow the fluid to run out of the tank.

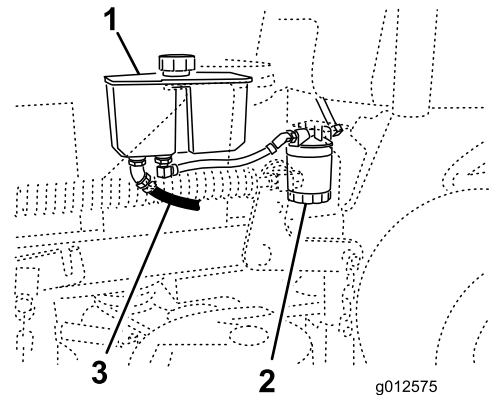

g012575

g012575

**Figure 69**

- |                     |                         |
|---------------------|-------------------------|
| 1. Hydraulic tank   | 3. Front hydraulic hose |
| 2. Hydraulic filter |                         |

7. Change the hydraulic filter; refer to [Replacing the Hydraulic Filter \(page 48\)](#).
8. Connect the hydraulic hose under the tank.
9. Add fluid to the tank until it reaches the cold baffle of the tank.

**Important:** Use the specified fluid or equivalent. Other fluids could cause system damage.

10. Install the hydraulic-tank cap.
11. Start engine and let run for about 2 minutes to purge air from the system.
12. Shut off the engine and check for leaks.
- Note:** If 1 or both wheels do not drive, refer to [Bleeding the Hydraulic System \(page 49\)](#).
13. Check the level of the fluid and add fluid, if required.

**Important:** Do not overfill.

# Replacing the Hydraulic Filter

**Service Interval:** After the first 8 hours

Every 500 hours/Yearly (whichever comes first)

## ⚠ WARNING

Hot hydraulic fluid can cause severe burns.

Allow the hydraulic fluid to cool before performing any maintenance to the hydraulic system.

1. Park the machine on a level surface, disengage the PTO, and engage the parking brake.
2. Shut off the engine, remove the key, and wait for all moving parts to stop before leaving the operating position.
3. Locate the filter and place a drain pan under the filter ([Figure 70](#)).

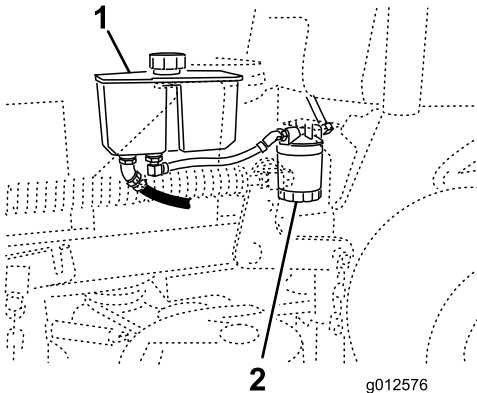

**Figure 70**

1. Hydraulic tank
2. Hydraulic filter

4. Remove the old filter and wipe the filter-adapter gasket surface clean ([Figure 71](#)).
5. Apply a thin coat of hydraulic fluid to the rubber gasket on the replacement filter.
6. Install replacement hydraulic filter onto the filter adapter.
7. Turn the filter clockwise until the rubber gasket contacts the filter adapter and tighten the filter an additional 1/2 turn ([Figure 71](#)).

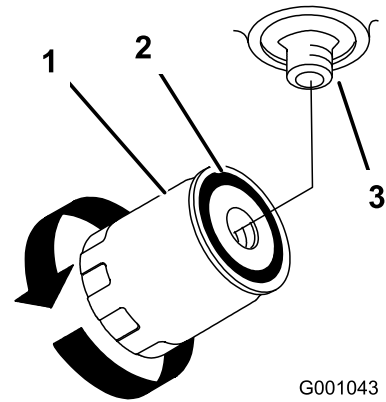

**Figure 71**

1. Hydraulic filter
2. Gasket
3. Adapter

8. Clean up any spilled fluid.
9. Check the fluid in the reservoir and add fluid to the tank until it reaches the cold baffle of the tank.
10. Start the engine and let it run for about 2 minutes to purge air from the system.
11. Shut off the engine and check for leaks.
12. Check the fluid level and add fluid, if required.

**Important:** Use the specified fluid or equivalent. Other fluids could cause system damage.

**Note:** If one or both wheels do not drive, refer to [Bleeding the Hydraulic System \(page 49\)](#).

**Important:** Do not overfill.



# Bleeding the Hydraulic System

The traction system is self-bleeding, however, it may be necessary to bleed the system if fluid is changed or after work is performed on the system.

1. Park the machine on a level surface, disengage the PTO, and engage the parking brake.
2. Shut off the engine, remove the key, and wait for all moving parts to stop before leaving the operating position.
3. Raise the rear of the machine onto jack stands high enough to raise the drive wheels off the ground.
4. Start the engine and move the throttle control to the idle position.

**Note:** If the drive wheel does not rotate, assist the purging of the system by carefully rotating the tire in the forward direction.

5. Check the hydraulic fluid level as it drops, and add fluid as required to maintain the proper level.
6. Repeat this procedure for the opposite wheel.

# Checking the Hydraulic Hoses

**Service Interval:** Every 100 hours

Check the hydraulic hoses for leaks, loose fittings, kinks, loose mounting supports, wear, general weathering, and chemical deterioration. Make any necessary repairs before operating.

**Note:** Keep areas around the hydraulic system clean from grass and debris buildup.

**Note:** Extended operating time at high temperatures in a hot climate may lead to deterioration of hoses and seals. Inspect more frequently in a hot climate, and change the hydraulic fluid and filter more frequently.

# Mower Deck Maintenance

## Servicing the Cutting Blades

To ensure a superior quality of cut, keep the blades sharp. For convenient sharpening and replacement, keep extra blades on hand.

## Blade Safety

A worn or damaged blade can break, and a piece of the blade could be thrown toward you or bystanders, resulting in serious personal injury or death.

- Inspect the blades periodically for wear or damage.
- Use care when checking the blades. Wrap the blades or wear gloves, and use caution when servicing the blades. Only replace or sharpen the blades; never straighten or weld them.
- Always inspect the machine to ensure that the blades and blade bolts are not worn or damaged. Replace worn or damaged blades and bolts in sets to preserve balance.
- On multi-bladed machines, take care as rotating 1 blade can cause other blades to rotate.

## Before Inspecting or Servicing the Blades

1. Park the machine on a level surface, disengage the PTO, and engage the parking brake.
2. Shut off the engine, remove the key, and disconnect the spark-plug wires from the spark plugs.

## Inspecting the Blades

**Service Interval:** Before each use or daily

1. Inspect the cutting edges ([Figure 72](#)).
2. If the edges are not sharp or have nicks, remove and sharpen the blade; refer to [Sharpening the Blades \(page 50\)](#).
3. Inspect the blades, especially in the curved area.
4. If you notice any cracks, wear, or a slot forming in this area, immediately install a new blade ([Figure 72](#)).

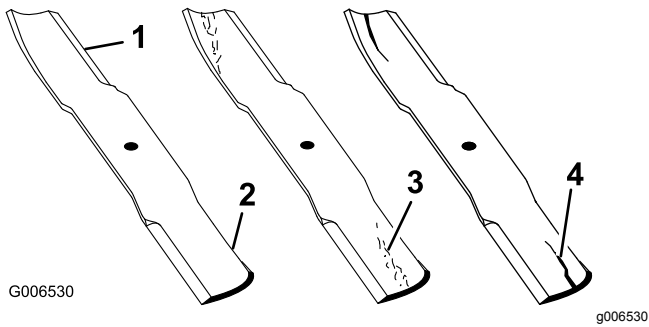

Figure 72

1. Cutting edge
2. Curved area
3. Wear/slot forming
4. Crack

## Checking for Bent Blades

1. Rotate the blades until the ends face forward and backward.
2. Measure from a level surface to the cutting edge, position **A**, of the blades (Figure 73).

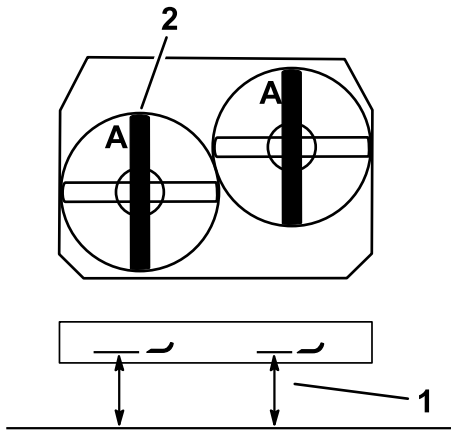

Figure 73

1. Measure here from blade to hard surface
2. Position A

3. Rotate the opposite ends of the blades forward.
4. Measure from a level surface to the cutting edge of the blades at the same position as in step 2 above.

**Note:** The difference between the dimensions obtained in steps 2 and 3 must not exceed 3 mm (1/8 inch).

**Note:** If this dimension exceeds 3 mm (1/8 inch), replace the blade.

## ⚠ WARNING

A blade that is bent or damaged could break apart and could critically injure you or bystanders.

- Always replace a bent or damaged blade with a new blade.
- Do not file or create sharp notches in the edges or surfaces of the blade.

## Removing the Blades

Replace the blade if it hits a solid object, is out of balance, or is bent. For best performance and continued safety conformance of the machine, use genuine Toro replacement blades. Replacement blades made by other manufacturers may result in non-conformance with safety standards.

1. Hold the blade end using a rag or thickly padded glove.
2. Remove the blade bolt, curved washer, and blade from the spindle shaft (Figure 74).

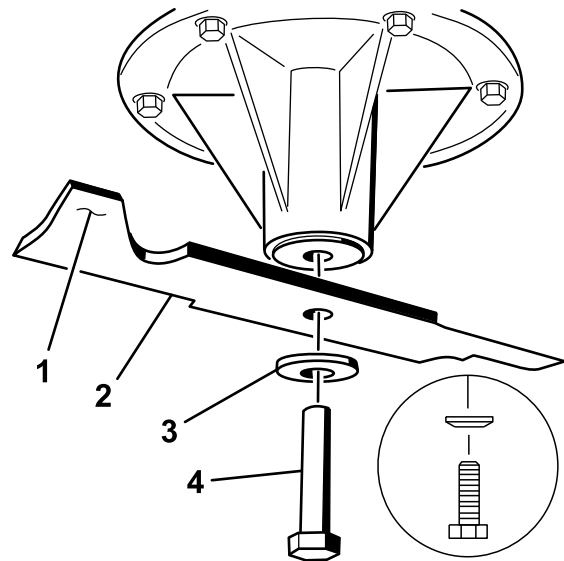

Figure 74

1. Sail area of the blade
2. Blade
3. Curved washer
4. Blade bolt

## Sharpening the Blades

1. Use a file to sharpen the cutting edge at both ends of the blade (Figure 75).

**Note:** Maintain the original angle.

**Note:** The blade retains its balance if the same amount of material is removed from both cutting edges.

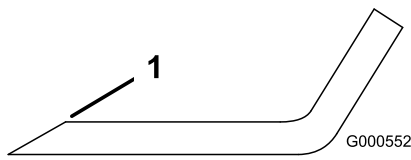

**Figure 75**

g000552

1. Sharpen at original angle.
2. Check the balance of the blade by putting it on a blade balancer (Figure 76).

**Note:** If the blade stays in a horizontal position, the blade is balanced and can be used.

**Note:** If the blade is not balanced, file some metal off the end of the sail area only (Figure 75).

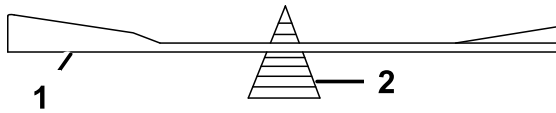

**Figure 76**

G000553

g000553

1. Blade
2. Balancer

3. Repeat this procedure until the blade is balanced.

## Installing the Blades

**Service Interval:** Yearly

1. Inspect the blade bolt for damaged threads. Replace the bolt and curved washer as necessary.
2. Install the blade onto the spindle shaft (Figure 77).

**Important:** The curved part of the blade must be pointing upward toward the inside of the deck to ensure proper cutting.

3. Install the curved washer and blade bolt (Figure 77).

**Note:** The curved washer cone must be installed toward the bolt head (Figure 77).

4. Torque the blade bolt to 115 to 150 N·m (85 to 110 ft·lb).

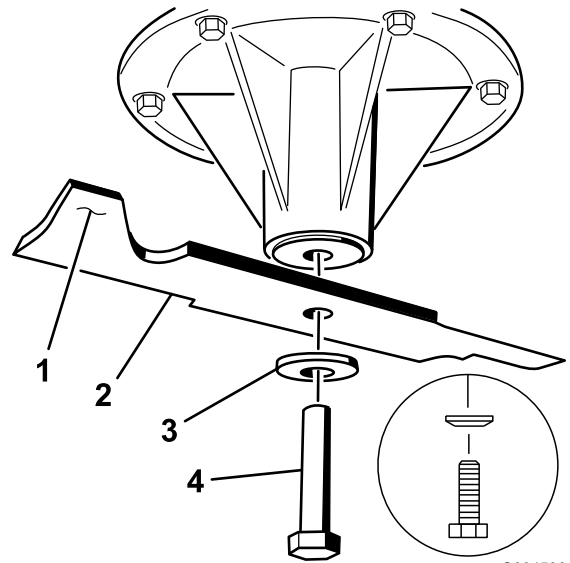

**Figure 77**

G004536

g004536

1. Sail area of the blade
2. Blade
3. Curved washer
4. Blade bolt

## Leveling the Mower Deck

### Preparing the Machine

Ensure that the mower deck is level any time you install the mower deck or when you see an uneven cut on your lawn.

Level the mower deck side to side before adjusting the front-to-rear slope.

1. Park the machine on a level surface, disengage the PTO, and engage the parking brake.
2. Shut off the engine, remove the key, and disconnect the spark-plug wires from the spark plugs.
3. Check the tire pressure of both drive tires; refer to [Checking the Tire Pressure \(page 38\)](#).
4. Check the mower deck for bent blades; remove and replace any bent blades; refer to [Servicing the Cutting Blades \(page 49\)](#).
5. Lower the mower deck to the 76 mm (3 inch) height-of-cut position.

### Checking the Swivel and Yoke Distances

1. Check the distance between the swivels, measuring at the center of the swivels (center-to-center length) on each threaded rod (Figure 78).

**Note:** Ensure that the length is 49.5 cm (19-1/2 inches) for 91 cm (36 inch) mower decks and

43.7 cm (17-3/16 inches) for 102 cm (40 inch) mower decks.

- Loosen the jam nuts at the **front** swivel (Figure 78).
- Using the jam nuts, adjust the length of the threaded rod to achieve the correct distance.
- Tighten the jam nuts at the **front** swivel (Figure 78).

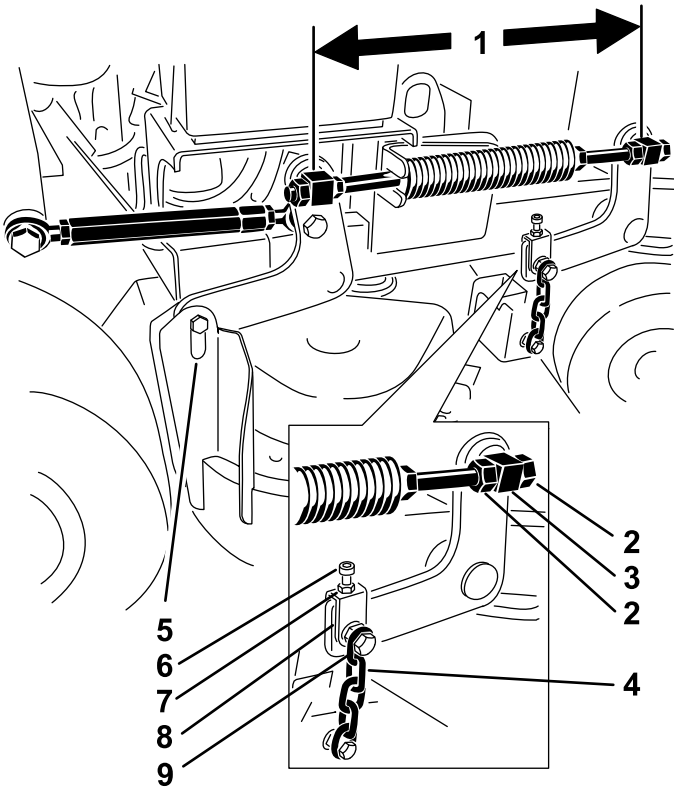

Figure 78

g277713

- Measure here at the center of the swivels (center-to-center length).
- Swivel jam nuts
- Front swivel
- Front chain
- Rear mount
- Adjustment bolt
- Jam nut
- Yoke
- Upper chain bolt

- Check the distance between the yoke and the deck hanger arm at each yoke.

**Note:** This distance needs to be 11 mm (7/16 inch) as shown in Figure 79.

- If adjustment is needed, loosen the upper chain bolt (Figure 79).
- Loosen the jam nut and adjust the adjustment bolt to achieve the correct distance as shown in Figure 79.
- Tighten the jam nut and the upper chain bolt.

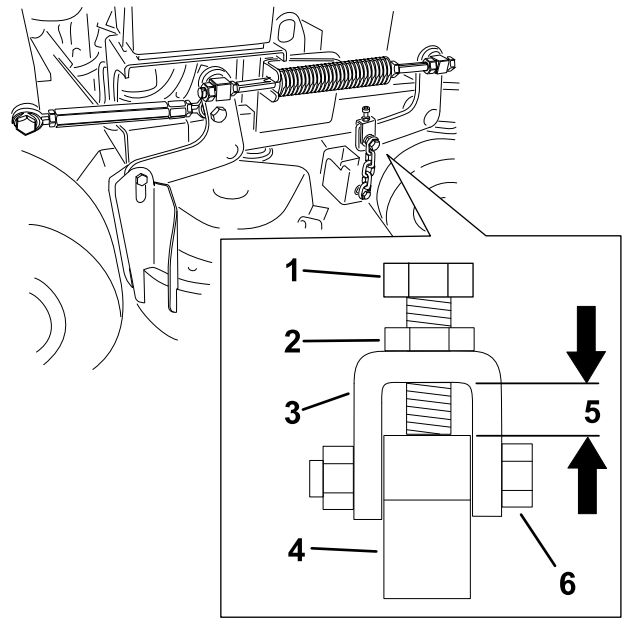

g277712

Figure 79

- Adjustment bolt
- Jam nut
- Yoke
- Deck hanger arm
- The distance needs to be 11 mm (7/16 inch).
- Upper chain bolt

## Adjusting the Right Side Front-to-Rear Mower Deck Pitch

- Position the right blade front-to-rear (Figure 80).
- Measure the right blade at the **C** location, from a level surface to the cutting edge of the blade tip, and record this measurement (Figure 80).
- Measure the right blade at the **D** location, from a level surface to the cutting edge of the blade tip, and record this measurement (Figure 80).

**Note:** The mower blade should be 6 to 10 mm (1/4 to 3/8 inch) lower at position **C** than at position **D** (Figure 80). If it is not correct, proceed to the following steps.

- Loosen the jam nuts at the right and left front swivels (Figure 78).
- Using the right jam nuts, adjust the length of the right threaded rod to achieve the 6 to 10 mm (1/4 to 3/8 inch) front-to-rear pitch.
- Tighten the jam nuts at the right and left front swivels (Figure 78).

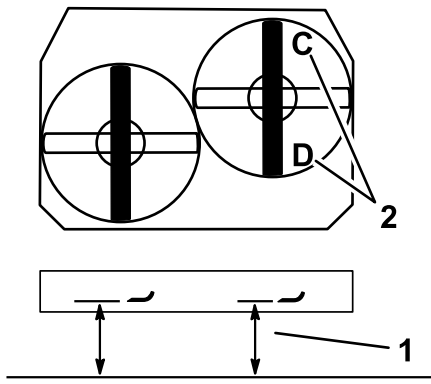

Figure 80

g277687

1. Measure here from the blade to the level surface.
2. Measure at C and D.

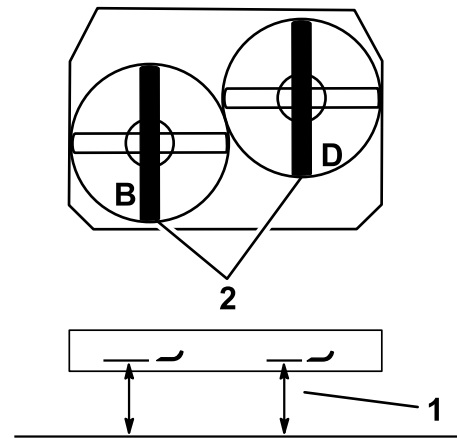

Figure 81

g277690

1. Measure here from the blade to the level surface.
2. Measure at B and D.

## Matching the Rear of the Mower Deck

1. Position the left and right blades front-to-rear.
2. Measure the left blade at the **B** location, from a level surface to the cutting edge of the blade tip, and record this measurement (Figure 81).
3. Measure the right blade at the **D** location, from a level surface to the cutting edge of the blade tip, and record this measurement (Figure 81).

**Note:** The measurement at position **B** needs to be within 3 mm (1/8 inch) of the measurement at position **D** (Figure 81). If it is not correct, proceed to the following steps.

4. Loosen the jam nuts at the left, front swivel (Figure 78).
5. Using the left jam nuts, adjust the length of the left hand threaded rod until location **B** matches location **D**.
6. Tighten the jam nuts at the left front swivel (Figure 78).

## Leveling the Front of the Mower Deck

1. Position the left and right blades front-to-rear.
2. Inspect the front chains and ensure that each chain has tension.

**Note:** If either chain is loose, adjust the threaded rod with the loose chain to achieve tension on that chain.

3. Measure the left blade at the **A** location, from a level surface to the cutting edge of the blade tip, and record this measurement (Figure 82).
4. Measure the right blade at the **C** location, from a level surface to the cutting edge of the blade tip, and record this measurement (Figure 82).

**Note:** The measurement between location **A** and **C** needs to be within 3 mm (1/8 inch). If it is not correct, proceed to the following steps.

5. Loosen the upper chain bolts (Figure 78).
6. Loosen the jam nuts on each yoke (Figure 78).
7. Adjust the adjustment bolts in the yokes, at locations **A** and **C**, to achieve the correct height (Figure 82).
8. Tighten the jam nuts and upper chain bolts (Figure 78).

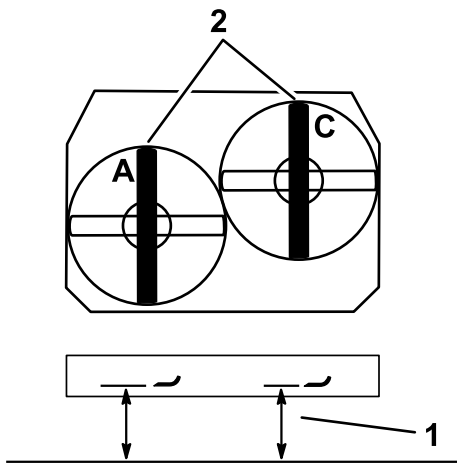

Figure 82

1. Measure here from the blade to the level surface.
2. Measure at A and C.

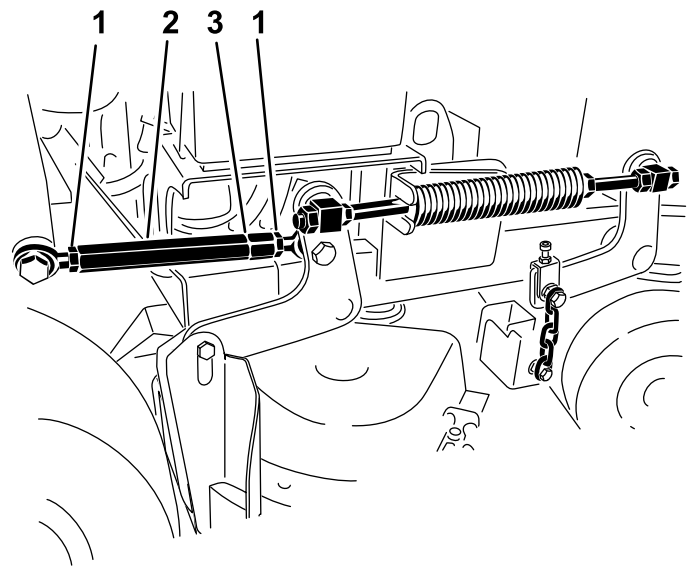

Figure 83

1. Jam nut
2. Turnbuckle
3. Groove indicating left threads

## Matching the Height of Cut

1. Lower the mower to the 76 mm (3 inch) height-of-cut position.
2. Position the right blade front-to-rear (Figure 80).
3. Measure the right blade at location C, from a level surface to the cutting edge of the blade tip, and record this measurement (Figure 82).

**Note:** The measurement at location C needs to be within an 3 mm (1/8 inch) of the 76 mm (3 inches) height-of-cut setting. If it is not correct, proceed to the following steps.

4. Loosen the jam nuts at both ends of the turnbuckle (Figure 83).

**Note:** The end of the turnbuckle with the groove has left threads (Figure 83).

5. Adjust the turnbuckle to raise or lower the deck height to achieve 76 mm (3 inches) at location C.
6. Tighten the jam nuts at both ends of the turnbuckle.
7. Check and ensure that the mower-deck lift lever latches into the transport position.

**Note:** If it does not latch into the transport position, adjust the turn buckle until it latches into the transport position.

8. Tighten the jam nuts.

## Adjusting the Compression Spring

**Note:** Adjusting the compression spring alters how much the deck floats and the amount of effort needed to lift the deck when using the height-of-cut lever.

- More spring compression reduces the lever lift force required and causes the deck to float more.
- Less spring compression increases the lever lift force required and causes the deck to float less.

1. Raise the height-of-cut lever and lock it into the transport position.
2. Check the length of the compression spring.

**Note:** Nominal length is 28.2 cm (11-1/8 inches) for 91 cm (36 inch) mower decks and 25.7 cm (10-1/8 inches) for 102 cm (40 inch) mower decks (Figure 84).

3. Adjust this distance by loosening the spring-jam nut and turning the nut in front of each spring (Figure 84).
4. Lock the nut into position by tightening the spring-jam nut (Figure 84).

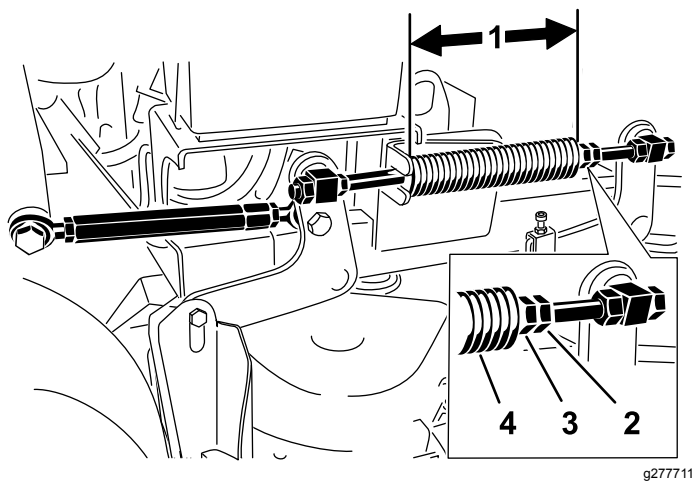

**Figure 84**

g277711

- |   |                       |
|---|-----------------------|
| 1. 25.7 cm (10-1/8 inch) for<br>102 cm (40 inch) mower<br>decks and 28.2 cm (11-1/8<br>inch) for 91 cm (36 inch)<br>mower decks | 3. Front nut          |
| 2. Spring jam nut   | 4. Compression spring |
- 
5. Repeat this procedure for the opposite deck-lift spring.

## Cleaning

### Cleaning under the Mower Deck

**Service Interval:** Before each use or daily

Remove the grass buildup under the mower daily.

1. Park the machine on a level surface, disengage the PTO, move the motion-control levers to the NEUTRAL-LOCK position, and engage the parking brake.
2. Shut off the engine, remove the key, and wait for all moving parts to stop before leaving the operating position.
3. Raise the front of the machine and use jack stands to support the mower.

### Cleaning the Rear Wheel Motors

**Service Interval:** Before each use or daily

1. Park the machine on a level surface, disengage the PTO, move the motion-control levers to the NEUTRAL-LOCK position, and engage the parking brake.
2. Shut off the engine, remove the key, and wait for all moving parts to stop before leaving the operating position.
3. Raise the operator's platform to access the rear wheel motors.

### Disposing of Waste

Engine oil, batteries, hydraulic fluid, and engine coolant are pollutants to the environment. Dispose of these according to your state and local regulations.

# Storage

## Storage Safety

- Let the engine cool before storing the machine.
- Do not store the machine or fuel near flames or drain the fuel indoors.

## Cleaning and Storage

**Service Interval:** Before storage

Before storage

1. Disengage the power takeoff (PTO), engage the parking brake, shut off the engine, and remove the key.
2. Remove grass clippings, dirt, and grime from the external parts of the entire machine, especially the engine.

***Important:* You can wash the machine with a mild detergent and water. Do not pressure-wash the machine. Avoid excessive use of water, especially near the drive system and engine. Pressure-washing can force dirt and water into critical parts, such as spindle bearings and electrical switches.**

3. Clean any dirt and chaff from the outside of the engine cylinder-head fins and blower housing.
4. Check the brake; refer to [Testing the Parking Brake \(page 41\)](#).
5. Service the air cleaner; refer to [Servicing the Air Cleaner \(page 29\)](#).
6. Grease the machine; refer to [Lubrication \(page 27\)](#).
7. Change the engine oil; refer to [Servicing the Engine Oil \(page 30\)](#).
8. Check the tire pressure; refer to [Checking the Tire Pressure \(page 38\)](#).
9. For long-term storage, do the following:
  - A. Add fuel stabilizer/conditioner to the fuel in the tank as directed by the fuel stabilizer manufacturer.
  - B. Run the engine to distribute the conditioned fuel through the fuel system for 5 minutes.
  - C. Shut off the engine, allow it to cool, and drain the fuel tank; refer to [Draining the Fuel Tank \(page 33\)](#), or operate the engine until it shuts off.
  - D. Start the engine and allow it to run until it shuts off. Repeat with the choke engaged (if applicable) until the engine does not start.

- E. Dispose of fuel properly; recycle it according to local regulations.

***Important:* Do not store fuel containing stabilizer/conditioner longer than the duration recommended by the fuel-stabilizer manufacturer.**

10. Remove the spark plug(s) and check its condition; refer to [Servicing the Spark Plug \(page 32\)](#).
11. With the spark plug(s) removed from the engine, pour 15 ml (2 tablespoons) of engine oil into the spark-plug hole, and use the starter to crank the engine and distribute the oil inside the cylinder.
12. Install the spark plug(s) but do not connect the wire to the spark plug(s).
13. Check and tighten all fasteners. Repair or replace any part that is damaged or missing.
14. Paint all scratched or bare metal surfaces with paint from an Authorized Service Dealer.
15. Store the machine in a clean, dry, garage or storage area. Remove the key from the switch and store it in a memorable place. Cover the machine to protect it and keep it clean.



# Troubleshooting

Problem	Possible Cause	Corrective Action
The engine does not start, starts hard, or fails to keep running.	<ol style="list-style-type: none"> <li>1. The fuel tank is empty or the shutoff valve is closed.</li> <li>2. The choke control is not engaged.</li> <li>3. A spark-plug wire is loose or disconnected.</li> <li>4. A spark plug is pitted, fouled, or the gap is incorrect.</li> <li>5. The air cleaner is dirty.</li> <li>6. Dirt is in the fuel filter.</li> <li>7. Dirt, water, or stale fuel is in the fuel system.</li> <li>8. The gap between the safety-interlock switches is not correct.</li> </ol>	<ol style="list-style-type: none"> <li>1. Fill the fuel tank with fuel and open the valve</li> <li>2. Engage the choke control.</li> <li>3. Install the wire on spark plug.</li> <li>4. Install a new, correctly gapped spark plug.</li> <li>5. Service the air-cleaner element.</li> <li>6. Replace the fuel filter.</li> <li>7. Contact an Authorized Service Dealer.</li> <li>8. Contact an Authorized Service Dealer.</li> </ol>
The engine loses power.	<ol style="list-style-type: none"> <li>1. The engine load is excessive.</li> <li>2. The air cleaner is dirty.</li> <li>3. The oil level in the crankcase is low.</li> <li>4. The cooling fins and air passages under the engine blower housing are plugged.</li> <li>5. A spark plug is pitted, fouled, or the gap is incorrect.</li> <li>6. The vent hole in the fuel cap is plugged.</li> <li>7. Dirt is in the fuel filter.</li> <li>8. Dirt, water, or stale fuel is in the fuel system.</li> </ol>	<ol style="list-style-type: none"> <li>1. Reduce the ground speed.</li> <li>2. Service the air-cleaner element.</li> <li>3. Add oil to the crankcase.</li> <li>4. Remove the obstruction from the cooling fins and air passages.</li> <li>5. Install a new, correctly gapped spark plug.</li> <li>6. Clean or replace the fuel cap.</li> <li>7. Replace the fuel filter.</li> <li>8. Contact an Authorized Service Dealer.</li> </ol>
The engine overheats.	<ol style="list-style-type: none"> <li>1. The engine load is excessive.</li> <li>2. The oil level in the crankcase is low.</li> <li>3. The cooling fins and air passages under the engine blower housing are plugged.</li> </ol>	<ol style="list-style-type: none"> <li>1. Reduce the ground speed.</li> <li>2. Add oil to the crankcase.</li> <li>3. Remove the obstruction from the cooling fins and air passages.</li> </ol>
The machine does not drive.	<ol style="list-style-type: none"> <li>1. The hydraulic-fluid reservoir is low.</li> <li>2. Air is in the hydraulic system.</li> <li>3. A pump-drive belt slips.</li> <li>4. A pump-drive belt idler spring is missing.</li> <li>5. The pump-bypass valves are open.</li> </ol>	<ol style="list-style-type: none"> <li>1. Add hydraulic fluid to the reservoir.</li> <li>2. Bleed the air out the hydraulic system.</li> <li>3. Replace the pump-drive belt.</li> <li>4. Replace the pump-drive belt idler spring.</li> <li>5. Tighten the bypass valves. Torque to 12 to 15 N·m (9 to 11 ft-lb).</li> </ol>
There is abnormal vibration.	<ol style="list-style-type: none"> <li>1. Cutting blade(s) is/are bent or unbalanced.</li> <li>2. A blade-mounting bolt is loose.</li> <li>3. The engine-mounting bolts are loose.</li> <li>4. An engine pulley, idler pulley, or blade pulley is loose.</li> <li>5. An engine pulley is damaged.</li> <li>6. A blade spindle is bent.</li> </ol>	<ol style="list-style-type: none"> <li>1. Install new cutting blade(s).</li> <li>2. Tighten the blade-mounting bolt.</li> <li>3. Tighten the engine-mounting bolts.</li> <li>4. Tighten the appropriate pulley.</li> <li>5. Contact an Authorized Service Dealer.</li> <li>6. Contact an Authorized Service Dealer.</li> </ol>

Problem	Possible Cause	Corrective Action
The cutting height is uneven.	<ol style="list-style-type: none"> <li>1. Blade(s) are not sharp.</li> <li>2. Cutting blade(s) is/are bent.</li> <li>3. The mower deck is not level.</li> <li>4. The mower deck pitch is wrong.</li> <li>5. The underside of mower deck is dirty.</li> <li>6. The tire pressure is not correct.</li> <li>7. A blade spindle is bent.</li> </ol>	<ol style="list-style-type: none"> <li>1. Sharpen the blade(s).</li> <li>2. Install new cutting blade(s).</li> <li>3. Level the mower deck side-to-side position.</li> <li>4. Adjust the front-to-rear pitch.</li> <li>5. Clean the underside of the mower deck.</li> <li>6. Adjust the tire pressure.</li> <li>7. Contact an Authorized Service Dealer.</li> </ol>
The blades do not rotate.	<ol style="list-style-type: none"> <li>1. A pump-drive belt is worn, loose or broken.</li> <li>2. A pump-drive belt is off pulley.</li> <li>3. A mower-deck belt is worn, loose or broken.</li> <li>4. A mower-deck belt is off the pulley.</li> <li>5. An idler spring is broken or missing.</li> <li>6. The electric clutch is out of adjustment.</li> <li>7. The clutch connector or wire is damaged.</li> <li>8. The electric clutch is damaged.</li> <li>9. The safety-interlock system prevents blade rotation.</li> <li>10. The PTO switch is malfunctioning.</li> </ol>	<ol style="list-style-type: none"> <li>1. Check the belt tension.</li> <li>2. Install the drive belt and check the adjusting shafts and belt guides for the correct position.</li> <li>3. Install the new deck belt.</li> <li>4. Install the deck pulley and check the idler pulley, idler arm and spring for the correct position and function.</li> <li>5. Replace the spring.</li> <li>6. Adjust the clutch air gap.</li> <li>7. Contact an Authorized Service Dealer.</li> <li>8. Contact an Authorized Service Dealer.</li> <li>9. Contact an Authorized Service Dealer.</li> <li>10. Contact an Authorized Service Dealer.</li> </ol>

# Schematics

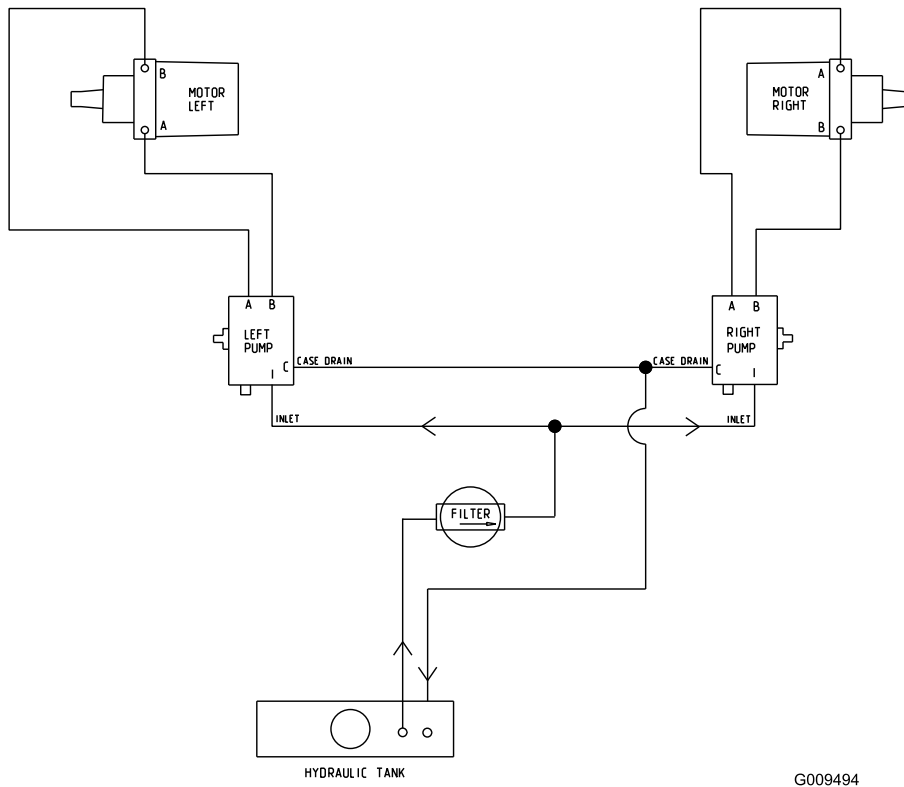

G009494

g009494

**Hydraulic Schematic (Rev. A)**

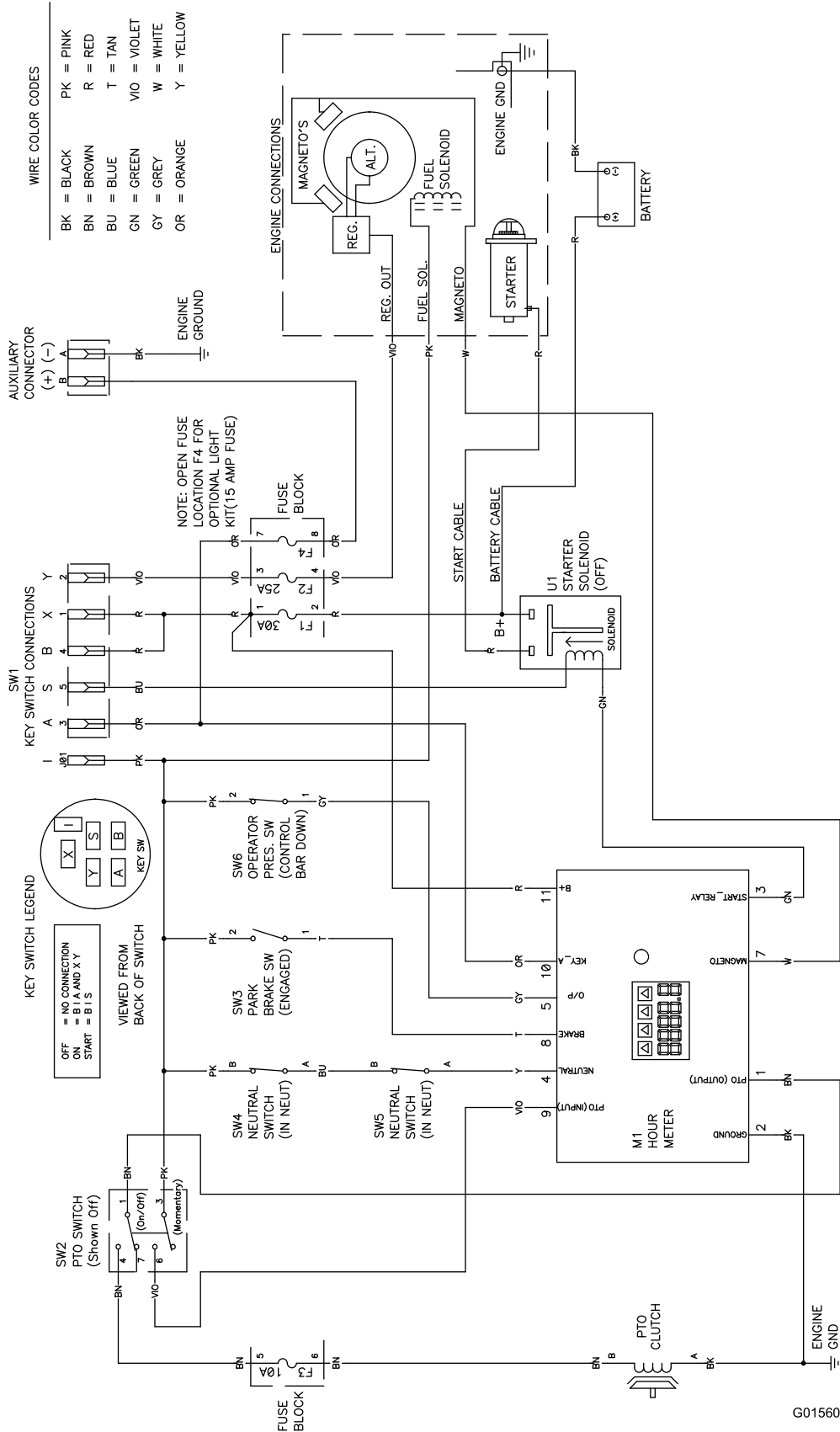

Electrical Schematic (Rev. A)

G015606

g015606

**Notes:**

**Notes:**

**Notes:**

## EEA/UK Privacy Notice

### **Toro's Use of Your Personal Information**

The Toro Company ("Toro") respects your privacy. When you purchase our products, we may collect certain personal information about you, either directly from you or through your local Toro company or dealer. Toro uses this information to fulfil contractual obligations - such as to register your warranty, process your warranty claim or to contact you in the event of a product recall - and for legitimate business purposes - such as to gauge customer satisfaction, improve our products or provide you with product information which may be of interest. Toro may share your information with our subsidiaries, affiliates, dealers or other business partners in connection these activities. We may also disclose personal information when required by law or in connection with the sale, purchase or merger of a business. We will never sell your personal information to any other company for marketing purposes.

### **Retention of your Personal Information**

Toro will keep your personal information as long as it is relevant for the above purposes and in accordance with legal requirements. For more information about applicable retention periods please contact [legal@toro.com](mailto:legal@toro.com).

### **Toro's Commitment to Security**

Your personal information may be processed in the US or another country which may have less strict data protection laws than your country of residence. Whenever we transfer your information outside of your country of residence, we will take legally required steps to ensure that appropriate safeguards are in place to protect your information and to make sure it is treated securely.

### **Access and Correction**

You may have the right to correct or review your personal data, or object to or restrict the processing of your data. To do so, please contact us by email at [legal@toro.com](mailto:legal@toro.com). If you have concerns about the way in which Toro has handled your information, we encourage you to raise this directly with us. Please note that European residents have the right to complain to your Data Protection Authority.