



Height-of-Cut Blocks

GrandStand® Mower

Model No. 133-1439

Installation Instructions

Note: Determine the left and right sides of the machine from the normal operating position.

Installation

Preparing the Machine

1. Park the machine on a level surface, disengage the PTO, move the motion-control levers to the NEUTRAL-LOCK position, and set the parking brake.
2. Shut off the engine, remove the key, and wait for all moving parts to stop before leaving the operating position.
3. Move the height-of-cut lever to the TRANSPORT position.
4. Move the height-of-cut pin to the 7 cm (2-3/4 inch) or lower position.
5. Check the air pressure in the rear tires; refer to the *Operator's Manual* for the machine.

Correcting the Height of Cut

1. Place the height-of-cut blocks below the mower deck so that the deck shell rests on the blocks when you lower the deck (**Figure 1**).

Note: Ensure that the blocks are not directly below the baffles on the front of the deck or the blades.

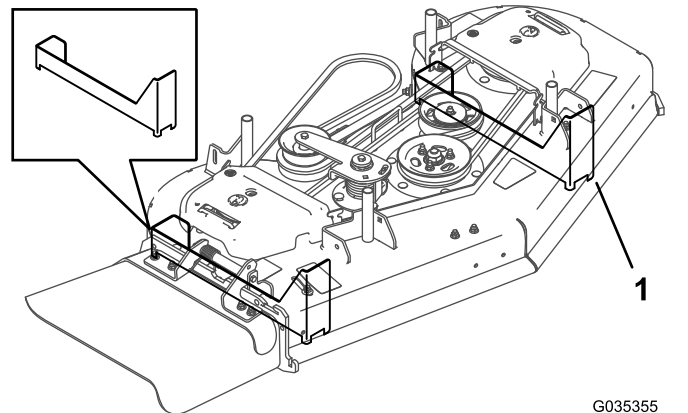

G035355
g035355

Figure 1

1. Height-of-cut block (below the deck)

2. Lower the deck onto the blocks.
3. Verify that only the deck shell is resting on the blocks.

Note: Ensure that the weight of the deck rests on the blocks and there is no tension on the linkages.



- Lightly pull back the height-of-cut lever with 1 finger and note the position of the lever relative to the tangent of the hole for the 7.6 cm (3 inch) height of cut ([Figure 2](#)).

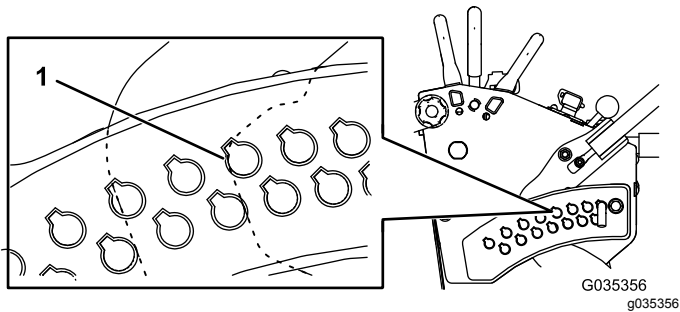

Figure 2

- Tangent for 7.6 cm (3 inch) height of cut

- Loosen the 2 jam nuts on the height-of-cut linkage ([Figure 3](#)).

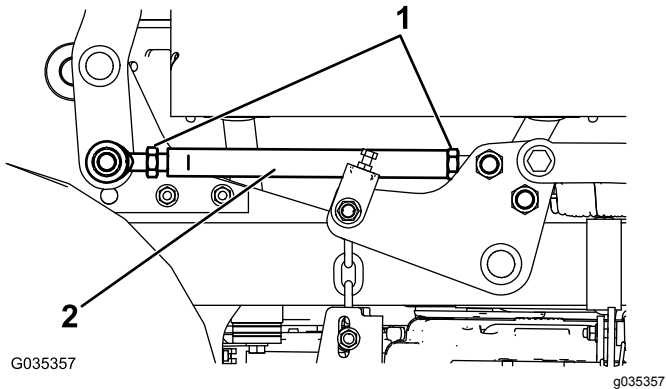

Figure 3

- Jam nut
- Height-of-cut linkage

- Adjust the linkage until the lever is tangent to the 7.6 cm (3 inch) hole when you pull back the lever with 1 finger ([Figure 2](#)).
- Tighten the 2 jam nuts.

- Loosen the jam nuts and side bolts in the yokes for the deck chains and linkages ([Figure 4](#)).

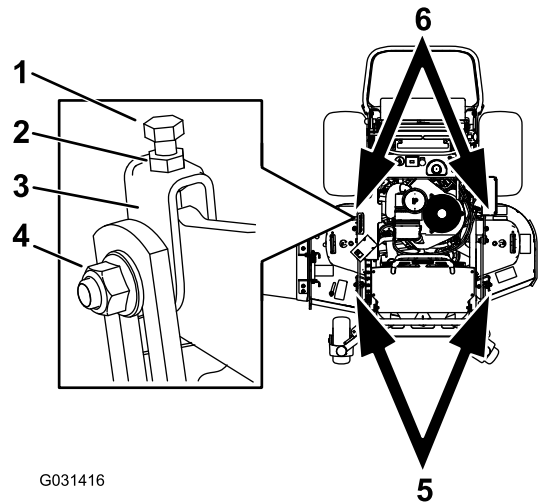

Figure 4

- | | |
|-------------|-------------|
| 1. Top bolt | 4. Side nut |
| 2. Jam nut | 5. Chains |
| 3. Yoke | 6. Linkages |

- Rotate the top bolt of the yokes clockwise until there is no slack in the chains and linkages ([Figure 4](#)).

Note: Do not overadjust the bolts. Overadjusting may prevent you from raising the deck to the TRANSPORT position.

- Tighten the jam nuts and side bolts ([Figure 4](#)).
- Verify that you can raise the deck to the TRANSPORT position.
- Remove the blocks.