

LAWN-BOY®

SilverPro Series™

Walk-behind Power Mower

Model No. 10247 – 9900001 & Up

Model No. 10252 – 9900001 & Up

Model No. 10323 – 9900001 & Up

Model No. 10324 – 9900001 & Up

Operator's Manual

Para obtener una versión gratis de este manual en español, escriba a la dirección indicada más abajo. Asegúrese de indicar el modelo y el número de serie de su producto.

Pour obtenir gratuitement une version en français de ce manuel, écrivez à l'adresse ci-dessous. N'oubliez pas d'indiquer les numéros de modèle et de série de votre produit.

Lawn-Boy Inc., Attn.: Parts Dept., 8111 Lyndale Ave S, Bloomington, MN 55420-1196.

Contents

	Page
Introduction	2
Safety	3
Safe Operating Practices	3
Safety and Instruction Decals	4
Assembly	5
Unfolding the Handle	5
Changing the Handle Height	5
Before Starting	5
Oil Mix Ratio	5
Mixing Gasoline and Oil	6
Operation	7
Starting the Engine	7
Stopping the Engine	7
Self-propel Drive	8
Adjusting the Cutting Height	8
Operating Tips	8
Maintenance	9
Recommended Maintenance Schedule	10
Air Filter	10
Maintaining the Spark Plug	11
Cleaning the Mower Housing	11
Maintaining the Blade	12
Lubricating the Self-propel Drive	14
Adjusting the Self-propel Cable	14
Cleaning the Self-propel Drive	14
Exhaust Ports	15
Troubleshooting	16
Accessories	17
Installing a Rear Grass Catcher	17
Installing the Cover Plate	19
Installing the Mulch Plate	19
Storage	20
Fuel	20
Engine	21
Folding the Handle	21
Removing From Storage	21
Warranty	Back Cover

The 2-stroke engine provided on this product meets the EPA Phase I Non-Road Emissions regulations for engines under 19 KW. This product does not comply to CARB TIER 1 regulations and cannot be sold in California.

Introduction

Thank you for purchasing a Lawn-Boy product.

All of us at Lawn-Boy want you to be completely satisfied with your new product, so feel free to contact your local Authorized Service Dealer for help with service, genuine Lawn-Boy parts, or other information you may require.

Whenever you contact your Authorized Service Dealer or the factory, always know the model and serial numbers of your product. These numbers will help the Service Dealer or Service Representative provide exact information about your specific product. You will find the model and serial number decal located in a unique place on the product as shown below.

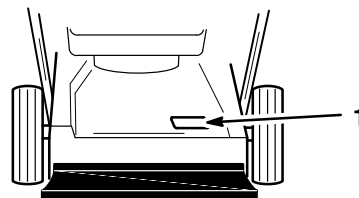

1064

1. Model and Serial Number Decal

For your convenience, write the product model and serial numbers in the space below.

<p>Model No: _____</p> <p>Serial No. _____</p>
--

Read this manual carefully to learn how to operate and maintain your product correctly. Reading this manual will help you and others avoid personal injury and damage to the product. Although Lawn-Boy designs, produces and markets safe, state-of-the-art products, you are responsible for using the product properly and safely. You are also responsible for training persons who you allow to use the product about safe operation.

The Lawn-Boy warning system in this manual identifies potential hazards and has special safety messages that help you and others avoid personal injury, even death. DANGER, WARNING and CAUTION are signal words used to identify the level of hazard. However, regardless of the hazard, be extremely careful.

DANGER signals an extreme hazard that will cause serious injury or death if the recommended precautions are not followed.

WARNING signals a hazard that may cause serious injury or death if the recommended precautions are not followed.

CAUTION signals a hazard that may cause minor or moderate injury if the recommended precautions are not followed.

Two other words are also used to highlight information. “Important” calls attention to special mechanical information and “Note” emphasizes general information worthy of special attention.

The left and right side of the machine is determined by standing behind the handle in the normal operator’s position.

Safety

This machine meets or exceeds CPSC blade safety requirements for walk-behind rotary mowers and the B71.1 specifications of the American National Standards Institute, in effect at time of production. However, improper use or maintenance by the operator or owner can result in injury. To reduce the potential for injury, comply with these safety instructions and always pay attention to the safety alert

 symbol which means CAUTION, WARNING or DANGER—“personal safety instruction.” Failure to comply with the instruction may result in personal injury.

Safe Operating Practices

This product is capable of amputating hands and feet and throwing objects. Always follow all safety instructions to avoid serious injury or death.

This mower is designed for cutting and mulching grass or, when equipped with a grass bag, for catching cut grass. Any use for purposes other than these could prove dangerous to user or bystanders.

Note: This engine is NOT equipped with a spark arrester muffler. Use or operation of this mower in your state on any forest-covered, brush-covered or unimproved grass-covered land, without an approved spark arrester muffler, may be a violation of the law.

WARNING

POTENTIAL HAZARD

- **Engine exhaust contains carbon monoxide, which is an odorless, deadly poison.**

WHAT CAN HAPPEN

- **Carbon monoxide can kill you.**

HOW TO AVOID THE HAZARD

- **Do not run engine indoors or in an enclosed area.**

General Operation

- Read this manual carefully before operating the mower. Become familiar with the controls and proper use of the mower. Never allow children to operate the mower or adults to operate it without proper instructions.
- Keep everyone, especially children and pets, away from the area of operation. Thoroughly inspect the area where the mower will be used and remove sticks, stones, wire, and debris.
- Wear long pants and substantial shoes. Do not operate the mower while wearing open-toed shoes, loose clothing, jewelry or when barefoot.
- Check the fuel level before starting the engine. Do not fill the fuel tank indoors, when the engine is running, or until the engine cools for several minutes after running. Wipe up spilled gasoline before starting the engine.
- Keep all guards, shields (including the rear trailing shield), grass catchers, and safety devices in place. Repair or replace damaged parts, including decals.
- The engine, blade and self-propel drive are designed to stop when control bails are released. Ensure that the control and brake function properly before each use of the mower.

While Operating

- Do not run the engine indoors.
- Always maintain secure footing. Keep a firm grip on the handle and walk; never run. Never operate the mower in wet grass. Mow only in daylight or in good artificial light.
- Mow across the face of slopes; never up and down. Use extreme caution when changing direction on slopes. Do not mow excessively steep slopes.
- Always wear safety glasses or eye shields during operation to protect eyes from foreign objects that may be thrown from the machine. Keep face, hands, and

feet away from the mower housing and cutter blade when the engine is running. Stay behind the handle until the engine stops.

- Since the blade rotates for a few seconds after the blade control bail is released, stay behind the handle until all movement stops.
- After striking a foreign object or if mower vibrates abnormally, stop the engine and remove the wire from the spark plug. Check the mower for damage and make all repairs before using it again.
- Stop the engine before adjusting the height-of-cut.
- Stop the blade/engine when crossing a gravel driveway, road, or sidewalk.
- Stop the engine before leaving the operator's position—behind the handle. Disconnect the wire from the spark plug if the mower will be unattended.
- Do not touch the engine while it is running or shortly after it is stopped because it will be hot enough to cause a burn.

- Before the mower is cleaned, inspected, serviced, or adjusted, stop the engine and disconnect the wire from the spark plug. Keep the wire away from the plug to prevent accidental starting.
- To ensure that the mower is in safe operating condition, frequently check and keep all nuts, bolts, and screws tight. Ensure that the blade nut/screw is tightened to 63 N·m (47 ft.-lbs.).
- To reduce fire hazard, keep the engine free of excessive grease, grass, leaves, and accumulations of dirt.
- Allow the engine to cool before storing the mower in any enclosure. Do not store the mower near any open flame or where gasoline fumes may be ignited by a spark.
- Do not overspeed the engine by changing governor settings.
- At the time of manufacture, the mower conformed to the safety standards in effect for rotary mowers. To ensure best performance and continued safety certification of the mower, use genuine Lawn-Boy replacement parts and accessories.

Maintenance

- Perform only those maintenance instructions described in this manual. If major repairs are ever needed or if assistance is desired, contact your local Authorized Lawn-Boy Service Dealer.

Safety and Instruction Decals



Safety decals and instructions are easily visible to the operator and are located near any area of potential danger. Replace any decal that is damaged or lost.



ON MOWER HOUSING
(Part No. 43-8480)

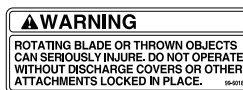

ON MOWER HOUSING
(Part No. 99-6018)



BY FRONT HEIGHT ADJUSTER
(Part No. 92-2914 Right)
(Part No. 92-2915 Left)



ON TOP OF GRASS CATCHER CHUTE
(Part No. 92-2919)
(Models 10324 and 10332)

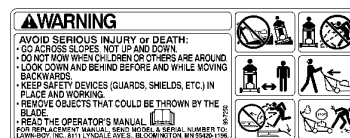

ON MOWER HOUSING
(Part No. 93-7250)

Assembly

Unfolding the Handle

1. Loosen the handle knobs and lift the top handle half in an arc until the handle halves are in line and nest together (Fig. 1).

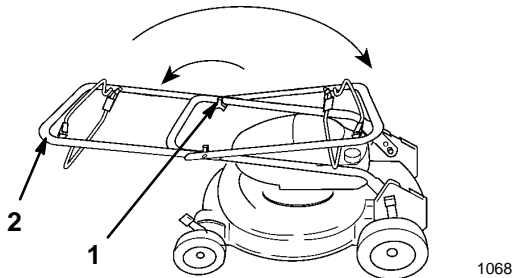

Figure 1

1. Knob
2. Top handle half

IMPORTANT: Use care to prevent pinching or stretching the cables.

2. Tighten the knobs securely.
3. Rotate the handle toward the rear of the mower until it snaps into the stops in the handle brackets.

Changing the Handle Height

The handle has two height positions—high and low (Fig. 2). Select a handle height position that is most comfortable for you.

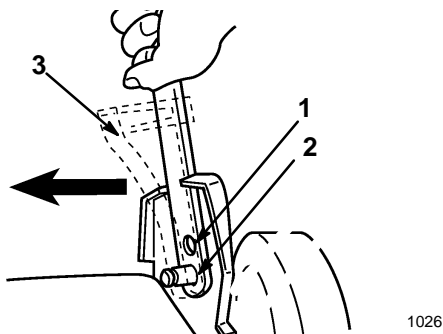

Figure 2

1. Low setting
2. High setting
3. Cable anchor – self-propelled model

1. Squeeze the bottom handle section (both sides) inward off of the pins.
2. Position the handle and cable anchor (self-propelled only) over the pins at the desired height.

Note: On self-propelled models, the belt cover may need to be loosened and moved slightly.

3. On self-propelled models, adjust the cable. Refer to Maintenance.

Before Starting

Oil Mix Ratio

Your Lawn-Boy mower is powered by a 2-cycle engine which requires a 32:1 mixture of gasoline and oil. Use only Lawn-Boy® Generation II, 2-Cycle Ashless Oil, packaged in purple/green cans (Fig. 3) or an equivalent premium grade 2-cycle ashless oil, certified NMMA TCW III. Failure to use the correct oil or mixture ratio could result in serious engine damage.



Figure 3

Lawn-Boy Generation II, 2-Cycle Ashless Oil is formulated for Lawn-Boy and is available from your Lawn-Boy retailer. Regular use of Lawn-Boy Generation II, 2-Cycle Ashless Oil will help keep your engine clean, reduce spark plug fouling, piston ring sticking and pre-ignition. Lawn-Boy Generation II, 2-Cycle Ashless Oil will also minimize varnish build-up, combustion chamber deposits and exhaust port blockage.

IMPORTANT: Never use automotive oil (i.e. SAE 30, 10W30 etc.) or the wrong mix ratio because engine damage may occur. If engine failure occurs and it has been determined that Lawn-Boy Generation II, 2-Cycle Ashless Oil or an NMMA TCW III certified oil was not used, the failure may not be covered by the Lawn-Boy warranty.

Mixing Gasoline and Oil



DANGER



POTENTIAL HAZARD

- When fueling, under certain circumstances, a static charge can develop, igniting the gasoline.

WHAT CAN HAPPEN

- A fire or explosion from gasoline can burn you and others and cause property damage.

HOW TO AVOID THE HAZARD

- Always place gasoline containers on the ground away from your vehicle before filling.
- Do not fill gasoline containers inside a vehicle or on a truck or trailer bed because interior carpets or plastic truck bed liners may insulate the container and slow the loss of any static charge.
- When practical, remove gas-powered equipment from the truck or trailer and refuel the equipment with its wheels on the ground.
- If this is not possible, refuel such equipment on a truck or trailer from a portable container, rather than from a gasoline dispenser nozzle.
- If a gasoline dispenser nozzle must be used, keep the nozzle in contact with the rim of the fuel tank or container opening at all times until fueling is complete.



DANGER



POTENTIAL HAZARD

- In certain conditions gasoline is extremely flammable and highly explosive.

WHAT CAN HAPPEN

- A fire or explosion from gasoline can burn you, others, and cause property damage.

HOW TO AVOID THE HAZARD

- Use a funnel and fill the fuel tank outdoors, in an open area, when the engine is cold. Wipe up any gasoline that spills.
- Do not fill the fuel tank completely full. Add gasoline to the fuel tank until the level is 1/4" to 1/2" (6 mm to 13 mm) below the bottom of the filler neck. This empty space in the tank allows gasoline to expand.
- Never smoke when handling gasoline, and stay away from an open flame or where gasoline fumes may be ignited by a spark.
- Store gasoline in an approved container and keep it out of the reach of children.
- Never buy more than a 30-day supply of gasoline.

For simplicity and best engine performance, mix 8 ounces (250 ml) of Lawn-Boy Generation II, 2-Cycle Ashless Oil with two gallons (8 liters) of fresh, unleaded regular gasoline. Pour one gallon (4 liters) of gasoline into an approved gasoline container and add the correct amount of 2-cycle oil. Install cap on gasoline container and shake to mix oil and gasoline thoroughly (Fig. 4). Slowly remove the cap and add the remaining gasoline.



Figure 4

1056

Note: Do not mix gasoline and oil in the product fuel tank. Oil that is at room temperature mixes easily and more thoroughly than cold oil.

Use clean, fresh lead-free gasoline with an octane rating of 85 or higher. Purchase only the quantity of gasoline that can be used in 30 days to ensure freshness. Use of lead-free gasoline results in fewer combustion chamber deposits and longer spark plug life. Leaded gasoline may be used if lead-free is not available.

IMPORTANT: Never use methanol, gasoline containing methanol, gasohol containing more than 10% ethanol, premium gasoline, or white gas because the engine fuel system could be damaged.

1. Clean around the fuel cap and remove it (Fig. 5).
2. Fill the fuel tank with gasoline/oil mix to within 1/4 inch (6.5 mm) of top of tank, not into the filler neck.

IMPORTANT: Do not over fill the fuel tank. The gasoline/oil mix must have room to expand.

3. Replace the fuel cap securely and wipe up any spilled fuel.

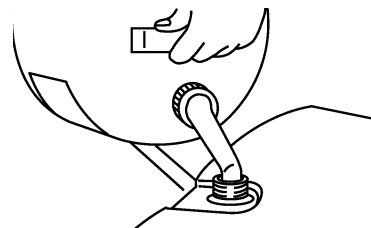

Figure 5

993

Note: Lawn-Boy recommends that Lawn-Boy 2+4® Fuel Conditioner (Fig. 6) be used during operation and storage. Lawn-Boy 2+4® Fuel Conditioner cleans the engine and prevents gum-like varnish deposits from forming during storage.



Figure 6

1058

IMPORTANT: Do not use fuel additives other than those manufactured for fuel stabilization during storage, such as Lawn-Boy 2+4® Fuel Conditioner. Lawn-Boy does not recommend stabilizers with an alcohol base such as ethanol or methanol. Stabilizers should not be used to try to enhance the power or performance of the machine.

4. Connect the spark plug wire (if disconnected) (Fig. 7).

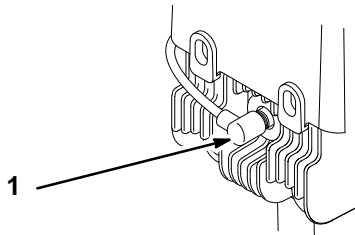



Figure 7

m-3884

1. Spark plug wire

Operation

Starting the Engine

1. Move the throttle lever to the  position (Fig. 8).

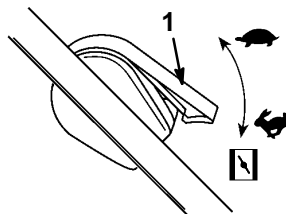

Figure 8

1019

1. Throttle lever

2. Push the primer three times (Fig. 9). Wait about two seconds between each push.

Note: To restart a warm engine, press the primer only once.

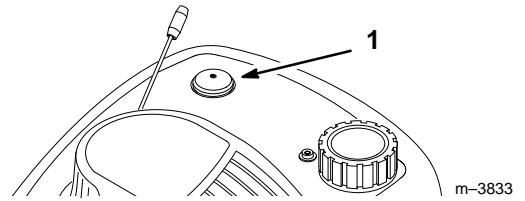

Figure 9

1. Primer

3. Hold the blade control bail against the upper handle (Fig. 10).

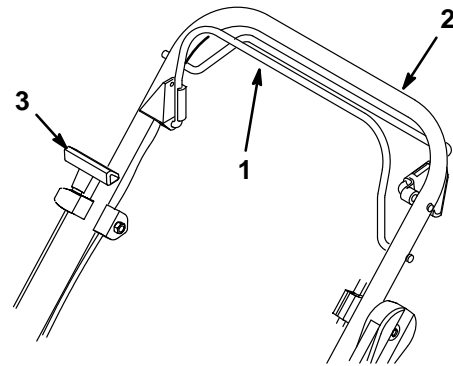

Figure 10

982



1. Blade control bail



2. Upper handle

3. Starter handle

4. Pull the starter handle lightly until resistance is felt, then pull it sharply (Fig. 10). Let the rope return to the handle slowly.

5. If the engine fails to start, repeat steps 2 through 4.

Note: If the engine starts but then begins to stall, move the throttle lever to the  position until the engine continues to run, then move the throttle back to the  position.

In cool temperatures, it may be necessary to prime three times with the throttle lever in the  position, and then start the engine. Once the engine has started, move the throttle lever to the  position.

Stopping the Engine

1. Move throttle lever to the  position (Fig. 8).

2. Release the blade control bail (Fig. 11). Both the engine and blade will stop. See your dealer immediately if they do not.

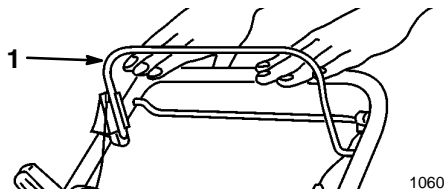

Figure 11

1. Blade control bail

Self-propel Drive

Self-propelled Models Only

1. To operate the self-propel drive, squeeze the self-propel bail against the handle and hold it (Fig. 12).

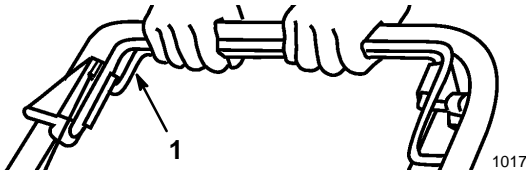

Figure 12

1. Self-propel bail

Note: Maximum self-propel ground speed is fixed. To reduce ground speed, increase the space between the bail and the handle.

2. To disengage the self-propel drive, release the self-propel bail (Fig. 13), then push the mower forward manually at least 1 in.

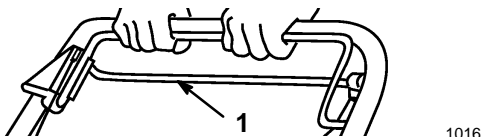

Figure 13

1. Self-propel bail

Adjusting the Cutting Height

Each wheel is adjusted individually with a wheel height adjustment lever. Cutting heights are 1", 1-1/2", 2", 2-1/2", 3" and 3-1/2 inches (25, 38, 51, 64, 74 and 86 mm).



DANGER



POTENTIAL HAZARD

- Adjusting the height-of-cut levers could bring your hands into contact with a moving blade.

WHAT CAN HAPPEN

- Contact with a rotating blade can cause serious injury.

HOW TO AVOID THE HAZARD

- Stop the engine and wait for all movement to stop before adjusting the cutting height.
- Do not put fingers under the housing when adjusting the height-of-cut.

1. Pull the adjusting lever toward the wheel and move it to the desired position (Fig. 14).

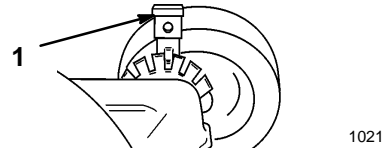

Figure 14

1. Wheel height adjustment lever

2. Release the height adjust lever and seat it securely in the desired notch.



Note: Set all four (4) wheels to the same height.

Operating Tips

General Tips

- Review the safety instructions and read this manual carefully before operating the mower.
- Clear the area of sticks, stones, wire, branches, and other debris which could be picked up or hit by the blade and become thrown objects.
- Keep everyone, especially children and pets, away from the area of operation.
- Avoid striking trees, walls, curbs, or other solid objects. Never deliberately mow over any object.
- If an object is struck, or the mower starts to vibrate, immediately stop the engine, disconnect the spark plug wire, and examine the mower for damage.
- Maintain a **sharp blade** throughout the cutting season. Periodically file down nicks on blade.
- Replace the blade when necessary with an original Lawn-Boy replacement blade.

- Only mow dry grass or leaves. Wet grass and leaves tend to clump and may cause the mower to plug or the engine to stall. They may also be slippery to walk on and could cause you to slip and fall.

 WARNING 
<p>POTENTIAL HAZARD</p> <ul style="list-style-type: none"> • Wet grass or leaves can cause you to slip and contact the blade. <p>WHAT CAN HAPPEN</p> <ul style="list-style-type: none"> • Blade contact can seriously injure you. <p>HOW TO AVOID THE HAZARD</p> <ul style="list-style-type: none"> • Mow only in dry conditions.

- Clean clippings or leaves from the underside of the mower deck after each mowing.
- Keep the engine in good running condition.
- Clean the air filter frequently. Mulching stirs up more clippings and dust which clogs the air filter and reduces engine performance.

Cutting Grass

- In the heat of Summer, cut the grass at the 2, 2.5, or 3 inch height-of-cut settings. Only about 1/3 of the grass blade should be cut off. Cutting below the 2 inch setting is not recommended unless the grass is sparse or it is late Autumn when grass growth begins to slow down.
- When cutting grass over six inches tall, mow using the highest height-of-cut setting and a slower walking speed; then mow again at a lower setting for best lawn

Maintenance

NOTICE: Maintenance, replacement, or repair of the emission control devices and systems may be performed by any nonroad engine repair establishment or individual. However, to obtain no charge repairs under the terms and provisions of the Lawn-Boy warranty statement, any service or emission control part repair or replacement must be performed by an Authorized Lawn-Boy Service Dealer.

Continued safe and dependable operation requires routine maintenance.

appearance. If the grass is too long and leaves clumps on top of the lawn, the mower may plug and cause the engine to stall.

- Alternate the mowing direction. This helps disperse clippings over the lawn for even fertilization.

If the finished lawn appearance is unsatisfactory, try one or more of the following:

- Sharpen the blade.
- Walk at a slower pace while mowing.
- Raise the height-of-cut setting on your mower.
- Cut grass more frequently.
- Overlap cutting swaths instead of cutting a full swath with each pass.
- Set the height-of-cut on the front wheels one notch lower than the rear wheels. (example: set the front wheels at the 2 inch setting and the rear wheels at the 2.5 inch setting)

Cutting Leaves

- When cutting is complete, ensure that 50% of the lawn shows through the cut leaf cover. This may require one or more passes over the leaves.
- Position all wheels at the same height-of-cut setting.
- Walk at a slower mowing speed if the leaves are not being cut up finely enough to be hidden in the grass.
- If you cut up a lot of oak leaves, add lime to your grass in the spring. Lime reduces the acidity of the oak leaves.

Recommended Maintenance Schedule

Service Item	Service Operation	Each Use	25 Hours	50 Hours	100 Hours
Fasteners	Check blade and engine mounting fasteners frequently. Keep all nuts, bolts and screws tight to ensure safe operation.	X			
Blade Brake	Check stopping time before each use. Blade must stop within 3 seconds of releasing bail; if not see your Authorized Lawn-Boy Service Dealer for repair.	X			
Housing	Clean built-up grass clippings and dirt after each use.	X			
Air Filter	Remove and clean each mowing season or every 50 hours. Clean more frequently if operating conditions are dusty.			X	
Spark Plug	Clean, inspect, and gap. Replace if necessary.			X	
Self-propel Drive	Clean grass clippings and debris under belt cover and drive belt.		X		
Blade	Sharpen or replace; maintain more frequently if edge is dulled quickly in rough or sandy conditions.			X	
Lubrication	Grease rear height adjuster brackets (self-propelled models).			X	
Exhaust Port	Clean every 100 hours.				X
Fuel System	Check for leakage and/or deterioration of fuel hose. Replace if necessary.			X	
Cooling System	Clean grass clippings, debris or dirt that clog engine air cooling fins and starter. Clean more frequently under dirty or high chaff conditions.				X

! **CAUTION** !

POTENTIAL HAZARD

- If you leave the wire on the spark plug, someone could start the engine.

WHAT CAN HAPPEN

- Accidental starting of engine could seriously injure you or other bystanders.

HOW TO AVOID THE HAZARD

- Pull wire off spark plug before you do any maintenance. Also push wire aside so it does not accidentally contact spark plug.

Air Filter

Clean the air filter once every season or every 50 hours; **clean it more frequently under dusty conditions.**

Note: Do not operate the engine without the air filter element; extreme engine damage will occur.

1. Snap the air filter cover latch open and swing it to the side (Fig. 15).

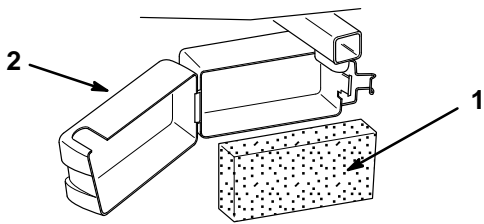

m-3834

Figure 15

1. Filter
2. Cover

2. Remove the air filter.
3. Wash the air filter in laundry detergent or kerosene (Fig. 16).

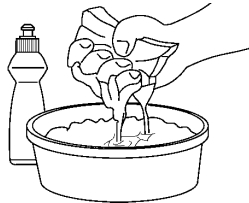

988

Figure 16

4. Squeeze the filter to remove excess liquid and blot it dry with a paper towel or rag.
5. Apply one tablespoon of SAE 30W oil to the air filter (Fig. 17).

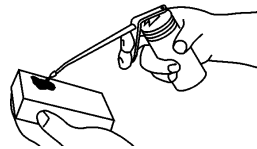

989

Figure 17

6. Squeeze the filter until the oil is distributed evenly. Blot it lightly with a paper towel to remove excess oil.
7. Replace the filter with cleanest side facing the carburetor.

Note: Ensure that the filter is fully seated in the air box and does not pucker, allowing direct passage of air and dirt.

Maintaining the Spark Plug

A spark plug that is dirty, pitted, carbon-covered, or has worn electrodes may cause hard starting and poor operation.

Clean or replace the spark plug once a season or every 50 hours, whichever occurs first. Use an NGK BPMR4A spark plug.

1. Disconnect the spark plug wire (Fig. 7).
 2. Remove the spark plug and clean it with a wire brush, removing carbon build-up.
- IMPORTANT: Do not sand-blast the spark plug.**
3. Check the condition of the plug for cracks and damaged or worn electrodes. Replace it if necessary.
 4. Set the spark plug gap at .035 inch (.85 mm) (Fig. 18).

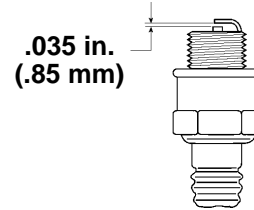

986

Figure 18

5. Install the spark plug by hand, then torque it to 180 in-lbs. (15 ft-lbs.) (20 N·m).
6. Connect the spark plug wire.

Cleaning the Mower Housing

A clean mower housing provides the best cutting performance. Check for grass build-up and clean it after each use.

Washing Method

1. Position the mower on a flat, concrete or asphalt surface near a garden hose.
2. Start the engine.
3. Hold the running garden hose at handle level and direct the water to flow on the ground just in front of the right rear tire (Fig. 19).

The blade will draw in water and wash out clippings. Let the water run until you no longer see clippings being washed out from under housing.

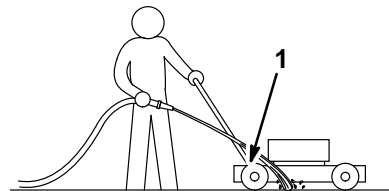

1093

Figure 19



1. Rear right wheel
4. Stop the engine.
5. Turn off the garden hose.

6. Start the mower and let it run for a few minutes to dry out the moisture on the mower and its components.
7. While the engine is running, engage and disengage the traction drive several times to dry it out.

Scraping Method

If washing does not remove all debris from under the mower, tip it and scrape it clean.

1. Run the engine dry or remove gas with a hand pump when the engine is cool.

 WARNING 
<p>POTENTIAL HAZARD</p> <ul style="list-style-type: none"> • Gasoline is extremely flammable, highly explosive and under certain conditions can cause personal injury or property damage. <p>WHAT CAN HAPPEN</p> <ul style="list-style-type: none"> • Tipping the mower may cause fuel leakage from carburetor or fuel tank. <p>HOW TO AVOID THE HAZARD</p> <ul style="list-style-type: none"> • Avoid fuel spills by running the engine dry or removing gas with hand pump; never siphon.

2. Disconnect the spark plug wire (Fig. 7).
3. Tip the mower onto its right side (Fig. 20).

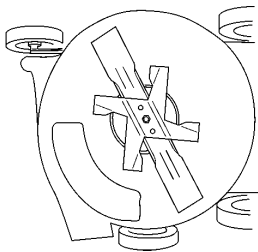



Figure 20

Note: When the mower is tipped on its side, rotate the blade as little as possible to avoid starting problems.

4. Scrape built-up grass clippings and dirt from the mower housing with a hardwood scraper.
5. Tip the mower upright.
6. Connect the spark plug wire.

Maintaining the Blade

A straight, sharp blade provides maximum cutting performance. Regularly inspect and sharpen the blade.

 WARNING 
<p>POTENTIAL HAZARD</p> <ul style="list-style-type: none"> • The blade is sharp. <p>WHAT CAN HAPPEN</p> <ul style="list-style-type: none"> • Contact with the sharp blade can cause serious personal injury. <p>HOW TO AVOID THE HAZARD</p> <ul style="list-style-type: none"> • Wear gloves or wrap the sharp edges of the blade with a rag.

1. Disconnect the spark plug wire (Fig. 7).
2. Tip the mower onto its right side (Fig. 20).

Checking for Blade Straightness

Measure the distance from the bottom edge of the mower housing to the blade tip (Fig. 21). Rotate the blade 180° and measure to the other blade tip.

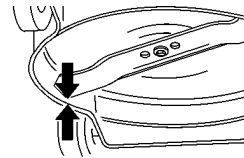

Figure 22

Note: If the measurements are not within 1/8 inch (3.2 mm), the blade should be replaced. If, after blade replacement, the measurements are still not within 1/8 inch (3.2 mm), the crankshaft should be checked for straightness by your Authorized Lawn-Boy Service Dealer.

Inspecting the Blade

1. Examine the blade for sharpness and wear, especially where the flat and curved parts meet (Fig. 23A).
2. Complete one of the following:
 - A. If a slot or wear is noticed, (Fig. 23B & C), replace the blade. Refer to the Removing and Installing the Blade sections.
 - B. If the blade is nicked or dull, sharpen it. Refer to the Removing, Sharpening, Balancing, and Installing the Blade sections.

- C. If there are no signs of wear or dullness, return the mower to the upright position and replace the spark plug wire (Fig. 7).

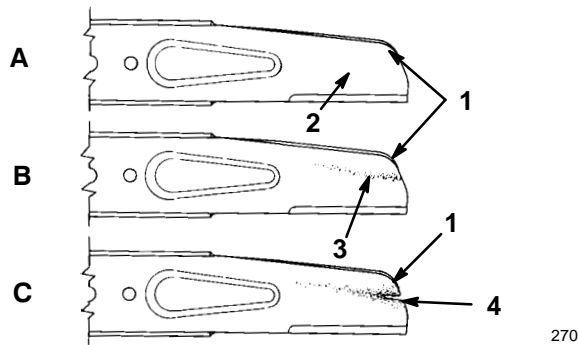

Figure 23

- | | |
|-----------------------|----------------|
| 1. Sail | 3. Wear |
| 2. Flat part of blade | 4. Slot formed |

! **DANGER** !

POTENTIAL HAZARD

- A worn or damaged blade could break and a piece of the blade could be thrown into the operator's or bystander's area.

WHAT CAN HAPPEN

- A thrown piece of the blade could cause serious personal injury or death to the operator or bystanders.

HOW TO AVOID THE HAZARD

- Inspect the blade periodically for wear or damage.
- Replace a worn or damaged blade.

Removing the Blade

1. Remove the blade nut and mulching fan (Fig. 24).
2. Remove the blade from the blade driver (Fig. 24).

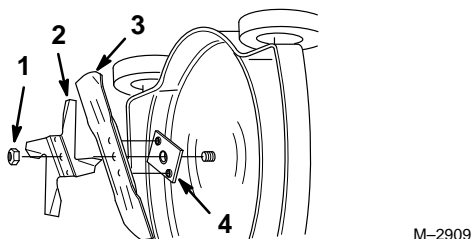

Figure 24

- | | |
|-----------------|-----------------|
| 1. Blade nut | 3. Blade |
| 2. Mulching fan | 4. Blade driver |

3. Examine the mulch fan for worn or bent blades. Replace it if necessary.
4. Examine the blade driver for bent or sheared drive lugs. Replace it if necessary.

Sharpening the Blade

Using a file, sharpen top side of the blade and maintain the original cutting angle (Fig. 25).

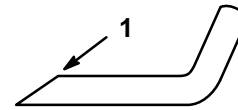

Figure 25

1. Sharpen at this angle only

Note: The blade will remain balanced if same amount of material is removed from both cutting edges.

Note: The blade should not be ground more than 5 inches (127 mm) from the outside ends and no less than 2 inches (51 mm) from the trailing edge (Fig. 26).

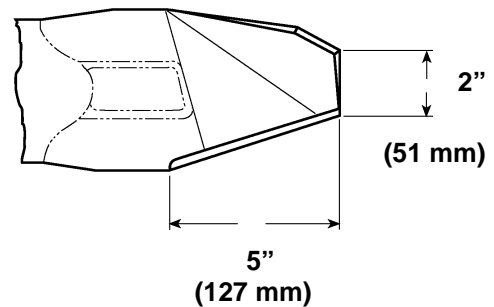

Figure 26

Balancing the Blade

1. Check the balance of the blade by placing the center hole of the blade over a nail or screwdriver shank clamped horizontally in a vise (Fig. 27).

Note: You can also check the balance using a commercially manufactured, blade balancer.

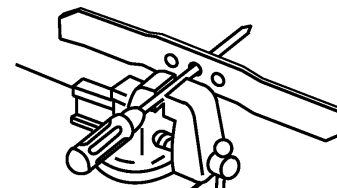

Figure 27

- If either end of the blade rotates downward, file that end (not the cutting edge or the end near the cutting edge). The blade is properly balanced when neither end drops.

Installing the Blade

- Install the blade driver onto the crankshaft (if removed) (Fig. 24).
- Install the blade over the lugs of the blade driver with the curved ends toward the mower housing (Fig. 24).
- Install the mulch fan into the blade recess (Fig. 24).
- Secure the blade with the blade nut (Fig. 28).

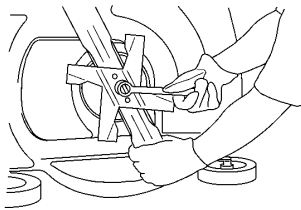

Figure 28

1024

- Torque the blade nut to 47 ft-lbs. (63 N·m).

Note: The blade nut must be replaced after installing and removing it four times. The locking feature will decrease and the nut could loosen if not replaced.

- Connect the spark plug wire (Fig. 7).

Lubricating the Self-propel Drive

Self-propelled Models Only

- Wipe the grease fittings on the rear height-of-cut adjusters (Fig. 29) with a clean rag.

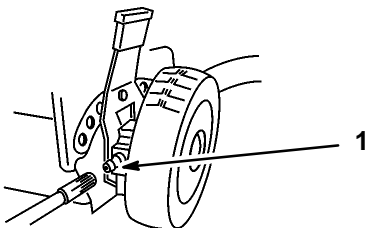

Figure 29

1018

- Grease fittings

- Install a grease gun onto each fitting in turn and gently apply one or two pumps of #2 multi-purpose lithium grease to each.

IMPORTANT: Excess grease may damage the seals and prevent proper wheel clutch operation.

Adjusting the Self-propel Cable

Self-propelled Models Only

Whenever the handle height is changed, a new self-propel cable is installed, or the traction drive belt slips, adjustment is required.

The self-propel cable is adjusted on the handle by moving the cable jacket held by the cable support.

- Loosen the nut on the cable support (Fig. 30).
- Hold the self-propel bail 1 to 1½ in. (25 to 38 mm) from the handle (Fig. 30).

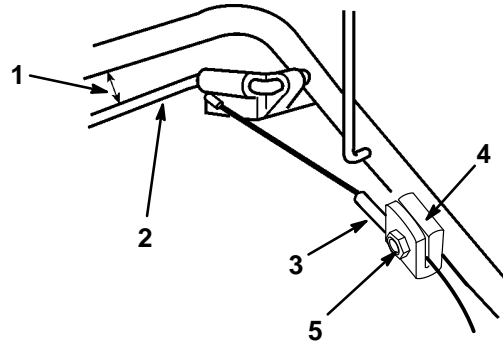

Figure 30

1063

- | | |
|------------------------------|------------------|
| 1. 1 to 1½ in. (25 to 38 mm) | 4. Cable support |
| 2. Self-propel bail | 5. Nut |
| 3. Cable jacket | |

- Pull the cable jacket down (away from bail) to remove the slack in the cable between the bail and the cable support..

- Tighten the nut on the cable support.

- Release the bail and ensure that the cable is loose.

Note: The cable must be loose when the bail is released or the mower may creep when the bail is disengaged.

Cleaning the Self-propel Drive

Self-propelled Models Only

Under certain conditions, clippings can collect under the belt drive cover and in the pulley groove. This could cause belt slippage, loss of self-propel drive, or failure to disengage the self-propel drive.

Clean grass clippings and debris from under the belt cover every 25 hours of operation.

- Remove the screw from the belt cover (Fig. 31).

- Unhook the cable spring from the drive bracket (Fig. 31).

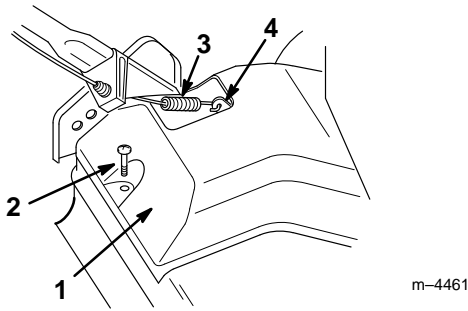

Figure 31

- | | |
|---------------|------------------|
| 1. Belt cover | 3. Cable spring |
| 2. Screw | 4. Drive bracket |

- Remove the belt cover by pulling it straight out from the engine.

Note: If the belt cover is pinched between the handle and handle bracket, remove the handle before removing the belt cover. Refer to Changing the Handle Height, page 5, for more information.

- Remove debris from under the cover and pulley groove.
- Replace the belt cover by squeezing the sides together and inserting the tabs on the belt cover into the brackets on the engine base (Fig. 32).

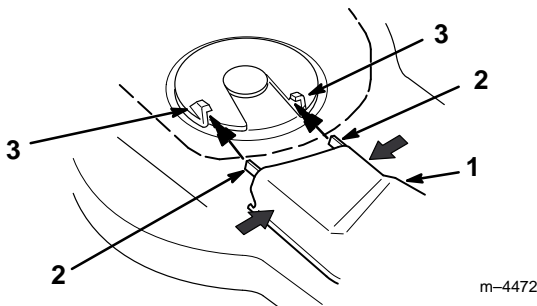

Figure 32

- | | |
|---------------|------------|
| 1. Belt cover | 3. Bracket |
| 2. Tab | |

- Secure the belt cover with the screw.
- Hook the cable spring onto the drive bracket.

Exhaust Ports

Carbon deposit build-up causes excessive wear and loss of power. Check and clean them every 100 hours.

- Disconnect the spark plug wire (Fig. 7).
- Drain the gasoline using a hand pump.

- Tip the mower on its right side.

! **WARNING** !

POTENTIAL HAZARD

- Gasoline is extremely flammable, highly explosive and under certain conditions can cause personal injury or property damage.

WHAT CAN HAPPEN

- Tipping the mower may cause fuel leakage from the carburetor or fuel tank.

HOW TO AVOID THE HAZARD

- Avoid fuel spills by running the engine dry or removing the gas with hand pump; never siphon.

- Remove the blade nut, mulch fan, and blade. Refer to the Removing the Blade section, page 13.
- Remove the four capscrews attaching the cover plate to the engine mounting plate (Fig. 33).
- Remove the transfer pipe (Fig. 33).
- Inspect the transfer pipe and clean it if it is dirty.

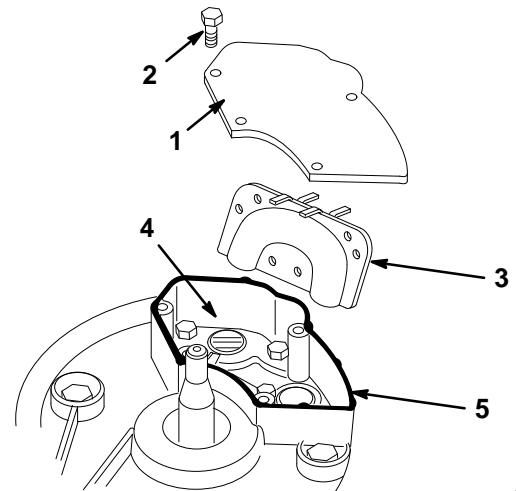

Figure 33

- | | |
|------------------|--------------------------------------|
| 1. Cover plate | 4. Exhaust port |
| 2. Cap screw | 5. High temperature silicone sealant |
| 3. Transfer pipe | |

- Rotate the crankshaft slowly until the piston covers the exhaust port (Fig. 33).
- Using a wooden dowel, loosen carbon deposits by inserting the dowel into the port.

Note: Do not use metal tools; they could scratch the piston.

- Set mower the upright.

11. Hold the blade control bail against the upper handle (Fig. 34) and pull the starter rope several times to blow out loose carbon.

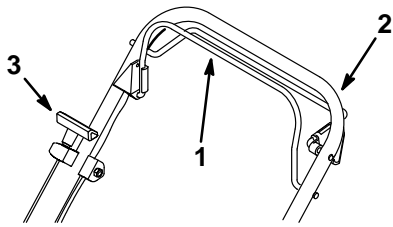

Figure 34

1. Blade control bail
2. Upper handle
3. Starter handle

12. Wipe the bottom of the cover plate and the edge of the engine mounting plate where the sealant will go with a clean cloth to remove any dirt (Fig. 33).

Troubleshooting

Your mower was designed and built for trouble-free operation. Check the following components and items carefully. If a problem continues, see your Authorized Lawn-Boy Service Dealer.

PROBLEM	CORRECTIVE ACTION
Engine will not start	<ol style="list-style-type: none"> 1. Fill the fuel tank with fresh gasoline/oil mix 2. Move throttle lever to the FAST position 3. Press the primer three times 4. Spark plug <ul style="list-style-type: none"> • Connect the spark plug wire • Clean the spark plug, check the spark plug gap, and replace it if it is damaged
Engine starts hard or loses power	<ol style="list-style-type: none"> 1. Move the throttle lever to the FAST position. 2. Drain and refill the fuel tank with fresh gasoline/oil mix 3. Clean the gas cap vent hole 4. Clean or replace the air filter element 5. Clean the mower discharge chute 6. Clean the underside of the mower deck 7. Clean the spark plug, check the spark plug gap, and replace it if it is damaged
Engine runs rough	<ol style="list-style-type: none"> 1. Connect the spark plug wire 2. Clean the spark plug, check the spark plug gap, and replace it if it is damaged 3. Move the throttle lever to the FAST position 4. Clean or replace the air filter element

13. Run a bead of high temperature, automotive silicone sealant along the edge of the engine mounting plate where the cover plate will rest (Fig. 33).

14. Install the transfer pipe and cover plate (Fig. 33), torquing the four capscrews to 75 in-lbs. (8.5 N·m).

15. Install the blade driver, blade, and mulch fan with the blade nut. Refer to the Installing the Blade section, page 14.

16. Torque the blade nut to 560 in-lbs. (47 ft-lbs.) (63 Nm).

17. Tip the mower upright.

18. Connect the spark plug wire.

PROBLEM	CORRECTIVE ACTION
Mower or engine vibrates excessively	<ol style="list-style-type: none"> 1. Balance the blade 2. Tighten the blade mounting nut 3. Clean the mower discharge chute 4. Clean the underside of the mower deck 5. Tighten the engine mounting bolts
Uneven cutting pattern	<ol style="list-style-type: none"> 1. Place all four wheels at same height 2. Sharpen and balance the blade 3. Change the mowing pattern 4. Clean the underside of the mower deck
Discharge chute plugs	<ol style="list-style-type: none"> 1. Move throttle lever to the FAST position 2. Raise the cutting height 3. Allow grass to dry before mowing 4. Clean the underside of the mower deck
Mower will not self-propel	<ol style="list-style-type: none"> 1. Adjust the self-propelled cable 2. Clean debris from under the belt cover

Accessories

Accessories may have been shipped with your mower or are available from your Authorized Lawn-Boy Dealer. For proper installation, follow these instructions.

Installing a Rear Grass Catcher

1. Stop the engine and disconnect the spark plug wire (Fig. 7).
2. Remove the wing screw that fastens the cover plate to the housing (Fig. 35).

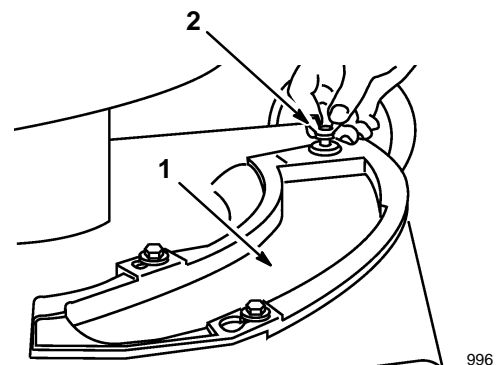

Figure 35

1. Cover or mulch plate
 2. Wing screw
-
3. Slide the cover plate counterclockwise and remove it from the mower housing.
 4. Place the front corner of the chute baffle into the deck opening. Rotate the chute counterclockwise and push it down into the deck opening (Fig. 36).

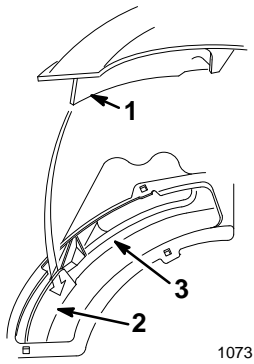

Figure 36

- 1. Chute baffle
- 2. Deck baffle
- 3. Toe guard

Note: The chute baffle must go behind the front deck baffle and between the blade and toe guard to prevent contact with the blade.

- 5. Insert the chute support rod through the hole in the right side of the deck (Fig. 37).

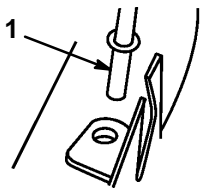

Figure 37

- 1. Chute support rod

- 6. Push the key hole slots on the chute down over the two shoulder bolts on the mower housing, and slide the chute clockwise to lock it in place.

- 7. Secure the chute assembly with the wing screw (Fig. 38).

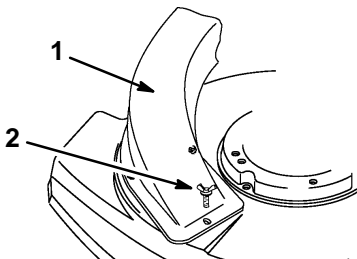

Figure 38

- 1. Chute assembly
- 2. Wing screw

- 8. Check the clearance between the blade tips and the baffle, ensuring that there is no contact (Fig. 39).

Note: The baffle must go behind the front deck baffle and between the blade and toe guard to prevent contact with the blade (Fig. 39).

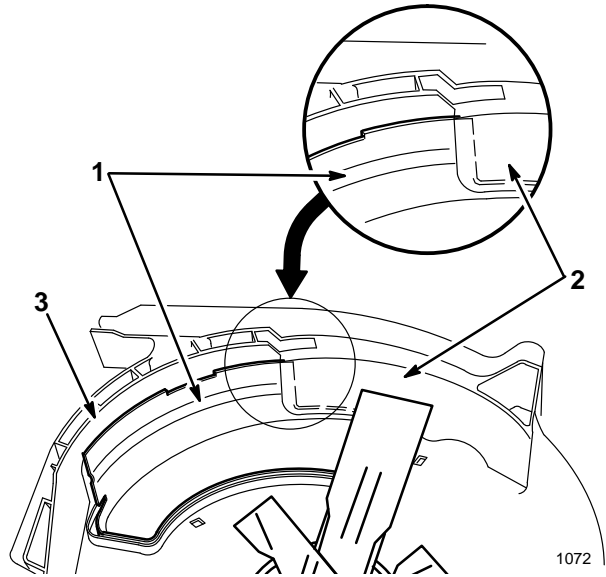

Figure 39

- 1. Baffle
- 2. Front deck baffle
- 3. Toe guard

- 9. Remove the knob and bolt securing the left side upper and lower handle sections (Fig. 40).

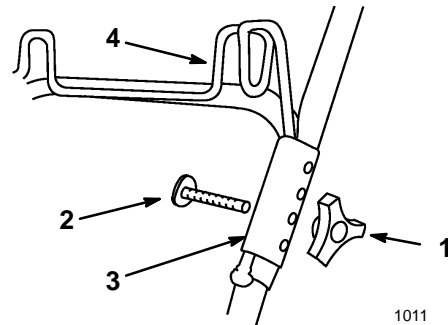

Figure 40

- 1. Knob
- 2. Bolt
- 3. Hanger clamp
- 4. Bag hanger

- 10. Hold a hanger clamp on the outside of the handle sections, and insert a bolt from the inside of the handle sections through the holes in the hanger clamp (Fig. 40).

- 11. Position the bag hanger leg into the hanger clamp groove and secure it with a knob (Fig. 40).

- 12. Repeat steps 9 through 11 for the other side.

13. Close the rear of the bag by folding the sides in and pressing the interlocking rear handle halves together (Fig. 41).

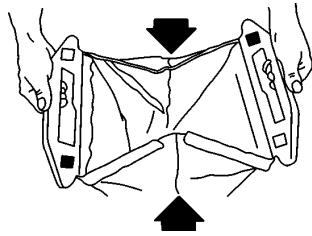

Figure 41

1012

14. Hang the rear bag handles on the bag hanger on the handle.
15. Grasp the bag assembly handle and slide it over the flange of the grass chute (Fig. 42). Push downward on the handle until it seats into position.

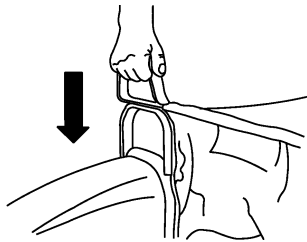

Figure 42

1010

16. Ensure that the bag is taut on the top cloth area between the front bag handle and the rear bag hanger handles. If the bag is too tight or too loose, adjust it as follows:
- Remove the bag from the rear bag hanger.
 - Remove the bolts and knobs securing the hanger clamps to the handle sections (Fig. 40).
 - Assemble the hanger clamps on the handle sections, using whichever set of holes best holds the bag taut.

Note: Using the lower holes tightens the bag assembly and the upper holes loosens the assembly.

17. Connect the spark plug wire.

Note: Under normal use, bag materials are subject to deterioration and wear. Check the grass bag often and replace it when necessary with a genuine Lawn-Boy replacement bag. A weakened or inferior bag may let objects pass through, causing injury.

Installing the Cover Plate

To convert from mulching operation to side discharge the mulch plate must be removed and a cover plate installed.

! **WARNING** !

POTENTIAL HAZARD

- An uncovered discharge opening will allow objects to be thrown in the operator's or bystander's direction. Also, contact with the blade could occur.

WHAT CAN HAPPEN

- Thrown objects or blade contact can cause serious injury.

HOW TO AVOID THE HAZARD

- Never operate the mower unless a cover plate, mulch plate, or grass chute and catcher are installed.

1. Stop the engine and disconnect the spark plug wire (Fig. 7).
2. Remove the wing screw that fastens the mulch plate to the housing (Fig. 35).
3. Slide the mulch plate counterclockwise and pull it up and out of the mower housing.
4. Slide the cover plate over the shoulder bolts (Fig. 43).

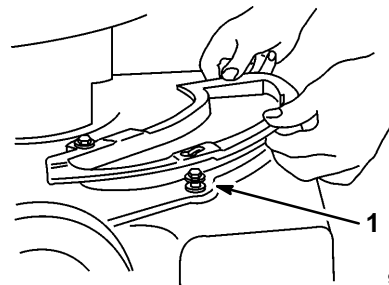

Figure 43

995

1. Shoulder bolt
5. Slide the cover plate clockwise.
6. Secure the cover plate with the wing screw.
7. Connect the spark plug wire (Fig. 7).

Installing the Mulch Plate

To convert from side discharge operation to mulching the cover plate must be removed and the mulch plate installed.



WARNING



POTENTIAL HAZARD

- An uncovered discharge opening will allow objects to be thrown in the operator's or bystander's direction. Also, contact with the blade could occur.

WHAT CAN HAPPEN

- Thrown objects or blade contact can cause serious injury.

HOW TO AVOID THE HAZARD

- Never operate the mower unless a cover plate, mulch plate, or grass chute and catcher are installed.

1. Stop the engine and disconnect the spark plug wire (Fig. 7).
2. Remove the wing screw that fastens the cover plate to the housing (Fig. 35).
3. Slide the cover plate counter clockwise and remove it from the mower housing.
4. Place the front corner of the mulch plate baffle into the deck opening (Fig. 36).
5. Rotate the mulch plate counterclockwise and push it down into the deck opening (Fig. 36).

Note: The mulch plate baffle must go behind the front deck baffle and between the blade and toe guard to prevent contact with the blade.

6. Slide the mulch plate over the shoulder bolts (Fig. 44).
7. Slide the mulch plate clockwise.
8. Secure the mulch plate with the wing screw (Fig. 44).

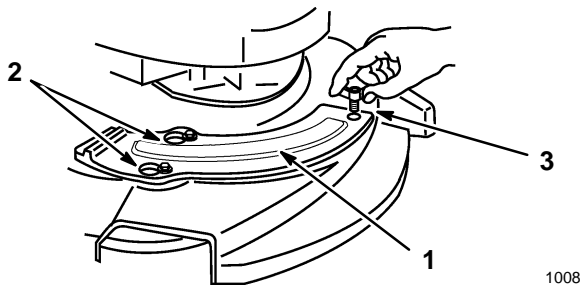

Figure 44

1. Mulch plate
2. Shoulder bolts
3. Wing screw

9. Check the clearance between the blade tips and the baffle, ensuring that there is no contact (Fig. 39).

Note: The baffle must go behind the front deck baffle and between the blade and toe guard to prevent contact with the blade (Fig. 39).

10. Connect the spark plug wire.

Note: Use only a genuine Lawn-Boy replacement cutting blade. Other blades may strike the mulch plate when the engine is started and run.

Mulching Operation

To achieve the best mulching action, set the mower height of cut so that no more than 1/3 of grass stem is cut off; maximum of 1 inch (25 mm) long clippings. If you attempt to mulch more or if the grass is very lush, the mulching action will be poor. Under these conditions it may be beneficial to use the side discharge or grass catcher instead of mulching. A few days later, a pass with the mulch plate installed will put you back on schedule.

Storage

To prepare the mower for off-season storage perform recommended maintenance procedures. Refer to the Maintenance section.

Store the mower in a cool, dry place.

Fuel



WARNING



POTENTIAL HAZARD

- In certain conditions, gasoline is extremely flammable and highly explosive.

WHAT CAN HAPPEN

- A fire or explosion from gasoline can burn you and others and cause property damage.

HOW TO AVOID THE HAZARD

- Do not store gasoline (fuel) over long periods of time.
- To prevent possible explosion of vaporized fuel, do not store the mower with fuel in the tank or carburetor in an enclosure with an open flame (Example: furnace or water heater pilot light).
- Allow the engine to cool before storing in any enclosure.

We recommend Lawn-Boy 2 + 4[®] Fuel Conditioner to stabilize fuel for storage (Fig. 6). If possible, the last fuel fill of the year should be treated with Lawn-Boy 2 + 4[®] Fuel Conditioner.

Plan ahead and try to run the fuel tank empty when mowing the last time prior to storage. The smaller the amount of fuel in the tank, the shorter the time required to run the fuel system dry. Run the mower until engine stops from lack of fuel.

Engine

1. Remove the spark plug.
2. Using an oil can, squirt about one tablespoon of oil through the spark plug hole (Fig. 45).

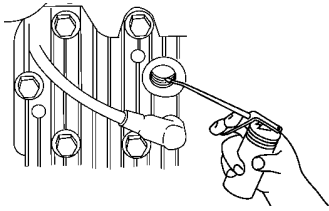

1009

Figure 45

3. Slowly rotate the engine several times, using the starter rope, to distribute the oil (Fig. 10).
4. Replace the spark plug but **do not** connect the spark plug wire.

Folding the Handle

1. Squeeze the bottom handle sections together and slide them past the stops on the handle brackets (Fig. 46).

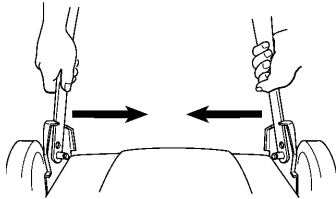

1039

Figure 46

2. Rotate the handle toward the front of the mower (Fig. 47).
3. Loosen the knobs securing the top handle section to the bottom section and fold the top handle section back towards rear of the mower into the storage position (Fig. 47).

Note: When folding the handle, do not allow the cables to get pinched, crimped, or caught on the handle knobs. Fold the handle only in the direction illustrated (Fig. 47).

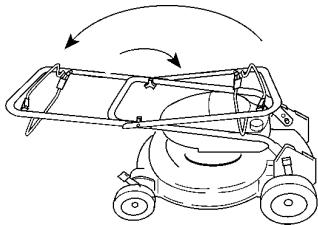

1068

Figure 47

Removing From Storage

1. Unfold the handle. Refer to the handle assembly instructions in the Assembly section
2. Check and tighten all fasteners.
3. Remove the spark plug and spin the engine rapidly using the starter to blow excess oil from the cylinder.
4. Clean the spark plug or replace it if it is cracked, broken, or the electrodes are worn.
5. Install the spark plug and torque it to 180 in-lbs. (15 ft-lbs.) (20 N·m).
6. Perform the recommended maintenance procedures. Refer to the Maintenance section.
7. Fill the fuel tank (Fig. 5) with fresh, clean gasoline/oil mix.
8. Connect the spark plug wire (Fig. 7).



Silver Series WPM
Commercial WPM
Cordless & Electric WPM

THE LAWN-BOY NO-WORRY WARRANTY

A Full Warranty
(Limited Warranty for Commercial Use)

What Is Covered By This Express Warranty?

For a period of 2 years from the date of purchase, Lawn-Boy promises to repair any Lawn-Boy Product used for normal residential purposes* if defective in materials or workmanship or if it stops functioning due to the failure of a component.

The cost of parts and labor is included, but the customer pays the transportation costs.

What Products Are Covered By This Warranty?

This warranty applies to all Gold Series, Silver Series, Commercial Series, Cordless, and Electric Walk Power Mowers.

How About Commercial Use?

Lawn-Boy Walk Power Mowers used for commercial, institutional or rental use are warranted against defects in material or workmanship. Components failing due to normal wear are not covered by this warranty. The following time periods apply from the date of purchase:

Commercial Series Mowers 1 year
All other Lawn-Boy mowers 45 days

How Do You Get Warranty Service?

Should you feel your Lawn-Boy Product requires warranty service, contact the dealer who sold you the product or any Authorized Lawn-Boy Service Dealer. The Yellow Pages of your telephone directory is a good reference source. The dealer will either arrange service at his/her dealership or recommend another Authorized Service Dealer who may be more convenient. You may need proof of purchase (copy of registration card, sales receipt, etc.) for warranty validation.

If for any reason you are dissatisfied with the Service Dealer's analysis of the defect in materials or workmanship or if you need a referral to a Lawn-Boy Service Dealer, please feel free to contact us at the following address:

Lawn-Boy Customer Service Department
8111 Lyndale Avenue South
Bloomington, MN 55420-1196
612-888-8801
800-526-6937

What Must You Do To Keep The Warranty In Effect?

You must maintain your Lawn-Boy Product by following the maintenance procedures described in the operator's manual. Such routine maintenance, whether performed by a dealer or by you, is at your expense.

What Does This Warranty Not Cover? and

How Does Your State Law Relate To This Warranty?

There is no other express warranty except for special emission system coverage on some products. This express warranty does not cover:

- Cost of regular maintenance service or parts, such as filters, fuel, lubricants, oil changes, spark plugs, blade sharpening, blade worn out, cable/linkage adjustments or brake and clutch adjustments.
- Any product or part which has been altered or misused or required replacement or repair due to accidents or lack of proper maintenance.
- Repairs necessary due to improper fuel, contaminants in the fuel system, or failure to properly prepare the fuel system prior to any period of non-use over three months.
- Repairs necessary due to improper battery care, electrical supply irregularities, or failure to properly prepare the mower prior to any period of non-use.
- Pickup and delivery charges.

All repairs covered by this warranty must be performed by an Authorized Lawn-Boy Service Dealer using Lawn-Boy approved replacement parts.

Repair by an Authorized Lawn-Boy Service Dealer is your sole remedy under this warranty.

Lawn-Boy is not liable for indirect, incidental or consequential damages in connection with the use of the Lawn-Boy Products covered by this warranty, including any cost or expense of providing substitute equipment or service during reasonable periods of malfunction or non-use pending completion of repairs under this warranty. Some states do not allow exclusions of incidental or consequential damages, so the above exclusion may not apply to you.

This warranty gives you specific legal rights, and you may also have other rights which vary from state to state.

* Normal residential purposes means mowing the lawn on the same lot as your home. Use at more than one location is considered commercial use and the commercial use warranty would apply.

COUNTRIES OTHER THAN THE UNITED STATES OR CANADA

Customers who have purchased Lawn-Boy Products exported from the United States or Canada should contact their Lawn-Boy Distributor (Dealer) to obtain guarantee policies for your country, province, or state. If for any reason you are dissatisfied with your Distributor's service or have difficulty obtaining guarantee information, contact the Lawn-Boy importer. If all other remedies fail, you may contact us at Lawn-Boy.

Federal Emission Control Warranty Statement

A Two Year Limited Warranty

Your Warranty Rights and Obligations

The U.S. Environmental Protection Agency (EPA) and Lawn-Boy are pleased to explain the emission control system warranty on your 1997 and later utility/lawn/garden equipment engine. 1997 and later model year utility/lawn/garden equipment engines must be designed, built and equipped, at the time of sale, to meet the U.S. EPA regulations for small nonroad engines. The equipment engine must be free from defects in materials and workmanship which cause it to fail to conform with U.S. EPA standards for the first two years of engine use from the date of sale to the ultimate purchaser. Lawn-Boy must warrant the emission control system on your utility/lawn/garden equipment engine for the period of time listed above provided there has been no abuse, neglect or improper maintenance of your utility/lawn/garden equipment engine.

Your emission control system may include parts such as the carburetor or fuel injection system, the ignition system, and catalytic converter. Also included may be hoses, belts, and connectors and other emission related assemblies.

Where a warrantable condition exists, Lawn-Boy will repair your engine at no cost to you including diagnosis, parts and labor.

Manufacturer's Warranty Coverage:

The 1997 and later utility/lawn/garden equipment engines are warranted for two years from the date of delivery. If any emission-related part on your engine is defective in materials or workmanship, the part will be repaired or replaced by Lawn-Boy free of charge.

Owner's Warranty Responsibilities:

- As the engine owner, you are responsible for the performance of the required maintenance listed in your owner's manual. Lawn-Boy recommends that you retain all receipts covering maintenance on your equipment, but Lawn-Boy cannot deny warranty solely for the lack of receipts or for your failure to ensure the performance of all scheduled maintenance.
- Any replacement part or service that is equivalent in performance and durability may be used in non-warranty maintenance or repairs, and shall not reduce the warranty obligations of the engine manufacturer.
- As the engine owner, you should, however, be aware that Lawn-Boy may deny you warranty coverage if your engine or a part has failed due to abuse, neglect, improper maintenance or unapproved modifications or parts.
- You are responsible for presenting your equipment engine to a LAWN-BOY Service Dealer as soon as a problem exists. The warranty repairs should be completed in a reasonable amount of time, not to exceed 30 days.
- If you have any questions regarding your warranty rights and responsibilities or if you need a referral to a Lawn-Boy Service Dealer, please feel free to contact us at the following address:

Lawn-Boy Customer Service Department
8111 Lyndale Avenue South
Bloomington, MN 55420-1196
612-888-8801
800-348-2424

Warranted Parts:

The warranty period begins on the date the engine or equipment is delivered to a retail purchaser. The manufacturer warrants to the initial owner and each subsequent purchaser that the engine is free from defects in materials and workmanship which cause the engine to fail to conform with applicable regulations for a period of two years.

Failures caused by abuse, neglect, or improper maintenance are not covered. The use of add-on or modified parts can be grounds for disallowing a warranty claim. The manufacturer is not liable to cover failures of warranted parts caused by the use of add-on or modified parts. Lawn-Boy is liable for damages to other engine components caused by the failure of a warranted part still under warranty. The owner is responsible for the performance of the required maintenance, as defined by the manufacturer in the written instructions.

Any warranted part which is not scheduled for replacement as required maintenance, or which is scheduled only for regular inspection to the effect of "repair or replace as necessary" shall be warranted for the warranty period. Any warranted part which is scheduled for replacement as required maintenance shall be warranted for the period of time up to the first scheduled replacement point for that part. Coverage under this warranty extends only to the parts listed below (the emissions system parts) to the extent that these parts were present on the engine when purchased.

- Fuel Metering System
 - Cold start enrichment system including the choke mechanism or priming system
 - Fuel pump
 - Air fuel ratio feed back system
 - Carburetor and internal parts
 - Fuel injection system
- Air Induction System
 - Air cleaner
 - Reed intake system
 - Intake manifold
 - Controlled hot air intake system
- Ignition System
 - Spark plug(s)
 - Ignition coils and electronics
 - Advance/retard mechanisms
- Catalytic Converter/Thermal Reactor System
 - Catalytic converter
 - Thermal reactor
 - Exhaust manifold
- Air Injection System
 - Air injection system or pulse valve
 - Valves affecting distribution of air
- Exhaust Gas Recirculation (EGR) System
 - EGR valve body and piping system connecting to the intake side of the engine
 - EGR control system
- Particulate Controls
 - Traps filters, precipitators and any other device used to capture particulate emissions
- Miscellaneous Items Used in the Above Systems
 - Vacuum, temperature, and time sensitive valves and switches
 - Electronic controls
 - Hoses, connectors, and assemblies of same

How to Get Warranty Service:

Should you feel your Lawn-Boy Product requires warranty service, contact the dealer who sold you the product or any Authorized Lawn-Boy Service Dealer or Lawn-Boy Master Service Dealer. The Yellow Pages of your telephone directory is a good reference source. The dealer will either arrange service at his/her dealership or recommend another Authorized Service Dealer who may be more convenient. You may need proof of purchase (copy of registration card, sales receipt, etc.) for warranty validation. The owner shall not be charged for diagnostic labor which leads to the determination that a warranted part is defective, if the diagnostic work is performed at a warranty station.

The Lawn-Boy Company is not liable for indirect, incidental or consequential damages in connection with the use of the Lawn-Boy Products covered by this warranty, except for damages to other engine components caused by the failure of a warranted part still under warranty. Some states do not allow exclusions of incidental or consequential damages, so the above exclusion may not apply to you.

This warranty gives you specific legal rights, and you may also have other rights which vary from state to state.