



Count on it.

Parts Catalog

**Stump Grinder
Compact Tool Carrier**

Model No. 22429—Serial No. 404320000 and Up



Ordering Replacement Parts

To order replacement parts, please supply the part number, the quantity, and the description of each part desired.

Understanding Reference Numbers

Each identified part in an illustration has a reference number. The reference number for a part also appears in the parts list, along with other information about the part.

This catalog uses two special reference number formats, one to indicate parts in a service assembly and another to indicate the quantity of a given part in an illustration.

Service Assembly Reference Numbers

Parts in service assemblies have reference numbers in the form a:b. The a represents the reference number of the entire service assembly and the b represents a sequential number unique to each part within the service assembly.

For example, a wheel assembly might be identified by reference number 6, the tire by 6:1, the valve by 6:2, and the wheel by 6:3. When you order the assembly identified by reference number 6, you receive all parts identified by reference numbers 6:1, 6:2, and 6:3. However, you may also order any part individually. Reference numbers of this type appear in illustration and in parts lists.

Reference Numbers Indicating Quantity

In an illustration, if a reference number indicates more than one part, the reference number has the form nX y. The n represents the quantity of the part, the X is the multiplication symbol, and the y represents the reference number.

For example, in an illustration, the reference number 2X 37 means that two of the parts identified by reference number 37 are indicated.

Contents

Grinder Frame, Head and Hydraulic Motor Assembly 4
Hydraulic Motor Assembly No. 127-9603..... 6
Shield and Guard Assembly 8

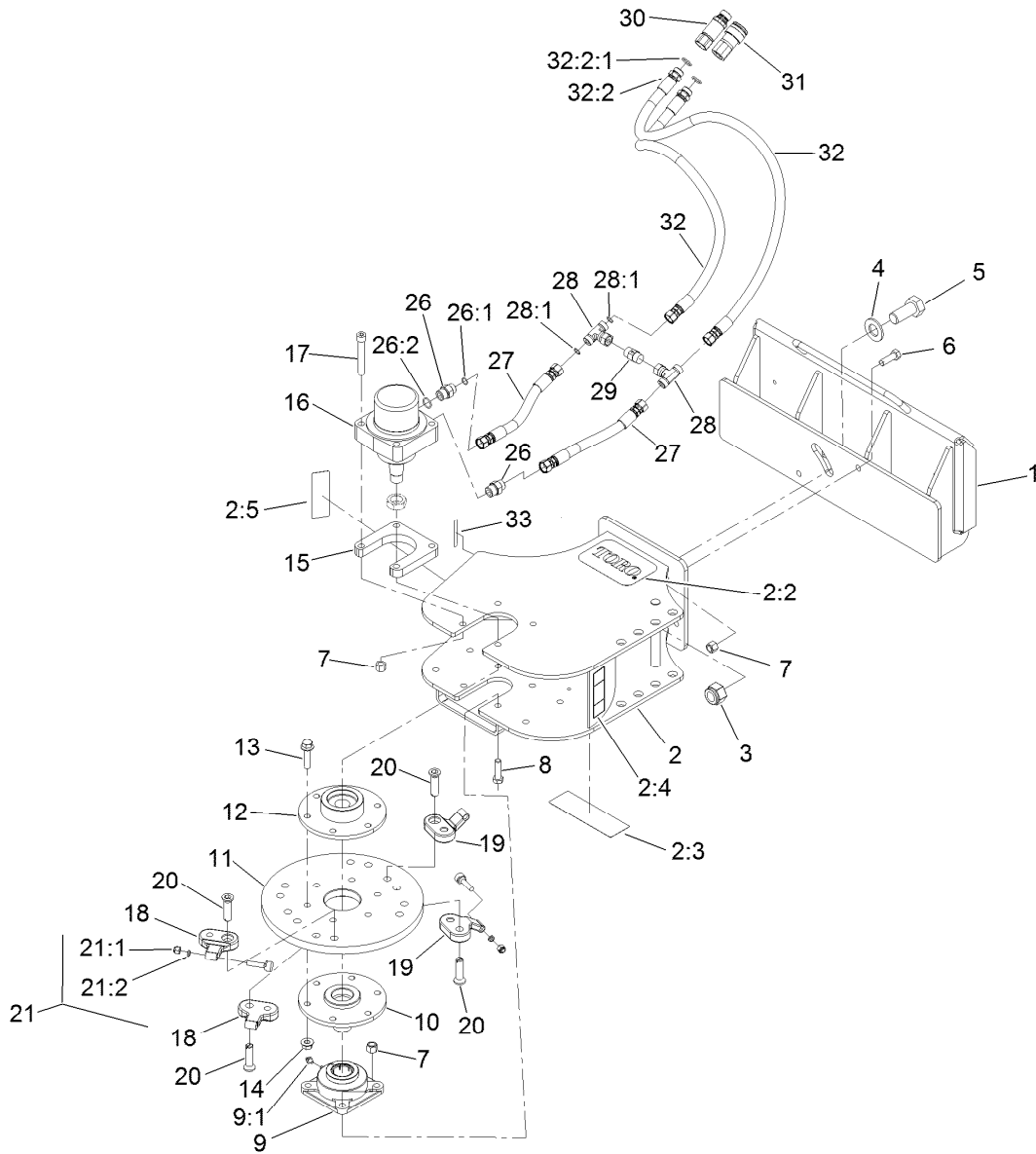

Grinder Frame, Head and Hydraulic Motor Assembly

Ref.	Part Number	Qty.	Description
1	132-8629-03	1	Plate-Attach, Quick
2	136-4516	1	Grinder Frame ASM
2:2	93-7340	1	Decal
2:3	136-5814	1	Decal-Safety, Grinder
2:4	136-5818	1	Decal-Warning
2:5	136-5817	1	Decal-Danger
3	104-2024	1	Nut-Hex, NI
4	3256-62	1	Washer-Flat
5	104-2035	1	Screw-Cap
6	325-6	2	Screw-HH
7	3296-23	10	Nut-Lock, NI
8	325-7	4	Screw-HH
9	104-2026	1	Bearing
9:1	302-2	1	Fitting-Grease
10	115-9395-03	1	Shaft-Stub
11	136-4501-03	1	Wheel-Grinder, Stump
12	119-4570-03	1	Hub-Drive
13	3234-27	6	Screw-HHF

Ref.	Part Number	Qty.	Description
14	32128-49	6	Nut-HHF
15	136-4502-03	1	Plate- Spacer
16	127-9603	1	HYD Motor ASM
17	3274-100	4	Screw-HSH
18	115-9388	4	Pocket-Straight
19	115-9384	8	Pocket-Angled
20	115-9386	12	Bolt-HSH, RH
21	115-9385	12	Grinder Tooth ASM
21:1	3296-39	1	Nut-Lock, NI
21:2	121-4365	1	Spacer-Tooth
26	340-6	2	Fitting-Straight
26:1	237-30	1	O-Ring
26:2	237-80	1	O-Ring
27	95-3664	2	HYD Hose ASM
28	93-6810	2	Fitting-Tee
28:1	237-30	2	O-Ring
29	117-6383	1	Valve-Check
30	100-4701	1	Nipple-Connect, Pressure

● Not illustrated

■ Not serviced separately

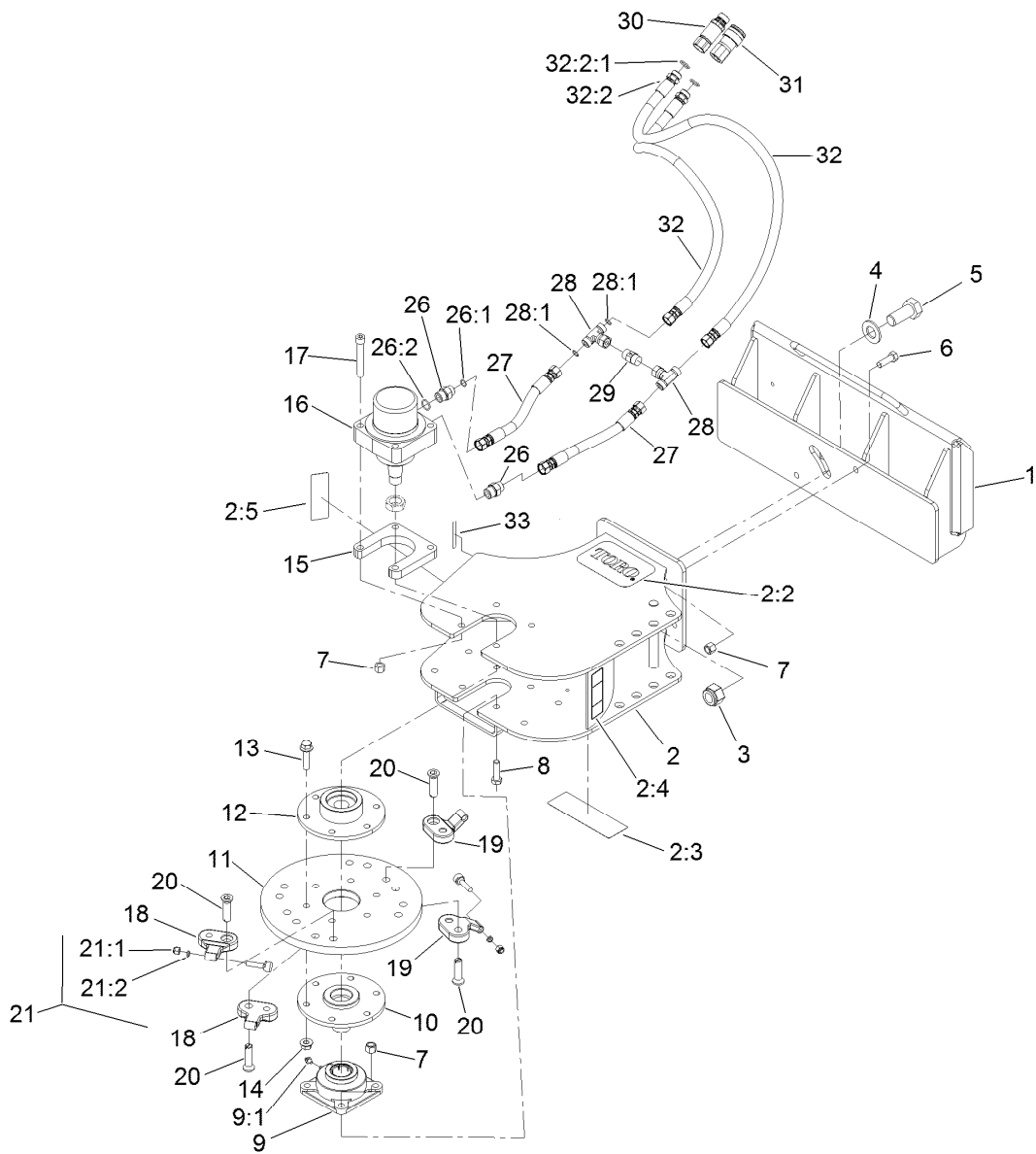

Grinder Frame, Head and Hydraulic Motor Assembly (continued)

Ref.	Part Number	Qty.	Description
30:1	100-6120	1	Seal Kit ●
31	104-6134	1	Coupler-Face, Flush
32	136-5805	2	HYD Hose ASM

Ref.	Part Number	Qty.	Description
32:2		1	Fitting-Straight ■
32:2:1	237-80	1	O-Ring
33	133-8061	1	Decal-Warning

● Not illustrated

■ Not serviced separately

Hydraulic Motor Assembly No. 127-9603

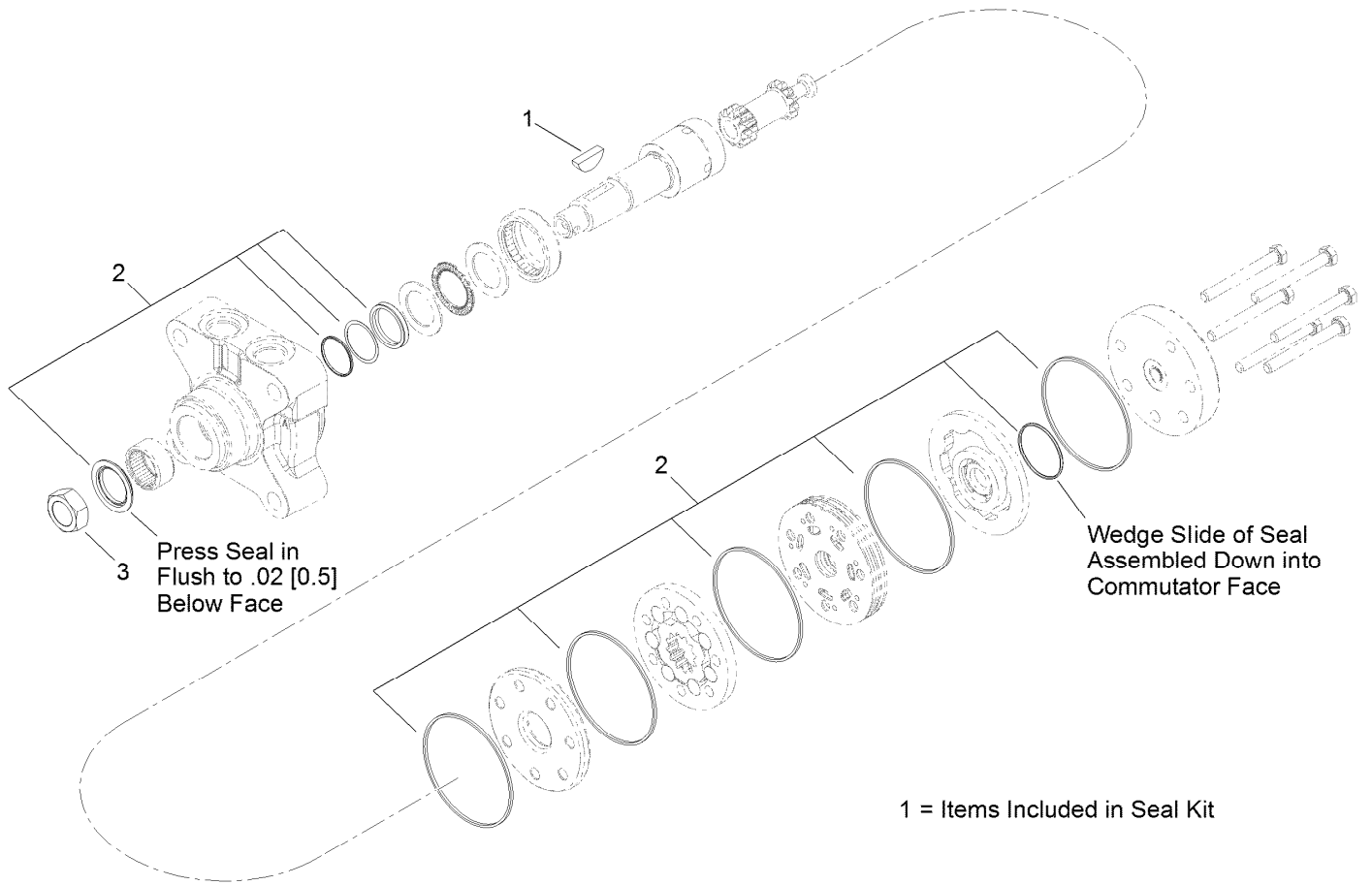

Hydraulic Motor Assembly No. 127-9603 (continued)

<i>Ref.</i>	<i>Part Number</i>	<i>Qty.</i>	<i>Description</i>
1	3257-42	1	Key-Woodruff
2	119-4631	1	Seal Kit
3	106-8159	1	Nut-Lock

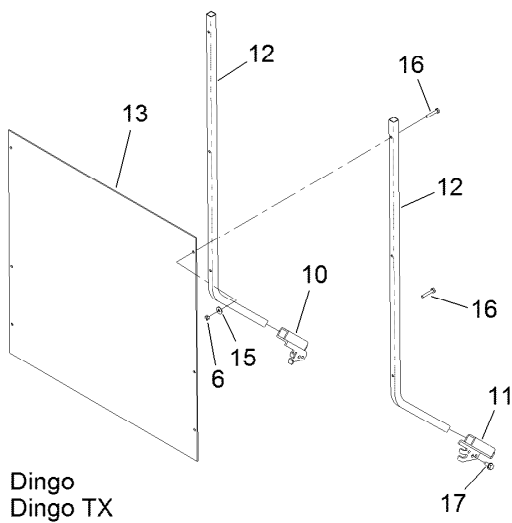

Dingo
Dingo TX

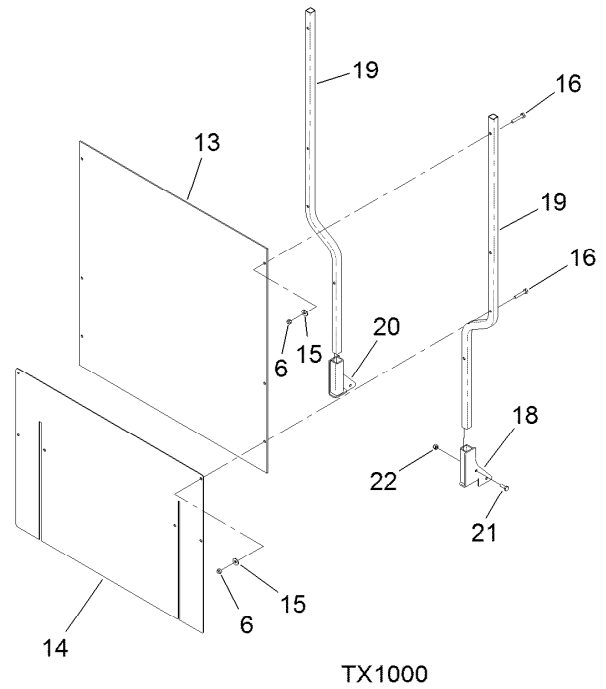

TX1000

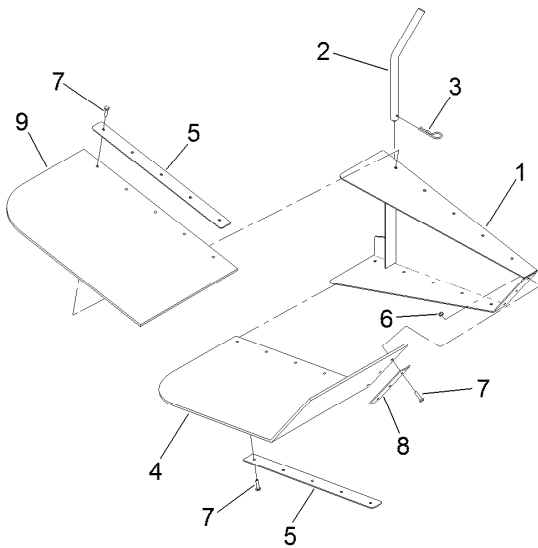

Shield and Guard Assembly

Ref.	Part Number	Qty.	Description
1	104-2012-03	1	Chipper Guard ASM
2	104-2018	1	Pin-Hinge
3	3290-343	1	Pin-Hair
4	104-2022	1	Guard-Skirt, Rear
5	104-2019-03	2	Clamp-Skirt
6	3296-8	21	Nut-Hex
7	321-6	13	Screw-HH
8	104-2021-03	1	Clamp-Skirt
9	104-2023	1	Guard-Skirt, Front
10	104-5818-03	1	Bracket-Support, RH
11	104-5817-03	1	Bracket-Support, LH

Ref.	Part Number	Qty.	Description
12	104-5815-03	2	Support-Shield
13	136-4553	1	Shield-Lexan
14	136-4554	1	Skirt-Protector
15	3256-78	8	Washer-Flat
16	321-9	8	Screw-HH
17	32144-70	4	Screw-HWHTF
18	132-8623-03	1	Bracket-Support, LH
19	136-4558-03	2	Support-Tube, Shield
20	132-8624-03	1	Bracket-Support, RH
21	321-4	4	Screw-HH
22	3296-42	4	Nut-Lock, NI

Notes:

Notes:

Notes:



Count on it.