



Count on it.

Parts Catalog

**High-Torque Trencher Head
Compact Tool Carrier**

Model No. 22473—Serial No. 404310000 and Up



Ordering Replacement Parts

To order replacement parts, please supply the part number, the quantity, and the description of each part desired.

Understanding Reference Numbers

Each identified part in an illustration has a reference number. The reference number for a part also appears in the parts list, along with other information about the part.

This catalog uses two special reference number formats, one to indicate parts in a service assembly and another to indicate the quantity of a given part in an illustration.

Service Assembly Reference Numbers

Parts in service assemblies have reference numbers in the form a:b. The a represents the reference number of the entire service assembly and the b represents a sequential number unique to each part within the service assembly.

For example, a wheel assembly might be identified by reference number 6, the tire by 6:1, the valve by 6:2, and the wheel by 6:3. When you order the assembly identified by reference number 6, you receive all parts identified by reference numbers 6:1, 6:2, and 6:3. However, you may also order any part individually. Reference numbers of this type appear in illustration and in parts lists.

Reference Numbers Indicating Quantity

In an illustration, if a reference number indicates more than one part, the reference number has the form nX y. The n represents the quantity of the part, the X is the multiplication symbol, and the y represents the reference number.

For example, in an illustration, the reference number 2X 37 means that two of the parts identified by reference number 37 are indicated.

Contents

High-Torque Trencher Head Assembly 4
High Torque Hydraulic Motor Assembly No. 107-9350. 6
Attachments and Accessories 7

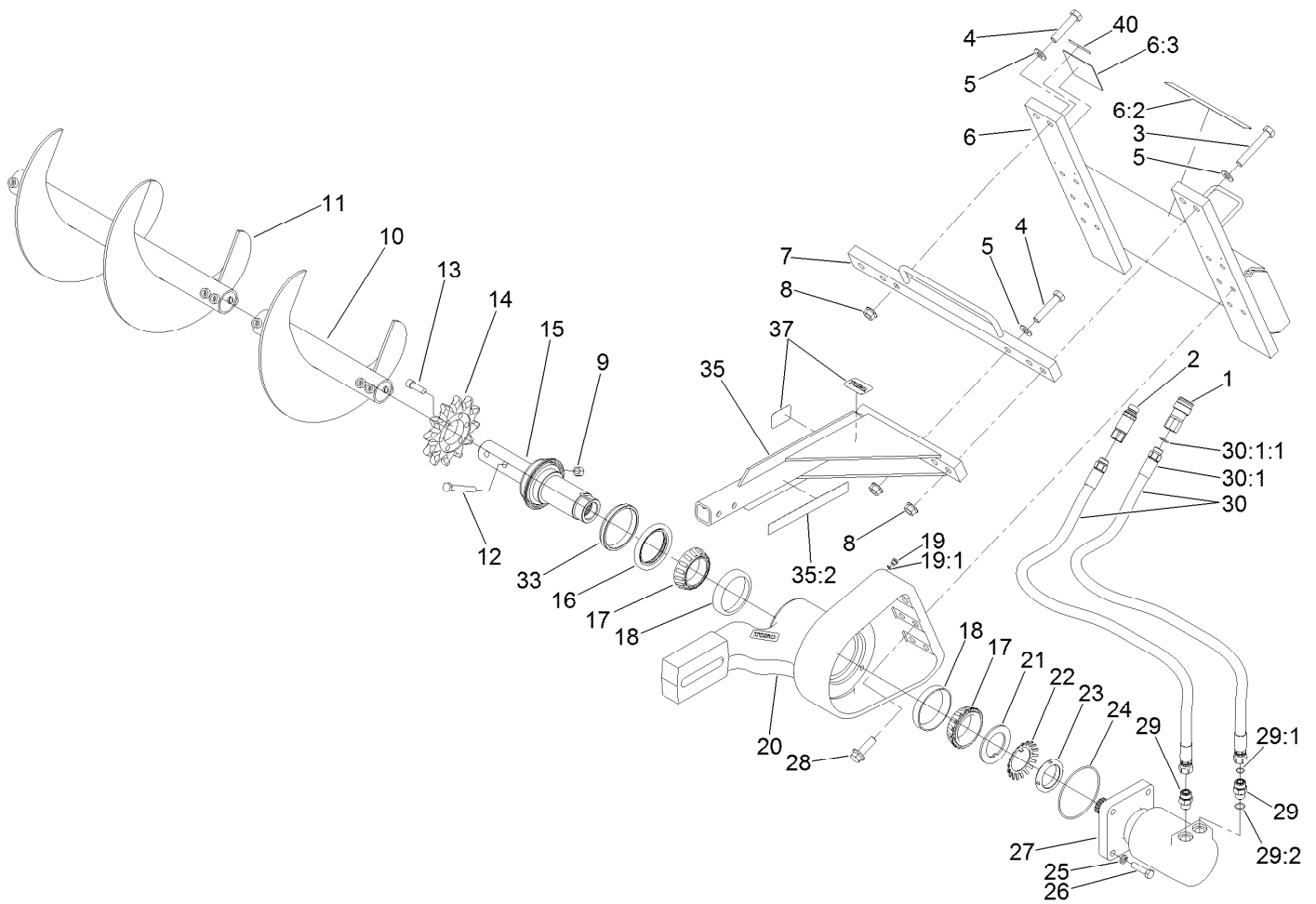

High-Torque Trencher Head Assembly

Ref.	Part Number	Qty.	Description	Ref.	Part Number	Qty.	Description
1	104-6134	1	Coupler-Face, Flush	16	104-1967	1	Seal-Shaft
2	100-4701	1	Nipple-Connect, Pressure	17	104-1966	2	Cone-Bearing
2:1	100-6120	1	Seal Kit ●	18	104-1965	2	Cup-Bearing
3	104-5877	2	Screw-HH	19	353-990	1	Plug ASM
4	104-5895	3	Screw-HH	19:1	237-78	1	O-Ring
5	3256-27	5	Washer-Flat	20	104-1931-03	1	Mount-Boom
6	104-1938	1	Mount ASM	21	104-1972	1	Washer-Tongued
6:2	99-9952	1	Decal-Danger	22	104-5915	1	Washer-Lock, Bearing
6:3	99-9953	1	Decal-Danger	23	104-1973	1	Nut-Lock, Bearing
7	104-5894-03	1	Crossbar ASM	24	104-1920	1	O-Ring
8	32128-50	5	Nut-Flange	25	3253-7	4	Washer-Lock
9	3296-23	1	Nut-Lock, NI	26	325-8	4	Screw-HH
10	104-5912-03	1	Auger ASM	27	107-9350	1	Motor-HYD, High Torque
11	117-3433-03	1	Auger ASM ■	28	104-5870	6	Screw
12	325-35	1	Screw-HH	29	340-7	2	Fitting-Straight
13	3274-4	6	Sprocket-Trencher	29:1	237-65	1	O-Ring
14	104-1964	1	Sprocket-Trencher	29:2	237-80	1	O-Ring
15	104-1969	1	Shaft-Trencher	30	104-1932	2	Hose ASM

● Not illustrated
▲ Not serviced separately

■ Optional Equipment

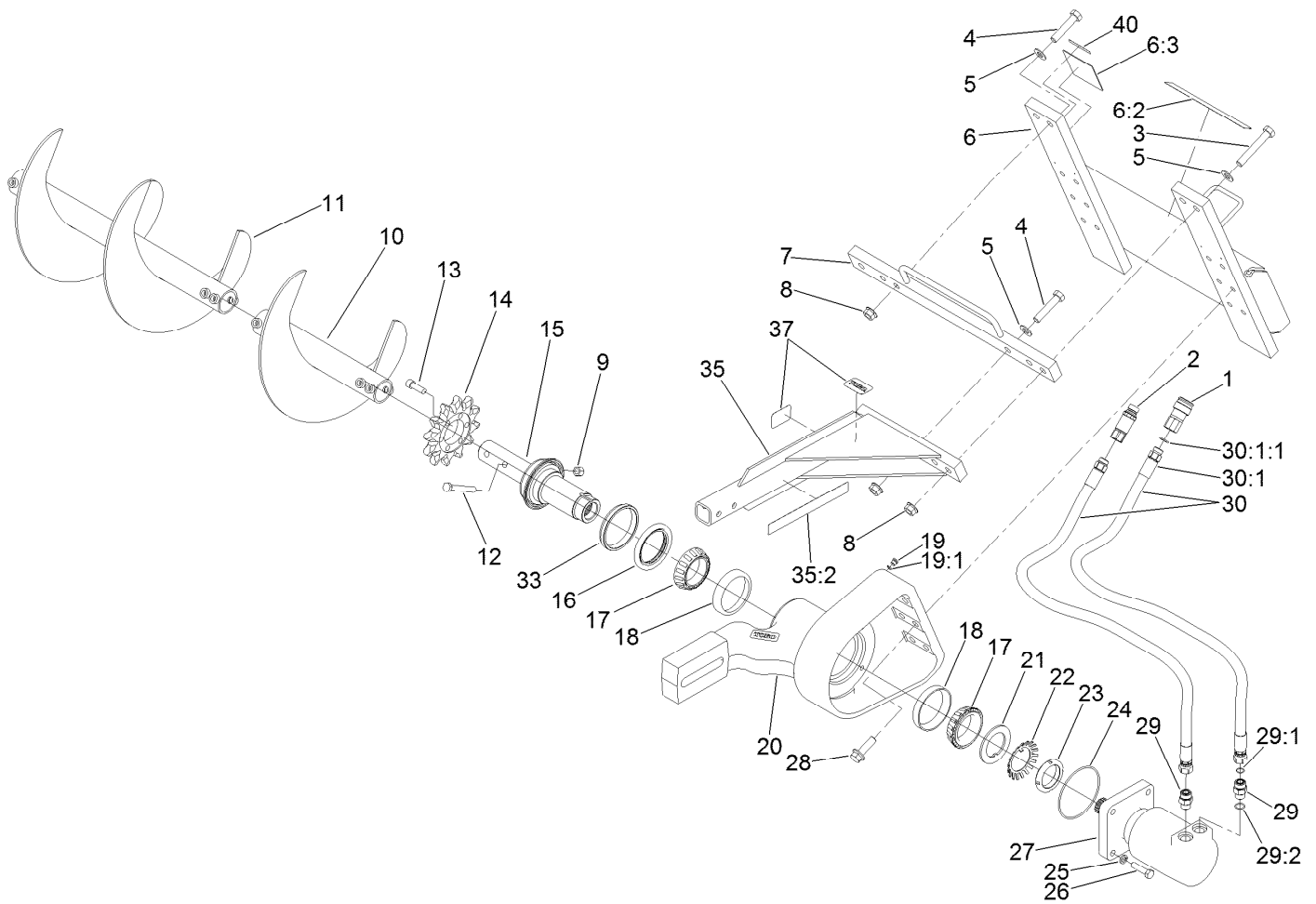

High-Torque Trencher Head Assembly (continued)

Ref.	Part Number	Qty.	Description	Ref.	Part Number	Qty.	Description
30:1		1	Fitting-Straight ▲	35:2	99-9952	2	Decal-Danger
30:1:1	237-80	1	O-Ring	37	98-3206	2	Decal
33	104-5935	1	Spacer	40	133-8061	1	Decal-Warning
35	117-3444	1	Safety Rail ASM				

● Not illustrated
▲ Not serviced separately

■ Optional Equipment

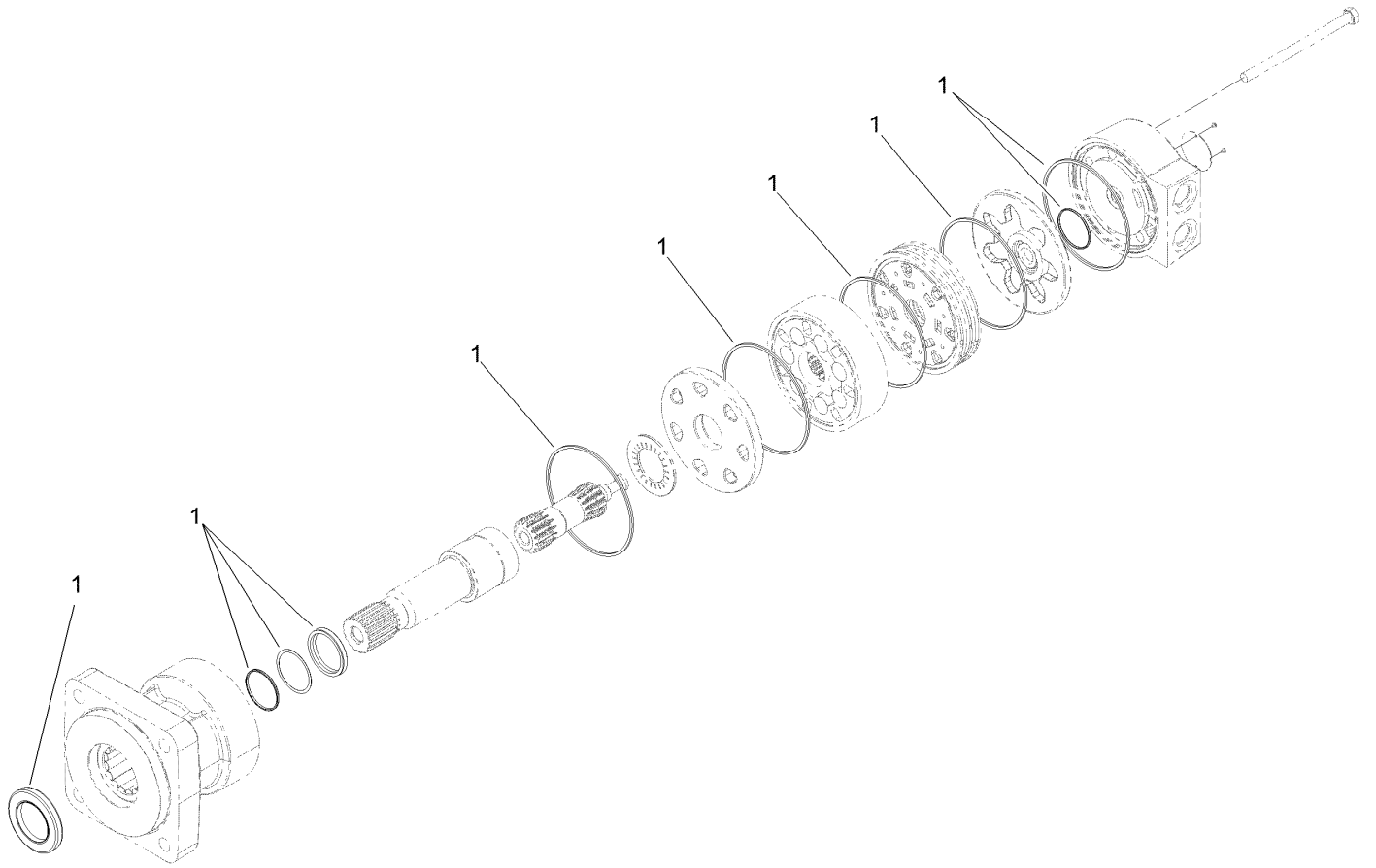

High Torque Hydraulic Motor Assembly No. 107-9350

<i>Ref.</i>	<i>Part Number</i>	<i>Qty.</i>	<i>Description</i>
1	107-9368	1	Seal Kit

Attachments and Accessories

For 22473 High-Torque Trencher Head Compact Tool Carrier

Product Name	Model/Part
Crumber Kit	22477
24in X 4in Soil Chain.....	22480
24in X 4in Combination Chain	22481
24in X 4in Rock Tooth Chain.....	22482
24in X 6in Soil Chain.....	22483
24in X 6in Combination Chain	22484
24in X 6in Rock Tooth Chain.....	22485
36in X 4in Soil Chain.....	22486
36in X 4in Combination Chain	22487
36in X 4in Rock Tooth Chain.....	22488
36in X 6in Rock Tooth Chain.....	22489
36in X 6in Soil Chain.....	22490
36in X 6in Combination Chain	22491
48in x 4in Soil Chain	22492
48in x 4in Combination Chain	22493
48in x 6in Soil Chain	22494
48in x 6in Combination Chain	22495
24in Trencher Boom	22975
36in Trencher Boom	22976
48in Trencher Boom	22977



Count on it.