



Count on it.

Operator's Manual

LT3340 Heavy-Duty Triple Turf Mower Traction Unit

Model No. 30657—Serial No. 40000000 and Up



g014494



This product complies with all relevant European directives. For details, please see the separate product specific Declaration of Conformity (DOC) sheet.

Introduction

This machine is a ride-on, reel-blade lawn mower intended to be used by professional, hired operators in commercial applications. It is primarily designed for cutting grass on well-maintained turf. Using this product for purposes other than its intended use could prove dangerous to you and bystanders.

Read this information carefully to learn how to operate and maintain your product properly and to avoid injury and product damage. You are responsible for operating the product properly and safely.

Visit www.Toro.com for more information, including safety tips, training materials, accessory information, help finding a dealer, or to register your product.

Whenever you need service, genuine Toro parts, or additional information, contact an Authorized Service Dealer or Toro Customer Service and have the model and serial numbers of your product ready. [Figure 1](#) identifies the location of the model and serial numbers on the product. Write the numbers in the space provided.

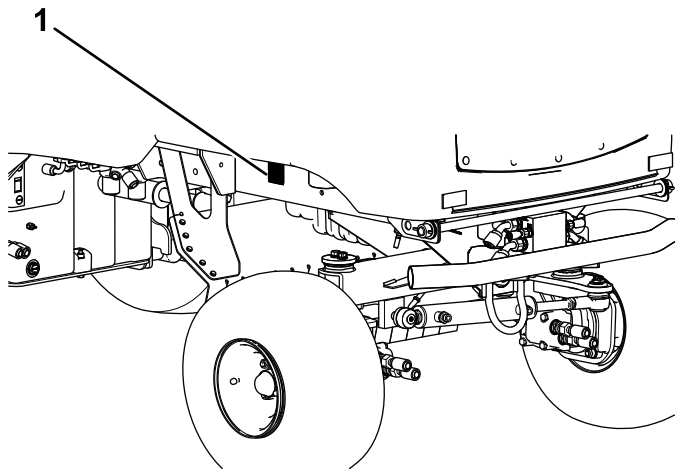

Figure 1

g281378

1. Location of the model and serial numbers

Model No. _____
Serial No. _____

This manual identifies potential hazards and has safety messages identified by the safety alert symbol ([Figure 2](#)), which signals a hazard that may cause serious injury or death if you do not follow the recommended precautions.



Figure 2

Safety-alert symbol

g000502

This manual uses 2 words to highlight information. **Important** calls attention to special mechanical information and **Note** emphasizes general information worthy of special attention.

Contents

Safety	4	Checking the Fuel Lines and Connections.....	36
General Safety.....	4	Bleeding the Fuel System.....	36
Safety and Instructional Decals	4	Replacing the Fuel Filter	36
Setup	8	Electrical System Maintenance	37
Product Overview	8	Electrical System Safety	37
Controls	9	Checking the Electrical System.....	37
Specifications	16	Checking the Battery Condition.....	37
Attachments/Accessories	16	Servicing the Battery.....	38
Before Operation	17	Drive System Maintenance	38
Before Operation Safety	17	Checking the Tire Pressure.....	38
Performing Daily Maintenance.....	17	Checking the Torque of the Wheel Nuts	38
Filling the Fuel Tank.....	17	Changing the Transmission Oil Filter	38
During Operation	18	Checking the Rear Wheel Alignment.....	39
During Operation Safety	18	Inspecting the Transmission Control Cable and Operating Mechanism	39
Using the Operator Platform Latching Mechanism	19	Cooling System Maintenance	40
Understanding the Operator Presence Controls	20	Cooling System Safety	40
Folding the Roll Bar	20	Removing Debris from the Cooling System.....	40
Checking the Interlock Switches	21	Belt Maintenance	42
Starting the Engine	22	Tensioning the Alternator Belt	42
Shutting Off the Engine.....	22	Hydraulic System Maintenance	42
Using the Grass Deflectors	23	Hydraulic System Safety.....	42
Adjusting the Center Cutting Unit Height-of-Cut Correction	23	Checking the Hydraulic Lines and Hoses.....	42
Controlling the Position of the Individual Cutting units.....	23	Checking the Hydraulic Fluid	42
Adjusting the Cutting Unit Auto Limited Lift.....	23	Changing the Hydraulic Return Filter	43
Engaging the Cutting Unit Drive.....	24	Servicing the Hydraulic System	44
Clearing the Cutting Units	24	Checking the Hydraulic Fluid Overheat Warning System.....	44
Using Weight Transfer / Traction Assistance	25	Checking the Hydraulic Lines and Hoses.....	45
Operating Tips	25	Cutting Unit Maintenance	45
After Operation	26	Blade Safety	45
After Operation Safety	26	Back Lapping the Cutting Units	45
Identifying the Tie-Down Points	26	Grinding the Cutting Units	46
Hauling the Machine	27	Cleaning	47
Locating the Jacking Points	27	Washing the Machine	47
Towing the Machine	27	Storage	47
Maintenance	29	Storage Safety.....	47
Maintenance Safety.....	29	Preparing the Traction Unit	47
Recommended Maintenance Schedule(s)	29	Preparing the Engine	47
Daily Maintenance Checklist.....	31	Troubleshooting	49
Lubrication	32		
Greasing the Bearings, Bushings, and Pivots.....	32		
Engine Maintenance	33		
Engine Safety	33		
Checking the Engine Overheat Warning System.....	33		
Servicing the Air Cleaner	33		
Checking the Engine-Oil Level.....	34		
Servicing the Engine Oil and Filter	35		
Fuel System Maintenance	36		
Draining the Fuel Tank.....	36		

Safety

This machine has been designed in accordance with EN ISO 5395.

General Safety

This product is capable of amputating hands and feet and of throwing objects.

- Read and understand the contents of this *Operator's Manual* before starting the engine.
- Use your full attention while operating the machine. Do not engage in any activity that causes distractions; otherwise, injury or property damage may occur.
- Do not put your hands or feet near moving components of the machine.

- Do not operate the machine without all guards and other safety protective devices in place and functioning properly on the machine.
- Keep children, bystanders, and pets out of the operating area. Never allow children to operate the machine.
- Shut off the engine, remove the key, wait for all movement to stop before you leave the operator's position. Allow the machine to cool before adjusting, servicing, cleaning, or storing it.

Improperly using or maintaining this machine can result in injury. To reduce the potential for injury, comply with these safety instructions and always pay attention to the safety-alert symbol , which means Caution, Warning, or Danger—personal safety instruction. Failure to comply with these instructions may result in personal injury or death.

Safety and Instructional Decals



Safety decals and instructions are easily visible to the operator and are located near any area of potential danger. Replace any decal that is damaged or missing.

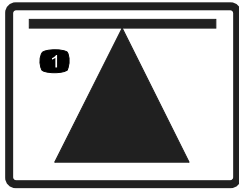

70-13-072

decal70-13-072

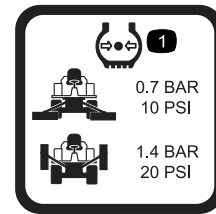

950832

decal950832

1. Jacking point

1. Tire pressure

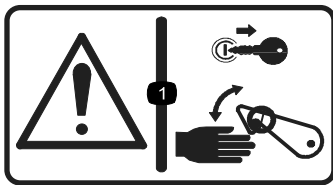

70-13-077

decal70-13-077

1. Warning—shut off the engine and remove the ignition key before releasing or operating the safety latches.



950889

decal950889

1. Warning—hot surfaces.

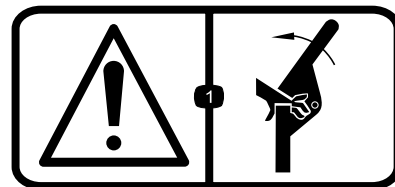

111-0773

decal111-0773

1. Warning—crushing of fingers, force applied from side.

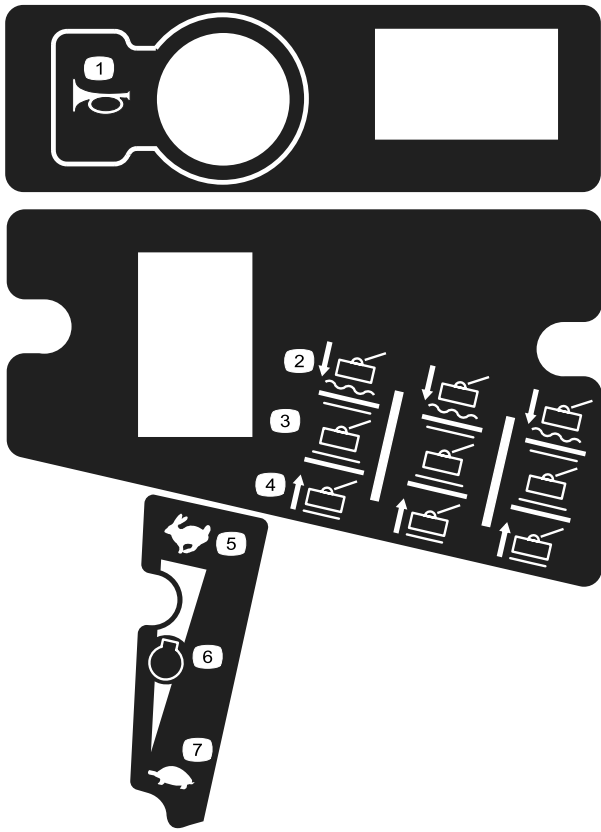

111-3277

decal111-3277

- | | |
|------------------------------|-----------------|
| 1. Horn | 5. Fast |
| 2. Cutting units—lower/float | 6. Engine speed |
| 3. Cutting units—hold | 7. Slow |
| 4. Cutting units—raise | |



111-3562

decal111-3562

1. Press the pedal to adjust the steering wheel angle.

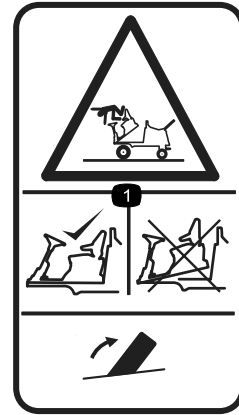

111-3566

decal111-3566

1. Falling, crushing hazard—ensure that the operator platform latch is engaged before operating.

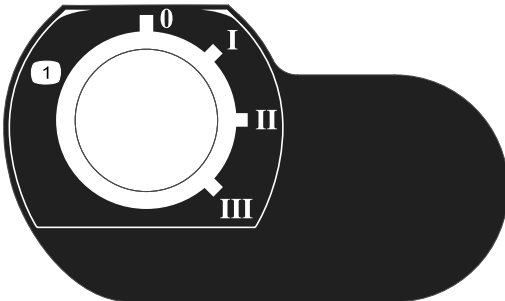

111-3344

decal111-3344

1. Ignition switch

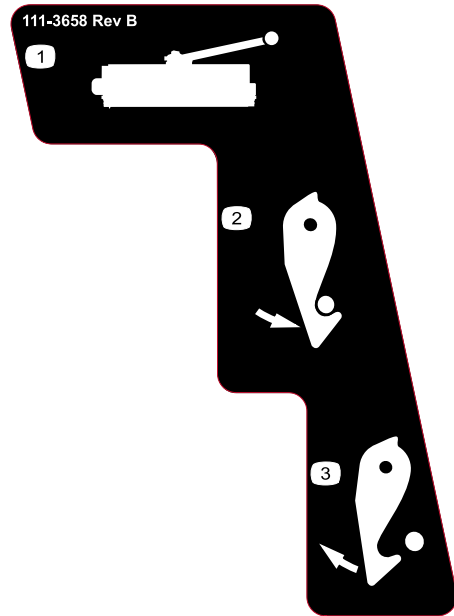

111-3658

decal111-3658

- | | |
|---------------|------------|
| 1. Cutterhead | 3. Unlatch |
| 2. Latch | |

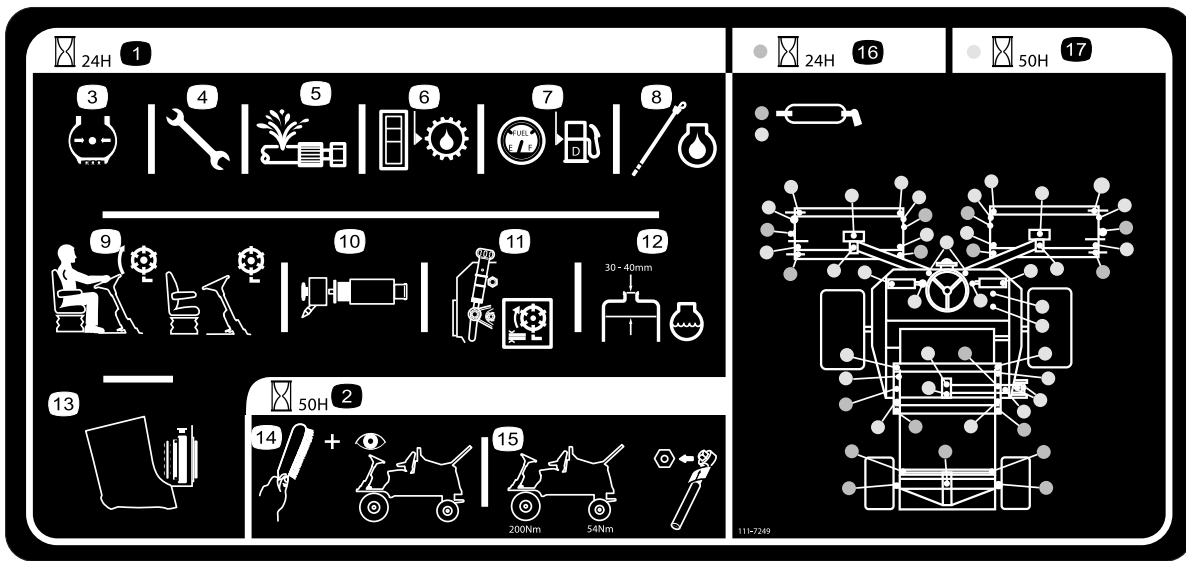

decal111-7249

111-7249

- | | | | |
|--|-----------------------------------|--|---|
| 1. Daily service interval | 6. Check hydraulic fluid level | 11. Check cutting unit setting | 16. Lubrication points for daily interval |
| 2. 50 hour service interval | 7. Check fuel level | 12. Check engine coolant level | 17. Lubrication points for 50 hour interval |
| 3. Check the tire pressure | 8. Check engine oil level | 13. Check cleanliness of radiator | |
| 4. Check all nuts and bolts for proper tightness | 9. Check operation of seat switch | 14. Clean and inspect the machine | |
| 5. Check all hoses for leaks | 10. Check air filter element | 15. Check wheel nut tightness using a torque wrench—front wheels 200 N·m, rear wheels 54 N·m | |



decal111-3567

111-3567

1. Pedal operation



decal111-3902

111-3902

1. Your hand can be cut by the fan; warning
2. Hot surfaces; read the *Operator's Manual*.

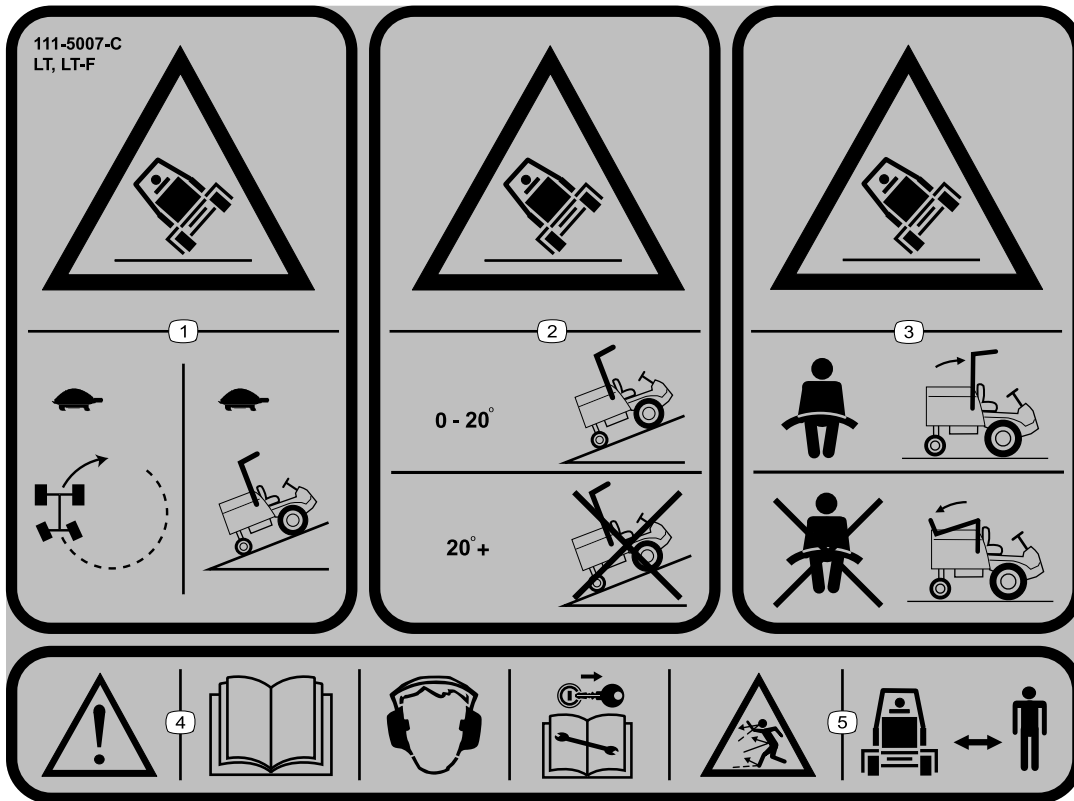

decal111-5007

111-5007

Note: This machine complies with the industry standard stability test in the static lateral and longitudinal tests with the maximum recommended slope indicated on the decal. Review the instructions for operating the machine on slopes in the *Operator's Manual* as well as the conditions in which you would operate the machine to determine whether you can operate the machine in the conditions on that day and at that site. Changes in the terrain can result in a change in slope operation for the machine. If possible, keep the cutting units lowered to the ground while operating the machine on slopes. Raising the cutting units while operating on slopes can cause the machine to become unstable.

1. Tipping hazard—drive slowly when turning or going up slopes.
2. Tipping hazard—only drive up slopes that are between 0 and 20°; do not drive up slopes that are greater than 20°.
3. Tipping hazard—wear a seatbelt when the rollbar is up; do not wear a seatbelt when the rollbar is down.
4. Warning—read the *Operator's Manual*; wear hearing protection; remove the key before performing any maintenance.
5. Thrown object hazard—keep bystanders away.



decal111-3901

111-3901

1. Transmission fluid—read the *Operator's Manual* for more information.

Setup

Media and Additional Parts

Description	Qty.	Use
Operator's Manual	1	Read the manuals before operating the machine.
Engine operator's manual	1	
CE certificate	1	The certificate indicates CE compliance.

Store all documentation in a safe place for future use.

Note: Determine the left and right sides of the machine from the normal operating position.

Product Overview

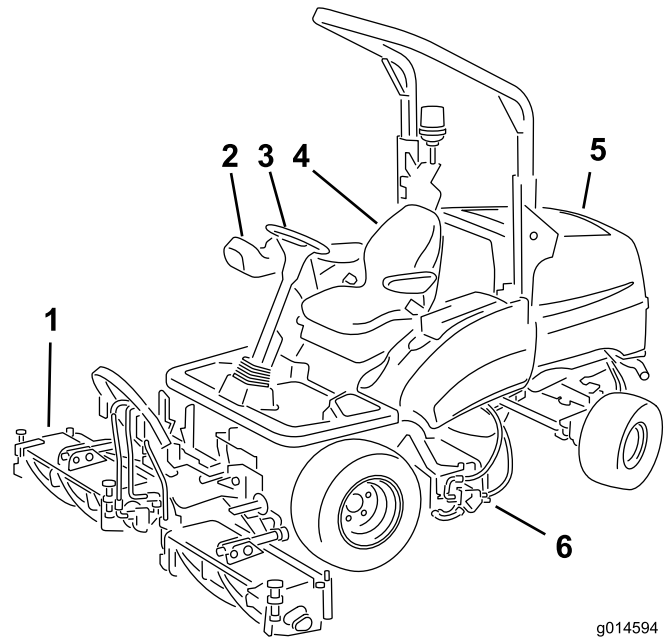

Figure 3

- | | |
|------------------------|----------------------|
| 1. Front cutting units | 4. Operator's seat |
| 2. Control arm | 5. Engine hood |
| 3. Steering wheel | 6. Rear cutting unit |

Controls

Control Panel Components

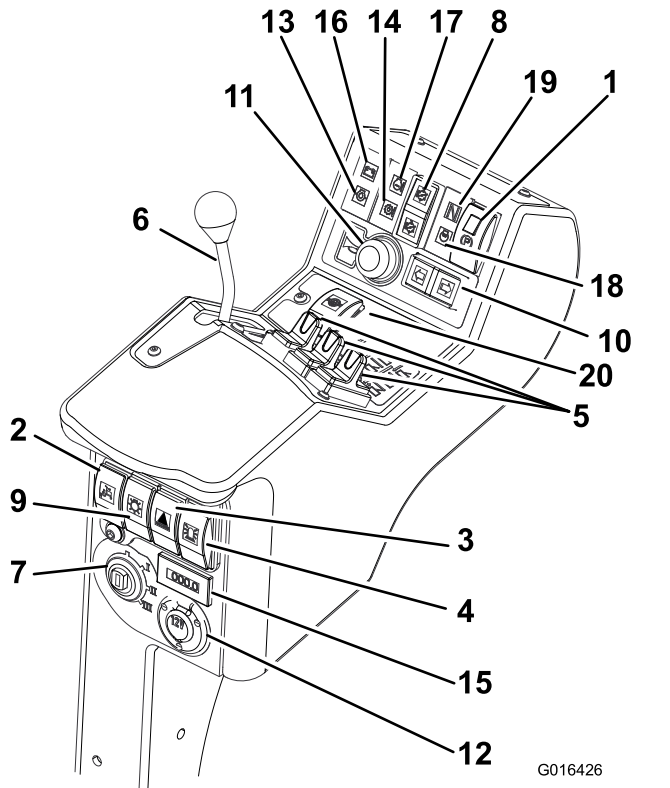

Figure 4

G016426
g016426

- | | |
|---|--|
| 1. Parking brake switch | 11. Horn button |
| 2. Limited lift in reverse switch | 12. Auxiliary 12 volt socket (supplied with a 12V kit) |
| 3. Hazard warning switch (supplied with lighting kit) | 13. Engine oil pressure indicator |
| 4. Warning beacon switch (supplied with beacon kit) | 14. Transmission temperature indicator |
| 5. Cutting units position controls | 15. Hour meter |
| 6. Throttle control lever | 16. Battery warning indicator |
| 7. Ignition switch | 17. Engine temperature warning indicator |
| 8. Cutting unit drive switch | 18. Glow plug indicator |
| 9. Lighting switch (supplied with lighting kit) | 19. Transmission neutral indicator |
| 10. Direction indicator switch (supplied with lighting kit) | 20. Differential lock switch |

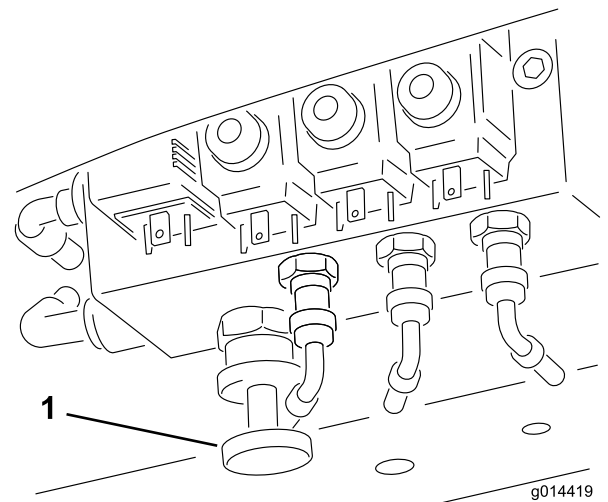

Figure 5

g014419
g014419

1. Weight transfer control

Braking System

Parking Brake

Move the parking brake switch to the forward position by pressing the smaller locking button and moving the switch forward to engage the parking brake (Figure 6).

Note: Do not operate the mower with the parking brake engaged and do not engage the parking brake while the mower is moving.

This light illuminates when the parking brake is engaged and the ignition key is turned to position I.

⚠ WARNING

The parking brake operates on the front wheels only. Do not park the mower on a slope.

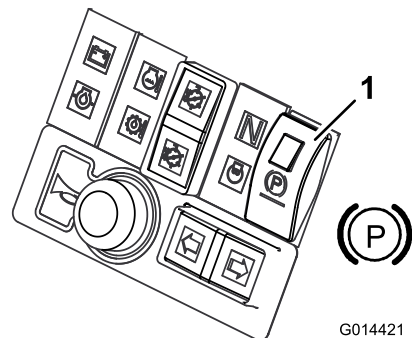

Figure 6

G014421
g014421

1. Parking brake

Service Brake

Service braking is achieved by the hydraulic transmission system. When the forward or reverse travel pedals are released or the engine speed is reduced, service braking becomes effective and travel speed is automatically reduced. To increase the braking effect, push the transmission pedal into the neutral position. Service braking is effective on the front wheels only.

⚠ WARNING

The service braking system will not hold the mower at a standstill. Always ensure that the parking brake is engaged to park the mower at a standstill.

Emergency Brake

In the event of service brake failure, turn the ignition off to bring the mower to a standstill.

⚠ WARNING

Take care when using the emergency braking. Remain seated and hold on to the steering wheel to prevent ejection from the mower caused by the front wheel brakes being applied suddenly when travelling.

Throttle Control

Operate the throttle control in a forward direction to increase the engine speed. Operate the throttle control in a rearward direction to reduce engine speed (Figure 7).

Note: The engine speed dictates the speed of the other functions, i.e. travel, reel rotation speed, and cutting unit lift speed.

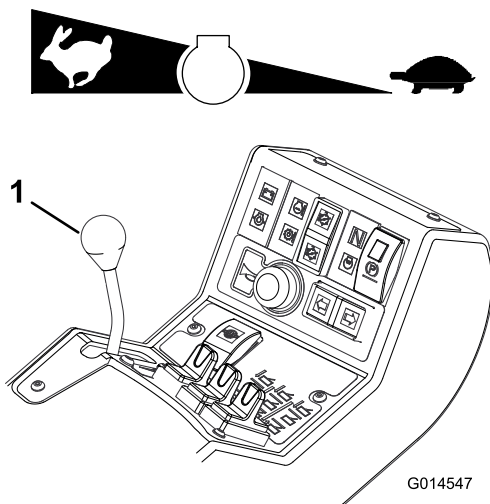

Figure 7

1. Throttle control lever

Travel

Forward travel: Press the forward travel pedal to increase forward travel speed. Release the pedal to reduce speed (Figure 8).

Reverse travel: Press the reverse travel pedal to increase reverse travel speed. Release the pedal to reduce speed (Figure 8).

Stop (Neutral): Release the forward or reverse travel pedal.

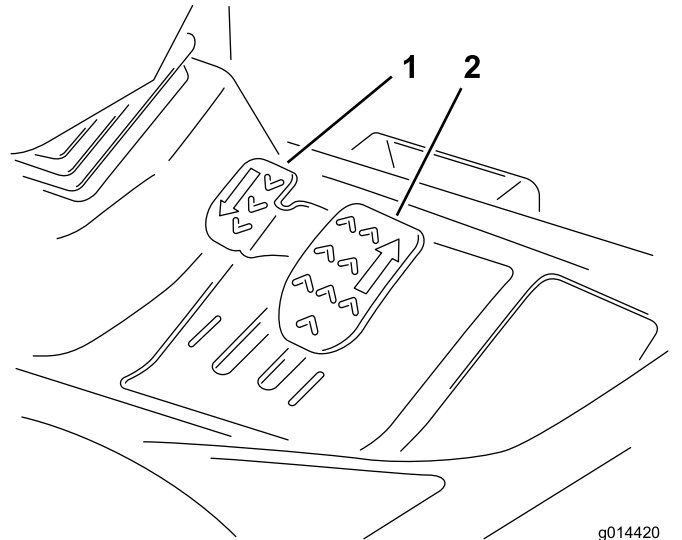

Figure 8

1. Reverse travel pedal
2. Forward travel pedal

Differential Lock

⚠ WARNING

The turning radius increases when the differential lock is engaged. Using the differential lock at high speed may lead to loss of control and cause serious injury and/or property damage.

Do not use the differential lock at high speed.

Use the differential lock to prevent excessive wheel spin when the drive wheels lose traction. The differential lock operates in both forward and reverse. You can lock the differential while the machine is traveling slowly. Engine power demand increases when the differential is locked. Prevent excessive power requirements by using the differential lock only at low speed.

To lock the differential, press the differential lock switch.

To unlock the differential, release the differential lock switch.

Transport Latches

Always raise the cutting units to the transport position and secure with the transport latches and safety locks when travelling between work areas (Figure 9).

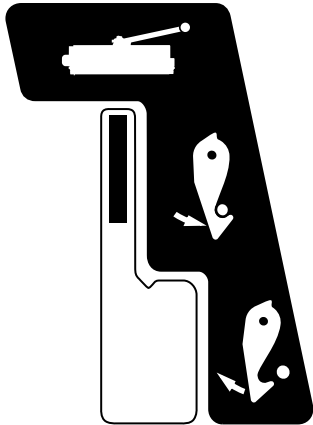

G014548

g014548

Figure 9

Cutting Unit Drive Switch

Always put the cutting unit drive switch in the **Off** position when travelling between work areas.

Adjustable Steering Column

⚠ WARNING

Never operate the machine without first checking that the steering column adjuster mechanism is in good working order and that, once adjusted and locked, the steering wheel remains securely in position.

Adjustment of the steering wheel and steering column should only be carried out when the mower is at a standstill with the parking brake engaged.

1. To tilt the steering wheel, press the foot pedal down.
2. Position the steering tower to the most comfortable position and release the pedal (Figure 10).



G014549

g014549

Figure 10

Operator Seat

⚠ WARNING

Never operate the mower without first checking that the operator seat mechanisms are in good working order and that, once adjusted and locked, the seat remains securely in position.

Adjustment of the seat mechanisms should only be carried out when the mower is at a standstill with the parking brake engaged.

- **Fore/Aft Adjustment:** Move the lever upward to adjust the fore/aft position of the seat. Release the lever to lock the seat in position (Figure 11).

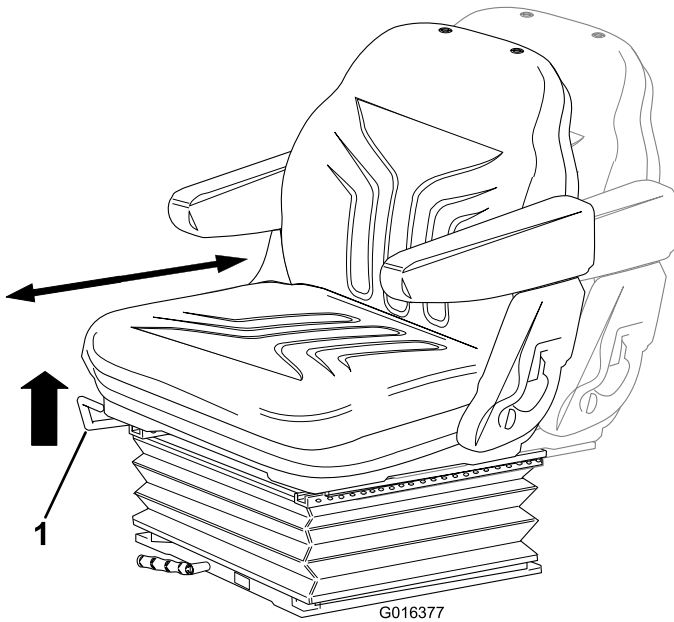

Figure 11

1. Lever

- **Operator weight adjustment:** Rotate the handle clockwise to increase suspension stiffness and counterclockwise to decrease the stiffness. The dial indicates when the optimum suspension adjustment has been set according to operator weight (kg); refer to Figure 12.

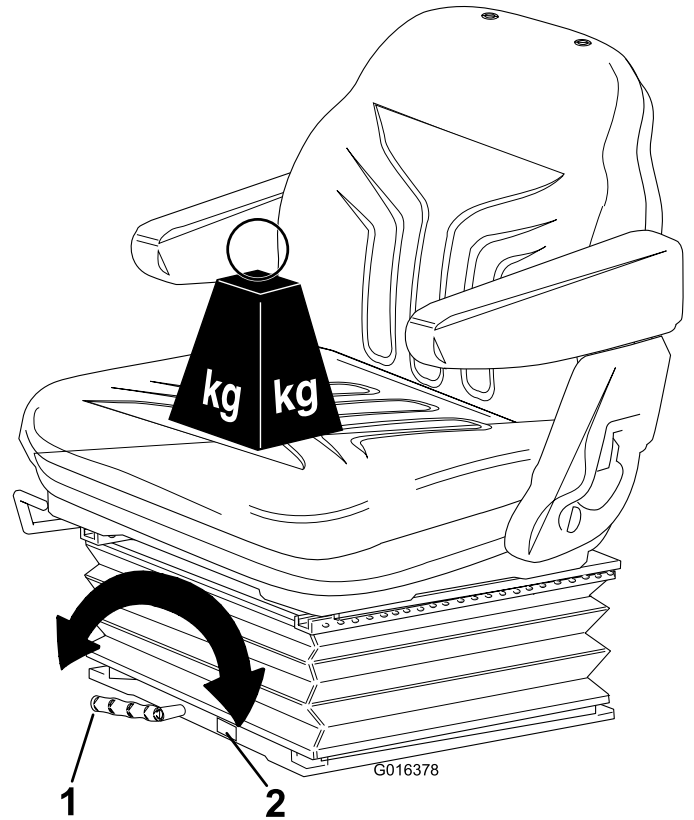

Figure 12

1. Lever
2. Dial

- **Height adjustment:** Manually lift the seat for incremental height adjustment. To lower the seat, lift it beyond the highest setting, then allow it to drop to the lowest setting (Figure 13).

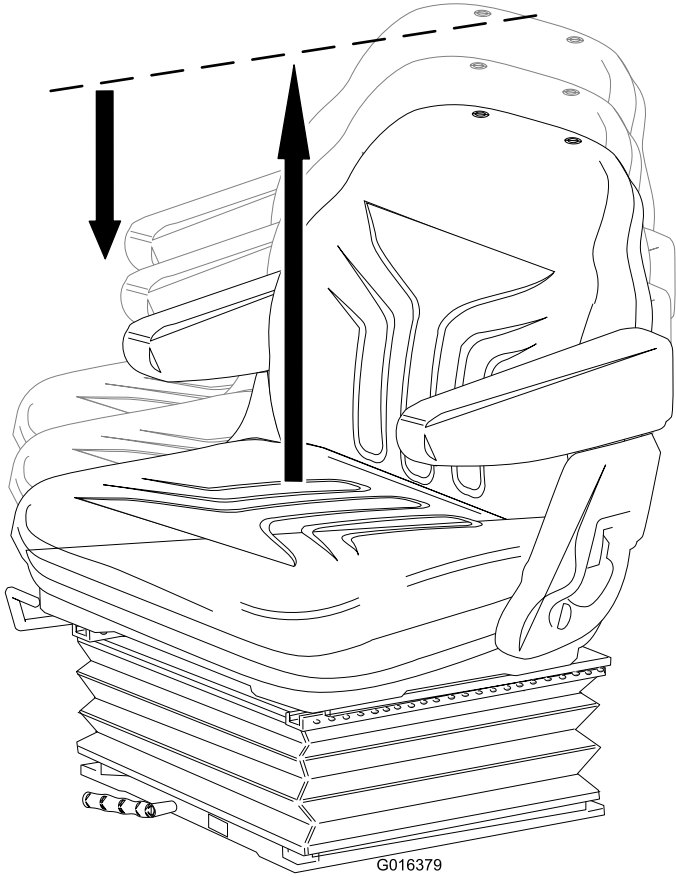

Figure 13

G016379

g016379

- **Backrest adjustment:** Pull the handle outward to adjust the seat backrest angle. Release the handle to lock the seat backrest in position (Figure 14).

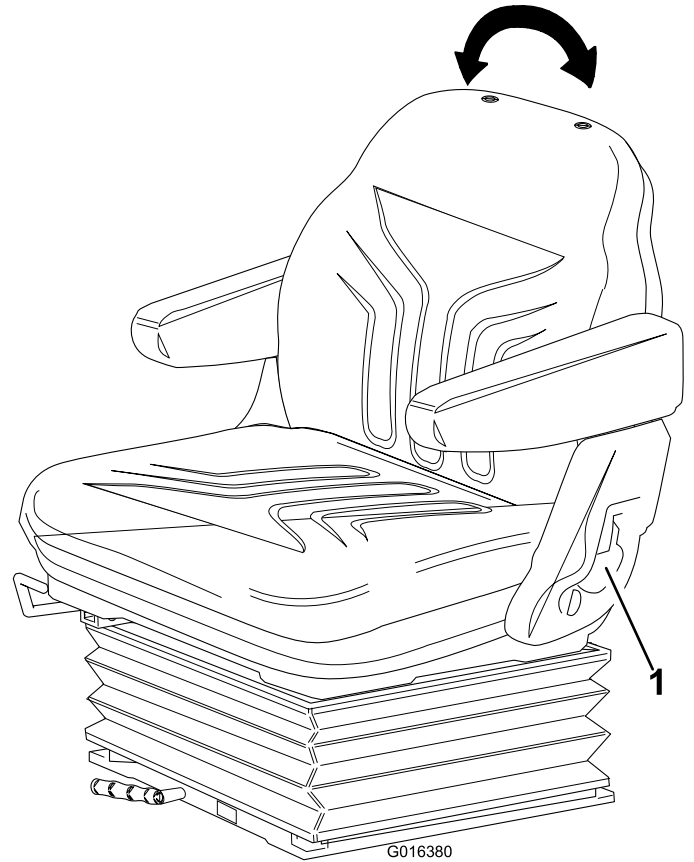

Figure 14

G016380

g016380

1. Handle

Warning Systems

Engine Coolant Overheating Warning Light

The engine coolant warning light illuminates, the horn is actuated and the cutting units stop (Figure 15).

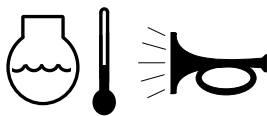
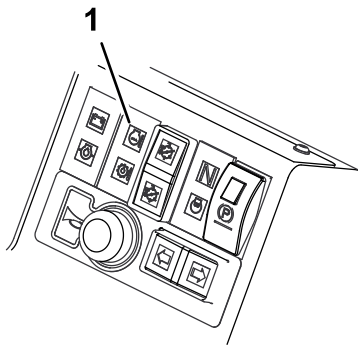

G014551

g014551

Figure 15

1. Engine coolant overheating warning light

Hydraulic Oil Overheating Warning Light

The hydraulic oil warning light illuminates when overheating occurs and the horn is actuated when the hydraulic oil in the reservoir exceeds 95 degrees C (203 degrees F) (Figure 16).

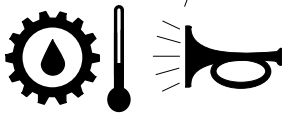
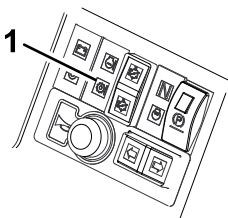

G014552

g014552

Figure 16

1. Hydraulic oil overheating warning light

Low Battery Charge Warning Light

The battery charge warning light illuminates when low battery charge occurs (Figure 17).

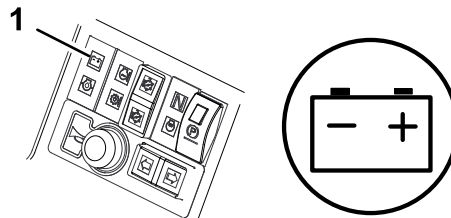

G014553

g014553

Figure 17

1. Low battery charge warning light

Low Engine Oil Pressure Warning Light

The engine oil pressure warning light illuminates when the oil pressure is too low (Figure 18).

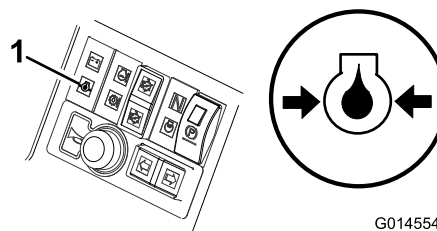

G014554

g014554

Figure 18

1. Low engine oil pressure warning light

Disengagement of Reels

The reels will disengage when the operating temperature reaches 115 degrees C.

Audible Warning Horn

Service Interval: Before each use or daily—Check the horn.

Press the horn button to provide an audible warning (Figure 19).

Important: The horn is automatically actuated when an engine coolant or hydraulic fluid overheat condition occurs. Shut off the engine immediately and fix the machine before starting it again.

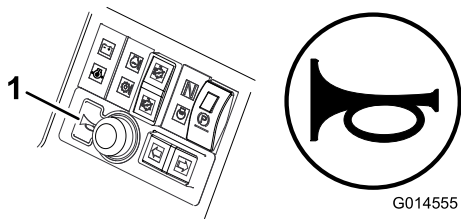

Figure 19

1. Horn

Key Switch

0 = Engine off
I = Engine run/Auxiliary on
II = Engine pre-heat
III = Engine start

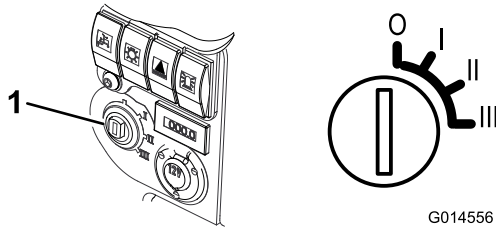

Figure 20

1. Key switch

Engine Pre-Heat Indicator Light

Turn the key to position II. The engine preheat indicator light will illuminate and heat the glow plugs (Figure 21).

Important: Attempting to start a cold engine before the pre-heat is used can cause unnecessary wear to the battery.

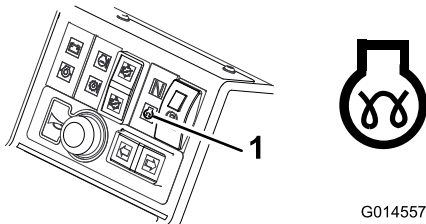

Figure 21

1. Engine pre-heat indicator light

Fuel Gauge

The fuel gauge shows the amount of fuel in the tank (Figure 22).

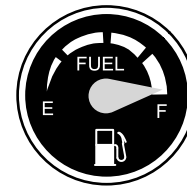

Figure 22

Hour Meter

The hour meter shows the total hours that the machine has been operated (Figure 23).



Figure 23

1. Hour meter

Transmission Neutral Indicator Light

This light illuminates when the travel control pedal is in the neutral position and the ignition key is turned to position I (Figure 24).

Note: The parking brake must be engaged for the transmission neutral indicator light to illuminate.

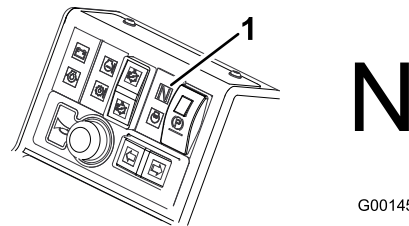
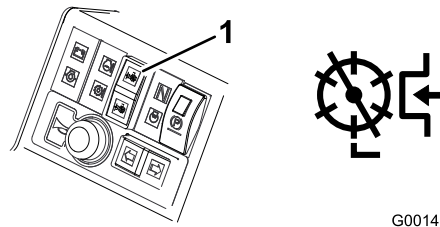

Figure 24

1. Transmission neutral indicator light

Cutting Unit Drive Switch Indicator Light

This light illuminates when the cutting unit drive switch is in the forward/reverse position and the ignition key is turned to position I (Figure 25).



G0014561

g014561

Figure 25

1. Cutting unit drive switch indicator light

Specifications

Note: Specifications and design are subject to change without notice.

Specification	LT 3340
Transport Width	157.5 cm (62 inches)
Width of cut	212.0 cm (83.5 inches)
Overall width	236.0 cm (92.9 inches)
Length	286.0 cm (112.6 inches)
Height	168.1 cm (66.2 inches) with ROPS folded 216.0 cm (85.0 inches) with ROPS in its vertical operating position
Weight	1325 kg (2921 lb)* With fluids and 250-mm, 6-blade cutting units
Engine	Kubota 26.5 kw (35.5 hp) at 3000 rpm DIN 70020
Fuel tank capacity	45 L (11.9 US gallons)
Transport speed	25 km/h (15.5 mph)
Mowing speed	11 km/h (6.85 mph)
Hydraulic system capacity	32 L (8.5 US gallons)
Engine speed	3000 rpm

Attachments/Accessories

A selection of Toro approved attachments and accessories is available for use with the machine to enhance and expand its capabilities. Contact your Authorized Service Dealer or authorized Toro distributor or go to www.Toro.com for a list of all approved attachments and accessories.

To ensure optimum performance and continued safety certification of the machine, use only genuine Toro replacement parts and accessories. Replacement parts and accessories made by other manufacturers could be dangerous, and such use could void the product warranty.

Operation

Before Operation

Before Operation Safety

General Safety

- Never allow children or untrained people to operate or service the machine. Local regulations may restrict the age of the operator. The owner is responsible for training all operators and mechanics.
- Become familiar with the safe operation of the equipment, operator controls, and safety signs.
- Shut off the engine, remove the key (if equipped), and wait for all movement to stop before you leave the operator's position. Allow the machine to cool before adjusting, servicing, cleaning, or storing it.
- Know how to stop the machine and shut off the engine quickly.
- Do not operate the machine without all guards and other safety protective devices in place and functioning properly on the machine.
- Before mowing, always inspect the machine to ensure that the cutting units are in good working condition.
- Inspect the area where you will use the machine and remove all objects that the machine could throw.

Fuel Safety

- Use extreme care in handling fuel. It is flammable and its vapors are explosive.
- Extinguish all cigarettes, cigars, pipes, and other sources of ignition.
- Use only an approved fuel container.
- Do not remove the fuel cap or fill the fuel tank while the engine is running or hot.
- Do not add or drain fuel in an enclosed space.
- Do not store the machine or fuel container where there is an open flame, spark, or pilot light, such as on a water heater or other appliance.
- If you spill fuel, do not attempt to start the engine; avoid creating any source of ignition until the fuel vapors have dissipated.

Performing Daily Maintenance

Service Interval: Before each use or daily

Before starting the machine each day, perform the Each Use/Daily procedures listed in [Maintenance \(page 29\)](#).

Filling the Fuel Tank

Fuel Tank Capacity

45 L (11.9 US gallons)

Fuel Specification

Failure to observe the following cautions may damage the engine.

- Never use kerosene or gasoline instead of diesel fuel.
- Never mix kerosene or used engine oil with the diesel fuel.
- Never keep fuel in containers with zinc plating on the inside.
- Do not use fuel additives.

Petroleum Diesel

Use only clean, fresh diesel fuel or biodiesel fuels with low (<500 ppm) or ultra-low (<15 ppm) sulfur content. The minimum cetane rating should be 40. Purchase fuel in quantities that can be used within 180 days to ensure fuel freshness.

Use summer-grade diesel fuel (Number 2-D) at temperatures above -7°C (20°F) and winter-grade diesel fuel (Number 1-D or Number 1-D/2-D blend) below -7°C (20°F). Using winter-grade fuel at lower temperatures provides a lower flash point and cold-flow characteristics, which will ease starting and reduce fuel-filter plugging.

Using summer-grade fuel above -7°C (20°F) will contribute toward longer fuel-pump life and increased power compared to winter-grade fuel.

Adding Fuel

1. Park the machine on a level surface, lower the cutting units, engage the parking brake, shut off the engine, and remove the key.
2. Using a clean rag, clean the area around the fuel-tank cap.
3. Remove the cap from the fuel tank.
4. Fill the tank until the level is to the bottom of the filler neck with diesel fuel.

5. Install fuel-tank cap tightly after filling tank.
Note: If possible, fill the fuel tank after each use. This minimizes possible buildup of condensation inside the fuel tank.

During Operation

During Operation Safety

General Safety

- The owner/operator can prevent and is responsible for accidents that may cause personal injury or property damage.
- Wear appropriate clothing, including eye protection; long trousers; substantial, slip-resistant footwear; and hearing protection. Tie back long hair and do not wear loose clothing or loose jewelry.
- Do not operate the machine while ill, tired, or under the influence of alcohol or drugs.
- Use your full attention while operating the machine. Do not engage in any activity that causes distractions; otherwise, injury or property damage may occur.
- Before you start the engine, ensure that all drives are in neutral, the parking brake is engaged, and you are in the operating position.
- Do not carry passengers on the machine and keep bystanders and children out of the operating area.
- Operate the machine only in good visibility to avoid holes or hidden hazards.
- Avoid mowing on wet grass. Reduced traction could cause the machine to slide.
- Keep your hands and feet away from the cutting units.
- Look behind and down before backing up to be sure of a clear path.
- Use care when approaching blind corners, shrubs, trees, or other objects that may obscure your vision.
- Stop the cutting units whenever you are not mowing.
- Slow down and use caution when making turns and crossing roads and sidewalks with the machine. Always yield the right-of-way.
- Operate the engine only in well-ventilated areas. Exhaust gases contain carbon monoxide, which is lethal if inhaled.
- Do not leave a running machine unattended.
- Before you leave the operator's position, do the following:

- Park the machine on a level surface.
- Disengage the cutting unit(s) and lower the attachments.
- Engage the parking brake.
- Shut off the engine and remove the key (if equipped).
- Wait for all movement to stop.
- Operate the machine only in good visibility and appropriate weather conditions. Do not operate the machine when there is the risk of lightning.

Rollover Protection System (ROPS) Safety

- **Do not** remove the ROPS from the machine.
- Ensure that the seat belt is attached and that you can release it quickly in an emergency.
- Check carefully for overhead obstructions and do not contact them.
- Keep the ROPS in safe operating condition by thoroughly inspecting it periodically for damage and keeping all the mounting fasteners tight.
- Replace a damaged ROPS. Do not repair or alter it.

Machines with a Foldable Roll Bar

- Always use the seat belt with the roll bar in the raised position.
- The ROPS is an integral safety device. Keep a folding roll bar in the raised and locked position, and use the seat belt when operating the machine with the roll bar in the raised position.
- Lower a folding roll bar temporarily only when necessary. Do not wear the seat belt when the roll bar is folded down.
- Be aware that there is no rollover protection when a folded roll bar is in the down position.
- Check the area that you will be mowing and never fold down a folding roll bar in areas where there are slopes, drop-offs, or water.

Slope Safety

- Slopes are a major factor related to loss of control and rollover accidents, which can result in severe injury or death. The operator is responsible for safe slope operation. Operating the machine on any slope requires extra caution.
- Evaluate the site conditions to determine if the slope is safe for machine operation, including surveying the site. Always use common sense and good judgment when performing this survey.

- Review the slope instructions listed below for operating the machine on slopes and review the conditions in which you will operate the machine to determine whether you can operate it in the conditions on that day and at that site. Changes in the terrain can result in a change in slope operation for the machine.
- Avoid starting, stopping, or turning the machine on slopes. Avoid making sudden changes in speed or direction. Make turns slowly and gradually.
- Do not operate a machine under any conditions where traction, steering, or stability is in question.
- Remove or mark obstructions such as ditches, holes, ruts, bumps, rocks, or other hidden hazards. Tall grass can hide obstructions. Uneven terrain could overturn the machine.
- Be aware that operating the machine on wet grass, across slopes, or downhill may cause the machine to lose traction. Loss of traction to the drive wheels may result in sliding and a loss of braking and steering.
- Use extreme caution when operating the machine near drop offs, ditches, embankments, water hazards or other hazards. The machine could suddenly roll over if a wheel goes over the edge or the edge caves in. Establish a safety area between the machine and any hazard.
- Identify hazards at the base of the slope. If there are hazards, mow the slope with a pedestrian-controlled machine.
- If possible, keep the cutting unit(s) lowered to the ground while operating on slopes. Raising the cutting unit(s) while operating on slopes can cause the machine to become unstable.
- Use extreme caution with grass collection systems or other attachments. These can change the stability of the machine and cause a loss of control.

Releasing the Platform

1. Move the locking latch handle towards the front of the mower until the latch hooks clear the locking bar.
2. Raise the platform. The gas spring will provide assistance.

Using the Operator Platform Latching Mechanism

Do not operate the mower without first checking that the operator platform latching mechanism is fully engaged and in good working order.

⚠ WARNING

Never operate the mower without first checking that the operator platform latching mechanism is fully engaged and in good working order.

Securing the Platform

1. Lower the platform carefully.

Note: The gas spring will provide assistance.

2. Move the locking latch handle towards the front of the mower as the platform nears the fully lowered position.

Note: This will ensure that the latch hooks clear the locking bar.

3. Fully lower the platform and move the locking handle towards the rear of the mower until the latch hooks fully engage the locking bar.

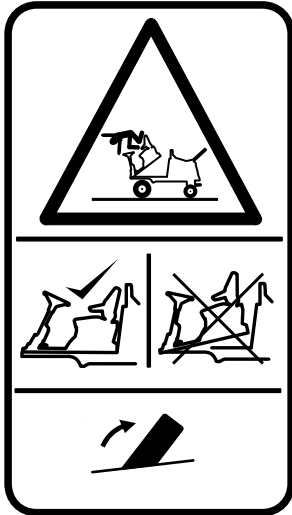

G014422

g014422

Figure 26

Understanding the Operator Presence Controls

Note: The engine stops if the operator leaves the seat without engaging the parking brake.

Engine Start Lockout: The engine can only be started when the forward/reverse travel pedal is in the **Neutral** position, the cutting unit drive switch is in the **Off** position and the parking brake is engaged. When these circumstances are satisfied, switches are activated permitting the engine to be started.

Engine Run Interlock: Once the engine is started the operator must be seated before the parking brake is disengaged for the engine to continue to run.

Cutting Unit Drive Lockout: The drive to the cutting units is only possible when the operator is seated. If the operator raises off the seat for a period of more than one second, a switch is activated and the drive

to the cutting units is automatically disengaged. To engage the drive to the cutting units, the operator must return to the seat, then operate the cutting unit drive switch to the **Off** position before moving it back to the **On** position. If the operator rises off the seat for a brief moment during normal work, drive to the cutting units is not affected.

The engine can only be started with the cutting unit drive switch in the **Off** position.

⚠ WARNING

Do not operate the turf mower if the operator presence controls are malfunctioning in any way. Always replace damaged or worn parts and check that they function correctly before operating the machine.

⚠ CAUTION

If safety interlock switches are disconnected or damaged the machine could operate unexpectedly causing personal injury.

- Do not tamper with the interlock switches.
- Check the operation of the interlock switches daily and replace any damaged switches before operating the machine.

Folding the Roll Bar

You can fold the roll bar down to allow access into areas of restricted height.

⚠ WARNING

The machine does not have a rollover protection system (ROPS) when the roll bar is folded down and should not be considered a ROPS.

Do not wear a seatbelt when the roll bar is lowered.

1. Park the machine on a level surface, lower the cutting units, engage the parking brake, shut off the engine, and remove the key.
2. Support the weight of the upper frame of the roll bar while removing the snap pins and clevis pins from the pivot brackets (Figure 27).

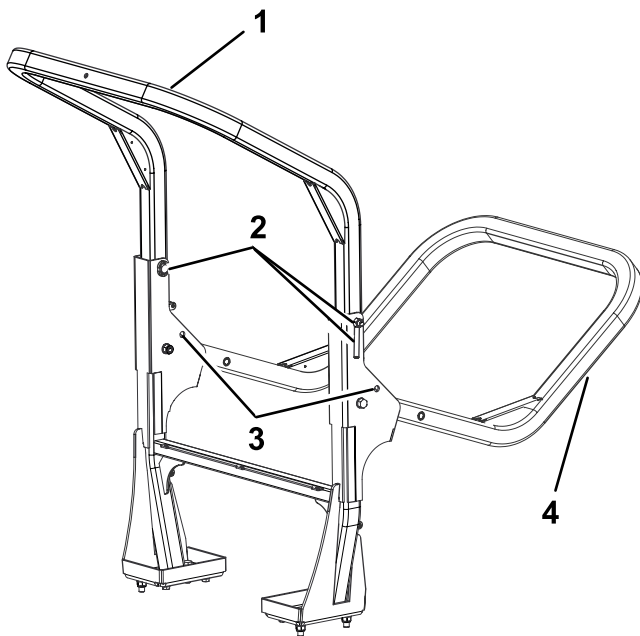

Figure 27

- | | |
|-----------------------------------|------------------------------------|
| 1. Upper frame in raised position | 3. Lower holes |
| 2. Clevis pins and snap pins | 4. Upper frame in lowered position |

3. Carefully lower the frame downward until it rests on the stops.
4. Insert the clevis pins in the lower holes and secure them with the snap pins to support the upper frame in its lowered position.
5. To raise the frame, follow these instructions in reverse order.

⚠ WARNING

The ROPS protection system may not be effective if the ROPS retaining bolt assemblies are loose, which may cause serious injury or even death in the event of a rollover.

When in the raised position, both retaining bolt assemblies must be installed and fully tightened to ensure full ROPS protection.

⚠ WARNING

When lowering and raising the roll bar, fingers may get pinched between the machine and the roll bar.

Use caution when lowering and raising the roll bar to prevent entrapment of fingers between the fixed part and the pivot part of the structure.

- Keep all nuts, bolts, and screws correctly torqued ensure that the equipment is in safe working condition.
- Replace worn or damaged parts for safety.
- Ensure that the seat belt and mountings are in safe working order.
- Wear the seat belt when the roll bar is raised and no seat belt when the roll bar is lowered.

Important: The roll bar is an integral safety device. Keep the roll bar in the raised position when operating the mower. Lower the roll bar temporarily only when absolutely necessary.

Checking the Interlock Switches

Checking the Forward/Reverse Travel Pedal Action

With the engine shut off, operate the forward and reverse travel pedals through the full range of articulation and ensure that the mechanism returns freely to the neutral position.

Checking the Operator Presence Seat Switch

Service Interval: Before each use or daily

1. Sit on the operator seat and start the engine.
2. Lower the cutting units to the ground.
3. Engage that the cutting unit drive in the forward direction.
4. Rise from the operator seat and check that the cutting units come to a stop after an initial 0.5 to 1 second delay.
5. Repeat the procedure with the reels running in reverse.

Checking the Cutting Unit Drive Interlock Switch

1. Shut off the engine.
2. Operate the cutting unit drive switch to the off position and turn the ignition key to position I. The cutting unit drive switch indicator light should not illuminate.
3. Operate the switch to the forward position. The indicator light should illuminate and the engine

should not start when the ignition key is turned. Repeat for the reverse position.

Checking the Parking Brake Interlock Switch

1. Shut off the engine.
2. Engage the parking brake.
3. Turn the ignition key to position I. The parking brake indicator light should illuminate.
4. Disengage the parking brake. The indicator light should go out and the engine should not start when the ignition key is turned.
5. Engage the parking brake, sit on the operator seat, and start the engine.
6. Disengage the parking brake.
7. Rise from the operator seat and check that the engine shuts off.

Checking the Transmission Neutral Interlock Switch

1. Shut off the engine.
2. Remove your foot from the forward/reverse travel pedals.
3. Turn the ignition key to position I and the transmission neutral indicator light should illuminate.
4. Apply light pressure to the travel pedals in a forward and reverse direction to check that the indicator light turns off.

Note: Take extreme care to ensure that the area around the machine is clear before checking that the engine will not start under this condition.

Starting the Engine

Important: You must bleed the fuel system before starting the engine if you are starting the engine for the first time, the engine has stopped due to lack of fuel, or you have performed maintenance on the fuel system; refer to [Bleeding the Fuel System \(page 36\)](#).

Important: This machine is fitted with an engine start lockout; refer to [Understanding the Operator Presence Controls \(page 20\)](#).

1. Sit on the seat, keep your foot off the traction pedals so that it is in NEUTRAL, ensure that the cutting unit drive switch is off, engage the parking brake, and set the throttle to the 70 percent full-throttle position.

2. Turn the key to the on position I and check that the engine oil pressure and battery charge warning lights illuminate.
3. If the engine is cold, turn the key to the preheat position II so that the pre-heat indicator light is on ([Figure 21](#)). Hold it for 5 seconds to heat the glow plugs.
4. After preheating the glow plugs or if the engine is already warm, turn the key to the start position III and hold it there to crank the engine.
Crank the engine for no longer than 15 seconds. Release the key back to position I when the engine starts.
5. Run the engine at low idle speed until it warms up.

Important: When the engine is operating all warning lights should be off. If a warning light illuminates, shut off the engine immediately and fix the issue before starting the engine.

Shutting Off the Engine

⚠ WARNING

Keep hands clear of moving objects and hot engine parts while the engine is running.

1. Move all controls to NEUTRAL, engage the parking brake, move the throttle to the low idle position and allow the engine to reach low idle speed.
Important: Allow the engine to idle for 5 minutes before shutting it off after a full load operation. Failure to do so may lead to trouble on a turbo-charged engine.
2. Let the engine idle for 5 minutes.
3. Turn the key to position 0.

If the engine fails to shut off when the key is turned to 0, operate the engine shutoff lever in the forward direction ([Figure 28](#)).

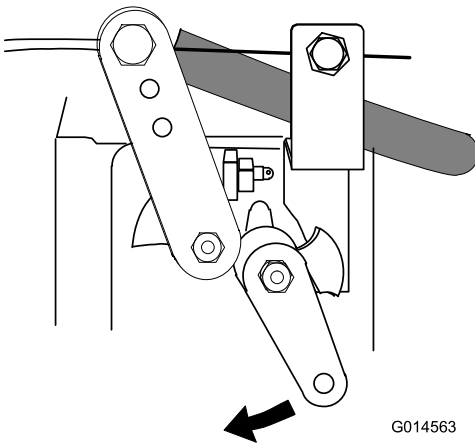

Figure 28

Controlling the Position of the Individual Cutting units

The cutting units may be raised or lowered independently using the bank of 3 lift control switches.

1. To lower the cutting units, operate the lift control switches in a downward direction and release.

The cutting unit drive switch must be on (forward) to do this, the reel drive will engage when the cutting units are approximately 150 mm (6 inches) above ground level. The cutting units are now in 'float' mode and will follow the ground contours.

2. To raise the cutting units, operate the lift control switches in an upward direction and hold in position 3. If the cutting unit drive switch is in the **On** position the reel drive will disengage immediately.

3. Release the lift control switches when the cutting units are at the required height.

The control switches will automatically return to position 2 (neutral) and the arms are hydraulically locked into position.

Using the Grass Deflectors

The rear grass deflectors must always be correctly fitted. The deflectors should be set as low as possible to deflect grass discharge to the ground (Figure 29).

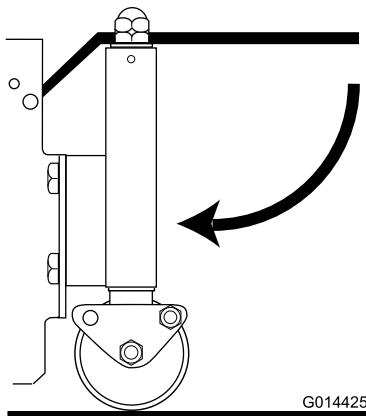

Figure 29

Adjusting the Cutting Unit Auto Limited Lift

To activate, press the Auto Limited Lift switch to the **On** position (Figure 30).

To deactivate, press the Auto Limited Lift switch to the **Off** position (Figure 30).

Manual limited lift using the 3 lift control switches is always available regardless of the position of the Auto switch.

Adjusting the Center Cutting Unit Height-of-Cut Correction

With all cutting units set at the same HOC via the indicator rings, it may be noticeable that the center unit produces a higher cut finish compared to the wing units. The center unit is pulled and the wing units are pushed; this presents marginally different cutting angles relative to the ground. The amount of HOC variation which results from this will be influenced by the terrain, but satisfactory results can usually be achieved by setting the center cutting unit HOC indicator ring lower than the wing unit settings.

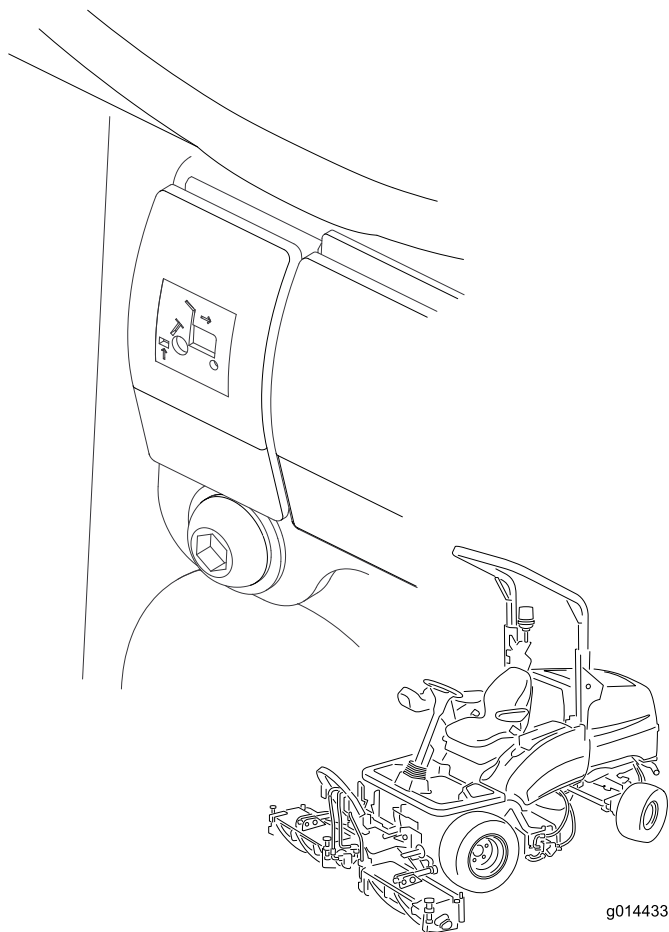

Figure 30

To raise the cutting units to the limited lift position: momentarily operate the switches in an upward direction.

The reel drive will disengage immediately and the cutting units will stop raising, approximately 150 mm (6 inches) above ground level.

This operates with the cutting units lowered and rotating.

Auto limited lift in reverse causes the cutting units to rise automatically to the limited lift position when reversing. They will return to the floating position when returning to forward travel. The cutting units continue to rotate during this operation.

Engaging the Cutting Unit Drive

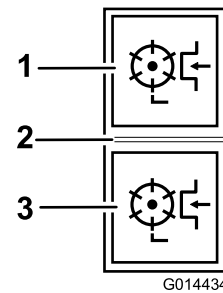

Figure 31

1. Forward
2. Off
3. Reverse

The cutting unit drive can be engaged only when the operator is seated correctly, refer to [Checking the Operator Presence Seat Switch \(page 21\)](#).

Forward rotation cutting unit drive engagement: Press the top of the cutting unit drive switch to the forward position (Figure 31).

Reverse rotation cutting unit drive engagement: Press the bottom of the cutting unit drive switch to the reverse position (Figure 31).

All cutting unit drives disengagement: Set the switch to the middle position (Figure 31).

To lower the cutting units: The cutting unit drive switch must be set to forward. Operate the lift control switch(s) in a downward direction. The reel will drive when the cutting units are approximately 150 mm (6 inches) above ground level.

Clearing the Cutting Units

⚠ WARNING

Never attempt to rotate the cutting units by hand.

- **There may be some residual pressure in the hydraulic system which could cause injury through sudden movement of the cutting unit(s) when the blockage is released.**
- **Always wear protective gloves and use a suitable strong wooden instrument.**
- **Ensure that the wooden instrument will fit between the blades and through the reel and is long enough to provide sufficient leverage to release the blockage.**

1. Park the machine on a level surface.

2. Engage the parking brake and disengage all drives.
3. Lower the cutting units to the ground or securely lock them in the designated transport positions.
4. Shut off the engine and remove the ignition key to isolate all power sources and ensure that they are stopped.
5. Release all stored energy devices.
6. Check that all moving parts are stationary.
7. Using a suitable strong wooden instrument, remove the blockage. Ensure that the wooden instrument is properly supported in the cutting unit and avoid the use of excessive force to prevent damage.
8. Ensure that the wooden instrument is removed from the cutting unit before restarting the power source.
9. Repair or adjust the cutting unit if required.

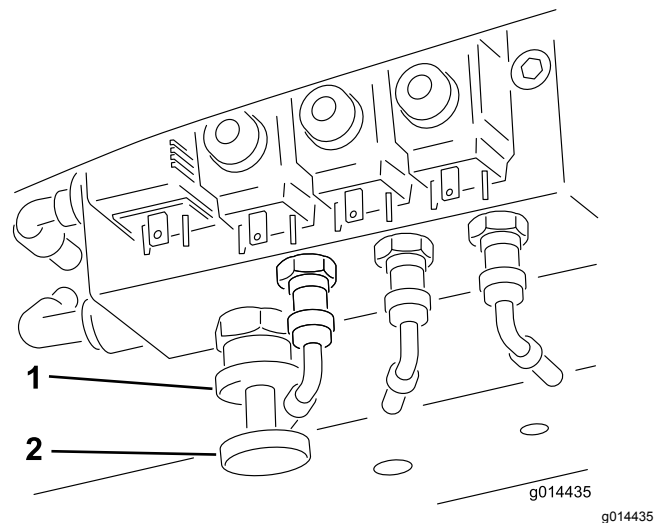

Figure 32

1. Lock wheel
2. Weight transfer hand wheel

Using Weight Transfer / Traction Assistance

A variable hydraulic weight transfer system is provided for improving tire grip with the grass surface—traction assistance.

Hydraulic pressure in the cutting unit lift system provides a lifting force which reduces the weight of the cutting units on the ground and transfers the weight as a downward force onto the tires of the machine. This action is known as weight transfer.

To engage weight transfer: The amount of weight transfer can be varied to suit operating conditions by rotating the weight transfer hand wheel (Figure 32) as follows:

1. Release the valve locknut 1/2 turn counterclockwise and hold (Figure 32).
2. Rotate the valve hand wheel (Figure 32) counterclockwise to reduce weight transfer or clockwise to increase weight transfer.
3. Tighten the nut.

Operating Tips

Becoming Familiar with the Machine

Before mowing grass, practice operating the machine in an open area. Start and shut off the engine. Operate in forward and reverse. Lower and raise the cutting units and engage and disengage the cutting units. When you feel familiar with the machine, practice operating up and down slopes at different speeds.

Understanding the Warning System

If a warning light comes on during operation, stop the machine immediately and correct the problem before continuing operation. Serious damage could occur if you operate the machine with a malfunction.

Mowing Grass

The rotational speed of the cutting units should always be kept as high as possible in order to maintain the highest quality of cut. This in turn requires that the engine speed be kept as high as possible.

Cutting performance is best when cutting against the lie of the grass. In order to take advantage of this fact, the operator should attempt to alternate the direction of mowing between cuts.

Take care not to leave uncut strips of grass at the overlap points between adjacent cutting units by avoiding tight turns.

Maximizing the Quality of Cut

The quality of cut will deteriorate if the forward speed is excessive. Always balance the quality of cut with the work rate required and set the forward speed accordingly.

Maximizing Engine Efficiency

Do not let the engine labor. If you notice that the engine starts to labor, reduce the forward speed or increase the height of cut. Check that the reels are not in heavy contact with their bedknives.

Driving the Machine in Transport Mode

Always disengage the cutting unit drive when travelling across areas with no grass. Grass lubricates the cutting edges while mowing. Excessive heat builds up if the cutting units are run when not mowing, resulting in rapid wear. For this reason it is also wise to reduce cutting speed when mowing lightly grassed areas or when the grass is dry. Be careful when driving between objects so that you do not accidentally damage the machine or the cutting units.

⚠ WARNING

Take care when travelling over obstacles such as roadside curbs. Always travel at slow speed over obstacles to prevent damage to the tires, wheels, and the steering system. Ensure that the tires are inflated to the recommended pressures.

Operating the Machine on Slopes

Use extra care when operating the machine on slopes. Drive slowly and avoid sharp turns on slopes to prevent roll-overs. Lower the cutting units for steering control when going downhill.

Using the Rear Roller Scrapers

It is generally wise to remove the rear roller scrapers where conditions allow, as optimum grass discharge is achieved without them. Install the scrapers when conditions are such that mud and grass start to build up on the rollers. When installing the scraper wires, ensure that they are correctly tensioned.

After Operation

After Operation Safety

General Safety

- Shut off the engine, remove the key (if equipped), and wait for all movement to stop before you leave the operator's position. Allow the machine to cool before adjusting, servicing, cleaning, or storing it.
- Clean grass and debris from the cutting units, drives, mufflers, cooling screens, and engine compartment to help prevent fires. Clean up oil or fuel spills.
- Shut off the fuel while storing or transporting the machine.
- Disengage the drive to the attachment whenever you are transporting or not using the machine.
- Maintain and clean the seat belt(s) as necessary.
- Do not store the machine or fuel container where there is an open flame, spark, or pilot light, such as on a water heater or on other appliances.

Identifying the Tie-Down Points

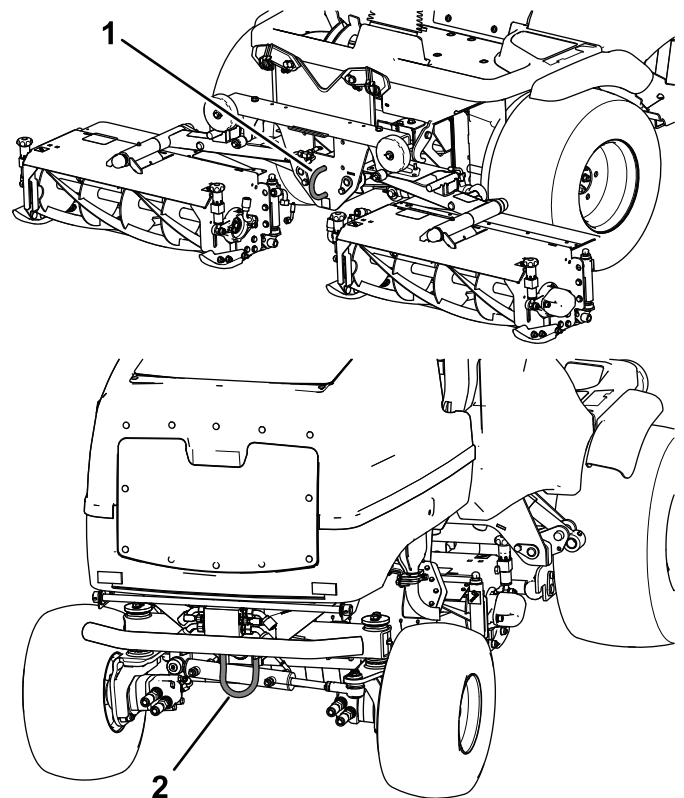

Figure 33

g281268

1. Front tie-down point

2. Rear tie-down point

Hauling the Machine

- Use full-width ramps for loading the machine onto a trailer or truck.
- Tie the machine down securely.

Locating the Jacking Points

Note: Use jack stands to support the machine when required.

⚠ WARNING

Mechanical or hydraulic jacks may fail to support the machine and cause serious injury.

Use jack stands when supporting the machine.

- Front—under the front arm mount
- Rear—axle tube on the rear axle

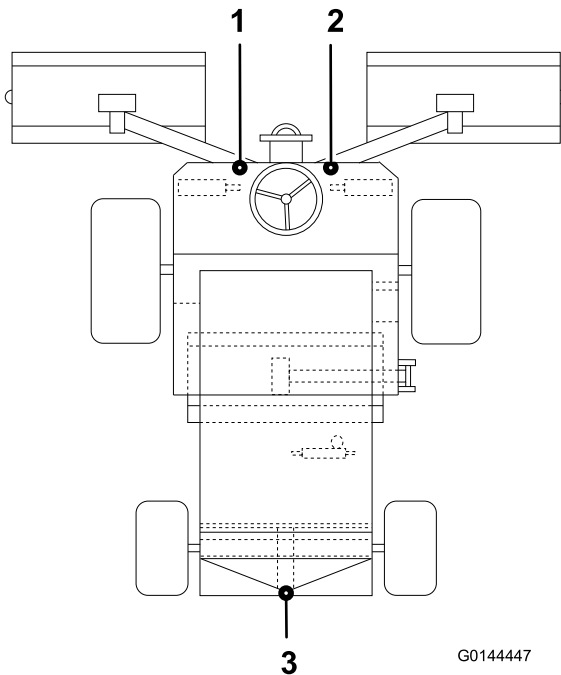

Figure 34

- 1. Front left lifting point
- 2. Front right lifting point
- 3. Rear lifting point

Towing the Machine

Ensure that the towing vehicle specification is suited to braking the combined vehicle weight and able to remain in complete control at all times. Ensure that the parking brake of the towing vehicle is engaged. Chock the front wheels of the machine to prevent the machine from rolling away.

Important: Do not tow the machine faster than 3 to 5 km/h (2 to 3 mph), otherwise internal transmission damage may occur.

Decommission the front wheel motor disc brakes as follows:

1. Connect a **rigid** tow bar between the towing eye on the front of the mower and a suitable towing vehicle.
2. Identify the right front wheel motor disc brake assembly and remove the hex plug (**Figure 35**).

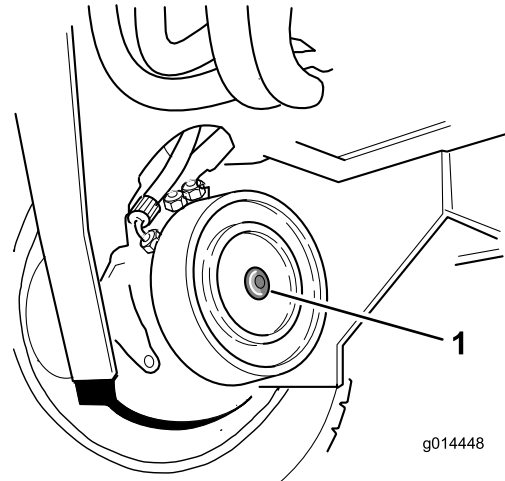

Figure 35

1. Hex plug

3. Locate the M12 x 40 mm setscrew and washer stored underneath the operator platform, one in each of the platform support rails.
4. Install a M12 x 40 mm long setscrew with washer into the hole in the center of the motor end plate (**Figure 36**).

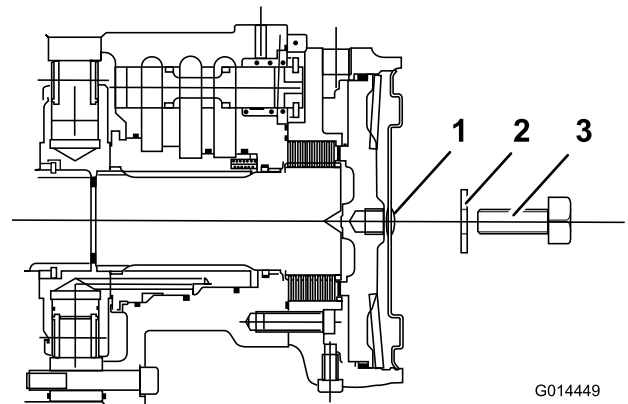

Figure 36

1. Hex plug
2. Washer M12
3. Setscrew M12 x 40

5. Tighten the setscrew into the threaded hole in the brake piston until the brake is released (Figure 36).
6. Identify the left front wheel motor disc brake assembly and repeat the previous procedure (Figure 36).
7. Decommission the hydraulic service braking system by turning the bypass valve, located under the transmission pump, counterclockwise, a maximum of 3 turns (Figure 37).

The steering must be operated manually when the mower is being towed. The steering will feel heavy as there is no hydraulic assistance when the engine is shut off.

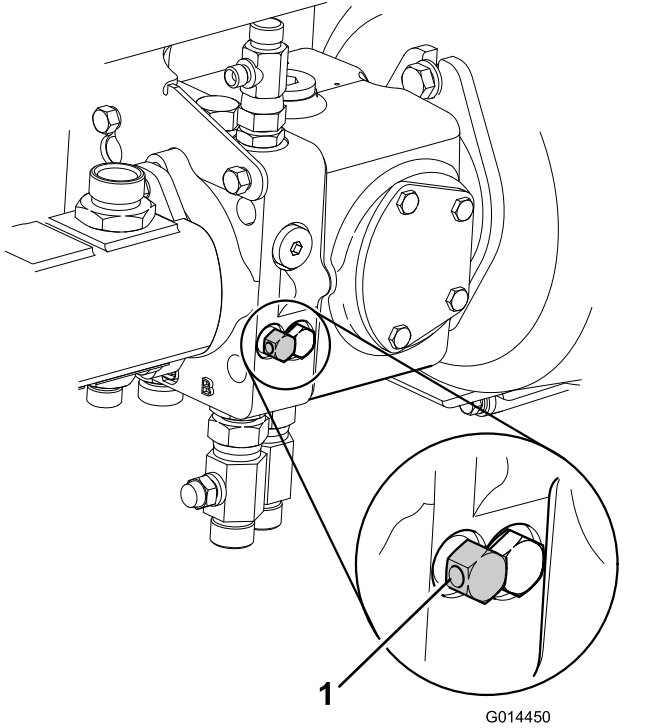

Figure 37

1. Transmission bypass valves

8. The mower is now in a freewheel condition and can be towed for a short distance at slow speed.

Note: Remove the wheel chocks before towing.

9. **After towing the mower:** To return the mower to its normal working condition the following procedure must be done:
 - A. Chock the front wheels.
 - B. Close the bypass valve on the transmission pump by turning it clockwise.

10. **Commission the front wheel motor disc brakes as follows:**

Note: Ensure that the M12 x 40 mm setscrews and washers are removed and stored underneath the operator platform.

- A. Identify the right front wheel motor disc brake assembly.
- B. Rotate the setscrew counterclockwise and remove together with the washer.
- C. Assemble the hex plug into the motor end plate (Figure 38).

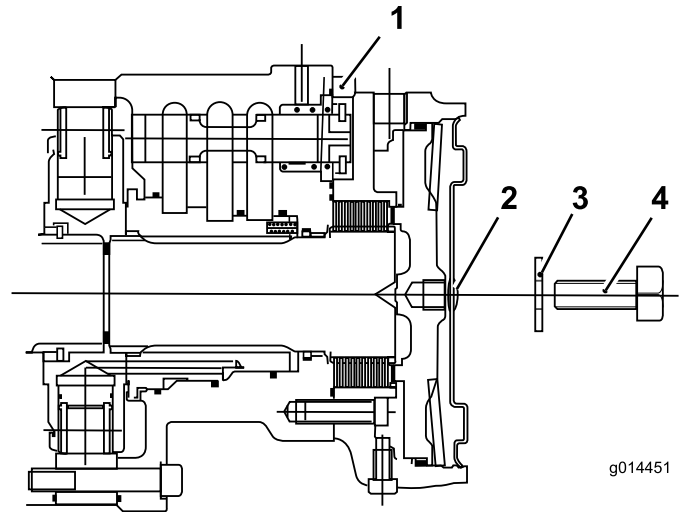

Figure 38

- | | |
|---------------------|-------------------------|
| 1. Front wheel moto | 3. Washer M12 |
| 2. Hex plug | 4. Setscrew M12 x 40 mm |

- D. Identify the left front wheel motor disc brake assembly and repeat the previous procedure.
- E. Remove the wheel chocks.
- F. Disconnect the tow bar.

Note: The mower braking system will now operate in the normal way.

⚠ WARNING

Before using the mower, ensure that the braking system operates correctly. Carry out initial checks with the mower at slow speed. Do not operate the mower with a damaged braking system. Do not operate the mower with the brakes decommissioned.

Maintenance

Note: Determine the left and right sides of the machine from the normal operating position.

Maintenance Safety

- Before adjusting, cleaning, servicing, or leaving the machine, do the following:
 - Park the machine on a level surface.
 - Move the throttle switch to the low-idle position.
 - Disengage the cutting units.
 - Lower the cutting units.
 - Ensure that the traction is in neutral.
 - Engage the parking brake.
 - Shut off the engine and remove the key.
 - Wait for all moving parts to stop.
 - Allow machine components to cool before performing maintenance.
- If possible, do not perform maintenance while the engine is running. Keep away from moving parts.
- Use jack stands to support the machine or components when required.
- Carefully release pressure from components with stored energy.
- Keep all parts of the machine in good working condition and all hardware tightened.
- Replace all worn or damaged decals.
- To ensure safe, optimal performance of the machine, use only genuine Toro replacement parts. Replacement parts made by other manufacturers could be dangerous, and such use could void the product warranty.

Recommended Maintenance Schedule(s)

Maintenance Service Interval	Maintenance Procedure
After the first 8 hours	<ul style="list-style-type: none"> • Check the condition and tension of the alternator belt.
After the first 50 hours	<ul style="list-style-type: none"> • Change the engine oil and filter. • Change the transmission oil filter. • Change the hydraulic return filter. • Check the engine speed (idle and full throttle).
Before each use or daily	<ul style="list-style-type: none"> • Check the horn. • Inspect the seat belt(s) for wear, cuts, and other damage. Replace the seat belt(s) if any component does not operate properly. • Check the safety interlock system. • Check the tire pressure. • Grease the bearings, bushings and pivots (grease them immediately after every washing regardless of the interval listed). • Check the air cleaner blockage indicator (service the air cleaner earlier if the air cleaner indicator shows red; service it more frequently in extremely dirty or dusty conditions). • Check the engine-oil level. • Torque the wheel lug nuts. • Remove debris from the screen, oil coolers, and radiator (more frequently in dirty operating conditions). • Check the hydraulic lines and hoses. • Check the hydraulic fluid level. • Check the hydraulic lines and hoses for leaks, kinked lines, loose mounting supports, wear, loose fittings, weather deterioration, and chemical deterioration. • Check the fasteners of the machine. • Check the cutting units. • Check the forward/reverse travel pedal action.
Every 50 hours	<ul style="list-style-type: none"> • Grease the bearings, bushings and pivots (grease them immediately after every washing regardless of the interval listed).
Every 100 hours	<ul style="list-style-type: none"> • Inspect the cooling system hoses. • Check the condition and tension of the alternator belt.

Maintenance Service Interval	Maintenance Procedure
Every 150 hours	<ul style="list-style-type: none"> • Change the engine oil and filter.
Every 250 hours	<ul style="list-style-type: none"> • Check the condition of the battery. • Check the condition of and clean the battery. • Check the battery cable connections. • Check the transmission control cable.
Every 400 hours	<ul style="list-style-type: none"> • Check the fuel lines and connections. • Check the engine speed (idle and full throttle).
Every 500 hours	<ul style="list-style-type: none"> • Check the engine overheat warning system. • Replace the primary air filter (more frequently in extreme dusty or dirty conditions). • Replace the fuel filter. • Check the electrical system. • Change the transmission oil filter. • Check the rear wheel alignment. • Change the hydraulic return filter. • Service the hydraulic system. • Check the hydraulic fluid overheat warning system.
Every 800 hours	<ul style="list-style-type: none"> • Drain and clean the fuel tank • Adjust the engine valves (refer to the engine operator's manual).
Before storage	<ul style="list-style-type: none"> • Drain and clean the fuel tank
Every 2 years	<ul style="list-style-type: none"> • Flush and replace the cooling system fluid. • Replace all moving hoses. • Replace the transmission cable.

Daily Maintenance Checklist

Duplicate this page for routine use.

Maintenance Check Item	For the week of:						
	Mon.	Tues.	Wed.	Thurs.	Fri.	Sat.	Sun.
Check the safety interlock operation.							
Check the brake operation.							
Check the engine oil and fuel level.							
Check the air filter restriction indicator.							
Check the radiator and screen for debris.							
Check unusual engine noises. ¹							
Check unusual operating noises.							
Check the hydraulic fluid level.							
Check hydraulic hoses for damage.							
Check for fluid leaks.							
Check the tire pressure.							
Check the instrument operation.							
Check the reel-to-bedknife adjustment.							
Check the height-of-cut adjustment.							
Check all grease fittings for lubrication. ²							
Touch-up damaged paint.							
Wash the machine.							

1. Check the glow plug and injector nozzles if the engine starts hard, produces excess smoke, or runs rough.
 2. Immediately after every washing, regardless of the interval listed

Notation for Areas of Concern

Inspection performed by:		
Item	Date	Information
1		
2		
3		
4		
5		
6		
7		
8		

Important: Refer to your engine operator's manual for additional maintenance procedures.

Note: Download a free copy of the electrical or hydraulic schematic by visiting www.Toro.com and searching for your machine from the Manuals link on the home page.

Lubrication

Greasing the Bearings, Bushings, and Pivots

Service Interval: Before each use or daily

Every 50 hours

Lubricate all grease fittings for the bearings and bushings with No. 2 lithium grease. Lubricate the bearings and bushings **immediately** after every washing, regardless of the interval listed.

Replace any damaged grease fittings.

Grease all cutting unit grease points and ensure that sufficient grease is injected such that clean grease is seen to escape from the roller end caps. This provides visible evidence that the roller seals have been purged of grass and debris and ensures maximum working life.

The grease fitting locations and quantities are as follows:

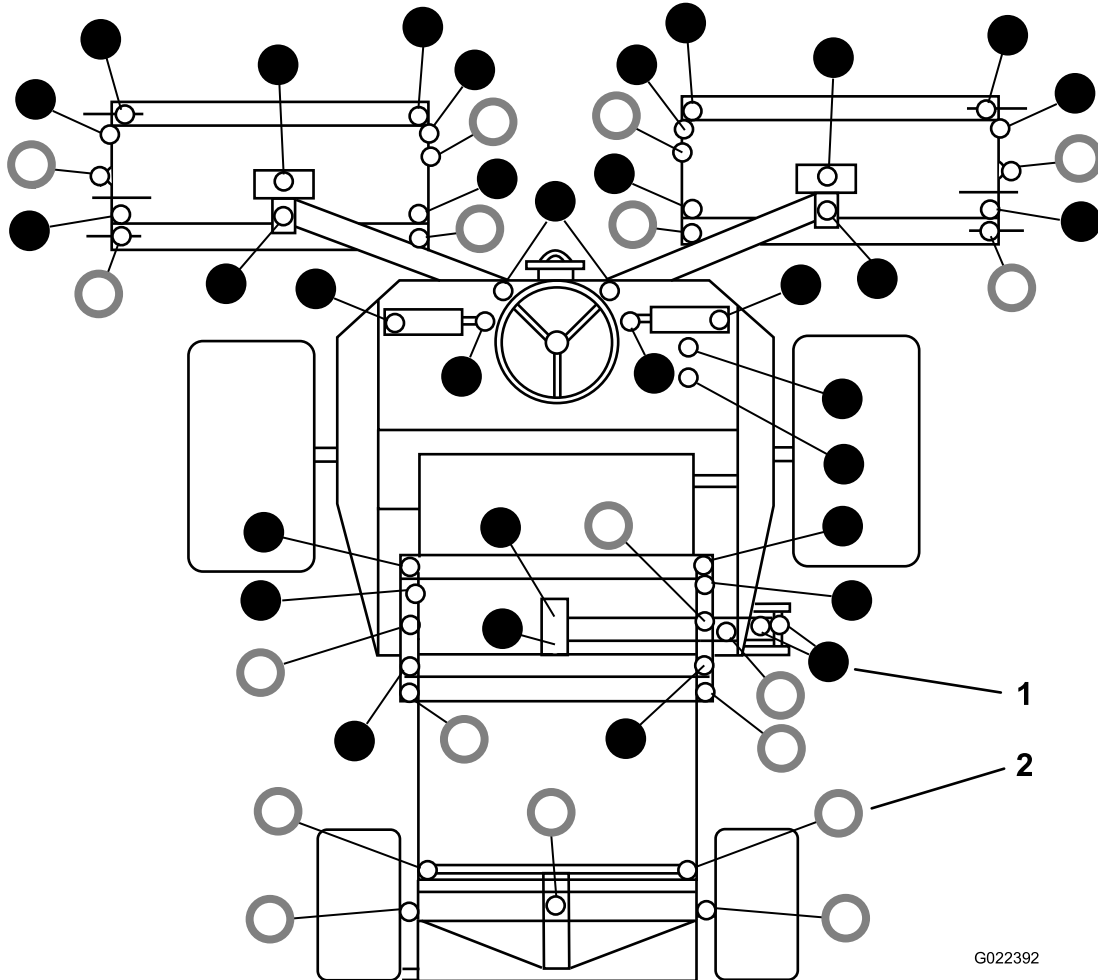

Figure 39

1. ● – Grease every 50 hours

2. ○ – Grease daily

Engine Maintenance

Engine Safety

- Shut off the engine before checking the oil or adding oil to the crankcase.
- Do not change the governor speed or overspeed the engine.

Checking the Engine Overheat Warning System

Service Interval: Every 500 hours

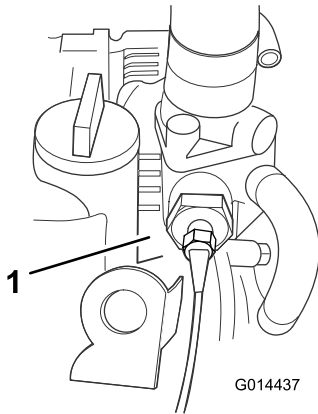

Figure 40

1. Temperature switch

1. Turn the ignition key to the ignition on position I.
2. Disconnect the red/blue wire terminal from the engine temperature switch.
3. Touch the metal terminal of this wire onto a suitable ground point, ensuring that the metal surfaces make good contact.

The horn will sound and the engine coolant temperature warning light will illuminate to confirm correct operation. If the system is malfunctioning, make repairs before operating the mower.

Servicing the Air Cleaner

Service Interval: Before each use or daily
Every 500 hours

Servicing the Primary Air Filter

Check the air-cleaner body for damage which could cause an air leak. Replace if damaged. Check the whole intake system for leaks, damage or loose hose clamps.

Service the primary air-cleaner filter only when the service indicator ([Figure 41](#)) requires it. Changing the air filter before it is necessary only increases the chance of dirt entering the engine when the filter is removed.

Important: Be sure that the cover is seated correctly and seals with the air-cleaner body.

1. Check the filter blockage indicator. If the indicator is red, the air filter needs to be replaced ([Figure 41](#)).

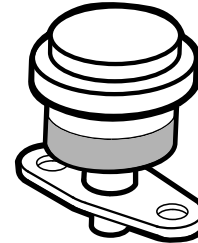

G014565

g014565

Figure 41

2. Before removing the filter, use low pressure air (40 psi, clean and dry) to help remove large accumulations of debris packed between outside of the filter and the canister. **Avoid using high pressure air which could force dirt through the filter into the intake tract.** Remove the cover from the air-cleaner body.

This cleaning process prevents debris from migrating into the intake when the filter is removed.

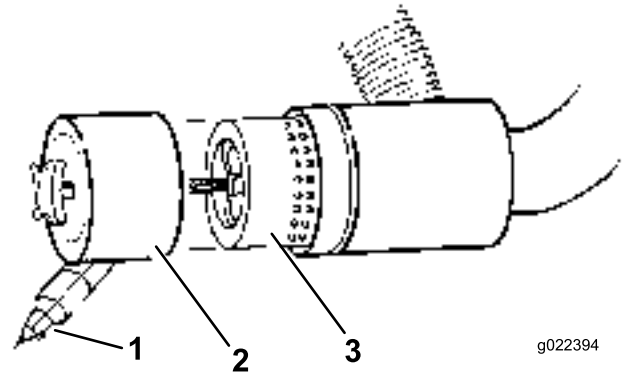

g022394

g022394

Figure 42

1. Dust boot
2. Dust bowl
3. Air filter

3. Remove and replace the filter ([Figure 42](#)).

Cleaning of the used element is not recommended due to the possibility of damage to the filter media.

4. Inspect the new filter for shipping damage, checking the sealing end of the filter and the body. **Do not use a damaged element.**

5. Insert the new filter by applying pressure to the outer rim of the element to seat it in the canister. **Do not apply pressure to the flexible center of the filter.**
6. Clean the dirt ejection port located in the removable cover. Remove the rubber outlet valve from the cover, clean the cavity and replace the outlet valve.
7. Install the cover orienting the rubber outlet valve in a downward position—between approximately 5:00 to 7:00 when viewed from the end.
8. Check the condition of the air cleaner hoses.
9. Secure the cover.

Servicing the Safety Filter

The air filter has a secondary, safety filter element inside the primary air filter to prevent dislodged dust and other items from entering the engine while changing the main element.

Replace the safety filter, never clean it.

Important: Never attempt to clean the safety filter. If the safety filter is dirty, then the primary filter is damaged. Replace both filters.

Checking the Engine-Oil Level

Service Interval: Before each use or daily

The engine is shipped with oil in the crankcase; however, the oil level must be checked before and after the engine is first started.

Crankcase capacity: approximately 6.0 L (6.3 US qt) with the filter

Use high-quality engine oil that meets the following specifications:

- API Classification Level Required: CH-4, CI-4 or higher
- Preferred oil: SAE 15W-40 (above 0 degrees F)
- Alternate oil: SAE 10W-30 or 5W-30 (all temperatures)

Toro Premium Engine oil is available from your distributor in either 15W-40 or 10W-30 viscosity.

Note: The best time to check the engine oil is when the engine is cool before it has been started for the day. If it has already been run, allow the oil to drain back down to the sump for at least 10 minutes before checking. If the oil level is at or below the **add** mark on the dipstick, add oil to bring the oil level to the **full** mark. **Do not overfill the crankcase.** If the oil level

is between the **full** and **add** marks, no oil addition is required.

1. Park the machine on a level surface, shut off the engine, engage the parking brake, and remove the key from the ignition switch.
2. Open the hood.
3. Remove the dipstick, wipe it clean, and install it (Figure 43).

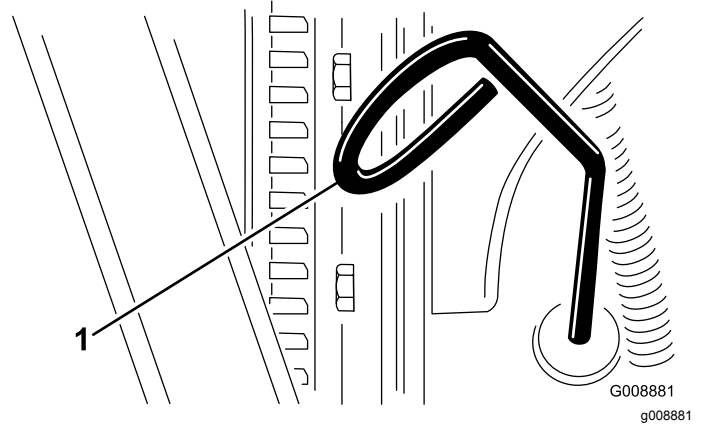

Figure 43

1. Dipstick

4. Remove dipstick and check oil level on dipstick. The oil level should be up to the Full mark .
5. If the oil level is below the Full mark, remove the fill cap (Figure 44) and add oil until level reaches the Full mark on dipstick. **Do not overfill.**

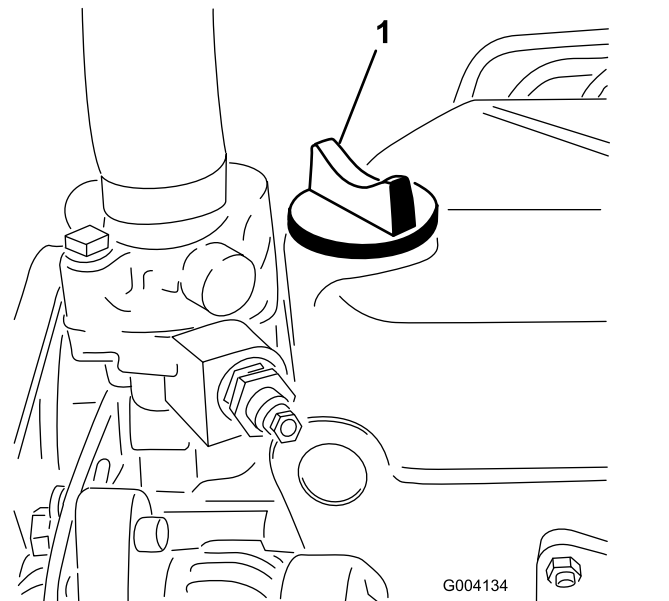

Figure 44

1. Oil fill cap

6. Install the oil fill cap and close the hood.

Servicing the Engine Oil and Filter

6. Add oil to the crankcase; refer to [Checking the Engine-Oil Level \(page 34\)](#).

Service Interval: After the first 50 hours

Every 150 hours

1. Remove the drain plug ([Figure 45](#)) and let the oil flow into a drain pan.

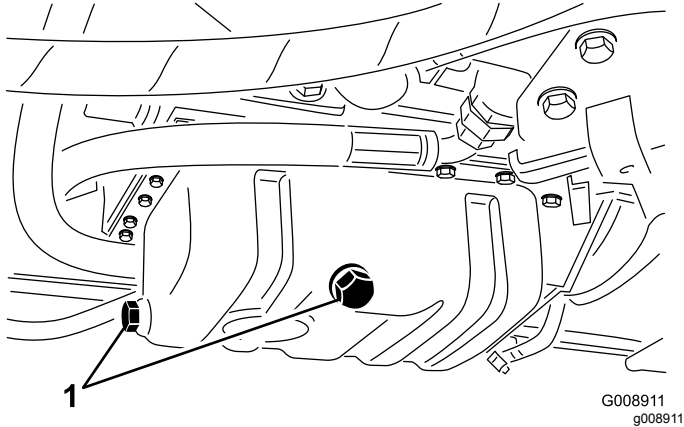

Figure 45

1. Oil drain plug

-
2. When the oil stops, install the drain plug.
 3. Remove the oil filter ([Figure 46](#)).

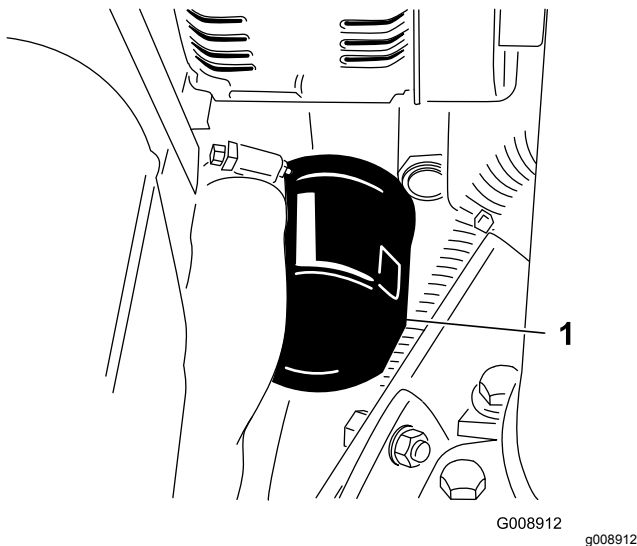

Figure 46

1. Oil filter

-
4. Apply a light coat of clean oil to the new filter seal.
 5. Install the replacement oil filter to the filter adapter. Turn the oil filter clockwise until the rubber gasket contacts the filter adapter, then tighten the filter an additional 1/2 turn.

Important: Do not over-tighten the filter.

Fuel System Maintenance

⚠ DANGER

Under certain conditions, fuel and fuel vapors are highly flammable and explosive. A fire or explosion from fuel can burn you and others and can cause property damage.

- Fill the fuel tank outdoors, in an open area, when the engine is off and is cold. Wipe up any fuel that spills.
- Do not fill the fuel tank completely full. Add fuel to the fuel tank until the level is 25 mm (1 inch) below the top of the tank, not the filler neck. This empty space in the tank allows the fuel to expand.
- Never smoke when handling fuel, and stay away from an open flame or where fuel fumes may be ignited by a spark.
- Store fuel in a clean, safety-approved container and keep the cap in place.

Draining the Fuel Tank

Service Interval: Every 800 hours
Before storage

Drain and clean the fuel tank if the fuel system becomes contaminated or if the machine is to be stored for an extended period. Use clean fuel to flush out the tank.

Checking the Fuel Lines and Connections

Service Interval: Every 400 hours/Yearly (whichever comes first)

Check the fuel lines and connections. Inspect them for deterioration, damage, or loose connections.

Bleeding the Fuel System

You must bleed the fuel system before starting the engine if any of the following situations have occurred:

- Initial start up of a new machine.
- Engine has ceased running due to lack of fuel.
- Maintenance has been performed upon fuel system components; i.e., filter replaced, separator serviced, etc.

⚠ DANGER

Under certain conditions, fuel and fuel vapors are highly flammable and explosive. A fire or explosion from fuel can burn you and others and can cause property damage.

- Use a funnel and fill the fuel tank outdoors, in an open area, when the engine is off and is cold. Wipe up any fuel that spills.
 - Do not fill the fuel tank completely full. Add fuel to the fuel tank until the level is 6 to 12 mm (1/4 to 1/2 inches) below the bottom of the filler neck. This empty space in the tank allows the fuel to expand.
 - Never smoke when handling fuel, and stay away from an open flame or where fuel fumes may be ignited by a spark.
 - Store fuel in a clean, safety-approved container and keep the cap in place.
1. Park the machine on a level surface and ensure that the fuel tank is at least half full.
 2. Open the hood.
 3. Turn the key in the ignition switch to the ON position and crank the engine. The mechanical pump will suck fuel out of the tank, fill the fuel filter and fuel hose and force the air into the engine. This could take some time to fully purge all the air out of the system and the engine might fire erratically until all air is purged out. When all air is purged and the engine is running smoothly, it should be run for a few minutes to ensure that it is fully purged.

Replacing the Fuel Filter

Service Interval: Every 500 hours

Important: Replace the fuel filter canister periodically to prevent wear of the fuel injection pump plunger or the injection nozzle, due to dirt in the fuel.

1. Place a clean container under the fuel filter canister (Figure 47).
2. Clean the area where the filter canister mounts.

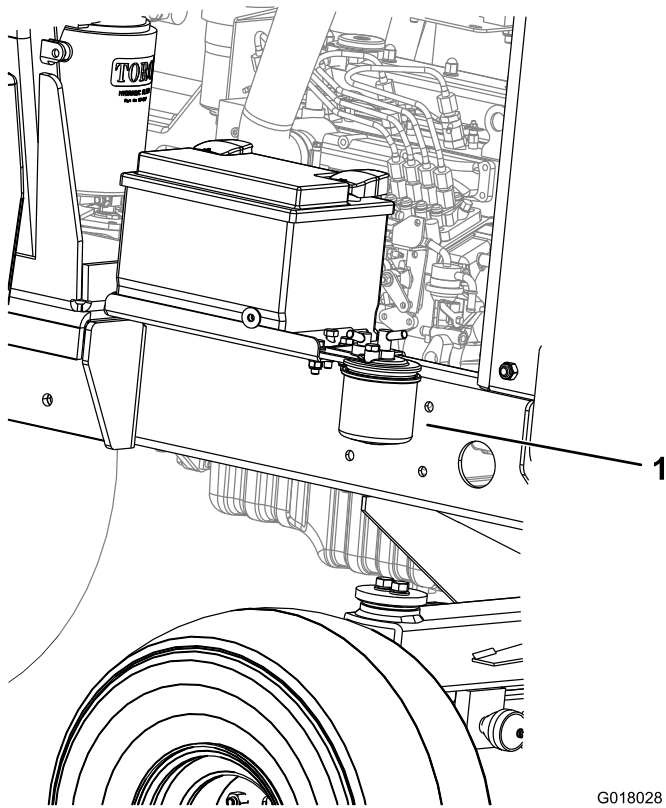

Figure 47

G018028
g018028

1. Fuel filter

3. Remove the filter canister and clean the mounting surface.
4. Lubricate the gasket on the filter canister with clean oil.
5. Install the new filter canister by hand until the gasket contacts mounting surface.
6. Bleed the fuel system; refer to Bleeding the Fuel System.

Electrical System Maintenance

Electrical System Safety

- Disconnect the battery before repairing the machine. Disconnect the negative terminal first and the positive last. Connect the positive terminal first and the negative last.
- Charge the battery in an open, well-ventilated area, away from sparks and flames. Unplug the charger before connecting or disconnecting the battery. Wear protective clothing and use insulated tools.

Checking the Electrical System

Service Interval: Every 500 hours

Inspect all electrical connections and cables and replace any which are damaged or corroded. Spray a good-quality water inhibitor onto exposed connections to prevent moisture ingress.

Checking the Battery Condition

Service Interval: Every 250 hours

Note: When removing the battery, always disconnect the negative (-) cable first.

Note: When installing the battery, always connect the negative (-) cable last.

Raise the engine cover. Remove any corrosion from the battery terminals using a wire brush and apply petroleum jelly to the terminals to prevent further corrosion. Clean the battery compartment.

Under normal operating conditions the battery will not require any further attention. If the machine has been subject to continuous use under high ambient temperature conditions, the battery electrolyte may require topping up.

Remove the cell covers and top up with distilled water to a height 15 mm below the top of the battery. Install the cell covers.

Note: Check the condition of the battery cables. Install new cables when current ones are showing signs of wear or damage and tighten any loose connections as necessary.

Servicing the Battery

Service Interval: Every 250 hours

⚠ DANGER

Battery electrolyte contains sulfuric acid which is a deadly poison and causes severe burns.

- Do not drink electrolyte and avoid contact with skin, eyes, or clothing. Wear safety glasses to shield your eyes and rubber gloves to protect your hands.
- Fill the battery where clean water is always available for flushing the skin.

⚠ WARNING

Charging the battery produces gasses that can explode.

Never smoke near the battery and keep sparks and flames away from it.

Check the battery condition. Keep the terminals and the entire battery case clean because a dirty battery will discharge slowly. To clean the battery, wash the entire case with a solution of baking soda and water. Rinse it with clear water.

Drive System Maintenance

Checking the Tire Pressure

Check the air pressure in the front and rear tires. Refer to the chart below for the correct pressure.

Important: Maintain correct tire pressure in all tires to ensure correct contact with the turf.

Tires	Tire Type	Recommended Tire Pressures		
		Turf Conditions	Road Conditions	Maximum Pressure
Front Axle	26 x 12.0 - 12 BKT turf pattern	0.7 bar (10 psi)	1.4 bar (20 psi)	1.7 bar (25 psi)
Rear Axle	20 x 10.0 - 8 BKT turf pattern	0.7 bar (10 psi)	1.4 bar (20 psi)	1.7 bar (25 psi)

Checking the Torque of the Wheel Nuts

Service Interval: Before each use or daily

Torque the wheel nuts to 200 N-m (148 ft-lb) for the front axle, and 54 N-m (40 ft-lb) for the rear axle.

⚠ WARNING

Failure to maintain proper torque of the wheel nuts could result in personal injury.

Ensure that the wheel nuts are torqued properly.

Changing the Transmission Oil Filter

Service Interval: After the first 50 hours

Every 500 hours

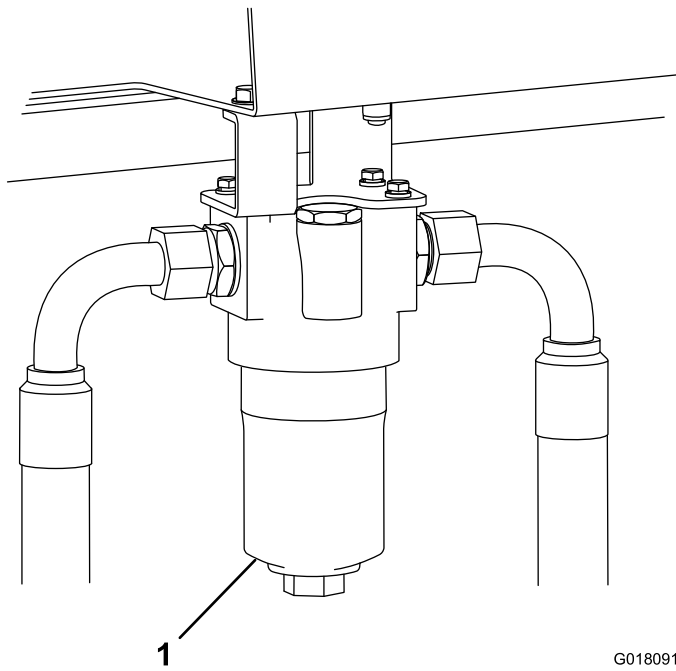

Figure 48

Right side of machine

1. Transmission oil filter

1. Unscrew and remove the bottom of the transmission oil filter housing.
2. Withdraw the filter element and discard it.
3. Install a new filter element (Part 924709).
4. Install the housing.

Checking the Rear Wheel Alignment

Service Interval: Every 500 hours

To prevent excessive tire wear and ensure safe machine operation, the rear wheels must be correctly aligned to 3 to 8 mm (0.12 to 0.31 inch).

Set the rear wheels in the straight ahead position. Measure and compare the distance between the front sidewalls and the rear sidewalls at the wheel center height. The distance between the front sidewalls must be set 3 to 8 mm (0.12 to 0.31 inch) less than the distance between the rear sidewalls.

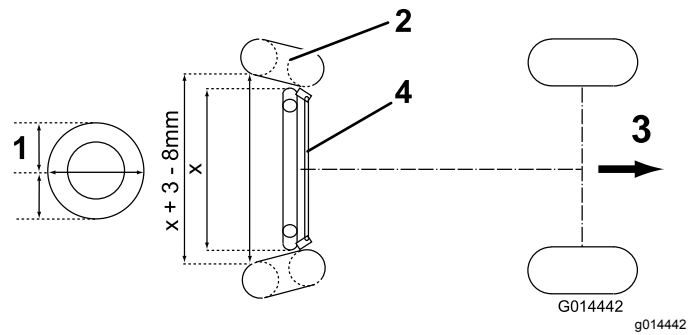

Figure 49

1. Wheel center height
2. Tire
3. Direction of forward travel
4. Track-rod assembly

To adjust the alignment of the rear wheels, first back off the left and right locknuts on the track rod assembly. (Left locknut has left-hand threads). Rotate the track rod to achieve the correct distance as described above and tighten the locknuts securely.

Inspecting the Transmission Control Cable and Operating Mechanism

Service Interval: Every 250 hours

Check the condition and security of the cable and operating mechanism at the speed control pedals and transmission pump ends.

- Remove build up of dirt, grit and other deposits.
- Ensure that the ball joints are securely anchored and check that mounting brackets and cable anchors are tight and free from cracks.
- Inspect end fittings for wear, corrosion, broken springs, and replace if necessary.
- Ensure that the rubber seals are correctly located and are in good condition.
- Ensure that the articulating sleeves supporting the inner cable are in good condition and firmly attached to the outer cable assembly at the crimped connections. If there are any signs of cracking or detachment install a new cable immediately.
- Check that sleeves, rods, and inner cable are free from bends, kinks, or other damage. If they are not, install a new cable immediately.
- With the engine switched off, operate the pedal controls through the entire range and ensure that the mechanism moves smoothly and freely to the neutral position without sticking or hanging up.

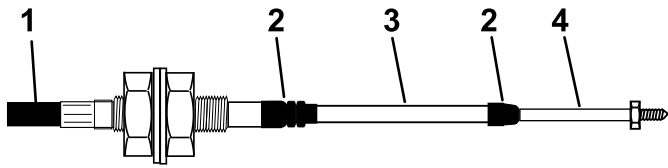

g014571
g014571

Figure 50

- | | |
|----------------|------------|
| 1. Outer cover | 3. Sleeve |
| 2. Rubber seal | 4. Rod end |

Cooling System Maintenance

Cooling System Safety

- Swallowing engine coolant can cause poisoning; keep out of reach from children and pets.
- Discharge of hot, pressurized coolant or touching a hot radiator and surrounding parts can cause severe burns.
 - Always allow the engine to cool at least 15 minutes before removing the radiator cap.
 - Use a rag when opening the radiator cap, and open the cap slowly to allow steam to escape.

Removing Debris from the Cooling System

Service Interval: Before each use or daily

Every 100 hours

Every 2 years

Note: To prevent the engine from overheating, the radiator and oil cooler must be kept clean. Normally, check daily and, if necessary, clean any debris off these parts. However, it will be necessary to check and clean more frequently in extremely dusty and dirty conditions.

1. Park the machine on a level surface, shut off the engine, engage the parking brake, and remove the key from the ignition switch.
2. Clean the radiator screen.
3. Thoroughly clean all debris out of the engine area.
4. Release the latch and open the engine cover (Figure 51).

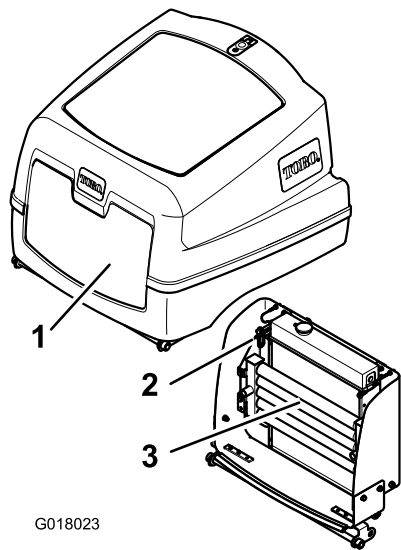

G018023

Figure 51

1. Engine cover
2. Oil cooler release clip
3. Oil cooler

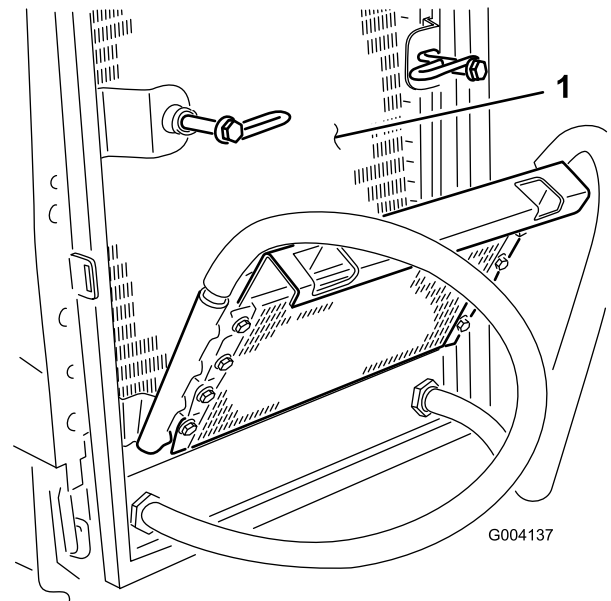

G004137

Figure 53

1. Radiator

g004137

5. Clean the screen thoroughly with compressed air.
6. Pivot the latch inward to release the oil cooler ([Figure 52](#)).

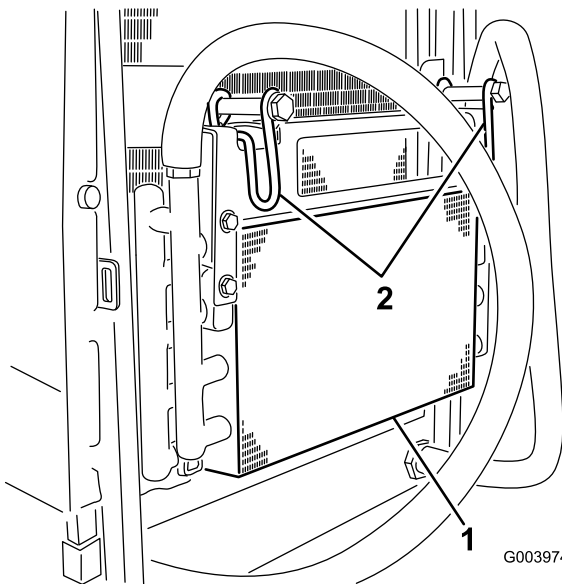

G003974

Figure 52

g003974

1. Oil cooler
2. Oil cooler latch

7. Working from the fan side of the radiator, blow out debris with low pressure (50 psi) compressed air (do not use water). Repeat the step from the front of the radiator and again from the fan side. Thoroughly clean both sides of the oil cooler. After the radiator and oil coolers are thoroughly cleaned, clean out any debris that may have collected on other parts of the machine ([Figure 53](#)) with compressed air.

Belt Maintenance

Check the condition and tension of the alternator belt after the first day of operation and every 100 operating hours thereafter.

Tensioning the Alternator Belt

Service Interval: After the first 8 hours

Every 100 hours

1. Open the hood.
2. Check the tension of the alternator belt by pressing it (Figure 54) midway between the alternator and the crankshaft pulleys with 10 kg (22 lb) of force.

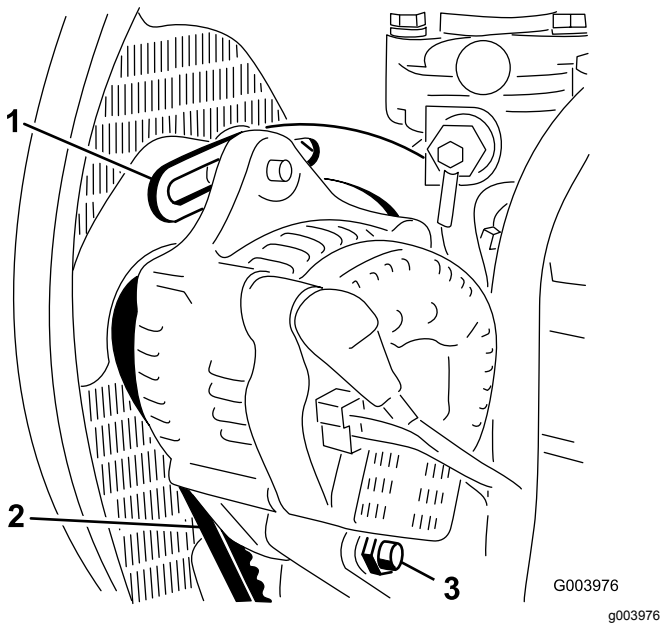

Figure 54

1. Brace
2. Alternator belt
3. Pivot bolt

The belt should deflect 11 mm (7/16 inch). If the deflection is incorrect, proceed to step 3. If correct, continue operation.

3. Loosen the bolt securing the brace to the engine (Figure 54), the bolt securing the alternator to the brace and the pivot bolt.
4. Insert a pry bar between the alternator and the engine and pry out on the alternator.
5. When you achieve the proper tension, tighten the alternator, brace and pivot bolts to secure the adjustment.

Hydraulic System Maintenance

Hydraulic System Safety

- Seek immediate medical attention if fluid is injected into skin. Injected fluid must be surgically removed within a few hours by a doctor.
- Ensure that all hydraulic-fluid hoses and lines are in good condition and all hydraulic connections and fittings are tight before applying pressure to the hydraulic system.
- Keep your body and hands away from pinhole leaks or nozzles that eject high-pressure hydraulic fluid.
- Use cardboard or paper to find hydraulic leaks.
- Safely relieve all pressure in the hydraulic system before performing any work on the hydraulic system.

Checking the Hydraulic Lines and Hoses

Service Interval: Before each use or daily

Check the hydraulic lines and hoses for leaks, kinked lines, loose mounting supports, wear, loose fittings, weather deterioration, and chemical deterioration. Make all necessary repairs before operating.

Checking the Hydraulic Fluid

The reservoir is filled at the factory with approximately 32 L (8.5 US gallons) of high-quality hydraulic fluid. The best time to check the hydraulic oil is when the fluid is cold. The machine should be in its transport configuration. If the oil level is below the 'add' mark on the dipstick, add oil to bring the oil level to the middle of the acceptable range. **Do not overfill the reservoir.** If the oil level is between the 'full' and the 'add' marks, no oil addition is required.

The recommended replacement fluid is:

Toro Premium All Season Hydraulic Fluid

(available in 19 liter (5 US gallon) containers or 208 liter (55 US gallon) drums—see the parts documentation or your Toro distributor for part numbers)

Alternative fluids: If the Toro fluid is not available, other conventional, petroleum-based fluids may be used, provided that they meet all of the following material properties and industry specifications. Check

with your oil supplier to see whether the oil meets these specifications.

Note: Toro will not assume responsibility for damage caused by improper substitutions, so use only products from reputable manufacturers who will stand behind their recommendation.

High Viscosity Index/Low Pour Point Antiwear Hydraulic Fluid, ISO VG 46 Multigrade

Material Properties:

Viscosity, ASTM D445	cSt @ 40°C (104°F) 44 to 48 cSt @ 100°C (212°F) 7.9 to 9.1
Viscosity index, ASTM D2270	140 or higher (high viscosity index indicates a multiweight fluid)
Pour point, ASTM D97	-36.7°C to -45°C (-34°F to -49°F)
FZG, fail stage	11 or better
Water content (new fluid)	500 ppm (maximum)

Industry Specifications:

Vickers I-286-S, Vickers M-2950-S, Denison HF-0, Vickers 35 VQ 25 (Eaton ATS373-C)

The proper hydraulic fluids must be specified for mobile machinery (as opposed to industrial plant usage), multiweight-type, with ZnDTP or ZDDP antiwear additive package (not an ashless-type fluid).

Important: Many hydraulic fluids are almost colorless, making it difficult to spot leaks. A red dye additive for the hydraulic system oil is available in 20 ml (2/3 fl oz) bottles. One bottle is sufficient for 15 to 22 liters (4 to 6 US gallons) of hydraulic oil. Order part 44-2500 from your Authorized Toro Distributor.

Synthetic, Biodegradable Hydraulic Fluid

(available in 19 liter (5 US gallon) containers or 208 liter (55 US gallon) drums—see the parts documentation or your Toro distributor for part numbers)

This high-quality, synthetic, biodegradable fluid has been tested and found compatible for this Toro model. Other brands of synthetic fluid may have seal compatibility problems and Toro cannot assume responsibility for unauthorized substitutions.

Note: This synthetic fluid is not compatible with the Toro Biodegradable Fluid previously sold. See your Toro Distributor for more information.

Alternative fluids:

- Mobil EAL EnviroSyn H 46 (US)
 - Mobil EAL Hydraulic Oil 46 (international)
1. Park the machine on a level surface, lower the cutting units, shut off the engine, engage the parking brake, and remove the key.
 2. Check the sight level gauge on the side of the tank.

Note: The level needs to be at the upper mark.

3. If additional hydraulic oil is needed, clean the area around the filler neck and the cap of the hydraulic tank (Figure 55) and remove the cap.

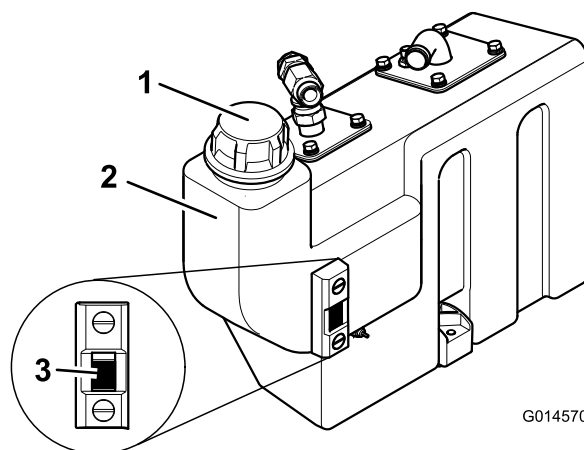

Figure 55

1. Hydraulic-tank cap
2. Fluid tank
3. Sight level gauge

4. Remove the cap and fill the tank to the upper mark on the sight level gauge.

Note: Do not overfill the tank.

5. Install the cap onto the tank.

Changing the Hydraulic Return Filter

Service Interval: After the first 50 hours

Every 500 hours

1. Remove the return filter.
2. Wipe oil onto the new return filter gasket.
3. Install the new return filter to the machine.

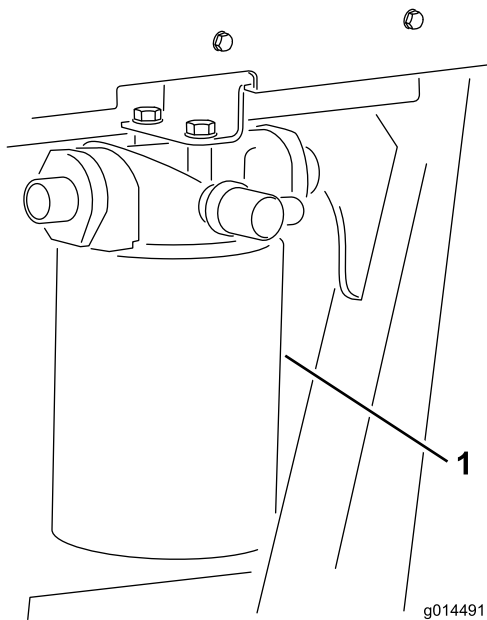

Figure 56

Left side of machine

1. Hydraulic oil return filter

Servicing the Hydraulic System

Service Interval: Every 500 hours

Note: Keep water away from electrical components. Use a dry cloth or brush to clean such areas.

This procedure is best carried out when the hydraulic fluid is warm (not hot). Lower the cutting units to the ground and drain the hydraulic system.

1. Remove the fluid tank filler flange to gain access to the suction strainer.
2. Unscrew and remove the strainer and clean with paraffin/kerosene or gasoline before installing.
3. Install the return line fluid filter element.
4. Install the transmission fluid filter element.
5. Fill the hydraulic tank with fresh clean hydraulic fluid of the recommended grade.
6. Run the machine and operate all hydraulic systems until the hydraulic fluid is warm.
7. Check the fluid level and top up as necessary to the upper mark on the sight level gauge.

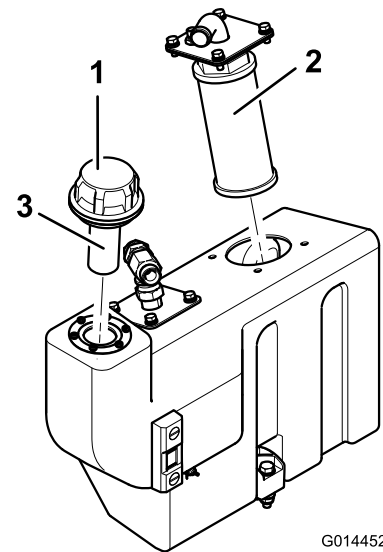

Figure 57

1. Fluid-tank filler cap
2. Suction strainer
3. Filler strainer

Checking the Hydraulic Fluid Overheat Warning System

Service Interval: Every 500 hours

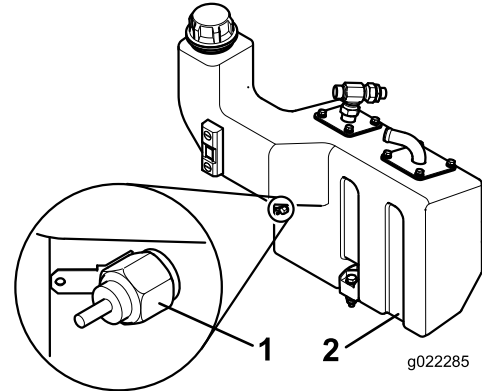

Figure 58

1. Temperature switch
2. Hydraulic-fluid tank

1. Turn the ignition key to the ignition on position I.
2. Disconnect the red/yellow wire terminal from the hydraulic tank temperature switch.
3. Touch the metal terminal of the wire onto a suitable ground point, ensuring that the metal surfaces make good contact.

The horn will sound and the hydraulic fluid temperature warning light will illuminate to confirm correct operation. If necessary, make repairs before operating the mower.

Checking the Hydraulic Lines and Hoses

Daily, check hydraulic lines and hoses for leaks, kinked lines, loose mounting supports, wear, loose fittings, weather deterioration, and chemical deterioration. Make all necessary repairs before operating.

Cutting Unit Maintenance

Refer to the cutting unit *Operator's Manual* for maintenance procedures.

Blade Safety

- A worn or damaged blade or bedknife can break, and a piece could be thrown toward you or bystanders, resulting in serious personal injury or death.
- Inspect the cutting units periodically for excessive wear or damage.
- Use care when checking the cutting units. Wrap the blades or wear gloves, and use caution when servicing the reels and bedknives. Only replace or sharpen the reels and bedknives; never straighten or weld them.
- On machines with multiple cutting units, take care when rotating a reel; it can cause the reels in the other cutting units to rotate.

Back Lapping the Cutting Units

⚠ WARNING

Contact with the cutting units or other moving parts can result in personal injury.

- **Keep fingers, hands, and clothing away from the cutting units or other moving parts.**
- **Never attempt to turn the cutting units by hand or foot while the engine is running.**

This process is recommended for restoring the sharp cutting edges to reels and bedknives which are essential for good-quality grass cutting.

This process can only deal with a small amount of metal removal to restore the cutting edges. If the blade edges are seriously worn or damaged it will be necessary to remove the component parts and have them ground again.

1. Ensure that the mower engine is shut off and that the parking brake is engaged.
2. Adjust the reels to the bedknives to obtain light contact.
3. Apply a medium-grade detergent-based carborundum paste to the cutting edges of the reels with a long-handled brush.

80-grade carborundum paste	
	Part number
0.45 kg (1 lb)	63-07-088
11.25 kg (25 lb)	63-07-086

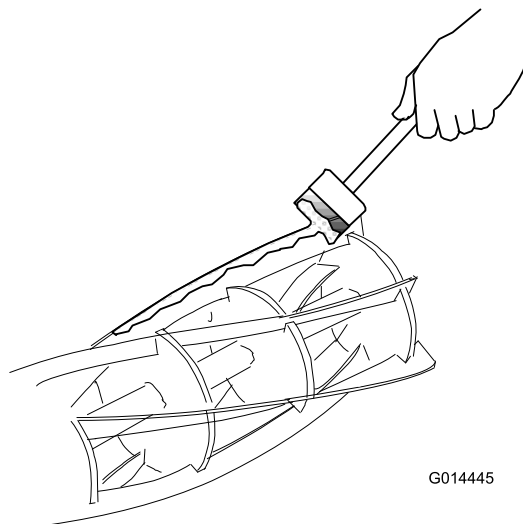

Figure 59

g014445

Grinding the Cutting Units

It will be necessary to carry out a grinding operation to correct reel edges or bedknife edges that have become excessively rounded or distorted. Bedknives that are nearing the end of their wear life should be replaced. The new blades should be ground on their holders prior to fitting. When grinding operations are necessary it is essential that both the reels and the bedknives are ground at the same time. The only exception to this rule is when a new reel is fitted, in which case it is only necessary to grind the bedknife. All such grinding operations should be carried out by your authorized dealer on a quality, well-maintained reel / bedknife grinding machine

- Sit on the operator seat, start the engine, and set the engine speed to idle.

⚠ WARNING

If you touch the cutting units when the engine is running, you could be seriously injured.

- **Ensure that the area surrounding the cutting units is clear of people.**
 - **Keep hands and feet clear of the cutting units during the period when the mower engine is running.**
- Operate the cutting unit drive switch to the reverse/back lap position for a period of time and listen to the grinding action.
 - Operate the cutting unit drive switch to the off position and shut off the engine when the grinding action has stopped.
 - Thoroughly clean the blade edges and adjust the bedknives to the reels.
 - Check that a thin piece of paper can be cut cleanly at all points along the cutting edges while rotating the reels by hand.
 - If further back lapping is necessary repeat steps 2 through 8.
 - Thoroughly remove and wash off all traces of the carborundum paste from the reels and bedknives.

Cleaning

Washing the Machine

Wash the machine as needed using water alone or with a mild detergent. You may use a rag when washing the machine.

Important: Do not use brackish or reclaimed water to clean the machine.

Important: Do not use power-washing equipment to wash the machine. Power-washing equipment may damage the electrical system, loosen important decals, or wash away necessary grease at friction points. Avoid excessive use of water near the control panel, engine, and battery.

Important: Do not wash the machine with the engine running. Washing the machine with the engine running may result in internal engine damage.

Storage

Storage Safety

- Shut off the engine, remove the key, wait for all movement to stop before you leave the operator's position. Allow the machine to cool before adjusting, servicing, cleaning, or storing it.
- Do not store the machine or fuel container where there is an open flame, spark, or pilot light, such as on a water heater or on other appliances.

Preparing the Traction Unit

1. Park the machine on a level surface, lower the cutting units, engage the parking brake, shut off the engine, and remove the key.
2. Thoroughly clean the traction unit, cutting units, and the engine.
3. Check the tire pressure; refer to [Checking the Tire Pressure \(page 38\)](#).
4. Check all fasteners for looseness; tighten them as necessary.
5. Grease or oil all grease fittings and pivot points. Wipe up any excess lubricant.
6. Lightly sand and use touch-up paint on painted areas that are scratched, chipped, or rusted. Repair any dents in the metal body.
7. Service the battery and cables as follows; refer to [Electrical System Safety \(page 37\)](#):
 - A. Remove the battery terminals from the battery posts.
 - B. Clean the battery, terminals, and posts with a wire brush and baking-soda solution.
 - C. Coat the cable terminals and battery posts with Grafo 112X skin-over grease (Toro Part No. 505-47) or petroleum jelly to prevent corrosion.
 - D. Slowly charge the battery every 60 days for 24 hours to prevent lead sulfation of the battery.

Preparing the Engine

1. Drain the engine oil from the oil pan and install the drain plug.
2. Remove and discard the oil filter. Install a new oil filter.
3. Fill the engine with specified motor oil.
4. Start the engine and run it at idle speed for approximately 2 minutes.
5. Shut off the engine and remove the key.

6. Flush the fuel tank with fresh, clean fuel.
7. Secure all of the fuel-system fittings.
8. Thoroughly clean and service the air-cleaner assembly.
9. Seal the air-cleaner inlet and the exhaust outlet with weatherproof tape.
10. Check the antifreeze protection and add a 50/50 solution of water and ethylene glycol antifreeze as needed for the expected minimum temperature in your area.

Troubleshooting

Problem	Possible Cause	Corrective Action
There are areas of uncut grass at the overlap between cutting units.	<ol style="list-style-type: none"> 1. You are turning too tightly. 2. The machine slides sideways when travelling across the face of a slope. 3. There is no ground contact on 1 end of the cutting unit because of poorly routed hoses or wrongly positioned hydraulic adapters. 4. There is no ground contact on 1 end of the cutting unit because a pivot pin is seizing. 5. There is no ground contact on 1 end of the cutting unit because of grass buildup under the cutting unit. 	<ol style="list-style-type: none"> 1. Increase the turning radius. 2. Mow up/down the slope. 3. Correct the hose routing or the position of the hydraulic adapters. 4. Release and grease the pivot points. 5. Clear the grass buildup.
There are full-width ridge lines in the cut across the direction of travel.	<ol style="list-style-type: none"> 1. The forward speed is too high. 2. The reel speed is too slow. 3. The height of cut is too low. 	<ol style="list-style-type: none"> 1. Reduce forward speed. 2. Increase the mower engine speed. 3. Raise the height of cut.
There are ridge lines in the cut grass, across the direction of travel, over the cutting width of 1 cutting unit.	<ol style="list-style-type: none"> 1. A reel is running slow. 	<ol style="list-style-type: none"> 1. Check the reel speed; consult your authorized distributor.
There is a step in the cut grass height at the point of overlap between cutting units.	<ol style="list-style-type: none"> 1. There is an inconsistent height-of-cut setting on 1 cutting unit. 2. The raise/lower position control is not in the float position. 3. There is no ground contact on 1 end of the cutting unit because of poorly routed hoses or wrongly positioned hydraulic adapters. 4. There is no ground contact on 1 end of the cutting unit because of pivot pins seizing. 5. There is no ground contact on 1 end of the cutting unit because of grass buildup under the cutting unit. 	<ol style="list-style-type: none"> 1. Check and adjust the height-of-cut setting. 2. Set the position control to the float position. 3. Correct the hose routing and the position of the hydraulic adapters. 4. Release and grease the pivot points. 5. Remove the grass buildup.
There are some uncut or poorly cut strands of grass.	<ol style="list-style-type: none"> 1. A reel is partially out of contact with the bedknife. 2. A reel is in heavy contact with the bedknife. 3. The height of cut is too high. 4. The cutting edges of the reels/bedknives are rounded. 	<ol style="list-style-type: none"> 1. Adjust the reel-to-bedknife contact. 2. Adjust the reel-to-bedknife contact. 3. Lower the height of cut. 4. Back lap or grind the edges.
There are lines of uncut or badly cut grass in the direction of travel.	<ol style="list-style-type: none"> 1. There is tram lining of the cutting edges due to heavy contact caused by poor reel-to-bedknife adjustment. 2. The bedknife is in contact with the ground. 3. The bedknife has a nose-down angle. 4. The cutting units are bouncing. 5. There are worn reel bearings/bearing housing pivots. 6. There are loose components in the cutting unit. 	<ol style="list-style-type: none"> 1. Back lap or grind the edges. 2. Raise the height of cut. 3. Adjust the cutting unit to position the bedknife parallel to the ground. 4. Reduce the forward speed and reduce the weight transfer. 5. Replace any worn parts. 6. Check and tighten components as necessary.

Problem	Possible Cause	Corrective Action
There is scalping of the turf.	<ol style="list-style-type: none"> 1. The undulations are too severe for the height of cut setting. 2. The height of cut is too low. 	<ol style="list-style-type: none"> 1. Use floating cutting units. 2. Raise the height of cut.
There is excessive bedknife wear.	<ol style="list-style-type: none"> 1. The bedknife is in heavy contact with the ground. 2. The cutting edges of the reel and/or bedknife are rounded. 3. The reel is in heavy contact with the bedknife. 4. There is a damaged reel or bedknife. 5. There are excessively abrasive ground conditions. 	<ol style="list-style-type: none"> 1. Raise the height of cut. 2. Back lap or grind the edges. 3. Adjust the reel-to-bedknife contact. 4. Grind or replace parts as necessary. 5. Raise the height of cut.
The engine does not start with the ignition key.	<ol style="list-style-type: none"> 1. The transmission neutral interlock switch is not energized. 2. The parking brake interlock switch is not energized. 3. The cutting unit drive interlock switch is not energized. 4. There is a malfunctioning electrical connection. 	<ol style="list-style-type: none"> 1. Remove your foot from the forward/reverse pedals or check the setting of the transmission neutral interlock switch. 2. Move the parking brake switch to the on position. 3. Move the cutting unit switch to the off position. 4. Locate and correct the fault in the electrical system.
The battery has no power.	<ol style="list-style-type: none"> 1. A terminal connection is loose or corroded. 2. The alternator belt is loose or worn. 3. The battery is discharged. 4. There is an electrical short circuit. 	<ol style="list-style-type: none"> 1. Clean and tighten the terminal connections. Charge the battery. 2. Adjust the tension or replace the belt; refer to engine operator's manual. 3. Charge or replace the battery. 4. Locate the short circuit and fix it.
The hydraulic fluid is overheating.	<ol style="list-style-type: none"> 1. There is a blocked screen. 2. The fluid cooler fins are dirty/blocked. 3. The engine radiator is dirty/blocked. 4. The relief valve setting is low. 5. The fluid level is low. 6. The brakes are engaged. 7. The reels are tight on the bedknives. 8. There is a malfunctioning fan or fan drive. 	<ol style="list-style-type: none"> 1. Clean the screen. 2. Clean the fins. 3. Clean the radiator. 4. Have the relief valve pressure checked. Consult your authorized distributor. 5. Fill the reservoir to the correct level. 6. Disengage the brakes. 7. Adjust the settings. 8. Check the fan operation and service it as required.
The brake system does not operate correctly.	<ol style="list-style-type: none"> 1. There is a malfunctioning wheel motor brake assembly. 2. The brake discs are worn. 	<ol style="list-style-type: none"> 1. Consult your authorized distributor. 2. Replace the brake discs; consult your authorized distributor.
There is a lack of steering.	<ol style="list-style-type: none"> 1. The steering valve is malfunctioning. 2. A hydraulic cylinder is malfunctioning. 3. A steering hose is damaged. 	<ol style="list-style-type: none"> 1. Service or replace the steering valve. 2. Service or replace the hydraulic cylinder. 3. Replace the hose.

Problem	Possible Cause	Corrective Action
There is no machine movement in forward or reverse.	<ol style="list-style-type: none"> 1. The parking brake is engaged. 2. The fluid level is low. 3. The reservoir has the wrong kind of fluid. 4. The drive pedal linkage is damaged. 5. The transmission pump is damaged. 6. The transmission bypass valve is open. 7. There is a broken drive coupling. 	<ol style="list-style-type: none"> 1. Disengage the parking brake. 2. Fill the reservoir to the correct level. 3. Drain the reservoir and fill it with the correct fluid. 4. Check the linkage and replace any damaged or worn parts. 5. Have the transmission pump overhauled by your authorized distributor. 6. Close the bypass valve. 7. Replace the drive coupling.
The machine creeps forward or backward in neutral.	<ol style="list-style-type: none"> 1. The transmission neutral adjustment is set incorrectly. 	<ol style="list-style-type: none"> 1. Adjust the transmission neutral linkage setting.
There is excessive noise in the hydraulic system.	<ol style="list-style-type: none"> 1. A pump is malfunctioning. 2. A motor is malfunctioning. 3. Air is leaking into the system. 4. A suction strainer is blocked or damaged. 5. The fluid has excessive viscosity due to cold conditions. 6. The relief valve setting is low. 7. The hydraulic fluid level is low. 	<ol style="list-style-type: none"> 1. Identify the noisy pump and service or replace it. 2. Identify the noisy motor and service or replace it. 3. Tighten or replace the hydraulic fittings, particularly in the suction lines. 4. Clean and replace the suction strainer or renew it as necessary. 5. Allow the system to warm up. 6. Have the relief valve pressure checked. Consult your authorized distributor. 7. Fill the hydraulic fluid reservoir to the correct level.
After an initial period of satisfactory operation, the machine loses power.	<ol style="list-style-type: none"> 1. A pump or motor is worn. 2. The hydraulic fluid level is low. 3. The fluid in the hydraulic system has the wrong viscosity. 4. The fluid-filter element is blocked. 5. The pressure relief valve is malfunctioning. 6. The system is overheating. 7. There are leaks on the suction hose. 	<ol style="list-style-type: none"> 1. Replace parts as necessary. 2. Fill hydraulic fluid tank to the correct level. 3. Replace the fluid in the hydraulic tank with the correct viscosity-grade fluid; refer to the Specifications section. 4. Change the filter element. 5. Have the relief valve cleaned and pressure checked. Consult your authorized distributor. 6. Check the reel-to-bedknife adjustment. Reduce the work rate (increase the height of cut or reduce the forward speed). 7. Check and tighten the fittings. Replace the hose if necessary.
A reel 'knocks' while rotating.	<ol style="list-style-type: none"> 1. There is a high spot on the reel or the bedknife due to contact with a foreign object. 2. The reel bearings are worn. 	<ol style="list-style-type: none"> 1. Remove the high spot with a stone and back lap to restore the cutting edges. Severe damage will require grinding. 2. Replace the bearings as necessary.
1 reel rotates slowly.	<ol style="list-style-type: none"> 1. A reel bearing is seized. 2. A motor with incorrect rotation was installed. 3. The motor integral check valve is jammed open. 4. The reel is tight on the bedknife. 5. The motor is worn. 	<ol style="list-style-type: none"> 1. Replace the bearings as necessary. 2. Check the motor and replace it if necessary. 3. Have the check valve cleaned and checked. 4. Adjust the setting. 5. Replace the motor.

Problem	Possible Cause	Corrective Action
A cutting unit fails to lift out of work.	<ol style="list-style-type: none"> 1. There is a lift cylinder seal failure. 2. The pressure relief valve is jammed open or wrongly set. 3. There is a malfunctioning control valve. 4. There is mechanical blockage. 	<ol style="list-style-type: none"> 1. Replace the seals. 2. Have the relief valve pressure checked. Consult your authorized distributor. 3. Overhaul the control valve. 4. Remove the blockage.
The cutting units do not follow the contours of the ground.	<ol style="list-style-type: none"> 1. The hose routing or the orientation of the hydraulic fittings is incorrect. 2. The pivot points are too tight. 3. The mower is being operated in the 'hold' position. 4. The weight transfer is set too high. 	<ol style="list-style-type: none"> 1. Move the cutting units throughout the extremes of movement and observe any tightness in the hoses. Correctly route the hoses and orientate the fittings as necessary. 2. Release and grease the pivot point as necessary. 3. Move the position control switch to 'down / float' position. 4. Reduce the weight transfer.
The cutting units fail to start up when lowered into work.	<ol style="list-style-type: none"> 1. The seat sensor switch is malfunctioning. 2. The hydraulic-fluid level is low. 3. A driveshaft is sheared. 4. The pressure relief valve is jammed open or wrongly set. 5. A cutting unit is jammed. 6. A reel is tight on the bedknife. 7. A cutting unit control valve is in the 'off' position, caused by malfunctioning control valve. 8. A cutting unit control valve is in the 'off' position, caused by an electrical fault. 9. The lift arm proximity switch is incorrectly set. 	<ol style="list-style-type: none"> 1. Check the mechanical and electrical operation of the switch. 2. Fill the hydraulic-fluid reservoir to the correct level. 3. Check the motor and reel driveshafts and replace them if necessary. 4. Have the relief valve pressure checked. Consult your authorized dealer. 5. Clear any jams as necessary. 6. Adjust the setting. 7. Overhaul the control valve. 8. Have the electrical system checked for an electrical fault. 9. Check and adjust the proximity switch.
The reels rotate in the wrong direction.	<ol style="list-style-type: none"> 1. The hoses are connected wrongly. 2. The cutting unit drive switch is connected wrongly. 	<ol style="list-style-type: none"> 1. Check the hydraulic circuit and connect the hoses correctly. 2. Check the electrical connections of the switch.

Notes:

Notes:

EEA/UK Privacy Notice

Toro's Use of Your Personal Information

The Toro Company ("Toro") respects your privacy. When you purchase our products, we may collect certain personal information about you, either directly from you or through your local Toro company or dealer. Toro uses this information to fulfil contractual obligations - such as to register your warranty, process your warranty claim or to contact you in the event of a product recall - and for legitimate business purposes - such as to gauge customer satisfaction, improve our products or provide you with product information which may be of interest. Toro may share your information with our subsidiaries, affiliates, dealers or other business partners in connection these activities. We may also disclose personal information when required by law or in connection with the sale, purchase or merger of a business. We will never sell your personal information to any other company for marketing purposes.

Retention of your Personal Information

Toro will keep your personal information as long as it is relevant for the above purposes and in accordance with legal requirements. For more information about applicable retention periods please contact legal@toro.com.

Toro's Commitment to Security

Your personal information may be processed in the US or another country which may have less strict data protection laws than your country of residence. Whenever we transfer your information outside of your country of residence, we will take legally required steps to ensure that appropriate safeguards are in place to protect your information and to make sure it is treated securely.

Access and Correction

You may have the right to correct or review your personal data, or object to or restrict the processing of your data. To do so, please contact us by email at legal@toro.com. If you have concerns about the way in which Toro has handled your information, we encourage you to raise this directly with us. Please note that European residents have the right to complain to your Data Protection Authority.



The Toro Warranty

Two-Year or 1,500 Hours Limited Warranty

Conditions and Products Covered

The Toro Company and its affiliate, Toro Warranty Company, pursuant to an agreement between them, jointly warrant your Toro Commercial product ("Product") to be free from defects in materials or workmanship for 2 years or 1,500 operational hours*, whichever occurs first. This warranty is applicable to all products with the exception of Aerators (refer to separate warranty statements for these products). Where a warrantable condition exists, we will repair the Product at no cost to you including diagnostics, labor, parts, and transportation. This warranty begins on the date the Product is delivered to the original retail purchaser.

* Product equipped with an hour meter.

Instructions for Obtaining Warranty Service

You are responsible for notifying the Commercial Products Distributor or Authorized Commercial Products Dealer from whom you purchased the Product as soon as you believe a warrantable condition exists. If you need help locating a Commercial Products Distributor or Authorized Dealer, or if you have questions regarding your warranty rights or responsibilities, you may contact us at:

Toro Commercial Products Service Department
Toro Warranty Company
8111 Lyndale Avenue South
Bloomington, MN 55420-1196
952-888-8801 or 800-952-2740
E-mail: commercial.warranty@toro.com

Owner Responsibilities

As the product owner, you are responsible for required maintenance and adjustments stated in your *Operator's Manual*. Repairs for product issues caused by failure to perform required maintenance and adjustments are not covered under this warranty.

Items and Conditions Not Covered

Not all product failures or malfunctions that occur during the warranty period are defects in materials or workmanship. This warranty does not cover the following:

- Product failures which result from the use of non-Toro replacement parts, or from installation and use of add-on, or modified non-Toro branded accessories and products.
- Product failures which result from failure to perform recommended maintenance and/or adjustments.
- Product failures which result from operating the Product in an abusive, negligent, or reckless manner.
- Parts consumed through use that are not defective. Examples of parts which are consumed, or used up, during normal Product operation include, but are not limited to, brake pads and linings, clutch linings, blades, reels, rollers and bearings (sealed or greasable), bed knives, spark plugs, castor wheels and bearings, tires, filters, belts, and certain sprayer components such as diaphragms, nozzles, and check valves.
- Failures caused by outside influence, including, but not limited to, weather, storage practices, contamination, use of unapproved fuels, coolants, lubricants, additives, fertilizers, water, or chemicals.
- Failure or performance issues due to the use of fuels (e.g. gasoline, diesel, or biodiesel) that do not conform to their respective industry standards.
- Normal noise, vibration, wear and tear, and deterioration. Normal "wear and tear" includes, but is not limited to, damage to seats due to wear or abrasion, worn painted surfaces, scratched decals or windows.

Countries Other than the United States or Canada

Customers who have purchased Toro products exported from the United States or Canada should contact their Toro Distributor (Dealer) to obtain guarantee policies for your country, province, or state. If for any reason you are dissatisfied with your Distributor's service or have difficulty obtaining guarantee information, contact your Authorized Toro Service Center.

Parts

Parts scheduled for replacement as required maintenance are warranted for the period of time up to the scheduled replacement time for that part. Parts replaced under this warranty are covered for the duration of the original product warranty and become the property of Toro. Toro will make the final decision whether to repair any existing part or assembly or replace it. Toro may use remanufactured parts for warranty repairs.

Deep Cycle and Lithium-Ion Battery Warranty

Deep cycle and Lithium-Ion batteries have a specified total number of kilowatt-hours they can deliver during their lifetime. Operating, recharging, and maintenance techniques can extend or reduce total battery life. As the batteries in this product are consumed, the amount of useful work between charging intervals will slowly decrease until the battery is completely worn out. Replacement of worn out batteries, due to normal consumption, is the responsibility of the product owner. Note: (Lithium-Ion battery only): Pro-rated after 2 years. Refer to the battery warranty for additional information.

Lifetime Crankshaft Warranty (ProStripe 02657 Model Only)

The ProStripe which is fitted with a genuine Toro Friction Disc and Crank-Safe Blade Brake Clutch (integrated Blade Brake Clutch (BBC) + Friction Disc assembly) as original equipment and used by the original purchaser in accordance with recommended operating and maintenance procedures, are covered by a Lifetime Warranty against engine crankshaft bending. Machines fitted with friction washers, Blade Brake Clutch (BBC) units and other such devices are not covered by the Lifetime Crankshaft Warranty.

Maintenance is at Owner's Expense

Engine tune-up, lubrication, cleaning and polishing, replacement of filters, coolant, and completing recommended maintenance are some of the normal services Toro products require that are at the owner's expense.

General Conditions

Repair by an Authorized Toro Distributor or Dealer is your sole remedy under this warranty.

Neither The Toro Company nor Toro Warranty Company is liable for indirect, incidental or consequential damages in connection with the use of the Toro Products covered by this warranty, including any cost or expense of providing substitute equipment or service during reasonable periods of malfunction or non-use pending completion of repairs under this warranty. Except for the Emissions warranty referenced below, if applicable, there is no other express warranty. All implied warranties of merchantability and fitness for use are limited to the duration of this express warranty.

Some states do not allow exclusions of incidental or consequential damages, or limitations on how long an implied warranty lasts, so the above exclusions and limitations may not apply to you. This warranty gives you specific legal rights, and you may also have other rights which vary from state to state.

Note Regarding Emissions Warranty

The Emissions Control System on your Product may be covered by a separate warranty meeting requirements established by the U.S. Environmental Protection Agency (EPA) and/or the California Air Resources Board (CARB). The hour limitations set forth above do not apply to the Emissions Control System Warranty. Refer to the Engine Emission Control Warranty Statement supplied with your product or contained in the engine manufacturer's documentation.