



Count on it.

Operator's Manual

**Standard Bucket, High-Volume
Bucket, or Grading Bucket**

TXL 2000 Tool Carrier

Model No. 22546—Serial No. 318000001 and Up

Model No. 22547—Serial No. 318000001 and Up

Model No. 22548—Serial No. 318000001 and Up

Model No. 22576—Serial No. 318000001 and Up



⚠ WARNING

**CALIFORNIA
Proposition 65 Warning**

Use of this product may cause exposure to chemicals known to the State of California to cause cancer, birth defects, or other reproductive harm.

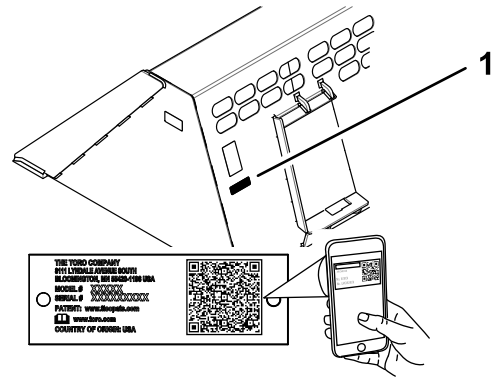

g267815

Figure 2

High volume bucket

1. Model and serial number location

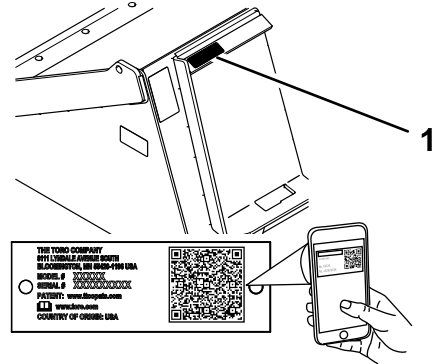

g267814

Figure 3

Grading bucket

1. Model and serial number location

| |
|------------------|
| Model No. _____ |
| Serial No. _____ |

This manual identifies potential hazards and has safety messages identified by the safety-alert symbol (Figure 4), which signals a hazard that may cause serious injury or death if you do not follow the recommended precautions.



g000502

Figure 4

1. Safety-alert symbol

This manual uses 2 words to highlight information. **Important** calls attention to special mechanical information and **Note** emphasizes general information worthy of special attention.

Introduction

The bucket is a load-bearing attachment intended to be used on a Toro tool carrier. It is designed primarily for moving rock, dirt, sand, or other materials. Using this product for purposes other than its intended use could prove dangerous to you and bystanders.

Read this information carefully to learn how to operate and maintain your product properly and to avoid injury and product damage. You are responsible for operating the product properly and safely.

Visit www.Toro.com for product safety and operation training materials, accessory information, help finding a dealer, or to register your product.

Whenever you need service, genuine Toro parts, or additional information, contact an Authorized Service Dealer or Toro Customer Service and have the model and serial numbers of your product ready. Figure 1, Figure 2, or Figure 3 identifies the location of the model and serial numbers on the product. Write the numbers in the space provided.

Important: With your mobile device, you can scan the QR code on the serial number decal (if equipped) to access warranty, parts, and other product information.

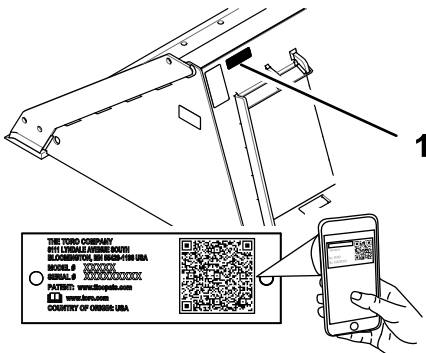

g267816

Figure 1

Standard bucket

1. Model and serial number location

Contents

| | |
|--|---|
| Safety | 3 |
| General Safety | 3 |
| Slope Safety | 4 |
| Bucket Safety | 4 |
| Maintenance and Storage Safety | 4 |
| Safety and Instructional Decals | 5 |
| Product Overview | 6 |
| Specifications | 6 |
| Maximum Material Density at Capacity | 7 |
| Operation | 8 |
| Installing and Removing the Attachment | 8 |
| Filling the Bucket | 8 |
| Transport Position | 9 |
| Storage | 9 |

Safety

⚠ DANGER

There may be buried utility lines in the work area. Digging into them may cause a shock or an explosion.

Have the property or work area marked for buried lines and do not dig in marked areas. Contact your local marking service or utility company to have the property marked (for example, in the US, call 811 or in Australia, call 1100 for the nationwide marking service).

General Safety

Always follow all safety instructions to avoid serious injury or death.

- **Do not transport an attachment with the arms raised or extended;** always transport the attachment close to the ground, with the loader arms retracted; refer to [Transport Position \(page 9\)](#).
- Have the property or work area marked for buried lines and other objects, and do not dig in marked areas.
- Read and understand the content of this *Operator's Manual* before starting the engine.
- Use your full attention while operating the machine. Do not engage in any activity that causes distractions; otherwise, injury or property damage may occur.
- Never allow children or untrained people to operate the machine.
- Keep your hands and feet away from the moving components and attachments.
- Do not operate the machine without the guards and other safety protective devices in place and working on the machine.
- Keep bystanders and pets a safe distance away from the machine.
- Stop the machine, shut off the engine, and remove the key before servicing, fueling, or unclogging the machine.

Improperly using or maintaining this machine can result in injury. To reduce the potential for injury, comply with these safety instructions and always pay attention to the safety-alert symbol **⚠**, which means Caution, Warning, or Danger—personal safety instruction. Failure to comply with these instructions may result in personal injury or death.

You can find additional safety information where needed throughout this *Operator's Manual*.

Slope Safety

- **Operate the machine up and down slopes with the heavy end of the machine uphill.** Weight distribution changes with attachments. An empty load-bearing attachment makes the rear of the machine the heavy end, and a full load-bearing attachment makes the front of the machine the heavy end. Most other attachments make the front of machine the heavy end.
- **Keep the attachment in the lowered position with the loader arms retracted when on slopes.** Raising the attachment or extending the loader arms on a slope affects the stability of the machine.
- Slopes are a major factor related to loss of control and tip-over accidents, which can result in severe injury or death. Operating the machine on any slope or uneven terrain requires extra caution.
- Establish your own procedures and rules for operating on slopes. These procedures must include surveying the site to determine which slopes are safe for machine operation. Always use common sense and good judgment when performing this survey.
- Slow down and use extra care on hillsides. Ground conditions can affect the stability of the machine.
- Avoid starting or stopping on a slope. If the machine loses traction, proceed slowly, straight down the slope.
- Avoid turning on slopes. If you must turn, turn slowly and keep the heavy end of the machine uphill.
- Keep all movements on slopes slow and gradual. Do not make sudden changes in speed or direction.
- If you feel uneasy operating the machine on a slope, do not do it.
- Watch for holes, ruts, or bumps, as uneven terrain could overturn the machine. Tall grass can hide obstacles.
- Use caution when operating on wet surfaces. Reduced traction could cause sliding.
- Evaluate the area to ensure that the ground is stable enough to support the machine.

- Use caution when operating the machine near the following:
 - Drop-offs
 - Ditches
 - Embankments
 - Bodies of water

The machine could suddenly roll over if a track goes over the edge or the edge caves in. Maintain a safe distance between the machine and any hazard.

- Do not remove or add attachments on a slope.
- Do not park the machine on a hillside or slope.

Bucket Safety

- Wear gloves, eye protection, long pants, substantial slip-resistant footwear, and hearing protection during operation or while adjusting or repairing the machine.
- After striking a foreign object, shut off the engine, remove the key, thoroughly inspect the attachment for any damage, and repair the damage before starting and operating the attachment.
- Always lower the attachment and shut off the machine each time you leave the operating position.
- When lifting the attachment, keep it level and prevent the load from spilling backward.

Maintenance and Storage Safety

- Check fasteners at frequent intervals for proper tightness to ensure that the equipment is in safe operating condition.
- Refer to the *Operator's Manual* for important details if you store the attachment for an extended period of time
- Maintain or replace safety and instruction labels, as necessary.

Safety and Instructional Decals



Safety decals and instructions are easily visible to the operator and are located near any area of potential danger. Replace any decal that is damaged or missing.



125-6110

decal125-6110

1. Crushing hazard—do not stand under any part of the machine.

WARNING: Cancer and Reproductive Harm - www.P65Warnings.ca.gov. For more information, please visit www.tcoCAProp65.com

133-8061

decal133-8061

Decal 139-2834 is for Model 22576.

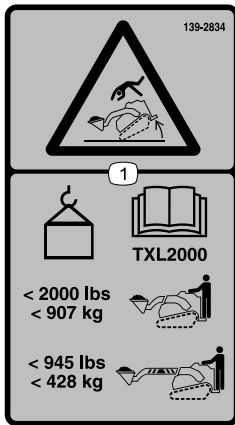

139-2834

decal139-2834

1. Tipping hazard—read the *TXL 2000 Operator's Manual* for load limits; the maximum load with the attachment retracted is 907 kg (2,000 lb); the maximum load with the attachment extended is 428 kg (945 lb).

Decal 139-2836 is for Model 22547.

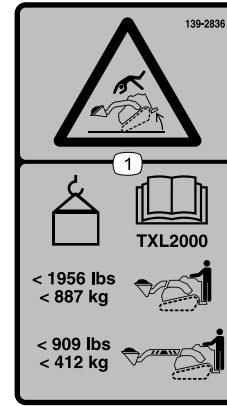

139-2836

decal139-2836

1. Tipping hazard—read the *TXL 2000 Operator's Manual* for load limits; the maximum load with the attachment retracted is 887 kg (1,956 lb); the maximum load with the attachment extended is 412 kg (909 lb).

Decal 139-2837 is for Model 22546.

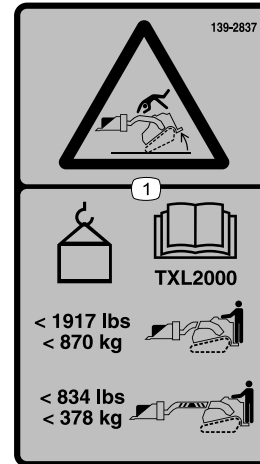

139-2837

decal139-2837

1. Tipping hazard—read the *TXL 2000 Operator's Manual* for load limits; the maximum load with the attachment retracted is 870 kg (1,917 lb); the maximum load with the attachment extended is 378 kg (834 lb).

Decal 139-2838 is for Model 22548.

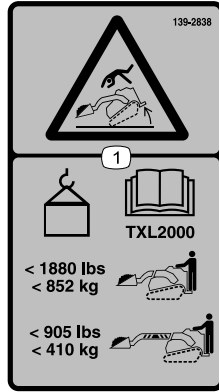

139-2838

decal139-2838

1. Tipping hazard—read the *TXL 2000 Operator's Manual* for load limits; the maximum load with the attachment retracted is 852 kg (1,880 lb); the maximum load with the attachment extended is 410 kg (905 lb).

Product Overview

Specifications

Note: Specifications and design are subject to change without notice.

Model 22546—High Volume Bucket

| | |
|--------------------------------|--|
| Width | 185 cm (73 inches) |
| Length | 124 cm (49 inches) |
| Height | 74 cm (29 inches) |
| Weight | 385 kg (849 lb) |
| Capacity (SAE struck capacity) | 0.8 m ³ (29.0 ft ³) |

Model 22547—Standard Bucket

| | |
|--------------------------------|--|
| Width | 140 cm (55 inches) |
| Length | 107 cm (42 inches) |
| Height | 64 cm (25 inches) |
| Weight | 276 kg (609 lb) |
| Capacity (SAE struck capacity) | 0.4 m ³ (12.8 ft ³) |

Model 22548—Grading Bucket

| | |
|--------------------------------|---|
| Width | 140 cm (55 inches) |
| Length | 99 cm (39 inches) |
| Height | 51 inches |
| Weight | 239 kg (527 lb) |
| Capacity (SAE struck capacity) | 0.3 m ³ (9.3 ft ³) |

Model 22576—Standard Bucket

| | |
|--------------------------------|--|
| Width | 140 cm (55 inches) |
| Length | 107 cm (42 inches) |
| Height | 64 cm (25 inches) |
| Weight | 243 kg (535 lb) |
| Capacity (SAE struck capacity) | 0.4 m ³ (12.8 ft ³) |

To ensure optimum performance and continued safety certification of the machine, use only genuine Toro replacement parts and accessories. Replacement parts and accessories made by other manufacturers could be dangerous, and such use could void the product warranty.

Maximum Material Density at Capacity

The density of the materials moved by the bucket varies and, therefore, so does the amount of material that the bucket can carry before reaching the maximum load rating. The first 2 tables lists the density of material that can be carried, both heaped and struck (i.e., leveled off), in the bucket. The Material Density table lists common materials and their densities.

Model 22546—High-Volume Bucket

| Bucket Capacity | Maximum Density—Loader arms retracted | Maximum Density—Loader arms extended |
|-------------------------|--|---|
| Heaped bucket | 910 kg/m ³ (57 lb/ft ³) | 441 kg/m ³ (28 lb/ft ³) |
| Struck (leveled) bucket | 1105 kg/m ³ (69 lb/ft ³) | 536 kg/m ³ (33 lb/ft ³) |

Model 22547—Standard Bucket

| Bucket Capacity | Maximum Density—Loader arms retracted | Maximum Density—Loader arms extended |
|-------------------------|---|--|
| Heaped bucket | 1922 kg/m ³ (120 lb/ft ³) | 881 kg/m ³ (55 lb/ft ³) |
| Struck (leveled) bucket | 2419 kg/m ³ (151 lb/ft ³) | 1121 kg/m ³ (70 lb/ft ³) |

Model 22548—Grading Bucket

| Bucket Capacity | Maximum Density—Loader arms retracted | Maximum Density—Loader arms extended |
|-------------------------|---|--|
| Heaped bucket | 2280 kg/m ³ (142 lb/ft ³) | 1010 kg/m ³ (63 lb/ft ³) |
| Struck (leveled) bucket | 3186 kg/m ³ (199 lb/ft ³) | 1412 kg/m ³ (88 lb/ft ³) |

Model 22576—Standard Bucket

| Bucket Capacity | Maximum Density—Loader arms retracted | Maximum Density—Loader arms extended |
|-------------------------|---|---|
| Heaped bucket | 1970 kg/m ³ (123 lb/ft ³) | 913 kg/m ³ (57 lb/ft ³) |
| Struck (leveled) bucket | 2499 kg/m ³ (156 lb/ft ³) | 1,153 kg/m ³ (72 lb/ft ³) |

Material Density

| Material | Density (Approximate) |
|----------------------------------|--|
| Caliche | 1250 kg/m ³ (78 lb/ft ³) |
| Clay: | |
| Natural bed | 1600 kg/m ³ (104 lb/ft ³) |
| Dry | 1480 kg/m ³ (93 lb/ft ³) |
| Wet | 1660 kg/m ³ (104 lb/ft ³) |
| With gravel, dry | 1420 kg/m ³ (89 lb/ft ³) |
| With gravel, wet | 1540 kg/m ³ (96 lb/ft ³) |
| Coal: | |
| Anthracite, broken | 1100 kg/m ³ (69 lb/ft ³) |
| Bituminous, broken | 830 kg/m ³ (52 lb/ft ³) |
| Earth: | |
| Dry, packed | 1510 kg/m ³ (94 lb/ft ³) |
| Wet, packed | 1600 kg/m ³ (100 lb/ft ³) |
| Loam | 1250 kg/m ³ (78 lb/ft ³) |
| Granite, broken or large crushed | 1660 kg/m ³ (104 lb/ft ³) |
| Gravel: | |
| Dry | 1510 kg/m ³ (94 lb/ft ³) |
| Pit run (graveled sand) | 1930 kg/m ³ (120 lb/ft ³) |
| Dry, 13 to 51 mm (1/2 to 2 inch) | 1690 kg/m ³ (106 lb/ft ³) |
| Wet, 13 to 51 mm (1/2 to 2 inch) | 2020 kg/m ³ (126 lb/ft ³) |
| Limestone, broken or crushed | 1540 kg/m ³ (96 lb/ft ³) |
| Sand: | |
| Dry | 1420 kg/m ³ (89 lb/ft ³) |
| Wet | 1840 kg/m ³ (115 lb/ft ³) |
| With gravel, dry | 1720 kg/m ³ (107 lb/ft ³) |
| With gravel, wet | 2020 kg/m ³ (126 lb/ft ³) |
| Sandstone, broken | 1510 kg/m ³ (94 lb/ft ³) |
| Shale | 1250 kg/m ³ (78 lb/ft ³) |
| Slag, broken | 1750 kg/m ³ (109 lb/ft ³) |
| Stone, crushed | 1600 kg/m ³ (100 lb/ft ³) |
| Topsoil | 950 kg/m ³ (59 lb/ft ³) |

Operation

Determine the left and right sides of the machine from the normal operating position.

Installing and Removing the Attachment

Refer to the *Operator's Manual* for the traction unit for the installation and removal procedure.

Important: Before installing the attachment, position the machine on a level surface, ensure that the mount plates are free of any dirt or debris, and ensure that the pins rotate freely. If the pins do not rotate freely, grease them.

Note: Always use the traction unit to lift and move the attachment.

⚠ WARNING

If you do not fully seat the quick-attach pins through the attachment mount plate, the attachment could fall off the machine, crushing you or bystanders.

Ensure that the quick-attach pins are fully seated in the attachment mount plate.

Filling the Bucket

1. Position the bucket level to the ground.
2. Drive forward and insert the bucket into the pile of material.
3. When the bucket is full, drive the machine in reverse and gently tilt the bucket rearward to decrease the lifting resistance when you lift the load.

Important: Always carry loads close to the ground with the arms retracted (if applicable); refer to [Transport Position \(page 9\)](#).

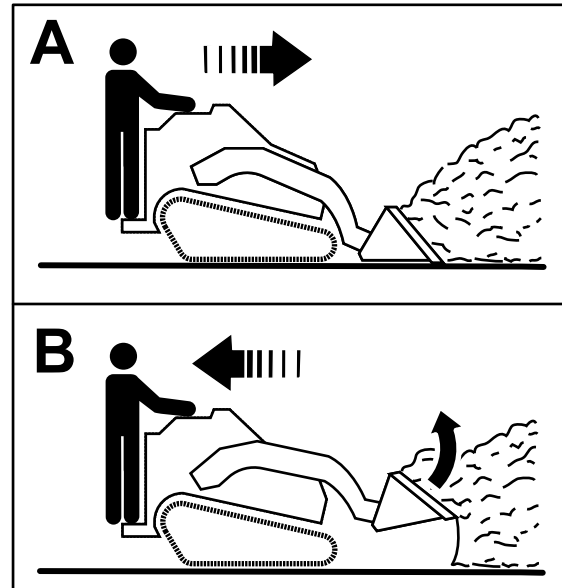

Figure 5

g266856

Transport Position

When transporting a load, keep the attachment as close to the ground as possible, no more than 15 cm (6 inches) above the lowest position. Tilt it rearward to keep the load level.

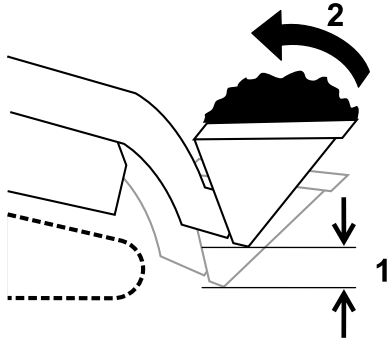

Figure 6

g240205

1. No more than 15 cm (6 inches) above the lowest position
2. Tilt the load rearward

Storage

1. Before long-term storage, wash the attachment with mild detergent and water to remove dirt and grime.
2. Paint all scratched or bare metal surfaces.
Note: Paint is available from your Authorized Service Dealer.
3. Store the attachment in a clean, dry garage or storage area. Cover it to protect it and keep it clean.

Notes:

Notes:

California Proposition 65 Warning Information

What is this warning?

You may see a product for sale that has a warning label like the following:



WARNING: Cancer and Reproductive Harm—www.p65Warnings.ca.gov.

What is Prop 65?

Prop 65 applies to any company operating in California, selling products in California, or manufacturing products that may be sold in or brought into California. It mandates that the Governor of California maintain and publish a list of chemicals known to cause cancer, birth defects, and/or other reproductive harm. The list, which is updated annually, includes hundreds of chemicals found in many everyday items. The purpose of Prop 65 is to inform the public about exposure to these chemicals.

Prop 65 does not ban the sale of products containing these chemicals but instead requires warnings on any product, product packaging, or literature with the product. Moreover, a Prop 65 warning does not mean that a product is in violation of any product safety standards or requirements. In fact, the California government has clarified that a Prop 65 warning "is not the same as a regulatory decision that a product is 'safe' or 'unsafe.'" Many of these chemicals have been used in everyday products for years without documented harm. For more information, go to <https://oag.ca.gov/prop65/faqs-view-all>.

A Prop 65 warning means that a company has either (1) evaluated the exposure and has concluded that it exceeds the "no significant risk level"; or (2) has chosen to provide a warning based on its understanding about the presence of a listed chemical without attempting to evaluate the exposure.

Does this law apply everywhere?

Prop 65 warnings are required under California law only. These warnings are seen throughout California in a wide range of settings, including but not limited to restaurants, grocery stores, hotels, schools, and hospitals, and on a wide variety of products. Additionally, some online and mail order retailers provide Prop 65 warnings on their websites or in catalogs.

How do the California warnings compare to federal limits?

Prop 65 standards are often more stringent than federal and international standards. There are various substances that require a Prop 65 warning at levels that are far lower than federal action limits. For example, the Prop 65 standard for warnings for lead is 0.5 µg/day, which is well below the federal and international standards.

Why don't all similar products carry the warning?

- Products sold in California require Prop 65 labelling while similar products sold elsewhere do not.
- A company involved in a Prop 65 lawsuit reaching a settlement may be required to use Prop 65 warnings for its products, but other companies making similar products may have no such requirement.
- The enforcement of Prop 65 is inconsistent.
- Companies may elect not to provide warnings because they conclude that they are not required to do so under Prop 65; a lack of warnings for a product does not mean that the product is free of listed chemicals at similar levels.

Why does Toro include this warning?

Toro has chosen to provide consumers with as much information as possible so that they can make informed decisions about the products they buy and use. Toro provides warnings in certain cases based on its knowledge of the presence of one or more listed chemicals without evaluating the level of exposure, as not all the listed chemicals provide exposure limit requirements. While the exposure from Toro products may be negligible or well within the "no significant risk" range, out of an abundance of caution, Toro has elected to provide the Prop 65 warnings. Moreover, if Toro does not provide these warnings, it could be sued by the State of California or by private parties seeking to enforce Prop 65 and subject to substantial penalties.