



**Count on it.**

**Operator's Manual**

**8 and 11-Blade 27-inch and  
8-Blade 32-inch EdgeSeries DPA  
Cutting Unit**

**Reelmaster® 7000-D Traction Unit**

Model No. 03721—Serial No. 403447001 and Up

Model No. 03722—Serial No. 403447001 and Up

Model No. 03727—Serial No. 403447001 and Up





# Safety

This machine has been designed in accordance with EN ISO 5395 and ANSI B71.4–2017.

## General Safety

This product is capable of amputating hands and feet. Always follow all safety instructions to avoid serious personal injury.

- Read and understand the contents of this *Operator's Manual* before starting the machine.
- Use your full attention while operating the machine. Do not engage in any activity that causes distractions; otherwise, injury or property damage may occur.
- Do not put your hands or feet near moving components of the machine.
- Do not operate the machine without all guards and other safety protective devices in place and functioning properly on the machine.
- Keep clear of any discharge opening.
- Keep bystanders and children out of the operating area. Never allow children to operate the machine.
- Before you leave the operator's position, do the following:
  - Park the machine on a level surface.
  - Lower the cutting unit(s).
  - Disengage the drives.
  - Engage the parking brake (if equipped).
  - Shut off the engine and remove the key (if equipped).
  - Wait for all movement to stop.

Improperly using or maintaining this machine can result in injury. To reduce the potential for injury, comply with these safety instructions and always pay attention to the safety-alert symbol▲, which means Caution, Warning, or Danger—personal safety instruction. Failure to comply with these instructions may result in personal injury or death.

## Cutting Unit Safety

- The cutting unit is only a complete machine when installed on a traction unit. Read the traction unit *Operator's Manual* carefully for complete instructions on the safe use of the machine.
- Stop the machine, remove the key (if equipped), and wait for all movement to stop before inspecting the attachment after striking an object or if there is an abnormal vibration in the machine. Make all necessary repairs before resuming operation.
- Keep all parts in good working condition and all hardware tightened. Replace all worn or damaged decals.
- Use only accessories, attachments, and replacement parts approved by Toro.

## Blade Safety

A worn or damaged blade can break, and a piece of the blade could be thrown toward you or bystanders, resulting in serious personal injury or death.

- Inspect the blade periodically for wear or damage.
- Use care when checking the blades. Wrap the blades or wear gloves, and use caution when servicing the blades. Only replace or sharpen the blades; never straighten or weld them.
- On multi-bladed machines, take care as rotating 1 blade can cause other blades to rotate.

## Safety and Instructional Decals



Safety decals and instructions are easily visible to the operator and are located near any area of potential danger. Replace any decal that is damaged or missing.



93-6688

decal93-6688

1. Warning—read the instructions before servicing or performing maintenance.
2. Cutting hazard of hand or foot—shut off the engine and wait for moving parts to stop.

# Setup

## Loose Parts

Use the chart below to verify that all parts have been shipped.

Procedure	Description	Qty.	Use
<b>1</b>	Straight grease fitting	1	Install the reel grease fitting.
<b>2</b>	No parts required	–	Adjust the cutting unit
<b>3</b>	O-ring Cap screws (may come assembled)	1 2	Install the reel motors.

## Media and Additional Parts

Description	Qty.	Use
Operator's Manual	1	Review the material and save it in an appropriate place.
Parts Catalog (not included)—refer to the included postcard for information on obtaining the Parts Catalog	–	

**Note:** Determine the left and right sides of the machine from the normal operating position.



## Installing the Reel Grease Fitting

**Parts needed for this procedure:**

1	Straight grease fitting
---	-------------------------

## Procedure

Install the grease fitting on the reel-motor side of the cutting unit. Refer to [Figure 3](#) to determine the position of the reel motors based on the position of the cutting unit on the machine.

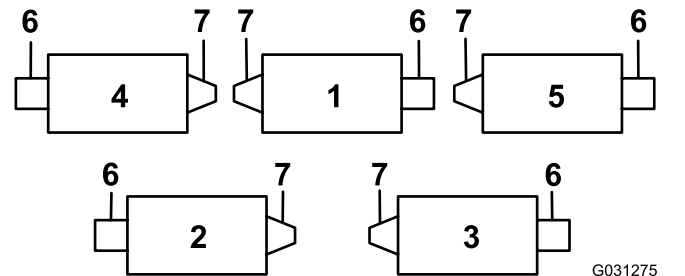

**Figure 3**

1. Cutting unit 1
2. Cutting unit 2
3. Cutting unit 3
4. Cutting unit 4
5. Cutting unit 5
6. Reel motor
7. Weight or other accessory (sold separately)

1. Remove and discard the setscrew on the reel-motor side plate ([Figure 4](#)).

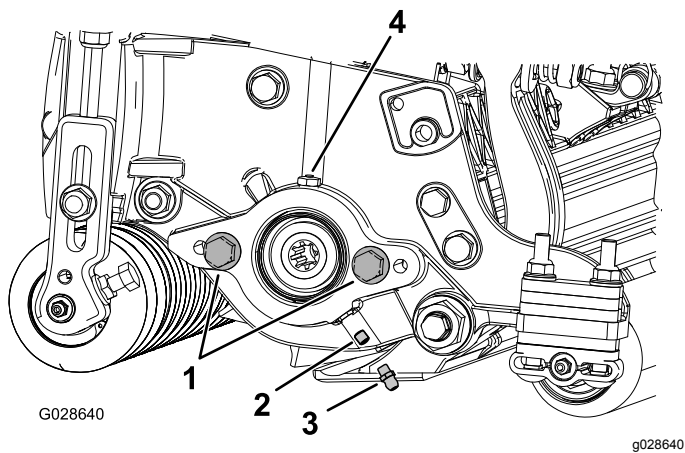

Figure 4

1. Cap screw (2)
2. Setscrew
3. Grease fitting
4. Grease vent

2. Install the straight grease fitting (Figure 4).

## 2

### Adjusting the Cutting Unit

No Parts Required

#### Procedure

1. Adjust the bedknife to the reel.
2. Adjust the rear roller for your height-of-cut requirements.
3. Set the height of cut.
4. Adjust the rear shield if necessary.
5. Adjust the cutting unit steering as required.
6. Once all of the cutting units are installed on the traction unit and operational, adjust the turf compensation springs.

Refer to [Adjusting the Cutting Unit \(page 6\)](#) for complete instructions for performing these adjustments

## 3

### Installing the Reel Motors

Parts needed for this procedure:

1	O-ring
2	Cap screws (may come assembled)

#### Procedure

**Important:** Before installing the reel motors, obtain and install the counter weights or other accessories on the opposite side of the cutting units from the reel motors as described in the instructions provided with the weights or accessories.

1. Install the cutting units onto the traction unit; refer to the traction unit *Operator's Manuals* for instructions.
2. If there are no cap screws on the reel-motor side plate, install them (Figure 4).
3. Install the O-ring on the reel motor (Figure 5).

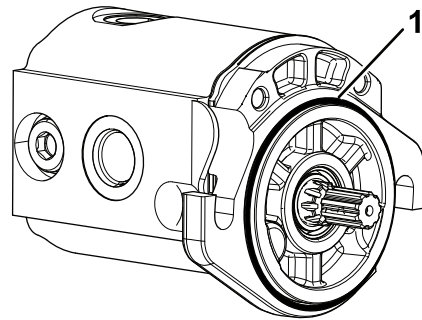

Figure 5

1. O-ring
4. Install the reel motor and secure it with the cap screws.
5. Grease the side plate until excess grease comes out of the grease vent (Figure 4).

# Product Overview

## Specifications

Model Number	Weight
03721	66 kg (145 lb)
03722	68 kg (150 lb)
03727	74 kg (162 lb)

## Attachments/Accessories

A selection of Toro approved attachments and accessories is available for use with the machine to enhance and expand its capabilities. Contact your Authorized Service Dealer or authorized Toro distributor or go to [www.Toro.com](http://www.Toro.com) for a list of all approved attachments and accessories.

To ensure optimum performance and continued safety certification of the machine, use only genuine Toro replacement parts and accessories. Replacement parts and accessories made by other manufacturers could be dangerous, and such use could void the product warranty.

# Operation

**Note:** Determine the left and right sides of the machine from the normal operating position.

## Adjusting the Cutting Unit

### Adjusting the Rear Shield

Under most conditions, you can attain the best clipping dispersion when the rear shield is closed (front discharge). When conditions are heavy or wet, you may open the rear shield.

To open the rear shield (Figure 6), loosen the bolt securing the shield to the left side plate, rotate the shield to the open position, and tighten the bolt.

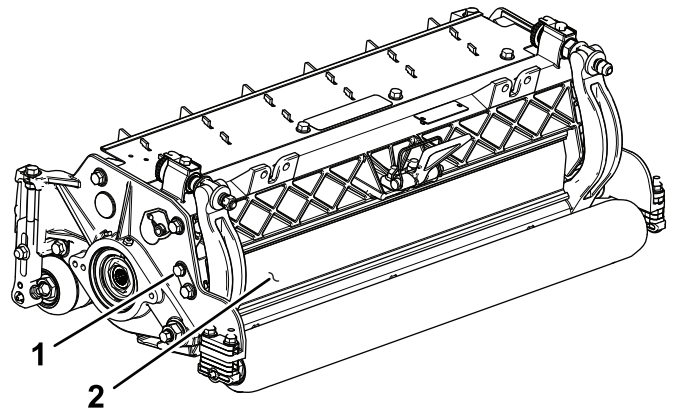

Figure 6

g191341

1. Bolt
2. Rear shield

## Checking the Cutting Unit

The dual knob bedknife-to-reel adjustment system incorporated in this cutting unit simplifies the adjustment procedure needed to deliver optimum mowing performance. The precise adjustment possible with the dual knob/bedbar design gives the necessary control to provide a continual self-sharpening action—thus maintaining sharp cutting edges, ensuring good quality of cut, and greatly reducing the need for routine backlapping.

Prior to mowing each day, or as required, check each cutting unit to verify proper bedknife-to-reel contact.

**Perform this procedure even if the quality of cut is acceptable.**

1. Slowly rotate the reel in a reverse direction, listening for reel-to-bedknife contact.

**Note:** The adjustment knobs have detents corresponding to 0.018 mm (0.0007 inch) bedknife movement for each indexed position.

Refer to [Adjusting the Bedknife to the Reel](#) (page 8).

2. Test the cutting performance by inserting a long strip of cutting performance paper (Toro Part 125-5610) between the reel and the bedknife, perpendicular to the bedknife (Figure 7). Slowly rotate the reel forward; it should cut the paper.

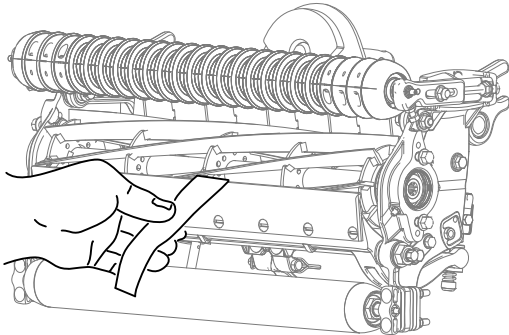

Figure 7

g027166  
g027166

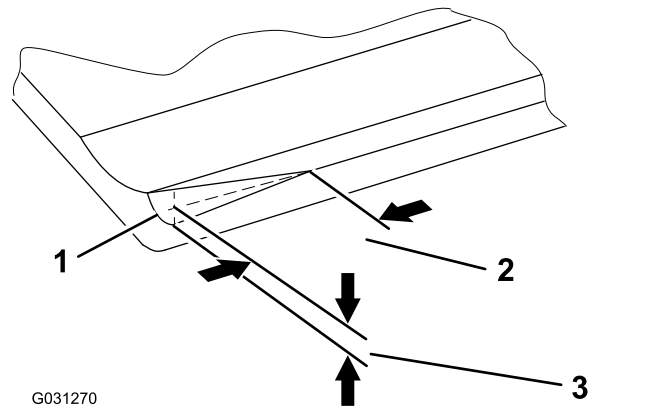

Figure 8

1. Lead-in chamfer on right end of bedknife
2. 6 mm (0.25 inch)
3. 1.5 mm (0.060 inch)

**Note:** Do not make the lead-in chamfer too large as it may cause turf tufting.

**Note:** If excessive contact/reel drag is evident, either backlap, reface the front of the bedknife, or grind the cutting unit to achieve the sharp edges needed for precision cutting; refer to the *Toro Manual for Sharpening Reel and Rotary Mowers*, Form No. 09168SL.

**Important:** Light contact is preferred at all times. If you do not maintain light contact, the bedknife and reel edges will not sufficiently self-sharpen and will dull after a period of operation. If you maintain excessive contact, the bedknife and reel will wear quicker, wear unevenly, and the quality of cut may be adversely affected.

**Note:** After extended running, a ridge will eventually develop at both ends of the bedknife. Round off or file these notches flush with the cutting edge of the bedknife to ensure smooth operation.

**Note:** Over time, you will need to grind the chamfer (Figure 8), as it is only designed to last 40% of the bedknife life.

## Adjusting the Cutting-Unit Steering

### Increasing the Steering for the Rear Cutting Units

Increase the steering on the rear cutting units by removing the 2 pivot spacers, hex socket screws, and flange locknuts (Figure 9) from the carrier frames of the rear cutting units (cutting units 2 and 3); refer to Figure 10.

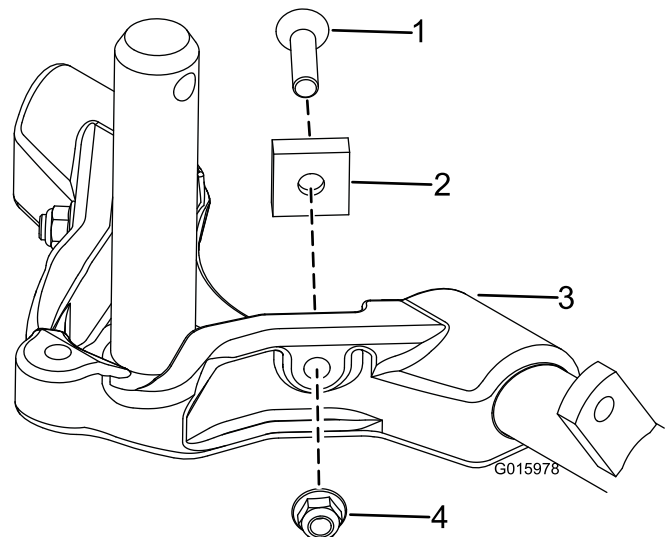
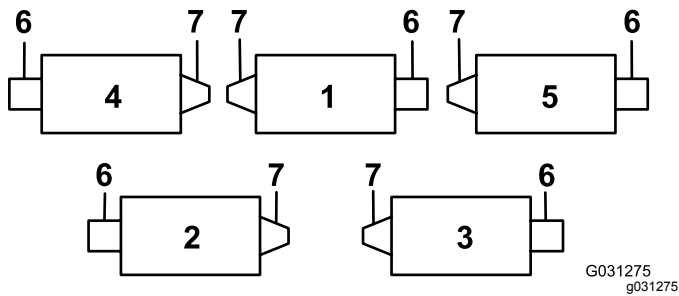

Figure 9

1. Hex socket screw
2. Pivot spacer
3. Carrier frame
4. Flange locknut

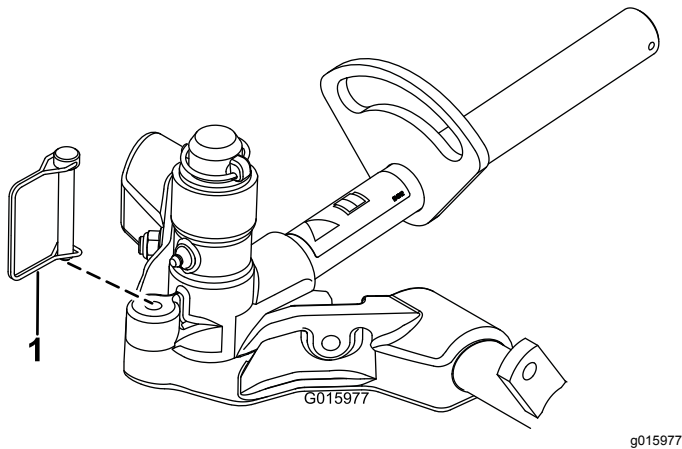

**Figure 10**

- |                   |                   |
|-------------------|-------------------|
| 1. Cutting unit 1 | 5. Cutting unit 5 |
| 2. Cutting unit 2 | 6. Reel motor     |
| 3. Cutting unit 3 | 7. Weight         |
| 4. Cutting unit 4 |                   |

## Locking the Steering

To lock (fix) the steering on the cutting units, secure the pivot yoke to the carrier frame with the snapper pin (Figure 11).



**Figure 11**

1. Snapper pin

**Note:** Fixed steering is recommended when cutting side hills.

## Adjusting the Bedknife to the Reel

Use this procedure to set the bedknife to the reel and to check the condition of the reel and bedknife and their interaction. After completing this procedure, always test the cutting unit performance under your field conditions. You may need to make further adjustments to obtain optimal cutting performance.

**Important:** Do not overtighten the bedknife to the reel or you will damage it.

- After backlapping the cutting unit or grinding the reel, you may need to mow with the cutting unit for a few minutes and then perform this procedure

to adjust the bedknife to the reel as the reel and bedknife adjust to each other.

- You may need additional adjustments if the turf is extremely dense or your cutting height is very low.

You will need the following tools to complete this procedure:

- Shim 0.05 mm (0.002 inch) (Part No. 125-5611)
- Cutting performance paper (Part No. 125-5610)

- Position the cutting unit on a flat, level work surface.
- Turn the bedbar-adjusting screws counterclockwise to ensure that the bedbar does not contact the reel (Figure 12).

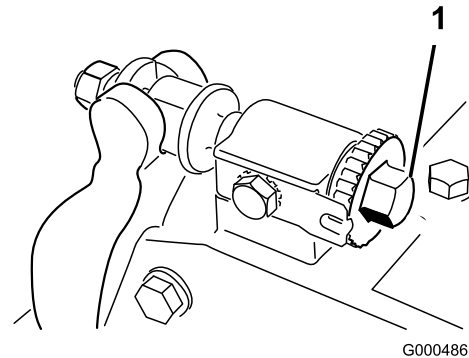

**Figure 12**

1. Bedbar-adjusting screw

3. Tip the cutting unit to expose the bedknife and reel.

**Important:** Make sure that the nuts on the back end of the bedbar-adjusting screws are not resting on the work surface; use the kickstand (Figure 13).



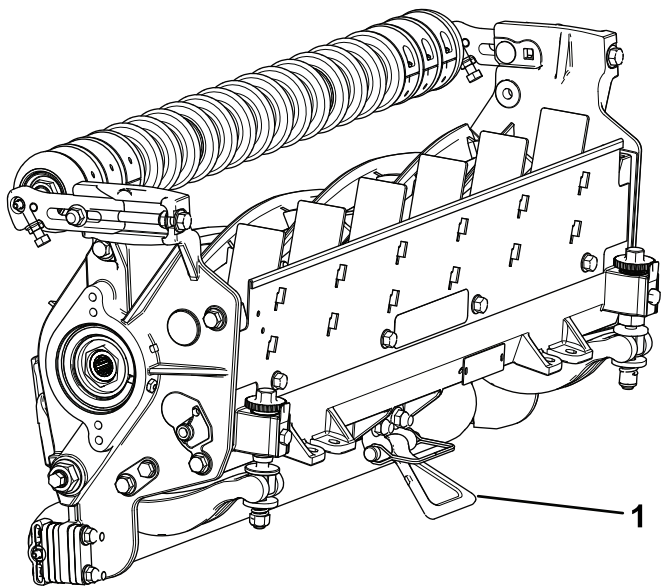

Figure 13

g191340

1. Kickstand

4. Rotate the reel so that a blade crosses the bedknife approximately 25 mm (1 inch) in from the end of the bedknife on the right side of the cutting unit.

**Note:** Put an identifying mark on this blade to make subsequent adjustments easier.

5. Insert the 0.05 mm (0.002 inch) shim between the marked reel blade and the bedknife at the point where the blade crosses the bedknife.
6. Turn the right bedbar adjuster clockwise until you feel **light** pressure (i.e. drag) on the shim, then back off the bedbar adjuster 2 clicks and remove the shim.

**Note:** Adjusting 1 side of the cutting unit affects the other side, the 2 clicks will provide clearance for when the other side is adjusted.

**Note:** If starting with a large gap, both sides should initially be drawn closer by alternately tightening the right and left sides.

7. **Slowly** rotate the reel so that the same blade that you checked on the right side is crossing the bedknife approximately 25 mm (1 inch) in from the end of the bedknife on the left side of the cutting unit.
8. Turn the left bedbar adjuster clockwise until the shim can be slid through the reel to bedknife gap with light drag.
9. Return to the right side and adjust as necessary to get light drag on the shim between the same blade and bedknife.
10. Repeat steps 8 and 9 until the shim can be slid through both gaps with slight drag, but 1 click in

on both sides prevents the shim from passing through on both sides.

**Note:** The bedknife is now parallel to the reel.

**Note:** This procedure should not be needed on daily adjustments, but should be done after grinding or disassembly.

11. From this position (i.e., 1 click in and shim not passing through) turn the bedbar adjusters clockwise 1 click each.

**Note:** Each click turned moves the bedknife 0.022 mm (0.0009 inch). **Do not overtighten the adjusting screws.**

12. Test the cutting performance by inserting a long strip of Toro cutting performance paper between the reel and the bedknife, perpendicular to the bedknife (Figure 14).

**Note:** **Slowly** rotate the reel forward; it should cut the paper.

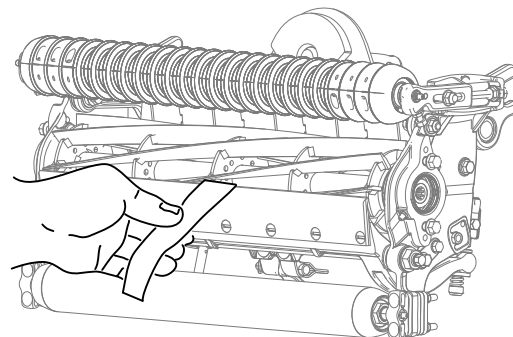

Figure 14

g027166

g027166

**Note:** If excessive reel drag occurs, either backlap or grind the cutting unit to achieve the sharp edges needed for precision cutting.

## Adjusting the Rear Roller

1. Adjust the rear roller brackets (Figure 15) to the desired height-of-cut range by positioning the required amount of spacers below the side-plate mounting flange (Figure 15) per the HOC Chart.

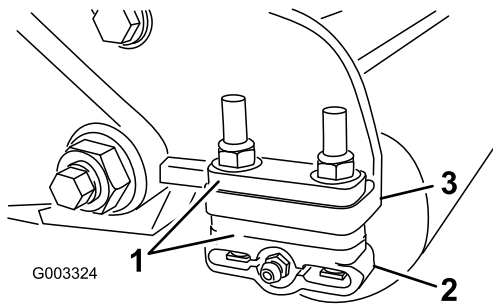
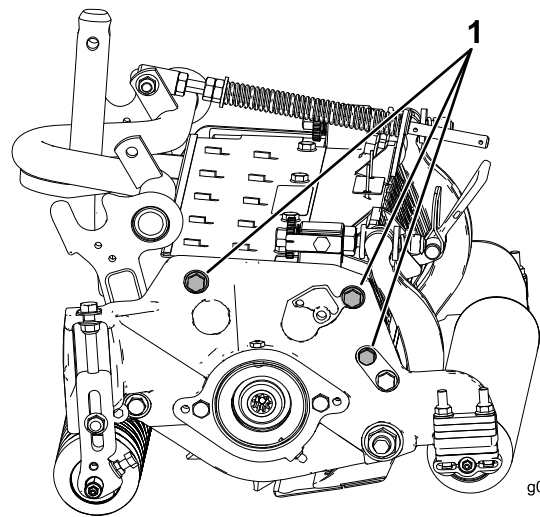

**Figure 15**

1. Spacer
2. Roller bracket
3. Side-plate mounting flange

2. Raise the rear of the cutting unit and place a block under the bedknife.
3. Remove the 2 nuts securing each roller bracket and spacer to each side-plate mounting flange.
4. Lower the roller and screws from the side-plate mounting flanges and spacers.
5. Place the spacers onto the screws on the roller brackets.
6. Secure the roller bracket and spacers to underside of side plate mounting flanges with the nuts previously removed.
7. Verify that the bedknife-to-reel contact is correct. Tip the mower to expose the front and rear rollers and bedknife.

**Note:** The position of the rear roller to the reel is controlled by the machining tolerances of the assembled components; therefore, paralleling is not required. A limited amount of adjustment is possible by setting the cutting unit on a surface plate and loosening the side-plate mounting cap screws (Figure 16). Adjust and tighten the cap screws. Torque the cap screws to 37 to 45 N-m (27 to 33 ft-lb).



**Figure 16**

1. Side-plate mounting cap screws

## Adjusting the Turf-Compensation Settings

The turf-compensation spring transfers the weight from the front to the rear roller. This helps to reduce a wave pattern in the turf, also known as marcelling or bobbing.

**Important:** Make the spring adjustments with the cutting unit mounted to the traction unit, pointing straight ahead and lowered to the shop floor.

1. Make sure that the hairpin cotter is installed in the rear hole in the spring rod (Figure 17).

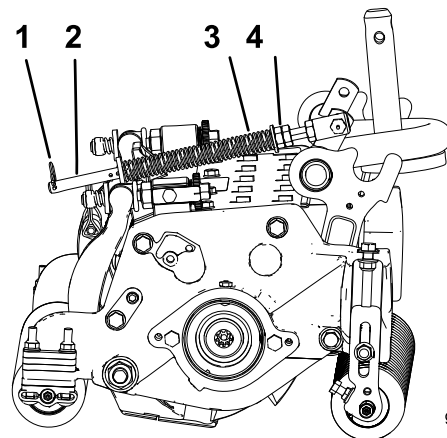

**Figure 17**

1. Turf-compensation spring
2. Hairpin cotter
3. Spring rod
4. Hex nuts

2. Tighten the hex nuts on the front end of the spring rod until the compressed length of the spring is 15.9 cm (6.25 inches) (Figure 17).

**Note:** When operating the machine on rough terrain, decrease the spring length by 12.7 mm (1/2 inch).

**Note:** The turf-compensation setting will need to be reset if the HOC setting or the aggressiveness-of-cut setting is changed.

## Adjusting the Height of Cut (HOC)

**Note:** For heights of cut greater than 2.54 cm (1 inch) install the High Height-of-Cut Kit.

1. Loosen the locknuts securing the height-of-cut brackets to the cutting-unit side plates (Figure 18).

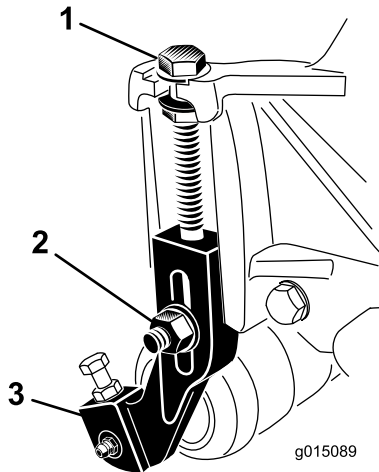

Figure 18

1. Adjusting screw
2. Locknut
3. Height-of-cut bracket

2. Loosen the nut on the gauge bar (Figure 19) and set the adjusting screw to the desired height of cut. The distance between the bottom of the screw head and the face of the bar is the height of cut.

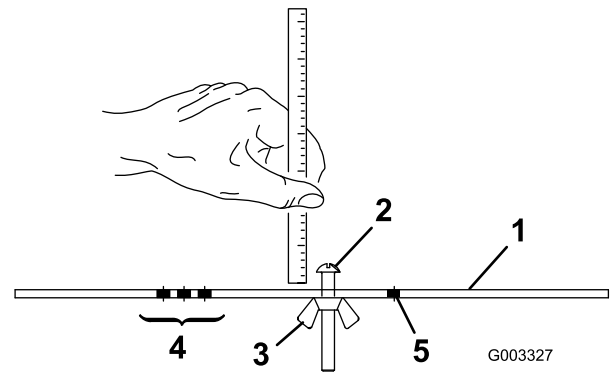

Figure 19

1. Gauge bar
2. Height-adjusting screw
3. Nut
4. Holes used for setting the height of groom (HOG)
5. Hole not used

3. Hook the screw head on the cutting edge of the bedknife and rest the rear end of the bar on the rear roller (Figure 20).
4. Rotate the adjusting screw until the front roller contacts the gauge bar (Figure 20). Adjust both ends of roller until the entire roller is parallel to the bedknife.

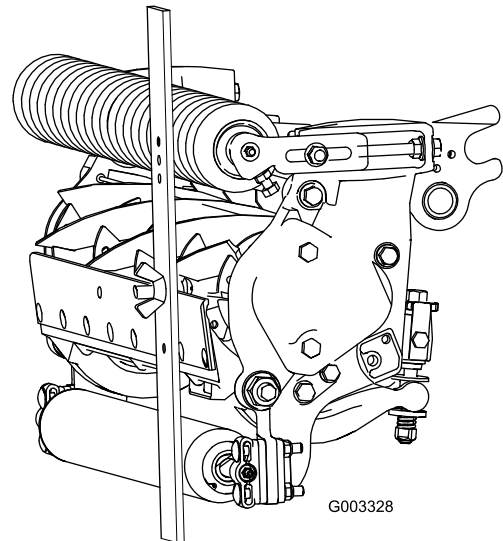

Figure 20

**Important:** When set properly, the rear and front rollers will contact the gauge bar and the screw will be snug against the bedknife. This ensures that the height of cut is identical at both ends of the bedknife.

5. Tighten the nuts to secure the adjustment.

**Note:** Do not overtighten the nuts. Tighten them just enough to remove play from the washer.

## Height-of-Cut Chart

HOC Setting	Aggressiveness of Cut	No. of Rear Spacers	No. of Chain Links	With Groomer kits installed**
0.64 cm (0.250 inch)	Less	0	5+	Y
	Normal	0	5+	Y
	More	1	5+	-
0.95 cm (0.375 inch)	Less	0	5+	Y
	Normal	1	5+	Y
	More	2	5+	-
1.27 cm (0.500 inch)	Less	0	6	Y
	Normal	1	5+	Y
	More	2	5+	Y
1.56 cm (0.625 inch)	Less	1	6	Y
	Normal	2	5+	Y
	More	3	5+	-
1.91 cm (0.750 inch)	Less	2	6	Y
	Normal	3	5+	Y
	More	4	6	-
2.22 cm (0.875 inch)	Less	2	6	Y
	Normal	3	6	Y
	More	4	5+	-
2.54 cm (1.000 inch)	Less	3	6	Y
	Normal	4	5+	Y
	More	5	5+	-
2.86 cm (1.125 inches)*	Less	4	6	-
	Normal	5	5	-
	More	6	5	-
3.18 cm (1.250 inches)*	Less	4	6	-
	Normal	5	6	-
	More	6	6	-
3.49 cm (1.375 inches)*	Less	4	6	-
	Normal	5	6	-
	More	6	6	-
3.81 cm (1.500 inches)*	Less	5	6	-
	Normal	6	6	-
	More	7	6	-

HOC Setting	Aggressiveness of Cut	No. of Rear Spacers	No. of Chain Links	With Groomer kits installed**
4.13 cm (1.625 inches)	Less	5	5	-
	Normal	6	5	-
	More	7	5	-
4.44 cm (1.750 inches)	Less	6	5	-
	Normal	7	5	-
	More	8	6	-
4.76 cm (1.875 inches)	Less	7	5	-
	Normal	8	6	-
	More	9	6	-
5.08 cm (2.000 inches)	Less	7	6	-
	Normal	8	6	-
	More	9	6	-
5.40 cm (2.125 inches)	Less	8	6	-
	Normal	9	6	-
	More	10	6	-
5.71 cm (2.250 inches)	Less	8	6	-
	Normal	9	6	-
	More	10	6	-
6.03 cm (2.375 inches)	Less	9	6	-
	Normal	10	6	-
	More	11	6	-
6.35 cm (2.500 inches)	Less	9	6	-
	Normal	10	6	-
	More	11	6	-

+ indicates that the U bracket, on the lift arm, is positioned in the bottom hole (Figure 23).

"Y" indicates that this combination of HOC and spacers can be used with 27-inch groomers.

**Note:** Changing 1 chain link changes the pitch-angle movement of the rear roller by 7.0 degrees.

**Note:** Changing the U-bracket on the lift arm to the bottom hole adds 3.5 degrees to the pitch angle of the rear roller.

Use the following chart to determine which bedknife is best suited for the desired height of cut.

Bedknife/Height of Cut Chart			
Bedknife	Part No.	Bedknife Lip Height	Height of Cut
Low HOC (Optional)	120-1641 (27 inch) 120-1642 (32 inch)	5.6 mm (0.220 inch)	6.4 to 12.7 mm (0.250 to 0.500 inch)
EdgeMax® (Optional)	112-8910 (27 inch) 112-8956 (32 inch)	6.9 mm (0.270 inch)	9.5 to 63.5 mm (0.375 to 2.50 inches)*
Standard (Production)	114-9388 (27 inch) 114-9389 (32 inch)	6.9 mm (0.270 inch)	9.5 to 63.5 mm (0.375 to 2.50 inches)*
Heavy Duty (Optional)	114-9390 (27 inch) 114-9391 (32 inch)	9.3 mm (0.370 inch)	12.7 to 63.5 mm (0.500 to 2.50 inches)

\* Warm-season grasses may require the Low HOC bedknife for 12.7 mm (0.500 inch) and below.

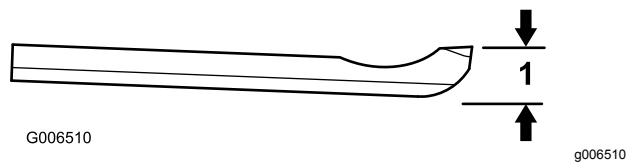

Figure 21

1. Bedknife lip height

of cut refers to the angle of the bedknife relative to the ground (Figure 22).

The best cutting-unit setup depends on your turf conditions and desired results. Experience with the cutting unit on your turf will determine the best setting to use. You can adjust the aggressiveness of cut throughout the cutting season to allow for various turf conditions.

In general, less to normal aggressive settings are more appropriate for warm-season grasses (Bermuda, paspalum, zoysia) while cool-season grasses (bent, bluegrass, rye) may require normal to more aggressive setups. More aggressive setups cut more grass off by allowing the spinning reel to pull more grass up into the bedknife.

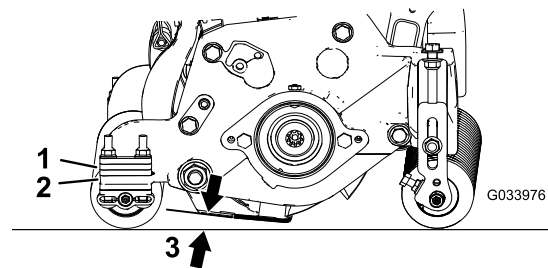

Figure 22

1. Rear spacers
2. Side-plate mounting flange
3. Aggressiveness of cut

## Height-of-Cut Chart Terms

### Height-of-Cut Setting (HOC)

This corresponds to the desired height of cut.

### Bench-Set Height of Cut

The bench-set height of cut is the height at which the top edge of the bedknife is set above a flat level surface that contacts the bottom of both the front roller and the rear roller.

### Effective Height of Cut

This is the actual height that the grass has been cut. For a given bench-set height of cut, the actual height of cut will vary depending on the type of grass, time of year, turf, and soil conditions. The cutting-unit setup (aggressiveness of cut, rollers, bedknives, attachments installed, turf-compensation settings, etc.) will also affect the effective height of cut. Check the effective height of cut using the Turf Evaluator (Model 04399) regularly to determine the desired bench-set height of cut.

### Aggressiveness of Cut

The aggressiveness of cut has a significant impact on the performance of the cutting unit. Aggressiveness

### Rear Spacers

The number of rear spacers determines the aggressiveness of cut for the cutting unit. For a given height of cut, adding spacers below the side-plate mounting flange increases the aggressiveness of the cutting unit. All cutting units on a given machine must be set to the same aggressiveness of cut (number of rear spacers, Toro Part No. 106-3925); otherwise,

the after-cut appearance could be negatively affected (Figure 22).

## Chain Links

The location at which the lift-arm chain is attached determines the pitch angle of the rear roller (Figure 23).

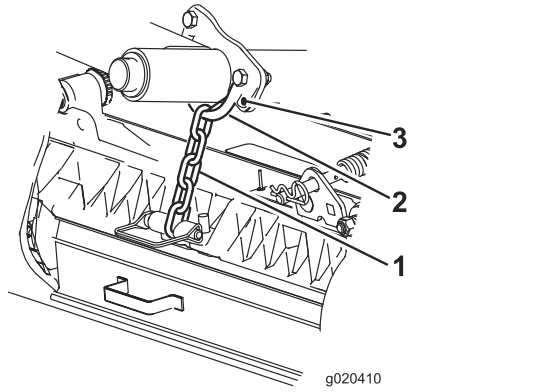

**Figure 23**

- 1. Lift chain
- 2. U bracket
- 3. Bottom hole

---

## Groomer

These are the recommended height-of-cut settings when a groomer kit is installed on the cutting unit.

# Maintenance

## Using the Kickstand When Tipping the Cutting Unit

Whenever the cutting unit has to be tipped to expose the bedknife/reel, prop up the rear of the cutting unit with the kickstand (supplied with the traction unit) to make sure that the nuts on the back end of the bedbar adjusting screws are not resting on the work surface (Figure 24).

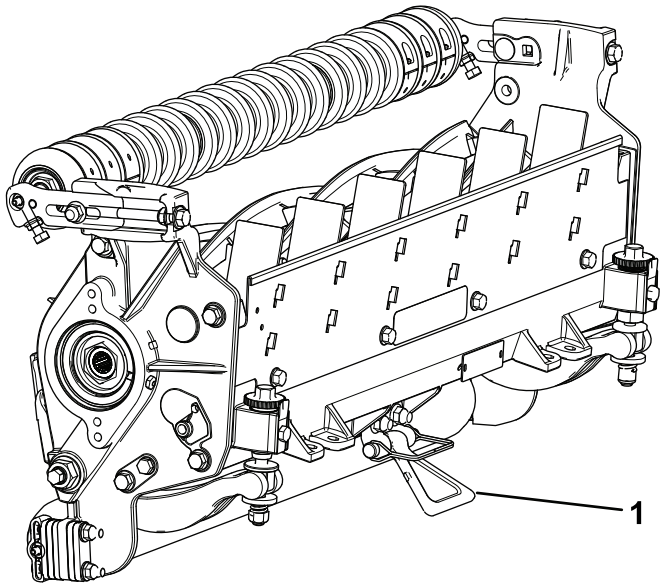

Figure 24

g191340

1. Kickstand

## Lubricating the Cutting Unit

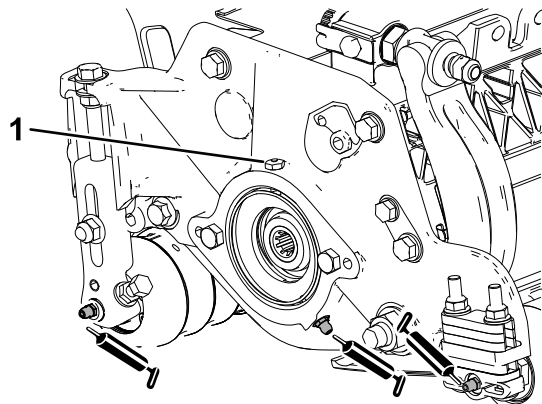

Figure 25

g191601

1. Relief valve

Each cutting unit has 5 grease fittings (Figure 25) that must be lubricated regularly with No. 2 lithium grease.

The lubrication points are the front roller (2), the rear roller (2), and at the reel motor spline (1).

**Note:** Lubricating the cutting units immediately after washing helps purge water out of the bearings and increases bearing life.

1. Wipe each grease fitting with a clean rag.
2. Apply grease until clean grease comes out of the roller seals and the bearing relief valve.
3. Wipe any excess grease away.

## Relief-Grinding the Reel

The new reel has a land width of 1.3 to 1.5 mm (0.050 to 0.060 inch) and a 30 degree relief grind.

When the land width gets larger than 3 mm (0.120 inch) wide, do the following:

1. Apply a 30 degree relief grind on all reel blades until the land width is 1.3 mm (0.050 inch) wide (Figure 26).

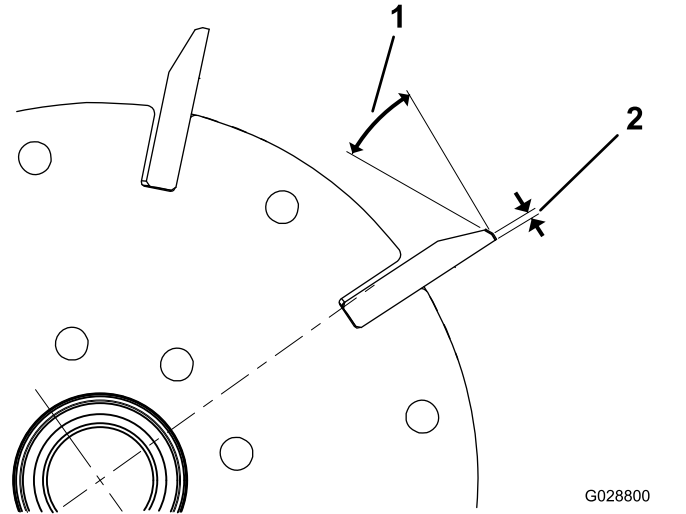

Figure 26

G028800

g028800

1. 30 degrees
2. 1.3 mm (0.050 inch)

2. Spin grind the reel to achieve  $<0.025$  mm (0.001 inch) reel run-out.

**Note:** This causes the land width to grow slightly.

**Note:** To extend the longevity of the sharpness of the edge of the reel and the bedknife—after grinding the reel and/or the bedknife—check the reel to bedknife contact again after cutting 2 fairways, as any burrs will be removed, which may create improper reel to bedknife clearance and thus accelerate wear.

# Servicing the Bedknife

The bedknife service limits are listed in the following chart.

**Important:** Operating the cutting unit with the bedknife below the service limit may result in poor after-cut appearance and reduce the structural integrity of the bedknife for impacts.

Bedknife Service Limit Chart				
Bedknife	Part No.	Bedknife Lip Height	Service Limit*	Grind Angles Top/Front Angles
Low HOC (Optional)	120-1641 (27 inch) 120-1642 (32 inch)	5.6 mm (0.220 inch)	4.8 mm (0.190 inch)	10/5 degrees
EdgeMax® (Optional)	112-8910 (27 inch) 112-8956 (32 inch)	6.9 mm (0.270 inch)	4.8 mm (0.190 inch)	10/5 degrees
Standard (Production)	114-9388 (27 inch) 114-9389 (32 inch)	6.9 mm (0.270 inch)	4.8 mm (0.190 inch)	10/5 degrees
Heavy Duty (Optional)	114-9390 (27 inch) 114-9391 (32 inch)	9.3 mm (0.370 inch)	4.8 mm (0.190 inch)	10/5 degrees

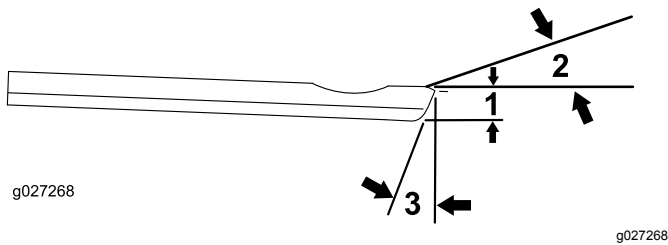
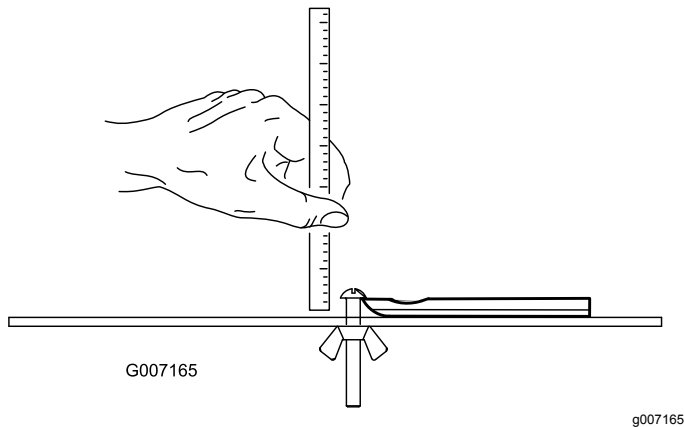

**Figure 27**

Recommended Top and Front Bedknife Grind Angles

1. Bedknife service limit\*
2. Top grind angle
3. Front grind angle

**Note:** All bedknife service limit measurements relate to the bottom of the bedknife (Figure 28).



**Figure 28**

## Checking the Top Grind Angle

The angle that you use to grind your bedknives is very important.

Use the angle indicator (Toro Part No. 131-6828) and the angle-indicator mount (Toro Part No. 131-6829) to check the angle that your grinder produces and then correct for any grinder inaccuracy.

1. Place the angle indicator on the bottom side of the bedknife as shown in Figure 29.

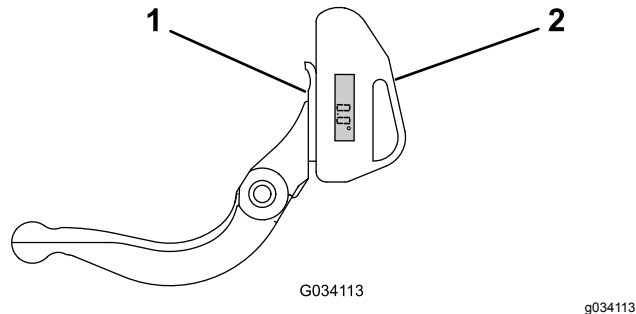

**Figure 29**

1. Bedknife (vertical)
2. Angle indicator

2. Press the Alt Zero button on the angle indicator.
3. Place the angle-indicator mount on the edge of the bedknife so that the edge of the magnet is mated with the edge of the bedknife (Figure 30).

**Note:** The digital display should be visible from the same side during this step as it was in step 1.



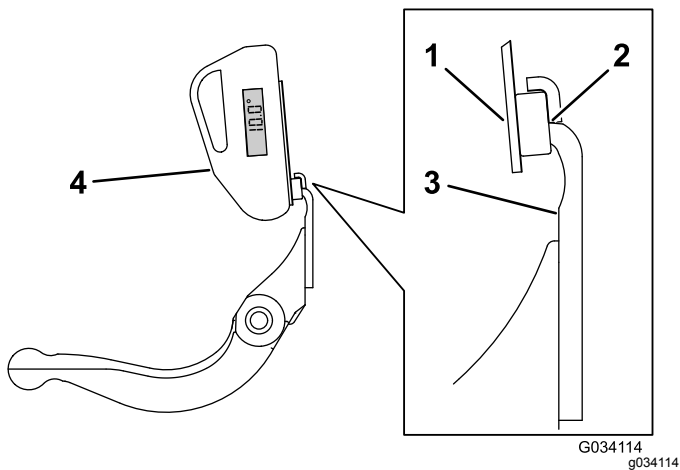

**Figure 30**

- |   |                    |
|---|--------------------|
| 1. Angle-indicator mount                                  | 3. Bedknife        |
| 2. Edge of the magnet mated with the edge of the bedknife | 4. Angle indicator |

- Place the angle indicator on the mount as shown in [Figure 30](#).

**Note:** This is the angle that your grinder produces; it should be within 2 degrees of the recommended top grind angle.

## Servicing the Bedbar

### Removing the Bedbar

- Turn the bedbar-adjuster screws counterclockwise to back the bedknife away from the reel ([Figure 31](#)).

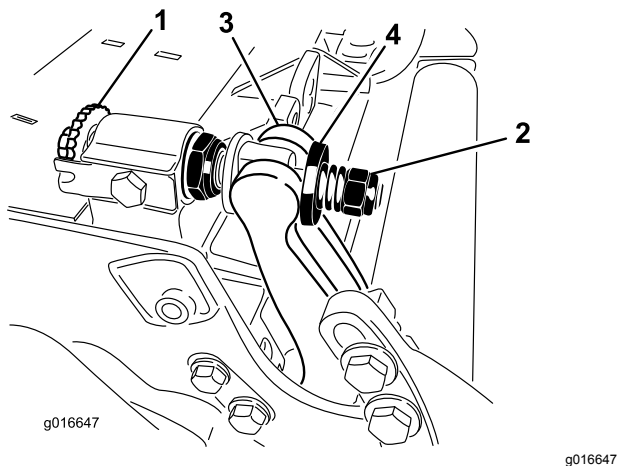
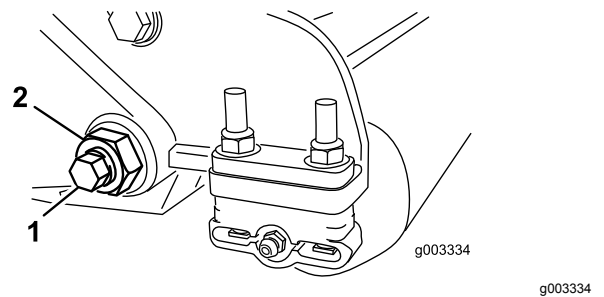

**Figure 31**

- |                           |           |
|---------------------------|-----------|
| 1. Bedbar-adjusting screw | 3. Bedbar |
| 2. Spring-tension nut     | 4. Washer |

- Back out the spring-tension nut until the washer is no longer tensioned against the bedbar ([Figure 31](#)).

- On each side of the machine, loosen the locknut securing the bedbar bolt ([Figure 32](#)).

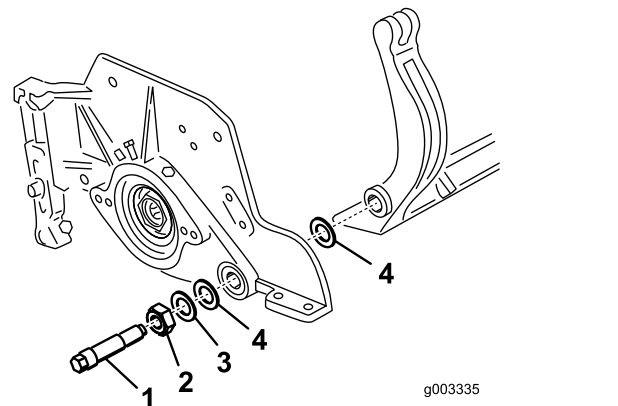

**Figure 32**

- |                |             |
|----------------|-------------|
| 1. Bedbar bolt | 2. Lock nut |
|----------------|-------------|

- Remove each bedbar bolt, allowing the bedbar to be pulled downward and removed from machine bolt ([Figure 32](#)).

**Note:** Account for 2 nylon washers and 1 stamped steel washer on each end of the bedbar ([Figure 33](#)).



**Figure 33**

- |                |                 |
|----------------|-----------------|
| 1. Bedbar bolt | 3. Steel washer |
| 2. Nut         | 4. Nylon washer |

### Assembling the Bedbar

- Install the bedbar, positioning the mounting ears between the washer and the bedbar adjuster.
- Secure the bedbar to each side plate with the bedbar bolts (nuts on bolts) and 6 washers.

**Note:** Position a nylon washer on each side of the side-plate boss. Place a steel washer outside each of the nylon washers ([Figure 33](#)).

- Torque the bedbar bolts to 37 to 45 N·m (27 to 33 ft·lb).

**Note:** Tighten the locknuts until the outside steel washer stops rotating and end play is removed, but do not overtighten or deflect the side plates. The washers on the inside may have a gap.

- Tighten the spring-tension nut until the spring is collapsed, then back off 1/2 turn (Figure 34).

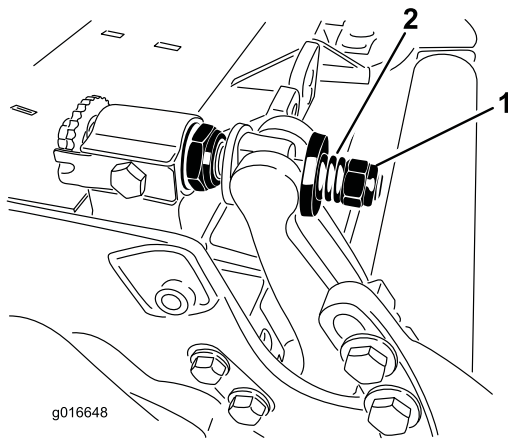
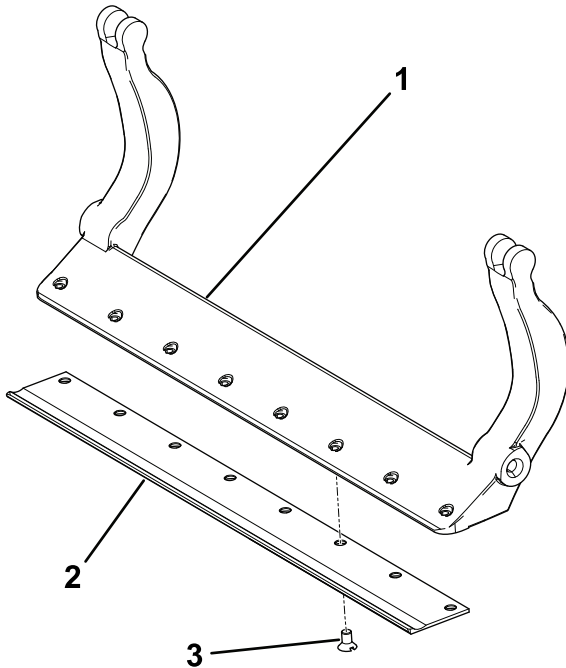

**Figure 34**

- Spring-tension nut
- Spring

## Installing the Bedknife

- Remove the rust, scale, and corrosion from the bedbar surface and apply a thin layer of oil to the bedbar surface.
- Clean the screw threads.
- Apply anti-seize compound to the screws and install the bedknife to the bedbar as follows (Figure 35):



**Figure 35**

- Bedbar
- Bedknife
- Screw

- Torque the 2 outer screws to 1 N·m (10 in-lb); refer to Figure 35.
- Working from the center of the bedknife, torque the screws to 23 to 28 N·m (200 to 250 in-lb); refer to Figure 35.

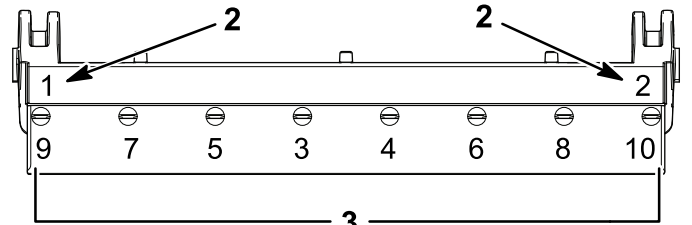
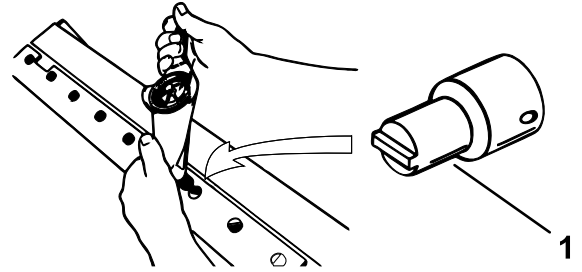

**Figure 36**

- Bedknife screw tool
- Install and torque these first to 1 N·m (10 in-lb).
- Torque to 23 to 28 N·m (200 to 250 in-lb).
- Grind the bedknife.

# Servicing the HD Dual Point Adjusters (DPA)

1. Remove all parts (refer to the *Installation Instructions* for the HD DPA Kit (Model No. 120-7230) and to [Figure 37](#)).
2. Apply anti-seize compound to the inside of the bushing area on the carrier frame of the cutting unit ([Figure 37](#)).

3. Align the keys on flange bushings to the slots in the frame and install the bushings ([Figure 37](#)).
4. Install a wave washer onto the adjuster shaft and slide the adjuster shaft into the flange bushings in the frame of the cutting unit ([Figure 37](#)).
5. Secure the adjuster shaft with a flat washer and locknut ([Figure 37](#)). Torque the locknut to 20 to 27 N·m (15 to 20 ft-lb).

**Note:** The bedbar adjuster shaft has left-hand threads.

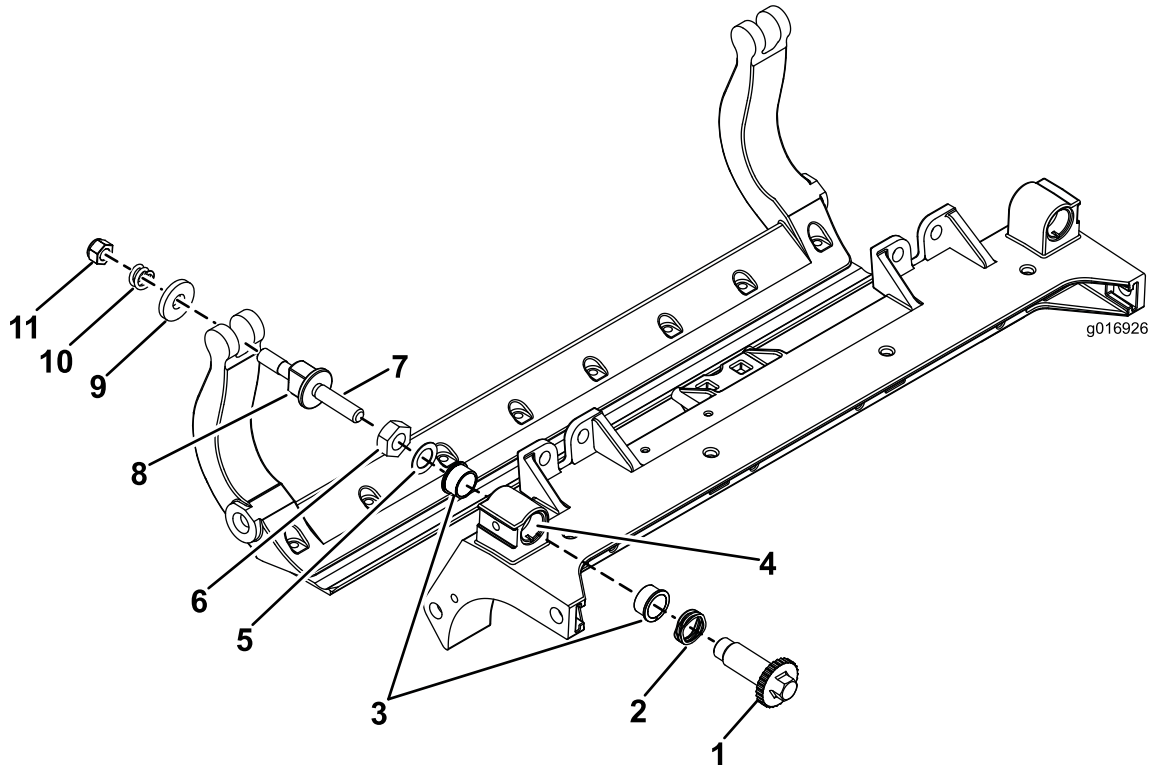

**Figure 37**

g016926

- |                   |                                    |                                    |                        |
|-------------------|------------------------------------|------------------------------------|------------------------|
| 1. Shaft adjuster | 4. Apply anti-seize compound here. | 7. Apply anti-seize compound here. | 10. Compression spring |
| 2. Wave washer    | 5. Flat washer                     | 8. Bedbar-adjuster screw           | 11. Spring-tension nut |
| 3. Flange bushing | 6. Locknut                         | 9. Hardened washer                 |                        |

6. Apply anti-seize compound to the threads of the bedbar-adjuster screw that fit into the adjuster shaft.
7. Thread the bedbar-adjuster screw into the adjuster shaft.
8. Loosely install the hardened washer, spring, and spring-tension nut onto the adjuster screw.
9. Install the bedbar, positioning the mounting ears between the washer and the bedbar adjuster.
10. Secure the bedbar to each side plate with the bedbar bolts (nuts on bolts) and 6 washers.

**Note:** Position a nylon washer on each side of the side plate boss.

Place a steel washer outside each of the nylon washers ([Figure 37](#)).

Torque the bedbar bolts to 37 to 45 N·m (27 to 33 ft-lb). Tighten the locknuts until the outside steel washer stops rotating and end play is removed, but do not overtighten or deflect the side plates. The washers on the inside may have a gap.

11. Tighten the nut on each bedbar-adjuster assembly until the compression spring is fully compressed, then loosen the nut 1/2 turn ([Figure 37](#)).
12. Repeat the procedure on the other end of the cutting unit.
13. Adjust the bedknife to the reel.

# Servicing the Roller

The Roller Rebuild Kit and the Roller Rebuild Tool Kit (Figure 38) are available for servicing the roller. The Roller Rebuild Kit includes all the bearings, bearing

nuts, inner seals, and outer seals to rebuild a roller. The Roller Rebuild Tool Kit includes all the tools and the installation instructions required to rebuild a roller with the Roller Rebuild Kit. Refer to your *Parts Catalog* or contact your distributor for assistance.

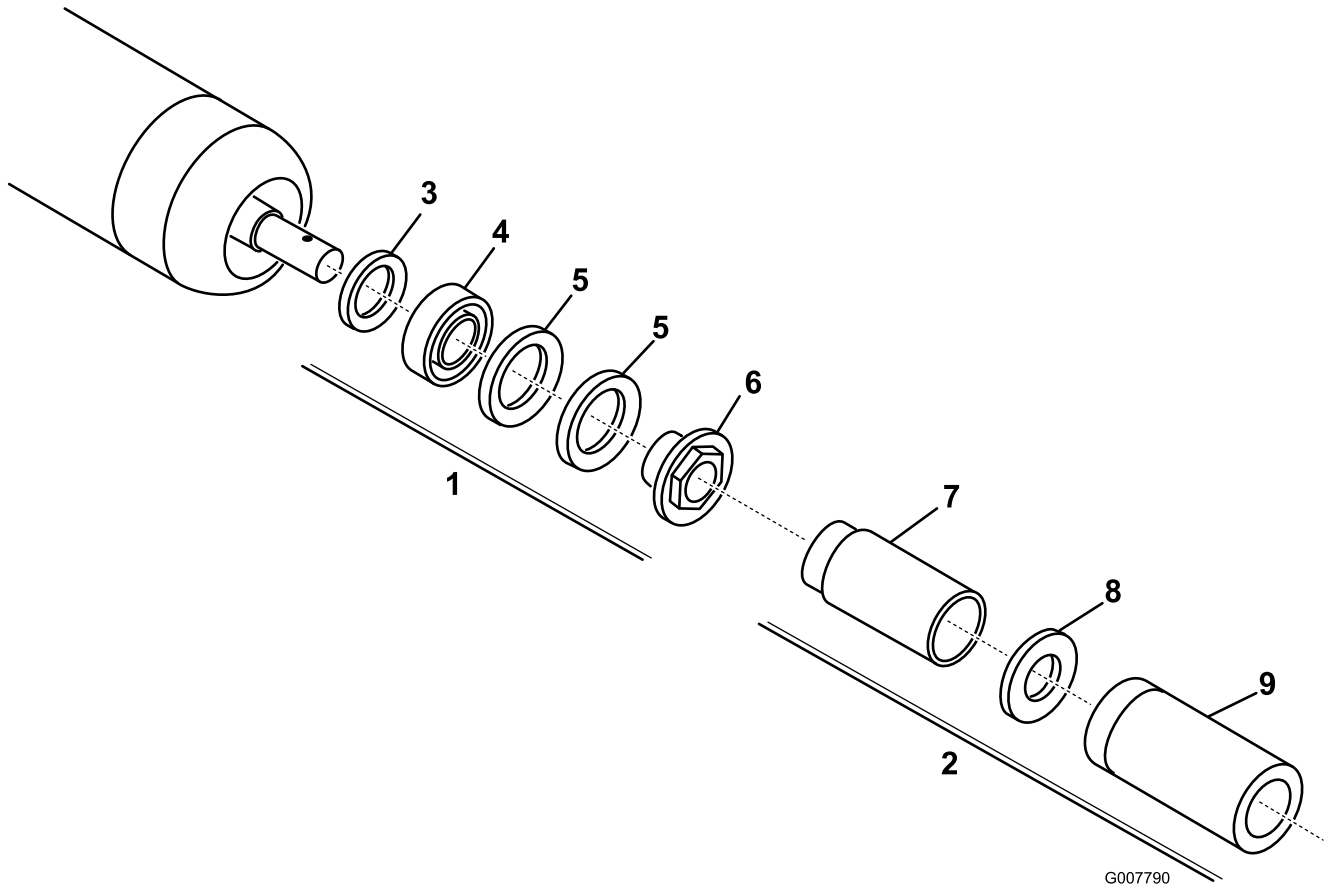

G007790

g007790

**Figure 38**

- |   |                            |
|---|----------------------------|
| 1. Rebuild kit (Part No.114-5430)       | 6. Bearing nut             |
| 2. Rebuild tool kit (Part No. 115-0803) | 7. Inner-seal tool         |
| 3. Inner seal                           | 8. Washer                  |
| 4. Bearing                              | 9. Bearing/outer-seal tool |
| 5. Outer seal                           |                            |

**Notes:**

# Declaration of Incorporation

The Toro Company, 8111 Lyndale Ave. South, Bloomington, MN, USA declares that the following unit(s) conform(s) to the directives listed, when installed in accordance with the accompanying instructions onto certain Toro models as indicated on the relevant Declarations of Conformity.

Model No.	Serial No.	Product Description	Invoice Description	General Description	Directive
03721	403447001 and Up	27-inch 8-Blade Edge Series Cutting Unit, Reelmaster 7000-D Traction Unit	RM7000 27IN 8-BLADE ES (RR) DPA CU	Cutting Unit	2000/14/EC 2006/42/EC
03722	403447001 and Up	27-inch Edge Series 11-Blade Cutting Unit, Reelmaster 7000-D Traction Unit	RM7000 27IN 11-BLADE ES (RR) DPA CU	Cutting Unit	2000/14/EC 2006/42/EC
03727	403447001 and Up	32-inch 8-Blade Edge Series Cutting Unit, Reelmaster 7000-D Traction Unit	RM7000 32IN 8-BLADE ES (RR) DPA CU	Cutting Unit	2000/14/EC 2006/42/EC

Relevant technical documentation has been compiled as required per Part B of Annex VII of 2006/42/EC.

We will undertake to transmit, in response to requests by national authorities, relevant information on this partly completed machinery. The method of transmission shall be electronic transmittal.

This machinery shall not be put into service until incorporated into approved Toro models as indicated on the associated Declaration of Conformity and in accordance with all instructions, whereby it can be declared in conformity with all relevant Directives.

Certified:



John Heckel  
Sr. Engineering Manager  
8111 Lyndale Ave. South  
Bloomington, MN 55420, USA  
January 31, 2019

Authorized Representative:

Marcel Dutrieux  
Manager European Product Integrity  
Toro Europe NV  
Nijverheidsstraat 5  
2260 Oevel  
Belgium

## EEA/UK Privacy Notice

### **Toro's Use of Your Personal Information**

The Toro Company ("Toro") respects your privacy. When you purchase our products, we may collect certain personal information about you, either directly from you or through your local Toro company or dealer. Toro uses this information to fulfil contractual obligations - such as to register your warranty, process your warranty claim or to contact you in the event of a product recall - and for legitimate business purposes - such as to gauge customer satisfaction, improve our products or provide you with product information which may be of interest. Toro may share your information with our subsidiaries, affiliates, dealers or other business partners in connection these activities. We may also disclose personal information when required by law or in connection with the sale, purchase or merger of a business. We will never sell your personal information to any other company for marketing purposes.

### **Retention of your Personal Information**

Toro will keep your personal information as long as it is relevant for the above purposes and in accordance with legal requirements. For more information about applicable retention periods please contact [legal@toro.com](mailto:legal@toro.com).

### **Toro's Commitment to Security**

Your personal information may be processed in the US or another country which may have less strict data protection laws than your country of residence. Whenever we transfer your information outside of your country of residence, we will take legally required steps to ensure that appropriate safeguards are in place to protect your information and to make sure it is treated securely.

### **Access and Correction**

You may have the right to correct or review your personal data, or object to or restrict the processing of your data. To do so, please contact us by email at [legal@toro.com](mailto:legal@toro.com). If you have concerns about the way in which Toro has handled your information, we encourage you to raise this directly with us. Please note that European residents have the right to complain to your Data Protection Authority.



# The Toro Warranty

Two-Year or 1,500 Hours Limited Warranty

## Conditions and Products Covered

The Toro Company and its affiliate, Toro Warranty Company, pursuant to an agreement between them, jointly warrant your Toro Commercial product ("Product") to be free from defects in materials or workmanship for 2 years or 1,500 operational hours\*, whichever occurs first. This warranty is applicable to all products with the exception of Aerators (refer to separate warranty statements for these products). Where a warrantable condition exists, we will repair the Product at no cost to you including diagnostics, labor, parts, and transportation. This warranty begins on the date the Product is delivered to the original retail purchaser.

\* Product equipped with an hour meter.

## Instructions for Obtaining Warranty Service

You are responsible for notifying the Commercial Products Distributor or Authorized Commercial Products Dealer from whom you purchased the Product as soon as you believe a warrantable condition exists. If you need help locating a Commercial Products Distributor or Authorized Dealer, or if you have questions regarding your warranty rights or responsibilities, you may contact us at:

Toro Commercial Products Service Department  
Toro Warranty Company  
8111 Lyndale Avenue South  
Bloomington, MN 55420-1196  
952-888-8801 or 800-952-2740  
E-mail: commercial.warranty@toro.com

## Owner Responsibilities

As the product owner, you are responsible for required maintenance and adjustments stated in your *Operator's Manual*. Repairs for product issues caused by failure to perform required maintenance and adjustments are not covered under this warranty.

## Items and Conditions Not Covered

Not all product failures or malfunctions that occur during the warranty period are defects in materials or workmanship. This warranty does not cover the following:

- Product failures which result from the use of non-Toro replacement parts, or from installation and use of add-on, or modified non-Toro branded accessories and products.
- Product failures which result from failure to perform recommended maintenance and/or adjustments.
- Product failures which result from operating the Product in an abusive, negligent, or reckless manner.
- Parts consumed through use that are not defective. Examples of parts which are consumed, or used up, during normal Product operation include, but are not limited to, brake pads and linings, clutch linings, blades, reels, rollers and bearings (sealed or greasable), bed knives, spark plugs, castor wheels and bearings, tires, filters, belts, and certain sprayer components such as diaphragms, nozzles, and check valves.
- Failures caused by outside influence, including, but not limited to, weather, storage practices, contamination, use of unapproved fuels, coolants, lubricants, additives, fertilizers, water, or chemicals.
- Failure or performance issues due to the use of fuels (e.g. gasoline, diesel, or biodiesel) that do not conform to their respective industry standards.
- Normal noise, vibration, wear and tear, and deterioration. Normal "wear and tear" includes, but is not limited to, damage to seats due to wear or abrasion, worn painted surfaces, scratched decals or windows.

## Countries Other than the United States or Canada

Customers who have purchased Toro products exported from the United States or Canada should contact their Toro Distributor (Dealer) to obtain guarantee policies for your country, province, or state. If for any reason you are dissatisfied with your Distributor's service or have difficulty obtaining guarantee information, contact your Authorized Toro Service Center.

## Parts

Parts scheduled for replacement as required maintenance are warranted for the period of time up to the scheduled replacement time for that part. Parts replaced under this warranty are covered for the duration of the original product warranty and become the property of Toro. Toro will make the final decision whether to repair any existing part or assembly or replace it. Toro may use remanufactured parts for warranty repairs.

## Deep Cycle and Lithium-Ion Battery Warranty

Deep cycle and Lithium-Ion batteries have a specified total number of kilowatt-hours they can deliver during their lifetime. Operating, recharging, and maintenance techniques can extend or reduce total battery life. As the batteries in this product are consumed, the amount of useful work between charging intervals will slowly decrease until the battery is completely worn out. Replacement of worn out batteries, due to normal consumption, is the responsibility of the product owner. Note: (Lithium-Ion battery only): Pro-rated after 2 years. Refer to the battery warranty for additional information.

## Lifetime Crankshaft Warranty (ProStripe 02657 Model Only)

The Prostripe which is fitted with a genuine Toro Friction Disc and Crank-Safe Blade Brake Clutch (integrated Blade Brake Clutch (BBC) + Friction Disc assembly) as original equipment and used by the original purchaser in accordance with recommended operating and maintenance procedures, are covered by a Lifetime Warranty against engine crankshaft bending. Machines fitted with friction washers, Blade Brake Clutch (BBC) units and other such devices are not covered by the Lifetime Crankshaft Warranty.

## Maintenance is at Owner's Expense

Engine tune-up, lubrication, cleaning and polishing, replacement of filters, coolant, and completing recommended maintenance are some of the normal services Toro products require that are at the owner's expense.

## General Conditions

Repair by an Authorized Toro Distributor or Dealer is your sole remedy under this warranty.

**Neither The Toro Company nor Toro Warranty Company is liable for indirect, incidental or consequential damages in connection with the use of the Toro Products covered by this warranty, including any cost or expense of providing substitute equipment or service during reasonable periods of malfunction or non-use pending completion of repairs under this warranty. Except for the Emissions warranty referenced below, if applicable, there is no other express warranty. All implied warranties of merchantability and fitness for use are limited to the duration of this express warranty.**

Some states do not allow exclusions of incidental or consequential damages, or limitations on how long an implied warranty lasts, so the above exclusions and limitations may not apply to you. This warranty gives you specific legal rights, and you may also have other rights which vary from state to state.

## Note Regarding Emissions Warranty

The Emissions Control System on your Product may be covered by a separate warranty meeting requirements established by the U.S. Environmental Protection Agency (EPA) and/or the California Air Resources Board (CARB). The hour limitations set forth above do not apply to the Emissions Control System Warranty. Refer to the Engine Emission Control Warranty Statement supplied with your product or contained in the engine manufacturer's documentation.