



Count on it.

Operator's Manual

**8, 11, and 14-Blade EdgeSeries
DPA Cutting Units**

**Greensmaster® 3300 or 3400 Series Traction
Unit**

Model No. 04651—Serial No. 403460001 and Up

Model No. 04653—Serial No. 403460001 and Up

Model No. 04655—Serial No. 403460001 and Up



This product complies with all relevant European directives. For details, please see the Declaration of Incorporation (DOI) at the back of this publication.

(Figure 2), which signals a hazard that may cause serious injury or death if you do not follow the recommended precautions.

Introduction

This cutting unit is designed for cutting turf on greens and small fairways of golf courses. Using this product for purposes other than its intended use could prove dangerous to you and bystanders.

Read this information carefully to learn how to operate and maintain your product properly and to avoid injury and product damage. You are responsible for operating the product properly and safely.

Visit www.Toro.com for product safety and operation training materials, accessory information, help finding a dealer, or to register your product.

Whenever you need service, genuine Toro parts, or additional information, contact an Authorized Service Dealer or Toro Customer Service and have the model and serial numbers of your product ready. Figure 1 identifies the location of the model and serial numbers on the product. Write the numbers in the space provided.



g000502

Figure 2
Safety-alert symbol

This manual uses 2 words to highlight information. **Important** calls attention to special mechanical information and **Note** emphasizes general information worthy of special attention.

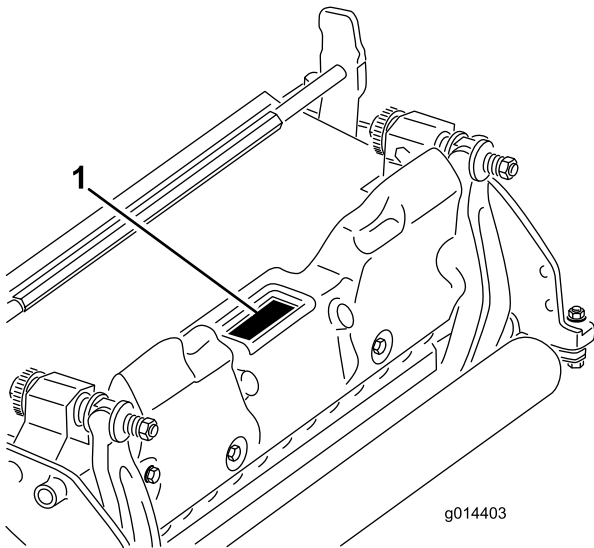

g014403

g014403

Figure 1

1. Model and serial number location

Model No. _____
Serial No. _____

This manual identifies potential hazards and has safety messages identified by the safety-alert symbol

Contents

Safety	3
General Safety	3
Cutting Unit Safety	4
Blade Safety	4
Safety and Instructional Decals	4
Setup	5
Installing the Roller	5
Adjusting the Cutting Unit	5
Product Overview	6
Specifications	6
Attachments/Accessories	6
Operation	6
Adjusting the Cutting Unit	6
Maintenance	11
Supporting the Cutting Unit.....	11
Servicing the Bedbar	11
Bedknife Specifications	13
Backlapping the Cutting Unit.....	15

Safety

This machine has been designed in accordance with EN ISO 5395 and ANSI B71.4–2017.

General Safety

This product is capable of amputating hands and feet. Always follow all safety instructions to avoid serious personal injury.

- Read and understand the contents of this *Operator's Manual* before starting the engine.
- Do not put your hands or feet near moving components of the machine.
- Do not operate the machine without all guards and other safety protective devices in place and working on the machine.
- Keep clear of any discharge opening. Keep bystanders and pets a safe distance away from the machine.
- Keep children out of the operating area. Never allow children to operate the machine.
- Park the machine on a level surface, lower the cutting units, disengage the drives, engage the parking brake (if provided), shut off the engine, and remove the key before leaving the operator's position for any reason.

Improperly using or maintaining this machine can result in injury. To reduce the potential for injury, comply with these safety instructions and always pay attention to the safety-alert symbol , which means Caution, Warning, or Danger—personal safety instruction. Failure to comply with these instructions may result in personal injury or death.

Cutting Unit Safety

- The cutting unit is only a part of a complete machine when installed on a traction unit. Read the traction unit *Operator's Manual* carefully for complete instructions on the safe use of the machine.
- Stop the machine, remove the key, and wait for all moving parts to stop before inspecting the attachment after striking an object or if there is an abnormal vibration in the machine. Make all necessary repairs before resuming operation.
- Keep all parts in good working condition and all hardware tightened. Replace all worn or damaged decals.
- Use only accessories, attachments, and replacement parts approved by Toro.

Blade Safety

A worn or damaged reel blade or bedknife can break, and a piece of it could be thrown toward you or bystanders, resulting in serious personal injury or death.

- Inspect the reel and bedknife periodically for wear or damage.
- Use care and wear gloves when checking or servicing the reel and bedknife.
- On machines with multiple cutting units, take care as rotating 1 reel can cause other reels to rotate.

Safety and Instructional Decals



Safety decals and instructions are easily visible to the operator and are located near any area of potential danger. Replace any decal that is damaged or missing.

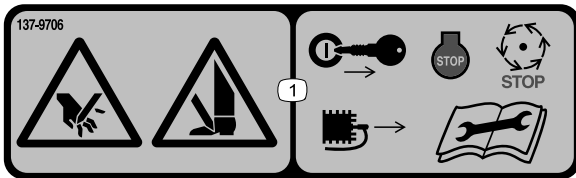

137-9706

decal137-9706

1. Cutting hazard of the hand or foot—shut off the engine, remove the key, wait for all moving parts to stop, disconnect the spark plug, and read the *Operator's Manual* before performing maintenance.

Setup

Media and Additional Parts

Description	Qty.	Use
Operator's Manual	1	Read before installing and operating the cutting unit.

Installing the Roller

The cutting unit is shipped without a front roller. Obtain a roller from your dealer and install it on the cutting unit, as follows:

1. Remove the plow bolt, washer, and flange nut securing one of the height-of-cut arms to the cutting unit side plate ([Figure 3](#)).

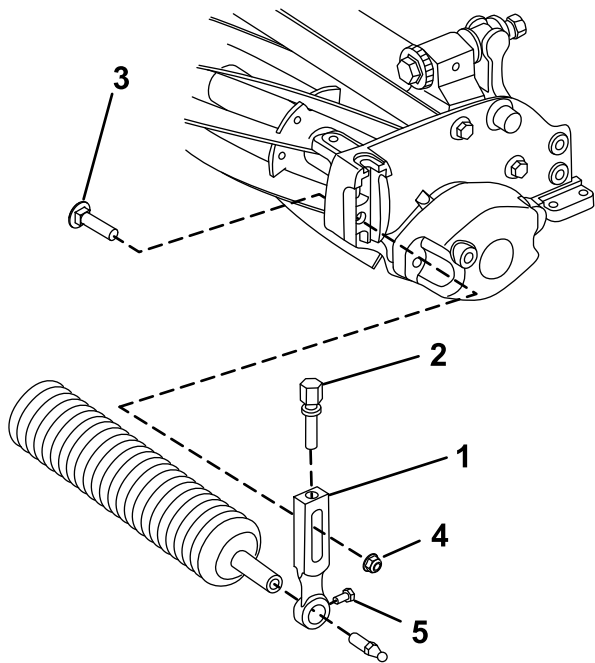

Figure 3

g278288

1. Height-of-cut arm
2. Adjusting screw
3. Plow bolt
4. Flange nut
5. Roller-mounting screw

2. Loosen the roller-mounting screws in the height-of-cut arms ([Figure 3](#)).
3. Slide the roller shaft into the height-of-cut arm on the opposite end of the cutting unit ([Figure 3](#)).
4. Slide the height-of-cut arm onto the roller shaft ([Figure 3](#)).
5. Loosely secure the roller to the cutting unit with the height-of-cut arm and fasteners previously removed ([Figure 3](#)).
6. Center the roller between the height-of-cut arms.
7. Tighten the roller-mounting screws ([Figure 3](#)).

8. Adjust to the desired height-of-cut and tighten the height-of-cut arm mounting fasteners.

Adjusting the Cutting Unit

1. Support the cutting unit; refer to [Supporting the Cutting Unit \(page 11\)](#).
2. Adjust the bedknife to the reel.
3. Adjust the rear roller height.
4. Adjust the height of cut.
5. Adjust the cut-off bar.

Refer to [Adjusting the Cutting Unit \(page 5\)](#) for complete instructions for performing these adjustments.

Product Overview

Specifications

Model Number	Weight
04651	32 kg (71 lb)
04653	34 kg (74 lb)
04655	35 kg (77 lb)

Attachments/Accessories

A selection of Toro approved attachments and accessories is available for use with the machine to enhance and expand its capabilities. Contact your Authorized Service Dealer or authorized Toro distributor or go to www.Toro.com for a list of all approved attachments and accessories.

To ensure optimum performance and continued safety certification of the machine, use only genuine Toro replacement parts and accessories. Replacement parts and accessories made by other manufacturers could be dangerous, and such use could void the product warranty.

Operation

Refer to your traction unit *Operator's Manual* for detailed operation instructions. Before using the cutting unit each day, adjust the bedknife; refer to [Adjusting the Bedknife Daily \(page 6\)](#). Test the quality of cut by cutting a test swath before using the cutting unit to ensure that the finished cut is correct.

Adjusting the Cutting Unit

Adjusting the Bedknife-to-Reel Contact

Adjusting the Bedknife Daily

Prior to mowing each day, or as required, verify proper bedknife-to-reel contact. **Perform this procedure even though the quality of cut is acceptable.**

1. Lower the cutting units onto a hard surface, shut off the engine, and remove the ignition key.
2. Slowly rotate the reel in a reverse direction, listening for reel-to-bedknife contact.
 - If no contact is evident, adjust the bedknife as follows:
 - A. Turn the bedbar adjusting screws clockwise ([Figure 4](#)), 1 click at a time, until you feel and hear light contact.

Note: The bedbar adjusting screws have detents corresponding to 0.018 mm (0.0007 inch) bedknife movement for each indexed position.

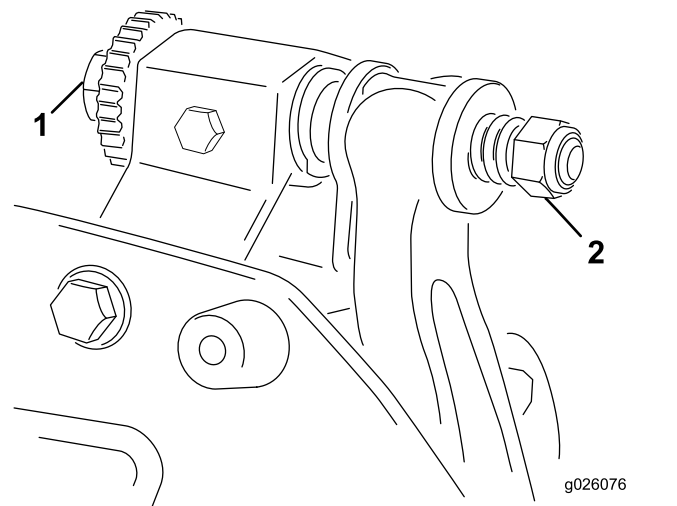

Figure 4

1. Bedbar adjusting screw
2. Bedbar-adjusting-screw nut (2)

- B. Insert a long strip of cutting performance paper between the reel and bedknife, perpendicular to the bedknife (Figure 5), then **slowly** rotate the reel forward; it should cut the paper; if not, repeat steps A and B until it does.
- If excessive contact/reel drag is evident, backlap, reface the front of the bedknife, or grind the cutting unit to achieve the sharp edges needed for precision cutting (Refer to the *Toro Manual for Sharpening Reel and Rotary Mowers*, Form No. 09168SL).

Important: Light contact is preferred at all times. If you do not maintain light contact, the bedknife/reel edges will not sufficiently self-sharpen, and dull cutting edges will result after a period of operation. If you maintain excessive contact, bedknife/reel wear will be accelerated, uneven wear can result, and the quality of cut may decline.

Note: As the reel blades continue to run against the bedknife, a slight burr will appear on the front cutting edge surface along the full length of the bedknife. Occasionally run a file across the front edge to remove this burr to improve cutting. After extended running, a ridge will eventually develop at both ends of the bedknife. Round off these notches or file them flush with the cutting edge of the bedknife to ensure smooth operation.

Adjusting the Bedknife to the Reel

Use this procedure during initial cutting-unit setup and after grinding, backlapping, or disassembling the reel. This is not a daily adjustment.

1. Position the cutting unit on a flat, level work surface.
2. Tip the cutting unit to expose the bedknife and reel.

Note: Ensure that the nuts on the back of the bedbar adjusting bolts are not resting on the work surface (Figure 12).

3. Rotate the reel so that 1 of the blades crosses the bedknife edge between the first and second bedknife bolt heads located on the right side of the cutting unit.
4. Make an identifying mark on the blade where it crosses the bedknife edge.

Note: This will make later adjustments easier.

5. Insert a 0.05 mm (0.002 inch) shim between the blade and the bedknife edge at the point marked in step 4.
6. Turn the right bedbar adjusting bolt (Figure 4) until you feel light pressure on the shim when sliding it side-to-side. Remove the shim.
7. For the left side of the cutting unit, slowly rotate the reel so that the closest blade crosses the bedknife edge between the first and second bolt heads.
8. Repeat steps 4 through 6 for the left side of the cutting unit and left bedbar adjusting bolt.
9. Repeat steps 5 and 6 until there is light pressure at the contact points on both the left and right sides of the cutting unit.
10. To obtain light contact between the reel and bedknife, turn each bedbar adjusting bolt clockwise 3 clicks.

Note: Each click on the bedbar adjusting bolt moves the bedknife 0.018 mm (0.0007 inches).

Do not overtighten the adjusting bolts.

Turning the adjusting bolt clockwise moves the bedknife edge closer to the reel. Turning the adjusting bolt counterclockwise moves the bedknife edge away from the reel.

11. Insert a long strip of cutting performance paper between the reel and bedknife, perpendicular to the bedknife (Figure 5), then **slowly** rotate the reel forward; it should cut the paper; if not, turn each bedbar adjusting bolt clockwise 1 click and repeat this step until it cuts the paper.

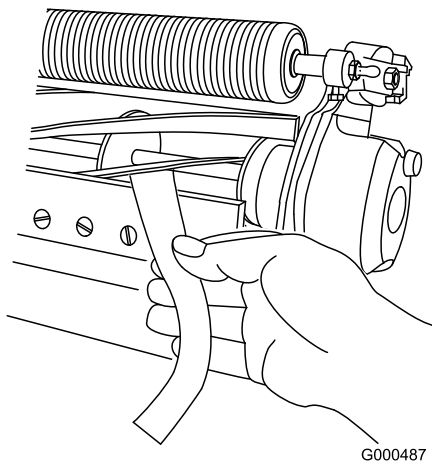

Figure 5

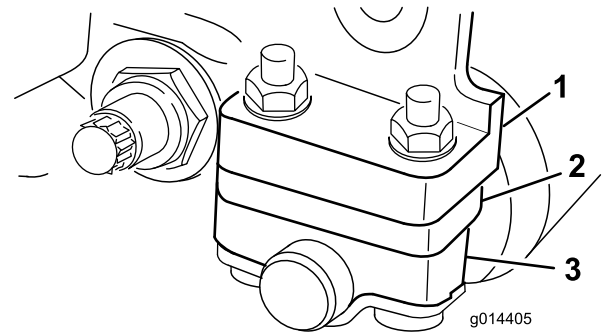

Figure 7

1. Sideplate-mounting flange
2. Spacer
3. Roller bracket

Note: If excessive contact/reel drag is evident, backlap, reface the front of the bedknife, or grind the cutting unit to achieve the sharp edges needed for precision cutting (Refer to the *Toro Manual for Sharpening Reel and Rotary Mowers*, Form No. 09168SL).

Adjusting the Rear-Roller Height

Depending on your desired height-of-cut range, you need to adjust the rear-roller brackets (Figure 6 or Figure 7) to the low or high position:

- Position the spacer above the sideplate-mounting flange (factory setting) when the height-of-cut settings range from 1.5 mm to 6 mm (1/16 inch to 1/4 inch) as shown in Figure 6.

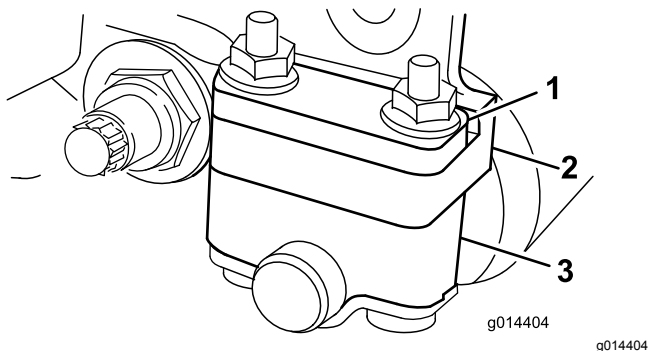

Figure 6

1. Spacer
2. Sideplate-mounting flange
3. Roller bracket

- Position the spacer below the sideplate-mounting flange when the height-of-cut settings range from 3 mm to 25 mm (1/8 inch to 1 inch) as shown in Figure 7.

1. Raise the rear of the cutting unit and place a block under the bedknife.
2. Remove the 2 nuts securing each roller bracket and spacer to each sideplate mounting flange.
3. Lower the roller and bolts from the sideplate mounting flanges and spacers.
4. Place the spacers onto the bolts above or below the roller brackets, as required (Figure 6 or Figure 7).
5. Secure the roller bracket and spacers to the underside of the mounting flanges with the nuts previously removed.

Note: The position of the rear roller to the reel is controlled by the machining tolerances of the assembled components and paralleling is not required.

Adjusting the Height of Cut

Use the following chart to determine which bedknife is best suited for the desired height of cut.

Bedknife	Part No.	Height-of-Cut
Edgemax Micro-cut (Standard)	115-1880	1.5 to 4.7 mm (0.062 to 0.188 inch)
Edgemax Tournament (Optional)	115-1881	3.1 to 12.7 mm (0.125 to 0.500 inch)
Micro-cut (Optional)	93-4262	1.5 to 4.7 mm (0.062 to 0.188 inch)
Tournament (Optional)	93-4263	3.1 to 12.7 mm (0.125 to 0.500 inch)
Extended Micro-cut (Optional)	108-4303	1.5 to 4.7 mm (0.062 to 0.188 inch)
Extended Tournament (Optional)	108-4302	3.1 to 12.7 mm (0.125 to 0.500 inch)

Low-cut (Optional)	93-4264	4.7 to 25.4 mm (0.188 to 1.00 inch)
High-cut (Optional)	94-6392	7.9 to 25.4 mm (0.312 to 1.00 inch)
Fairway (Optional)	63-8610	9.5 to 25.4 mm (0.375 to 1.00 inch)
Fairway EdgeMax (optional)	137-0879	9.5 to 25.4 mm (0.375 to 1.00 inch)

Note: For heights of cut greater than 9.5 mm (0.375 inch), install the high-height-of-cut kit.

Adjusting the Height-of-Cut Gauge

Before adjusting the height of cut, set the height-of-cut gauge as follows:

1. Loosen the nut on the gauge bar and set the adjusting bolt to the desired height of cut (Figure 8).

Note: The distance between the bottom of the bolt head and the face of bar is the height of cut.

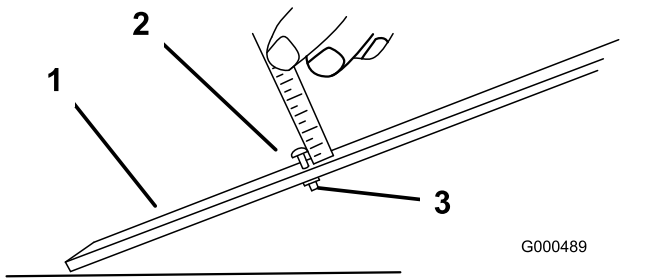

Figure 8

1. Gauge bar
2. Height-adjusting bolt
3. Nut

2. Tighten the nut.

Adjusting the Height of Cut

1. Loosen the locknuts securing the height-of-cut arms to the cutting-unit side plates (Figure 9).

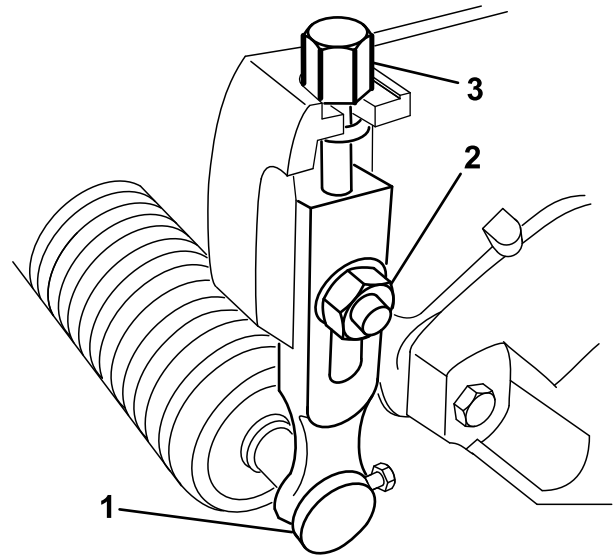

Figure 9

1. Height-of-cut arm
2. Flange locknut
3. Adjusting bolt

2. Hook the bolt head of the height-of-cut gauge onto the right side of the cutting edge of the bedknife and rest the rear end of the bar onto the rear of the roller (Figure 10).

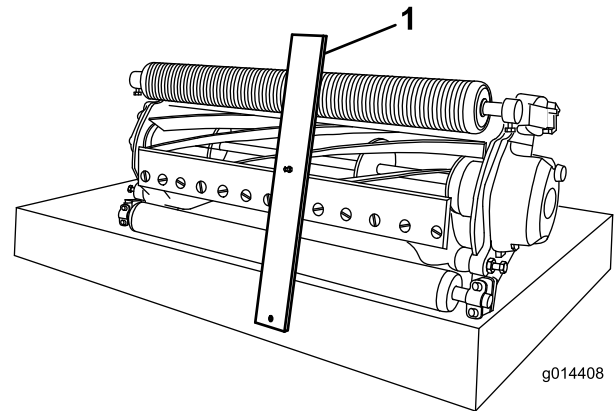

Figure 10

1. Gauge bar
3. Rotate the adjusting bolt until the roller contacts the front of the gauge bar.
4. Repeat steps 2 and 3 for the left side.
5. Adjust both ends of the roller until the entire roller is parallel to the bedknife.

Important: When set properly, the rear and front rollers will contact the gauge bar and the bolt will be snug against the bedknife. This ensures that the height of cut is identical at both ends of the bedknife.

6. Tighten the nuts to secure the adjustment enough to remove play from the washer.

7. Verify that the height-of-cut setting is correct; repeat this procedure if necessary.

Adjusting the Cut-Off Bar

Adjust the cut-off bar to ensure that the clippings are cleanly discharged from the reel area, as follows:

Note: The bar is adjustable to compensate for changes in turf conditions. Adjust the bar closer to the reel when the turf is extremely dry. By contrast, adjust the bar further away from the reel when the turf conditions are wet. The bar should be parallel to the reel to ensure optimum performance. Adjust it after the reel is sharpened on a reel grinder.

1. Loosen the bolts securing the top bar (Figure 11) to the cutting unit.

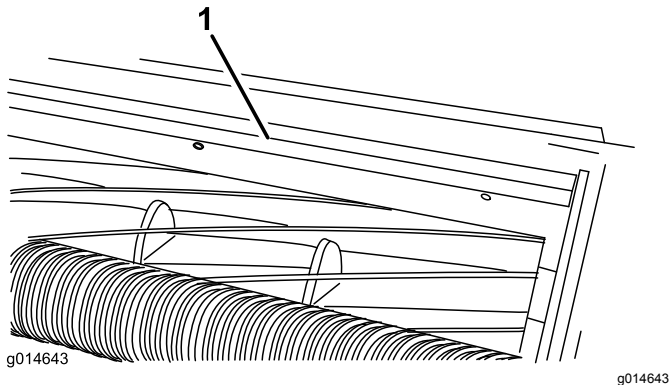

Figure 11

1. Cut-off bar

-
2. Insert a 1.5 mm (0.060 inch) feeler gauge between the top of the reel and the bar then tighten the bolts.

Important: Ensure that the bar and reel are equal distance apart across the complete reel.

Note: Adjust the gap as needed for your turf conditions.

Maintenance

Note: Determine the left and right sides of the machine from the normal operating position.

Supporting the Cutting Unit

Whenever you need to tip the cutting unit to expose the bedknife/reel, prop up the rear of the cutting unit to ensure that the nuts on the back end of the bedbar-adjusting bolts are not resting on the work surface (Figure 12).

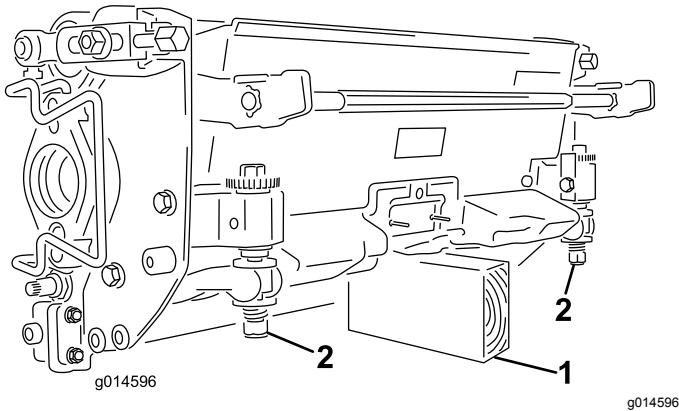

Figure 12

1. Prop (not provided)
2. Bedbar-adjusting-screw nut (2)

Servicing the Bedbar

Only a properly trained mechanic should service the bedbar and bedknife to prevent damage to the reel, bedbar, or bedknife. Ideally, take the cutting unit to your authorized Toro distributor for service. Refer to the *Service Manual* for your traction unit for complete instructions, special tools, and diagrams for servicing the bedknife. Should you ever need to remove or assemble the bedbar yourself, instructions are provided below, as are the specifications for servicing the bedknife.

Important: Always follow the bedknife procedures detailed in your *Service Manual* when servicing the bedknife. Failure to install and grind the bed knife correctly can lead to damage to the reel, bedbar, or bedknife.

Removing the Bedbar

1. Turn the bedbar adjusting screw, counterclockwise, to back the bedknife away from the reel (Figure 13).

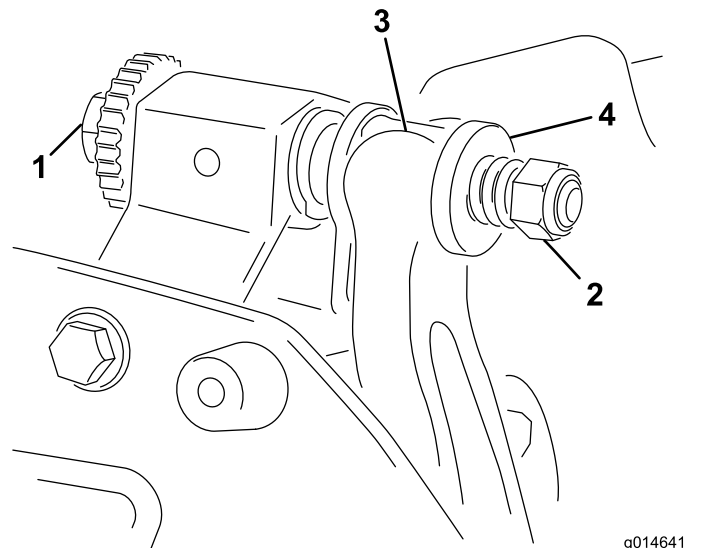

Figure 13

1. Bedbar-adjusting screw
2. Spring-tension nut
3. Bedbar
4. Washer

2. Back out the spring-tension nut until the washer is no longer tensioned against the bedbar (Figure 13).
3. On each side of the machine, loosen the locknut securing the bedbar bolt (Figure 14).

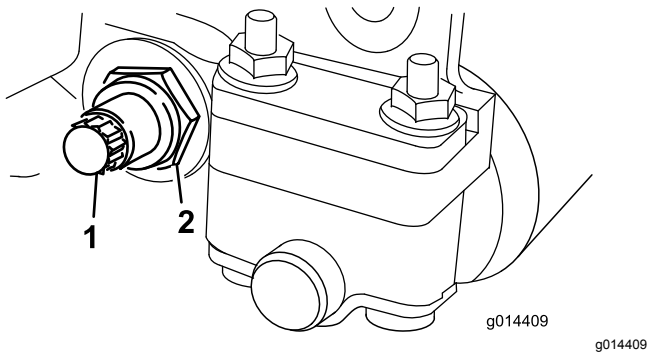

Figure 14

- | | |
|----------------|------------|
| 1. Bedbar bolt | 2. Locknut |
|----------------|------------|

- Remove each bedbar bolt allowing the bedbar to be pulled downward and removed from the cutting unit (Figure 14).

Account for the 2 nylon washers and 1 steel washer on each end of the bedbar (Figure 15).

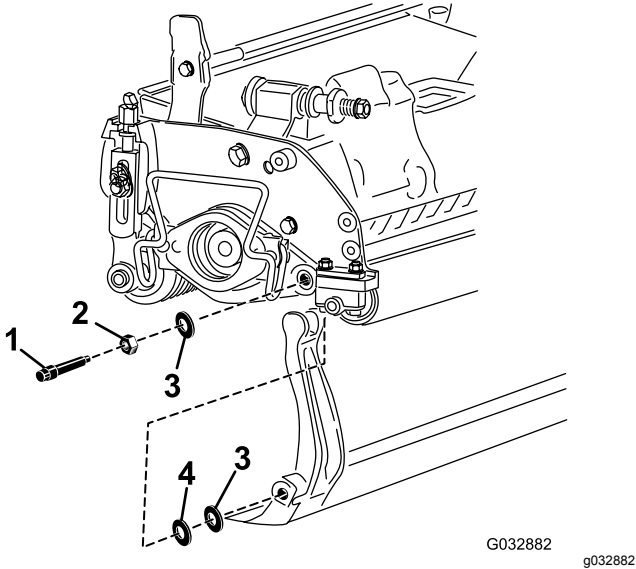

Figure 15

- | | |
|----------------|-----------------|
| 1. Bedbar bolt | 3. Nylon washer |
| 2. Nut | 4. Steel washer |

Assembling the Bedbar

- Install the bedbar, positioning the mounting ears between the washers and the bedbar-adjusting screw (Figure 13).
 - Secure the bedbar to each side plate with the bedbar bolts (nuts on bolts) and 3 washers (6 total).
 - Position a nylon washer on each side of the side-plate boss. Place a steel washer outside each of the nylon washers (Figure 15).
 - Torque the bedbar bolts to 27 to 36 N·m (240 to 320 inch-lb).
 - Tighten the locknuts until you remove the end play from steel washers, but you are able to rotate them by hand. The washers on the inside may have a gap.
- Important: Do not overtighten the locknuts or they will deflect the side plates.**
- Tighten the spring tension nut until the spring is collapsed, then back it off 1/2 turn (Figure 16).

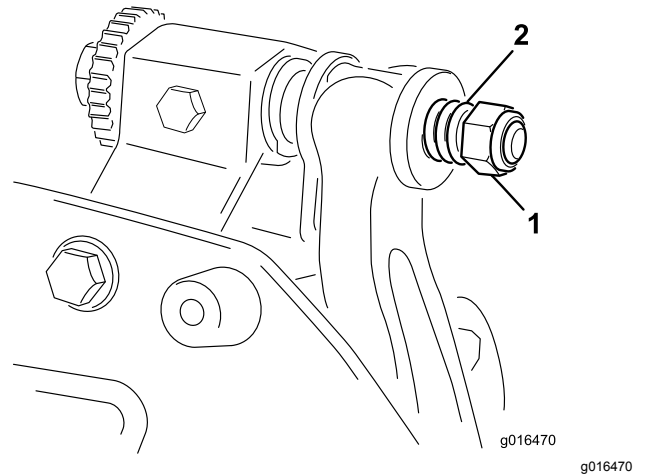

Figure 16

- | | |
|-----------------------|-----------|
| 1. Spring-tension nut | 2. Spring |
|-----------------------|-----------|

- Adjust the bedknife to the reel; refer to [Adjusting the Bedknife-to-Reel Contact](#) (page 6).

Bedknife Specifications

Installing the Bedknife

1. Remove the rust, scale, and corrosion from the bedbar surface and apply a thin layer of oil to the bedbar surface.
2. Clean the screw threads.
3. Apply never-seize compound to the screws and install the bedknife to the bedbar.

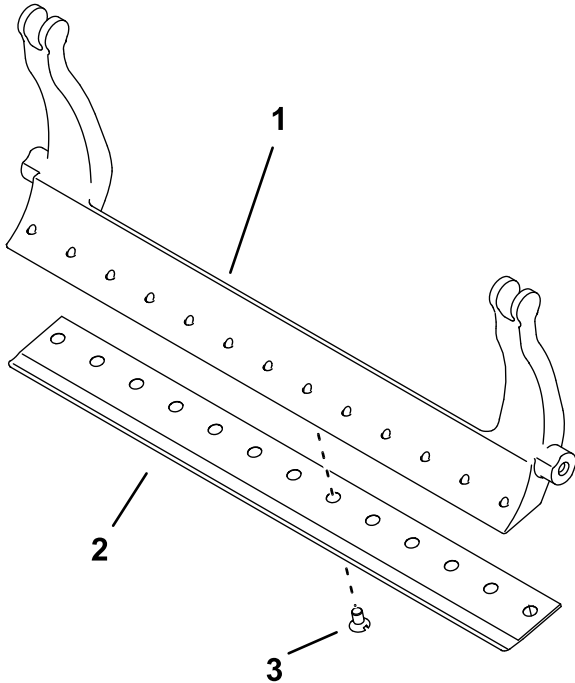

Figure 17

1. Bedbar
2. Bedknife
3. Screw

4. Torque the 2 outer screws to 1 N·m (10 in-lb).
5. Working from the center of the bedknife, torque the screws to 23 to 28 N·m (200 to 250 in-lb).

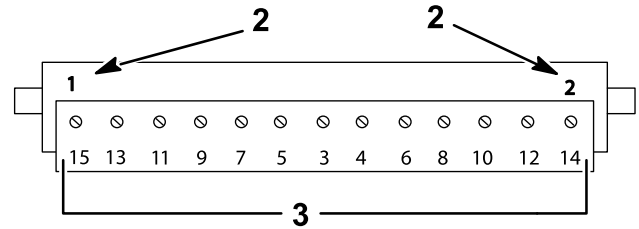
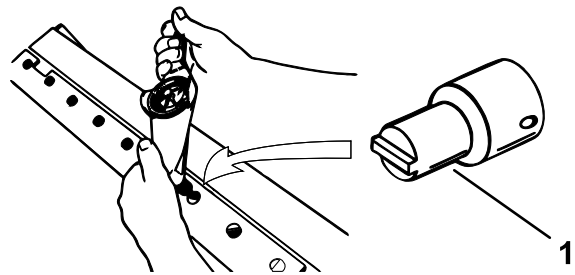

Figure 18

1. Bedknife screw tool
2. Install and torque these first to 1 N·m (10 in-lb).
3. Torque to 23 to 28 N·m (200 to 250 in-lb).

6. Grind the bedknife.

Preparing the Reel for Grinding

1. Ensure that all cutting unit components are in good condition and correct any issues before grinding.
2. Follow the reel grinder manufacturer's instructions to grind the cutting reel to the following specifications.

Reel Grinding Specifications	
New Reel Diameter	128.5 mm (5.06 inches)
Reel Diameter Service Limit	114.3 mm (4-1/2 inches)
Blade Relief Angle	30° ± 5°
Blade Land Width	1.0 mm (0.04 inches)
Blade Land Width Range	.8 to 1.2 mm (0.03 to 0.05 inches)
Reel Diameter Taper Service Limit	0.25 mm (1/100 inch)

Relief-Grinding the Reel

The new reel has a land width of .8 to 1.2 mm (0.03 to 0.05 inches) and a 30° relief grind.

When the land width gets larger than 3 mm (0.120 inch) wide, do the following:

1. Apply a 30° relief grind on all reel blades until the land width is .76 mm (0.030 inch) wide (Figure 19).

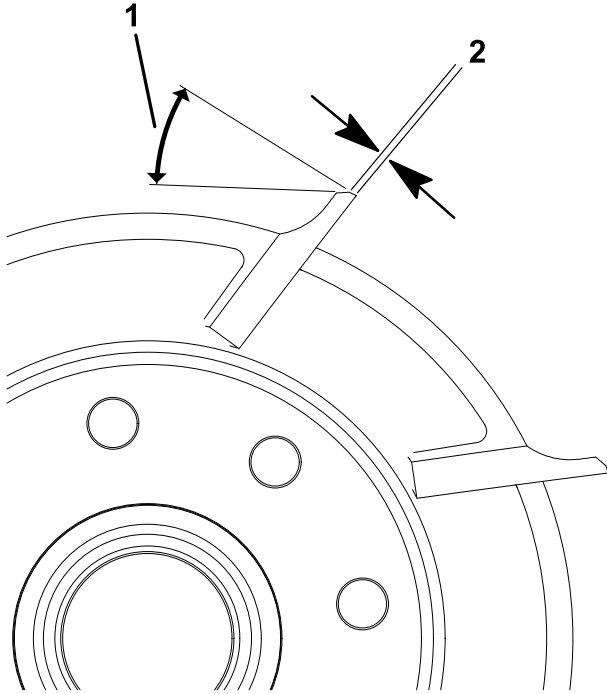

Figure 19

g278332

1. 30°
2. .76 mm (0.030 inch)

2. Spin grind the reel to achieve <0.025 mm (0.001 inch) reel run-out.

Note: This causes the land width to grow slightly.

3. Adjust the cutting unit; refer to your cutting unit *Operator's Manual*.

Note: To extend the longevity of the sharpness of the edge of the reel and the bedknife—after grinding the reel and/or the bedknife—check the reel to bedknife contact again after cutting at the end of each day, as any burrs will be removed, which may create improper reel to bedknife clearance and thus accelerate wear.

Bedknife Grinding Specifications

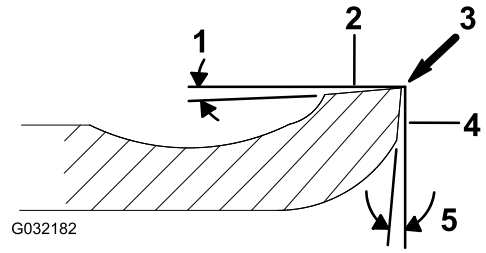

g032182

Figure 20

1. Relief angle
2. Top face
3. Remove burr
4. Front face
5. Front angle

Standard bedknife relief angle	3° minimum
Extended bedknife relief angle	7° minimum
Front Angle Range	13° to 17°

Checking the Top Grind Angle

The angle that you use to grind your bedknives is very important.

Use the angle indicator (Toro Part No. 131-6828) and the angle-indicator mount (Toro Part No. 131-6829) to check the angle that your grinder produces and then correct for any grinder inaccuracy.

1. Place the angle indicator on the bottom side of the bedknife as shown in [Figure 21](#).

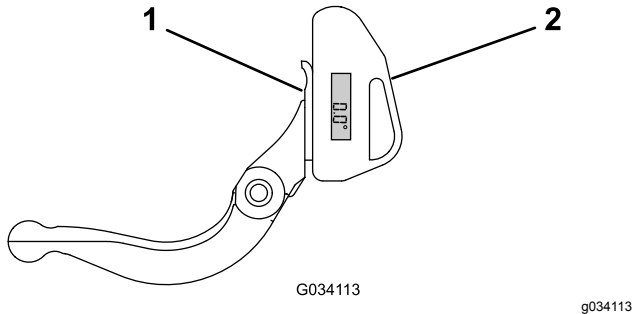

Figure 21

1. Bedknife (vertical)
2. Angle indicator

2. Press the Alt Zero button on the angle indicator.
3. Place the angle-indicator mount on the edge of the bedknife so that the edge of the magnet mates with the edge of the bedknife ([Figure 22](#)).

Note: The digital display should be visible from the same side during this step as it was in step 1.

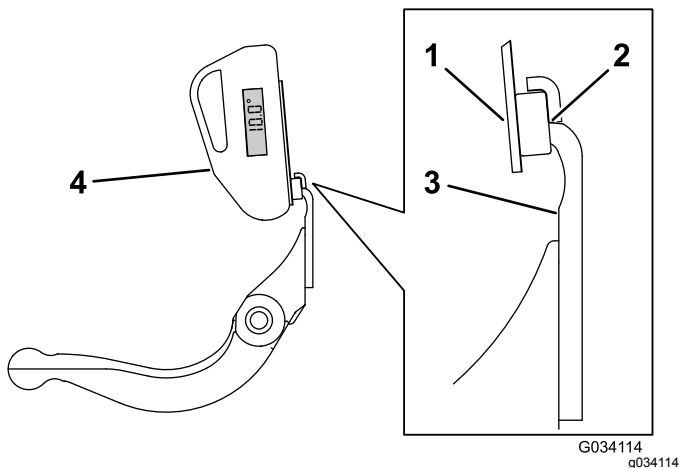

Figure 22

1. Angle-indicator mount
2. Edge of the magnet mated with the edge of the bedknife
3. Bedknife
4. Angle indicator

4. Place the angle indicator on the mount as shown in [Figure 22](#).

Note: This is the angle that your grinder produces, and should be within 2 degrees of the recommended top grind angle.

Backlapping the Cutting Unit

⚠ DANGER

Contact with the reel or other moving parts can result in personal injury.

Keep fingers, hands, and clothing away from the reels or other moving parts.

- Stay away from the reel while backlapping.
- Never use a short-handled paint brush for backlapping. Long-handled brushes are available from your local authorized Toro distributor.

1. Position the machine on a clean, level surface, lower the cutting units, stop the engine, engage the parking brake, and remove the ignition key.
2. Remove the reel motors from the cutting units and disconnect and remove the cutting units from the lift arms.
3. Connect the backlapping machine to the cutting unit by inserting a piece of 3/8 inch square stock into the splined coupling in the end of the cutting unit.

Note: Additional instructions and procedures on Backlapping are available in your traction unit *Operator's Manual* and the *Toro Sharpening Reel and Rotary Mowers Manual*, Form Number 80-300PT.

Note: For a better cutting edge, run a file across the front face of the bedknife and reel when the lapping operation is completed. This will remove any burrs or rough edges that may have built up on the cutting edge.

Notes:

Declaration of Incorporation

The Toro Company, 8111 Lyndale Ave. South, Bloomington, MN, USA declares that the following unit(s) conform(s) to the directives listed, when installed in accordance with the accompanying instructions onto certain Toro models as indicated on the relevant Declarations of Conformity.

Model No.	Serial No.	Product Description	Invoice Description	General Description	Directive
04651	403460001 and Up	8-Blade DPA Reel Mower	8 BLADE DPA-TRIFLEX	8-Blade DPA Reel Mower	2006/42/EC, 2000/14/EC
04653	403460001 and Up	11-Blade DPA Reel Mower	11 BLADE DPA-TRIFLEX	11-Blade DPA Reel Mower	2006/42/EC, 2000/14/EC
04655	403460001 and Up	14-Blade DPA Reel Mower	14 BLADE DPA-TRIFLEX	14-Blade DPA Reel Mower	2006/42/EC, 2000/14/EC

Relevant technical documentation has been compiled as required per Part B of Annex VII of 2006/42/EC.

We will undertake to transmit, in response to requests by national authorities, relevant information on this partly completed machinery. The method of transmission shall be electronic transmittal.

This machinery shall not be put into service until incorporated into approved Toro models as indicated on the associated Declaration of Conformity and in accordance with all instructions, whereby it can be declared in conformity with all relevant Directives.

Certified:



John Heckel
Sr. Engineering Manager
8111 Lyndale Ave. South
Bloomington, MN 55420, USA
December 10, 2018

Authorized Representative:

Marcel Dutrieux
Manager European Product Integrity
Toro Europe NV
Nijverheidsstraat 5
2260 Oevel
Belgium

Tel. +32 16 386 659

EEA/UK Privacy Notice

Toro's Use of Your Personal Information

The Toro Company ("Toro") respects your privacy. When you purchase our products, we may collect certain personal information about you, either directly from you or through your local Toro company or dealer. Toro uses this information to fulfil contractual obligations - such as to register your warranty, process your warranty claim or to contact you in the event of a product recall - and for legitimate business purposes - such as to gauge customer satisfaction, improve our products or provide you with product information which may be of interest. Toro may share your information with our subsidiaries, affiliates, dealers or other business partners in connection these activities. We may also disclose personal information when required by law or in connection with the sale, purchase or merger of a business. We will never sell your personal information to any other company for marketing purposes.

Retention of your Personal Information

Toro will keep your personal information as long as it is relevant for the above purposes and in accordance with legal requirements. For more information about applicable retention periods please contact legal@toro.com.

Toro's Commitment to Security

Your personal information may be processed in the US or another country which may have less strict data protection laws than your country of residence. Whenever we transfer your information outside of your country of residence, we will take legally required steps to ensure that appropriate safeguards are in place to protect your information and to make sure it is treated securely.

Access and Correction

You may have the right to correct or review your personal data, or object to or restrict the processing of your data. To do so, please contact us by email at legal@toro.com. If you have concerns about the way in which Toro has handled your information, we encourage you to raise this directly with us. Please note that European residents have the right to complain to your Data Protection Authority.



The Toro Warranty

Two-Year or 1,500 Hours Limited Warranty

Conditions and Products Covered

The Toro Company and its affiliate, Toro Warranty Company, pursuant to an agreement between them, jointly warrant your Toro Commercial product ("Product") to be free from defects in materials or workmanship for 2 years or 1,500 operational hours*, whichever occurs first. This warranty is applicable to all products with the exception of Aerators (refer to separate warranty statements for these products). Where a warrantable condition exists, we will repair the Product at no cost to you including diagnostics, labor, parts, and transportation. This warranty begins on the date the Product is delivered to the original retail purchaser.

* Product equipped with an hour meter.

Instructions for Obtaining Warranty Service

You are responsible for notifying the Commercial Products Distributor or Authorized Commercial Products Dealer from whom you purchased the Product as soon as you believe a warrantable condition exists. If you need help locating a Commercial Products Distributor or Authorized Dealer, or if you have questions regarding your warranty rights or responsibilities, you may contact us at:

Toro Commercial Products Service Department
Toro Warranty Company
8111 Lyndale Avenue South
Bloomington, MN 55420-1196

952-888-8801 or 800-952-2740
E-mail: commercial.warranty@toro.com

Owner Responsibilities

As the product owner, you are responsible for required maintenance and adjustments stated in your *Operator's Manual*. Repairs for product issues caused by failure to perform required maintenance and adjustments are not covered under this warranty.

Items and Conditions Not Covered

Not all product failures or malfunctions that occur during the warranty period are defects in materials or workmanship. This warranty does not cover the following:

- Product failures which result from the use of non-Toro replacement parts, or from installation and use of add-on, or modified non-Toro branded accessories and products.
- Product failures which result from failure to perform recommended maintenance and/or adjustments.
- Product failures which result from operating the Product in an abusive, negligent, or reckless manner.
- Parts consumed through use that are not defective. Examples of parts which are consumed, or used up, during normal Product operation include, but are not limited to, brake pads and linings, clutch linings, blades, reels, rollers and bearings (sealed or greasable), bed knives, spark plugs, castor wheels and bearings, tires, filters, belts, and certain sprayer components such as diaphragms, nozzles, and check valves.
- Failures caused by outside influence, including, but not limited to, weather, storage practices, contamination, use of unapproved fuels, coolants, lubricants, additives, fertilizers, water, or chemicals.

Countries Other than the United States or Canada

Customers who have purchased Toro products exported from the United States or Canada should contact their Toro Distributor (Dealer) to obtain guarantee policies for your country, province, or state. If for any reason you are dissatisfied with your Distributor's service or have difficulty obtaining guarantee information, contact your Authorized Toro Service Center.

- Failure or performance issues due to the use of fuels (e.g. gasoline, diesel, or biodiesel) that do not conform to their respective industry standards.
- Normal noise, vibration, wear and tear, and deterioration. Normal "wear and tear" includes, but is not limited to, damage to seats due to wear or abrasion, worn painted surfaces, scratched decals or windows.

Parts

Parts scheduled for replacement as required maintenance are warranted for the period of time up to the scheduled replacement time for that part. Parts replaced under this warranty are covered for the duration of the original product warranty and become the property of Toro. Toro will make the final decision whether to repair any existing part or assembly or replace it. Toro may use remanufactured parts for warranty repairs.

Deep Cycle and Lithium-Ion Battery Warranty

Deep cycle and Lithium-Ion batteries have a specified total number of kilowatt-hours they can deliver during their lifetime. Operating, recharging, and maintenance techniques can extend or reduce total battery life. As the batteries in this product are consumed, the amount of useful work between charging intervals will slowly decrease until the battery is completely worn out. Replacement of worn out batteries, due to normal consumption, is the responsibility of the product owner. Note: (Lithium-Ion battery only): Pro-rated after 2 years. Refer to the battery warranty for additional information.

Maintenance is at Owner's Expense

Engine tune-up, lubrication, cleaning and polishing, replacement of filters, coolant, and completing recommended maintenance are some of the normal services Toro products require that are at the owner's expense.

General Conditions

Repair by an Authorized Toro Distributor or Dealer is your sole remedy under this warranty.

Neither The Toro Company nor Toro Warranty Company is liable for indirect, incidental or consequential damages in connection with the use of the Toro Products covered by this warranty, including any cost or expense of providing substitute equipment or service during reasonable periods of malfunction or non-use pending completion of repairs under this warranty. Except for the Emissions warranty referenced below, if applicable, there is no other express warranty. All implied warranties of merchantability and fitness for use are limited to the duration of this express warranty.

Some states do not allow exclusions of incidental or consequential damages, or limitations on how long an implied warranty lasts, so the above exclusions and limitations may not apply to you. This warranty gives you specific legal rights, and you may also have other rights which vary from state to state.

Note Regarding Emissions Warranty

The Emissions Control System on your Product may be covered by a separate warranty meeting requirements established by the U.S. Environmental Protection Agency (EPA) and/or the California Air Resources Board (CARB). The hour limitations set forth above do not apply to the Emissions Control System Warranty. Refer to the Engine Emission Control Warranty Statement supplied with your product or contained in the engine manufacturer's documentation.



Count on it.