



Topdresser 2500

Model No. 44507—200000001 and Up

Parts Catalog

Ordering Replacement Parts

To order replacement parts, please supply: the part number, the quantity, and the description of each part desired.

Understanding Reference Numbers

Each identified part in an illustration has a reference number. The reference number for a part also appears in the parts list, along with other information about the part.

This catalog uses two special reference number formats, one to indicate parts in a service assembly and another to indicate the quantity of a given part in an illustration.

Service Assembly Reference Numbers

Parts in service assemblies have reference numbers in the form **a:b**. The **a** represents the reference number of the entire service assembly and the **b** represents a sequential number unique to each part within the service assembly.

For example, a wheel assembly might be identified by reference number **6**, the tire by **6:1**, the valve by **6:2**, and the wheel by **6:3**. When you order the assembly identified by reference number **6**, you receive all parts identified by reference numbers **6:1**, **6:2**, and **6:3**. However, you may also order any part individually.

Reference numbers of this type appear in illustrations and in part lists.

Reference Numbers Indicating Quantity

In an illustration, if a reference number indicates more than one part, the reference number has the form **nX y**. The **n** represents the quantity of the part, the **X** is the multiplication symbol, and the **y** represents the reference number.

For example, in an illustration, the reference number **2X 37** means that two of the parts identified by reference number **37** are indicated.

Contents

Description	Page	Description	Page
Cradle Assembly	3	Hopper Assembly	11
Cradle and Trailer Assembly	4	Gate Slide and Brush Guard Assembly	12
Hydraulic Manifold Assembly	6	Chain, Sprocket and Guard Assembly	13
Hydraulics Installation Assembly	7	Brake Option Assembly	14
Slider Bed and Roller Assembly	8	Hydraulic Schematic	15
Gate Assembly	9	Electrical Schematic	16
Brush and Motors Assembly	10	Electrical Schematic – Brake Option	16

Accessories

Description	Model / Part No.	Description	Model / Part No.
Hydraulic Brake Kit	99-0154	Hydraulic Filter	86-3010
Mobil EAL 224H (5 gallon)	100-7674		
(or contact distributor)			

Part Description Abbreviations

Part descriptions in this catalog may include the following abbreviations.

Abbreviation	Meaning	Abbreviation	Meaning
AR	as required	INC	incorporated
ASM	assembly	LH	left hand
CARR	carriage	NI	nylon insert
DEG	degrees	PPH	Phillips pan head
FH	flat head	PTH	Phillips truss head
GA	gauge	PTO	power take off
HF	hex flange	RH	right hand
HH	hex head	SFH	slotted fillister head
HHF	hex head flange	SHH	slotted hex head
HLH	hex lag head	SQH	square head
HJ	hex jam	SHWH	slotted hex washer head
HOC	height-of-cut	SPH	slotted pan head
HS	hex socket	SRH	slotted round head
HSBH	hex socket button head	STD	standard
HSFH	hex socket flat head	TAP	self tapping
HSH	hex socket head	TTH	Torx truss head
HWH	hex washer head	WH	wing head
HWHTF	hex washer head thread forming		

3322-664

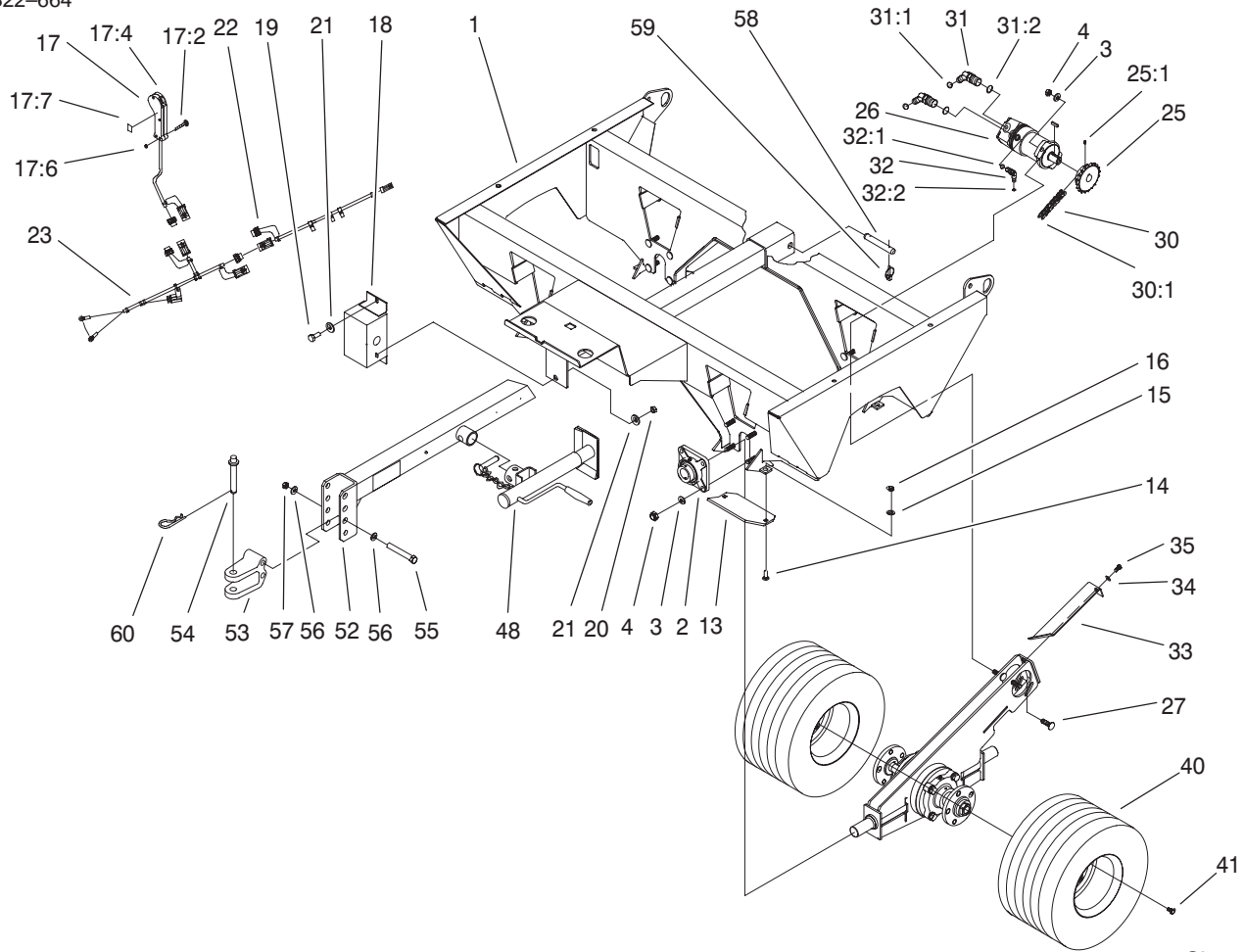

Sheet No.:3

Cradle and Trailer Assembly

Ref. No.	Part No.	Qty.	Description
1	100-1480-01	1	Frame-Trailer
2	100-1456	4	Bearing
3	3256-26	20	Washer-Flat
4	3296-23	20	Nut-Lock, NI
13	100-7678-01	4	Plate-Skid
14	3231-25	8	Screw-CARR
15	3256-25	8	Washer-Flat
16	3296-39	8	Nut-Lock, NI
17	100-7680	1	Control Handle ASM
17:2	100-7681	4	Screw-SRH
17:4	01-603-0760	1	Boot-Rubber
*17:5	01-603-0750	1	Switch-Pole, Single
17:6	3217-32	4	Nut-Hex
17:7	100-7682	2	Decal-On/Off
18	100-1410	1	Flow Divider-Charge Pump
19	325-5	2	Screw-HH
20	3296-45	2	Nut-Lock, NI
21	3256-6	4	Washer-Flat
22	99-0008	1	Harness - Wire, Trailer
22:1	100-4918	1	Diode
23	99-0198	1	Harness-Wire, Battery
23:1	110928	1	5amp Fuse
25	100-7691	2	Sprocket-Chain, Roller

Ref. No.	Part No.	Qty.	Description
25:1	3246-3	2	Screw-HS
26	100-1459	2	Motor-Hydraulic
*26:1	100-1466	1	Kit-Seal
26:2	5-7280	1	Key
27	100-7698	2	Bolt-Carriage
30	100-1472	2	Chain-Cradle, Roller
30:1	2710-16	1	Link-Chain
31	340-14	4	Fitting-Hydraulic 45°
31:1	237-65	1	O-Ring
31:2	237-80	1	O-Ring
32	340-103	2	Fitting
32:1	237-78	1	O-Ring
32:2	237-21	1	O-Ring
33	100-1452	2	Cover-Cradle, Top
34	3256-24	2	Washer-Flat
35	323-4	2	Screw-HH
40	99-0169	4	Wheel & Tire ASM
41	71-4450	20	Bolt-Lug
48	98-5016	1	Jack ASM
52	100-7686	1	Tongue ASM
53	47-3550	1	Hitch-Clevis
54	13-6200	1	Hitch-Pointed, Pin
55	327-23	2	Screw-HH
56	3256-7	4	Washer-Flat
57	3296-53	2	Nut-Lock NI
58	100-7694	2	Pin-Clevis

* Not Illustrated.

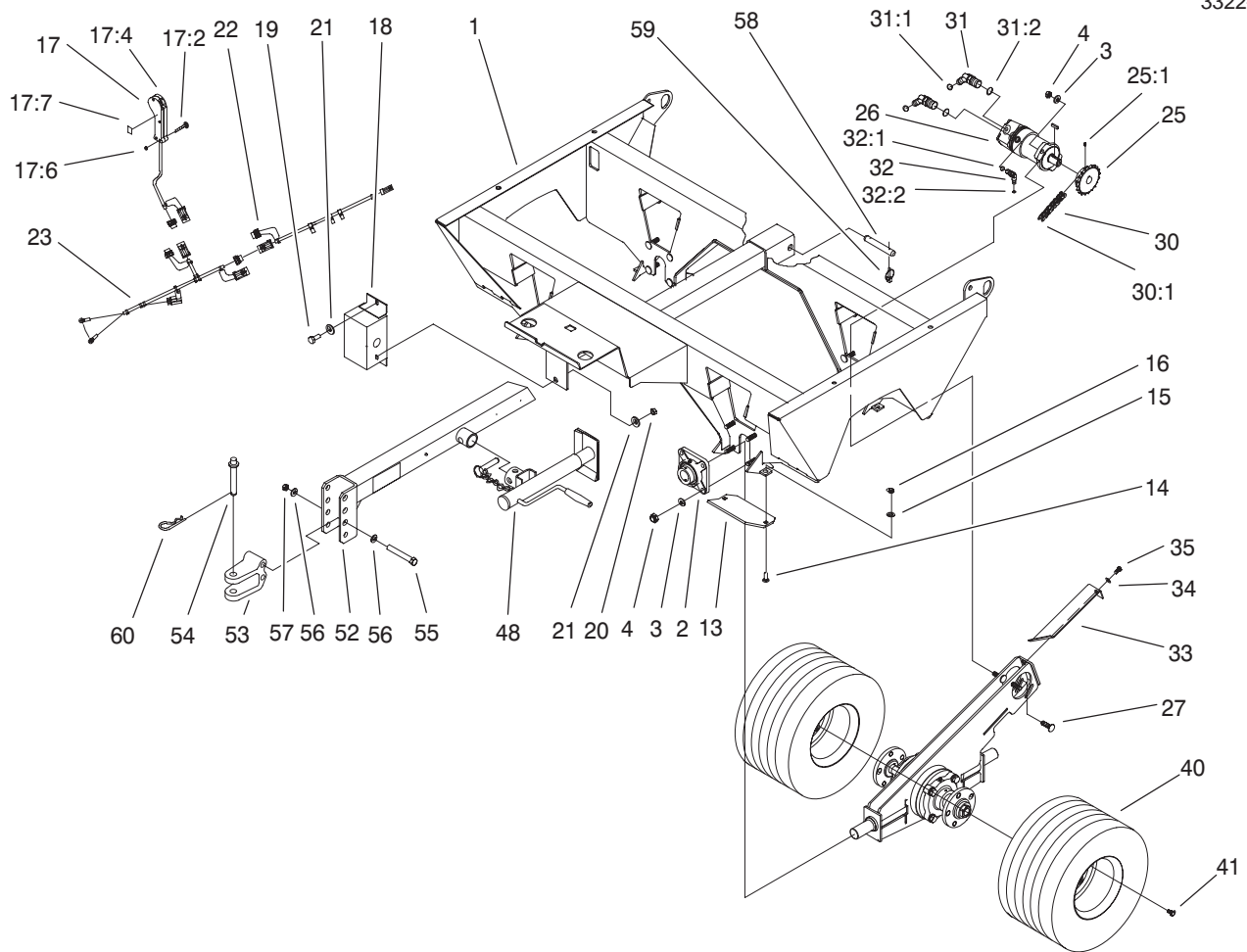

Sheet No.:3

Cradle and Trailer Assembly (Continued)

Ref. No.	Part No.	Qty.	Description
59	92-1298	4	Pin - Lynch
60	3290-468	1	Pin-Cotter, Hair

Ref. No.	Part No.	Qty.	Description

* Not Illustrated.

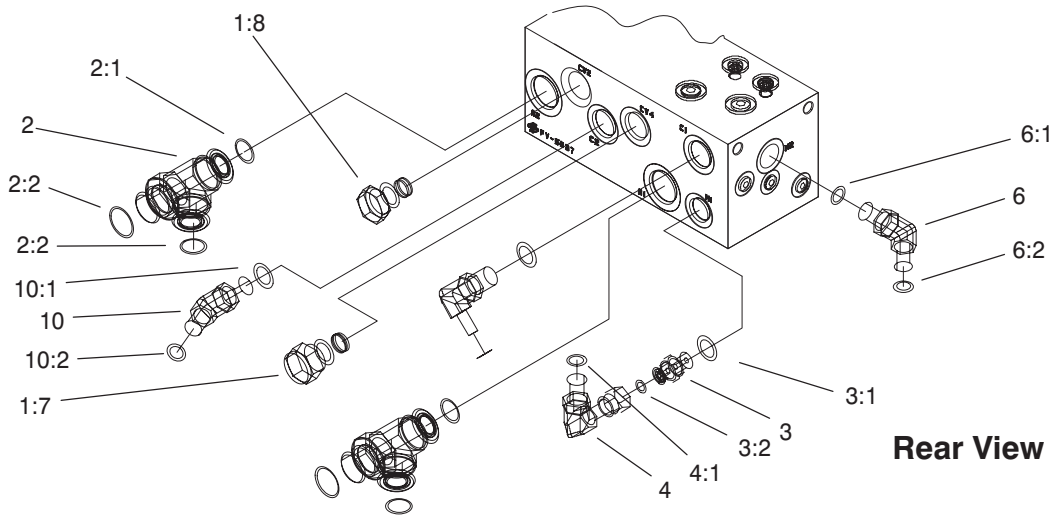

Rear View

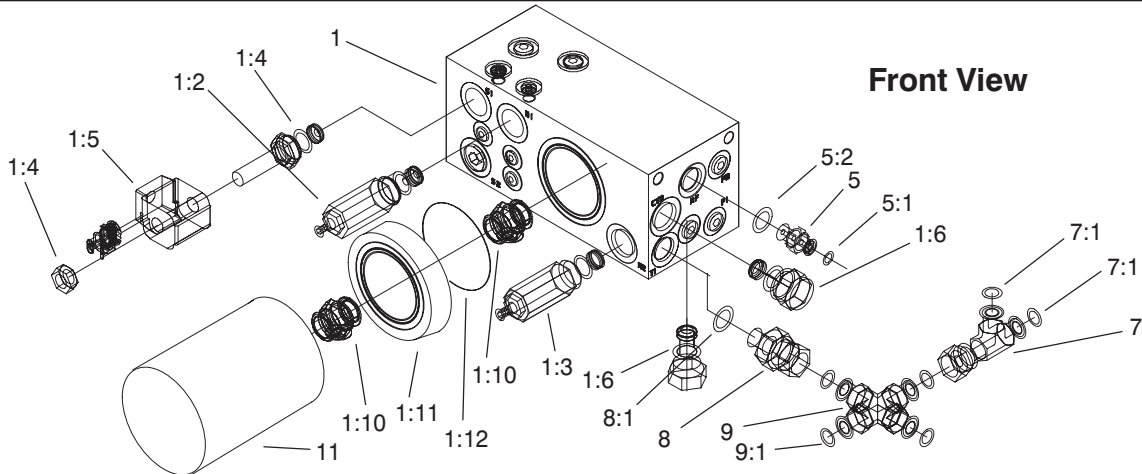

Front View

Sheet No.:4

Hydraulic Manifold Assembly

Ref. No.	Part No.	Qty.	Description
1	100-1460	1	Manifold-Hyd
1:2	97-3206	1	Valve-Relief
1:3	100-7717	1	Valve-Relief
1:4	100-7718	2	Valve-Solenoid
1:5	100-7720	2	Coil-Solenoid
1:6	100-7721	2	Valve-Check
1:7	100-7722	1	Valve-Check
1:8	100-7723	1	Valve-Check
1:10	104-2506	2	Adapter-Filter
1:11	104-2507	1	Adapter-Flow
1:12	104-2508	1	O-ring
2	340-148	2	Fitting
2:1	237-81	1	O-Ring
2:2	237-58	2	O-Ring
3	340-155	1	Fitting - Hyd
3:1	237-79	1	O-Ring
3:2	237-151	1	O-Ring
4	340-160	1	Fitting-Hyd, 90°
4:1	237-65	1	O-Ring
5	340-4	1	Adapter
5:1	237-30	1	O-Ring
5:2	237-79	1	O-Ring
6	340-153	1	Fitting-Hyd
6:1	237-79	1	O-Ring
6:2	237-151	1	O-Ring
7	340-104	1	T Fitting

Ref. No.	Part No.	Qty.	Description
7:1	237-151	2	O-Ring
8	100-7671	1	Adapter-Hyd.
8:1	237-79	1	O-Ring
9	100-7670	1	Adapter-Hyd.
9:1	237-151	4	O-Ring
10	340-17	2	Adapter
10:1	237-65	1	O-Ring
10:2	237-80	1	O-Ring
11	86-3010	1	Filter-Oil, Transmission

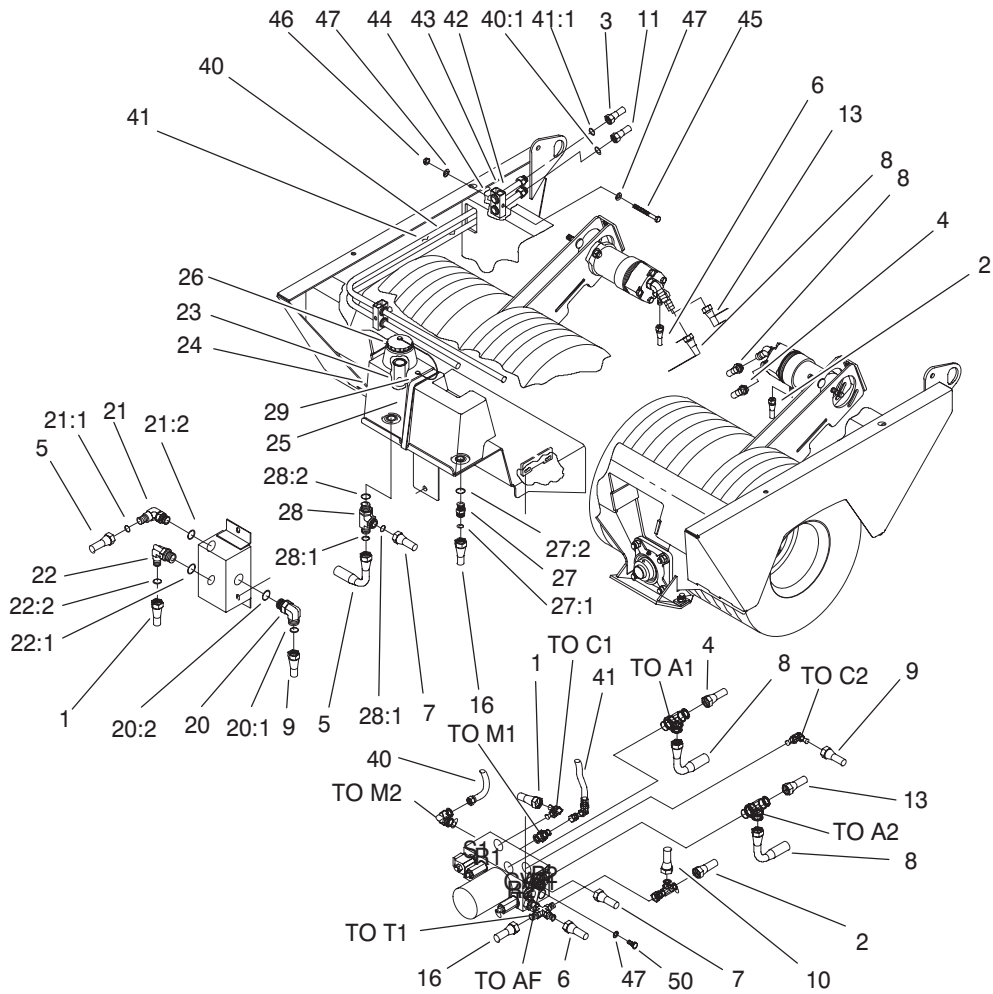

Sheet No.:5

Hydraulics Installation Assembly

Ref. No.	Part No.	Qty.	Description
1	100-7655	1	Hydraulic Hose ASM
2	100-7664	1	Hydraulic Hose ASM
3	100-7653	1	Hydraulic Hose ASM
4	100-7662	1	Hydraulic Hose ASM
5	100-7657	1	Hydraulic Hose ASM
6	100-7663	1	Hydraulic Hose ASM
7	100-7658	1	Hydraulic Hose ASM
8	100-7661	2	Hydraulic Hose ASM
9	100-7656	1	Hydraulic Hose ASM
10	100-7669	1	Hose ASM
11	100-7654	1	Hydraulic Hose ASM
13	100-7672	1	Hydraulic Hose ASM
16	100-7668	1	Hose ASM
20	340-142	1	Elbow-90°
20:1	237-58	1	O-Ring
20:2	237-81	1	O-Ring
21	340-17	1	Adapter
21:1	237-65	1	O-Ring
21:2	237-80	1	O-Ring
22	340-139	1	Fitting-90°
22:1	237-81	1	O-Ring
22:2	237-65	1	O-Ring
23	92-1705	1	Filter-Screen
24	94-4700	1	Tank - Hydraulic
25	100-7693	1	Clamp-Tank
26	93-4365	1	Cap-Oil

Ref. No.	Part No.	Qty.	Description
27	340-4	1	Adapter
27:1	237-30	1	O-Ring
27:2	237-79	1	O-Ring
28	340-22	1	Adapter
28:1	237-65	2	O-Ring
28:2	237-80	1	O-Ring
29	3290-126	1	Screw
40	100-7666	1	Tube-Hyd., Conv.
40:1	237-80	1	O-Ring
41	100-7667	1	Tube-Hyd. Brush
41:1	237-80	1	O-Ring
42	100-7696	2	Clamp-Tube
43	100-7697	4	Bushing-Split
44	100-7684	2	Spacer-Clamp
45	323-57	2	Screw-HH
46	3296-39	2	Nut-Lock, NI
47	3256-24	8	Washer-Flat
50	323-5	4	Screw-HH
*99	100-7674	1	Oil-Hyd 5 Gal.
*99:1	99-0010	1	Decal-Hydraulic Fluid

* Not Illustrated.

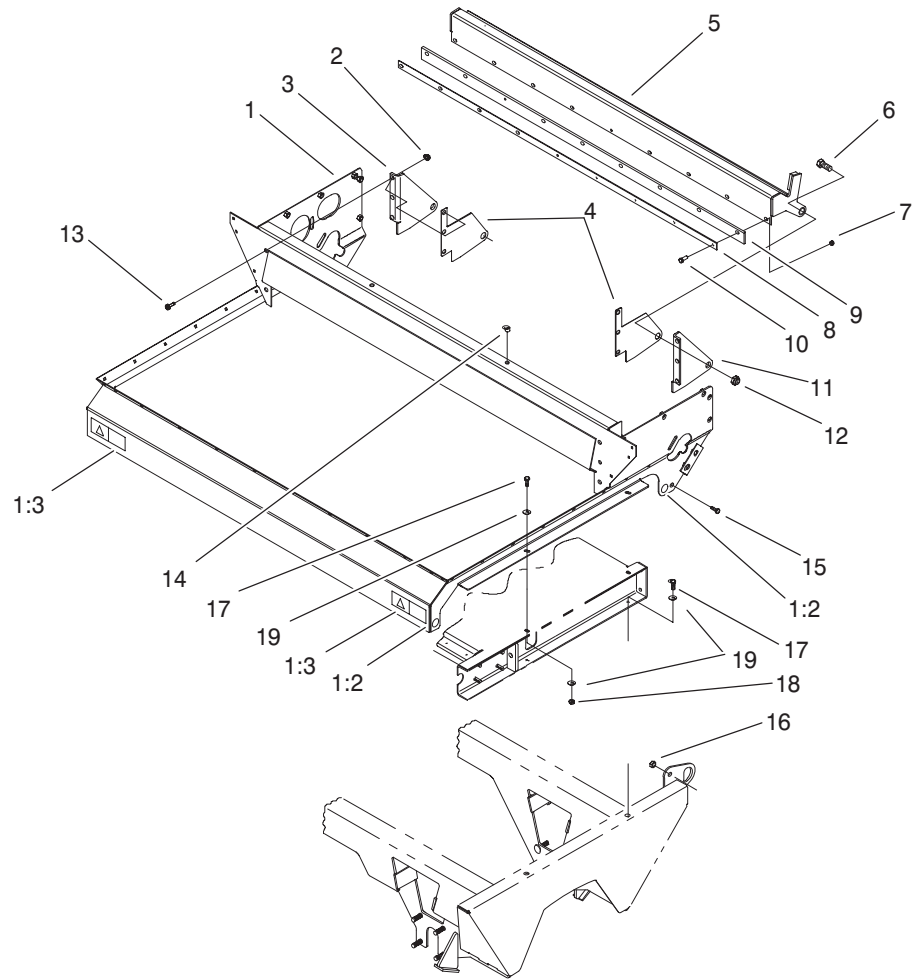

Sheet No.:7

Gate Assembly

Ref. No.	Part No.	Qty.	Description	Ref. No.	Part No.	Qty.	Description
1	100-1435	1	Hopper Frame ASM				
1:2	58-6520	4	Decal-Grease				
1:3	93-9092	2	Decal - Warning				
2	32128-37	6	Nut-Hex Flange				
3	99-0079-01	1	Bracket-Gate Pivot, RH				
4	99-0117	2	Wareplate-Gate				
5	99-0068-01	1	Gate ASM				
6	328-24	2	Screw-HH				
7	3296-29	9	Nut-Lock, NI				
8	99-0089-01	1	Plate-Backing				
9	99-0074	1	Seal-Gate				
10	322-5	9	Screw-HH				
11	99-0078-01	1	Bracket-Gate Pivot, LH				
12	3296-51	2	Nut-Lock NI				
13	324-4	6	Screw-HH				
14	32148-9	2	Nut-Insert				
15	325-2	2	Screw-HH				
16	3296-45	2	Nut-Lock, NI				
17	323-6	8	Screw-HH				
18	3296-39	4	Nut-Lock, NI				
19	3256-24	12	Washer-Flat				

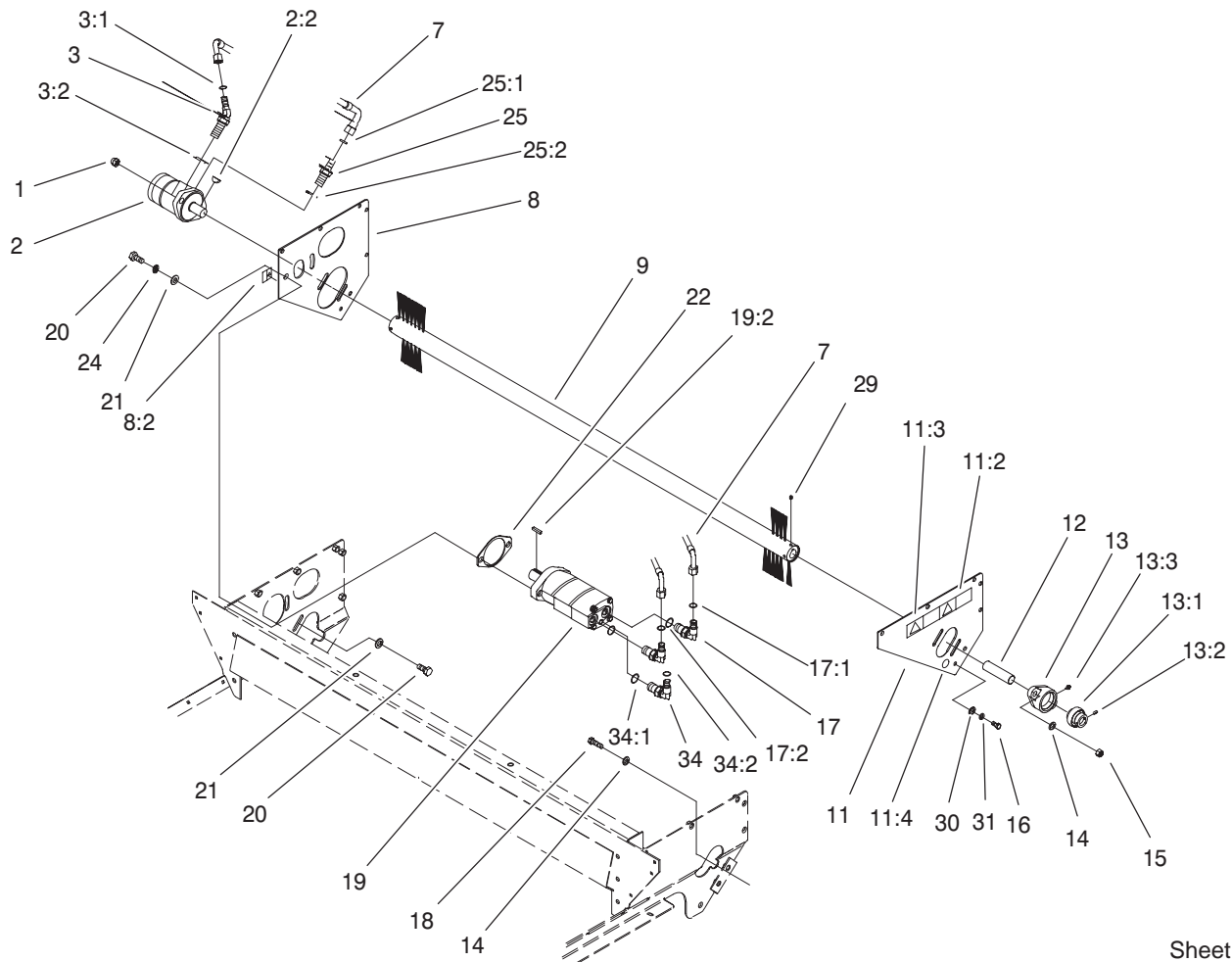

Sheet No.:8

Brush and Motors Assembly

Ref. No.	Part No.	Qty.	Description
1	3296-45	2	Nut-Lock, NI
2	99-0156	1	Motor-Hydraulic
*2:1	100-1446	1	Kit-Seal
2:2	3257-43	1	Key-Woodruff
3	340-89	1	Fitting-45°
3:1	237-30	1	O-Ring
3:2	237-80	1	O-Ring
7	99-0177	1	Hose-Hyd
8	100-1431	1	RH Motor Brace ASM
8:2	98-3114	1	Decal - Warning, Ce
9	99-0162	1	Brush
11	100-1430	1	LH Motor Brace ASM
11:2	99-0015	1	Decal-Danger
11:3	93-9867	1	Decal - No Riders
11:4	58-6520	1	Decal-Grease
12	99-0041	1	Shaft - Brush
13	99-0160	1	Bearing
13:1	251-246	1	Collar w/Set Screws
13:2	3245-35	1	Screw-HS
13:3	302-2	1	Fitting-Grease
14	3256-25	4	Washer-Flat
15	3296-48	2	Nut-Lock NI
16	323-4	4	Screw-HH
17	340-105	2	Fitting-Hyd., 90°
17:1	237-30	1	O-Ring
17:2	237-80	1	O-Ring

Ref. No.	Part No.	Qty.	Description
18	324-6	2	Screw-HH
19	99-0155	1	Hydraulic Motor Conveyor ASM
*19:1	100-1447	1	Kit-Seal
19:2	10-7070	1	Key-Square
20	325-6	4	Screw-HH
21	3256-26	4	Washer-Flat
22	99-0116	1	Plate-Spacer
24	3253-7	2	Washer-Lock/Sp
25	340-6	1	Fitting-Straight
25:1	237-30	1	O-Ring
25:2	237-80	1	O-Ring
29	3246-3	4	Screw-HS
30	3256-24	4	Washer-Flat
31	3253-21	4	Washer-Lock
34	100-7695	1	Adapter-Hyd.
34:1	237-78	1	O-Ring
34:2	237-21	1	O-Ring
99	3290-379	4	Tie-Cable

* Not illustrated

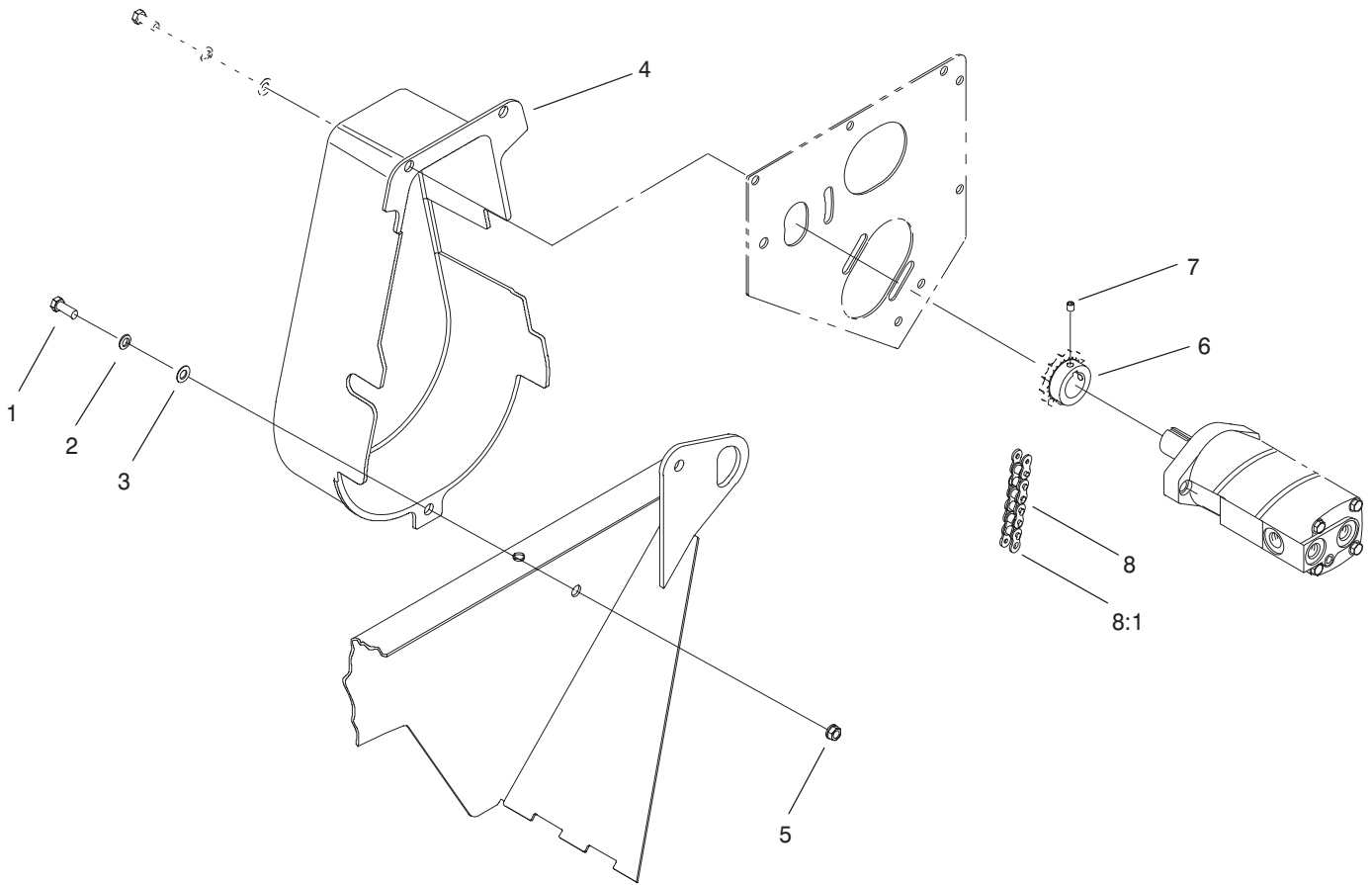

Sheet No.:11

Chain, Sprocket and Guard Assembly

Ref. No.	Part No.	Qty.	Description
1	323-6	3	Screw-HH
2	3253-5	3	Washer-Lock/Sp
3	3256-24	3	Washer-Flat
4	99-0171	1	Guard-Chain & Sprockets
5	3296-39	1	Nut-Lock, NI
6	99-0165-03	1	Sproket-Drive
7	3246-3	2	Screw-HS
8	99-0164	1	Chain-Roller
8:1	2710-16	1	Link-Chain

Ref. No.	Part No.	Qty.	Description

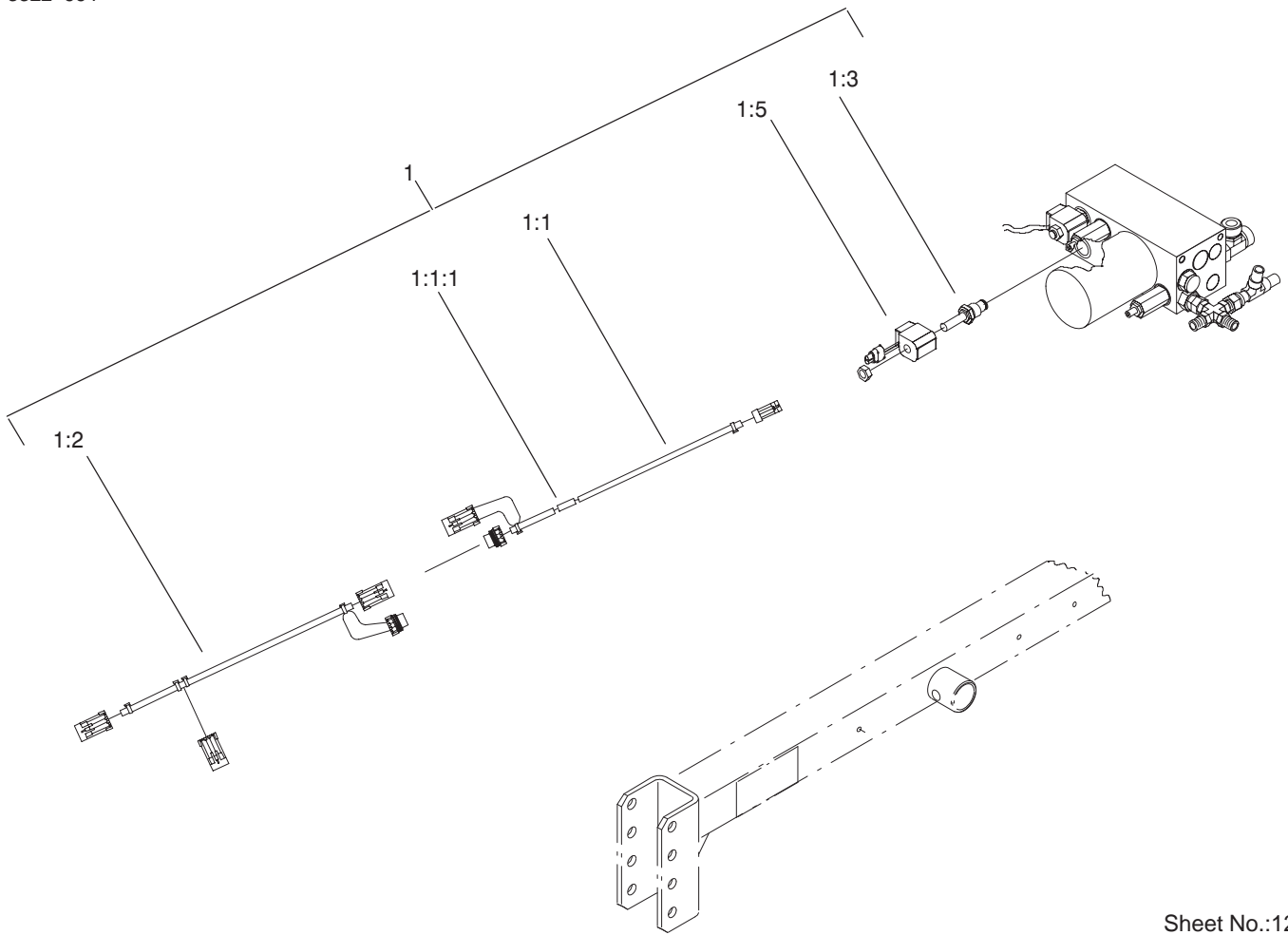

Sheet No.:12

Brake Option Assembly

Ref. No.	Part No.	Qty.	Description
1	99-0154	1	Kit-Brake, 2500
1:1	99-0197	1	Harness-Wire, Brake Solenoid
1:1:1	100-4918	1	Diode
1:2	99-0196	1	Harness-Wire
1:3	100-7718	1	Valve-Solenoid
1:5	100-7720	1	Coil-solenoid

Ref. No.	Part No.	Qty.	Description

Hydraulic Schematic

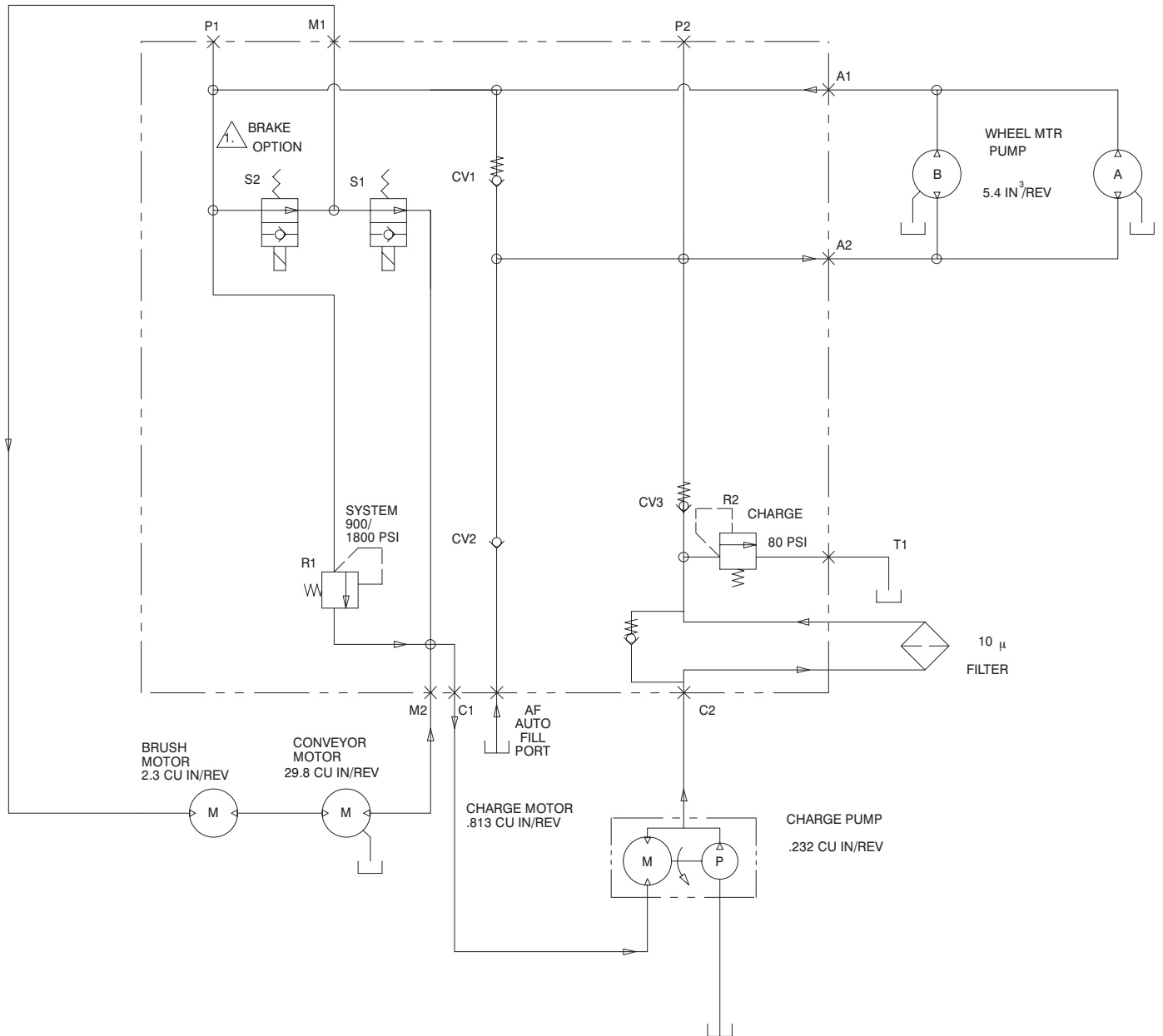

Electrical Schematic

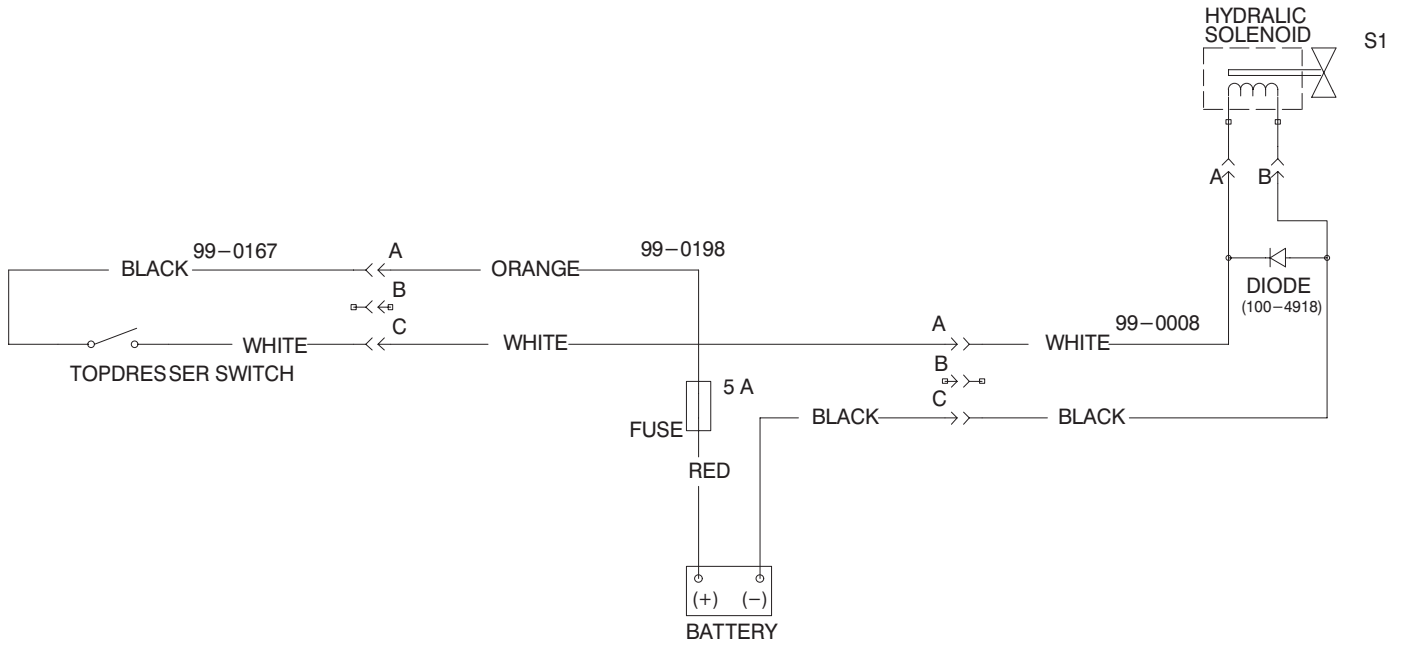

Electrical Schematic – Brake Option

