



Count on it.

Parts Catalog

11-Blade EdgeSeries DPA Cutting Unit

Greensmaster® 3300 or 3400 Series Traction Unit

Model No. 04653—Serial No. 403460001 and Up



Ordering Replacement Parts

To order replacement parts, please supply the part number, the quantity, and the description of each part desired.

Understanding Reference Numbers

Each identified part in an illustration has a reference number. The reference number for a part also appears in the parts list, along with other information about the part.

This catalog uses two special reference number formats, one to indicate parts in a service assembly and another to indicate the quantity of a given part in an illustration.

Service Assembly Reference Numbers

Parts in service assemblies have reference numbers in the form a:b. The a represents the reference number of the entire service assembly and the b represents a sequential number unique to each part within the service assembly.

For example, a wheel assembly might be identified by reference number 6, the tire by 6:1, the valve by 6:2, and the wheel by 6:3. When you order the assembly identified by reference number 6, you receive all parts identified by reference numbers 6:1, 6:2, and 6:3. However, you may also order any part individually. Reference numbers of this type appear in illustration and in parts lists.

Reference Numbers Indicating Quantity

In an illustration, if a reference number indicates more than one part, the reference number has the form nX y. The n represents the quantity of the part, the X is the multiplication symbol, and the y represents the reference number.

For example, in an illustration, the reference number 2X 37 means that two of the parts identified by reference number 37 are indicated.

Contents

Frame Assembly.....	4
Reel Assembly.....	5
Roller Assembly.....	6
Rear Full Roller Assembly No. 119-4093.....	7
Roller Seal Rebuild Kit Assembly No. 107-1594.....	8
Pitch Arm and Weight Assembly.....	9
Attachments and Accessories.....	10

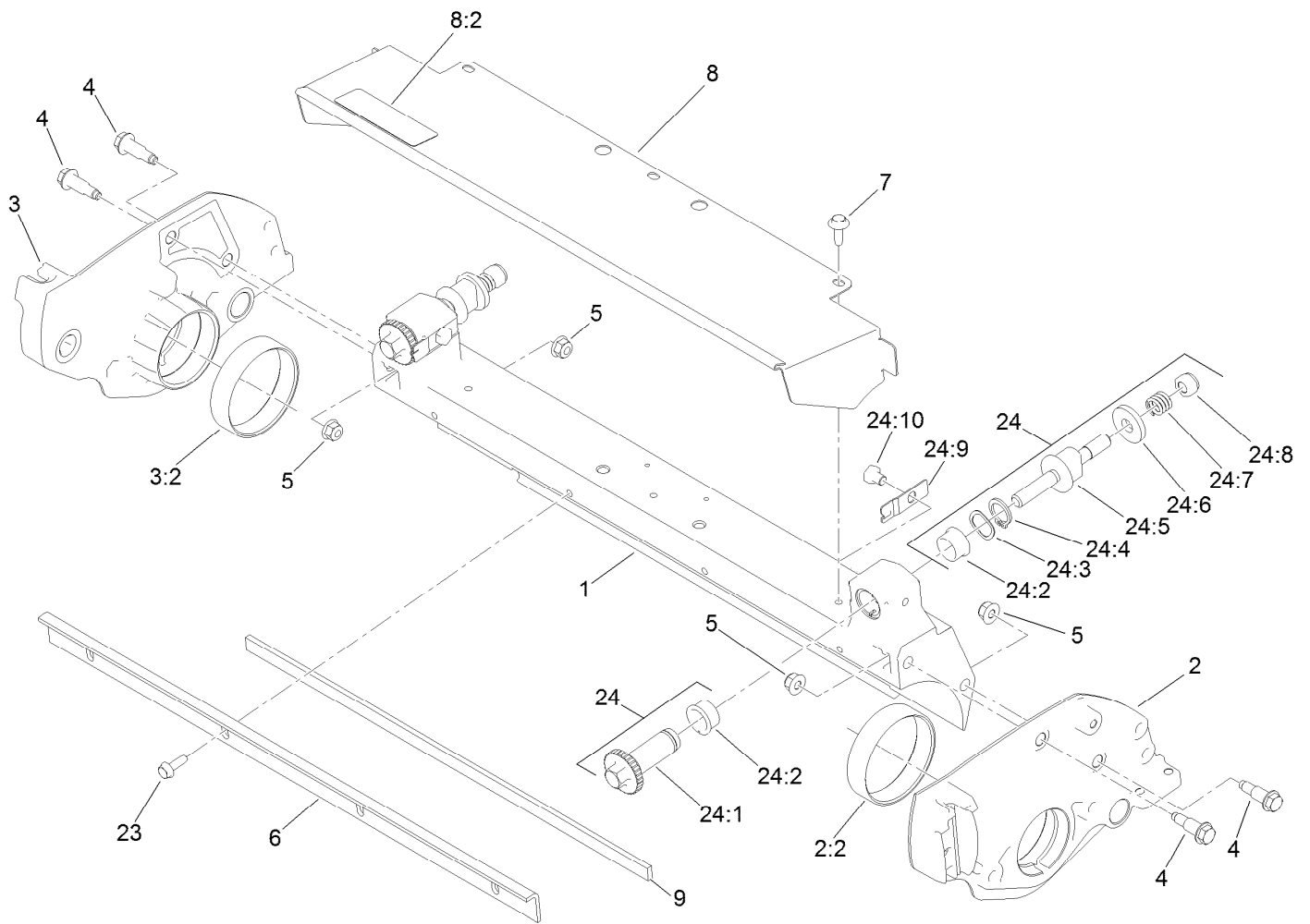

Frame Assembly

Ref.	Part Number	Qty.	Description	Ref.	Part Number	Qty.	Description
1	119-9303	1	Crossmember	23	131-6150	4	Screw-HWHTF
2	119-4005	1	LH Sideplate ASM	24	121-2637	1	DPA Adjusters MVP Kit
2:2	117-6619	1	Bushing	24:1	106-5363	2	Shaft-Adjuster
3	119-4007	1	RH Sideplate ASM	24:2	106-5344	4	Bushing-Flange, Keyed
3:2	117-6619	1	Bushing	24:3	119-4164	2	Washer-Wave
4	115-7042	4	Bolt-Shoulder, Flange	24:4	32120-93	2	Ring-Retaining
5	119-4041	4	Nut-HF	24:5	115-7039	2	Screw-Adjuster, Bedbar
6	115-3303-03	1	Bar-Cutoff	24:6	119-4155	2	Washer-Hardened
7	119-4012	3	Screw-HWHTF	24:7	119-4156	2	Spring-Compression
8	119-4095	1	Grass Shield ASM	24:8	119-4039	2	Nut-Hex, NI
8:2	137-9706	1	Decal-Warning	24:9	99-2097	2	Detent
9	106-2619	1	Strip-Seal	24:10	119-4067	2	Screw-HH

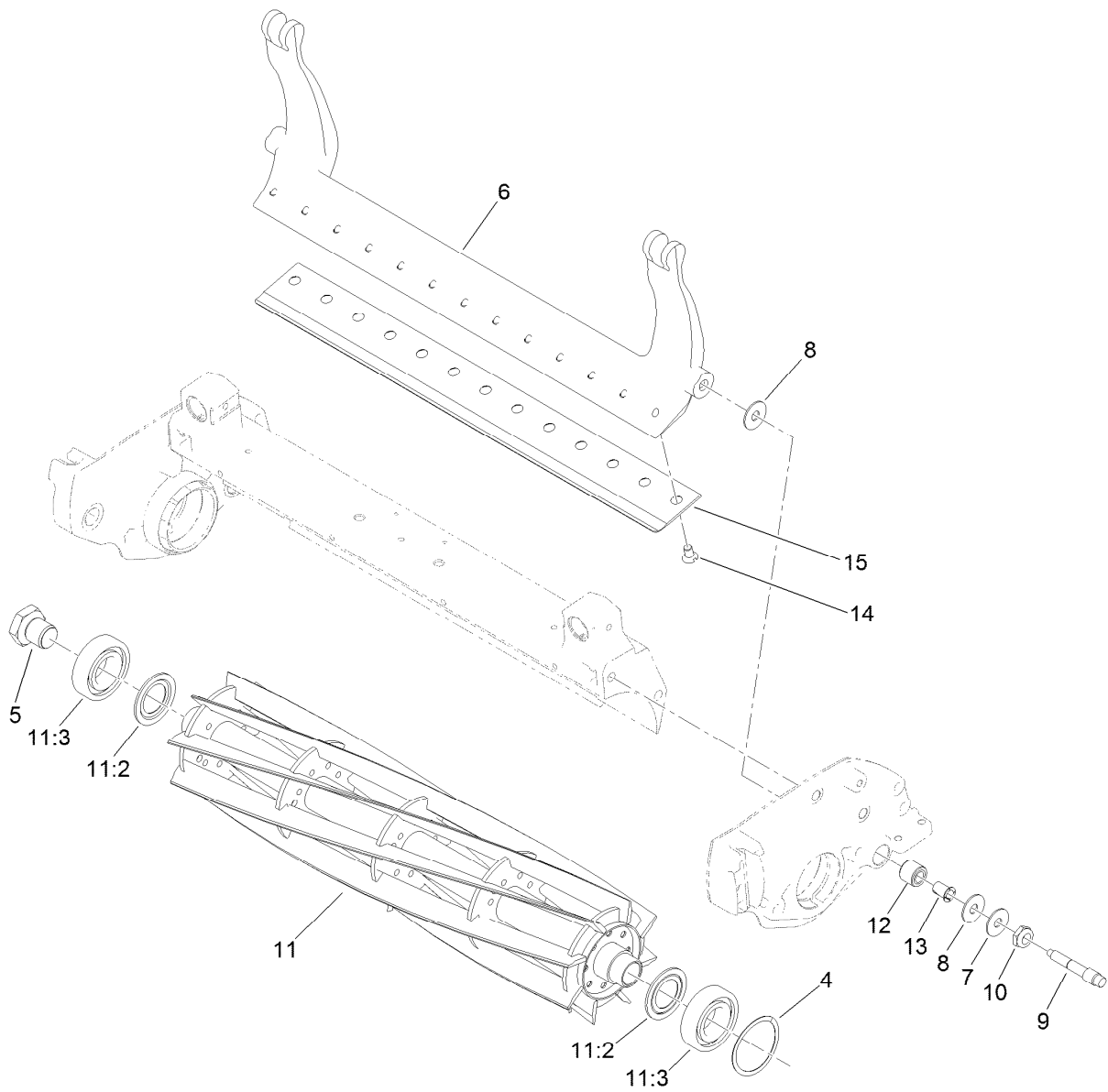

Reel Assembly

Ref.	Part Number	Qty.	Description	Ref.	Part Number	Qty.	Description
4	115-5258	1	Spring-Wire, Flat	13	52-2890	2	Bushing-Nylon
5	115-7263	1	Screw-Lock, Bearing	14	119-4151	13	Screw-Bedknife
6	106-2648-01	1	Bedbar	15	108-4302	1	Bedknife-Tournament, Extended ●
7	119-4150	2	Washer-Flat	15	108-4303	1	Bedknife-Microcut, Extended ●
8	52-2900	4	Washer-Plastic	15	115-1880	1	Bedknife-Edgemax, Microcut
9	117-9493	2	Bolt-Bedbar	15	115-1881	1	Bedknife-Edgemax, Tournament ●
10	119-4154	2	Nut-Lock, NI	15	63-8610	1	Bedknife-Fairway ●
11	137-8511	1	21 Inch 8 Blade Low Drag Reel ASM ●	15	93-4262	1	Bedknife-Microcut ●
11	137-8512	1	21 Inch 11 Blade Low Drag Reel ASM	15	93-4263	1	Bedknife-Tournament Cut ●
11	137-8513	1	21 Inch 14 Blade Low Drag Reel ASM ●	15	93-4264	1	Bedknife-Low Cut ●
11:2	115-3299	2	Seal-Flocked	15	94-6392	1	Bedknife-Highcut ●
11:3	115-3296	2	Bearing-Sealed				
12	119-4153	2	Rubber Bushing ASM				

● Optional Equipment

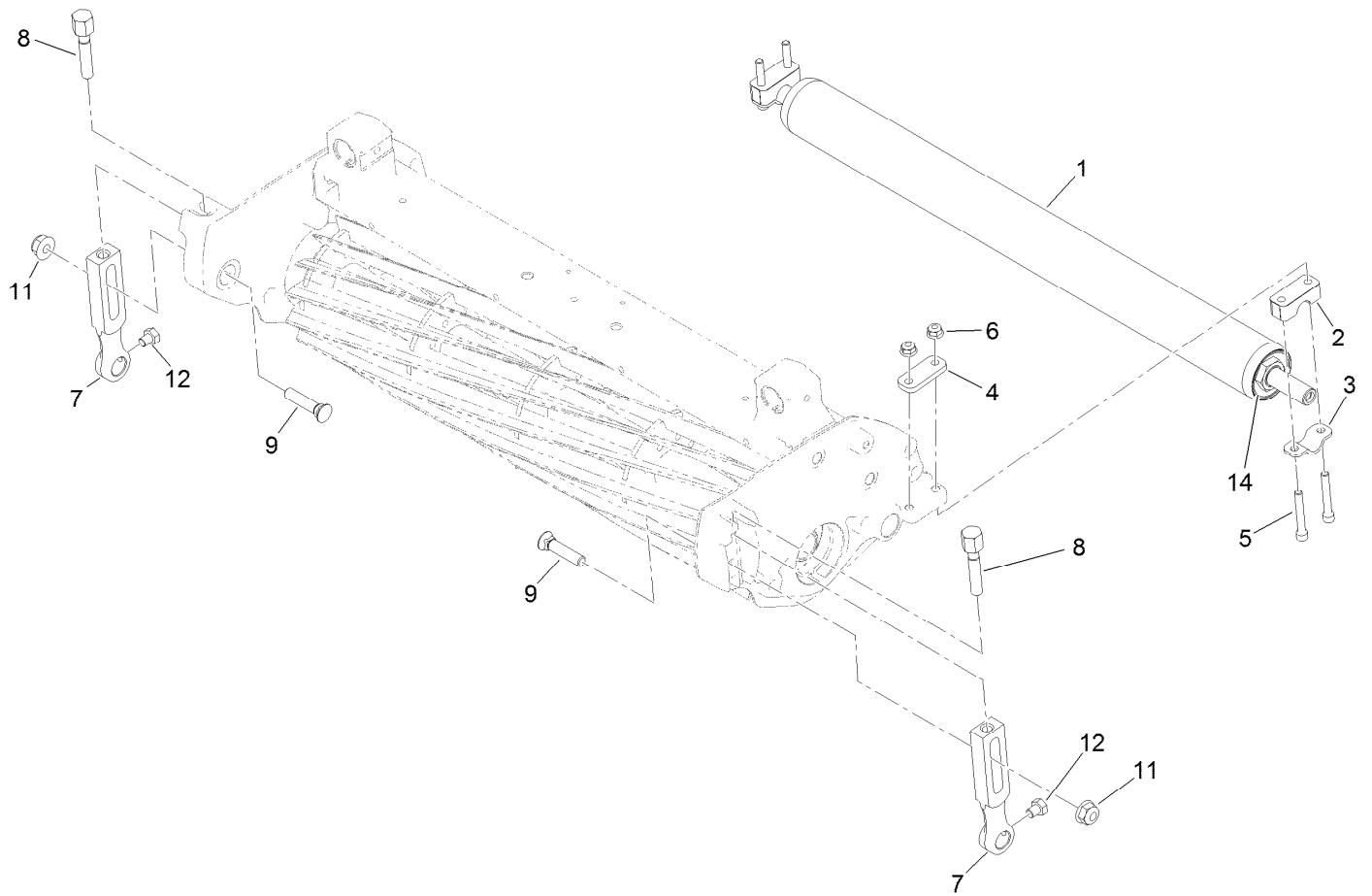

Roller Assembly

<i>Ref.</i>	<i>Part Number</i>	<i>Qty.</i>	<i>Description</i>
1	119-4093	1	Rear Full Roller ASM
2	119-4166	2	Spacer-Height, Roller
3	119-4157	2	Retainer-Shaft
4	119-4165	2	Shim-Height, Roller
5	119-4035	4	Screw-HSH
6	119-4040	4	Nut-Flange, NI
7	115-7041	2	Arm-HOC
8	110-7352	2	Screw-HOC
9	99-3773	2	Bolt-Plow
11	133-7570	2	Nut-Flange, NI
12	119-4067	2	Screw-HH
14	107-1594	1	Roller Seal Rebuild Kit ●

● Optional Equipment

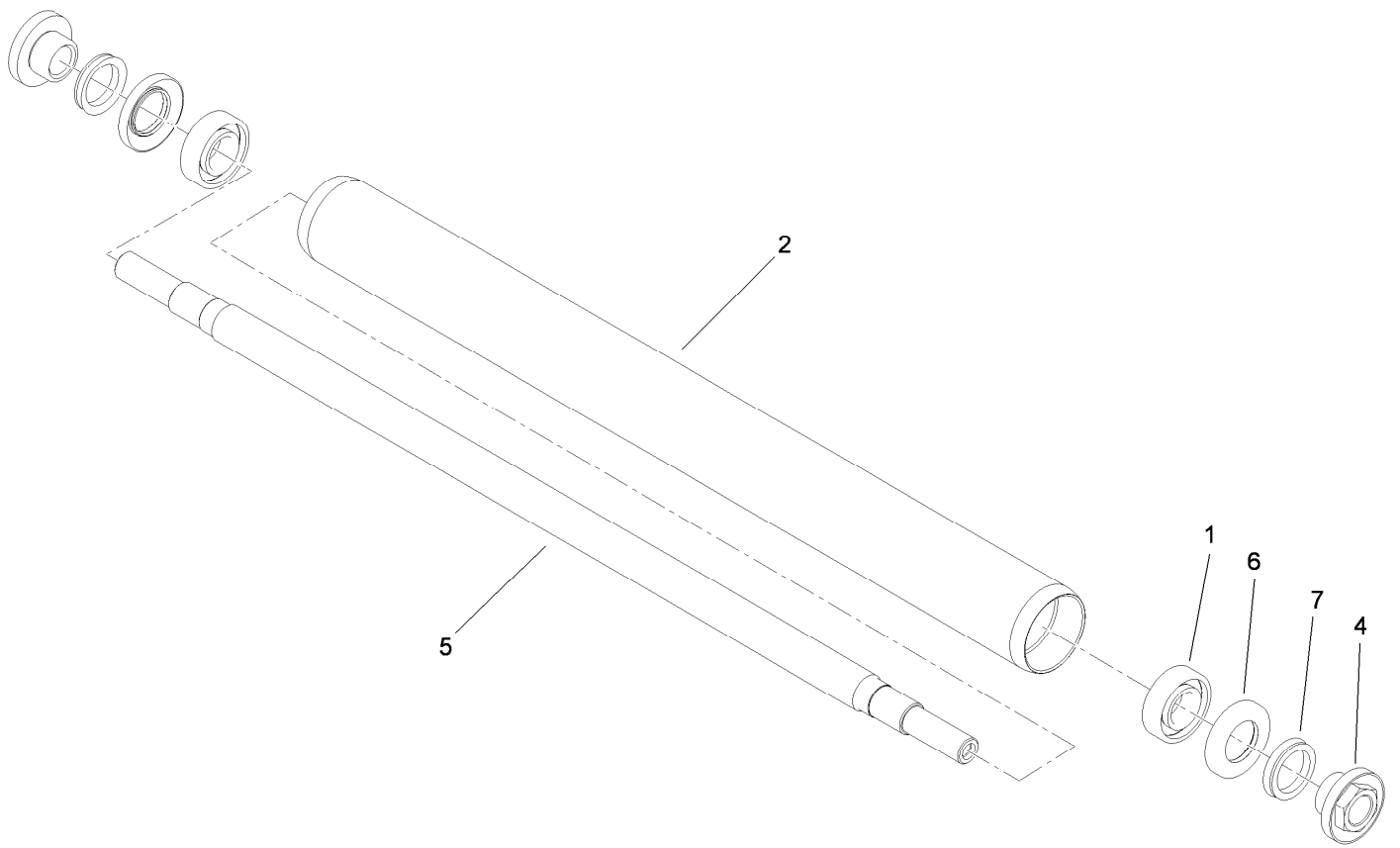

Rear Full Roller Assembly No. 119-4093

<i>Ref.</i>	<i>Part Number</i>	<i>Qty.</i>	<i>Description</i>
1	251-347	2	Bearing-Ball
2	119-4092	1	Roller Tube ASM
4	108-3151	2	Nut-Lock, Bearing
5	119-4090	1	Shaft-Roller
6	106-6941	2	Seal
7	106-6942	2	V-Ring

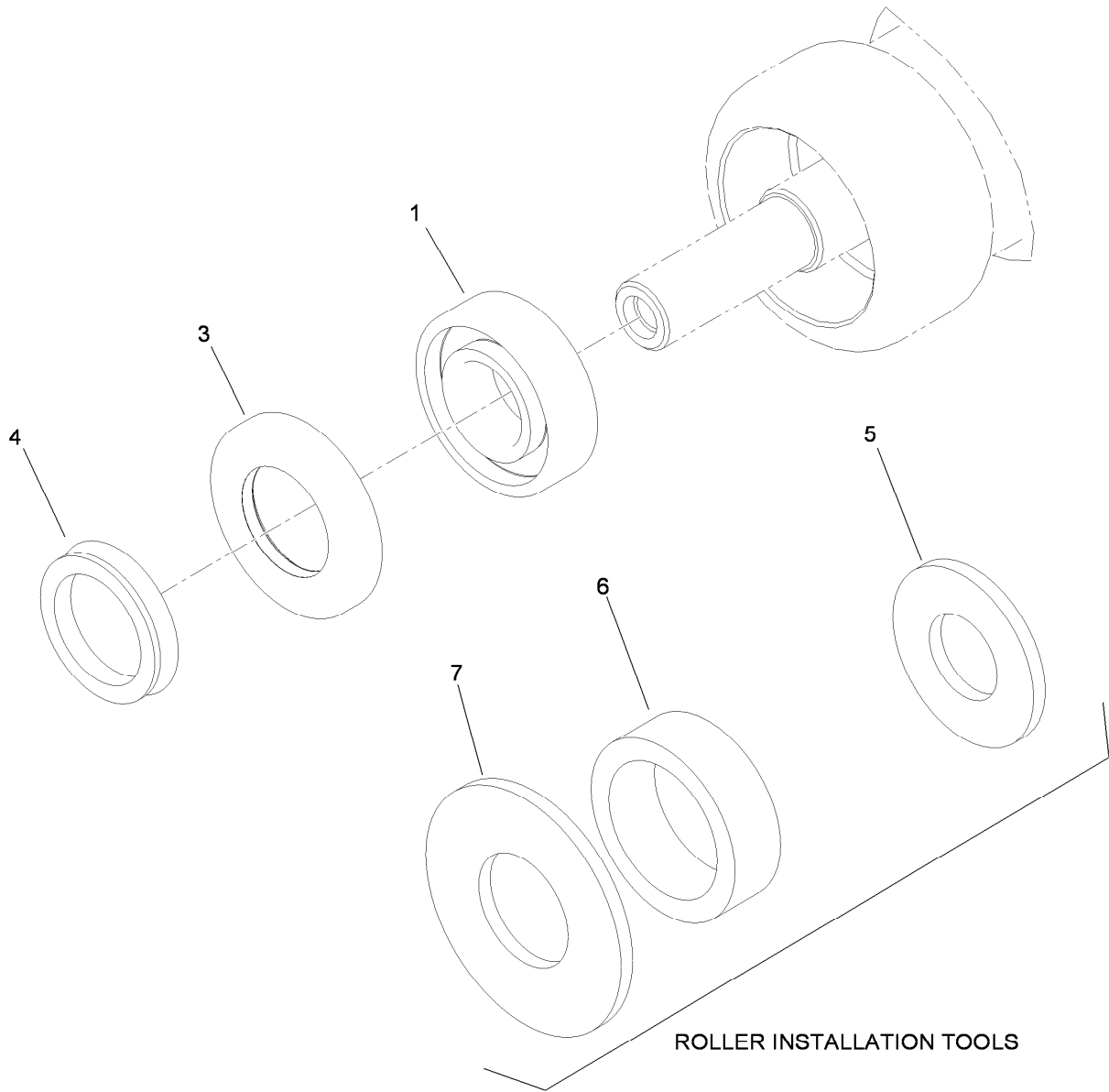

Roller Seal Rebuild Kit Assembly No. 107-1594

<i>Ref.</i>	<i>Part Number</i>	<i>Qty.</i>	<i>Description</i>
1	251-347	2	Bearing-Ball
3	106-6941	2	Seal
4	106-6942	2	V-Ring
5	107-8133	2	Washer-Flat
6	107-3505	2	Spacer-Tool, Roller
7	104-6126	2	Washer-Flat

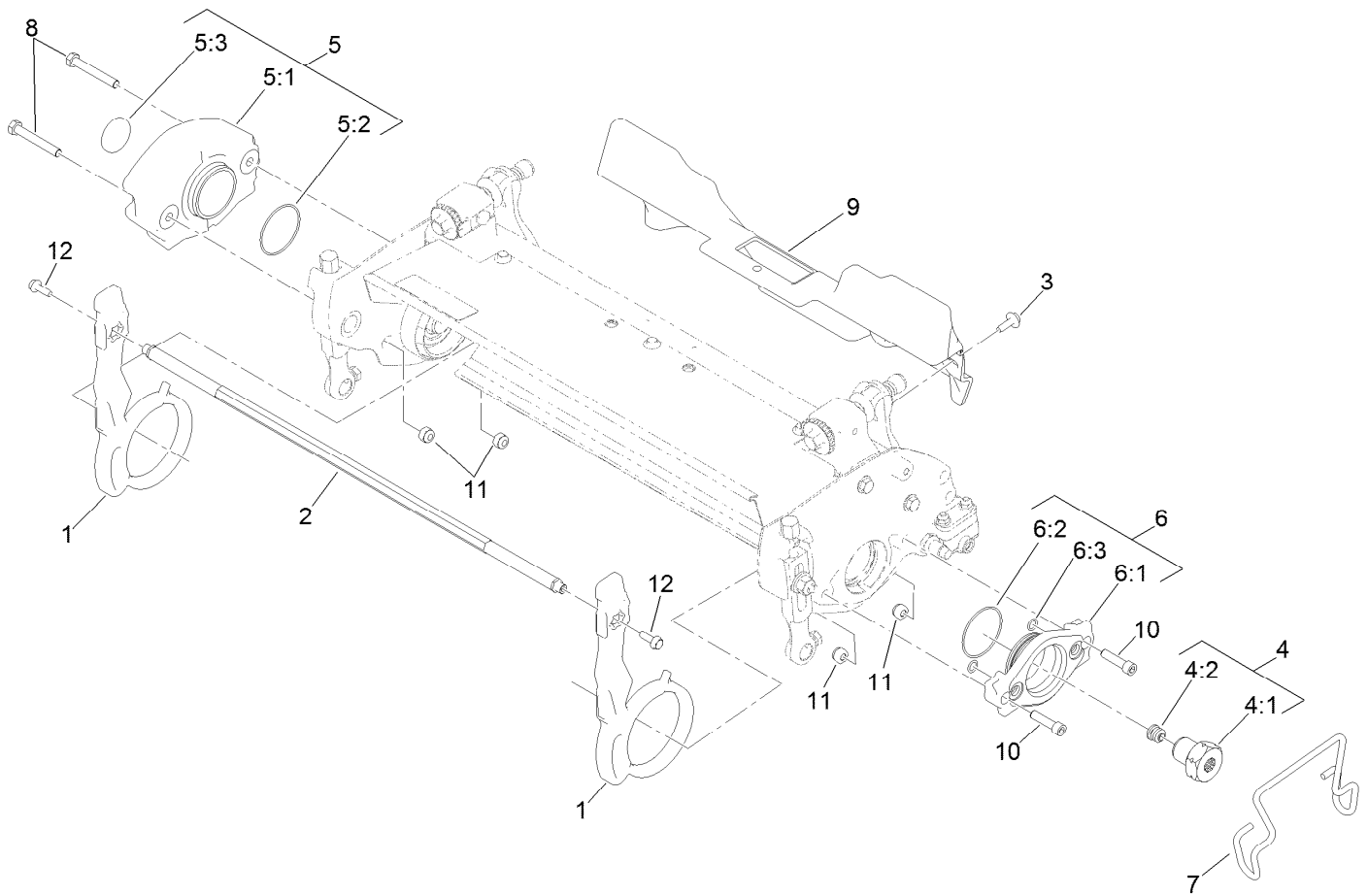

Pitch Arm and Weight Assembly

Ref.	Part Number	Qty.	Description	Ref.	Part Number	Qty.	Description
1	119-9307-01	2	Arm-Pitch	6	115-5227	1	Motor Adapter ASM
2	117-9456	1	Crosslink	6:1	115-3294	1	Adaptor-Motor
3	119-4012	4	Screw-HWHTF	6:2	360-0398	1	O-Ring
4	120-3221	1	LH Reel Nut ASM	6:3	237-22	2	O-Ring
4:1		1	Nut-Reel, Splined (LH) ●	7	117-6706	1	Clamp-Motor
4:2	120-3220	1	Plug-Plastic	8	322-11	2	Screw-HH
5	115-3340	1	Weight ASM	9	117-6849	1	Shield-Spring
5:1		1	Weight-Reel ●	10	3274-18	2	Screw-HSH
5:2	360-0398	1	O-Ring	11	119-4038	4	Nut-Hex
5:3	121-4609	1	Plug-Expansion	12	131-6150	2	Screw-HWHTF

● Not serviced separately

Attachments and Accessories

For 04653 11-Blade EdgeSeries DPA Cutting Unit Greensmaster 3300 or 3400 Series Traction Unit

Product Name	Model/Part
Turf Evaluator	04399
Split Full Front Roller	04249
Split Narrow Wiehle Roller	04250
Narrow Wiehle Roller (Qty 1)	04255
Wide Wiehle Roller (Qty 1)	04256
Front Full Smooth Roller (Qty 1)	04257
Extended Narrow Wiehle Roller (Qty 1)	04258
Paspalum Wiehle Roller (Qty 1).....	04267
Full Roller Kit (Set of 3).....	04625
Narrow Wiehle Roller Kit (Set of 3)	04626
Wide Wiehle Roller Kit (Set of 3).....	04627
Narrow Wiehle Steel Roller Asm.....	107-3510
Wide Wiehle Steel Roller Asm	107-3514
Narrow Wiehle Roller Kit.....	115-7360
Wide Wiehle Roller Kit	115-7386
Front Full Smooth Roller Kit.....	115-7388
Extended Wiehle Roller Kit	121-4675
Paspalum Wiehle Roller	121-9535
Cast Iron Wiehle Roller (Qty 1)	71-1550
Height-of-Cut Bar.....	94-9010
Front Brush for Narrow Wiehle Roller (Qty 1).....	115-7377
Front Brush for Wide Wiehle Roller (Qty 1)	115-7378
Front Brush for Full Roller (Qty 1)	115-7379
Front Comb for Narrow Wiehle Roller (Qty 1).....	115-7380
Front Comb for Wide Wiehle Roller (Qty 1).....	115-7381
Front Comb for Full Roller (Qty 1)	115-7382
Front Scraper for Narrow Wiehle Roller (Qty 1).....	125-3503
Front Scraper for Wide Wiehle Roller (Qty 1)	125-3504
Front Scraper for Full Roller (Qty 1)	125-3505
Steel Roller Asm	107-3509
Steel Rear Full Roller (Qty 1)	120-9595
Rear Roller Scraper Kit (Set of 3).....	04646
Rear Roller Scraper (Qty 1)	121-2260
Steel Roller (Qty 1)	04628
Dampening Roller Kit.....	04629
Roller Scraper Kit.....	107-9561
Rear Roller Brush, Greensmaster 3250-D, TriFlex 3300, and 3400 Series DPA Cutting Units with Universal Groomer	04650
RRB Adapter Kit	132-0723
Universal Groomer Drive Kit	04648
21in Soft Grooming Brush.....	04270
21in Stiff Grooming Brush.....	04271
21in Twin Tip Groomer Reel	04802
21in Soft Grooming Brush Kit.....	127-1547
21in Stiff Grooming Brush Kit.....	127-1548

Attachments and Accessories (continued)

Toro Reel Paper (10 Pack).....	125-5610
Toro Reel Shim (0.002in)	125-5611
Weight Kit, Counter-Rotating	120-2760
High Height-of-Cut Arms (Qty 1)	120-9600
Rear Roller Adjustment (Qty 1).....	120-9602
Rear Roller Extension Kit (Set of 3).....	125-5180
Groomer Quick Up Kit.....	127-6119
Angle Indicator.....	131-6828
Angle Indicator Mount.....	131-6829
Bedbar	106-2648-01
Bedbar-Aggressive	99-3794-03
Bedknife-Tournament, Extended	108-4302
Bedknife-Microcut, Extended.....	108-4303
Bedknife-Edgemax, Microcut.....	115-1880
Bedknife-Edgemax, Tournament Cut.....	115-1881
Bedknife-Edgemax	137-0879
Bedknife-Fairway.....	63-8610
Bedknife-Microcut.....	93-4262
Bedknife-Tournament Cut.....	93-4263
Bedknife-Low Cut	93-4264
Bedknife-Highcut	94-6392
21 Inch 8 Blade Low Drag Reel ASM (EdgeSeries+)	137-8511
21 Inch 11 Blade Low Drag Reel ASM (EdgeSeries+).....	137-8512
21 Inch 14 Blade Low Drag Reel ASM (EdgeSeries+).....	137-8513
8 Blade Heavy Duty Reel ASM	137-8517
Blade-Groomer, Helix	110-2333
Blade-Groomer, Thin (Carbide)	121-9531
Blade-Groomer, Universal Harden Blade (Thin)	132-4626
Roller Seal Replacement (Qty 1)	107-1594
MVP Kit, Cutting Unit Re-Build.....	121-2637
MVP Kit, Forward Rotating Groomer Re-Build	121-9517



Count on it.