



Count on it.

Operator's Manual

**Greensmaster® 3300 TriFlex®
Traction Unit**

Model No. 04510—Serial No. 403070001 and Up



g014597



This product complies with all relevant European directives; for details, please see the separate product specific Declaration of Conformity (DOC) sheet.

It is a violation of California Public Resource Code Section 4442 or 4443 to use or operate the engine on any forest-covered, brush-covered, or grass-covered land unless the engine is equipped with a spark arrester, as defined in Section 4442, maintained in effective working order or the engine is constructed, equipped, and maintained for the prevention of fire.

The enclosed engine owner's manual is supplied for information regarding the US Environmental Protection Agency (EPA) and the California Emission Control Regulation of emission systems, maintenance, and warranty. Replacements may be ordered through the engine manufacturer.

⚠ WARNING

CALIFORNIA Proposition 65 Warning

The engine exhaust from this product contains chemicals known to the State of California to cause cancer, birth defects, or other reproductive harm.

Battery posts, terminals, and related accessories contain lead and lead compounds, chemicals known to the State of California to cause cancer and reproductive harm. Wash hands after handling.

Use of this product may cause exposure to chemicals known to the State of California to cause cancer, birth defects, or other reproductive harm.

Introduction

This machine is a ride-on, reel-blade greens mower intended to be used by professional, hired operators in commercial applications. It is primarily designed for cutting grass on well-maintained turf.

Read this information carefully to learn how to operate and maintain your product properly and to avoid injury and product damage. You are responsible for operating the product properly and safely.

Visit www.Exmark.com for more information, including safety tips, training materials, accessory information, help finding a dealer, or to register your product.

Whenever you need service, genuine Toro parts, or additional information, contact an authorized Toro distributor and have the model and serial numbers of your product ready. [Figure 1](#) identifies the location of the model and serial numbers on the product. Write the numbers in the space provided.

Important: With your mobile device, you can scan the QR code on the serial number decal (if equipped) to access warranty, parts, and other product information.

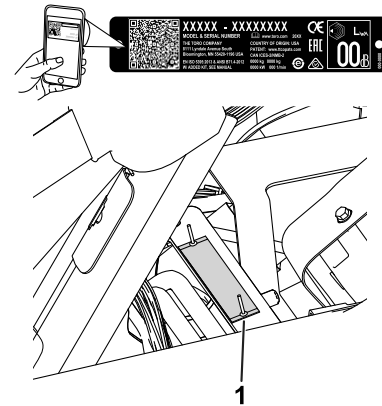

Figure 1

g233264

1. Model and serial number location—lift the seat and locate the serial plate.

Model No. _____

Serial No. _____

This manual identifies potential hazards and has safety messages identified by the safety-alert symbol ([Figure 2](#)), which signals a hazard that may cause serious injury or death if you do not follow the recommended precautions.



Figure 2
Safety-alert symbol

g000502

Contents

Safety	4
General Safety	4
Safety and Instructional Decals	5
Setup	9
1 Installing the Roll Bar	10
2 Installing the Seat	10
3 Installing the Steering Wheel.....	11
4 Activating and Charging the Battery	11
5 Installing the Oil Cooler	12
6 Installing the Grass-Basket Hooks	12
7 Installing the Cutting Units	13
8 Adding Rear Weight.....	13
9 Installing the CE Decals	14
10 Reducing the Tire Pressure.....	14
11 Burnishing the Brakes	14
Product Overview	15
Controls	15
Specifications	18
Attachments/Accessories.....	18
Before Operation	19
Before Operation Safety	19
Fuel Specification	19
Filling the Fuel Tank.....	19
Performing Daily Maintenance.....	20
During Operation	20
During Operation Safety	20
Breaking in the Machine	21
Starting the Engine	22
Checking the Machine after Starting the Engine.....	22
Shutting Off the Engine.....	22
Checking the Safety-Interlock System	22
Driving the Machine without Mowing.....	23
Mowing the Green	23
After Operation	25
After Operation Safety	25
Inspecting and Cleaning after Mowing	25
Hauling the Machine	26
Towing the Machine	26
Maintenance	27
Recommended Maintenance Schedule(s)	27
Daily Maintenance Checklist.....	28
Pre-Maintenance Procedures	29
Maintenance Safety.....	29
Engine Maintenance	29
Engine Safety	29
Servicing the Air Cleaner	29
Servicing the Engine Oil.....	30
Replacing the Spark Plugs.....	31
Fuel System Maintenance	31
Replacing the Fuel Filter	31
Inspecting the Fuel Lines and Connections.....	31
Electrical System Maintenance	32
Electrical System Safety	32
Servicing the Battery.....	32

This manual uses 2 words to highlight information. **Important** calls attention to special mechanical information and **Note** emphasizes general information worthy of special attention.

Safety

This machine has been designed in accordance with EN ISO 5395:2013 and ANSI B71.4-2017 and meets these standards when you complete the setup and install the seat, rollbar, and appropriate weight kit.

General Safety

This product is capable of amputating hands and feet and of throwing objects.

Using this product for purposes other than its intended use could prove dangerous to you and bystanders.

- Read and understand the contents of this *Operator's Manual* before starting the engine.
- Use your full attention while operating the machine. Do not engage in any activity that causes distractions; otherwise, injury or property damage may occur.
- Do not put your hands or feet near moving components of the machine.
- Do not operate the machine without all guards and other safety protective devices in place and working on the machine.
- Keep clear of any discharge opening.
- Keep children, bystanders, and pets out of the operating area. Never allow children to operate the machine.
- Always shut off the engine, remove the key (if equipped), wait for all moving parts to stop, and allow the machine to cool before adjusting, repairing, cleaning, or storing the machine.

Improperly using or maintaining this machine can result in injury. To reduce the potential for injury, comply with these safety instructions and always pay attention to the safety-alert symbol (Figure X), which means Caution, Warning, or Danger—personal safety instruction. Failure to comply with these instructions may result in personal injury or death.

Locating the Fuses	33
Drive System Maintenance	33
Checking the Tire Pressure.....	33
Checking the Torque of the Wheel Nuts	33
Adjusting the Transmission for Neutral.....	33
Adjusting the Transport Speed.....	34
Adjusting the Mowing Speed	35
Brake Maintenance	35
Burnishing the Brakes.....	35
Adjusting the Brakes.....	35
Hydraulic System Maintenance	36
Hydraulic System Safety.....	36
Servicing the Hydraulic Fluid	36
Checking the Hydraulic Lines and Hoses.....	38
Checking the Leak Detector.....	38
Cutting Unit Maintenance	40
Blade Safety	40
Installing and Removing the Cutting Units.....	40
Checking the Reel-to-Bedknife Contact	43
Setting the Reel Speed	43
Backlapping the Reels	43
Diagnostics System	44
Diagnosing the Service Indicator Light	44
Storage	45

Safety and Instructional Decals



Safety decals and instructions are easily visible to the operator and are located near any area of potential danger. Replace any decal that is damaged or missing.

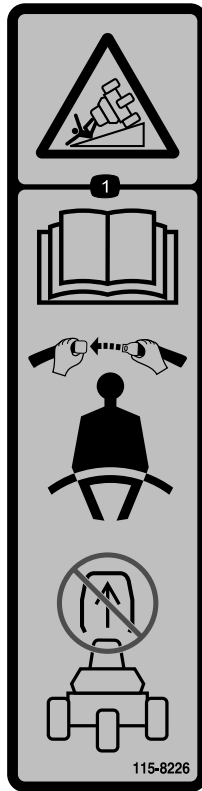

115-8226

decal115-8226

1. Tipping hazard—read the *Operator's Manual*; always wear a seat belt when operating; do not remove the rollover protection system (ROPS).



133-8062

decal133-8062

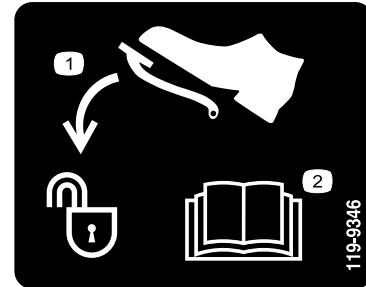

119-9346

decal119-9346

1. Press the pedal to unlock.
2. Read the *Operator's Manual* for more information.

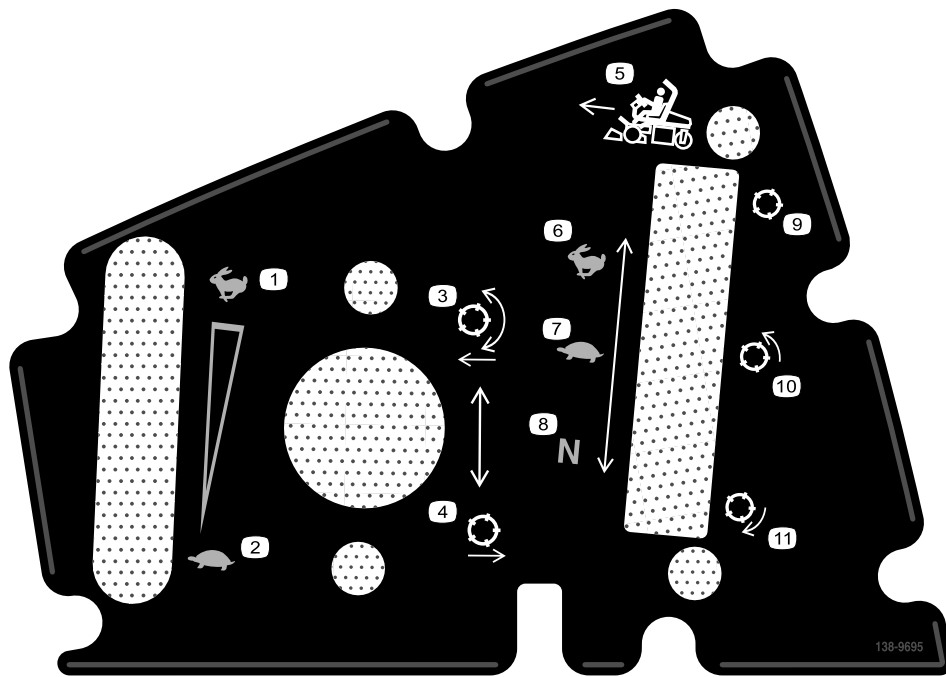

138-9695

decal138-9695

- | | |
|-----------------------------------|-----------------------|
| 1. Engine speed—Fast | 7. Reel speed—Neutral |
| 2. Engine speed—Slow | 8. Reel—Transport |
| 3. Lower and engage the reels. | 9. Reel—Mow |
| 4. Raise and disengage the reels. | 10. Reel—Backlapping |
| 5. Reel speed—Fast | 11. Move forward. |
| 6. Reel speed—Slow | |

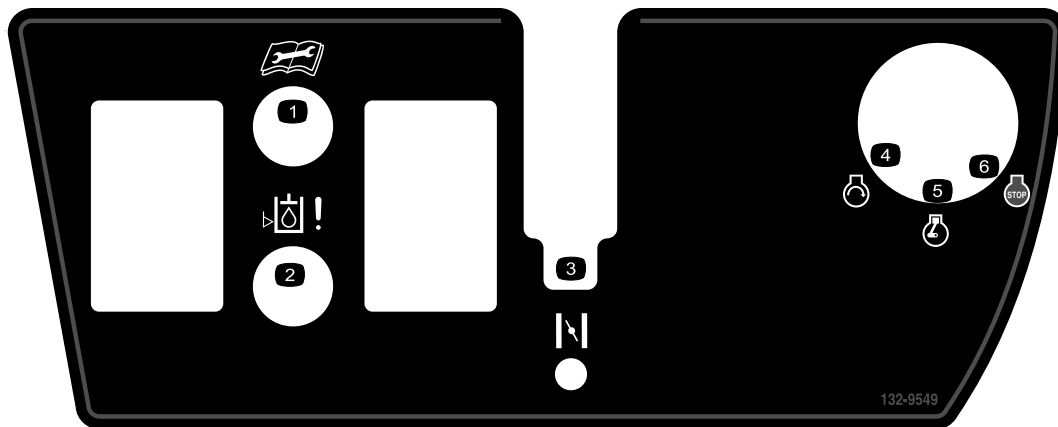

132-9549

decal132-9549

- | | |
|--|-----------------|
| 1. Read the <i>Operator's Manual</i> before servicing or performing maintenance. | 4. Engine—start |
| 2. Hydraulic-fluid level | 5. Engine—run |
| 3. Choke | 6. Engine—stop |



Battery Symbols

Some or all of these symbols are on your battery.

- | | |
|--|--|
| 1. Explosion hazard | 6. Keep bystanders a safe distance away from the battery. |
| 2. No fire, open flame, or smoking | 7. Wear eye protection; explosive gasses can cause blindness and other injuries. |
| 3. Caustic liquid/chemical burn hazard | 8. Battery acid can cause blindness or severe burns. |
| 4. Wear eye protection. | 9. Flush eyes immediately with water and get medical help fast. |
| 5. Read the <i>Operator's Manual</i> . | 10. Contains lead; do not discard |

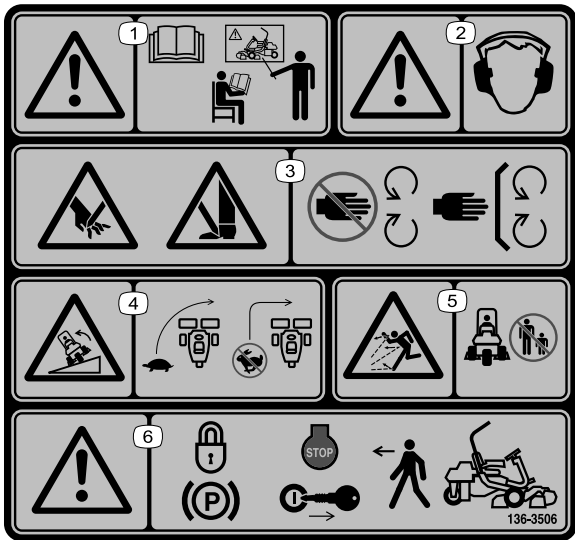

136-8506

- | | |
|---|---|
| 1. Warning—read the <i>Operator's Manual</i> ; receive training before operating the machine. | 4. Tipping hazard—slow machine before turning, do not turn at high speeds. |
| 2. Warning—hearing protection must be worn. | 5. Thrown object hazard—keep bystanders a safe distance away from the machine. |
| 3. Cutting/dismemberment hazard of hands or feet—keep all guards and shields in place. | 6. Warning—engage the parking brake, shut off the engine, and remove the ignition key before leaving the machine. |

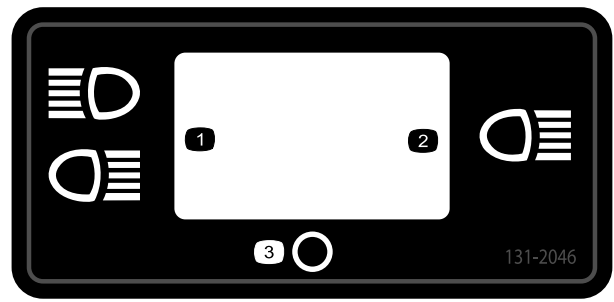

131-2046

- | | |
|------------------|--------|
| 1. Double lights | 3. Off |
| 2. Single light | |

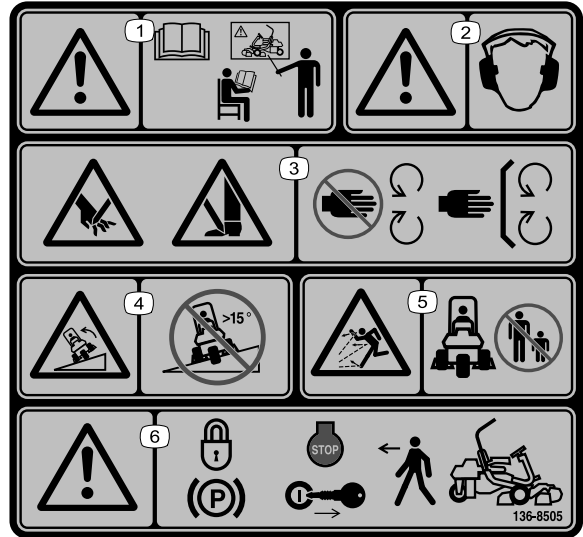

136-8505

Replaces Decal 136-8506 for CE Machines

Note: This machine complies with the industry standard stability test in the static lateral and longitudinal tests with the maximum recommended slope indicated on the decal. Review the instructions for operating the machine on slopes in the *Operator's Manual* as well as the conditions in which you would operate the machine to determine whether you can operate the machine in the conditions on that day and at that site. Changes in the terrain can result in a change in slope operation for the machine. If possible, keep the cutting units lowered to the ground while operating the machine on slopes. Raising the cutting units while operating on slopes can cause the machine to become unstable.

- | | |
|---|---|
| 1. Warning—read the <i>Operator's Manual</i> ; receive training before operating the machine. | 4. Tipping hazard—do not drive across or down slopes greater than 15 degrees. |
| 2. Warning—hearing protection must be worn. | 5. Thrown object hazard—keep bystanders a safe distance away from the machine. |
| 3. Cutting/dismemberment hazard of hand or foot, mower blade—stay away from moving parts; keep all guards and shields in place. | 6. Warning—engage the parking brake, shut off the engine, and remove the ignition key before leaving the machine. |

GREENSMASTER 3XXX

1	2		3		4		5	6
	3.8 MPH 6.1 Km/h	5.0 MPH 8.0 Km/h	3.8 MPH 6.1 Km/h	5.0 MPH 8.0 Km/h	3.8 MPH 6.1 Km/h	5.0 MPH 8.0 Km/h	3.8 MPH 6.1 Km/h	
0.062" / 1.6mm	N/R	N/R	9	N/R	9	N/R	9	
0.094" / 2.4mm	N/R	N/R	9	N/R	9	N/R	9	
0.125" / 3.2mm	N/R	N/R	9	N/R	9	N/R	9	
0.156" / 4.0mm	N/R	N/R	9	N/R	9	N/R	N/R	
0.188" / 4.8mm	N/R	N/R	9	N/R	7	N/R	N/R	
0.218" / 5.5mm	N/R	N/R	9	N/R	6	N/R	N/R	
0.250" / 6.4mm	7	N/R	6	7	5	7	N/R	
0.312" / 7.9mm	6	N/R	5	6	4	6	N/R	
0.375" / 9.5mm	6	7	4	5	4	5	N/R	
0.438" / 11.1mm	6	6	4	5	3	4	N/R	
0.500" / 12.7mm	5	6	3	4	N/R	N/R	N/R	
0.625" / 15.9mm	4	5	3	3	N/R	N/R	N/R	
0.750" / 19.0mm	3	4	3	3	N/R	N/R	N/R	
0.875" / 22.2mm	3	4	N/R	3	N/R	N/R	N/R	
1.000" / 25.4mm	3	3	N/R	N/R	N/R	N/R	N/R	

115-8156

decal115-8156

115-8156

- | | | | |
|-------------------------|--------------------------|--------------------------|---------|
| 1. Reel height | 3. 8-blade cutting unit | 5. 14-blade cutting unit | 7. Fast |
| 2. 5-blade cutting unit | 4. 11-blade cutting unit | 6. Reel speed | 8. Slow |

GREENSMASTER 3300/3320 TriFlex QUICK REFERENCE AID

SEE OPERATOR'S MANUAL

CHOCK/SERVICE (daily)

1. OIL LEVEL, ENGINE
2. OIL LEVEL, HYDRAULIC TANK
3. BRAKE FUNCTION
4. INTERLOCK SYSTEM:
 - 4a. SEAT INTERLOCK
 - 4b. NEUTRAL SENSOR
 - 4c. MOW SENSOR
 - 4d. PARKING BRAKE INTERLOCK
5. LEAK DETECTOR ALARM
6. AIR FILTER / PRECLEANER
7. ENGINE COOLING FINS
8. TIRE PRESSURE (12 - 16 psi)
9. BATTERY
10. WHEEL NUT TORQUE (70-90 FT LBS)
11. FUEL - GAS
12. REEL SPEED / BACKLAP CONTROL

FLUID SPECIFICATIONS / CHANGE INTERVALS

See operator's manual for initial change	FLUID TYPE	CAPACITY		CHANGE INTERVALS		FILTER PART NO.
		L	QTS.	FLUID	FILTER	
A. ENGINE OIL	SAE 10W-30 SJ	1.6*	1.75*	100 HRS.	100 HRS.	107-7817
B. AIR CLEANER	_____	_____	_____	_____	100 HRS.	692519
C. FUEL FILTER	_____	_____	_____	_____	1000 HRS.	94-2690
D. HYDRAULIC OIL (3300)	ISO VG 46	22.7*	24*	800 HRS.	800 HRS.	108-5194
D. HYDRAULIC OIL (3320)	ISO VG 46	18.9*	20*	800 HRS.	800 HRS.	108-5194
E. FUEL TANK	UNLEADED GAS	22.7	6 GAL.	_____	_____	_____

*Including filter

119-9345

decal119-9345

119-9345

Setup

Loose Parts

Use the chart below to verify that all parts have been shipped.

Procedure	Description	Qty.	Use
1	Roll bar	1	Install the roll bar.
	Bolt (1/2 x 3-3/4 inches)	4	
	Flange nut (1/2 inch)	4	
2	Seat	1	Install the seat to the base.
	Seat wire harness	1	
3	Steering wheel	1	Install the steering wheel.
	Locknut (1-1/2 inches)	1	
	Washer	1	
	Steering-wheel cap	1	
4	No parts required	–	Activate and charge the battery.
5	Oil Cooler Kit—Greensmaster 3300 Series Traction Unit (Part No. 119-1691 [purchased separately])	–	Install the optional oil cooler.
6	Grass-basket hook	6	Install the grass-basket hooks.
	Flange bolts	12	
7	Gauge bar	1	Install the cutting units.
	Cutting unit (obtain from your authorized Toro distributor)	3	
	Grass basket	3	
8	Weight kit (Part No. 119-7129)—sold separately	1	Add rear weight.
9	Warning decal (Part No. 136-8505)	1	Install the CE decals (if required).
	CE mark decal	1	
10	No parts required	–	Reduce the tire pressure.
11	No parts required	–	Burnish the brakes.

Media and Additional Parts

Description	Qty.	Use
Operator's Manual	1	Review it before operating the machine.
Engine owner's manual	1	Use it to reference engine information.
Declaration of Conformity	1	For CE compliance
Noise rating certificate	1	
Ignition keys	2	Start the engine.

1

Installing the Roll Bar

Parts needed for this procedure:

1	Roll bar
4	Bolt (1/2 x 3-3/4 inches)
4	Flange nut (1/2 inch)

Procedure

1. Remove the top crate support from the crate.
2. Remove the roll bar from the crate.
3. Use 4 bolts (1/2 x 3-3/4 inches) and 4 flange nuts (1/2 inch) to install the roll bar into the ROPS brackets on each side of the machine as shown in [Figure 3](#).

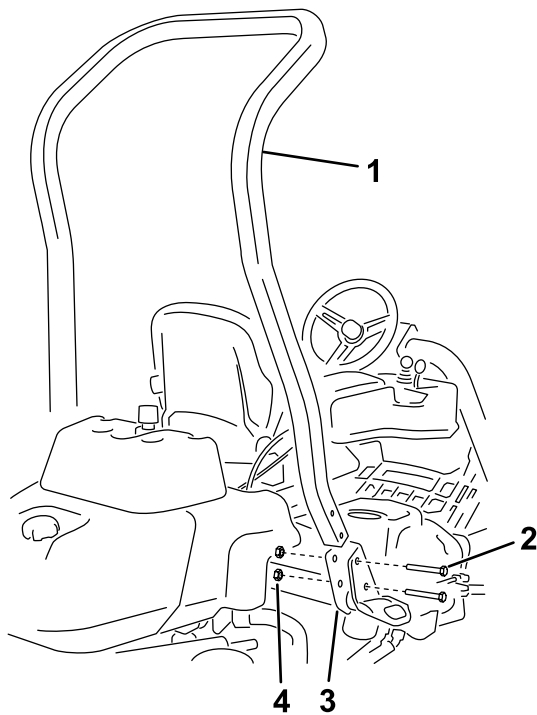

Figure 3

g233739

- | | |
|------------------------------|--------------------------|
| 1. Roll bar | 3. ROPS bracket |
| 2. Bolt (1/2 x 3-3/4 inches) | 4. Flange nut (1/2 inch) |

4. Torque the fasteners to 136 to 149 N·m (100 to 110 ft·lb).

2

Installing the Seat

Parts needed for this procedure:

1	Seat
1	Seat wire harness

Procedure

Note: Mount the seat in the front set of mounting holes to gain an additional 7.6 cm (3 inches) in the forward adjustment, or in the rear mounting holes for an additional 7.6 cm (3 inches) in the rearward adjustment.

1. Remove and discard the lag bolts securing the seat slides and cut the shipping straps.
2. Remove the 4 bolts (5/16 x 3/4 inch) and washers from the shipping bracket and discard the bracket.
3. Secure the seat to the seat base with 4 bolts and washers removed previously ([Figure 4](#)).

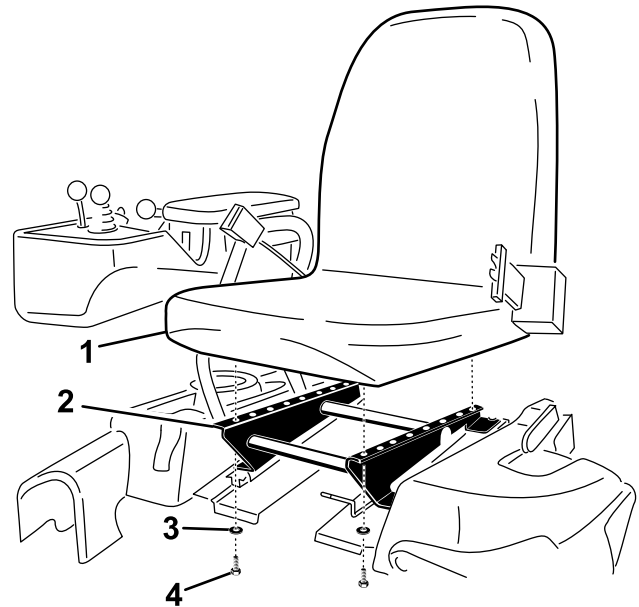

Figure 4

g193736

- | | |
|--------------|---------------------------|
| 1. Seat | 3. Washer |
| 2. Seat base | 4. Bolt (5/16 x 3/4 inch) |

4. Locate the open connector on the main wiring harness to the right of the seat and connect it to the wire harness that came with the seat.
5. Route the seat wiring harness around the seat slides, ensuring that it is not pinched when the

seat moves, and connect it to the port on the bottom of the seat.

3

Installing the Steering Wheel

Parts needed for this procedure:

1	Steering wheel
1	Locknut (1-1/2 inches)
1	Washer
1	Steering-wheel cap

Procedure

- Slide the steering wheel onto the steering shaft (Figure 5).

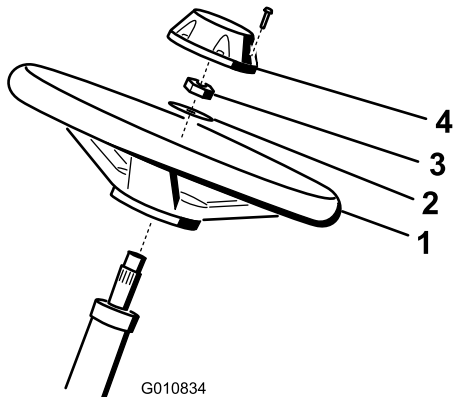

Figure 5

- | | |
|-------------------|------------|
| 1. Steering wheel | 3. Locknut |
| 2. Washer | 4. Cap |

- Slide the washer onto the steering shaft (Figure 5).
- Secure the steering wheel to the shaft with a locknut and tighten it to 27 to 35 N·m (20 to 26 ft-lb) (Figure 5).
- Install the cap to the steering wheel and secure it with 6 bolts (Figure 5).

4

Activating and Charging the Battery

No Parts Required

Procedure

Use only electrolyte (1.265 specific gravity) to fill the battery initially.

⚠ WARNING

Battery terminals or metal tools could short against metal machine components, causing sparks. Sparks can cause the battery gasses to explode, resulting in personal injury.

- When removing or installing the battery, do not allow the battery terminals to touch any metal parts of the machine.
- Do not allow metal tools to short between the battery terminals and metal parts of the machine.

- Remove the fasteners and battery clamp and lift out the battery.

Important: Do not add electrolyte while the battery is in the machine. You could spill it, causing corrosion.

- Clean the top of the battery and remove the vent caps (Figure 6).

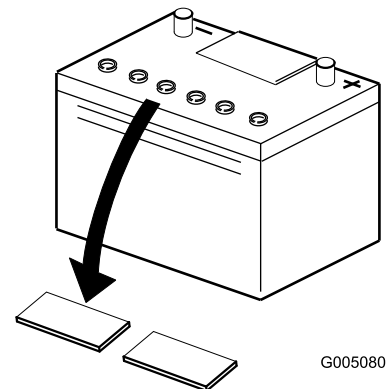

Figure 6

- Carefully fill each cell with electrolyte until the plates are covered with about 6 mm (1/4 inch) of fluid (Figure 7).

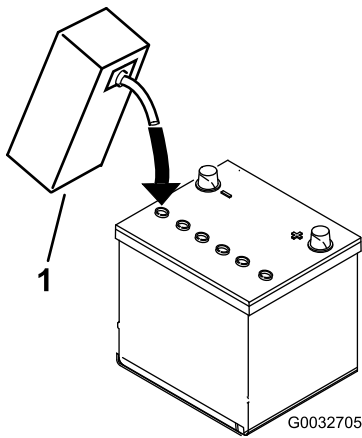

Figure 7

1. Electrolyte

4. Allow approximately 20 to 30 minutes for the electrolyte to soak into the plates. Fill as necessary to bring the electrolyte to within about 6 mm (1/4 inch) of the bottom of the fill well (Figure 7).
5. Connect a 2 to 4 A battery charger to the battery posts. Charge the battery for at least 2 hours at 4 A or for at least 4 hours at 2 A until the specific gravity is 1.250 or higher and the temperature is at least 16°C (60°F) with all cells gassing freely.

⚠ WARNING

Charging the battery produces gasses that can explode.

Never smoke near the battery and keep sparks and flames away from the battery.

Important: If you do not charge the battery for at least the time specified above, you may reduce the life of the battery.

6. When the battery is charged, disconnect the charger from the electrical outlet and battery posts.

Note: After the battery has been activated, add only distilled water to replace normal loss, although maintenance-free batteries should not require water under normal operating conditions.

Important: Failure to correctly activate the battery may result in battery gassing and/or premature battery failure.

7. Install the vent caps.
8. Place the battery on the battery tray and secure it with the battery clamp and fasteners removed previously.
9. Install the positive cable (red) to the positive (+) terminal and then the negative cable (black) to the negative (-) terminal of the battery and

secure them with the bolts and nuts (Figure 8). Slide the rubber boot over the positive terminal to prevent a possible short from occurring.

⚠ WARNING

Incorrect battery cable routing could damage the tractor and cables, causing sparks. Sparks can cause the battery gasses to explode, resulting in personal injury.

- Always disconnect the negative (black) battery cable before disconnecting the positive (red) cable.
- Always connect the positive (red) battery cable before connecting the negative (black) cable.

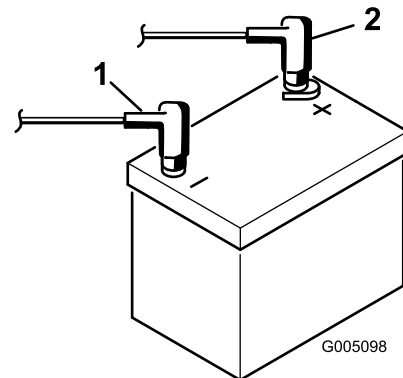

Figure 8

1. Negative (-)
2. Positive (+)

5

Installing the Oil Cooler

Optional

Parts needed for this procedure:

-	Oil Cooler Kit—Greensmaster 3300 Series Traction Unit (Part No. 119-1691 [purchased separately])
---	--

Procedure

If you are operating the machine in hot climates, where the ambient temperature is above 29°C (85°F), or using it for heavy-duty use (mowing other than greens, such as fairways or verticutting), install the optional hydraulic oil cooler kit (Part No. 119-1691).

6

Installing the Grass-Basket Hooks

Parts needed for this procedure:

6	Grass-basket hook
12	Flange bolts

Procedure

Install the 6 grass-basket hooks onto the ends of the suspension-arm bars using the 12 flange bolts ([Figure 9](#)).

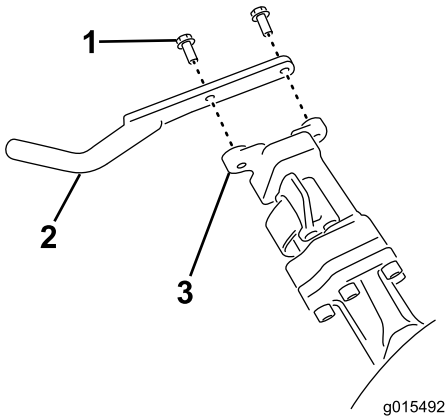

Figure 9

- 1. Flange bolt
- 2. Grass-basket hook
- 3. Suspension-arm bar

7

Installing the Cutting Units

Parts needed for this procedure:

1	Gauge bar
3	Cutting unit (obtain from your authorized Toro distributor)
3	Grass basket

Procedure

1. Prepare the cutting units for installation; refer to your cutting unit *Operator's Manual*.
2. Apply grease to the inside diameter of the drive coupler.
3. Install the cutting units; refer to [Installing the Cutting Units \(page 41\)](#).

8

Adding Rear Weight

Parts needed for this procedure:

1	Weight kit (Part No. 119-7129)—sold separately
---	--

Procedure

This machine complies with ANSI B71.4-2017 and EN ISO 5395:2013 when equipped with the Weight Kit (Part No. 119-7129).

9

Installing the CE Decals

Parts needed for this procedure:

1	Warning decal (Part No. 136-8505)
1	CE mark decal

Procedure

If you use this machine in a country that complies to CE standards, perform the following steps after you install the guard kit to the machine:

- Apply the CE warning decal (Part No. 136-8505) over the existing warning decal (Part No. 136-8506).
- Apply the CE mark decal to the frame under the front of the seat ([Figure 10](#)).

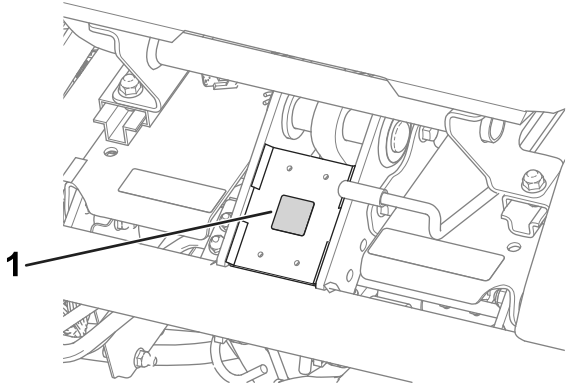

Figure 10

g233420

1. CE mark decal

10

Reducing the Tire Pressure

No Parts Required

Procedure

The tires are overinflated at the factory for shipping purposes. Reduce the pressure to the proper levels before starting the machine; refer to [Checking the Tire Pressure \(page 33\)](#).

11

Burnishing the Brakes

No Parts Required

Procedure

Burnish the brakes; refer to [Burnishing the Brakes \(page 35\)](#).

Product Overview

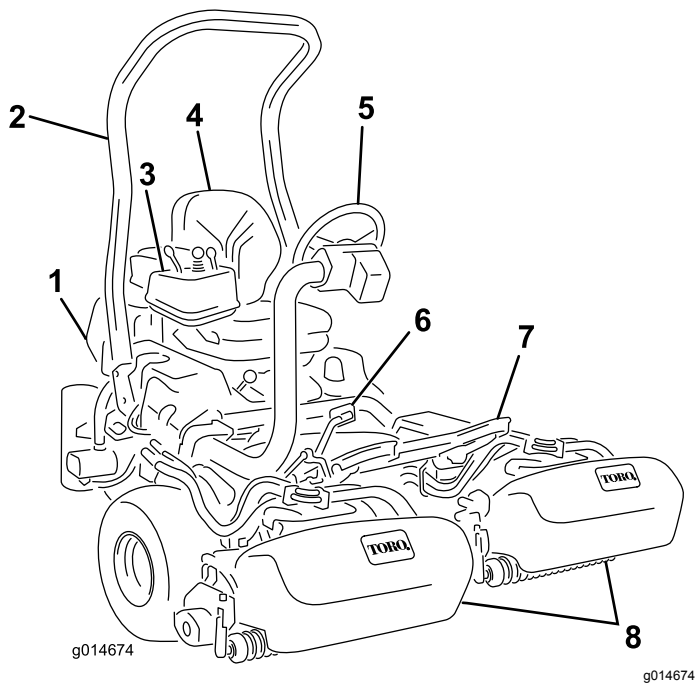

Figure 11

- | | |
|------------------|-------------------|
| 1. Engine | 5. Steering wheel |
| 2. Roll bar | 6. Traction pedal |
| 3. Control panel | 7. Footrest |
| 4. Seat | 8. Cutting units |

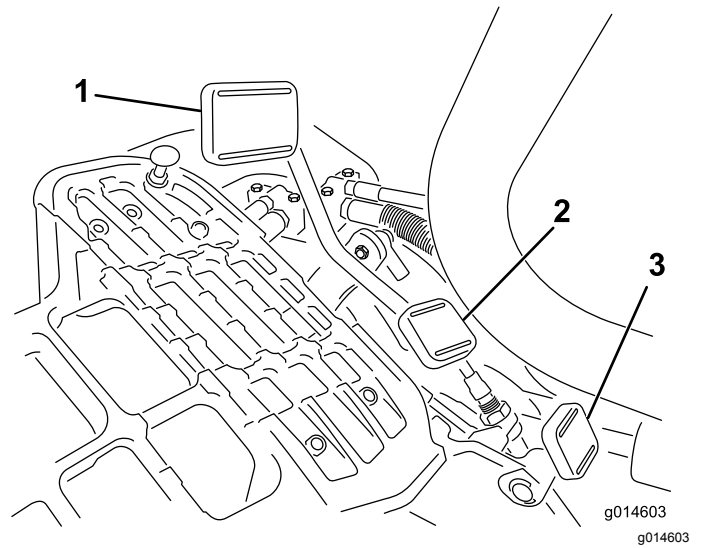

Figure 12

- | | |
|---------------------------|-------------------------------|
| 1. Traction pedal—forward | 3. Steering-arm-locking pedal |
| 2. Traction pedal—reverse | |

Controls

Traction Pedal

The traction pedal (Figure 12) has 3 functions: to make the machine move forward, to move it backward, and to stop the machine. Press the top of the pedal to move forward and the bottom of the pedal to move backward or to assist in stopping when moving forward. Also, allow the pedal to move to the neutral position to stop the machine. For your comfort, do not rest the heel of your foot on the reverse pad of the traction pedal when you are driving the machine forward. (Figure 13).



Figure 13

Ground speeds are as follows:

- 3.2 to 8 km/h (2 to 5 mph) forward mowing speed
- 16 km/h (10 mph) maximum transport speed
- 4.0 km/h (2.5 mph) reverse speed

Steering-Arm-Locking Pedal

Press the pedal (Figure 12) and raise or lower the steering arm for operator comfort, then, release the pedal to lock the arm in place.

Throttle Lever

Use the throttle lever (Figure 14) to control the speed of the engine. Move the throttle lever toward the FAST position to increase the engine speed; move it toward the SLOW position to decrease the engine speed.

Note: You cannot stop the engine using the throttle lever.

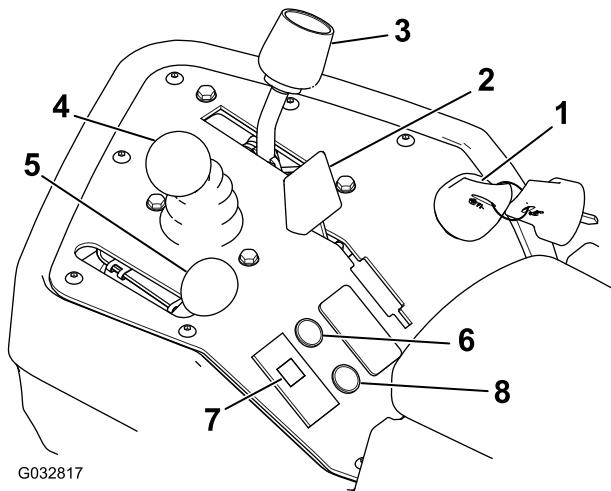

Figure 14

- | | |
|-----------------------------|------------------------------|
| 1. Ignition switch | 5. Throttle lever |
| 2. Choke lever | 6. Service-indicator light |
| 3. Functional-control lever | 7. Engine-oil-pressure light |
| 4. Raise/lower mow control | 8. Leak-indicator light |

Choke Lever

To start a cold engine, close the carburetor choke by pushing the choke lever forward (Figure 14) to the CLOSED position. After the engine starts, regulate the choke lever to keep the engine running smoothly. As soon as possible, open the choke by pulling the lever rearward to the OPEN position. A warm engine requires little or no choking.

Raise/Lower Mow Control

Moving the control (Figure 14) forward during cutting operation lowers the cutting units and starts the reels. Pull back on the control to stop the reels and raise the cutting units. To stop the reels without raising the cutting units, pull back on the control momentarily and releasing it. Start the reels by moving the control forward.

Functional Control Lever

The functional control lever (Figure 14) provides 2 traction selections plus a NEUTRAL position. You can shift from mow to transport or transport to mow (not to neutral) while the machine is in motion; no damage will result.

- REAR position—neutral position; use when backlapping the reels
- MIDDLE position—use when cutting grass
- FRONT position—use when driving the machine between job sites

Ignition Switch

Insert the key into the switch (Figure 14) and turn it clockwise to the START position to start the engine. Release the key as soon as the engine starts; the key moves to the ON position. Turn the key counterclockwise to the STOP position to shut off the engine.

Engine-Oil Pressure Light

The light (Figure 14) glows if the engine-oil pressure drops below a safe level.

Service Indicator Light

The service indicator light (Figure 14) illuminates when the machine sensors detect an issue with 1 of the systems of the machine. If this light illuminates, stop what you are doing and drive to a safe location where you or a service technician can diagnose the problem. For more information on diagnosing system issues using the service indicator light, refer to [Diagnosing the Service Indicator Light \(page 44\)](#).

Leak-Indicator Light

This light illuminates and an alarm sounds if the hydraulic fluid level drops in the hydraulic reservoir; refer to [Operating the Leak Detector \(page 40\)](#) and [Checking the Hydraulic-Fluid Level \(page 36\)](#).

Hour Meter

The hour meter (Figure 15) indicates the total hours the machine has operated. It starts to function whenever you rotate the ignition switch to the ON position.

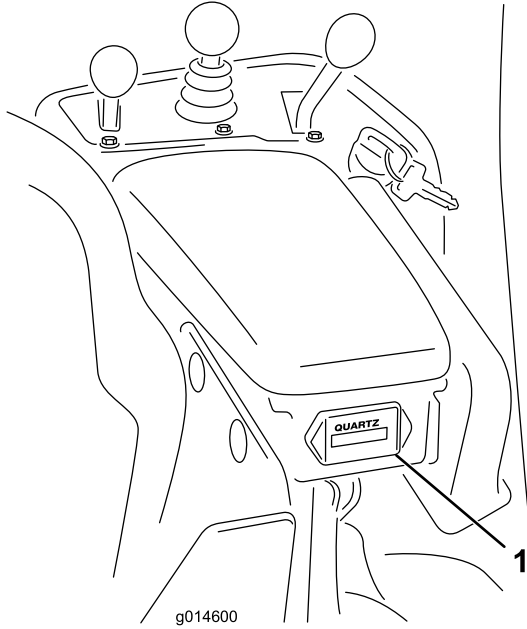

Figure 15

1. Hour meter

Parking Brake Lever

Pull the brake lever (Figure 16) to engage the parking brake. Disengage it by squeezing the release lever on the underside of the brake lever and lowering it to the released position. Engage the parking brake whenever you leave the machine.

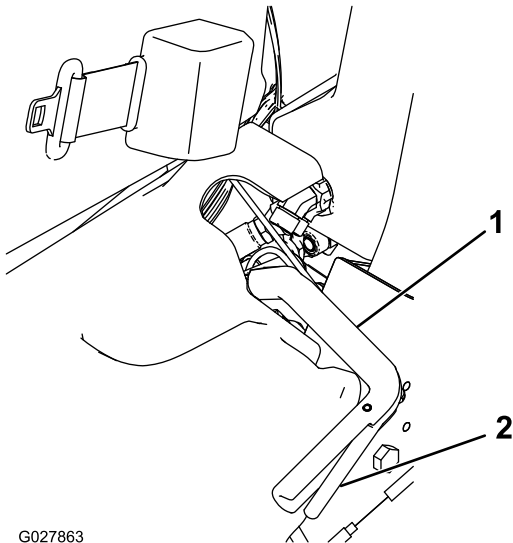

Figure 16

1. Parking-brake lever
2. Release lever

Backlap Lever

The backlap lever is located under the plastic cover to the left of the seat. Use the backlap lever (Figure 17) in conjunction with the raise/lower mower control lever and the reel-speed control for backlapping the reels.

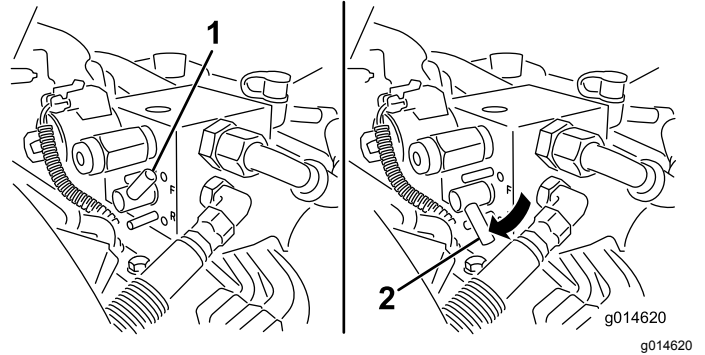

Figure 17

1. Backlap lever—mow position
2. Backlap lever—backlap position

Reel-Speed Control

The reel-speed control is located under the plastic cover to the left of the seat. Use the reel-speed control (Figure 18) to adjust the speed of the reels.

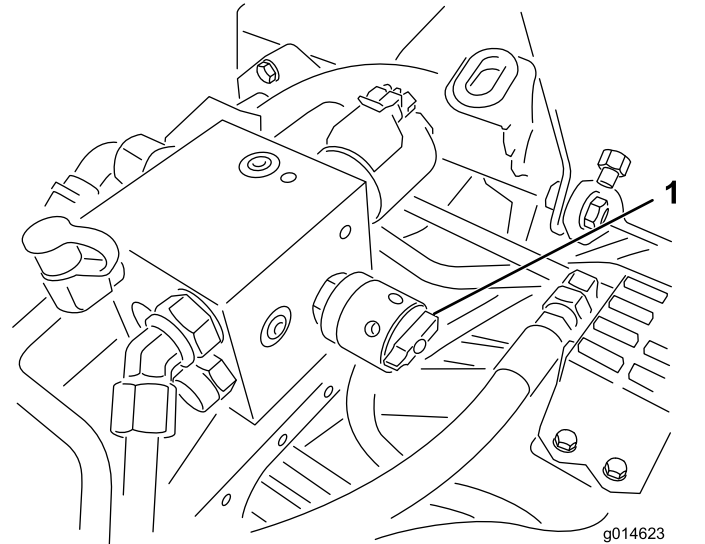

Figure 18

1. Reel-speed control

Seat-Adjusting Lever

The seat-adjusting lever is located on the front, left corner of the seat (Figure 19), allowing you to adjust the seat forward and rearward.

Note: If you need additional adjustment on the seat, you can remove the 4 nuts securing the seat slide rails to the base and move the seat slide rails to the second set of mounting holes provided.

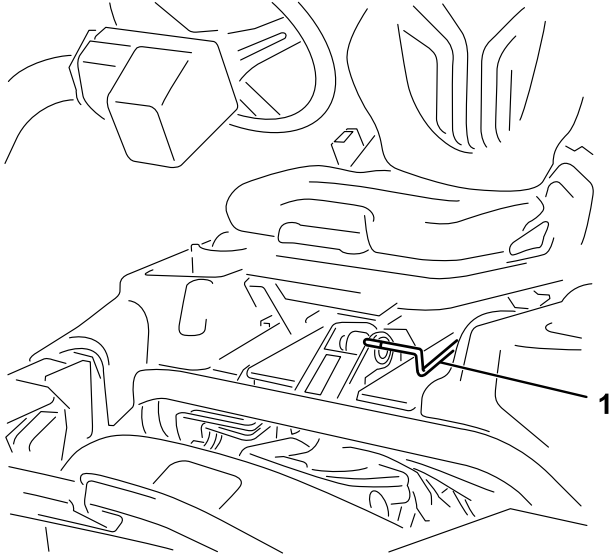

Figure 19

1. Seat-adjusting handle

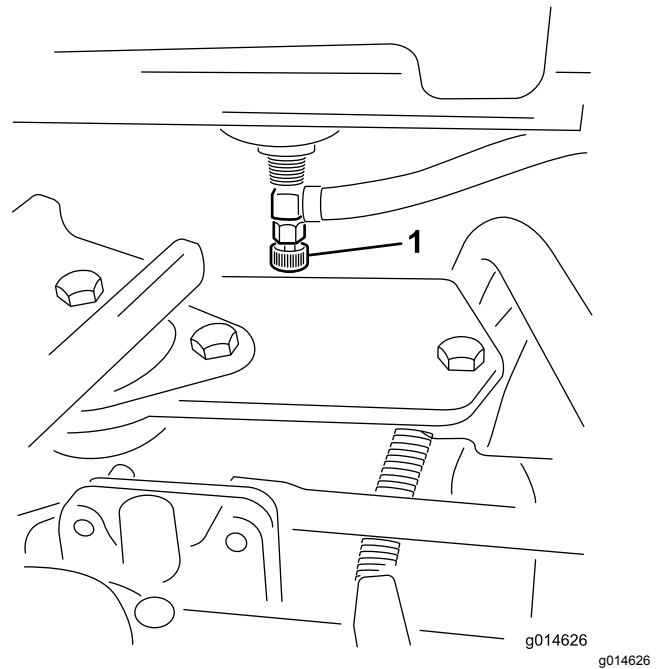

Figure 20

1. Fuel shutoff (under the fuel tank)

Specifications

Note: Specifications and design are subject to change without notice.

Width of cut	151 cm (59.5 inches)
Wheel tread	128 cm (50.5 inches)
Wheel base	119 cm (46.9 inches)
Overall length (w/baskets)	249 cm (98.0 inches)
Overall width	179 cm (70.6 inches)
Overall height	205 cm (80.8 inches)
Net weight w/reels (8 blade)	633 kg (1,395 lb)

Attachments/Accessories

A selection of Toro approved attachments and accessories is available for use with the machine to enhance and expand its capabilities. Contact your Authorized Service Dealer or authorized Toro distributor or go to www.Exmark.com for a list of all approved attachments and accessories.

To ensure optimum performance and continued safety certification of the machine, use only genuine Toro replacement parts and accessories. Replacement parts and accessories made by other manufacturers could be dangerous, and such use could void the product warranty.

Operation

Note: Determine the left and right sides of the machine from the normal operating position.

Before Operation

Before Operation Safety

General Safety

- Never allow children or untrained people to operate or service the machine. Local regulations may restrict the age of the operator. The owner is responsible for training all operators and mechanics.
- Become familiar with the safe operation of the equipment, operator controls, and safety signs.
- Always shut off the engine, remove the key (if equipped), wait for all moving parts to stop, and allow the machine to cool before adjusting, repairing, cleaning, or storing the machine. Know how to stop the machine and shut off the engine quickly.
- Check that operator-presence controls, safety switches, and shields are attached and functioning properly. Do not operate the machine unless they are functioning properly.
- Before mowing, always inspect the machine to ensure that the cutting units are in good working condition.
- Inspect the area where you will use the machine and remove all objects that the machine could throw.

Fuel Safety

- Use extreme care in handling fuel. It is flammable and its vapors are explosive.
- Extinguish all cigarettes, cigars, pipes, and other sources of ignition.
- Use only an approved fuel container.
- Do not remove the fuel cap or fill the fuel tank while the engine is running or hot.
- Do not add or drain fuel in an enclosed space.
- Do not store the machine or fuel container where there is an open flame, spark, or pilot light, such as on a water heater or other appliance.
- If you spill fuel, do not attempt to start the engine; avoid creating any source of ignition until the fuel vapors have dissipated.

Fuel Specification

Fuel tank capacity: 26.6 L (7 US gallons)

Recommended Fuel: Unleaded gasoline with an octane rating of 87 or higher ((R+M)/2 rating method)

Ethanol: Gasoline with up to 10% ethanol (gasohol) or 15% MTBE (methyl tertiary butyl ether) by volume is acceptable. Ethanol and MTBE are not the same. Gasoline with 15% ethanol (E15) by volume is not approved for use.

- **Never use gasoline that contains more than 10% ethanol by volume**, such as E15 (contains 15% ethanol), E20 (contains 20% ethanol), or E85 (contains up to 85% ethanol).
- **Do not** use fuel that contains methanol.
- **Do not** store fuel either in the fuel tank or fuel containers over the winter, unless you use a fuel stabilizer.
- **Do not** add oil to gasoline.
- For best results, use only clean, fresh (less than 30 days old) fuel.
- Using unapproved gasoline may cause performance problems and/or engine damage, which may not be covered under the warranty.

Important: Do not use fuel additives other than a fuel stabilizer/conditioner. Do not use fuel stabilizers with an alcohol base such as ethanol, methanol, or isopropanol.

Filling the Fuel Tank

1. Clean around the fuel-tank cap and remove it (Figure 21 or Figure 22).

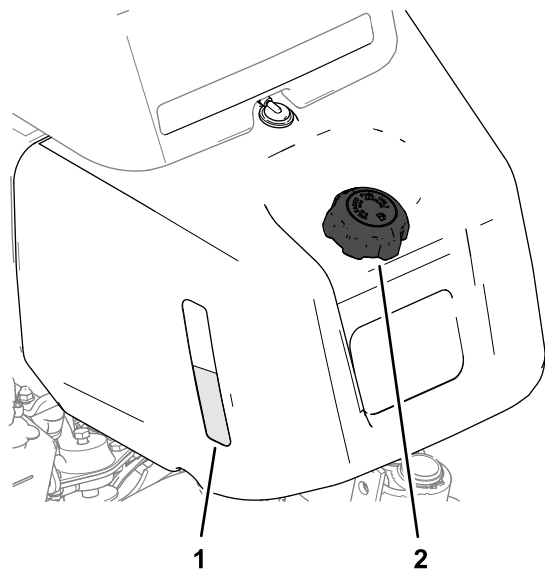

Figure 21

Machines with a fuel tank sight gauge.

1. Fuel tank sight gauge
2. Fuel-tank cap

g227928

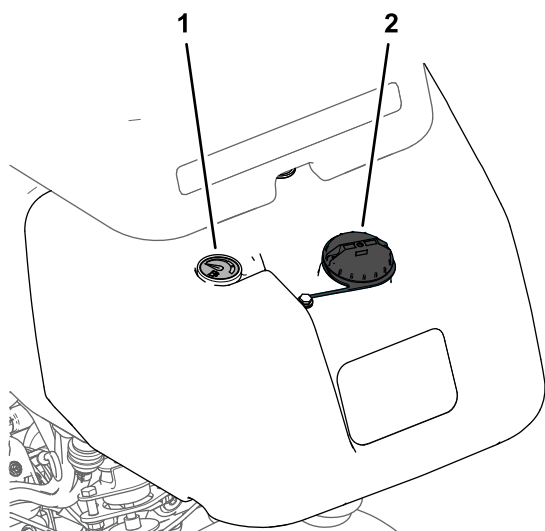

Figure 22

Machines with a fuel gauge.

1. Fuel gauge
2. Fuel-tank cap

2. Add the specified fuel to the fuel tank until the level is 25 mm (1 inch) below the bottom of the filler neck.

This space in the tank allows the fuel to expand. Watch the fuel level in the sight gauge or fuel gauge when you are filling the tank.

Important: Do not fill the fuel tank completely full.

3. Install the cap.

Note: You will hear a click sound when the cap is secure.

4. Wipe up any spilled fuel.

Performing Daily Maintenance

Service Interval: Before each use or daily

Before starting the machine each day, perform the following procedures:

- Check the engine-oil level—refer to [Checking the Engine Oil \(page 30\)](#).
- Check the hydraulic-fluid level—refer to [Checking the Hydraulic-Fluid Level \(page 36\)](#).
- Check the reel-to-bedknife contact—refer to [Checking the Reel-to-Bedknife Contact \(page 43\)](#).
- Check the tire pressure—refer to [Checking the Tire Pressure \(page 33\)](#).

During Operation

During Operation Safety

General Safety

- The owner/operator can prevent and is responsible for accidents that may cause personal injury or property damage.
- Wear appropriate clothing, including eye protection; long pants; substantial, slip-resistant footwear; and hearing protection. Tie back long hair and do not wear loose clothing or loose jewelry.
- Do not operate the machine while ill, tired, or under the influence of alcohol or drugs.
- Use your full attention while operating the machine. Do not engage in any activity that causes distractions; otherwise, injury or property damage may occur.
- Before you start the engine, ensure that all drives are in neutral, the parking brake is engaged, and you are in the operating position.
- Do not carry passengers on the machine and keep bystanders and pets away from the machine during operation.
- Operate the machine only in good visibility to avoid holes or hidden hazards.
- Avoid mowing on wet grass. Reduced traction could cause the machine to slide.
- Keep your hands and feet away from the cutting units. Keep clear of the discharge opening at all times.

g227927

- Look behind and down before backing up to be sure of a clear path.
- Use care when approaching blind corners, shrubs, trees, or other objects that may obscure your vision.
- Stop the cutting units whenever you are not mowing.
- Slow down and use caution when making turns and crossing roads and sidewalks with the machine. Always yield the right-of-way.
- Disengage the drive to the cutting unit and shut off the engine before adjusting the height of cut (unless you can adjust it from the operating position).
- Never run an engine in an area where exhaust gasses are enclosed.
- Never leave a running machine unattended.
- Before leaving the operating position (including to empty the catchers or to unclog the cutting units), do the following:
 - Park the machine on level ground.
 - Disengage the power take-off and lower the attachments.
 - Engage the parking brake.
 - Shut off the engine and remove the key.
 - Wait for all moving parts to stop.
- surveying the site. Always use common sense and good judgment when performing this survey.
- Review the slope instructions, listed below, for operating the machine on slopes. Before you operate the machine, review the site conditions to determine whether you can operate the machine in the conditions on that day and at that site. Changes in the terrain can result in a change in slope operation for the machine.
 - Avoid starting, stopping, or turning the machine on slopes. Avoid making sudden changes in speed or direction. Make turns slowly and gradually.
 - Do not operate a machine under any conditions where traction, steering, or stability is in question.
 - Remove or mark obstructions such as ditches, holes, ruts, bumps, rocks, or other hidden hazards. Tall grass can hide obstructions. Uneven terrain could overturn the machine.
 - Be aware that operating the machine on wet grass, across slopes, or downhill may cause the machine to lose traction. Loss of traction to the drive wheels may result in sliding and a loss of braking and steering.
 - Use extreme caution when operating the machine near drop-offs, ditches, embankments, water hazards, or other hazards. The machine could suddenly roll over if a wheel goes over the edge or the edge caves in. Establish a safety area between the machine and any hazard.
 - Identify hazards at the base of the slope. If there are hazards, mow the slope with a pedestrian-controlled machine.
 - If possible, keep the cutting units lowered to the ground while operating on slopes. Raising the cutting units while operating on slopes can cause the machine to become unstable.
 - Use extreme caution with grass-collection systems or other attachments. These can change the stability of the machine and cause a loss of control.

Rollover Protection System (ROPS) Safety

- Do not remove the ROPS from the machine.
- Ensure that the seat belt is attached and that you can release it quickly in an emergency.
- Always wear your seat belt.
- Check carefully for overhead obstructions and do not contact them.
- Keep the ROPS in safe operating condition by thoroughly inspecting it periodically for damage and keeping all the mounting fasteners tight.
- Replace a damaged ROPS. Do not repair or alter it.

Slope Safety

- Slopes are a major factor related to loss of control and rollover accidents, which can result in severe injury or death. You are responsible for safe slope operation. Operating the machine on any slope requires extra caution.
- Evaluate the site conditions to determine if the slope is safe for machine operation, including

Breaking in the Machine

Refer to the engine manual supplied with the machine for oil change and maintenance procedures recommended during the break-in period.

Only 8 hours of operation is required for the break-in period.

Since the first hours of operation are critical to future dependability of the machine, monitor its functions and performance closely so that minor difficulties, which

could lead to major problems, are noted and can be corrected. Inspect the machine frequently during break-in for signs of oil leakage, loose fasteners, or any other malfunction.

Starting the Engine

Note: Inspect the areas beneath the cutting units to ensure that they are clear of debris.

1. Sit on the seat, engage the parking brake, disengage the raise/lower mow control and move the functional-control lever to the NEUTRAL position.
2. Ensure that the traction pedal is in the NEUTRAL position and that your foot is off the pedal.
3. If you are starting a cold engine, move the choke to the ON position.
4. Move the throttle lever to the HALF THROTTLE position.
5. Insert and rotate the ignition key clockwise until the engine starts.
6. After the engine starts, adjust the choke to run the engine smoothly. As soon as possible, open the choke by pulling it rearward to the OFF position. A warm engine requires little or no choking.

Checking the Machine after Starting the Engine

1. Move the throttle lever to the FAST position.
2. Move the raise/lower mow control lever forward momentarily.
The cutting units should lower and all the reels should rotate.
Note: The function lever should be in the middle (mow) position for the reels run when lowering the cutting units
3. Move the raise/lower mow control lever rearward.
The cutting reels should stop rotating and the cutting units should raise to the full transport position.
4. Engage the brake to keep the machine from moving, and operate the traction pedal through the forward and reverse positions.
5. Continue the above procedure for 1 or 2 minutes. Move the functional-control lever to the NEUTRAL position, engage the parking brake, and shut off the engine.
6. Check for fluid leaks and tighten the hydraulic fittings if any leaks are found.

Note: When the machine is new and the bearings and reels are tight, it is necessary to use the FAST throttle-lever position for this check. A fast throttle setting may not be required after the break-in period.

Note: If fluid leaks continue to appear, contact your authorized Toro distributor for assistance and, if necessary, replacement parts.

Important: A trace of fluid on the motor or wheel seals is normal. Seals require a small amount of lubrication to perform properly.

Shutting Off the Engine

1. Move the throttle lever to the SLOW position, pull back the raise/lower mow control, and move the functional-control lever to the NEUTRAL position.
2. Rotate the ignition key to the OFF position to shut off the engine. Remove the key from the switch to prevent accidental starting.
3. Close the fuel shut-off valve before storing the machine.

Checking the Safety-Interlock System

Service Interval: Before each use or daily

⚠ CAUTION

If the safety interlock switches are disconnected or damaged the machine could operate unexpectedly, causing personal injury.

- Do not tamper with the interlock switches.
- Check the operation of the interlock switches daily and replace any damaged switches before operating the machine.

The purpose of the safety-interlock system is to prevent operation of the machine where there is possible injury to you or damage to the machine.

The safety-interlock system prevents the engine from starting unless:

- The traction pedal is in the NEUTRAL position.
- The functional-control lever is in the NEUTRAL position.

The safety-interlock system prevents the machine from moving unless:

- The parking brake is disengaged.

- You are seated in the operator's seat.
- The functional-control lever is in the MOW position or the TRANSPORT position.

The safety-interlock system prevents the reels from operating unless the functional-control lever is in the MOW position.

Checking the Traction Pedal

Perform the following system checks daily to ensure that the interlock system is operating correctly:

1. Sit on the seat, move the traction pedal to the NEUTRAL position, move the functional-control lever to the NEUTRAL position, and engage the parking brake.
2. Try to move the traction pedal forward or backward.

The pedal should not move, which indicates that the interlock system is operating correctly. Correct the problem if it is not operating properly.

Checking the Function Control

1. Sit on the seat, move the traction pedal to the NEUTRAL position, move the functional-control lever to the NEUTRAL position, and engage the parking brake.
2. Move the functional-control lever to the MOW position or the TRANSPORT position and try to start the engine.

The engine should not turnover or start, which indicates that the interlock system is operating correctly. Correct the problem if it is not operating properly.

3. Sit on the seat, move the traction pedal to the NEUTRAL position, move the functional-control lever to the NEUTRAL position, and engage the parking brake.
4. Start the engine and move the functional-control lever to the MOW position or the TRANSPORT position.

The engine should shut off, which indicates that the interlock system is operating correctly.

Correct the problem if it is not operating properly.

Checking the Operator's Presence Switch

1. Sit on the seat, move the traction pedal to the NEUTRAL position, move the functional control lever to the NEUTRAL position, and engage the parking brake.
2. Start the engine.

3. Release the parking brake, move the functional control lever to the MOW position, and rise from the seat.

The engine should shut off, which indicates that the interlock system is operating correctly. Correct the problem if it is not operating properly.

Checking the Raise/Lower Mow Control

1. Sit on the seat, move the traction pedal to the NEUTRAL position, move the functional control lever to the NEUTRAL position, and engage the parking brake.
2. Start the engine.
3. Move the raise/lower mow control forward to lower the cutting units. The cutting units should lower but not start rotating.

If they start rotating, the interlock system is not operating correctly; correct the problem before operating the machine.

Driving the Machine without Mowing

- Ensure that the cutting units are fully raised.
- Move the functional-control lever to the TRANSPORT position.
- Use the brakes to slow the machine while going down steep hills to avoid loss of control.
- Always approach rough areas at a reduced speed and cross severe undulations carefully.
- Familiarize yourself with the width of the machine. Do not attempt to pass between objects that are close together to prevent costly damage and downtime.

Mowing the Green

Important: If the leak detector alarm (if equipped on your model) sounds or you notice an oil leak while cutting on a green, immediately raise the cutting units, drive directly off the green, and stop the machine in an area away from the green. Determine the cause of the leak and correct the problem.

Before mowing greens, find a clear area and practice performing basic machine functions (e.g., starting and stopping the machine, raising and lowering the cutting units, and turning).

Inspect the green for debris, remove the flag from the cup, and determine the best direction to mow.

Base the direction to mow on the previous mowing direction. Always mow in an alternate pattern from the previous mowing so that the grass blades are less apt to lay down and therefore be difficult to trap between the reel blades and the bedknife.

Cutting the Green

1. Approach the green with the functional-control lever in the MOW position and the throttle at full speed.
2. Start on 1 edge of the green so that you can use the ribbon procedure of cutting.

Note: This holds compaction to a minimum and leaves a neat, attractive pattern on the greens.

3. Push forward the raise/lower mow lever as the front edges of the grass baskets cross the outer edge of the green.

Note: This procedure drops the cutting units to the turf and starts the reels.

Important: The center cutting unit drops and raises slightly after the front cutting units do; therefore, you should practice gaining the required timing necessary to minimize the cleanup mowing operation.

Note: The delay in raising and lowering the center cutting unit depends on hydraulic fluid temperature. Cold hydraulic fluid results in a longer delay. As the fluid temperature increases, the delay time becomes shorter.

4. Overlap a minimal amount with the previous cut on return passes.

Note: To assist in maintaining a straight line across the green and keeping the machine an equal distance from the edge of the previous cut, imagine a sight line approximately 1.8 to 3 m (6 to 10 ft) ahead of the machine to the edge of the uncut portion of the green (Figure 24). Include the outer edge of the steering wheel as part of the sight line; i.e., keep the steering wheel edge aligned with a point that is always kept the same distance away from the front of the machine.

5. As the front edges of the baskets cross the edge of the green, pull back the raise/lower mow lever rearward and hold it until all the cutting units have risen. This stops the reels and lifts the cutting units.

Important: Time this step correctly so that you do not cut into the fringe area, yet cut as much of the green as possible to minimize the amount of grass left to mow around the outer periphery.

6. To cut down on operating time and to ease the lineup for the next pass, momentarily turn the

machine in the opposite direction, then turn it in the direction of the uncut portion. This movement is a tear-shaped turn (Figure 23), which quickly lines the machine up for your next pass.

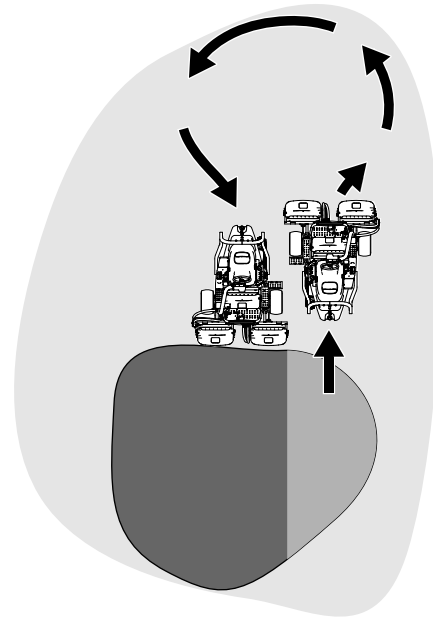

Figure 23

g229671

Note: Try to make as short of a turn as possible, except during warmer weather—a wider arc minimizes the turf bruising.

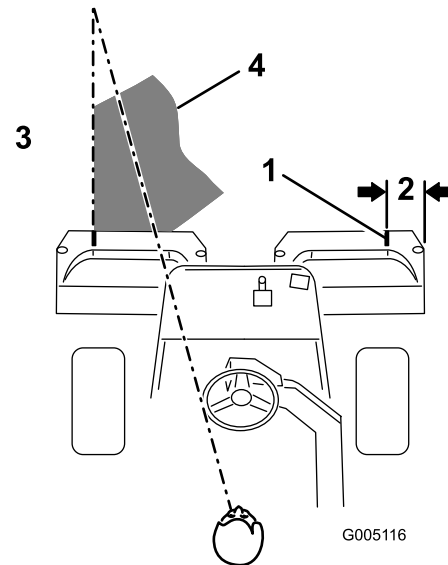

Figure 24

G005116

g005116

1. Alignment strip
2. Approximately 12.7 cm (5 inches)
3. Cut grass on the left.
4. Keep a focal spot 2 to 3 m (6 to 10 ft) ahead of the machine.

Note: The steering wheel does not return to its original position after you complete a turn.

Important: Never stop the machine on a green while the cutting units are engaged, as damage to the turf may result. Stopping the machine on a wet green may leave marks or indentations from the wheels.

Cutting the Periphery and Finishing the Job

1. Finish cutting the green by mowing the outer periphery. Change the direction of cutting from the previous mowing.

Note: Use the throttle lever to adjust the machine speed when you cut the periphery. This will match the clip to the green and may reduce triplex ring.

Note: Always keep weather and turf conditions in mind and be sure to change the direction of mowing from the previous cutting.

2. When finished mowing the outer periphery, tap the raise/lower mow lever rearward to stop the reels, then drive off the green. When all the cutting units are off the green, raise the cutting units.

Note: This step minimizes grass clumps left on the green.

3. Replace the flag.
4. Empty the grass baskets of all clippings before you transport the machine to the next green.

Note: Heavy wet clippings place an undue strain on the baskets and add unnecessary weight to the machine, which increases the load on the machine systems (e.g., engine, hydraulic system, and brakes).

After Operation

After Operation Safety

General Safety

- Always shut off the engine, remove the key (if equipped), wait for all moving parts to stop, and allow the machine to cool before adjusting, repairing, cleaning, or storing the machine.
- Clean grass and debris from the cutting units, drives, mufflers, cooling screens, and engine to help prevent fires. Clean up oil or fuel spills.
- Shut off the fuel while storing or transporting the machine.

- Disengage the drive to the attachment whenever you are transporting or not using the machine.
- Allow the engine to cool before storing the machine in any enclosure.
- Maintain and clean the seat belt(s) as necessary.
- Do not store the machine or fuel container where there is an open flame, spark, or pilot light, such as on a water heater or on other appliances.

Towing Safety

- Tow only with a machine that has a hitch designed for towing. Do not attach towed equipment except at the hitch point.
- Follow the manufacturer's recommendation for weight limits for towed equipment and towing on slopes. On slopes, the weight of the towed equipment may cause loss of traction and loss of control.
- Never allow children or others in or on towed equipment.
- Travel slowly and allow extra distance to stop when towing.

Inspecting and Cleaning after Mowing

After mowing, thoroughly wash the machine with a garden hose without a nozzle so that excessive water pressure does not contaminate and damage the seals and bearings. **Do not wash a warm engine or the electrical connections with water.**

After cleaning the machine, do the following:

- Inspect the machine for possible hydraulic fluid leaks, damage or wear to hydraulic and mechanical components.
- Inspect the cutting units for sharpness.
- Lubricate the brake-shaft assembly with SAE 30 oil or spray lubricant to deter corrosion and help keep the machine performing satisfactorily during the next mowing operation.

Hauling the Machine

- Use care when loading or unloading the machine into a trailer or a truck.
- Use a full-width ramp for loading the machine into a trailer or a truck.
- Tie the machine down securely using straps, chains, cable, or ropes. Both front and rear straps should be directed down and outward from the machine (Figure 25).

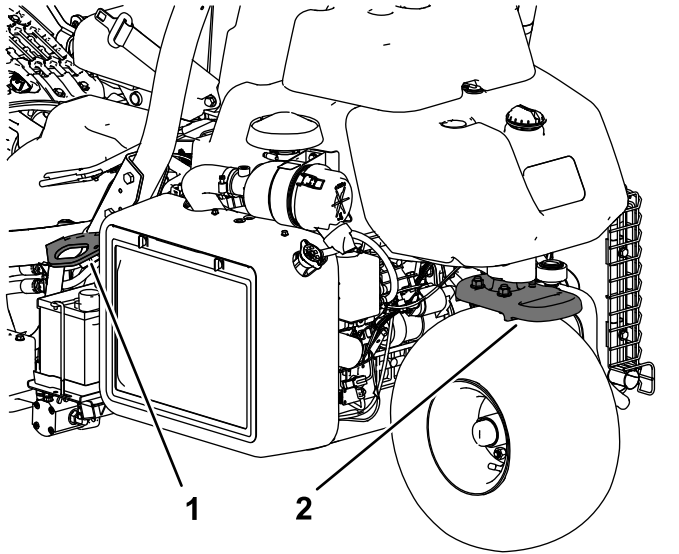

Figure 25

1. Tie-down loop (each side) 2. Rear tie-down loop

Towing the Machine

In case of an emergency, you can tow the machine for up to 0.4 km (1/4 mile).

Important: Do not tow the machine faster than 3 to 5 km/h (2 to 3 mph) to avoid damaging the drive system. If you must move the machine more than 0.4 km (1/4 mile), transport it on a truck or trailer.

1. Locate the bypass valve on the pump and rotate it so that the slot is vertical (Figure 26).

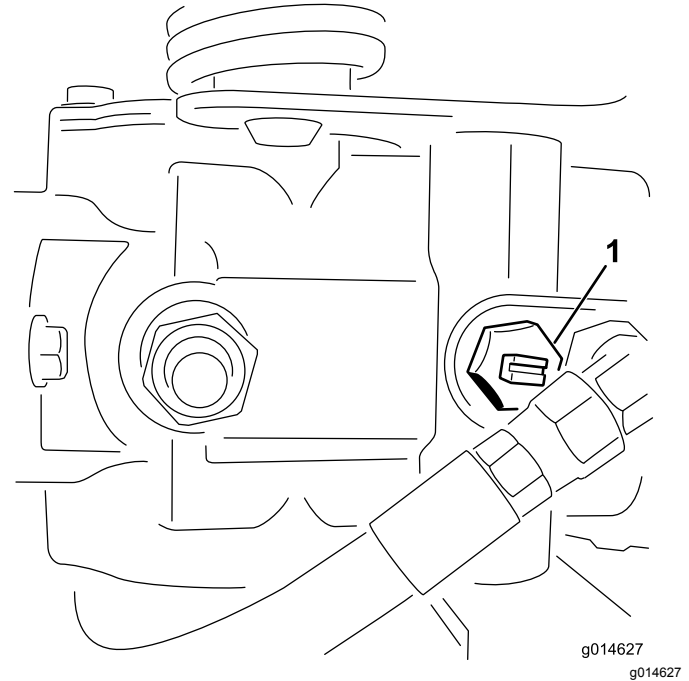

Figure 26

1. Bypass valve-slot shown in closed (horizontal) position
2. Before starting the engine, close the bypass valve by rotating it so that the slot is horizontal (Figure 26).

Important: Do not start the engine when the bypass valve is open.

Maintenance

⚠ CAUTION

Failure to properly maintain the machine could result in premature failure of machine systems causing possible harm to you or bystanders.

Keep the machine well maintained and in good working order as indicated in these instructions.

Note: Determine the left and right sides of the machine from the normal operating position.

Note: Download a free copy of the electrical or hydraulic schematic by visiting www.Exmark.com and searching for your machine from the Manuals link on the home page.

Important: Refer to your engine owner's manual for additional maintenance procedures.

⚠ WARNING

If you leave the key in the ignition switch, someone could accidentally start the engine and seriously injure you or other bystanders.

Remove the key from the ignition and disconnect the wires from the spark plugs before you do any maintenance. Set the wires aside so that they do not accidentally contact the spark plugs.

Recommended Maintenance Schedule(s)

Maintenance Service Interval	Maintenance Procedure
After the first hour	<ul style="list-style-type: none">• Torque the wheel nuts.
After the first 10 hours	<ul style="list-style-type: none">• Torque the wheel nuts.
After the first 25 hours	<ul style="list-style-type: none">• Change the engine oil and filter.
After the first 50 hours	<ul style="list-style-type: none">• Change the hydraulic-fluid filter.• Check the engine speed (at idle and full throttle).
Before each use or daily	<ul style="list-style-type: none">• Inspect the seat belt(s) for wear, cuts, and other damage. Replace the seat belt(s) if any component does not operate properly.• Check the safety-interlock system• Check the safety-interlock system.• Inspect and cleanup after mowing.• Check the engine oil.• Check the tire pressure.• Check the hydraulic-fluid level.• Check the hydraulic lines and hoses.• Check the reel-to-bedknife contact.
Every 50 hours	<ul style="list-style-type: none">• Service the air-cleaner foam element (more frequently when operating conditions are dusty or dirty).• Check the battery electrolyte level. (If the machine is in storage, check the electrolyte level every 30 days.)• Check the battery cable connections.
Every 100 hours	<ul style="list-style-type: none">• Service the air-cleaner paper element (more frequently when operating conditions are dusty or dirty).• Change the engine oil and filter.
Every 200 hours	<ul style="list-style-type: none">• Torque the wheel nuts.
Every 400 hours	<ul style="list-style-type: none">• Grease the machine.

Maintenance Service Interval	Maintenance Procedure
Every 800 hours	<ul style="list-style-type: none"> • Replace the spark plugs. • Replace the fuel filter (sooner if the fuel flow is restricted). • Change the hydraulic fluid, filter, and tank breather. • Check the engine speed (at idle and full throttle). • Check the valve clearance.
Every 2 years	<ul style="list-style-type: none"> • Check the fuel lines and connections. • Replace moving hoses.

Daily Maintenance Checklist

Duplicate this page for routine use.

Maintenance Check Item	For the week of:						
	Mon.	Tues.	Wed.	Thurs.	Fri.	Sat.	Sun.
Check the safety-interlock operation.							
Check the instrument operation							
Check the leak-detector alarm.							
Check the brake operation.							
Check the fuel level.							
Check the hydraulic-fluid level.							
Check the engine-oil level.							
Clean the engine, air-cooling fins.							
Inspect the air-filter pre-cleaner.							
Check any unusual engine noises.							
Check the reel-to-bedknife adjustment.							
Check the hydraulic hoses for damage.							
Check for fluid leaks.							
Check the tire pressure.							
Check the height-of-cut adjustment.							
Touch-up damaged paint.							

Notation for Areas of Concern		
Inspection performed by:		
Item	Date	Information

Pre-Maintenance Procedures

Maintenance Safety

- Before adjusting, cleaning, repairing, or leaving the machine, do the following:
 - Park the machine on a level surface.
 - Move the throttle switch to the low-idle position.
 - Disengage the cutting units.
 - Lower the cutting units.
 - Ensure that the traction is in neutral.
 - Engage the parking brake.
 - Shut off the engine and remove the key.
 - Wait for all moving parts to stop.
 - Allow machine components to cool before performing maintenance.
- If the cutting units are in the transport position, use the positive mechanical lock (if available) before you leave the machine unattended.
- If possible, do not perform maintenance while the engine is running. Keep away from moving parts.
- Use jack stands to support the machine or components when required.
- Carefully release pressure from components with stored energy.
- To ensure safe, optimal performance of the machine, use only genuine Toro replacement parts. Replacement parts made by other manufacturers could be dangerous, and such use could void the product warranty.

Engine Maintenance

Engine Safety

- Shut off the engine before checking the oil or adding oil to the crankcase.
- Do not change the governor speed or overspeed the engine.

Servicing the Air Cleaner

Service Interval: Every 50 hours—Service the air-cleaner foam element (more frequently when operating conditions are dusty or dirty).

Every 100 hours—Service the air-cleaner paper element (more frequently when operating conditions are dusty or dirty).

1. Clean the air-cleaner cover (Figure 27).

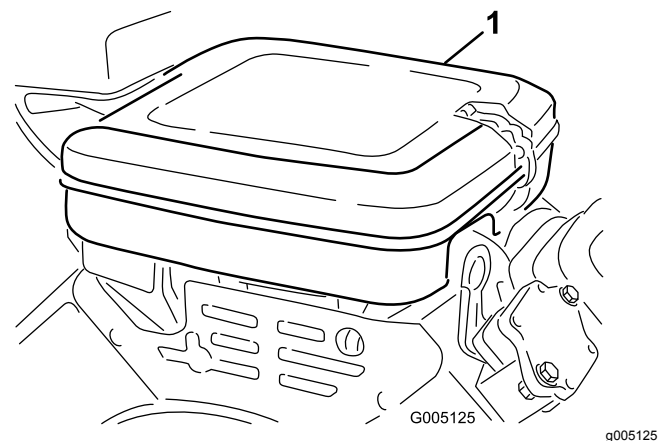

Figure 27

1. Air-cleaner cover

2. Release the locking clips and remove the air-cleaner cover.
3. Remove the wing nut securing the elements to the air-cleaner body (Figure 28).
4. If the foam element is dirty, remove it from the paper element (Figure 28). Clean it thoroughly, as follows:
 - A. Wash the foam element in a solution of liquid soap and warm water. Squeeze it to remove dirt.
 - B. Dry it by wrapping it in a clean rag. Squeeze the rag and foam element dry.

Important: When drying the foam element, do not twist it; the foam may tear.

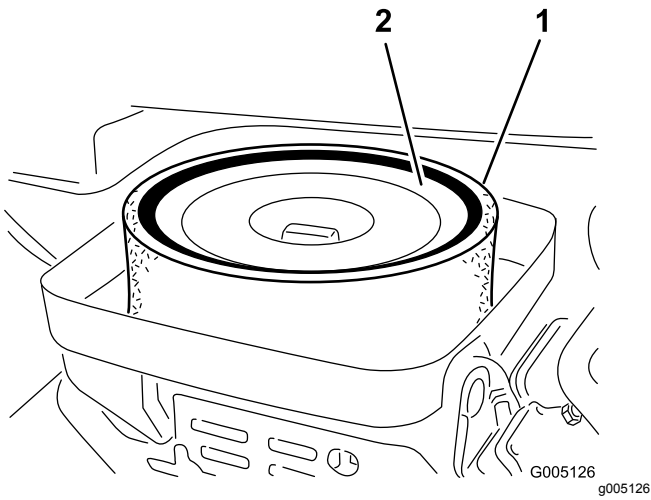

Figure 28

1. Foam element 2. Paper element

5. Check the condition of the paper element. Clean it by gently tapping it on a flat surface or replace it if needed.
6. Install the foam element, paper element, wing nut, and air-cleaner cover.

Important: Do not operate the engine without the air-cleaner element because extreme engine wear and damage will likely result.

Servicing the Engine Oil

The engine is shipped with oil in the crankcase; however, you must check the oil level before and after starting the engine the first time.

Engine Oil Specification

API Oil Service Classification: SJ or higher

Oil Viscosity: SAE 30

Note: Uses any high-quality detergent oil.

Checking the Engine Oil

1. Park the machine on a level surface, shut off the engine and remove the key.
2. Unscrew the dipstick, remove it, and wipe it with a clean rag.
3. Insert the dipstick into the dipstick tube and thread it into the tube (Figure 29).

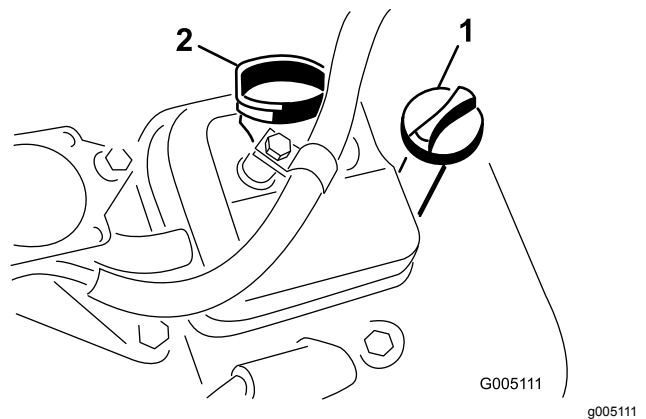

Figure 29

1. Dipstick 2. Filler cap

4. Unscrew the dipstick, pull it out of the tube, and check the oil level.
5. If the oil level is low, remove the filler cap from the valve cover and add oil into the engine through the filler neck until the oil level is up to the FULL mark on the dipstick.

Add the oil slowly and check the level often during this process.

Important: Do not overfill the engine with oil.

6. Install the filler cap and dipstick.

Changing the Engine Oil and Filter

Service Interval: After the first 25 hours

Every 100 hours

Engine oil quantity: 1.65 L (1-3/4 US qt) with filter

1. Remove the drain plug (Figure 30) and let the oil flow into a drain pan.

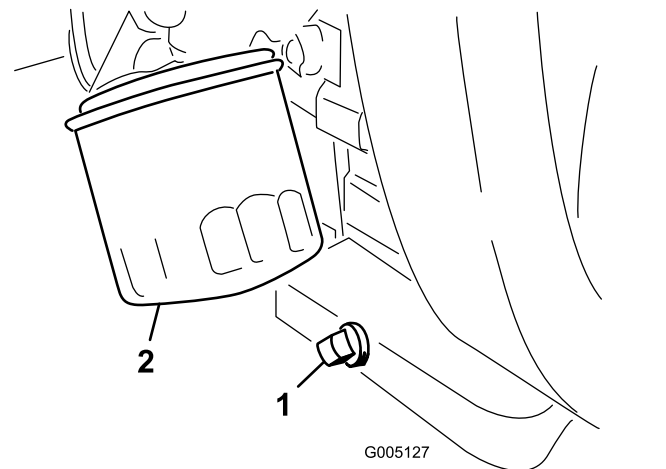

Figure 30

1. Drain plug 2. Oil filter

- Clean the threads of the drain plug, apply PTFE sealant, and install the drain plug (Figure 30).
- Remove the oil filter (Figure 30).
- Apply a light coat of clean oil to the new filter gasket.
- Screw the filter on by hand until the gasket contacts the filter adapter, then tighten it 3/4 to 1 turn further. **Do not overtighten it.**
- Add oil to the crankcase; refer to [Engine Oil Specification \(page 30\)](#) and [Checking the Engine Oil \(page 30\)](#).
- Dispose of the oil filter and used oil properly.

Replacing the Spark Plugs

Service Interval: Every 800 hours

Spark plug specification: Champion RC 14YC

Air gap specification: 0.76 mm (0.030 inch)

- Clean the area around the spark plugs so that foreign matter cannot fall into the cylinder.
- Pull the wires off the spark plugs and remove the plugs.
- Check the condition of the side electrode, center electrode, and center electrode insulator to ensure that there is no damage.

Important: Replace a cracked, fouled, dirty, or otherwise malfunctioning spark plug. Do not sand blast, scrape, or clean electrodes by using a wire brush because grit may eventually release from the plug, fall into the cylinder, and damage the engine.

- Set the air gap between the center and side of the electrodes at 0.76 mm (0.030 inches) as shown in Figure 31.

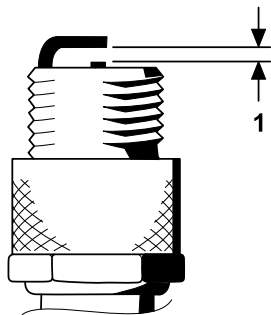

Figure 31

- Set air gap to 0.76 mm (0.030 inches).
- Install the spark plug and gasket seal, and torque the plug to 23 N·m (200 in-lb).

Fuel System Maintenance

Replacing the Fuel Filter

Service Interval: Every 800 hours (sooner if the fuel flow is restricted).

The in-line fuel filter is in the fuel line between the fuel tank and carburetor (Figure 32).

⚠ DANGER

In certain conditions, fuel is extremely flammable and highly explosive. A fire or explosion from fuel can burn you and others and can damage property.

- Drain fuel from the fuel tank when the engine is cold. Do this outdoors in an open area. Wipe up any fuel that spills.
- Never smoke when draining fuel, and stay away from an open flame or where a spark may ignite the fumes.

- Close the fuel-shutoff valve (Figure 32).

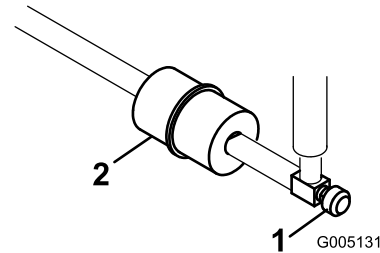

Figure 32

- Fuel-shutoff valve
- Fuel filter

- Place a drain pan under the filter, loosen the hose clamp on the carburetor side of filter, and remove the fuel line from the filter (Figure 32).
- Loosen the other hose clamp and remove the filter (Figure 32).
- Install the new filter with the arrow on the filter body pointing away from the fuel tank.

Inspecting the Fuel Lines and Connections

Service Interval: Every 2 years

Inspect the fuel lines for deterioration, damage, or loose connections.

Electrical System Maintenance

Electrical System Safety

- Disconnect the battery before repairing the machine. Disconnect the negative terminal first and the positive last. Connect the positive terminal first and the negative last.
- Charge the battery in an open, well-ventilated area, away from sparks and flames. Unplug the charger before connecting or disconnecting the battery. Wear protective clothing and use insulated tools.

Servicing the Battery

Service Interval: Every 50 hours (If the machine is in storage, check the electrolyte level every 30 days.)

Properly maintain the battery electrolyte and keep the top of the battery clean. Store the machine in a cool place to prevent the battery from running down.

The battery cables must be tight on the terminals to provide good electrical contact.

⚠ DANGER

Battery electrolyte contains sulfuric acid, which can be fatal if consumed and causes severe burns.

- **Do not drink electrolyte and avoid contact with skin, eyes or clothing. Wear safety glasses to shield your eyes and rubber gloves to protect your hands.**
- **Fill the battery where clean water is always available for flushing the skin.**

1. Check the electrolyte level in the cells of the battery.
2. If needed, add distilled or demineralized water into the cell of the battery.

Note: Only raise the electrolyte level to the bottom of the split ring inside each cell.

3. Clean the top of the battery by washing it periodically with a brush dipped in ammonia or bicarbonate of soda solution.
4. Flush the top surface of the battery with water after cleaning it.

Important: Do not remove the fill caps while cleaning the battery.

⚠ WARNING

Incorrect battery cable routing could damage the tractor and cables, causing sparks. Sparks can cause the battery gasses to explode, resulting in personal injury.

- **Always disconnect the negative (black) battery cable before disconnecting the positive (red) cable.**
- **Always connect the positive (red) battery cable before connecting the negative (black) cable.**

If corrosion occurs at the terminals, disconnect the cables, negative (-) cable first, and scrape the clamps and terminals separately. Connect the cables, positive (+) cable first, and coat the terminals with petroleum jelly.

Locating the Fuses

The fuses in the electrical system are located under the seat (Figure 33).

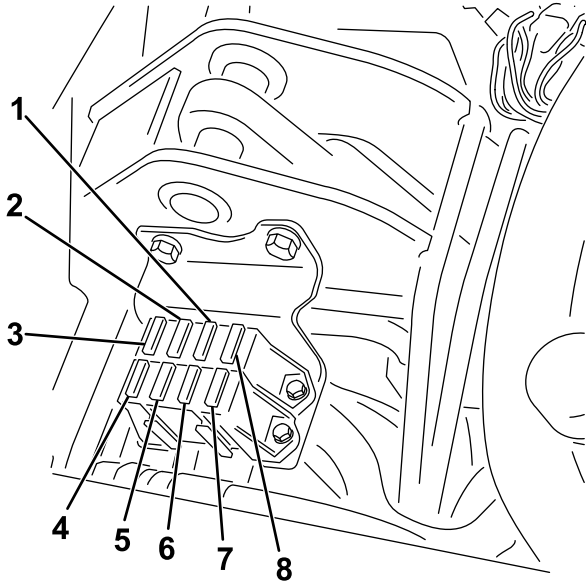

Figure 33

g195277

- | | |
|--|----------------------------------|
| 1. Start/run, Diagnostic lights, and leak detector—7.5 A | 5. No fuse |
| 2. Reel engage and lift/lower—7.5 A | 6. Lights and leak detector—15 A |
| 3. Lift reel and E-reel enable—7.5 A | 7. Run—10 A |
| 4. Hydraulic fan kit (optional)—15 A | 8. ECM logic and power—2 A |

Drive System Maintenance

Checking the Tire Pressure

Service Interval: Before each use or daily

Vary the tire pressure for all 3 wheels, depending upon your turf conditions, from a minimum of 83 to a maximum of 110 kPa (12 psi to 16 psi).

Checking the Torque of the Wheel Nuts

Service Interval: After the first hour

After the first 10 hours

Every 200 hours

⚠ WARNING

Failure to maintain proper torque of the wheel nuts could result in personal injury.

Torque the wheel nuts to the specified torque at the specified intervals.

Wheel nut torque specification: 95 to 122 N·m (70 to 90 ft-lb)

Note: To ensure even distribution, torque the wheel nuts in a X pattern.

Adjusting the Transmission for Neutral

If the machine creeps when the traction-control pedal is in the NEUTRAL position, adjust the neutral-return mechanism.

1. Ensure that the bypass valve is closed.
2. Lift the machine and support it at the frame so that 1 of the front wheels is off the floor.

Note: If the machine is equipped with a 3-Wheel Drive Kit, also raise and block the rear wheel.

3. Start the engine, move the throttle to the SLOW position, and ensure that the front wheel that is off the floor is not rotating.
4. If the wheel is rotating, shut off the engine and proceed as follows:
 - A. Loosen the nut securing the eccentric to the top of the hydrostat (Figure 34).

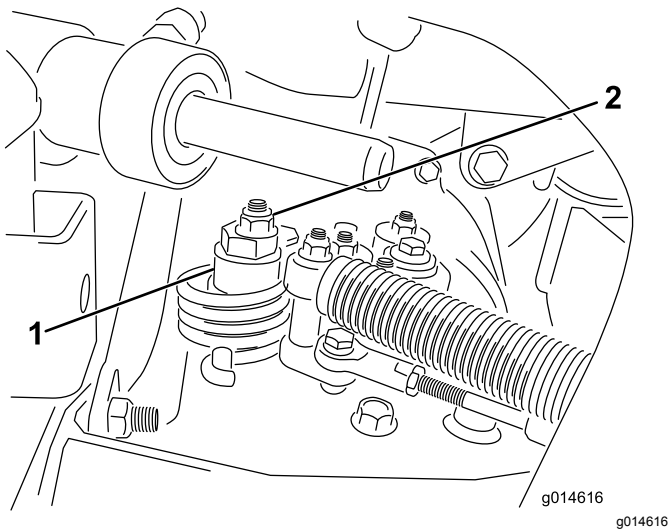

Figure 34

1. Eccentric 2. Locknut

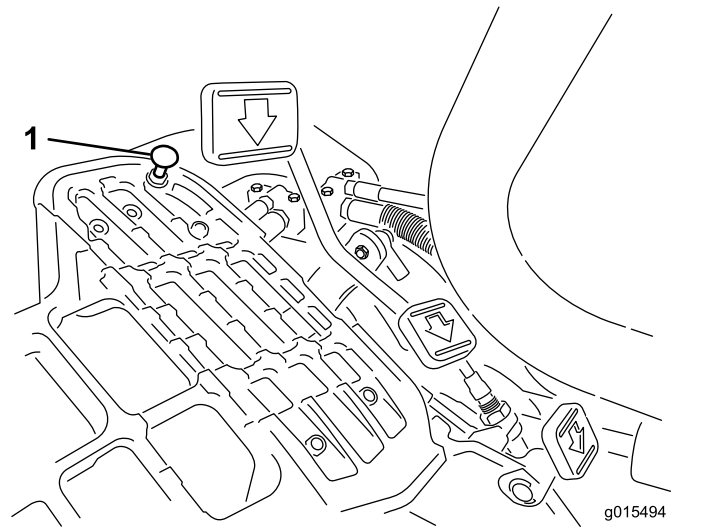

Figure 35

1. Pedal stop

- B. Move the functional-control lever to the NEUTRAL position and the throttle to the SLOW position. Start the engine.
- C. Rotate the eccentric until creep does not occur in either direction. When the wheel stops rotating, tighten the nut locking the eccentric and the adjustment (Figure 34). Verify the adjustment with the throttle in the SLOW and FAST position.

Note: If the wheel still turns when the eccentric is at the maximum adjustment, contact your authorized Toro distributor or refer to the *Service Manual* for further adjustment.

Adjusting the Transport Speed

Obtaining the Maximum Transport Speed

The traction pedal comes adjusted for maximum-transport speed, but you may need to adjust it if the pedal reaches full stroke before it contacts the pedal stop, or if you want to a decrease the transport speed.

To obtain the maximum-transport speed, put the functional control lever in the TRANSPORT position and press down on the traction pedal. If the pedal contacts the stop (Figure 35) before you feel tension on the cable, perform the following adjustment procedure:

1. Put the functional-control lever in the TRANSPORT position and loosen the locknut securing the pedal stop to the floor plate (Figure 35).
2. Tighten the pedal stop until it does not contact the traction pedal.
3. Continue applying a light load on the transport pedal and adjust the pedal stop so it contacts the pedal rod and tighten the nuts.

Important: Ensure that the tension on the cable is not excessive or you will reduce the cable life.

Reducing the Transport Speed

1. Press down on the traction pedal and loosen the locknut securing the pedal stop to the floor plate.
2. Loosen the pedal stop until you obtain the desired transport speed.
3. Tighten the locknut securing the pedal stop.

Adjusting the Mowing Speed

The mow speed is set to 3.8 mph at the factory.

You can adjust the forward moving speed from 0 to 8 km/h (0 to 5 mph).

1. Loosen the jam nut on the trunnion bolt (Figure 36).
2. Loosen the nut securing the lock and mow brackets on the pedal pivot.

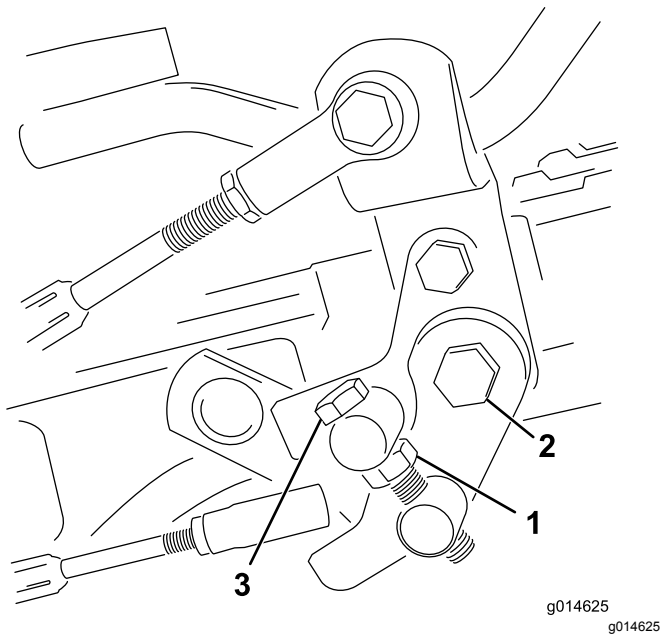

Figure 36

1. Jam nut
2. Nut
3. Trunnion bolt

3. Rotate the trunnion bolt clockwise to reduce the mowing speed and counterclockwise to increase the mowing speed.
4. Tighten the jam nut on the trunnion bolt and the nut on the pedal pivot to lock the adjustment (Figure 36). Check the adjustment and adjust as required.

Brake Maintenance

Burnishing the Brakes

Firmly apply the brakes and drive the machine at mowing speed until the brakes are hot, as indicated by their smell. You may need to adjust the brakes after the break-in period; refer to [Adjusting the Brakes](#) (page 35).

Adjusting the Brakes

If the brake fails to hold the machine while parked, you can adjust the brakes using the bulkhead fitting near the brake drum; contact your Authorized Service Dealer or refer to the *Service Manual* for more information.

Note: Burnish the brakes annually; refer to [Burnishing the Brakes](#) (page 35).

Hydraulic System Maintenance

Hydraulic System Safety

- Seek immediate medical attention if fluid is injected into skin. Injected fluid must be surgically removed within a few hours by a doctor.
- Ensure that all hydraulic-fluid hoses and lines are in good condition and all hydraulic connections and fittings are tight before applying pressure to the hydraulic system.
- Keep your body and hands away from pinhole leaks or nozzles that eject high-pressure hydraulic fluid.
- Use cardboard or paper to find hydraulic leaks.
- Safely relieve all pressure in the hydraulic system before performing any work on the hydraulic system.

Servicing the Hydraulic Fluid

Important: Regardless of the hydraulic fluid type used, any traction unit used for off-green applications, verticutting or used during ambient temperatures above 29°C (85°F) should have the Oil Cooler Kit installed; refer to [5 Installing the Oil Cooler \(page 12\)](#).

Hydraulic Fluid Specifications

The recommended replacement fluid is as follows:

Toro Premium All Season Hydraulic Fluid (Available in 5-gallon pails or 55-gallon drums. See parts catalog or Toro distributor for part numbers.)

Alternate fluids: If the Toro fluid is not available, other fluids may be used provided they meet all the following material properties and industry specifications. We do not recommend the use of synthetic fluid. Consult with your lubricant distributor to identify a satisfactory product

Note: Toro will not assume responsibility for damage caused by improper substitutions, so use only products from reputable manufacturers who will stand behind their recommendation.

High Viscosity Index/Low Pour Point Anti-wear Hydraulic Fluid, ISO VG 46	
Material Properties:	
Viscosity, ASTM D445	cSt @ 40° C 44 to 50 cSt @ 100° C 7.9 to 8.5

Viscosity Index ASTM D2270	140 to 160
Pour Point, ASTM D97	-34° F to -49° F
Industry Specifications:	
Vickers I-286-S (Quality Level), Vickers M-2950-S (Quality Level), Denison HF-0	

Important: The ISO VG 46 Multigrade fluid has been found to offer optimal performance in a wide range of temperature conditions. For operation in consistently high ambient temperatures, 18°C (65°F) to 49°C (120°F), ISO VG 68 hydraulic fluid may offer improved performance.

Premium Biodegradable Hydraulic Fluid-Mobil EAL EnviroSyn 46H

Important: Mobil EAL EnviroSyn 46H is the only synthetic biodegradable fluid approved by Toro. This fluid is compatible with the elastomers used in Toro hydraulic systems and is suitable for a wide-range of temperature conditions. This fluid is compatible with conventional mineral oils, but for maximum biodegradability and performance the hydraulic system should be thoroughly flushed of conventional fluid. The fluid is available in 19 L (5 gallon) containers or 55 gallon drums from your Mobil Distributor.

Important: Many hydraulic fluids are almost colorless, making it difficult to spot leaks. A red dye additive for the hydraulic system fluid is available in 20 ml (2/3 oz) bottles. One bottle is sufficient for 15 to 22 L (4 to 6 gallons) of hydraulic fluid. Order Part No. 44-2500 from your authorized Toro distributor. *This red dye is not recommended for use with biodegradable fluids. Use food coloring.*

Checking the Hydraulic-Fluid Level

The hydraulic-fluid reservoir is filled at the factory with high quality hydraulic fluid. Before operating the machine each day, check the level of the hydraulic fluid. Your machine has a dipstick or a white plastic window on the front of the hydraulic-fluid reservoir (behind the seat on the left side) that is used to check the hydraulic-fluid level. The fluid should be between the window lines or the dipstick marks; if not, add the appropriate fluid.

Important: To prevent system contamination, clean the top of the hydraulic fluid containers before puncturing them. Ensure that the pour spout and funnel are clean.

1. Position the machine on a level surface.

Note: Ensure that the machine has cooled down so the fluid is cold.

2. Check the fluid level according to the tank on your machine:

- If your machine has a fuel gauge at the top of the fuel tank, locate the dipstick for the hydraulic system at the top of the leak detector tank (Figure 37) and proceed to step 3.

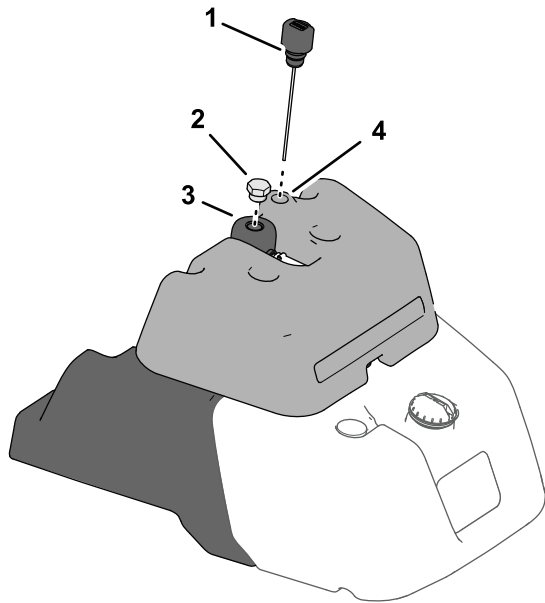

Figure 37

g228585

- | | |
|------------------------|-----------------------|
| 1. Dipstick | 3. Hydraulic tank |
| 2. Hydraulic tank plug | 4. Leak-detector tank |

- If your machine has a fuel sight gauge at the side of the fuel tank, locate the dipstick for the hydraulic system at the top of the hydraulic tank (Figure 38) and proceed to step 5.

Note: If the fluid level is between the 2 marks on the sight window, the fluid level is sufficient.

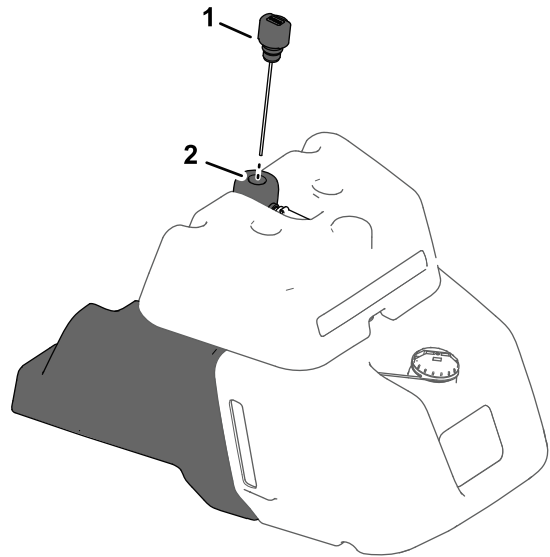

Figure 38

g228586

- | | |
|-------------|-------------------|
| 1. Dipstick | 2. Hydraulic tank |
|-------------|-------------------|

3. Remove the dipstick and wipe it with a clean rag, then screw the dipstick back into the tank.
4. Remove the dipstick and check the fluid level. If the fluid is between the marks on the dipstick, the level is sufficient. If the fluid level is not between the marks, more fluid is needed.
5. Remove the cap from the hydraulic fluid tank and slowly fill the tank with the appropriate high-quality hydraulic fluid until the level is between the 2 marks on the sight window or dipstick.

Note: Do not mix different types of hydraulic fluid.

6. Install the cap.

Note: Perform a close visual inspection of the hydraulic components. Inspect them for issues (e.g., leaks, loose fasteners, missing parts, and improperly routed lines). Make any necessary corrections.

Changing the Hydraulic Fluid and Filter

Service Interval: After the first 50 hours

Every 800 hours

Hydraulic Fluid Capacity: 25.7 L (6.8 US gallons)

If the fluid becomes contaminated, have your authorized Toro distributor flush the system. Contaminated fluid looks milky or black when compared to clean fluid.

1. Clean the area around the filter mounting area (Figure 39). Place a drain pan under the filter and remove the filter.

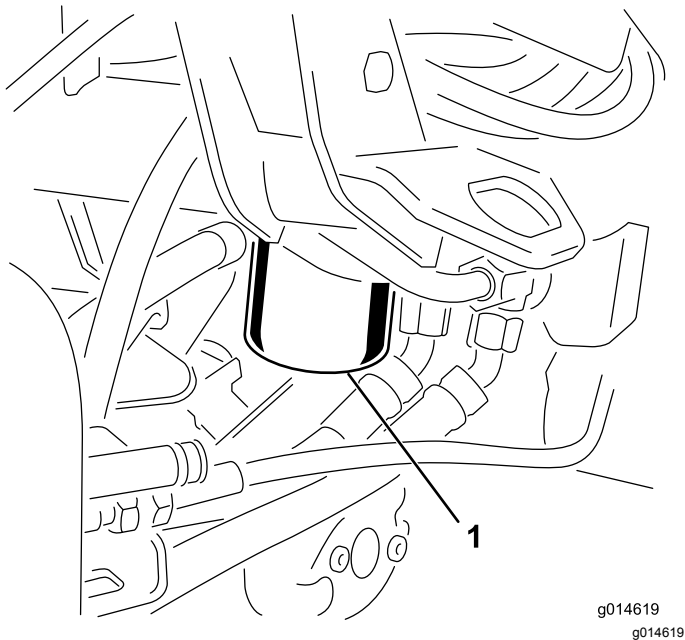

Figure 39

1. Hydraulic-fluid filter

Note: If you will not be draining the fluid, disconnect and plug the hydraulic line going to the filter.

2. Fill the replacement filter with the appropriate hydraulic fluid, lubricate the sealing gasket, and hand turn it until the gasket contacts the filter head. Then tighten it 3/4 turn further.
3. Fill the hydraulic reservoir with hydraulic fluid; refer to [Hydraulic Fluid Specifications \(page 36\)](#) and [Checking the Hydraulic-Fluid Level \(page 36\)](#).
4. Start the machine and run it at idle for 3 to 5 minutes to circulate the fluid and remove any air trapped in the system. Shut off the engine and check the fluid level.
5. Dispose of the fluid and filter properly.

Checking the Hydraulic Lines and Hoses

⚠ WARNING

Hydraulic fluid escaping under pressure can penetrate skin and cause injury.

- Ensure that all hydraulic fluid hoses and lines are in good condition and all hydraulic connections and fittings are tight before applying pressure to the hydraulic system.
- Keep your body and hands away from pinhole leaks or nozzles that eject high-pressure hydraulic fluid.
- Use cardboard or paper to find hydraulic leaks.
- Safely relieve all pressure in the hydraulic system before performing any work on the hydraulic system.
- Get immediate medical help if fluid is injected into skin.

Check the hydraulic lines and hoses daily for leaks, kinked lines, loose mounting supports, wear, loose fittings, weather deterioration, and chemical deterioration. Make all necessary repairs before operating.

Checking the Leak Detector

The leak detector system is designed to assist in early detection of hydraulic-fluid-system leaks. If the fluid level in the main hydraulic reservoir is lowered by 118 to 177 ml (4 to 6 oz), the float switch in the tank will close. After a 1 second delay, the alarm sounds, alerting the operator (Figure 42). Expansion of fluid, due to normal heating during machine operation, causes the fluid to transfer into the auxiliary fluid reservoir. The fluid returns to the main tank when you turn off the ignition switch.

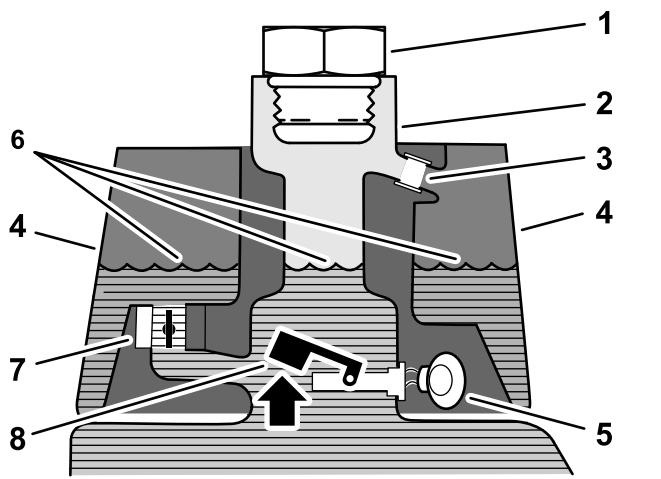

g229108

Figure 40

Before Starting (fluid cold)

- | | |
|-----------------------|---------------------------------|
| 1. Filler plug | 5. Warning buzzer—no sound |
| 2. Filler neck | 6. Fluid level (cold) |
| 3. Overflow tube | 7. Solenoid-return valve (open) |
| 4. Leak-detector tank | 8. Float switch (raised—open) |

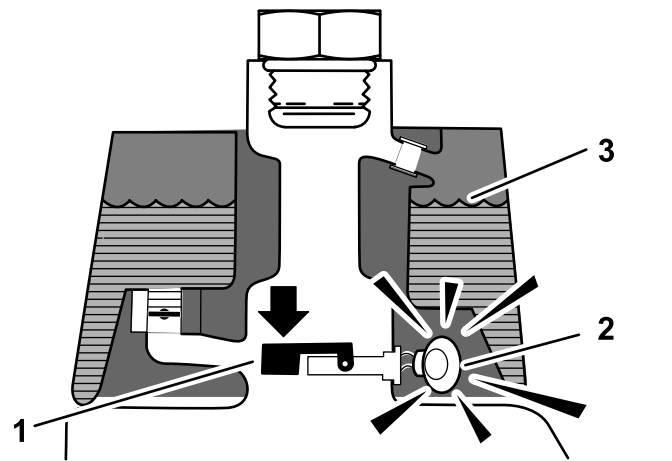

g229110

Figure 42

Leak Alert!

- | | |
|---|-----------------------|
| 1. Float switch (down—closed)
Fluid level down 118 to 177 ml (4 to 6 oz) | 3. Fluid level (warm) |
| 2. Warning buzzer | |

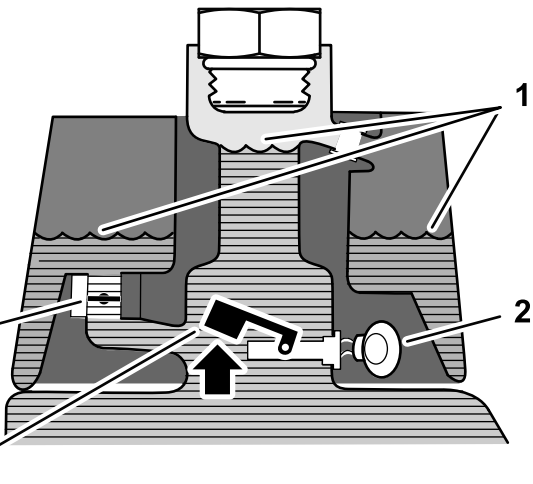

g229109

Figure 41

Normal Operation (fluid warm)

- | | |
|-----------------------------------|-------------------------------|
| 1. Fluid level (warm) | 3. Warning buzzer |
| 2. Solenoid-return valve (closed) | 4. Float switch (raised—open) |

Checking the System Operation

1. With ignition switch in the ON position, move the leak detector switch rearward and hold. After the 1-second delay elapses, the alarm should sound.
2. Release the leak-detector switch.

Checking the Leak-Detector-System Operation

1. Move the ignition switch to the ON position. Do not start the engine.
2. Remove the hydraulic-tank cap from the neck of the tank.
3. Insert a clean rod or screwdriver into the tank neck and gently push down on the float switch (Figure 43); the alarm should sound after the 1-second delay.

Cutting Unit Maintenance

Blade Safety

Refer to and complete the procedure in [Maintenance \(page 27\)](#). A worn or damaged blade or bedknife can break, and a piece could be thrown toward you or bystanders, resulting in serious personal injury or death.

- Inspect the blades and bedknives periodically for excessive wear or damage.
- Use care when checking the blades. Wear gloves and use caution when servicing them. Only replace or backlap the blades and bedknives; never straighten or weld them.
- On machines with multiple cutting units, take care when rotating a reel; it can cause the reels in the other cutting units to rotate.

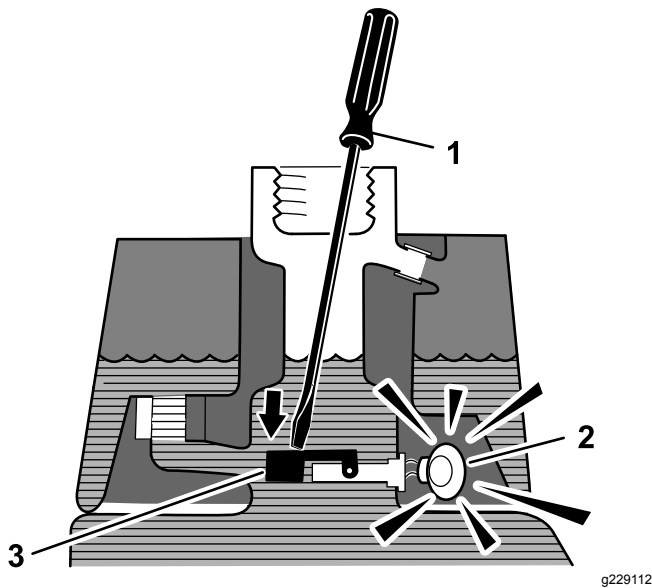

Figure 43

1. Clean rod or screwdriver
 2. Warning buzzer
 3. Press down on the float switch
-
4. Release the float; the alarm should stop sounding.
 5. Install the hydraulic-tank cap.
 6. Move the ignition switch to the OFF position.

Operating the Leak Detector

The leak detector alarm may sound for 1 of the following reasons:

- A leak of 118 to 177 ml (4 to 6 oz) has occurred.
- The fluid level in the main reservoir is reduced by 118 to 177 ml (4 to 6 oz) due to contraction of the fluid by cooling.

If the alarm sounds, turn off the machine as quickly as possible and inspect it for leaks. If the alarm sounds while operating on a green, drive off the green first. Determine the source of the leak and repair it before continuing operation.

If you do not find a leak and suspect a false alarm, move the ignition switch to the OFF position and allow the machine to stand for 1 to 2 minutes to allow the fluid levels to stabilize. Then start the machine and operate it in a non-sensitive area to confirm that no leak exists.

False alarms, due to fluid contraction, may be caused by extended idling of the machine after normal operation. A false alarm may also occur if you work the machine at a reduced workload after an extended period of a heavier workload. To avoid false alarms, turn the machine off rather than idling for extended periods.

Installing and Removing the Cutting Units

⚠ CAUTION

The cutting-unit blades are sharp and can cut your hands.

Wear heavy leather or cut-resistant gloves when handling the cutting units.

Note: When sharpening, setting the height of cut, or performing other maintenance procedures on the cutting units, store the cutting unit reel motors in the storage location on the front of the suspension arms to prevent damage to them.

Important: Do not raise the suspension to the transport position when the reel motors are in the holders in the machine frame. Damage to the motors or hoses could result.

Important: Whenever you need to tip the cutting unit, prop up the rear of the cutting unit to ensure that the nuts on the bedbar adjusting screws are not resting on the work surface ([Figure 44](#)).

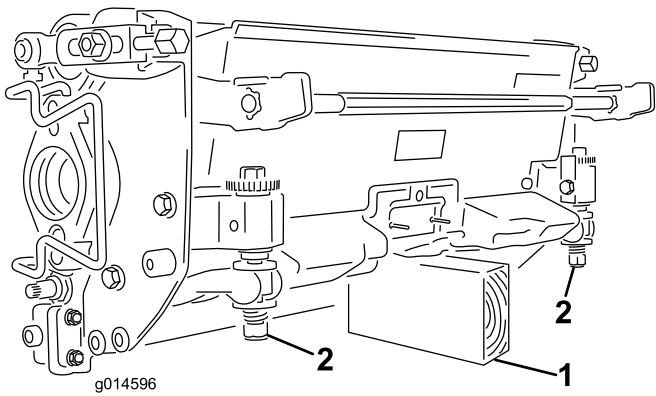

Figure 44

1. Prop (not provided)
2. Bedbar-adjusting-screw nut (2)

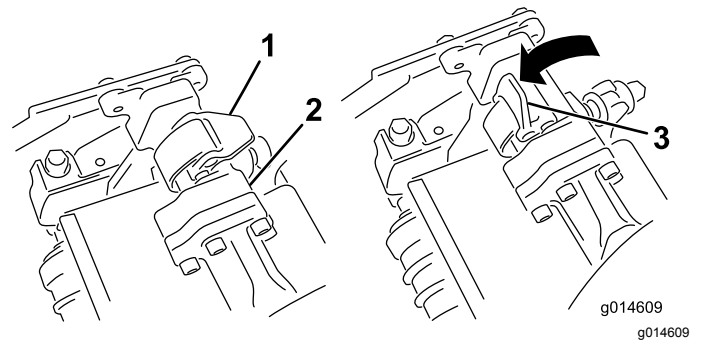

Figure 46

1. Latch—closed position
2. Suspension-arm bar
3. Latch—open position

Installing the Cutting Units

1. Lift up on the footrest and swing it open, allowing access to the center cutting unit position (Figure 45).

CAUTION

The footrest can pinch fingers if it falls into the closed position.

Keep your fingers clear of the area where the footrest seats while it is open.

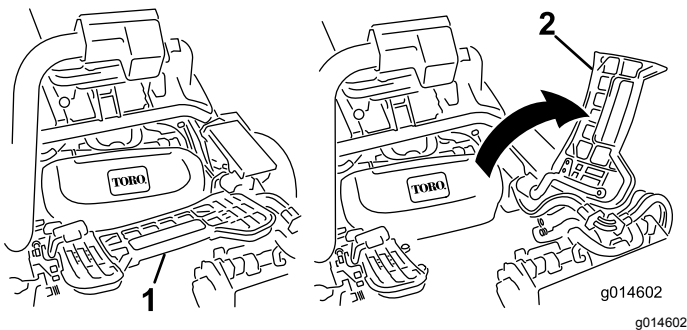

Figure 45

1. Footrest—closed
2. Footrest—open

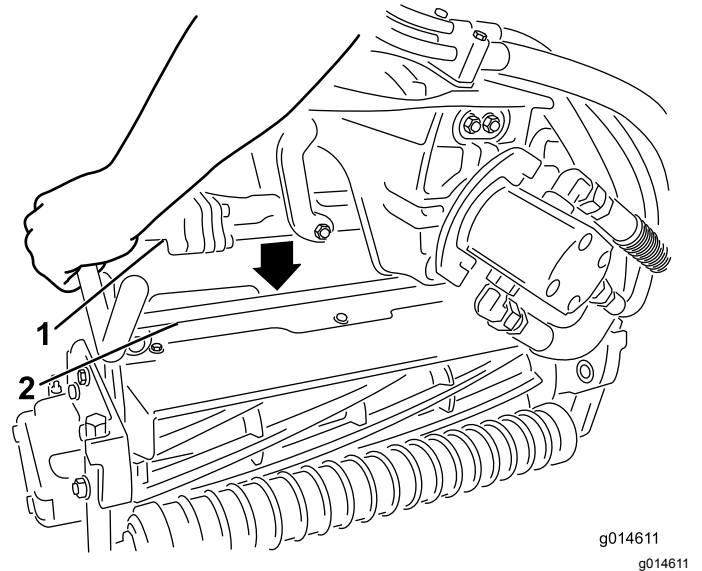

Figure 47

1. Suspension-arm bar
2. Cutting-unit bar

4. Close the latches down and around the cutting-unit bar and lock them in place (Figure 46).

Note: You can hear a click and feel when the latches are properly locked in place.

2. Position the cutting unit under the center suspension arm.
3. With the latches on the suspension-arm bar pointing up (i.e., open) (Figure 46), push the suspension arm down so that the bar fits over the bar across the top of the cutting unit (Figure 47).

5. Coat the spline shaft of the cutting unit motor with clean grease (Figure 48).
6. Insert the motor into the left side of the cutting unit (as viewed from the operator's position) and pull the motor retaining bar on the cutting unit toward the motor until you hear a click from both sides of the motor (Figure 48).

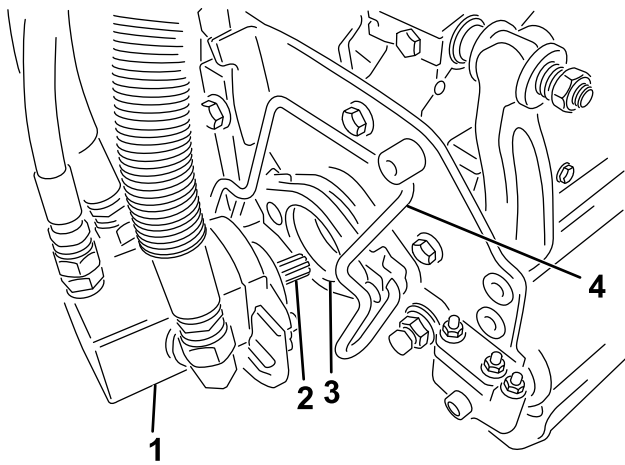

Figure 48

- | | |
|-----------------|------------------------|
| 1. Reel motor | 3. Cavity |
| 2. Spline shaft | 4. Motor-retaining bar |

7. Mount a grass basket onto the basket hooks on the suspension arm.
8. Repeat this procedure for the other cutting units.

Removing the Cutting Units

1. Park the machine on a clean level surface, lower the cutting units to the ground until the suspension hydraulics are fully extended, shut off the engine, and set the parking brake.
2. Push the motor retaining bar out of the slots on the motor toward the cutting unit and remove the motor from the cutting unit.

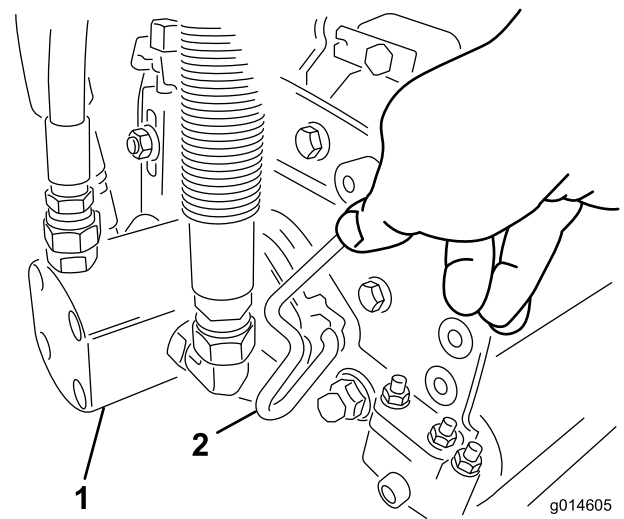

Figure 49

- | | |
|---------------|------------------------|
| 1. Reel motor | 2. Motor-retaining bar |
|---------------|------------------------|

3. Move the motor to the storage location on the front of the suspension arm (Figure 50).

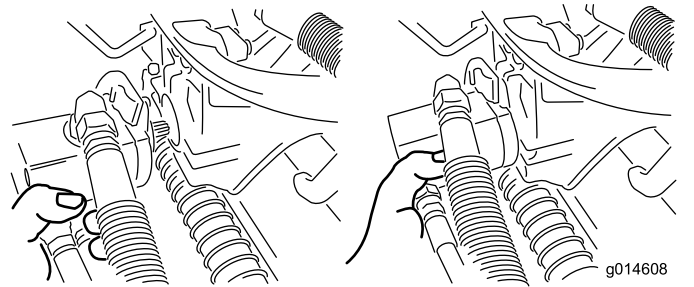

Figure 50

Note: When sharpening, setting the height of cut, or performing other maintenance procedures on the cutting units, store the cutting unit reel motors in the storage location on the front of the suspension arms to prevent damage to them.

Important: Do not raise the suspension to the transport position when the reel motors are in the holders in the machine frame. Damage to the motors or hoses could result. If you must move the traction unit without the cutting units installed, secure them to the suspension arms using cable ties.

4. Open the latches on the suspension-arm bar of the cutting unit you are removing (Figure 46).
5. Disconnect the latches from the cutting-unit bar.
6. Roll the cutting unit out from under the suspension arm.
7. Repeat steps 2 through 6 for the other cutting units as required.

Checking the Reel-to-Bedknife Contact

Each day before operating the machine, check the reel-to-bedknife contact, regardless if the quality of cut had previously been acceptable. There must be light contact across the full length of the reel and bedknife; refer to the Cutting Unit *Operator's Manual*.

Setting the Reel Speed

To achieve a consistent, high-quality cut and a uniform after-cut appearance, you must correctly set the reel speed control (located on the manifold block under the cover to the left of the seat). Adjust the reel speed control as follows:

1. Select the height of cut at which the cutting units are set.
2. Choose the desired ground speed best suited for conditions.
3. Use the table that follows to determine the reel-speed setting for your 5-, 8-, 11-, or 14-blade cutting units. (Figure 51)

Cutting Unit Height	5-blade		8-blade		11-blade		14-blade
	3.8 MPH 6.1 Km/h	5.0 MPH 8.0 Km/h	3.8 MPH 6.1 Km/h	5.0 MPH 8.0 Km/h	3.8 MPH 6.1 Km/h	5.0 MPH 8.0 Km/h	3.8 MPH 6.1 Km/h
0.062" / 1.6mm	N/R	N/R	9	N/R	9	N/R	9
0.094" / 2.4mm	N/R	N/R	9	N/R	9	N/R	9
0.125" / 3.2mm	N/R	N/R	9	N/R	9	N/R	9
0.156" / 4.0mm	N/R	N/R	9	N/R	9	N/R	N/R
0.188" / 4.8mm	N/R	N/R	9	N/R	7	N/R	N/R
0.218" / 5.5mm	N/R	N/R	9	N/R	6	N/R	N/R
0.250" / 6.4mm	7	N/R	6	7	5	7	N/R
0.312" / 7.9mm	6	N/R	5	6	4	6	N/R
0.375" / 9.5mm	6	7	4	5	4	5	N/R
0.438" / 11.1mm	6	6	4	5	3	4	N/R
0.500" / 12.7mm	5	6	3	4	N/R	N/R	N/R
0.625" / 15.9mm	4	5	3	3	N/R	N/R	N/R
0.750" / 19.0mm	3	4	3	3	N/R	N/R	N/R
0.875" / 22.2mm	3	4	N/R	3	N/R	N/R	N/R
1.000" / 25.4mm	3	3	N/R	N/R	N/R	N/R	N/R

g014736
g014736

Figure 51

4. Adjust the reel speed by rotating the knob (Figure 53) until the indicator arrows are in line with the number you determined in step 3.

Note: You can increase or decrease the reel speed to compensate for turf conditions.

Backlapping the Reels

⚠ WARNING

Contact with the reels or other moving parts can result in personal injury.

- Keep your fingers, hands, and clothing away from the reels or other moving parts.
- Never attempt to turn the reels by hand or foot while the engine is running.

1. Park the machine on a level surface, lower the cutting units, shut off the engine, remove the key, and engage the parking brake.
2. Remove the plastic cover to the left side of the seat.
3. Make initial reel to bedknife adjustments appropriate for backlapping on all cutting units which are to be backlapped; refer to the Cutting Unit *Operator's Manual*.

⚠ DANGER

Changing the engine speed while backlapping may cause the reels to stall.

- Never change the engine speed while backlapping.
- Backlap only at idle engine speed.

4. Start the engine and run at low idle speed.
5. Rotate the backlap lever to the REVERSE (R) position (Figure 52).

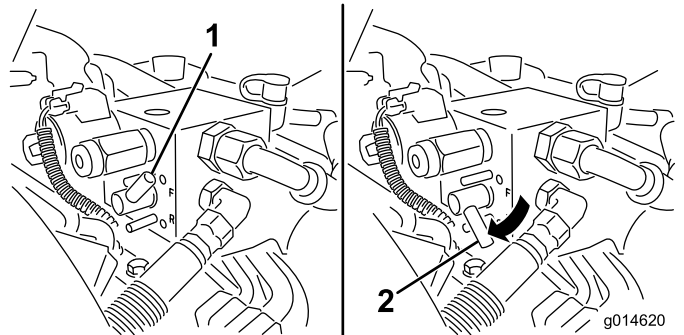

Figure 52

1. Backlap lever—FORWARD
2. Backlap lever—REVERSE position

6. Rotate the reel-speed control to setting 1 (Figure 53).

Diagnostics System

Diagnosing the Service Indicator Light

The service indicator light illuminates in the event of a fault in the machine. When this light is on, you can access the computer codes to diagnose the problem by entering diagnostic mode. In diagnostic mode, the service indicator light flashes a number of times, giving you the error code that you or your authorized Toro distributor can use to identify the problem.

Note: You cannot start the engine in diagnostic mode.

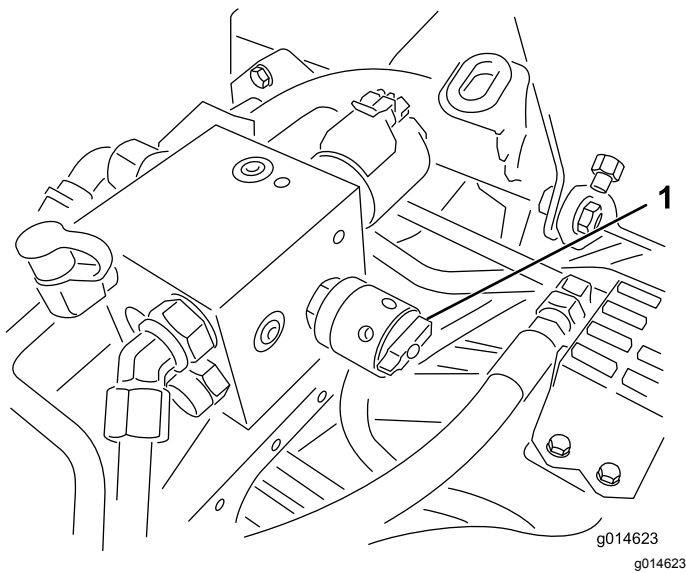

Figure 53

1. Reel-speed control

7. With the functional-control lever in the NEUTRAL position, move the raise/lower mow control forward to start the backlapping operation on the designated reels.
8. Apply lapping compound with a long-handled brush. Never use a short-handled brush.
9. If the reels stall or become erratic while backlapping, select a higher reel speed setting until the speed stabilizes, then return the reel speed to setting 1 or to your desired speed.
10. To make an adjustment to the cutting units while backlapping, turn the reels off by moving the raise/lower mow control rearward and shut off the engine. After completing adjustments, repeat steps 4 through 8.
11. Repeat the procedure for all cutting units you want to backlap.
12. When finished, return the backlap levers to the FORWARD (F) position, replace the cover, and wash all lapping compound off of the cutting units. Adjust cutting unit reel to bedknife as needed. Move the cutting unit reel speed control to the desired mowing position.

Important: If the backlap lever is not returned to the FORWARD (F) position after backlapping, the cutting units will not raise or function properly.

Entering Diagnostic Mode

1. Stop the machine, engage the parking brake, and turn the ignition key to the OFF position.
2. Move the functional-control lever to the TRANSPORT position.
3. Ensure that the backlap lever is set to the FORWARD (F) position.
4. Get off the seat.
5. Hold the raise/lower mow control in the RAISED position.
6. Turn the ignition switch to the RUN position.
7. Count the codes as they begin to flash (you may release the raise/lower mow control once they begin flashing).

When finished, turn the key to the OFF position to exit diagnostic mode.

Determining the Error Code

The system will display the last 3 faults that occurred in the last 40 hours. It displays the faults through a series of blinking lights, as follows:

- If there are no faults, the light will blink steadily at a medium rate without pauses (1 Hz).
- If there is a fault, it will first blink the tens place, followed by a pause, followed by the ones place. For the following examples, a # represents a blink. Examples:
 - If the code is 15, the blink pattern will be #_#####
 - If the code is 42, the blink pattern will be #####_##
 - If the code is 123, the blink pattern will be #####_###
- If there are more than 1 fault, the tens place of the next fault will begin after a pause after the ones place of the first fault.

Note: The system stores only the 3 most recent fault codes.

For a list of error codes, refer to your authorized Toro distributor or the *Service Manual*.

Storage

If you wish to store the machine for a long period of time, the perform following steps:

1. Always shut off the engine, remove the key (if equipped), wait for all moving parts to stop, and allow the machine to cool before adjusting, cleaning, storing, or repairing the machine.
2. Remove accumulations of dirt and old grass clippings. Sharpen the reels and bedknives, if necessary; refer to the cutting unit *Operator's Manual*. Coat the bedknives and reel blades with a rust preventive. Oil all lubrication points.
3. Raise and support the machine to remove its weight from the tires.
4. Replace the hydraulic fluid and filter and inspect the hydraulic lines and fittings. Replace, if necessary; refer to [Changing the Hydraulic Fluid and Filter \(page 38\)](#) and [Checking the Hydraulic Lines and Hoses \(page 38\)](#).
5. All fuel should be removed from the fuel tank. Run the engine until it shuts off. Replace the fuel filter; refer to [Replacing the Fuel Filter \(page 31\)](#).
6. While the engine is still warm, drain the oil from the crankcase. Refill it with fresh oil; refer to [Changing the Engine Oil and Filter \(page 30\)](#).
7. Remove the spark plugs, pour 30 ml (1 fl oz) of SAE 30 oil into the cylinders, and crank slowly to distribute the oil. Replace the spark plugs; refer to [Replacing the Spark Plugs \(page 31\)](#).
8. Clean dirt and chaff from the cylinder, cylinder head fins, and blower housing.
9. Remove the battery and charge it fully; refer to [Servicing the Battery \(page 32\)](#). Either store it on the shelf or on the machine. Leave the cables disconnected if it is stored on the machine. Store the battery in a cool atmosphere to avoid quick deterioration of the charge in the battery.
10. If possible, store the machine in a warm, dry location.

EEA/UK Privacy Notice

Toro's Use of Your Personal Information

The Toro Company ("Toro") respects your privacy. When you purchase our products, we may collect certain personal information about you, either directly from you or through your local Toro company or dealer. Toro uses this information to fulfil contractual obligations - such as to register your warranty, process your warranty claim or to contact you in the event of a product recall - and for legitimate business purposes - such as to gauge customer satisfaction, improve our products or provide you with product information which may be of interest. Toro may share your information with our subsidiaries, affiliates, dealers or other business partners in connection these activities. We may also disclose personal information when required by law or in connection with the sale, purchase or merger of a business. We will never sell your personal information to any other company for marketing purposes.

Retention of your Personal Information

Toro will keep your personal information as long as it is relevant for the above purposes and in accordance with legal requirements. For more information about applicable retention periods please contact legal@toro.com.

Toro's Commitment to Security

Your personal information may be processed in the US or another country which may have less strict data protection laws than your country of residence. Whenever we transfer your information outside of your country of residence, we will take legally required steps to ensure that appropriate safeguards are in place to protect your information and to make sure it is treated securely.

Access and Correction

You may have the right to correct or review your personal data, or object to or restrict the processing of your data. To do so, please contact us by email at legal@toro.com. If you have concerns about the way in which Toro has handled your information, we encourage you to raise this directly with us. Please note that European residents have the right to complain to your Data Protection Authority.

California Proposition 65 Warning Information

What is this warning?

You may see a product for sale that has a warning label like the following:



WARNING: Cancer and Reproductive Harm—www.p65Warnings.ca.gov.

What is Prop 65?

Prop 65 applies to any company operating in California, selling products in California, or manufacturing products that may be sold in or brought into California. It mandates that the Governor of California maintain and publish a list of chemicals known to cause cancer, birth defects, and/or other reproductive harm. The list, which is updated annually, includes hundreds of chemicals found in many everyday items. The purpose of Prop 65 is to inform the public about exposure to these chemicals.

Prop 65 does not ban the sale of products containing these chemicals but instead requires warnings on any product, product packaging, or literature with the product. Moreover, a Prop 65 warning does not mean that a product is in violation of any product safety standards or requirements. In fact, the California government has clarified that a Prop 65 warning "is not the same as a regulatory decision that a product is 'safe' or 'unsafe.'" Many of these chemicals have been used in everyday products for years without documented harm. For more information, go to <https://oag.ca.gov/prop65/faqs-view-all>.

A Prop 65 warning means that a company has either (1) evaluated the exposure and has concluded that it exceeds the "no significant risk level"; or (2) has chosen to provide a warning based on its understanding about the presence of a listed chemical without attempting to evaluate the exposure.

Does this law apply everywhere?

Prop 65 warnings are required under California law only. These warnings are seen throughout California in a wide range of settings, including but not limited to restaurants, grocery stores, hotels, schools, and hospitals, and on a wide variety of products. Additionally, some online and mail order retailers provide Prop 65 warnings on their websites or in catalogs.

How do the California warnings compare to federal limits?

Prop 65 standards are often more stringent than federal and international standards. There are various substances that require a Prop 65 warning at levels that are far lower than federal action limits. For example, the Prop 65 standard for warnings for lead is 0.5 µg/day, which is well below the federal and international standards.

Why don't all similar products carry the warning?

- Products sold in California require Prop 65 labelling while similar products sold elsewhere do not.
- A company involved in a Prop 65 lawsuit reaching a settlement may be required to use Prop 65 warnings for its products, but other companies making similar products may have no such requirement.
- The enforcement of Prop 65 is inconsistent.
- Companies may elect not to provide warnings because they conclude that they are not required to do so under Prop 65; a lack of warnings for a product does not mean that the product is free of listed chemicals at similar levels.

Why does Toro include this warning?

Toro has chosen to provide consumers with as much information as possible so that they can make informed decisions about the products they buy and use. Toro provides warnings in certain cases based on its knowledge of the presence of one or more listed chemicals without evaluating the level of exposure, as not all the listed chemicals provide exposure limit requirements. While the exposure from Toro products may be negligible or well within the "no significant risk" range, out of an abundance of caution, Toro has elected to provide the Prop 65 warnings. Moreover, if Toro does not provide these warnings, it could be sued by the State of California or by private parties seeking to enforce Prop 65 and subject to substantial penalties.



The Toro Warranty

A Two-Year Limited Warranty

Conditions and Products Covered

The Toro Company and its affiliate, Toro Warranty Company, pursuant to an agreement between them, jointly warrant your Toro Commercial product ("Product") to be free from defects in materials or workmanship for two years or 1500 operational hours*, whichever occurs first. This warranty is applicable to all products with the exception of Aerators (refer to separate warranty statements for these products). Where a warrantable condition exists, we will repair the Product at no cost to you including diagnostics, labor, parts, and transportation. This warranty begins on the date the Product is delivered to the original retail purchaser.

* Product equipped with an hour meter.

Instructions for Obtaining Warranty Service

You are responsible for notifying the Commercial Products Distributor or Authorized Commercial Products Dealer from whom you purchased the Product as soon as you believe a warrantable condition exists. If you need help locating a Commercial Products Distributor or Authorized Dealer, or if you have questions regarding your warranty rights or responsibilities, you may contact us at:

Toro Commercial Products Service Department
Toro Warranty Company
8111 Lyndale Avenue South
Bloomington, MN 55420-1196
952-888-8801 or 800-952-2740
E-mail: commercial.warranty@toro.com

Owner Responsibilities

As the Product owner, you are responsible for required maintenance and adjustments stated in your *Operator's Manual*. Failure to perform required maintenance and adjustments can be grounds for disallowing a warranty claim.

Items and Conditions Not Covered

Not all product failures or malfunctions that occur during the warranty period are defects in materials or workmanship. This warranty does not cover the following:

- Product failures which result from the use of non-Toro replacement parts, or from installation and use of add-on, or modified non-Toro branded accessories and products. A separate warranty may be provided by the manufacturer of these items.
- Product failures which result from failure to perform recommended maintenance and/or adjustments. Failure to properly maintain your Toro product per the Recommended Maintenance listed in the *Operator's Manual* can result in claims for warranty being denied.
- Product failures which result from operating the Product in an abusive, negligent, or reckless manner.
- Parts subject to consumption through use unless found to be defective. Examples of parts which are consumed, or used up, during normal Product operation include, but are not limited to, brake pads and linings, clutch linings, blades, reels, rollers and bearings (sealed or greasable), bed knives, spark plugs, castor wheels and bearings, tires, filters, belts, and certain sprayer components such as diaphragms, nozzles, and check valves, etc.
- Failures caused by outside influence. Conditions considered to be outside influence include, but are not limited to, weather, storage practices, contamination, use of unapproved fuels, coolants, lubricants, additives, fertilizers, water, or chemicals, etc.
- Failure or performance issues due to the use of fuels (e.g. gasoline, diesel, or biodiesel) that do not conform to their respective industry standards.

Countries Other than the United States or Canada

Customers who have purchased Toro products exported from the United States or Canada should contact their Toro Distributor (Dealer) to obtain guarantee policies for your country, province, or state. If for any reason you are dissatisfied with your Distributor's service or have difficulty obtaining guarantee information, contact the Toro importer.

- Normal noise, vibration, wear and tear, and deterioration.
- Normal "wear and tear" includes, but is not limited to, damage to seats due to wear or abrasion, worn painted surfaces, scratched decals or windows, etc.

Parts

Parts scheduled for replacement as required maintenance are warranted for the period of time up to the scheduled replacement time for that part. Parts replaced under this warranty are covered for the duration of the original product warranty and become the property of Toro. Toro will make the final decision whether to repair any existing part or assembly or replace it. Toro may use remanufactured parts for warranty repairs.

Deep Cycle and Lithium-Ion Battery Warranty:

Deep cycle and Lithium-Ion batteries have a specified total number of kilowatt-hours they can deliver during their lifetime. Operating, recharging, and maintenance techniques can extend or reduce total battery life. As the batteries in this product are consumed, the amount of useful work between charging intervals will slowly decrease until the battery is completely worn out. Replacement of worn out batteries, due to normal consumption, is the responsibility of the product owner. Battery replacement may be required during the normal product warranty period at owner's expense. Note: (Lithium-Ion battery only): A Lithium-Ion battery has a part only prorated warranty beginning year 3 through year 5 based on the time in service and kilowatt hours used. Refer to the *Operator's Manual* for additional information.

Maintenance is at Owner's Expense

Engine tune-up, lubrication, cleaning and polishing, replacement of filters, coolant, and completing recommended maintenance are some of the normal services Toro products require that are at the owner's expense.

General Conditions

Repair by an Authorized Toro Distributor or Dealer is your sole remedy under this warranty.

Neither The Toro Company nor Toro Warranty Company is liable for indirect, incidental or consequential damages in connection with the use of the Toro Products covered by this warranty, including any cost or expense of providing substitute equipment or service during reasonable periods of malfunction or non-use pending completion of repairs under this warranty. Except for the Emissions warranty referenced below, if applicable, there is no other express warranty. All implied warranties of merchantability and fitness for use are limited to the duration of this express warranty.

Some states do not allow exclusions of incidental or consequential damages, or limitations on how long an implied warranty lasts, so the above exclusions and limitations may not apply to you. This warranty gives you specific legal rights, and you may also have other rights which vary from state to state.

Note regarding engine warranty:

The Emissions Control System on your Product may be covered by a separate warranty meeting requirements established by the U.S. Environmental Protection Agency (EPA) and/or the California Air Resources Board (CARB). The hour limitations set forth above do not apply to the Emissions Control System Warranty. Refer to the Engine Emission Control Warranty Statement supplied with your product or contained in the engine manufacturer's documentation for details.