



Count on it.

Parts Catalog

3 Bushel Soft Bag

**36 Inch and Larger Fixed and Floating Deck
Walk-Behind Mower**

Model No. 30104



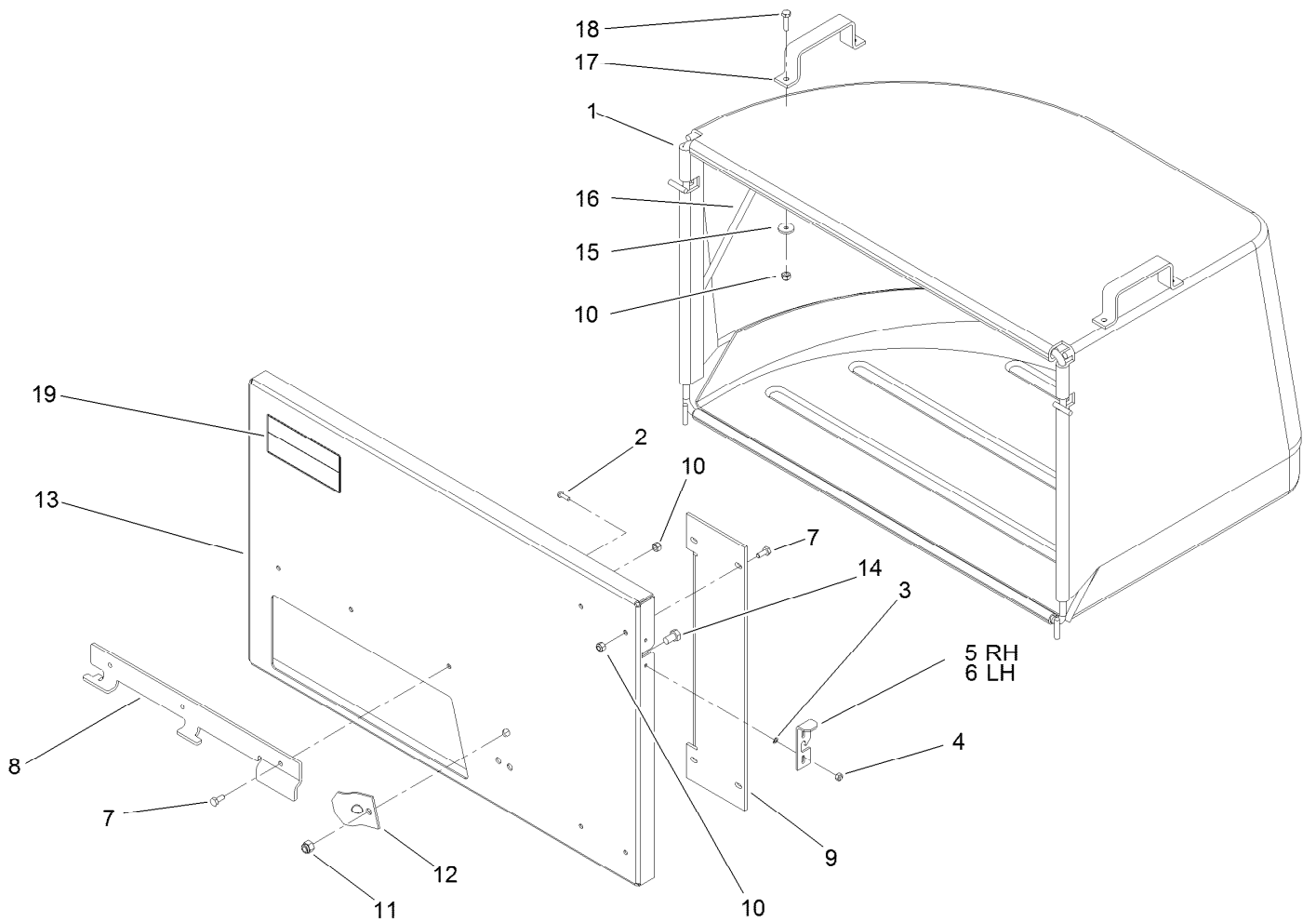

Bagger Assembly

<i>Ref.</i>	<i>Part Number</i>	<i>Qty.</i>	<i>Description</i>	<i>Ref.</i>	<i>Part Number</i>	<i>Qty.</i>	<i>Description</i>
1	131-1465	1	Pan And Catcher	11	3296-39	1	Nut-Lock, NI
2	3290-500	4	Screw-PPH	12	104-8575	1	Bracket-Clamp
3	1-805500	4	Washer-Spring	13	104-8577-03	1	Plate-Bagger
4	3296-2	4	Nut-Lock, NI	14	323-34	1	Screw-HH
5	1-353012	1	Latch-Catcher, RH	15	1-353029	4	Washer
6	1-353011	1	Latch-Catcher, LH	16	1-352007-03	1	Frame-Catcher
7	321-3	7	Screw-HH	17	1-353005-03	2	Handle
8	104-8573-03	1	Bracket-Mounting	18	321-6	4	Screw-HH
9	106-5542-03	1	Bracket-Support, Bagger	19	114-3489	1	Decal-Warning, Bagger
10	3296-42	11	Nut-Lock, NI				