



**Count on it.**

**Operator's Manual**

**Groundsmaster® 360 4-Wheel  
Drive Multi-Purpose Machine**

Model No. 31223—Serial No. 403330001 and Up

Model No. 31230—Serial No. 403330001 and Up

Model No. 31236—Serial No. 403330001 and Up



This product complies with all relevant European directives; for details, please see the separate product specific Declaration of Conformity (DOC) sheet.

Genuine Toro spark arresters are approved by the USDA Forestry Service.

It is a violation of California Public Resource Code Section 4442 or 4443 to use or operate the engine on any forest-covered, brush-covered, or grass-covered land unless the engine is equipped with a spark arrester, as defined in Section 4442, maintained in effective working order or the engine is constructed, equipped, and maintained for the prevention of fire.

The enclosed engine owner's manual is supplied for information regarding the US Environmental Protection Agency (EPA) and the California Emission Control Regulation of emission systems, maintenance, and warranty. Replacements may be ordered through the engine manufacturer.

## ⚠ WARNING

### CALIFORNIA Proposition 65 Warning

Diesel engine exhaust and some of its constituents are known to the State of California to cause cancer, birth defects, and other reproductive harm.

Battery posts, terminals, and related accessories contain lead and lead compounds, chemicals known to the State of California to cause cancer and reproductive harm. Wash hands after handling.

Use of this product may cause exposure to chemicals known to the State of California to cause cancer, birth defects, or other reproductive harm.

# Introduction

This machine is a ride-on, multi-purpose machine intended to be used by professional, hired operators in commercial applications. It is primarily designed for maintaining grass on well-maintained lawns in parks, sports fields, and on commercial grounds. It is not designed for cutting brush.

**Important:** To maximize the safety, performance, and proper operation of this machine, carefully read and fully understand the contents of this *Operator's Manual*. Failing to follow these

**operating instructions or to receive proper training may result in injury. For more information on safe operating practices, including safety tips and training materials, go to [www.Toro.com](http://www.Toro.com).**

You may contact Toro directly at [www.Toro.com](http://www.Toro.com) for product safety and operation training materials, accessory information, help finding a dealer, or to register your product.

Whenever you need service, genuine Toro parts, or additional information, contact an authorized Toro distributor or Toro Customer Service and have the model and serial numbers of your product ready. **Figure 1** identifies the location of the model and serial numbers on the product. Write the numbers in the space provided.

**Important:** With your mobile device, you can scan the QR code on the serial number decal (if equipped) to access warranty, parts, and other product information.

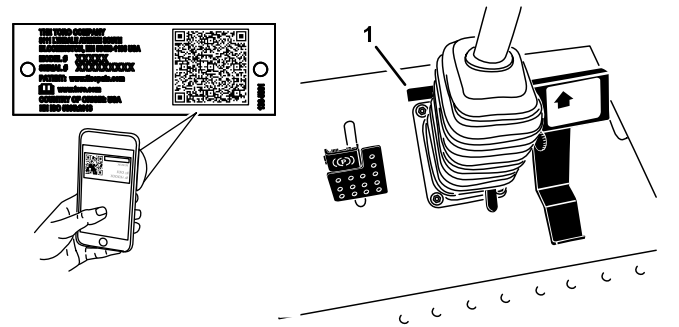

Figure 1

1. Model and serial number location

Model No.	_____
Serial No.	_____

This manual identifies potential hazards and has safety messages identified by the safety-alert symbol (**Figure 2**), which signals a hazard that may cause serious injury or death if you do not follow the recommended precautions.



Figure 2

Safety-alert symbol

This manual also uses 2 words to highlight information. **Important** calls attention to special mechanical information and **Note** emphasizes general information worthy of special attention.

# Contents

Safety .....	4	Changing the Engine Oil and Filter .....	38
General Safety .....	4	Adjusting the Throttle .....	39
Safety and Instructional Decals .....	4	Fuel System Maintenance .....	39
Setup .....	12	Servicing the Water Separator .....	39
1 Installing the PTO Driveshaft to an Optional Mower Deck or QAS .....	12	Bleeding the Fuel System .....	40
2 Using the Optional Mower-Deck-Mounting Hardware .....	13	Bleeding Air from the Fuel Injectors .....	40
3 Adjusting the Roll Bar .....	13	Cleaning the Fuel Tank .....	41
4 Checking the Tire Pressure .....	14	Checking the Fuel Lines and Connections .....	41
5 Checking the Fluid Levels .....	14	Electrical System Maintenance .....	41
Product Overview .....	14	Electrical System Safety .....	41
Controls .....	14	Servicing the Battery .....	41
Cab Controls .....	17	Checking the Fuses .....	42
Specifications .....	18	Storing the Battery .....	42
Attachments/Accessories .....	19	Diagnostic Ace Display .....	42
Before Operation .....	19	Checking the Interlock Switches .....	42
Before Operation Safety .....	19	Drive System Maintenance .....	45
Adding Fuel .....	20	Checking the Tire Pressure .....	45
Checking the Engine-Oil Level .....	21	Correcting the Steering Misalignment .....	45
Checking the Cooling System .....	21	Cooling System Maintenance .....	46
Checking the Hydraulic System .....	21	Cooling System Safety .....	46
The Safety-Interlock System .....	21	Checking the Cooling System .....	46
Positioning the Standard Seat .....	21	Cleaning the Radiator .....	46
Raising and Lowering the Seat .....	22	Brake Maintenance .....	47
During Operation .....	23	Adjusting the Brakes .....	47
During Operation Safety .....	23	Adjusting the Parking Brake .....	47
Starting the Engine .....	25	Belt Maintenance .....	48
Shutting Off the Engine .....	26	Checking the Alternator Belt .....	48
Driving the Machine .....	26	Controls System Maintenance .....	49
Stopping the Machine .....	26	Adjusting the Traction Drive for Neutral .....	49
Selecting the Steering Mode .....	26	Adjusting the Maximum Ground Speed .....	49
Operating the Mower Deck or Attachment .....	27	Hydraulic System Maintenance .....	50
Adjusting the Height of Cut .....	27	Hydraulic System Safety .....	50
Operating Tips .....	28	Hydraulic Fluid Specification .....	50
After Operation .....	29	Checking the Hydraulic System .....	50
After Operation Safety .....	29	Changing the Hydraulic Fluid And Filter .....	51
Pushing the Machine by Hand .....	29	Cab Maintenance .....	52
Hauling the Machine .....	29	Cleaning the Cab .....	52
Locating the Tie-Down Points .....	30	Filling the Washer-Fluid Bottle .....	52
Maintenance .....	31	Cleaning the Cab Air Filters .....	52
Maintenance Safety .....	31	Cleaning the Air-Conditioning Coil .....	53
Recommended Maintenance Schedule(s) .....	31	Cleaning .....	54
Daily Maintenance Checklist .....	33	Waste Disposal .....	54
Pre-Maintenance Procedures .....	34	Storage .....	55
Preparing the Machine for Maintenance .....	34	Preparing the Engine .....	55
Using the Hood-Prop Rod .....	34	Preparing the Machine .....	55
Lubrication .....	35		
Greasing the Bearings and Bushings .....	35		
Engine Maintenance .....	37		
Engine Safety .....	37		
Servicing the Air Cleaner .....	37		
Servicing the Engine Oil .....	37		
Checking the Engine-Oil Level .....	37		
Crankcase Oil Capacity .....	38		

# Safety

This machine has been designed in accordance with EN ISO 5395:2013 and ANSI B71.4-2017.

## General Safety

This product is capable of amputating hands and feet and of throwing objects. Always follow all safety instructions to avoid serious personal injury.

Using this product for purposes other than its intended use could prove dangerous to you and bystanders.

- Read and understand the contents of this *Operator's Manual* before starting the engine.
- Use your full attention while operating the machine. Do not engage in any activity that causes distractions; otherwise, injury or property damage may occur.
- Do not put your hands or feet near moving components of the machine.

- Do not operate the machine without all guards and other safety protective devices in place and working on the machine.
- Keep clear of any discharge opening. Keep bystanders and pets a safe distance away from the machine.
- Keep children out of the operating area. Never allow children to operate the machine.
- Stop the machine, shut off the engine, remove the key, and wait for all moving parts to stop before servicing, fueling, or unclogging the machine.

Improperly using or maintaining this machine can result in injury. To reduce the potential for injury, comply with these safety instructions and always pay attention to the safety-alert symbol **▲**, which means Caution, Warning, or Danger—personal safety instruction. Failure to comply with these instructions may result in personal injury or death.

You can find additional safety information where needed throughout this *Operator's Manual*.

## Safety and Instructional Decals



Safety decals and instructions are easily visible to the operator and are located near any area of potential danger. Replace any decal that is damaged or missing.

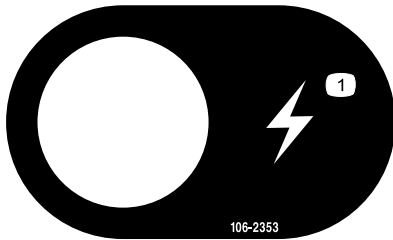

106-2353

decal106-2353

1. Electrical power point

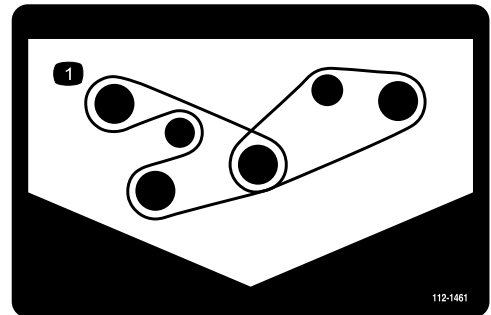

112-1461

decal112-1461

1. Belt routing

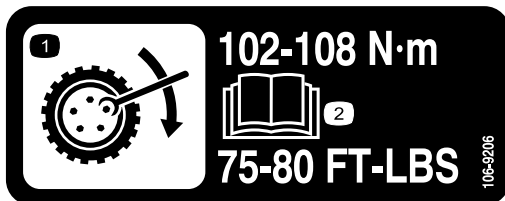

106-9206

decal106-9206

1. Wheel-torque specifications
2. Read the *Operator's Manual*.

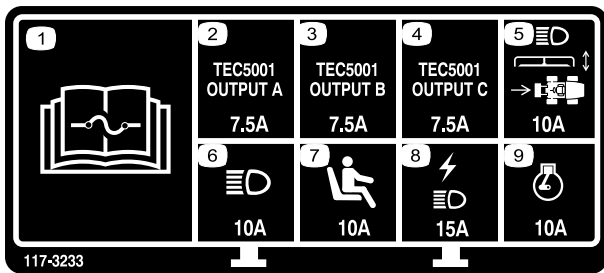

117-3233

decal117-3233

1. Read the *Operator's Manual* for information on fuses.
2. 4-wheel steer solenoid—7.5 A
3. PTO enable, 4-wheel-steer lamp, deck lift, deck float—7.5 A
4. Glow indicator, fuel-run solenoid, diagnostic light, start—7.5 A
5. Headlights, deck actuator, power takeoff—10 A
6. Lights—15 A
7. Operator-presence switch—10 A
8. Power point, lights—15 A
9. Engine—10 A



117-3272

decal117-3272

1. Warning—read the *Operator's Manual*; failure to use the rollover protection system (ROPS) can result in injury in the event of a rollover; wear a seat belt when a roll bar is in place, do not wear a seat belt when the roll bar is lowered.

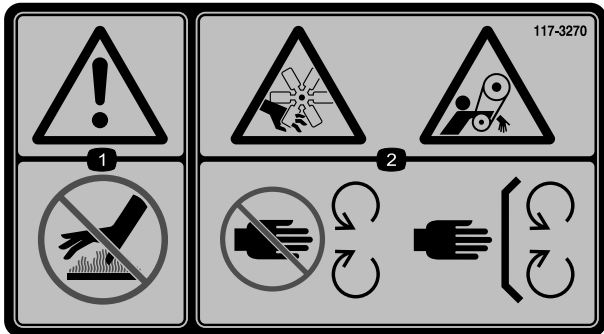

117-3270

decal117-3270

1. Warning—do not touch the hot surface.
2. Cutting/dismemberment hazard, hand; entanglement hazard, belt—stay away from moving parts, keep all guards and shields in place.



117-3276

decal117-3276

1. Engine coolant under pressure
2. Explosion hazard—read the *Operator's Manual*.
3. Warning—do not touch the hot surface.
4. Warning—read the *Operator's Manual*.

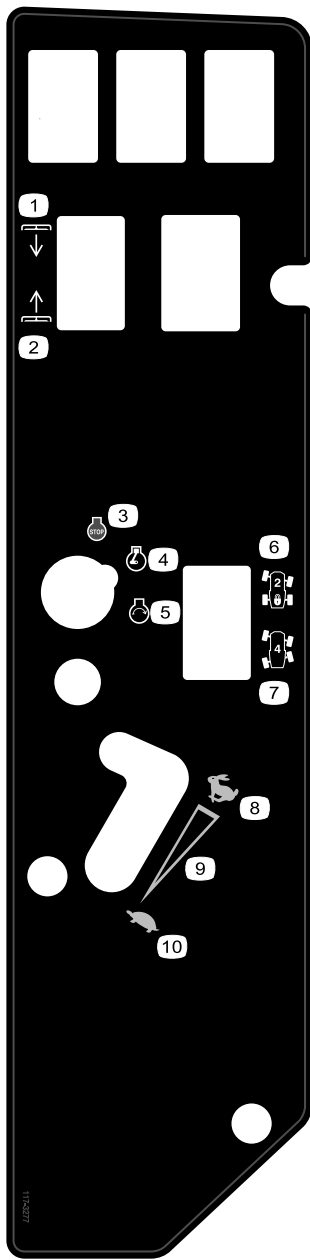

**117-3277**

decal117-3277

- |                 |                                |
|-----------------|--------------------------------|
| 1. Lower decks  | 6. Two-wheel steering          |
| 2. Raise decks  | 7. Four-wheel steering         |
| 3. Engine—stop  | 8. Fast                        |
| 4. Engine—run   | 9. Continuous variable setting |
| 5. Engine—start | 10. Slow                       |

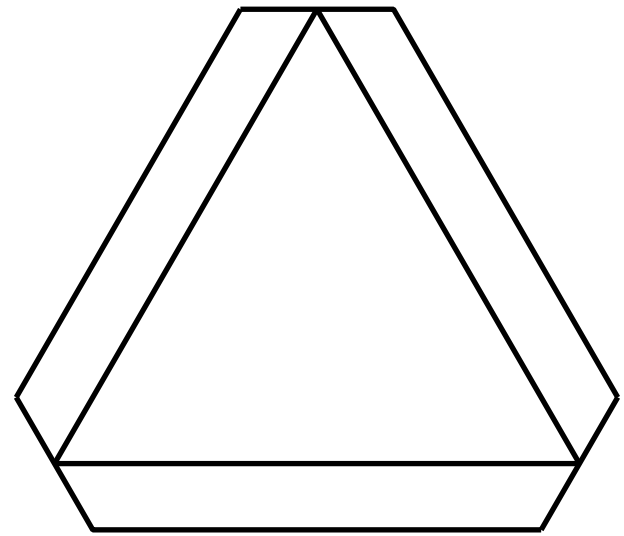

**120-0250**

decal120-0250

1. Slow-moving vehicle

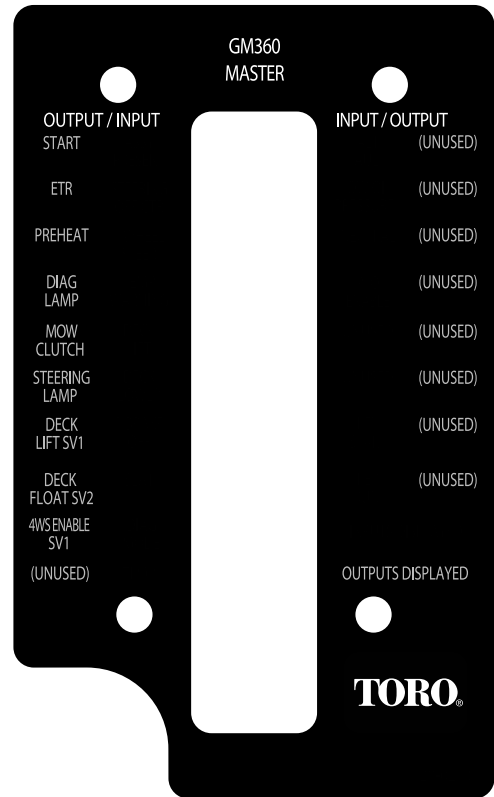

**120-0273**

decal120-0273



**117-4766**

decal117-4766

1. Cutting/dismemberment hazard, fan—stay away from moving parts; keep all guards and shields in place.

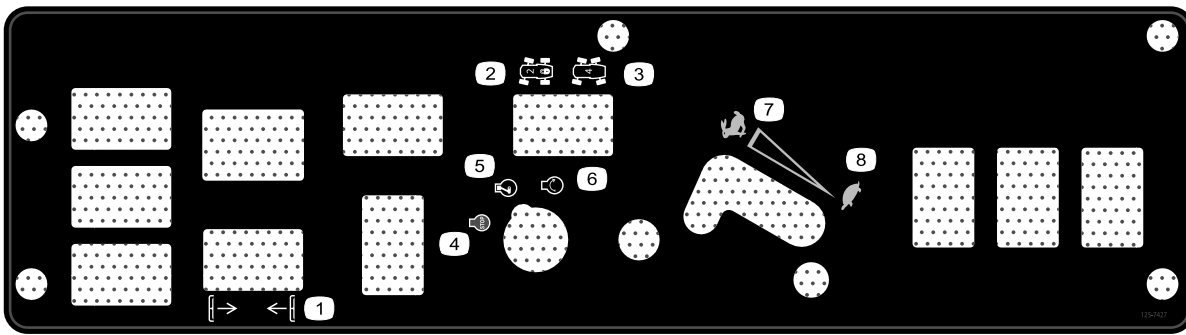

decal125-7427

**125-7427**

- |                      |                 |
|----------------------|-----------------|
| 1. Raise/Lower decks | 5. Engine—run   |
| 2. 2-wheel steering  | 6. Engine—start |
| 3. 4-wheel steering  | 7. Fast         |
| 4. Engine—stop       | 8. Slow         |

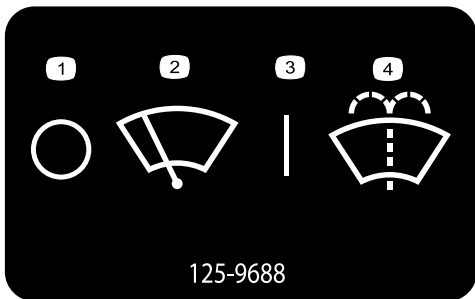

decal125-9688

**125-9688**

Model with Cab Only

- |                          |                                  |
|--------------------------|----------------------------------|
| 1. Windshield wipers—off | 3. Windshield wipers—on          |
| 2. Windshield wipers     | 4. Spray windshield washer fluid |

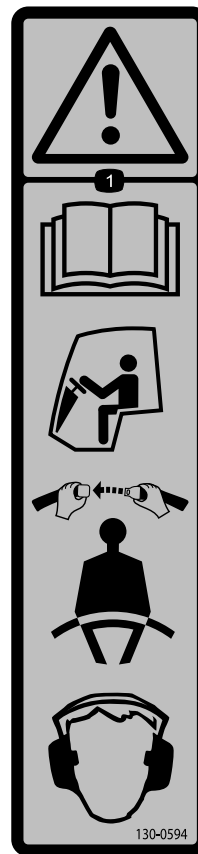

decal130-0594

**130-0594**

Model with Cab Only

1. Warning—read the *Operator's Manual*; when sitting in the cab, always wear a seat belt; wear hearing protection.

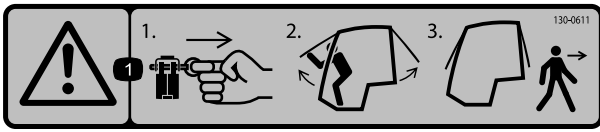

decal130-0611

**130-0611**

Model with Cab Only

1. Warning—1) Remove the pin; 2) Raise the doors; 3) Exit the cab

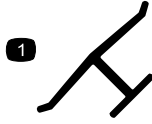

decaloemmark

**Manufacturer's Mark**

1. Indicates that the blade is identified as a part from the original machine manufacturer.

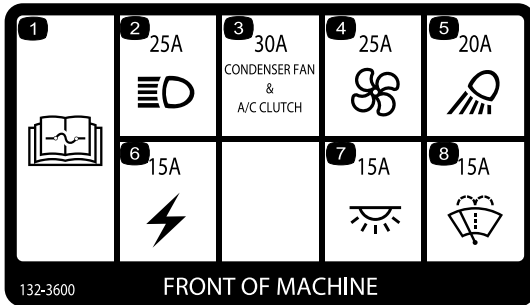

decal132-3600

**132-3600**

Model with Cab Only

- |   |                             |
|---|-----------------------------|
| 1. Read the <i>Operator's Manual</i> for more information on fuses. | 5. Working light (20 A)     |
| 2. Headlight (25 A)   | 6. Auxiliary power (15 A)   |
| 3. Condenser fan and A/C clutch (30 A)                              | 7. Cab light (15 A)         |
| 4. Fan (25 A)   | 8. Windshield wipers (15 A) |

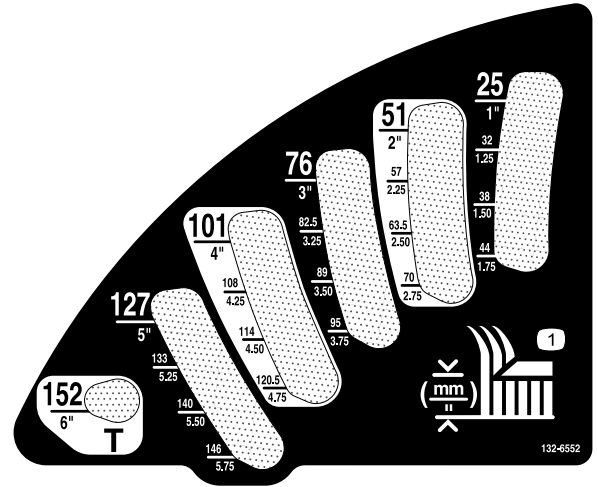

decal132-6552

**132-6552**

2-Wheel Drive with ROPS and 4-Wheel Drive with ROPS Models Only

1. Height of cut

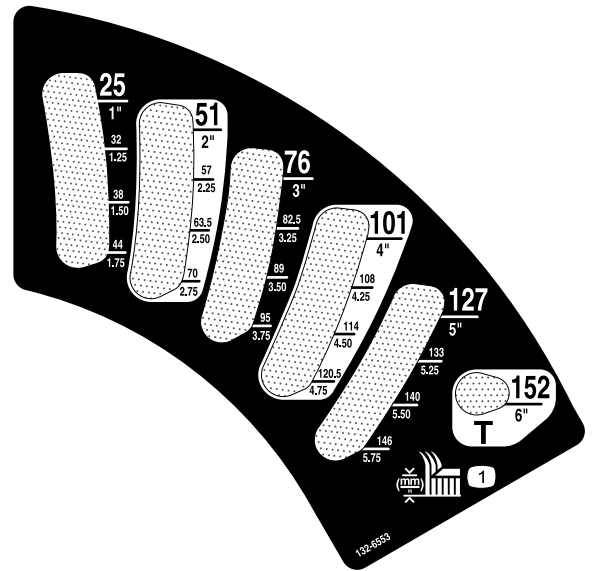

decal132-6553

**132-6553**

Model with Cab Only

1. Height of cut

**⚠ WARNING: Cancer and Reproductive Harm - [www.P65Warnings.ca.gov](http://www.P65Warnings.ca.gov).**  
 For more information, please visit [www.ttcoCAProp65.com](http://www.ttcoCAProp65.com)  
**CALIFORNIA SPARK ARRESTER WARNING**  
 Operation of this equipment may create sparks that can start fires around dry vegetation. A spark arrester may be required. The operator should contact local fire agencies for laws or regulations relating to fire prevention requirements.

133-8062

**133-8062**

decal133-8062





### Battery Symbols

Some or all of these symbols are on your battery.

- |  |   |
|--|---|
| 1. Explosion hazard                    | 6. Keep bystanders a safe distance away from the battery.                       |
| 2. No fire, open flame, or smoking     | 7. Wear eye protection; explosive gases can cause blindness and other injuries. |
| 3. Caustic liquid/chemical burn hazard | 8. Battery acid can cause blindness or severe burns.                            |
| 4. Wear eye protection.                | 9. Flush eyes immediately with water and get medical help fast.                 |
| 5. Read the <i>Operator's Manual</i> . | 10. Contains lead; do not discard.  |

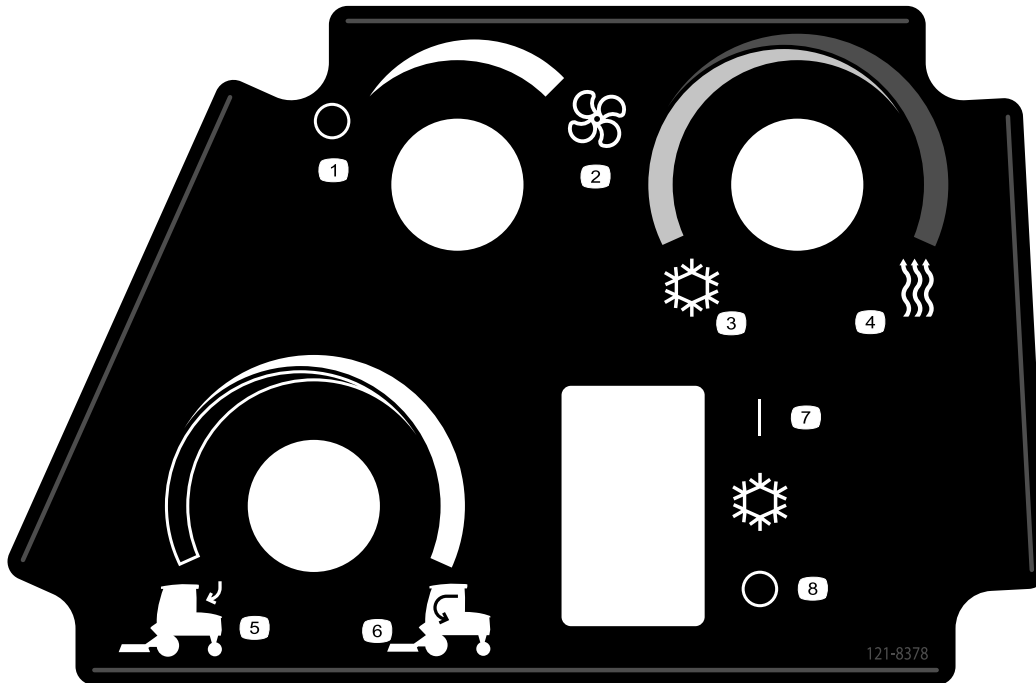

**121-8378**

Model with Cab Only

- |                |                        |
|----------------|------------------------|
| 1. Fan—off     | 5. External air        |
| 2. Fan—on full | 6. Internal air        |
| 3. Cold air    | 7. Air conditioner—off |
| 4. Hot air     | 8. Air conditioner—on  |

decal121-8378

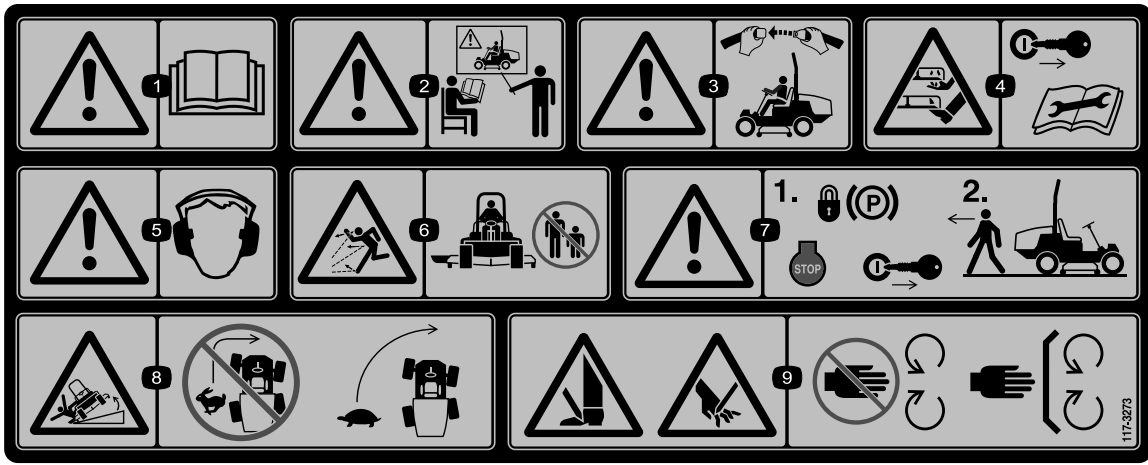

decal117-3273

**117-3273**

1. Warning—read the *Operator's Manual*.
2. Warning—do not operate this machine unless you are trained.
3. Warning—wear the seat belt when seated in the operator's position.
4. Cutting/dismemberment hazard of hand or foot—remove the key from the key switch and read the instructions before servicing or performing maintenance.
5. Warning—wear hearing protection.
6. Thrown object hazard—keep bystanders a safe distance away from the machine.
7. Warning—engage the parking brake, shut off the engine, and remove the key from the key switch before leaving the machine.
8. Tipping hazard—lower the cutting unit when driving down slopes; slow the machine before turning, do not turn at high speeds.
9. Cutting hazard of hand or foot—stay away from moving parts; keep all guards in place.

## GROUNDMASTER 360

**CHECK/SERVICE (daily)**

1. OIL LEVEL, ENGINE
2. OIL LEVEL, HYDRAULIC TANK
3. COOLANT LEVEL, RADIATOR
4. FUEL /WATER SEPARATOR
5. PRECLEANER - AIR CLEANER
6. RADIATOR SCREEN
7. BRAKE FUNCTION
8. TIRE PRESSURE
9. BATTERY
10. BELTS - DECK, FAN, ALTERNATOR
11. GEARBOX

GREASING - SEE OPERATOR'S MANUAL

## QUICK REFERENCE AID

SEE OPERATOR'S MANUAL FOR INITIAL CHANGES.	FLUID TYPE	CAPACITY	CHANGE INTERVAL*		FILTER PART NO.
			FLUID	FILTER	
A. ENGINE OIL	4 CYL.-1.5L	5.5 QTS. (5.2 LITERS)	150 HRS.	150 HRS.	108-3841
	3 CYL.-1.1L	3.9 QTS. (3.7 LITERS)			
B. HYDRAULIC CIRCUIT OIL	MOBIL 424	4.5 GALS. (17 LITERS)	800 HRS.	800 HRS.	108-5194
C. AIR CLEANER				SEE INDICATOR	108-3810
D. WATER SEPARATOR				400 HRS.	110-9049
E. FUEL TANK	NO. 2-Diesel	13.5 GALS. (51.1 LITERS)	Drain and flush, 2 yrs.		
F. COOLANT	50/50 Ethylene glycol/water	8 QTS. (7.5 LITERS)	Drain and flush, 2 yrs.		
G. GEARBOX	SAE EP90W	12 oz. (355 mL)	400 HRS.		

\*SEE OPERATOR'S MANUAL FOR INITIAL CHANGES / WINTER USE.

decal120-0259

**120-0259**

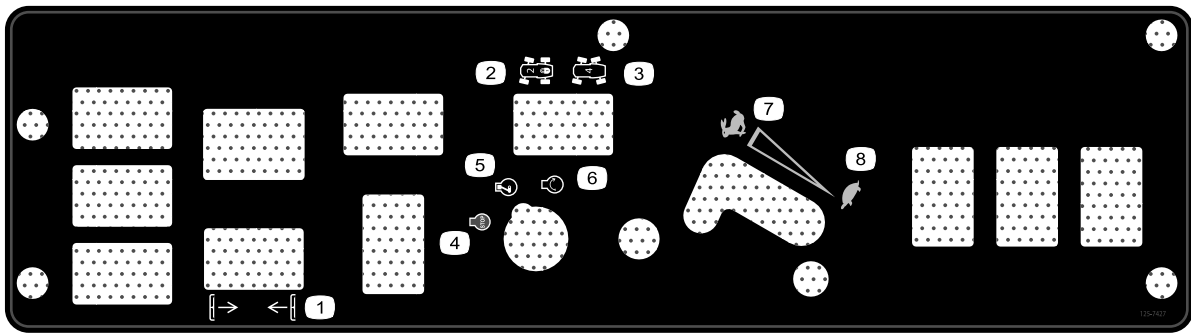

decal132-3378

### 132-3378

Model with Cab Only

- |                      |                 |
|----------------------|-----------------|
| 1. Raise/Lower decks | 5. Engine—run   |
| 2. 2-wheel steering  | 6. Engine—start |
| 3. 4-wheel steering  | 7. Fast         |
| 4. Engine—stop       | 8. Slow         |
-

# Setup

## Loose Parts

Use the chart below to verify that all parts have been shipped.

Procedure	Description	Qty.	Use
<b>1</b>	PTO driveshaft	1	Install the PTO driveshaft to a optional deck or QAS.
	Bolt (5/16 x 1-3/4 inches)	4	
	Locknut (5/16 inch)	4	
	Roll pin (3/16 x 1-1/2 inches)	2	
<b>2</b>	Retainer pin	2	Use the hardware to install the optional mower deck.
	Grease fitting	2	
	Washer head screw (5/16 x 7/8 inch)	2	
<b>3</b>	No parts required	–	Adjust the roll bar.
<b>4</b>	No parts required	–	Check the tire pressure.
<b>5</b>	No parts required	–	Check the hydraulic fluid, engine oil, and coolant levels.

## Media and Additional Parts

Description	Qty.	Use
Operator's Manual	1	Review it before operating the machine.
Engine owner's manual	1	Use it to reference engine information.
Declaration of Conformity	1	
Ignition keys	2	Start the engine.

# 1

## Installing the PTO Driveshaft to an Optional Mower Deck or QAS

Parts needed for this procedure:

1	PTO driveshaft
4	Bolt (5/16 x 1-3/4 inches)
4	Locknut (5/16 inch)
2	Roll pin (3/16 x 1-1/2 inches)

## Procedure

**Note:** Installing the PTO driveshaft is easier if you position the machine on a hoist.

1. Park the machine on a level surface, engage the parking brake, shut off the engine, and remove the key.

### **▲ WARNING**

If you start the engine and allow the PTO to rotate, serious personal injury and machine damage could result.

- Do not start the engine and engage the PTO switch when the PTO driveshaft is disconnected from the cutting deck.
- Before you disconnect the PTO driveshaft from the cutting deck, disconnect the PTO solenoid-valve-coil connector from the wire harness to prevent unintentionally engaging the PTO clutch.

2. Disconnect the wire-harness connector from the PTO solenoid-valve-coil connector ([Figure 3](#)).

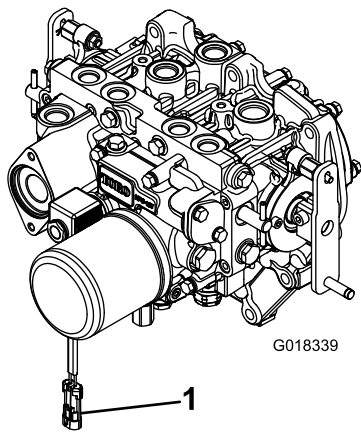

Figure 3

1. Wire-harness connector

3. Position the PTO driveshaft under the front of the machine. Ensure that the slip-shaft yoke of the driveshaft is positioned toward the transmission driveshaft (Figure 4).

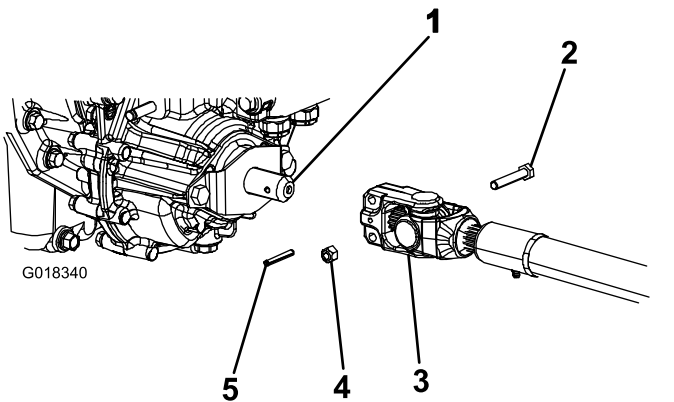

Figure 4

1. Transmission driveshaft
2. Bolt
3. PTO driveshaft
4. Locknut
5. Roll pin

4. Align the spline and roll-pin hole of the driveshaft yoke with the transmission driveshaft.
5. Slide the PTO driveshaft end yoke onto the transmission driveshaft.
6. Secure the end yoke of the PTO driveshaft as follows:
  - A. Install the roll pin in the end yoke and shaft.
  - B. Install the bolts through the driveshaft end yoke.
  - C. Install and tighten the locknuts to secure the end yoke to the PTO driveshaft.

**Note:** Retain the remaining bolts, locknuts, and roll pin to secure the other end of the driveshaft to the attachment gearbox shaft.

D. Torque the locknuts to 20 to 25 N·m (175 to 225 in·lb).

7. Lubricate the grease fittings on the PTO driveshaft.
8. After you connect the other end of the driveshaft to the attachment gearbox shaft, connect the wire-harness connector to the PTO solenoid-valve-coil connector (Figure 3).

## 2

### Using the Optional Mower-Deck-Mounting Hardware

Parts needed for this procedure:

2	Retainer pin
2	Grease fitting
2	Washer head screw (5/16 x 7/8 inch)

### Procedure

**Note:** These components and procedure are required only if a mower deck that requires retainer pins is mounted to the traction unit. Refer to the mower deck *Operator's Manual* for the installation instructions.

**Note:** If you are not installing a mower deck on the traction unit, remove or tie up the 4 deck-lift chains from the lift suspension.

## 3

### Adjusting the Roll Bar

No Parts Required

### Procedure

1. Remove the 2 hairpins and the 2 pins from the roll bar (Figure 5).
2. Raise the roll bar to the upright position and secure it with the 2 pins and 2 hairpins (Figure 5).

**Note:** If you must lower the roll bar, push the bar forward to relieve pressure on the pins, remove the pins, lower the bar slowly, and secure it with the pins so that it does not damage the hood.

# Product Overview

## Controls

Become familiar with all the controls before you start the engine and operate the machine.

### Traction Pedal

The traction pedal ([Figure 6](#)) controls the forward and reverse operation. Press the top of the pedal to move forward and the bottom to move rearward. The ground speed depends on how far you press the pedal. For no load, maximum ground speed, fully press the pedal while the throttle is in the FAST position.

To stop the machine, reduce the foot pressure on the traction pedal and allow it to return to the center position.

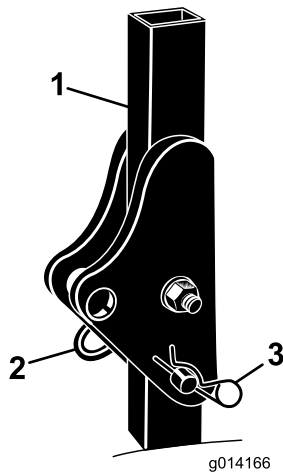

Figure 5

g014166

1. Roll bar
2. Pin
3. Hairpin

## 4

### Checking the Tire Pressure

No Parts Required

#### Procedure

The tires are overinflated for shipping. Therefore, release some of the air to reduce the pressure; refer to [Checking the Tire Pressure](#) (page 45).

## 5

### Checking the Fluid Levels

No Parts Required

#### Procedure

1. Check the hydraulic-fluid level before starting the engine, refer to [Checking the Hydraulic System](#) (page 50).
2. Check the engine-oil level before starting the engine, refer to [Checking the Engine-Oil Level](#) (page 37).
3. Check the cooling system before starting the engine; refer to [Checking the Cooling System](#) (page 46).

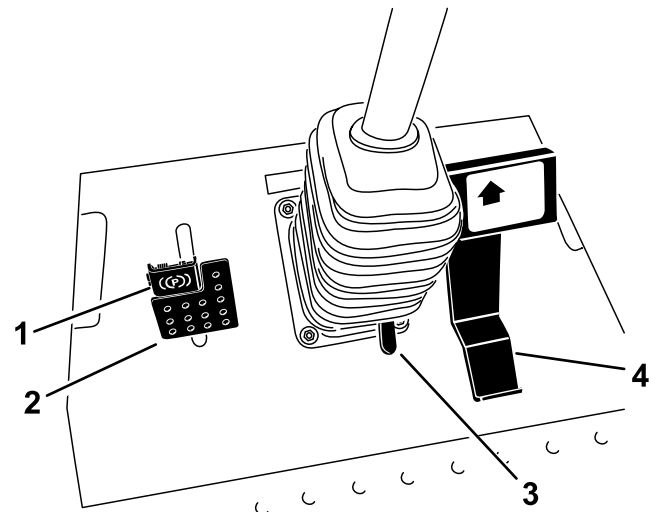

Figure 6

g197397

1. Parking brake
2. Brake pedal
3. Tilt-steering pedal
4. Traction pedal

### Brake Pedal

Use the brake pedal with the brake-pedal latch to engage and disengage the parking brake ([Figure 6](#)). To stop the machine, release the traction pedal and allow it to return to the center position. You can use the brake to assist in stopping the machine in an emergency situation.

### Tilt-Steering Pedal

To tilt the steering wheel toward you, press the foot pedal down, pull the steering tower toward you to the most comfortable position, and release the pedal ([Figure 6](#)). To move the steering wheel away from

you, press the foot pedal and release it when the steering wheel reaches the desired operating position.

## Parking Brake

To engage the parking brake, push down on the brake pedal and press the top forward to latch it (Figure 6). To disengage the parking brake, press the brake pedal until the parking-brake latch retracts.

## Key Switch

The ignition switch has 3 positions: OFF, ON/PREHEAT, and START (Figure 7).

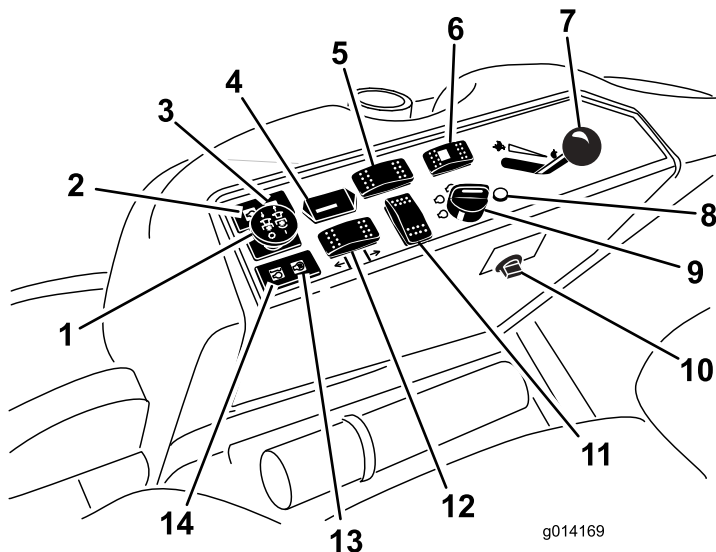

Figure 7

- |  |  |
|--|--|
| 1. Power-takeoff (PTO) switch                    | 8. Diagnostic light (4-wheel-drive only) |
| 2. Oil-pressure-warning light                    | 9. Ignition switch                       |
| 3. Charge-indicator light                        | 10. Power point                          |
| 4. Hour meter                                    | 11. Optional switch location             |
| 5. Differential-lock switch (2-wheel-drive only) | 12. Deck-lift switch                     |
| 6. Steering-selector switch (4-wheel-drive only) | 13. Glow-plug light                      |
| 7. Throttle lever                                | 14. Coolant-temperature-warning light    |

## Power-Takeoff (PTO) Switch

The power-takeoff (PTO) switch starts and stops the attachment (Figure 7).

## Fuel Gauge

The fuel gauge (Figure 8) indicates the amount of fuel remaining in the fuel tank.

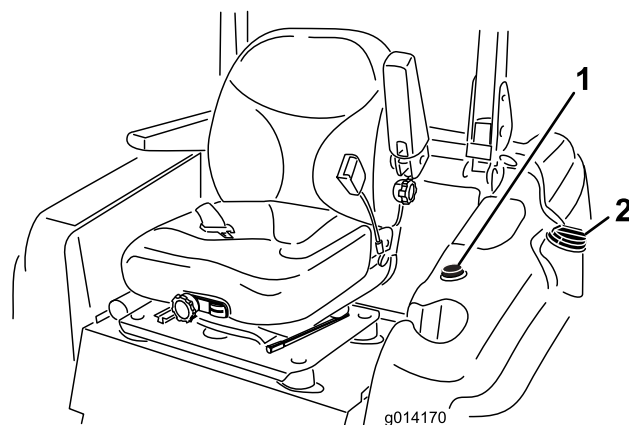

Figure 8

1. Fuel gauge                      2. Fuel-tank cap

## Throttle Lever

The throttle lever (Figure 7) controls the engine speed. Moving the throttle lever forward toward the FAST position increases the engine speed. Moving it rearward toward the SLOW position decreases the engine speed. The throttle controls the speed of the PTO and, with the traction pedal, controls the ground speed of the machine. Always run the machine with the throttle in the FAST position when operating attachments.

## Hour Meter

The hour meter (Figure 7) records the number of hours that the engine has operated. It operates when the key switch is in the RUN position. Use these times for scheduling regular maintenance.

## Engine-Coolant-Temperature-Warning Light

This light glows and the attachment stops if the temperature of the engine coolant is high (Figure 7). If you do not stop the machine and the coolant temperature rises another 7°C (20° F), the engine shuts off.

**Important:** If the attachment shuts down and the temperature warning light is on, push the PTO knob down, drive the machine to a safe, flat area, move the throttle lever to the SLOW position, allow the traction pedal to move to the NEUTRAL position, and engage the parking brake. Allow the engine to idle for several minutes while it cools to a safe level. Shut off the engine and check the cooling system; refer to [Checking the Cooling System \(page 46\)](#).

## Glow-Plug-Indicator Light (Orange Light)

The glow-plug-indicator light (Figure 7) turns on when you turn the ignition switch to the ON position. It remains on for 6 seconds. When the light turns off, you can start the engine.

## Charge-Indicator Light

The charge-indicator light illuminates when the charging-system circuit malfunctions (Figure 7).

## Oil-Pressure Warning Light

The oil-pressure warning light glows if the engine-oil pressure drops below a safe level (Figure 7). If the oil pressure is low, shut off the engine and determine the cause. Repair the engine-oil system before you start the engine again.

## Steering Selector Switch

### 4-Wheel Drive Machines Only

Press the steering selector switch to the rear to engage 4-wheel steering and forward to return to 2-wheel steering (Figure 7).

## Diagnostic Light

### 4-Wheel Drive Machines Only

The diagnostic light illuminates when the system detects a fault (Figure 7).

## Understanding the Diagnostic Light

### 4-Wheel Drive Machines Only

The machine comes with a diagnostic light that indicates if the electronic controller senses an electronic malfunction. The diagnostic light is located on the control panel (Figure 9). When the electronic controller is functioning correctly and the key switch is moved to the ON position, the controller diagnostic light turns on for 3 seconds and turn off to indicate that the light is working properly. If the engine shuts off, the light turns on steady until you change the key position. The light blinks if the controller detects a malfunction in the electrical system. The light stops blinking and automatically resets when you turn the key switch to the OFF position when the fault has been resolved.

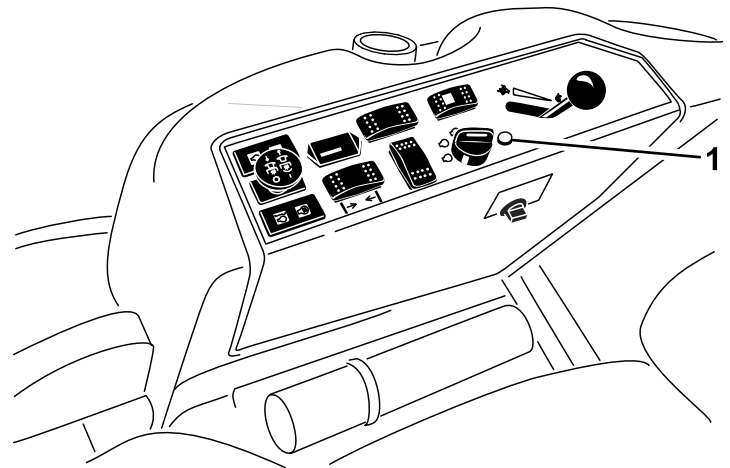

g014333

g014333

Figure 9

1. Diagnostic light

When the controller diagnostic light blinks, 1 of the following problems has been detected by the controller:

- An output has been shorted.
- An output has an open circuit.

Use the diagnostic ace display to determine which output is malfunctioning.

If the diagnostic light does not come on when the key switch is in the ON position, this indicates that the electronic controller is not operating. Possible causes are as follows:

- The light is burned out.
- The fuses are blown.
- The electronic controller is not functioning correctly.

Check the electrical connections, input fuses, and diagnostic light bulb to determine the malfunction. Ensure that the loop-back connector is secured to the wire-harness connector.



## Diagnostic Ace Display

The machine comes with an electronic controller which controls most of the machine functions. The controller determines what function is required for various input switches (e.g., seat switch and key switch) and turns on the outputs to actuate solenoids or relays for the requested machine function.

For the electronic controller to control the machine as desired, each of the input switches, output solenoids, and relays must be connected and functioning properly.

Use the Diagnostic ACE display tool and the overlay to help verify and correct electrical functions of the machine. Contact your authorized Toro distributor for assistance.

## Cab Controls

### Model with Cab Only

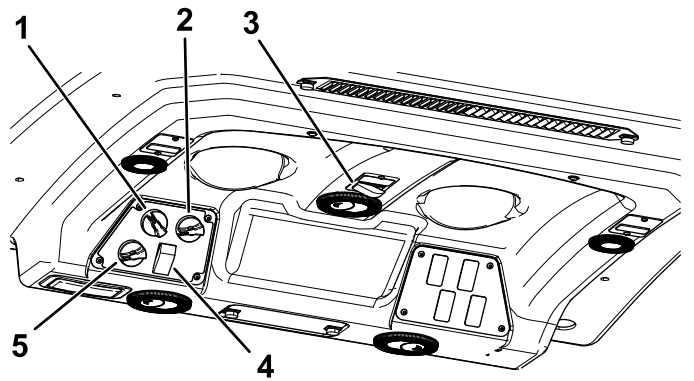

Figure 10

g198816

- |                            |                              |
|----------------------------|------------------------------|
| 1. Fan control             | 4. Air-conditioning switch   |
| 2. Temperature control     | 5. Air-recirculation control |
| 3. Windshield-wiper switch |                              |

### Air-Recirculation Control

Sets the cab to either recirculate the air in the cabin or to draw air into the cabin from outside (Figure 10).

- Set it to recirculate the air when using the air-conditioning.
- Set it to draw air in when using the heater or fan.

### Fan-Control Knob

Rotate the fan-control knob to regulate the speed of the fan (Figure 10).

### Temperature-Control-Knob

Rotate the temperature-control knob to regulate the air temperature in the cab (Figure 10).

### Windshield-Wiper Switch

Use this switch to turn the wind shield wipers on or off (Figure 10).

### Air-Conditioning Switch

Use this switch to turn the air conditioning on or off (Figure 10).

### Windshield Latch

Lift up the latch to open the windshield (Figure 11). Press in the latch to lock the windshield in the open position. Pull out and down on the latch to close and secure the windshield.

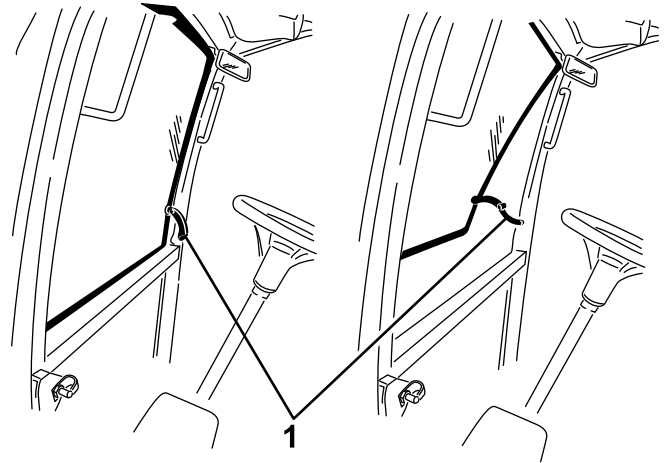

Figure 11

g196911

1. Windshield latch

### Rear Window Latch

Lift up the latches to open the rear window. Press in on the latch to lock the window in OPEN position. Pull out and down on the latch to close and secure the window (Figure 11).

**Important:** Close the rear window before opening the hood or damage may occur to the hood or rear window.

# Specifications

**Note:** Specifications and design are subject to change without notice.

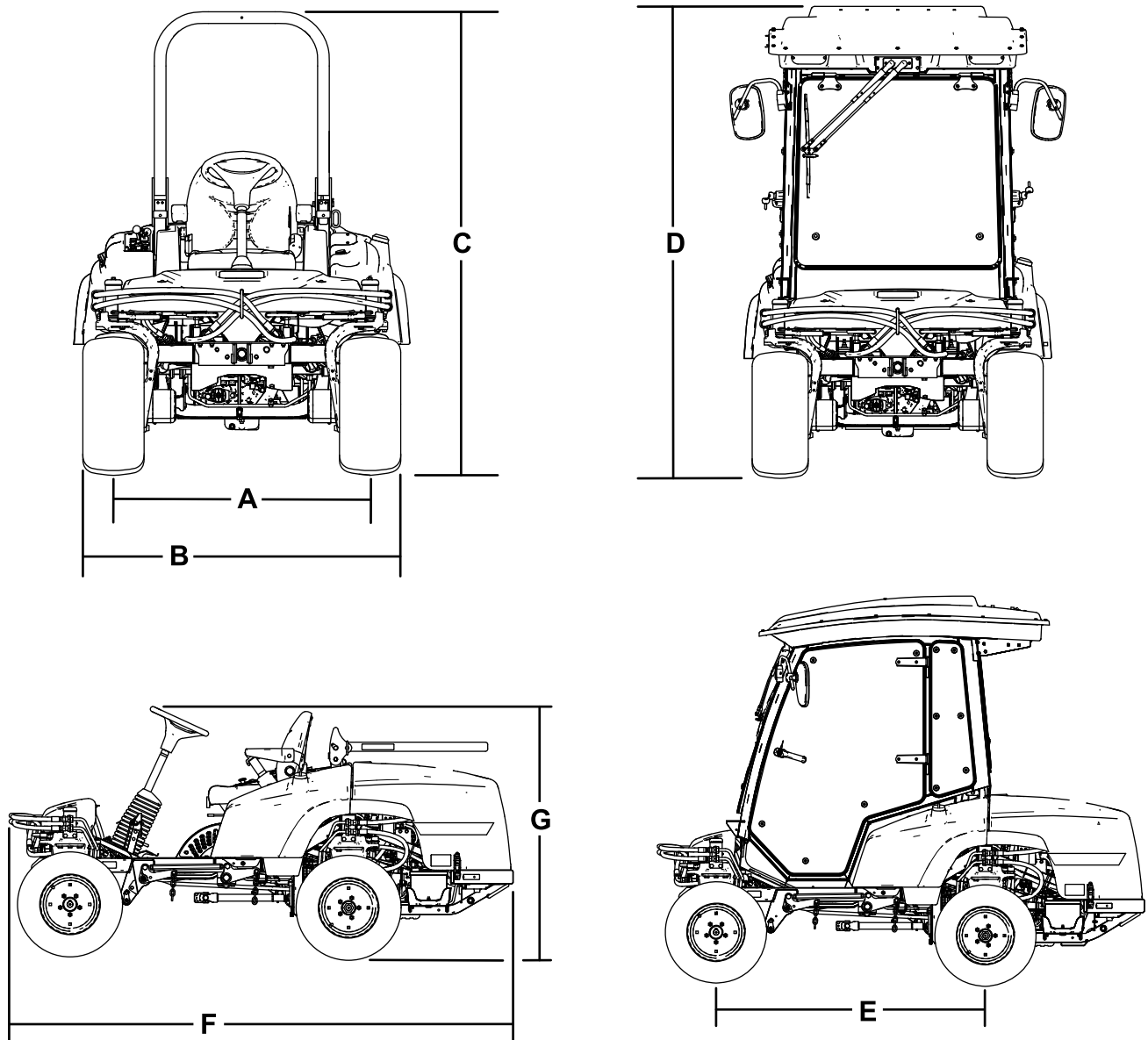

Figure 12

g197702

Description	Figure 12 reference	Dimension or Weight
Height with roll bar up	C	201 cm (79 inches)
Height with roll bar down	G	137 cm (54 inches)
Height with cab	D	225 cm (88-1/2 inches)
Overall length	F	276 cm (108-1/2 inches)
Overall width	B	147 cm (58 inches)
Wheel base	E	155 cm (61 inches)
Wheel tread (tire center to center) rear	A	112 cm (44 inches)
Ground clearance		15 cm (6 inches)

## Weight of the Machine with Mower Decks

	4-Wheel Drive Machine with ROPS	Machine with Cab	2-Wheel Drive Machine with ROPS
No mower deck	1,134 kg (2,500 lb)	1,361 kg (3,000 lb)	1,088 kg (2,398 lb)
72 inch side discharge mower deck	1,344 kg (2,964 lb)	1,571 kg (3,464 lb)	1,298 kg (2,862 lb)
72 inch base mower deck	1,323 kg (2,916 lb)	1,549 kg (3,416 lb)	1,276 kg (2,814 lb)
62 inch base mower deck	1,305 kg (2,878 lb)	1,532 kg (3,378 lb)	1,259 kg (2,776 lb)
100 inch rear discharge mower deck	1,492 kg (3,290 lb)	1,719 kg (3,790 lb)	1,446 kg (3,188 lb)

## Attachments/Accessories

A selection of Toro approved attachments and accessories is available for use with the machine to enhance and expand its capabilities. Contact your Authorized Service Dealer or authorized Toro distributor or go to [www.Toro.com](http://www.Toro.com) for a list of all approved attachments and accessories.

To ensure optimum performance and continued safety certification of the machine, use only genuine Toro replacement parts and accessories. Replacement parts and accessories made by other manufacturers could be dangerous, and such use could void the product warranty.

# Operation

**Note:** Determine the left and right sides of the machine from the normal operating position.

## Before Operation

### Before Operation Safety

#### General Safety

- Never allow children or untrained people to operate or service the machine. Local regulations may restrict the age of the operator. The owner is responsible for training all operators and mechanics.
- Become familiar with the safe operation of the equipment, operator controls, and safety signs.
- Know how to stop the machine and shut off the engine quickly.
- Check that operator-presence controls, safety switches, and shields are attached and functioning properly. Do not operate the machine unless they are functioning properly.
- Before mowing, always inspect the machine to ensure that the blades, blade bolts, and cutting assemblies are in good working condition. Replace worn or damaged blades and bolts in sets to preserve balance.
- Inspect the area where you will use the machine and remove all objects that the machine could throw.

#### Fuel Safety

- Use extreme care in handling fuel. It is flammable and its vapors are explosive.
- Extinguish all cigarettes, cigars, pipes, and other sources of ignition.
- Use only an approved fuel container.
- Do not remove the fuel cap or fill the fuel tank while the engine is running or hot.
- Do not add or drain fuel in an enclosed space.
- Do not store the machine or fuel container where there is an open flame, spark, or pilot light, such as on a water heater or other appliance.
- If you spill fuel, do not attempt to start the engine; avoid creating any source of ignition until the fuel vapors have dissipated.

# Adding Fuel

## Fuel Specification

- Never use kerosene or gasoline instead of diesel fuel.
- Never mix kerosene or used engine oil with the diesel fuel.
- Never keep fuel in containers with zinc plating on the inside.
- Do not use fuel additives.

## Petroleum Diesel

**Cetane rating:** 40 or higher

**Sulfur content:** Low sulfur (<500 ppm) or ultra-low sulfur (<15 ppm)

## Fuel Table

Diesel fuel specification	Location
ASTM D975 No. 1-D S15 No. 2-D S15	USA
EN 590	European Union
ISO 8217 DMX	International
JIS K2204 Grade No. 2	Japan
KSM-2610	Korea

- Use only clean, fresh diesel fuel or biodiesel fuels.
- Purchase fuel in quantities that can be used within 180 days to ensure fuel freshness.

Use summer-grade diesel fuel (No. 2-D) at temperatures above -7°C (20°F) and winter-grade fuel (No. 1-D or No. 1-D/2-D blend) below that temperature.

**Note:** Use of winter-grade fuel at lower temperatures provides lower flash point and cold flow characteristics which eases starting and reduces fuel filter plugging.

Using summer-grade fuel above -7°C (20°F) contributes toward longer fuel pump life and increased power compared to winter-grade fuel.

## Using Biodiesel

This machine can also use a biodiesel-blended fuel of up to B20 (20% biodiesel, 80% petrodiesel).

**Sulfur content:** Ultra-low sulfur (<15 ppm)

**Biodiesel fuel specification:** ASTM D6751 or EN14214

**Blended fuel specification:** ASTM D975, EN590, or JIS K2204

**Important:** The petroleum diesel portion must be ultra-low sulfur.

Observe the following precautions:

- Biodiesel blends may damage painted surfaces.
- Use B5 (biodiesel content of 5%) or lesser blends in cold weather.
- Monitor seals, hoses, gaskets in contact with fuel as they may degrade over time.
- Fuel filter plugging may occur for a time after you convert to biodiesel blends.
- For more information on biodiesel, contact your authorized Toro distributor.

## Fuel Tank Capacity

51 L (13.5 US gallons)

## Filling the Fuel Tank

**Note:** If possible, fill the fuel tank after each use. This minimizes possible buildup of condensation inside the fuel tank.

Add fuel to the fuel tank until the level is even with the bottom of the filler neck. **Do not overfill the fuel tank.**

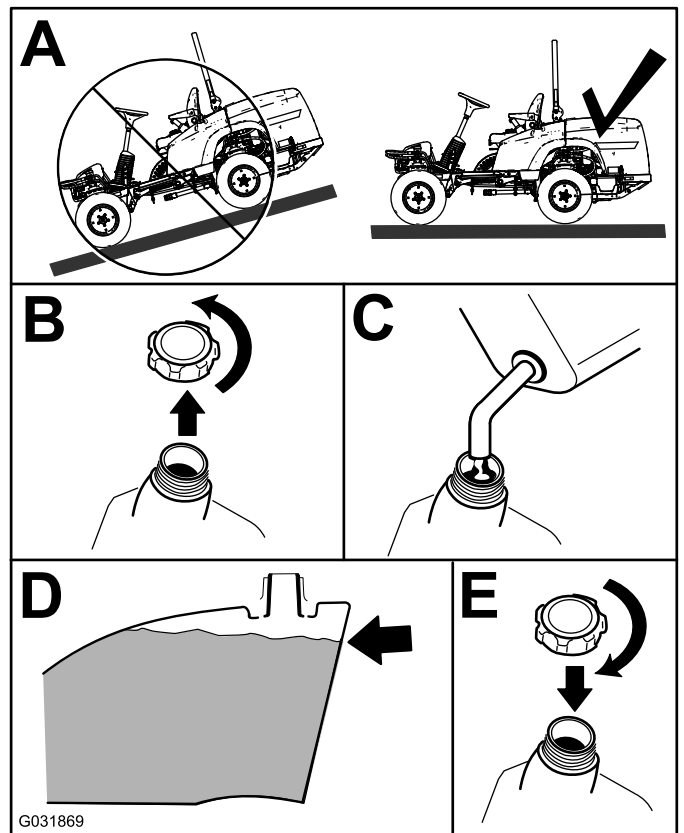

Figure 13

## Checking the Engine-Oil Level

Before you start the engine and use the machine, check the oil level in the engine crankcase; refer to [Checking the Engine-Oil Level \(page 37\)](#).

## Checking the Cooling System

Before you start the engine and use the machine, check the cooling system; refer to [Checking the Cooling System \(page 21\)](#).

## Checking the Hydraulic System

Before you start the engine and use the machine, check the hydraulic system; refer to [Checking the Hydraulic System \(page 50\)](#).

## The Safety-Interlock System

### **⚠ CAUTION**

**If the safety-interlock switches are disconnected or damaged, the machine could operate unexpectedly, causing personal injury.**

- **Do not tamper with the interlock switches.**
- **Check the operation of the interlock switches daily and replace any damaged switches before operating the machine.**

## Understanding the Safety Interlock System

The safety-interlock system is designed to prevent the engine from starting unless the following occurs:

- You are sitting on the seat or the parking brake is engaged.
- The power takeoff (PTO) is disengaged.
- The traction pedal is in the NEUTRAL position.
- The engine temperature is below the maximum operating temperature.

The safety-interlock system is also designed to shut off the engine when you move the traction pedal from

the NEUTRAL position with the parking brake engaged. If you rise from the seat when the PTO is engaged there is a 1-second delay and then the engine shuts off.

## Testing the Safety-Interlock System

**Service Interval:** Before each use or daily

If the safety system does not operate as described below, have an authorized Toro distributor repair the system immediately.

1. Sit on the seat, engage the parking brake, and move the PTO to the ON position. Try starting the engine: The engine should not start.
2. Sit on the seat, engage the parking brake, move the PTO to the OFF position, and engage the traction pedal. Try starting the engine: The engine should not start.
3. Sit on the seat, engage the parking brake, move the PTO switch to the OFF position, and allow the traction pedal to return to the NEUTRAL position. Start the engine. While the engine is running, release the parking brake, engage the PTO and rise slightly from the seat: The engine should shut off within 2 seconds.
4. With an empty seat, engage the parking brake, move the PTO switch to the OFF position and move the traction pedal to the NEUTRAL position. Start the engine. While the engine is running, engage the traction pedal; the engine should shut off within 2 seconds.
5. With an empty seat, disengage the parking brake, move the PTO switch to the OFF position, and allow the traction pedal to return to the NEUTRAL position. Try starting the engine: The engine should not start.

## Positioning the Standard Seat

### Changing the Seat Position

The seat can move forward and backward. Position the seat where you have the best control of the machine and are most comfortable.

1. To adjust the seat, move the lever sideways to unlock the seat ([Figure 14](#)).

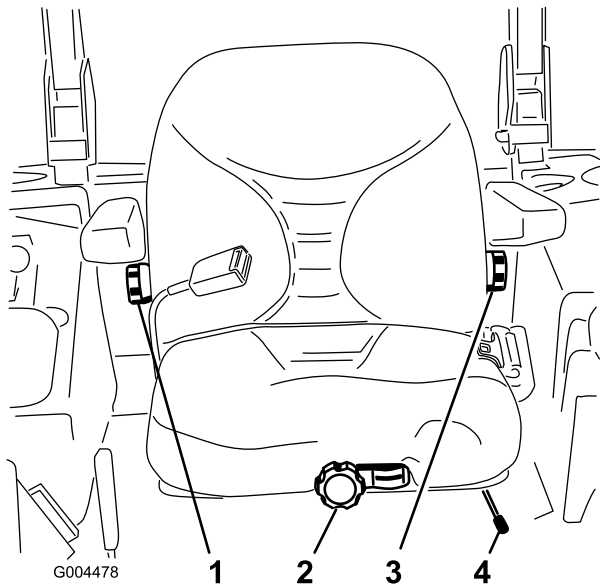

**Figure 14**

- |                         |                                   |
|-------------------------|-----------------------------------|
| 1. Backrest knob        | 3. Lumbar-support-adjustment knob |
| 2. Seat-suspension knob | 4. Seat-position-adjustment lever |

- Slide the seat to the desired position and release the lever to lock the seat in position.
- Verify that the seat has locked into place by attempting to move it back and forth.

## Changing the Seat Suspension

You can adjust the seat to provide a smooth and comfortable ride. Position the seat where you are most comfortable.

Without sitting on the seat, turn the knob in front in either direction to provide the best comfort (Figure 14).

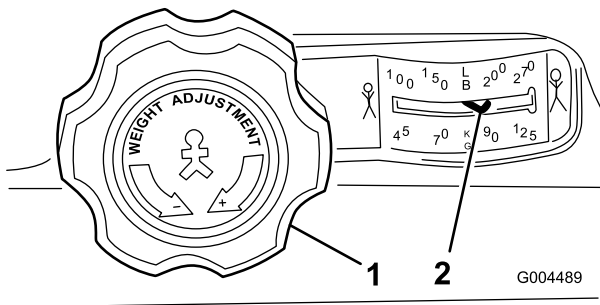

**Figure 15**

- |                         |                            |
|-------------------------|----------------------------|
| 1. Seat-suspension knob | 2. Operator-weight setting |
|-------------------------|----------------------------|

## Changing the Back Position

You can adjust the back of the seat to provide a comfortable ride. Position the back of the seat where it is most comfortable.

To adjust the back of the seat, turn the knob, located under the right-side armrest, in either direction to provide the best comfort (Figure 14).

## Changing the Lumbar Support

You can adjust the back of the seat to provide a customized lumbar support for your lower back.

To adjust the back of the seat, turn the knob, under the left-side armrest, in either direction to provide the best comfort (Figure 14).

## Raising and Lowering the Seat

To access the hydraulic and other systems under the seat, you must unlatch the seat and swing it forward.

- Move the seat latch, located on the left side of the seat, rearward to unlatch the seat and pull forward on the top of the seat (Figure 16).

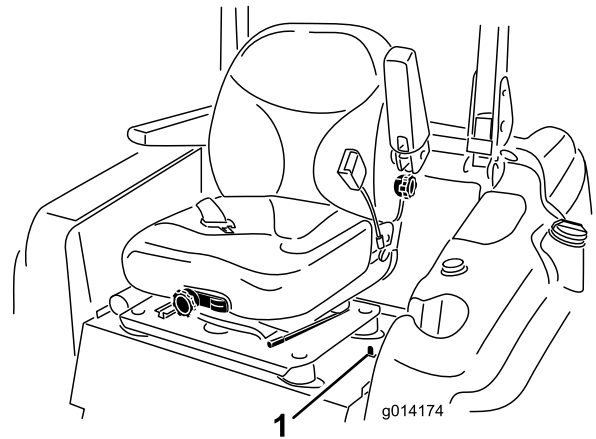

**Figure 16**

- To lower the seat, pull up the seat-latch-release bar and lower the seat into the locked position.

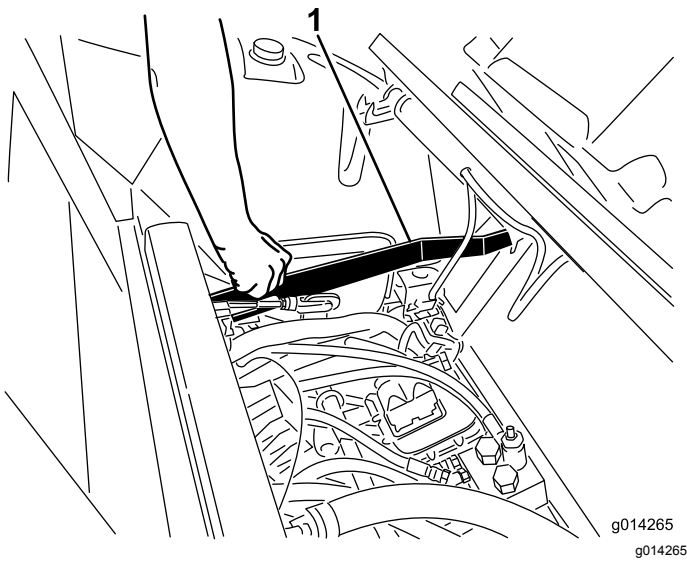

**Figure 17**

1. Seat-latch-release bar

## ***During Operation***

### **During Operation Safety**

#### **General Safety**

- The owner/operator can prevent and is responsible for accidents that may cause personal injury or property damage.
- Wear appropriate clothing, including eye protection; long pants; substantial, slip-resistant footwear; and hearing protection. Tie back long hair and do not wear loose jewelry.
- Use your full attention while operating the machine. Do not engage in any activity that causes distractions; otherwise, injury or property damage may occur.
- Do not operate the machine while ill, tired, or under the influence of alcohol or drugs.
- Never carry passengers on the machine and keep bystanders and pets away from the machine during operation.
- Operate the machine only in good visibility to avoid holes or hidden hazards.
- Before you start the engine, ensure that all drives are in neutral, the parking brake is engaged, and you are in the operating position.
- Keep your hands and feet away from rotating parts. Keep clear of the discharge opening at all times.
- Look behind and down before backing up to be sure of a clear path.

- Use care when approaching blind corners, shrubs, trees, or other objects that may obscure your vision.
- Stop the blades whenever you are not mowing.
- Stop the machine, remove the key, and wait for all moving parts to stop before inspecting the attachment after striking an object or if there is an abnormal vibration in the machine. Make all necessary repairs before resuming operation.
- Slow down and use caution when making turns and crossing roads and sidewalks with the machine. Always yield the right-of-way.
- Disengage the drive to the cutting unit, shut off the engine, remove the key, and wait for all moving parts to stop before adjusting the height of cut (unless you can adjust it from the operating position).
- Never run an engine in an area where exhaust gasses are enclosed.
- Never leave a running machine unattended.
- Before leaving the operating position (including to empty the catchers or to unclog the chute), do the following:
  - Park the machine on level ground.
  - Disengage the power takeoff and lower the attachments.
  - Engage the parking brake.
  - Shut off the engine and remove the key.
  - Wait for all moving parts to stop.
- Do not operate the machine when there is the risk of lightning.
- Do not use the machine as a towing vehicle.
- Use accessories, attachments, and replacement parts approved by The Toro® Company only.

### **Rollover Protection System (ROPS) Safety**

- **Do not** remove the ROPS from the machine.
- Ensure that the seat belt is attached and that you can release it quickly in an emergency.
- Check carefully for overhead obstructions and do not contact them.
- Keep the ROPS in safe operating condition by thoroughly inspecting it periodically for damage and keeping all the mounting fasteners tight.
- Replace a damaged ROPS components. Do not repair or alter them.

#### **Machines with Cabs**

- The ROPS is an integral and effective safety device.

- A cab installed by Toro is a roll bar.
- Always wear your seat belt.

## Machines with a Foldable Roll Bar

- Always use the seat belt with the roll bar in the raised position.
- The ROPS is an integral safety device. Keep a folding roll bar in the raised and locked position, and use the seat belt when operating the machine with the roll bar in the raised position.
- Lower a folding roll bar temporarily only when necessary. Do not wear the seat belt when the roll bar is folded down.
- Be aware that there is no rollover protection when a folded roll bar is in the down position.
- Check the area that you will be mowing and never fold down a folding roll bar in areas where there are slopes, drop-offs, or water.

## Slope Safety

- Slopes are a major factor related to loss of control and rollover accidents, which can result in severe injury or death. You are responsible for safe slope operation. Operating the machine on any slope requires extra caution.
- Evaluate the site conditions to determine if the slope is safe for machine operation, including surveying the site. Always use common sense and good judgment when performing this survey.
- Review the slope instructions listed below for operating the machine on slopes and to determine whether you can operate the machine in the conditions on that day and at that site. Changes in the terrain can result in a change in slope operation for the machine.
- Avoid starting, stopping, or turning the machine on slopes. Avoid making sudden changes in speed or direction. Make turns slowly and gradually.
- Do not operate a machine under any conditions where traction, steering, or stability is in question.
- Remove or mark obstructions such as ditches, holes, ruts, bumps, rocks, or other hidden hazards. Tall grass can hide obstructions. Uneven terrain could overturn the machine.
- Be aware that operating the machine on wet grass, across slopes, or downhill may cause the machine to lose traction. Loss of traction to the drive wheels may result in sliding and a loss of braking and steering.
- Use extreme caution when operating the machine near drop-offs, ditches, embankments, water hazards, or other hazards. The machine could suddenly roll over if a wheel goes over the edge

or the edge caves in. Establish a safety area between the machine and any hazard.

- Identify hazards at the base of the slope. If there are hazards, mow the slope with a pedestrian-controlled machine.
- If possible, keep the cutting unit(s) lowered to the ground while operating on slopes. Raising the cutting unit(s) while operating on slopes can cause the machine to become unstable.
- Use extreme caution with grass-collection systems or other attachments. These can change the stability of the machine and cause a loss of control. Always keep the machine in gear when going down slopes. Do not coast downhill (applicable only to gear-drive units).

## Using the Rollover-Protection System (ROPS)

### ⚠ WARNING

**A rollover accident can cause injury or death.**

- **Keep the roll bar in the raised locked position.**
- **Use the seat belt.**
- **Ensure that the seat plate is secured with the seat latch.**

### ⚠ WARNING

**You have no rollover protection when the roll bar is in the down position.**

- **Lower the roll bar only when necessary.**
- **Do not wear the seat belt when the roll bar is in the down position.**
- **Drive slowly and carefully.**
- **Raise the roll bar as soon as clearance permits.**
- **Check carefully for overhead clearances (i.e., branches, doorways, electrical wires) before driving under any objects and do not contact them.**

## Raising the Roll Bar

**Important:** Always use the seat belt when the roll bar is in the raised and locked position.

1. Ensure that the seat is secured with the seat latch.
2. Remove the 2 hairpins and remove the 2 pins (Figure 18).



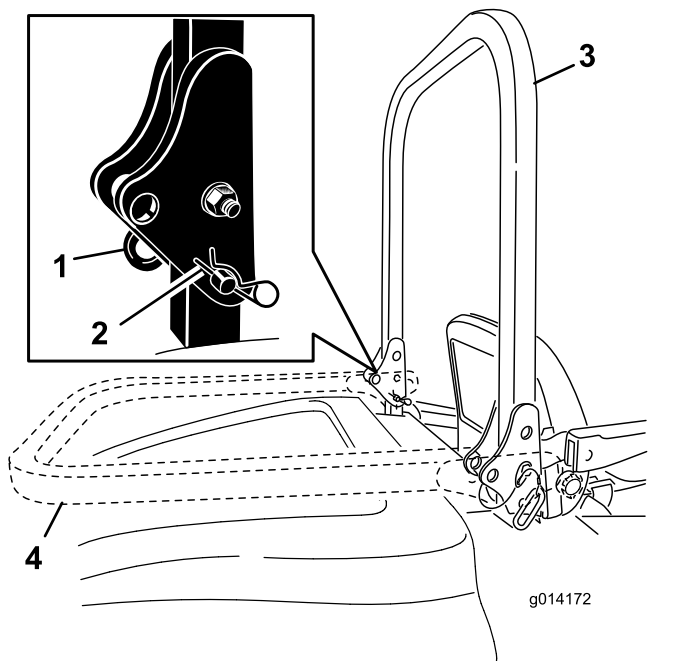

**Figure 18**

- |            |                                |
|------------|--------------------------------|
| 1. Pin     | 3. Roll bar (raised position)  |
| 2. Hairpin | 4. Roll bar (lowered position) |

3. Raise the roll bar to the upright position (Figure 18).
4. Secure the roll bar with the 2 pins and 2 hairpins (Figure 18).

### Lowering the Roll Bar

**Important:** Do not use the seat belt when the roll bar is in the lowered position.

1. Remove the hairpins, push the roll bar forward against the springs, and remove the 2 pins (Figure 18).
2. Lower the roll bar to the down position (Figure 18).
3. Install the 2 pins into the pivot plates and secure the pins with the 2 hairpins (Figure 18).

## Starting the Engine

1. If installed, raise the roll bar up and lock it into place, sit on the seat, and fasten the seat belt.
2. Ensure that the traction pedal is in the NEUTRAL position.
3. Engage the parking brake.
4. Move the power-takeoff (PTO) switch to the OFF position (Figure 19).

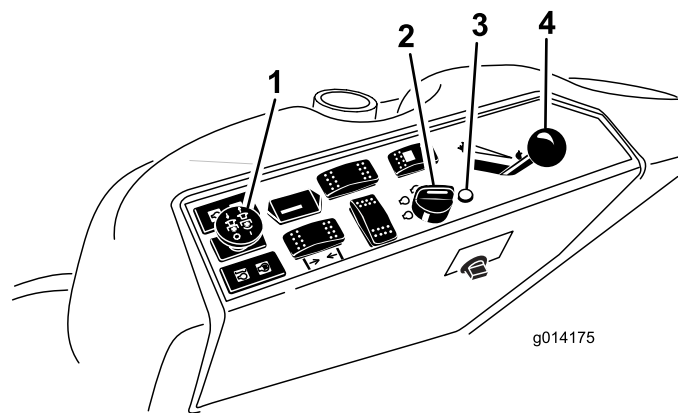
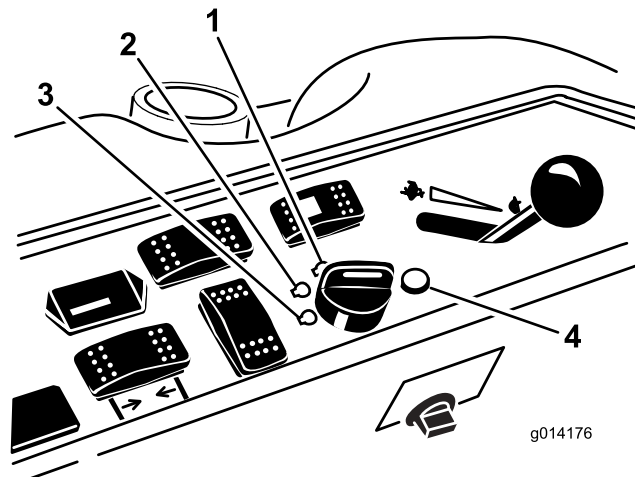

**Figure 19**

- |                               |                    |
|-------------------------------|--------------------|
| 1. Power-takeoff switch (PTO) | 3. Glow-plug light |
| 2. Ignition switch            | 4. Throttle lever  |

5. Move the throttle lever midway between the FAST and SLOW positions (Figure 19).
6. Turn the ignition key clockwise to the RUN position (Figure 20).

The glow-plug-indicator light should turn on for 6 seconds.



**Figure 20**

- |                  |                              |
|------------------|------------------------------|
| 1. Start         | 3. Off                       |
| 2. Run/glow plug | 4. Glow-plug-indicator light |

7. After the glow-plug-indicator light turns off, turn the key to the START position. When the engine starts, release the key.

**Important:** Use starting cycles of no more than 15 seconds per minute to avoid overheating the starter motor.

**Note:** You may need to repeat this procedure when starting the engine for the first time after adding fuel to an empty fuel system.

8. Leave the throttle midway between the SLOW and FAST positions until the engine and the hydraulic system warm up.

**Important:** When you start the engine for the first time, change the engine oil, or overhaul the engine, transmission, or wheel motor, operate the machine with the throttle lever in the SLOW position in both the forward and reverse directions for 1 to 2 minutes. Also, operate the lift lever and PTO lever to ensure that all parts are operating properly. Then shut off the engine and check the fluid levels, check for oil leaks, loose parts, and any other problems.

## Shutting Off the Engine

1. Park the machine on a level surface.
2. Disengage the PTO, make sure that the traction pedal is in the NEUTRAL position, engage the parking brake, and move the engine-speed switch to the idle position.
3. Let the engine idle for 60 seconds.
4. Turn the key to the OFF position.
5. Remove the key to prevent the engine from accidentally starting and before you transport or store the machine.

**Note:** Remove the key; otherwise, the fuel pump or accessories may run and cause the battery to lose charge.

### ⚠ CAUTION

Children or bystanders may be injured if they move or attempt to operate the machine while it is unattended.

Always remove the key and engage the parking brake when leaving the machine unattended, even for a short period of time between operation.

## Driving the Machine

The throttle control regulates the engine speed as measured in rpm (revolutions per minute). Place the throttle control in the FAST position for best performance. Always operate the throttle in the FAST position when mowing.

## Stopping the Machine

To stop the machine, release the traction pedal to the NEUTRAL position.

Engage the parking brake whenever you leave the machine and remove the key.

## Selecting the Steering Mode

For maximum trimming and minimum turf damage, operate the machine in the 4-wheel-steering mode. However, when transporting the machine on roads or trails, switch the machine into 2-wheel-steering mode.

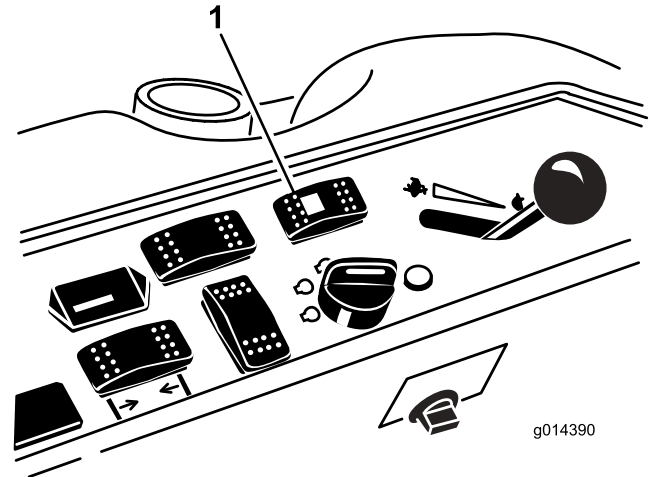

Figure 21

1. Steering-selector switch

## Switching from 4-Wheel Steering to 2-Wheel Steering

Press the steering-selector switch (Figure 21) to the forward position. When the wheels are not aligned in the forward position, the green light flashes and the machine remains in the 4-wheel-steering mode until the 4 tires point straight ahead. Turn the steering wheel slowly to straighten out the wheels until the green light stops flashing and remains on. When the switch light is solid green, the machine is in 2-wheel steering.

**Note:** If you turn the steering wheel too briskly, steering misalignment may occur.

## Switching from 2-Wheel Steering to 4-Wheel Steering

Press the steering-selector switch (Figure 21) to the rearward position. When the front wheels are not aligned in the forward position, the green light flashes and the machine remains in 2-wheel-steering mode until the 4 tires point straight ahead. Turn the steering wheel slowly to straighten out the wheels until the

green light stops flashing and remains off. When the switch light is continuously off, the machine is in the 4-wheel-steering mode.

**Note:** If you turn the steering wheel too briskly, steering misalignment may occur.

**Note:** If the steering system is misaligned after repeated 2-wheel-steering to 4-wheel-steering engagements, refer to [Correcting the Steering Misalignment \(page 45\)](#).

## Operating the Mower Deck or Attachment

### Raising and Lowering the Mower/Attachment

The deck-lift switch raises and lowers the mower deck/attachment ([Figure 22](#)). The engine must be running for you to use this switch.

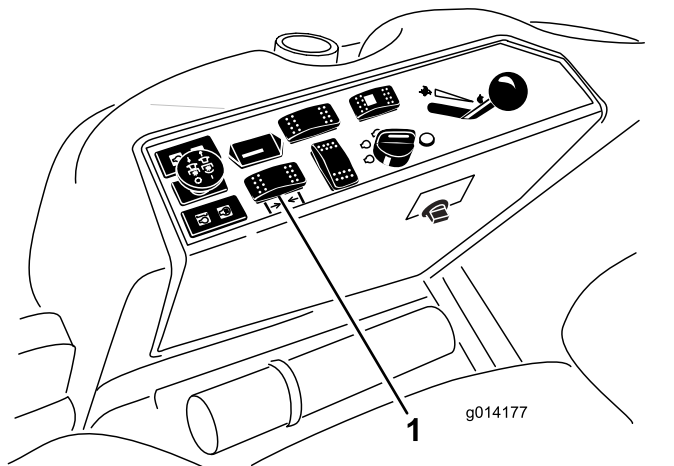

**Figure 22**

1. Deck-lift switch

- To lower the mower deck/attachment, push the switch forward.
- To raise the mower deck/attachment, push the switch rearward.

**Important:** Do not continue to hold the switch back after the mower/attachment is fully raised. Doing so causes damage the hydraulic system.

**Note:** To lock the mower deck/attachment in the raised position, raise the deck/attachment past the 15 cm (6 inch) position, remove the height-of-cut stop pin, and insert the pin into the 15 cm (6 inch) height-of-cut position; refer to [Adjusting the Height of Cut \(page 27\)](#).

## Engaging the Power Takeoff (PTO)

The power-takeoff (PTO) switch starts and stops the mower blades and some powered attachments.

1. If the engine is cold, allow the engine to warm up 5 to 10 minutes before engaging the PTO.
2. While seated in the seat, ensure that the traction pedal is in the NEUTRAL position and that the engine is at full throttle.
3. Pull up the PTO switch to engage it ([Figure 23](#)).

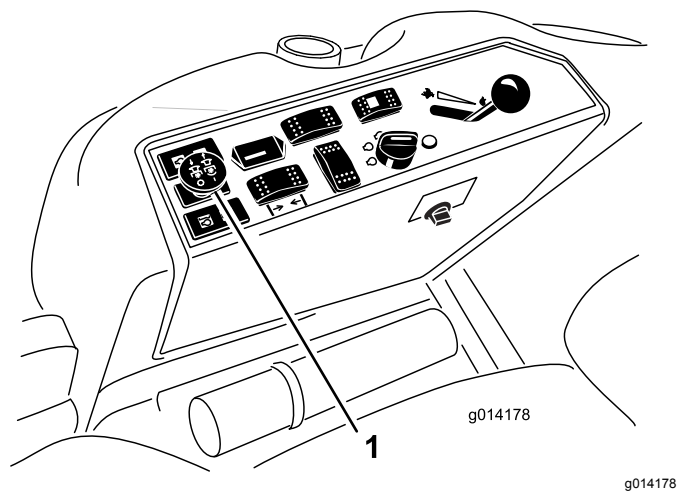

**Figure 23**

1. PTO switch

## Disengaging the PTO

To disengage, push the PTO switch to the OFF position.

## Adjusting the Height of Cut

You can adjust the height of cut from 2.5 to 15.8 cm (1 to 6 inches) in 6 mm (1/4 inch) increments by relocating the height-of-cut pin into different hole locations.

1. With the engine running, push back the deck-lift switch until the mower deck is fully raised, and **release the switch immediately** as shown in [Figure 24](#).
2. Rotate the height-of-cut pin until the nub on it lines up with the slots in the holes in the height-of-cut bracket and remove it ([Figure 24](#)).
3. Select a hole in the height-of-cut bracket corresponding to the desired height of cut, insert the pin, and rotate it down to lock it in place ([Figure 24](#)).

**Note:** There are 4 rows of hole positions ([Figure 24](#)). The top row gives you the height of cut listed above the pin. The second row down gives you the height listed plus 6 mm (1/4 inch).

The third row down gives you the height listed plus 12 mm (1/2 inch). The bottom row gives you the height listed plus 18 mm (3/4 inch). For the 15.8 cm (6 inches) position, there is only 1 hole, located in the second row. This does not add 6 mm (1/4 inch) to the 15.8 cm (6 inches) position.

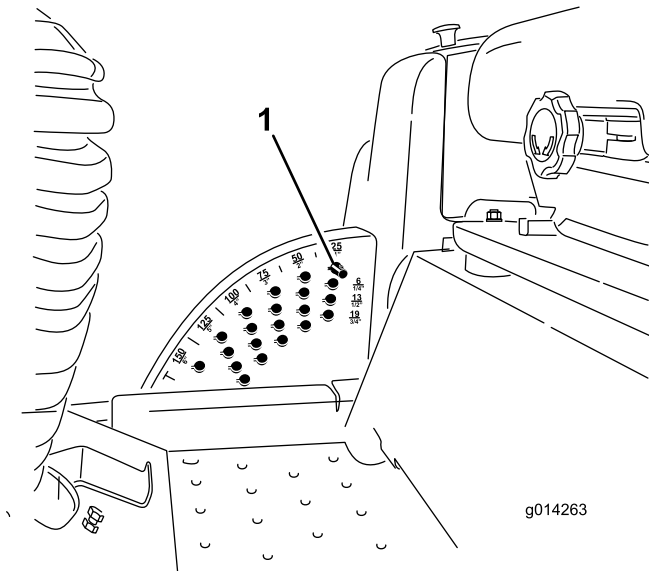

Figure 24

1. Height-of-cut pin

4. Adjust the anti-scalp rollers and skids as required.

## Operating Tips

### Using the Fast Throttle Setting

To maintain enough power for the machine and deck while mowing, operate the engine at the fast throttle position and adjust your ground speed for conditions.

### Selecting the Ground Speed

To improve cut quality, use a slower ground speed. Decrease the ground speed as the load on the cutting blades increases, and increase ground speed as the load on the blades decreases.

### Alternating Mowing Direction

Alternate mowing direction to avoid making ruts in the turf over time. This also helps the disperse clippings, which enhances decomposition and fertilization.

### Avoiding a Low Cut

If the machine cutting width is wider than the machine that you previously used, raise the cutting height to ensure that uneven turf is not cut too short.

## Select the Proper Height-of-Cut Setting to Suit Conditions

Remove approximately 25 mm (1 inch) or no more than 1/3 of the grass blade when cutting. In exceptionally lush and dense grass, you may need to slow down the forward speed and/or raise the height-of-cut to the next higher setting.

**Important:** If you are cutting more than 1/3 of the grass blade, or are mowing in sparse long grass or dry conditions, use the flat sail of the blades to reduce air-borne chaff, debris, and strain on the deck-drive components.

## Cutting Long Grass

If you allow the grass to grow slightly longer than normal, or if the grass contains a high degree of moisture, raise the cutting height to a higher setting and cut the grass at this setting. Then cut the grass again using the lower, normal setting.

## Keeping the Mower Clean

Clean clippings and dirt from the underside of the mower after each use. If grass and dirt build up inside the mower, cutting quality eventually becomes unsatisfactory.

To reduce the risk of fire hazard, keep the engine, muffler, battery compartment, parking brake, cutting units, and fuel storage compartment free of grass, leaves, or excessive grease. Clean up any spilled oil or fuel.

## Maintaining the Blades

- Maintain sharp blades throughout the cutting season. Sharp blades create a clean cut without tearing or shredding the grass blades. Tearing and shredding causes grass to turn brown at the edges, which slows growth and increases the chance of disease.
- Check the blades daily for sharpness and for any wear or damage. Sharpen the blades as necessary.
- If a blade is damaged or worn, replace it immediately with a genuine Toro replacement blade. Refer to the cutting unit *Operator's Manual* for instructions to replace the blade.

# After Operation

## After Operation Safety

- Clean grass and debris from the cutting units, mufflers, and engine compartment to help prevent fires. Clean up oil or fuel spills.
- If the cutting units are in the transport position, use the positive mechanical lock (if available) before you leave the machine unattended.
- Allow the engine to cool before storing the machine in any enclosure.
- Remove the key and shut off the fuel (if equipped) before storing or transporting the machine.
- Never store the machine or fuel container where there is an open flame, spark, or pilot light, such as on a water heater or on other appliances.
- Keep all parts of the machine in good working condition and all hardware tightened, especially blade-attachment hardware.
- Maintain and clean the seat belt(s) as necessary
- Replace all worn or damaged decals.

## Pushing the Machine by Hand

If the machine stalls or runs out of fuel, you may need to push it. You must first open both of the hydraulic bypass valves.

**Important:** Always push the machine by hand and never a long distance. Never tow the machine, because damage to the hydraulic system may occur.

## Pushing the Machine

1. Disengage the power takeoff (PTO), turn the key to the OFF position, remove the key, and engage the parking brake.
2. Lift the seat.
3. Rotate each bypass valve counterclockwise 1 turn (Figure 25).

**Note:** This allows hydraulic fluid to bypass the pump, enabling the wheels to turn.

**Important:** Do not rotate the bypass valves more than 1 turn. This prevents the valves from coming out of the body and causing fluid to run out.

4. Disengage the parking brake before pushing the machine.

## Changing to Machine Operation

1. Rotate each bypass valve clockwise 1 turn and hand tighten them (Figure 25).
- Note:** Do not overtighten the bypass valves.
2. Torque the valves approximately 8 N·m (71 in-lb) as shown in Figure 25.

**Note:** The machine does not drive unless the bypass valves are turned in.

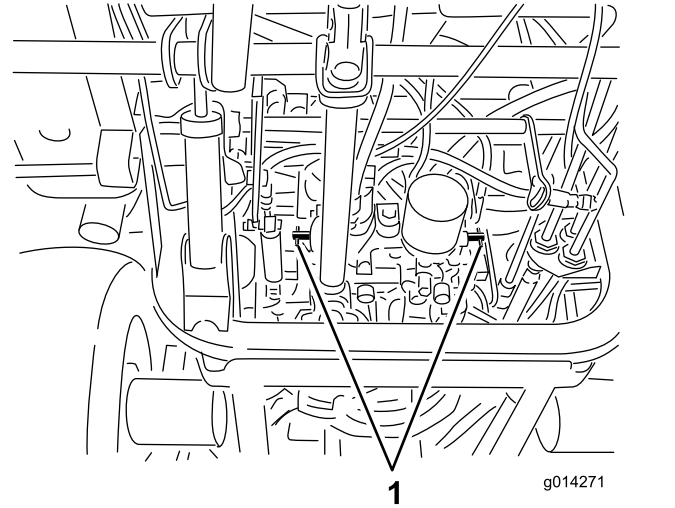

Figure 25

1. Bypass valves

## Hauling the Machine

- Remove the key and shut off the fuel (if equipped) before storing or transporting the machine.
- Use care when loading or unloading the machine into a trailer or a truck.
- Use full-width ramps for loading the machine into a trailer or a truck.
- Tie the machine down securely.

# Locating the Tie-Down Points

There are tie downs located at the front and rear sides of the machine (Figure 26).

**Note:** Use properly-rated DOT-approved straps in 4 corners to tie down the machine.

- 2 on the front of the operator's platform
- Rear tire

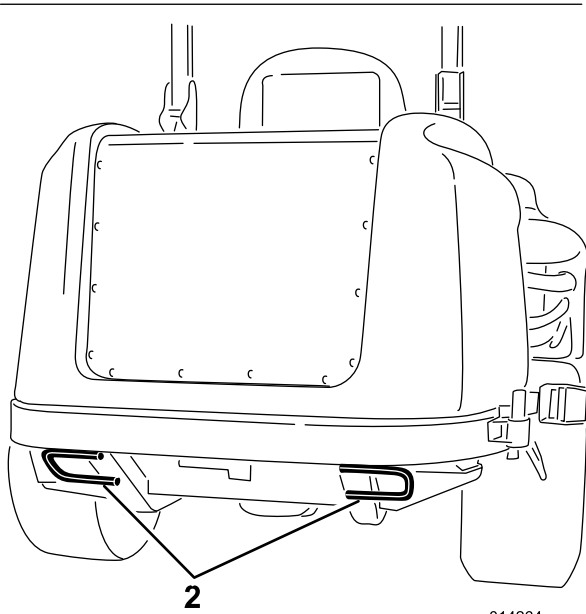
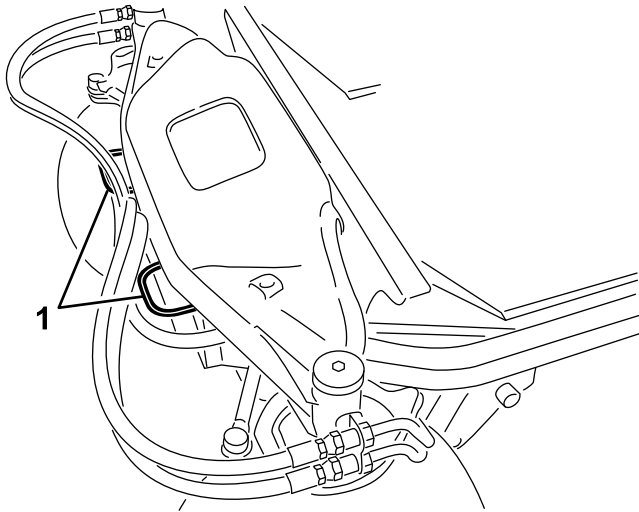

**Figure 26**

1. Front tie-down point      2. Rear tie-down point

# Maintenance

**Note:** Determine the left and right sides of the machine from the normal operating position.

Download a free copy of the electrical or hydraulic schematic by visiting [www.Toro.com](http://www.Toro.com) and searching for your machine from the Manuals link on the home page.

## Maintenance Safety

- Before adjusting, cleaning, repairing, or leaving the machine, do the following:
  - Park the machine on a level surface.
  - Move the throttle switch to the low-idle position.
  - Disengage the cutting units.
  - Lower the cutting units.
  - Ensure that the traction is in neutral.
  - Engage the parking brake.
  - Shut off the engine and remove the key.
  - Wait for all moving parts to stop.
- Allow machine components to cool before performing maintenance.
- If the cutting units are in the transport position, use the positive mechanical lock (if available) before you leave the machine unattended.
- If possible, do not perform maintenance while the engine is running. Keep away from moving parts.
- Use jack stands to support the machine or components when required.
- Carefully release pressure from components with stored energy.

## Recommended Maintenance Schedule(s)

Maintenance Service Interval	Maintenance Procedure
After the first 10 hours	<ul style="list-style-type: none"> <li>• Check the tension on the alternator belt.</li> <li>• Check the belt tension on the air-conditioning compressor.</li> <li>• Torque the wheel-lug nuts.</li> </ul>
After the first 50 hours	<ul style="list-style-type: none"> <li>• Change the engine oil and filter.</li> </ul>
After the first 200 hours	<ul style="list-style-type: none"> <li>• Change the hydraulic fluid and filter.</li> </ul>
Before each use or daily	<ul style="list-style-type: none"> <li>• Test the safety-interlock system.</li> <li>• Check the engine-oil level.</li> <li>• Drain water or other contaminants from the water separator.</li> <li>• Check the engine-coolant level.</li> <li>• Clean the radiator with compressed air (do not use water). Clean the radiator more frequently in extremely dusty and dirty conditions.</li> <li>• Check the level of the hydraulic fluid.</li> <li>• Clean the attachment.</li> </ul>
Every 50 hours	<ul style="list-style-type: none"> <li>• Grease the bearing and bushing grease fittings. Grease the bearing and bushing grease fittings more frequently in extremely dusty and dirty conditions.</li> <li>• Check battery cable connections.</li> <li>• Check the tire pressure.</li> <li>• Clean the air-conditioning coil. Clean the air-conditioning coil more frequently in extremely dusty or dirty conditions.</li> </ul>
Every 100 hours	<ul style="list-style-type: none"> <li>• Check the tension on the alternator belt.</li> <li>• Check the belt tension on the air-conditioning compressor.</li> </ul>
Every 150 hours	<ul style="list-style-type: none"> <li>• Change the engine oil and filter.</li> </ul>
Every 200 hours	<ul style="list-style-type: none"> <li>• Inspect the cooling-system hoses and seals. Replace them if they are cracked or torn.</li> <li>• Torque the wheel-lug nuts.</li> </ul>
Every 250 hours	<ul style="list-style-type: none"> <li>• Clean the cab air filters; replace them if they are torn or excessively dirty.</li> </ul>

<b>Maintenance Service Interval</b>	<b>Maintenance Procedure</b>
Every 400 hours	<ul style="list-style-type: none"> <li>• Service the air cleaner. (Service the air cleaner earlier if the air-cleaner indicator shows red. Service it more frequently in extremely dirty or dusty conditions.)</li> <li>• Replace the fuel-filter canister.</li> <li>• Check the fuel lines and connections.</li> </ul>
Every 800 hours	<ul style="list-style-type: none"> <li>• Change the hydraulic fluid and filter.</li> <li>• Inspect the engine-valve clearance. Refer to your engine owner's manual.</li> </ul>
Every 1,500 hours	<ul style="list-style-type: none"> <li>• Replace any moving hoses.</li> </ul>
Every 2 years	<ul style="list-style-type: none"> <li>• Drain and clean the fuel tank.</li> <li>• Flush and replace the cooling-system fluid.</li> </ul>

***Important:* Refer to your engine owner's manual for additional maintenance procedures.**



# Daily Maintenance Checklist

Duplicate this page for routine use.

Maintenance Check Item	For the week of:						
	Monday	Tuesday	Wednesday	Thursday	Friday	Saturday	Sunday
Check the safety-interlock operation.							
Check the brake operation.							
Check the engine-oil level.							
Check the cooling-system-fluid level.							
Drain the water/fuel separator.							
Check the air filter, dust cup, and burp valve.							
Check for unusual engine noises. <sup>2</sup>							
Check the radiator and screen for debris							
Check for unusual operating noises.							
Check the hydraulic-system-oil level.							
Check the hydraulic hoses for damage.							
Check for fluid leaks.							
Check the fuel level.							
Check the tire pressure.							
Check the instrument operation.							
Check the height-of-cut adjustment.							
Lubricate all the grease fittings. <sup>2</sup>							
Touch up any damaged paint.							
Check the air-filter restriction indicator <sup>3</sup>							

<sup>1</sup>Check the glow plug and injector nozzles if starting is hard, there is excess smoke, or the engine is running rough.

<sup>2</sup>Immediately **after every** washing, regardless of the interval listed

<sup>3</sup>If the indicator shows red

## Notation for Areas of Concern

Inspection performed by:		
Item	Date	Information

## Pre-Maintenance Procedures

### ⚠ CAUTION

If you leave the key in the key switch, someone could accidentally start the engine and seriously injure you or other bystanders.

Remove the key from the key switch before you do any maintenance.

## Preparing the Machine for Maintenance

1. Ensure that the PTO is disengaged.
2. Park the machine on a level surface.
3. Engage the parking brake.
4. Lower the mower deck(s) and/or attachments if necessary.
5. Shut off the engine and wait for all moving parts to stop.
6. Turn the key to the STOP position and remove it.
7. Allow machine components to cool before performing maintenance.

## Using the Hood-Prop Rod

1. Release the hood latches.
2. Lift up the hood until you can position the prop rod behind the frame tube (Figure 27).
3. Lower the hood until the prop rod is in front of and resting against the frame tube.
4. To lower the hood, raise the hood until you can raise the prop rod above the frame tube, then lower the hood.
5. Secure the hood latches.

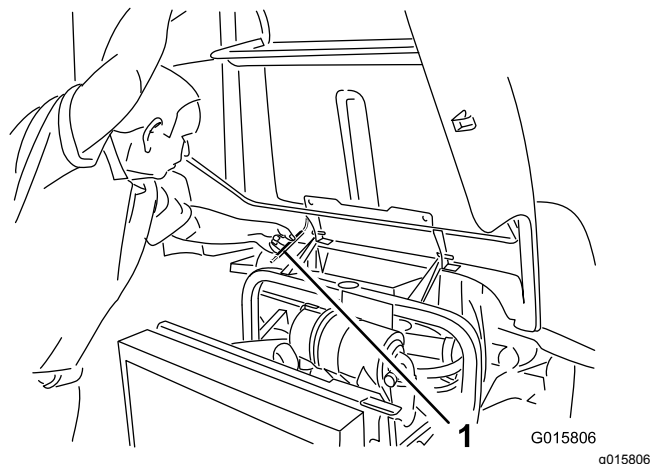

Figure 27

1. Prop rod

# Lubrication

## Greasing the Bearings and Bushings

**Service Interval:** Every 50 hours Grease the bearing and bushing grease fittings more frequently in extremely dusty and dirty conditions.

The machine has grease fittings that you must lubricate regularly with No. 2 lithium grease. Lubricate the grease fittings immediately after every washing, regardless of interval specified.

1. Wipe the grease fittings clean so that foreign matter cannot be forced into the bearing or bushing (Figure 29).
2. Pump the grease into the fittings.
3. Wipe off any excess grease.

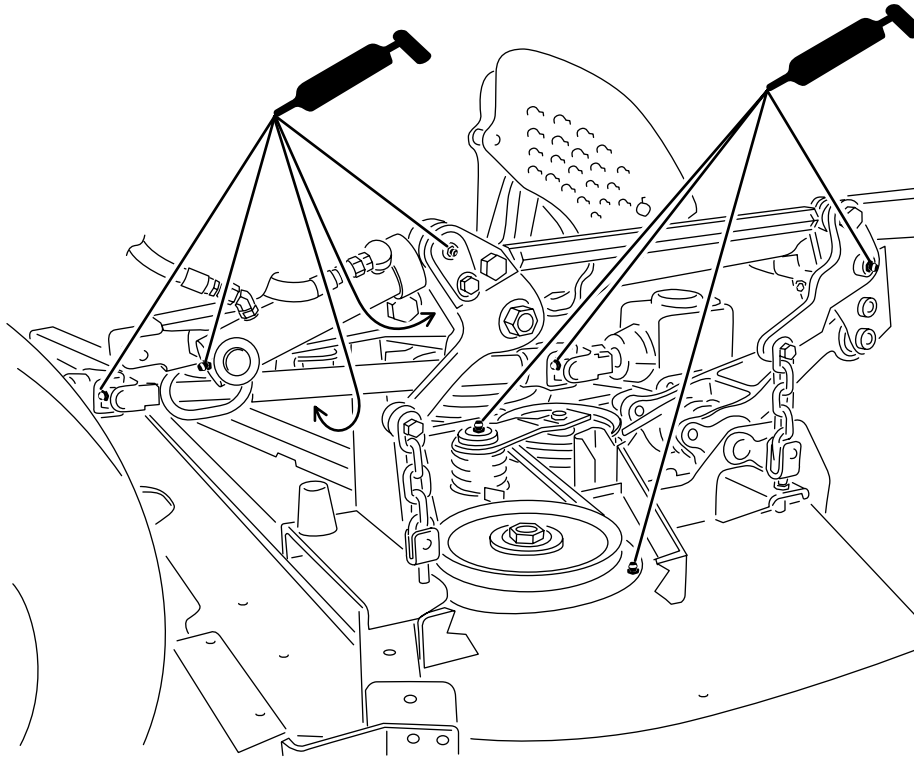

**Figure 28**

Shown with mower deck installed

g197547

**Note:** To access the grease fittings for the rear-steering linkage, remove the storage compartment.

**Note:** Raise the machine off the floor with a jack and secure it with jack stands to allow better grease

migration through both the upper and lower king-pin bushings. You should see grease purging out of both the top and the bottom of the axle casting/bushing assembly areas of all 4 kingpin assemblies (Figure 30).

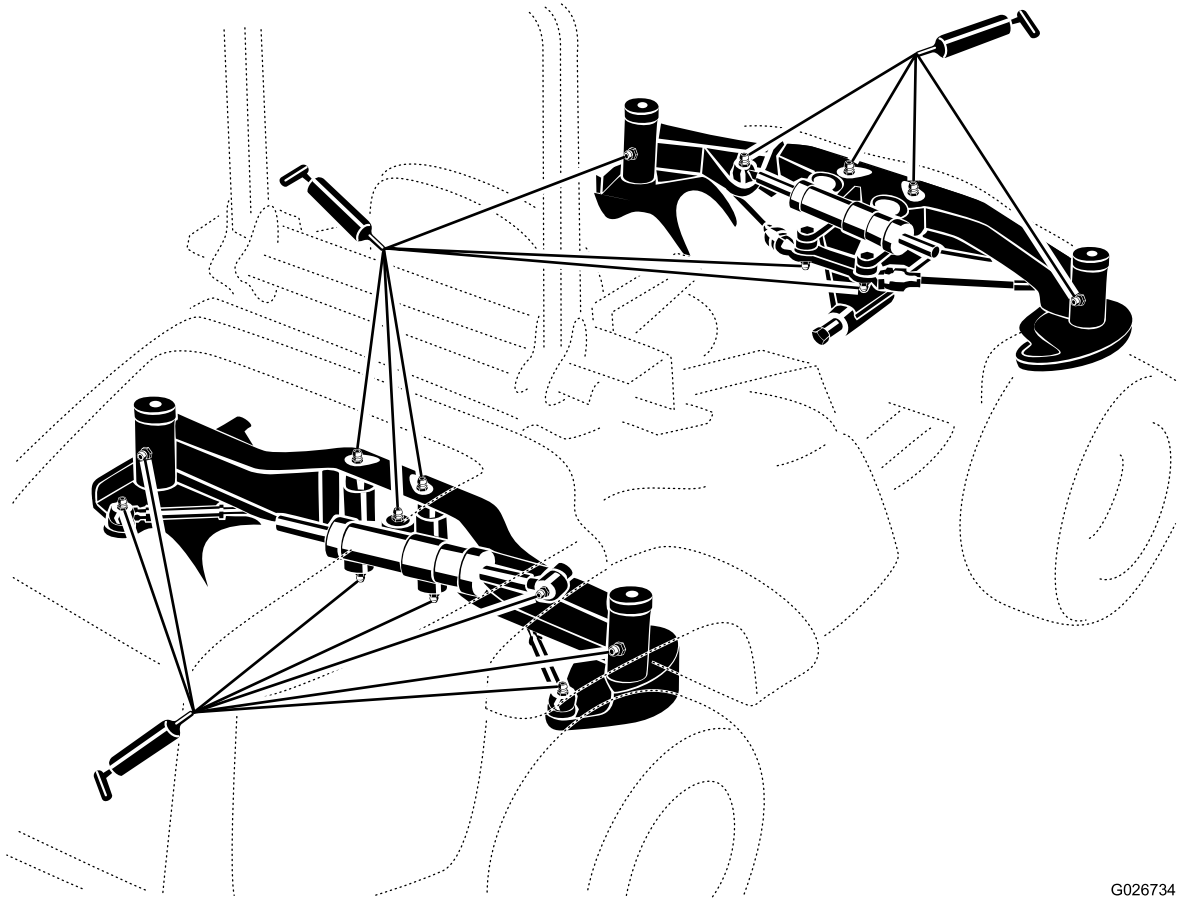

Figure 29

G026734

g026734

**Note:** The bearing life can be negatively affected by improper washing procedures. Do not wash the machine when it is still hot and avoid directing high-pressure or high-volume spray at the bearings or seals.

# Engine Maintenance

## Engine Safety

- Shut off the engine before checking the oil or adding oil to the crankcase.
- Do not change the governor speed or overspeed the engine.

## Servicing the Air Cleaner

**Service Interval:** Every 400 hours

Check the air-cleaner body for damage that could cause an air leak. Replace a damaged air cleaner. Check the whole intake system for leaks, damage, or loose hose clamps.

Service the air-cleaner filter only when the service indicator (Figure 30) requires it. Changing the air filter before it is necessary only increases the chance of dirt entering the engine when you remove the filter.

**Important:** Be sure that the cover is seated correctly and seals with the air-cleaner body.

1. Release the latch securing the air-cleaner cover to the air-cleaner body (Figure 30).

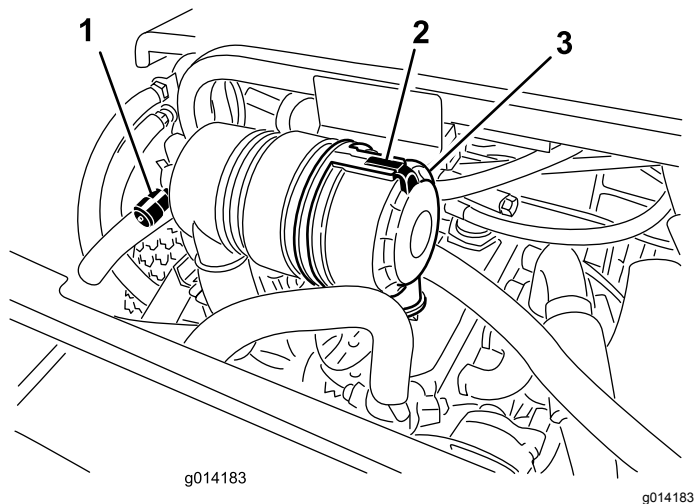

**Figure 30**

1. Air-cleaner-service indicator
2. Air-cleaner cover
3. Air-cleaner-cover latch

2. Remove the cover from the air-cleaner body. Before removing the filter, use clear and dry low-pressure air (276 kPa or 40 psi) to help remove large accumulations of debris packed between outside of the filter and the canister. **Avoid using high-pressure air, which could force dirt through the filter into the intake tract.**

**Note:** This cleaning process prevents debris from migrating into the intake when you remove the filter.

3. Remove and replace the filter.

**Important:** Do not clean the used element to prevent damaging the filter media. Inspect the new filter for shipping damage, checking the sealing end of the filter and the body. **Do not use a damaged element.** Insert the new filter by applying pressure to the outer rim of the element to seat it in the canister. **Do not apply pressure to the flexible center of the filter.**

4. Clean the dirt-ejection port located in the removable cover.
5. Remove the rubber outlet valve from the cover, clean the cavity and replace the outlet valve.
6. Install the cover orienting the rubber outlet valve in a downward position—approximately between the 5 o'clock to 7 o'clock positions when viewed from the end.
7. Secure the latch.

## Servicing the Engine Oil

### Oil Specification

Use high-quality, low-ash engine oil that meets or exceeds the following specifications:

- API service category CJ-4 or higher
- ACEA service category E6
- JASO service category DH-2

Use the following engine oil viscosity grade:

- Preferred oil: SAE 15W-40 (above 0°F)
- Alternate oil: SAE 10W-30 or 5W-30 (all temperatures)

Toro Premium Engine Oil is available from your authorized Toro distributor in either 15W-40 or 10W-30 viscosity grades. See the parts catalog for part numbers.

## Checking the Engine-Oil Level

**Service Interval:** Before each use or daily

The engine is shipped with oil in the crankcase; however, the oil level must be checked before and after the engine is first started.

**Important:** Check the engine oil daily. If the engine-oil level is above the Full mark on the dipstick, the engine oil may be diluted with fuel;

If the engine oil level is above the Full mark, change the engine oil.

The best time to check the engine oil is when the engine is cool before it has been started for the day. If it has already been run, allow the oil to drain back down to the sump for at least 10 minutes before checking. If the oil level is at or below the Add mark on the dipstick, add oil to bring the oil level to the Full mark. **Do not overfill the engine with oil.**

**Important:** Keep the engine oil level between the upper and lower limits on the dipstick; the engine may fail if you run it with too much or too little oil.

1. Perform the pre-maintenance procedure; refer to [Maintenance Safety \(page 31\)](#).
2. Open the hood.
3. Remove the dipstick, wipe it clean, and install it ([Figure 31](#)).

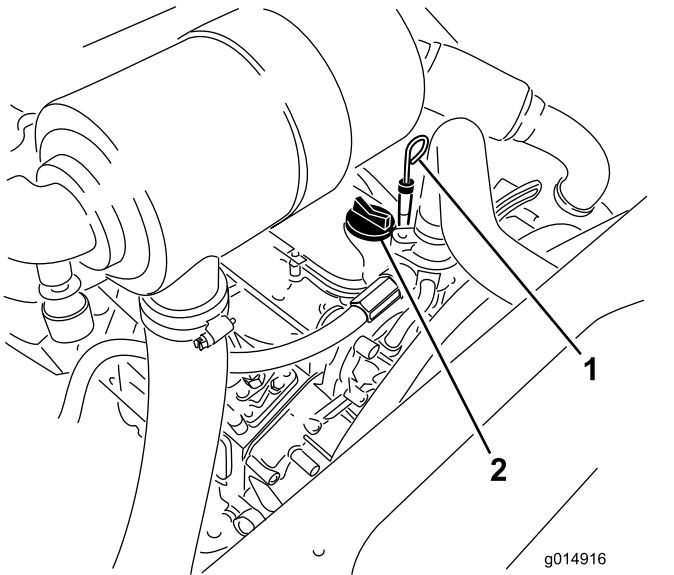

Figure 31

1. Dipstick
2. Oil-fill cap

4. Remove dipstick and check the oil level on dipstick. The oil level should be up to the FULL mark.
5. If the oil level is below the FULL mark, remove the fill cap ([Figure 31](#)) and add oil until level reaches the FULL mark on dipstick.
6. Install the oil fill cap and close the hood.

## Crankcase Oil Capacity

5.2 L (5.5 US qt) with the filter.

# Changing the Engine Oil and Filter

**Service Interval:** After the first 50 hours

Every 150 hours

1. Remove the drain plug ([Figure 32](#)) and let the oil flow into a drain pan.

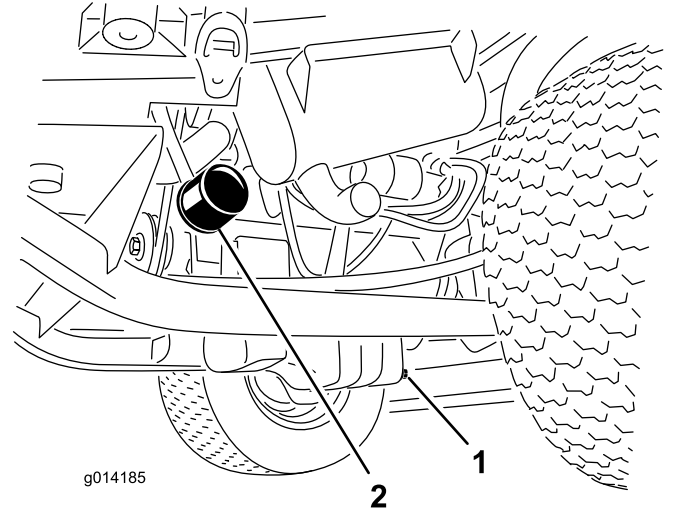

Figure 32

1. Oil-drain plug
2. Oil filter

2. When the oil stops, install the drain plug.
3. Remove the oil filter ([Figure 32](#)).
4. Apply a light coat of clean oil to the new filter seal.
5. Install the replacement oil filter to the filter adapter. Turn the oil filter clockwise until the rubber gasket contacts the filter adapter, then tighten the filter an additional 1/2 turn.

**Important:** Do not overtighten the filter.

6. Add oil to the crankcase; refer to [Checking the Engine-Oil Level \(page 37\)](#).

## Adjusting the Throttle

1. Move the throttle lever forward to the front of the control panel slot and then move it back approximately 3 mm (1/8 inch) into the FAST idle position.
2. Check the position of the speed control lever on the fuel-injection pump. The speed-control lever should contact the high-speed screw when the throttle-control lever is in the FAST (detent) position (Figure 33).

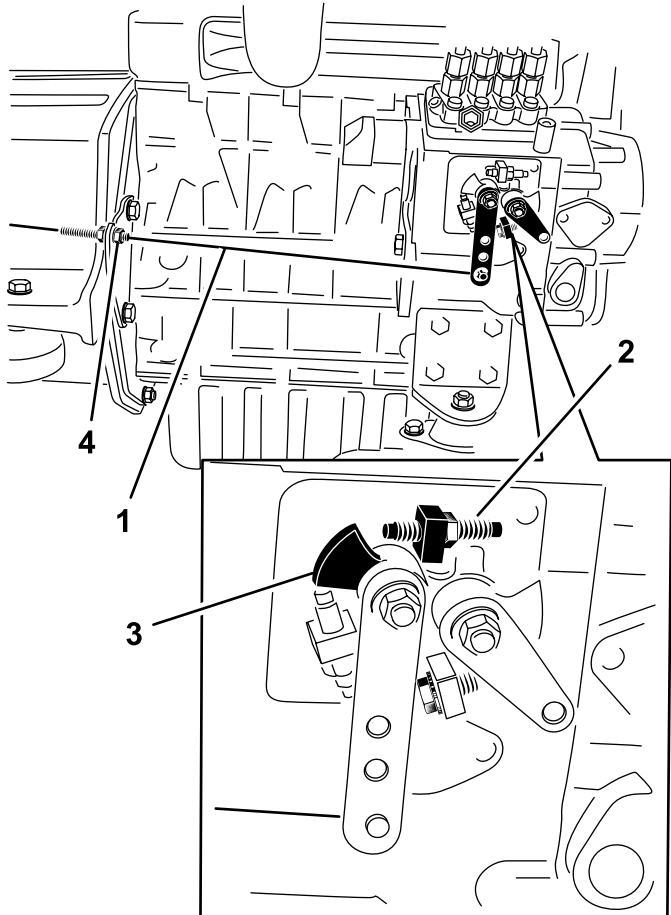

Figure 33

- |                     |                        |
|---------------------|------------------------|
| 1. Throttle cable   | 3. Speed-control lever |
| 2. High-speed screw | 4. Jam nuts            |

3. If necessary, adjust the position of the jam nuts on the throttle-control cable until the speed-control lever contacts the high-speed screw when the throttle-control lever is in the FAST (detent) position (Figure 33).
4. Ensure that the cable jam nuts are fully tightened after the adjustment.

## Fuel System Maintenance

**Note:** Refer to [Fuel Specification \(page 20\)](#) for the proper fuel recommendations.

### **⚠ DANGER**

Under certain conditions, diesel fuel and fuel vapors are highly flammable and explosive. A fire or explosion from fuel can burn you and others and can cause property damage.

- Use a funnel and fill the fuel tank outdoors, in an open area, when the engine is off and is cold. Wipe up any fuel that spills.
- Do not fill the fuel tank completely full. Add fuel to the fuel tank until the level is to the bottom of the filler neck.
- Never smoke when handling fuel and stay away from an open flame or where a spark may ignite fuel fumes.
- Store fuel in a clean, safety-approved container and keep the cap in place.

## Servicing the Water Separator

**Service Interval:** Before each use or daily

Every 400 hours

Service the water separator as shown in [Figure 34](#).

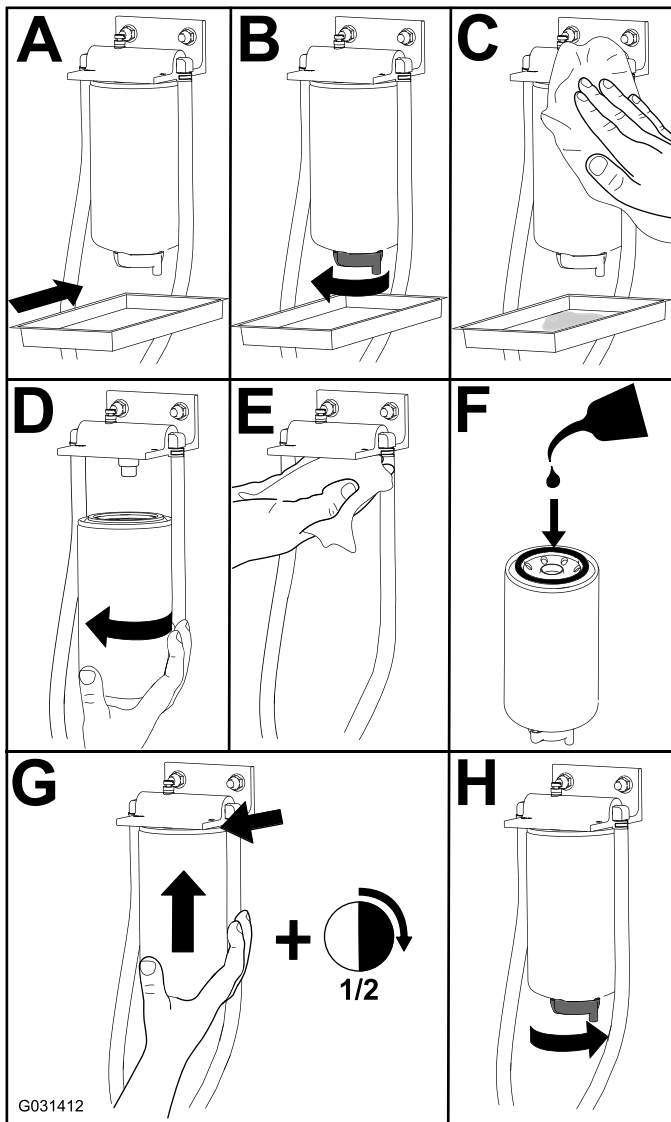

Figure 34

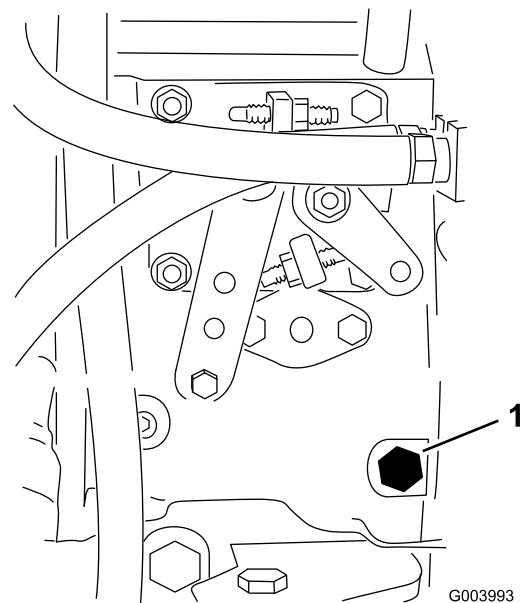

Figure 35

1. Bleed screw

4. Turn the key in the ignition switch to the ON position. The electric fuel pump will begin operation, thereby forcing air out around the air bleed screw. Leave the key in the ON position until a solid stream of fuel flows out around the screw.
5. Tighten the screw and turn the key to the OFF position.

**Note:** The engine should start after you perform this procedure. However, if engine does not start, air may be trapped between injection pump and the injectors; refer to [Bleeding Air from the Fuel Injectors \(page 40\)](#).

## Bleeding the Fuel System

You must bleed the fuel system before starting the engine if any of the following have occurred:

- Initial start up of a new machine
  - The engine has ceased running due to lack of fuel.
  - Maintenance has been performed upon fuel system components (i.e., filter replaced, separator serviced, etc.)
1. Perform the pre-maintenance procedure; refer to [Checking the Tire Pressure \(page 45\)](#) and ensure that the fuel tank is at least half full.
  2. Open the hood and secure it with the prop rod.
  3. Open the air-bleed screw on the fuel-injection pump ([Figure 35](#)) with a 12 mm wrench.

## Bleeding Air from the Fuel Injectors

**Note:** Use this procedure only if the fuel system has been purged of air through normal priming procedures and the engine does not start; refer to [Bleeding the Fuel System \(page 40\)](#).

1. Loosen the pipe connection to the No. 1 nozzle and holder assembly ([Figure 36](#)).



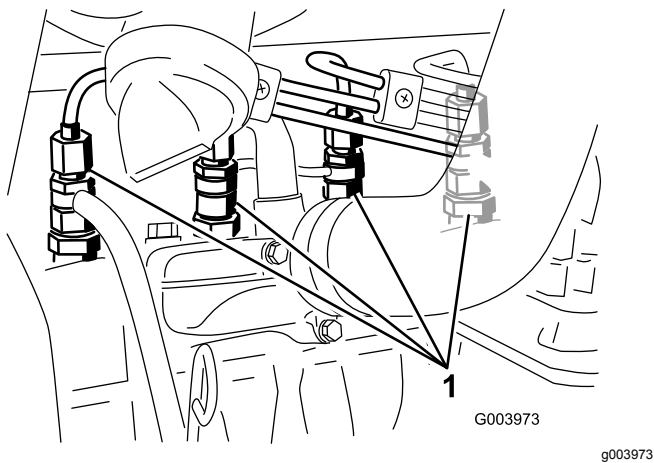

Figure 36

1. Fuel injectors

2. Turn the key in the key switch to the ON position and watch the fuel flow around the connector. When you observe a solid flow of fuel, turn the key to the OFF position.
3. Tighten the pipe connector securely.
4. Repeat steps 1 through 3 for the remaining nozzles.

## Cleaning the Fuel Tank

**Service Interval:** Every 2 years

Drain and clean the fuel tank every 2 years. Also, remove and clean the in-line strainers after draining the tank. Use clean diesel fuel to flush out the tank.

**Important:** Drain and clean the tank if the fuel system becomes contaminated or if you store the machine for an extended period of time.

## Checking the Fuel Lines and Connections

**Service Interval:** Every 400 hours

Inspect the fuel lines for deterioration, damage, chaffing, or loose connections.

# Electrical System Maintenance

## Electrical System Safety

- Disconnect the battery before repairing the machine. Disconnect the negative terminal first and the positive last. Connect the positive terminal first and the negative last.
- Charge the battery in an open, well-ventilated area, away from sparks and flames. Unplug the charger before connecting or disconnecting the battery. Wear protective clothing and use insulated tools.

## Servicing the Battery

**Service Interval:** Every 50 hours

Keep the top of the battery clean. If you store the machine in a location where temperatures are extremely high, the battery will run down more rapidly than if the machine is stored in a location where the temperature is cool.

Keep the top of the battery clean by washing it periodically with a brush dipped in ammonia or bicarbonate of soda solution. Flush the top surface with water after cleaning it. Do not remove the fill caps while cleaning the battery.

The battery cables must be tight on the terminals to provide good electrical contact.

If corrosion occurs at the terminals, disconnect the cables, negative (-) cable first, and scrape the clamps and terminals separately. Connect the cables, positive (+) cable first, and coat the terminals with petroleum jelly.

### **⚠ WARNING**

**Battery terminals or metal tools could short against metal machine components causing sparks. Sparks can cause the battery gasses to explode, resulting in personal injury.**

- **When removing or installing the battery, do not allow the battery terminals to touch any metal parts of the machine.**
- **Do not allow metal tools to short between the battery terminals and metal parts of the machine.**

## ⚠ WARNING

Incorrect battery cable routing could damage the machine and cables causing sparks. Sparks can cause the battery gasses to explode, resulting in personal injury.

- Always disconnect the negative (black) battery cable before disconnecting the positive (red) cable.
- Always connect the positive (red) battery cable before connecting the negative (black) cable.

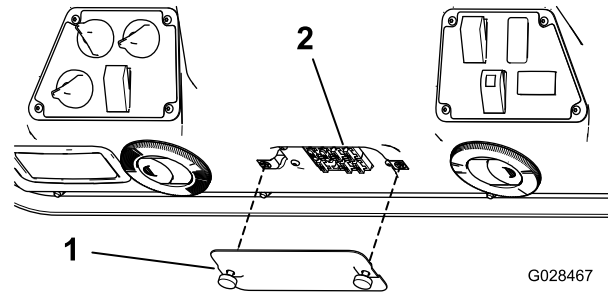

G028467

g028467

Figure 38

1. Cover
2. Fuses

## Checking the Fuses

If the machine stops or has other electrical-system issues, check the fuses. Grasp each fuse in turn and remove them 1 at a time, checking to see if any are blown. If you need to replace a fuse, always use the **same type and amperage rated fuse** as the 1 you are replacing; **otherwise, you could damage the electrical system** (refer to the decal next to the fuses for a diagram of each fuse and its amperage).

The traction-unit fuses are located under the seat (Figure 37).

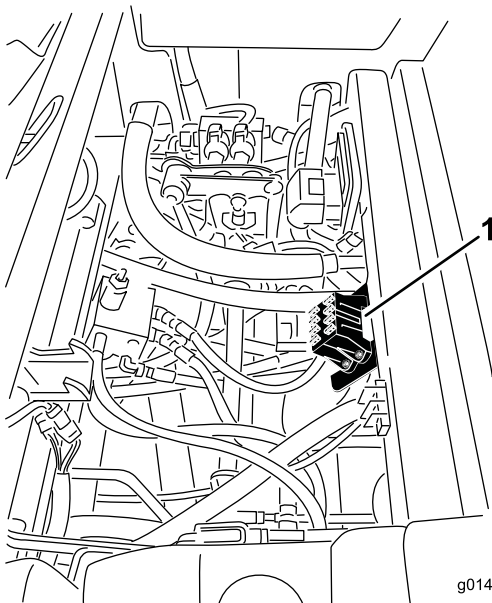

g014186

g014186

Figure 37

1. Location of the fuse block

The cab fuses are located in the fuse box on the cab headliner (Figure 38).

## Storing the Battery

If you store the machine for more than 30 days, remove the battery and charge it fully. Either store it on a shelf or on the machine. Leave the cables disconnected if you store it on the machine. Store the battery in a cool atmosphere to avoid quick deterioration of the charge in the battery. To prevent the battery from freezing, ensure that it is fully charged. The specific gravity of a fully charged battery is 1.265 to 1.299.

## Diagnostic Ace Display

The machine comes with an electronic controller which controls most of the machine functions. The controller determines what function is required for various input switches (e.g., seat switch and key switch) and turns on the outputs to actuate solenoids or relays for the requested machine function.

For the electronic controller to control the machine as desired, each of the input switches, output solenoids, and relays must be connected and functioning properly.

Use the Diagnostic ACE display tool and overlay to help verify and correct electrical functions of the machine. Contact your Toro Distributor for assistance.

## Checking the Interlock Switches

The interlock switches prevent the engine from cranking or starting unless the traction pedal is in the NEUTRAL position and the PTO is disengaged. The engine should stop when you press the traction pedal when you are not sitting on the seat or if the parking brake is engaged.

## ⚠ CAUTION

If safety interlock switches are disconnected or damaged, the machine could operate unexpectedly, causing personal injury.

- Do not tamper with the interlock switches.
- Check the operation of the interlock switches daily and replace any damaged switches before operating the machine.

## Verifying the Interlock Switch Function

1. Park the machine on a level surface, lower the attachment, shut off the engine, and engage the parking brake.
2. Raise the seat.
3. Locate the wire harness and connectors near the controller (Figure 39).

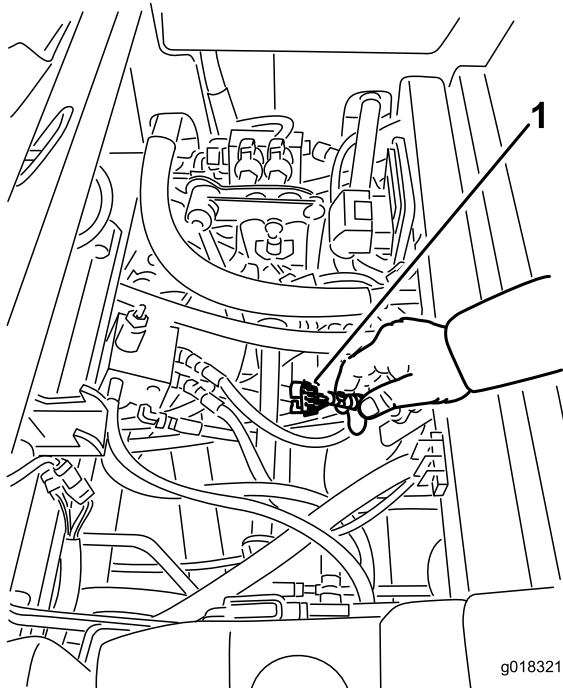
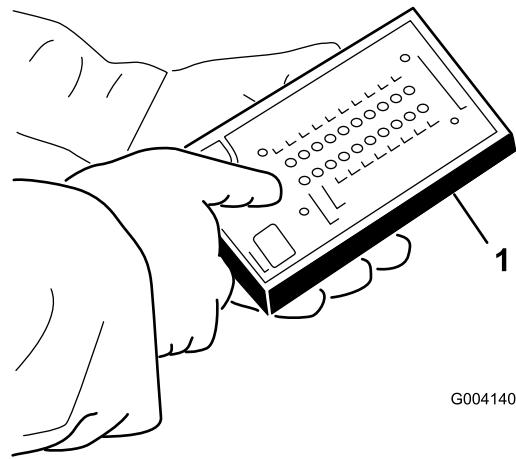

Figure 39

1. Wire harness and connectors

4. Connect the Diagnostic ACE display tool connector to the diagnostic connector (Figure 40).

**Note:** Ensure that the correct overlay decal is positioned on the Diagnostic ACE display.



G004140

g004140

Figure 40

1. Diagnostic ACE

5. Turn the key switch to the ON position, but do not start the engine.

**Note:** The red text on the overlay decal refers to input switches and the green text refers to outputs.

6. The “inputs displayed” LED, on the lower right column of the Diagnostic ACE, should be illuminated. If the “outputs displayed” LED is illuminated, press the toggle button on the Diagnostic ACE to change it to “inputs displayed.”

The Diagnostic ACE will illuminate the LED associated with each of the inputs when you close that input switch.

7. Individually change each of the switches from open to closed (i.e., sit on seat, engage the traction pedal, etc.), and note that the appropriate LED on Diagnostic ACE blinks on and off when you close the corresponding switch. Repeat this for all switches that you can change manually.
8. If a switch is closed and the appropriate LED does not turn on, check all wiring and connections to the switch and/or check the switch with an ohm meter. Replace all switches and repair wiring that are not functioning.

**Note:** The Diagnostic ACE also has the ability to detect which output solenoids or relays are turned on. This is a quick way to determine the source of the malfunction.

## Verifying the Output Function

1. Park the machine on a level surface, lower the attachment, shut off the engine, and engage the parking brake.
2. Raise the seat.
3. Locate wire harness and connectors near the controller.
4. Carefully unplug the loopback connector from the harness connector.
5. Connect the Diagnostic ACE connector to the appropriate harness connector. If the machine comes with a front attachment, it will have 2 controllers.

**Note:** Ensure that the correct overlay decal is positioned on the Diagnostic ACE.

6. Turn the key switch to the ON position, but do not start the engine.

**Note:** The red text on the overlay decal refers to input switches and the green text refers to outputs.

7. The “inputs displayed” LED, on the lower right column of the Diagnostic ACE, should be illuminated. If the “outputs displayed” LED is illuminated, press the toggle button on the Diagnostic ACE to change it to “inputs displayed.”

**Note:** You may need to toggle between “inputs displayed” and “outputs displayed” several times to do the following step. To toggle back and forth, press the toggle button once. Do this as often as necessary; do not hold the button.

8. Sit on the seat and attempt to operate the desired function of the machine. The appropriate output LEDs should illuminate to indicate that the ECM is turning on that function.

**Note:** If the correct output LEDs do not illuminate, verify that the required input switches are in the necessary positions to allow that function to occur. Verify the correct switch function.

If the output LEDs are on as specified but the machine does not function properly, this indicates a non-electrical problem; repair as needed.

**Note:** If each output switch is in the correct position and functioning correctly but the output LEDs are not correctly illuminated, this indicates an ECM problem. If this occurs, contact your Toro Distributor for assistance.

**Important:** Do not leave the Diagnostic ACE display connected to the machine. It is not designed to withstand the environment of the

everyday use of the machine. After using the Diagnostic ACE, disconnect it from the machine and connect the loop-back connector to the wire-harness connector. The machine cannot operate without the loopback connector installed on the wire harness. Store the Diagnostic ACE in dry, secure location in the shop, not on the machine.

# Drive System Maintenance

## Checking the Tire Pressure

**Service Interval:** Every 50 hours

Maintain the air pressure in the front and rear tires. The correct air pressure is 172 kPa (25 psi) in the rear tires and 103 kPa (15 psi) in the front tires. If a cab is installed on the machine, the front and rear tires should be inflated to 172 kPa (25 psi). Uneven tire pressure can cause an uneven cut. Check the tires when they are cold to get the most accurate pressure reading.

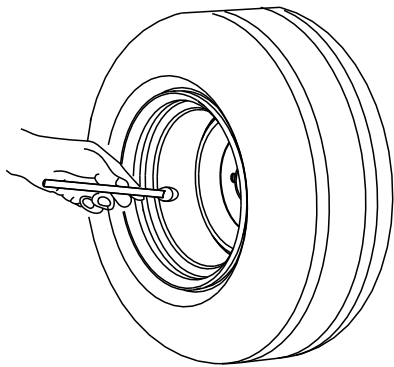

G001055

g001055

Figure 41

2. On a paved or dirt surface, turn the steering wheel to the left or right and continue turning until all 4 wheels have stopped turning. Automatic synchronization of the wheel alignment should occur.

**Important:** Doing this procedure on turf can result in turf damage directly under each of the turning tires.

## Correcting the Steering Misalignment

1. Press the steering-selector switch rearward 4-wheels steering position (Figure 42).

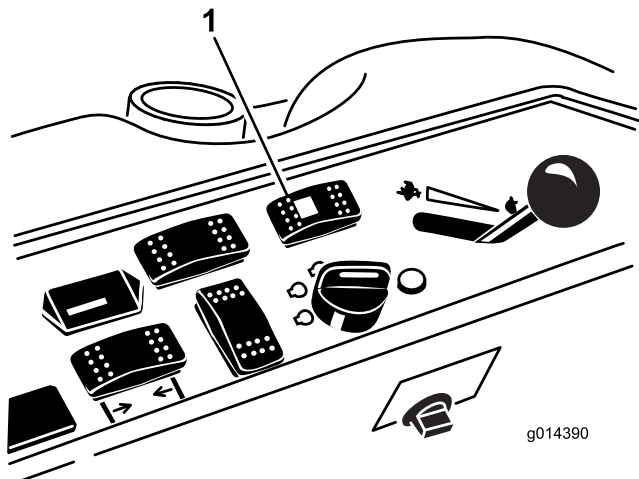

g014390

g014390

Figure 42

1. Steering-selector switch

# Cooling System Maintenance

## Cooling System Safety

- Swallowing engine coolant can cause poisoning; keep out of reach from children and pets.
- Discharge of hot, pressurized coolant or touching a hot radiator and surrounding parts can cause severe burns.
  - Always allow the engine to cool at least 15 minutes before removing the radiator cap.
  - Use a rag when opening the radiator cap, and open the cap slowly to allow steam to escape.
- Do not operate the machine without the covers in place.
- Keep your fingers, hands and clothing clear of rotating fan and drive belt.
- Shut off the engine and remove the key before performing maintenance.

## Checking the Cooling System

**Service Interval:** Before each use or daily

The cooling system is filled with a 50/50 solution of water and permanent ethylene glycol anti freeze. Check the level of the coolant in the expansion tank at the beginning of each day before starting the engine. The capacity of the cooling system is 7.5 L (6 US qt).

1. Check the level of the coolant in the expansion tank (Figure 43). The coolant level should be between the marks on the side of the tank.
2. If coolant level is low, remove the expansion tank cap and replenish the system. **Do not overfill.**

3. Install the expansion-tank cap.

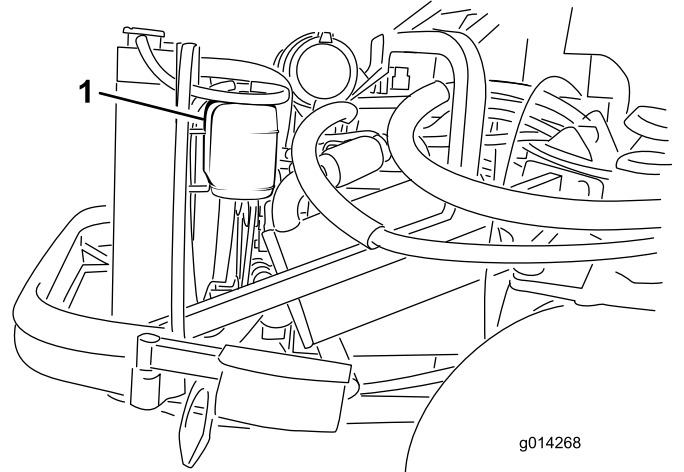

**Figure 43**

1. Expansion tank

## Cleaning the Radiator

**Service Interval:** Before each use or daily Clean the radiator more frequently in extremely dusty and dirty conditions.

Keep the radiator clean to prevent the engine from overheating.

**Note:** If the attachment or engine shuts off due to overheating, first check the radiator for an excessive buildup of debris.

1. Open the hood and secure the prop rod.
2. Loosen the flange nut securing the clean-out cover to the underside of the rear frame (Figure 44). Rotate the cover to the side to expose the clean-out hole in the frame.

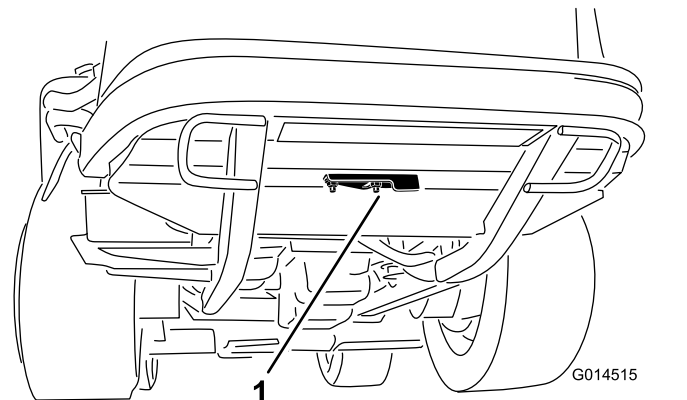

**Figure 44**

1. Clean-out cover

3. Working from the fan side of the radiator, blow out debris with low-pressure (50 psi) compressed air (**do not use water**). Repeat this

step from the front of the radiator, again from the fan side.

4. After you have thoroughly cleaned the radiator, remove any debris from the channel at the radiator base and around the frame.
5. Clean the engine compartment and the brake linkage.
6. Close the clean-out cover and secure the flange nut.
7. Close the hood.

## Brake Maintenance

### Adjusting the Brakes

Adjust the service brakes when there is more than 25 mm (1 inch) of free travel of the brake pedal, or when the brakes do not work effectively. Free travel is the distance that the brake pedal moves before you feel braking resistance.

**Note:** Use the wheel-motor backlash to rock the drums back and forth to ensure that the drums are free prior to and after adjustment.

1. To reduce free travel of the brake pedals, tighten the brakes by loosening the front nut on the threaded end of the brake cable ([Figure 45](#)).

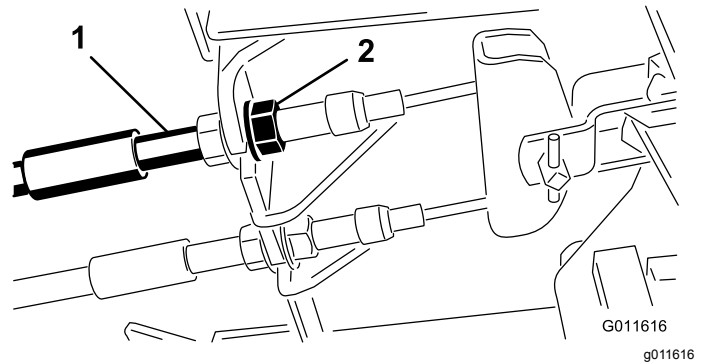

**Figure 45**

1. Brake cables
2. Front nuts

2. Tighten the rear nut to move the cable backward until brake pedals have 1.27 to 1.9 cm (1/2 to 3/4 inch) of free travel before the wheels lock up.
3. Tighten the front nuts, ensuring that both cables actuate the brakes simultaneously.

### Adjusting the Parking Brake

If the parking brake fails to engage, adjust the brake pawl.

1. Loosen the 2 screws securing the parking-brake pawl to the frame ([Figure 46](#)).

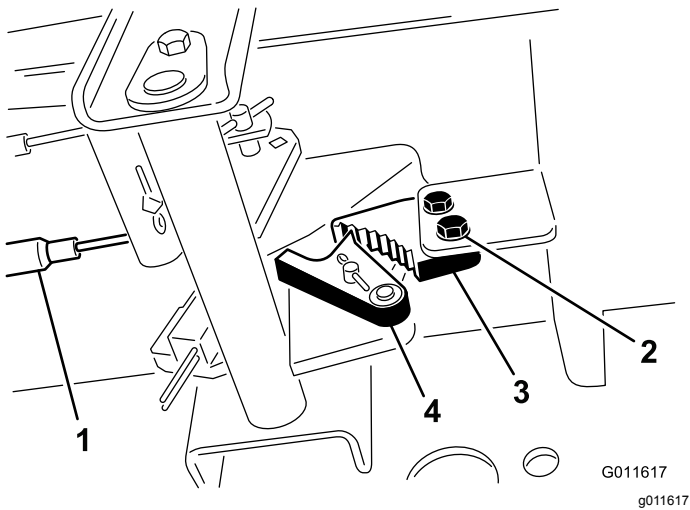

**Figure 46**

- |                 |                       |
|-----------------|-----------------------|
| 1. Brake cables | 3. Parking-brake pawl |
| 2. Screws (2)   | 4. Brake detent       |

2. Press the parking brake pedal forward until the brake detent completely engages on the brake pawl (Figure 46).
3. Tighten the 2 screws locking the adjustment.
4. Press the brake pedal to release the parking brake.
5. Check the adjustment and adjust it as required.

## Belt Maintenance

### Checking the Alternator Belt

**Service Interval:** Every 100 hours

After the first 10 hours

1. Open the hood and secure the prop rod.
2. Check the tension of the alternator belt by pressing it (Figure 47) midway between the alternator and the crankshaft pulleys with 10 kg (22 lb) of force.

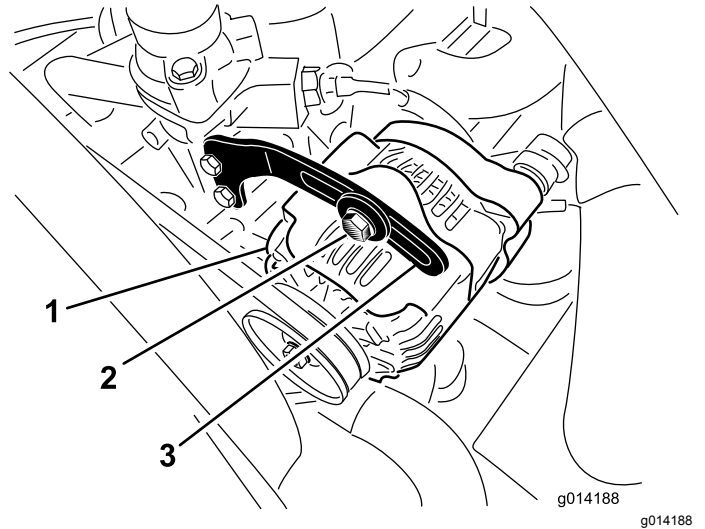

**Figure 47**

- |               |          |
|---------------|----------|
| 1. Alternator | 3. Brace |
| 2. Bolt       |          |

The belt should deflect 11 mm (7/16 inch). If the deflection is incorrect, proceed to step 3. If it is correct, you are finished with this procedure.

3. Loosen the bolt securing the brace to the alternator (Figure 47) and the alternator pivot bolt.
4. Insert a pry bar between the alternator and the engine and pry on the alternator.
5. When you achieve the proper tension, tighten the alternator, brace, and pivot bolts to secure the adjustment.



# Controls System Maintenance

## Adjusting the Traction Drive for Neutral

**Note:** If the machine has recently had the hydraulic fluid changed or the traction motors or hoses replaced, work out any air trapped in the system prior to performing this procedure. To do this, operate the machine in forward and reverse for a few minutes and then replenish the oil as required.

**Note:** When positioned on a level surface, the machine must not creep when you release the traction pedal.

1. Park the machine on a level surface, engage the parking brake, lower the cutting unit to the floor, and shut off the engine.
2. Jack up the rear of the machine until the rear tires are off the shop floor. Support the machine with jack stands to prevent it from falling.

**Note:** On 4-wheel-drive models, the front tires must also be off the shop floor and supported by jack stands.

### **⚠ WARNING**

**The engine must be running so that you can perform this adjustment. This could cause personal injury.**

**Keep your hands, feet, face, and other body parts away from any hot parts of the engine and any rotating parts.**

3. Start the engine, set the throttle to the SLOW position, and observe which direction the rear tires rotate.

**Important:** Make sure that the traction pedal is in the NEUTRAL position.

- If the left rear tire is rotating, loosen the jam nuts on the left side transmission control rod (Figure 48).

**Note:** The forward end of the control rod has a left-hand thread. The rear end of the rod, which is connected to the transmission, has a right-hand thread.

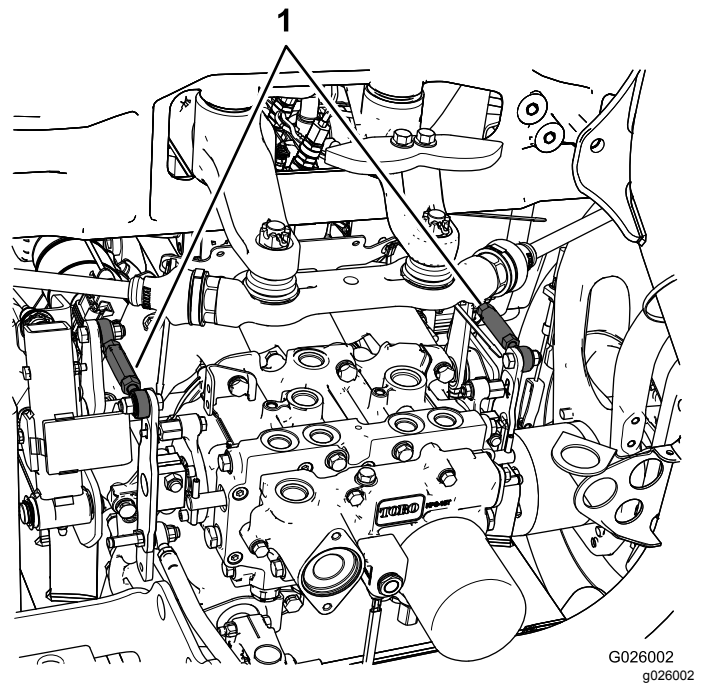

Figure 48

1. Transmission control rods

- If the left rear tire is rotating in reverse, lengthen the rod by slowly turning the rod counterclockwise (as viewed from the front) until the left rear tire stops rotating or has minimal rotation in reverse.
- If the left rear tire is rotating forward, shorten the rod by slowly turning the rod clockwise (as viewed from the front) until the left rear tire stops rotating.

4. Move the throttle to the FAST position. Make sure that the wheel remains stopped or has minimal rotation in reverse. Adjust it as required.
5. Tighten the jam nuts.
6. Repeat the procedure for the right rear tire, if required, by using the right-side transmission control rod.
7. Shut off the engine, remove the jack stands, and lower the machine to the shop floor.
8. Test drive the machine to make sure that it does not creep.

## Adjusting the Maximum Ground Speed

1. Park the machine on a level surface, disengage the PTO, release the traction pedal to the NEUTRAL position, and engage the parking brake.
2. Move the throttle lever to the SLOW position, shut off the engine, remove the key, and wait

for all moving parts to stop before leaving the operating position.

- Loosen the jam nut on the stop bolt for the traction pedal (Figure 49).

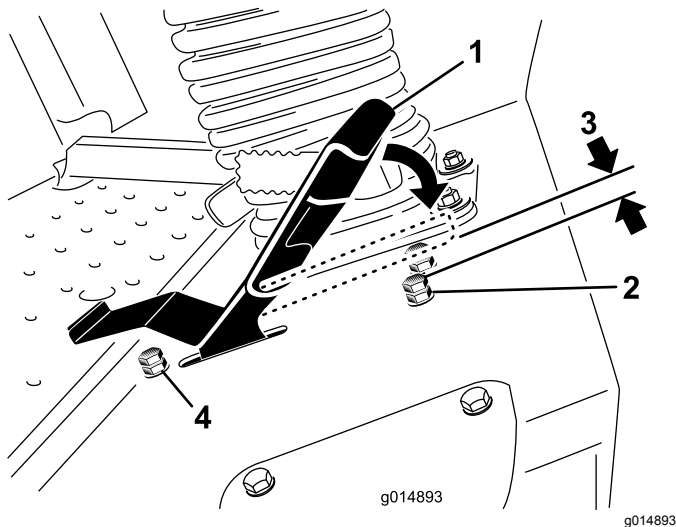

Figure 49

- |                                     |                                     |
|-------------------------------------|-------------------------------------|
| 1. Traction pedal                   | 3. 1.5 mm (0.060 inch)              |
| 2. Stop bolt with jam nut (forward) | 4. Stop bolt with jam nut (reverse) |

- Adjust the stop bolt all the way in (away from the traction pedal).
- Using your hand, push the traction pedal all the way forward, with light pressure, until it stops and hold it there.

**Note:** Maintain only light pressure on the pedal when pushing it to the full forward position.

- With the seat in the raised position, verify that you are not over loading the linkage by making sure the transmission does not move when you press the pedal to the stop.
- Adjust the stop bolt out (toward the traction pedal) until there is a gap of 1.5 mm (0.060 inch) between the head of the stop bolt and the bottom of the traction pedal.
- Tighten the jam nut to secure the stop bolt in place.
- To change the reverse speed, you can adjust the reverse stop bolt. To increase the reverse speed, adjust the stop bolt in; to decrease the reverse speed, adjust the stop bolt out.

## Hydraulic System Maintenance

### Hydraulic System Safety

- Seek immediate medical attention if fluid is injected into skin. Injected fluid must be surgically removed within a few hours by a doctor.
- Ensure that all hydraulic-fluid hoses and lines are in good condition and all hydraulic connections and fittings are tight before applying pressure to the hydraulic system.
- Keep your body and hands away from pinhole leaks or nozzles that eject high-pressure hydraulic fluid.
- Use cardboard or paper to find hydraulic leaks.
- Safely relieve all pressure in the hydraulic system before performing any work on the hydraulic system.

### Hydraulic Fluid Specification

The reservoir is filled at the factory with high-quality tractor transmission/hydraulic fluid. The recommended replacement fluid is as follows:

**Toro Premium Transmission/Hydraulic Tractor Fluid** (Available in 19 L (5 gallon) pails or 208 L (55 gallon) drums. See the *Parts Catalog* or your Toro Distributor for part numbers).

Alternate fluids: If the Toro fluid is not available, Mobil® 424 hydraulic fluid may be used.

**Note:** Toro will not assume responsibility for damage caused by improper substitutions.

Many hydraulic fluids are almost colorless, making it difficult to spot leaks. A red dye additive for the hydraulic system oil is available in 20 ml (2/3 fl oz) bottles. One bottle is sufficient for 15 to 22 L (4 to 6 US gallons) of hydraulic fluid. Order Part No. 44-2500 from your authorized Toro distributor.

### Checking the Hydraulic System

**Service Interval:** Before each use or daily

- Park the machine on a level surface, release the traction pedal to the NEUTRAL position, and start the engine.
- Run the engine at the lowest possible speed to purge the system of air.

**Important:** Do not engage the PTO.

3. Raise the deck to extend the lift cylinders, shut off the engine, and remove the key.
4. Remove the hydraulic-filler cap (Figure 50) from the filler neck.
5. Remove the dipstick and wipe it with a clean rag (Figure 50).
6. Screw the dipstick all the way into the filler neck; then remove it, and check the level of the fluid (Figure 50).

If the level is not within the notched area of the dipstick, add enough high-quality hydraulic fluid to raise the level to within the notched area. **Do not overfill the hydraulic system.**

7. Replace the dipstick and thread the fill cap finger-tight onto the filler neck.
8. Check all hoses and fittings for leaks.

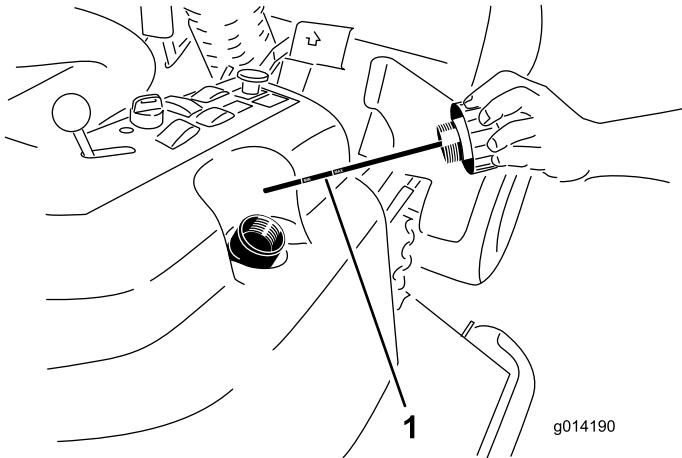

**Figure 50**

1. Dipstick

## Changing the Hydraulic Fluid And Filter

**Service Interval:** After the first 200 hours

Every 800 hours

**Hydraulic reservoir capacity:** approximately 17 L (18 US qt)

1. Disengage the PTO, release the traction pedal to the NEUTRAL position, and engage the parking brake.
2. Move the throttle lever to the SLOW position, shut off the engine, remove the key, and wait for all moving parts to stop before leaving the operating position.

3. Place a large pan under the hydraulic reservoir and transmission case and remove the plugs, draining all of the hydraulic fluid (Figure 51).

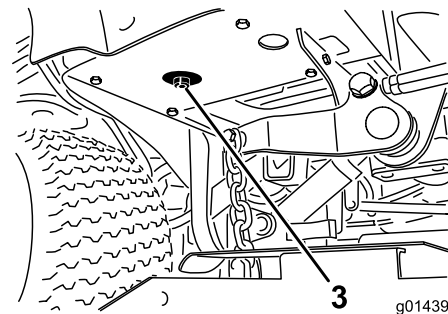
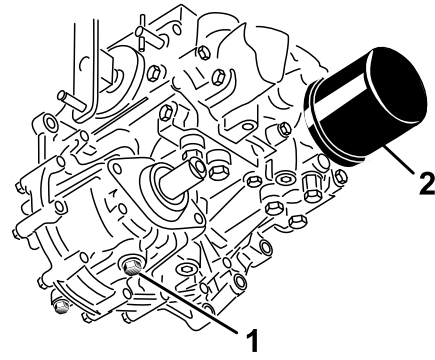

**Figure 51**

1. Transmission-case drain plug
2. Filter
3. Hydraulic-reservoir drain plug

4. Clean the area around the hydraulic-fluid filter and remove the filter (Figure 51).
5. Immediately install a new hydraulic-fluid filter.
6. Install the drain plugs in the hydraulic reservoir and the transmission case.
7. Fill the reservoir to the proper level; refer to [Checking the Hydraulic System \(page 50\)](#).
8. Start the engine and check for fluid leaks. Allow the engine to run for about 5 minutes, then shut it off.
9. After 2 minutes, check the level of the hydraulic fluid; refer to [Checking the Hydraulic System \(page 50\)](#).

# Cab Maintenance

## Cleaning the Cab

**Important:** Use care around the cab seals and lights (Figure 52). If you are using a pressure washer, keep the washer wand at least 0.6 m (2 ft) away from the machine. Do not use the pressure washer directly on the cab seals and lights or under the rear overhang.

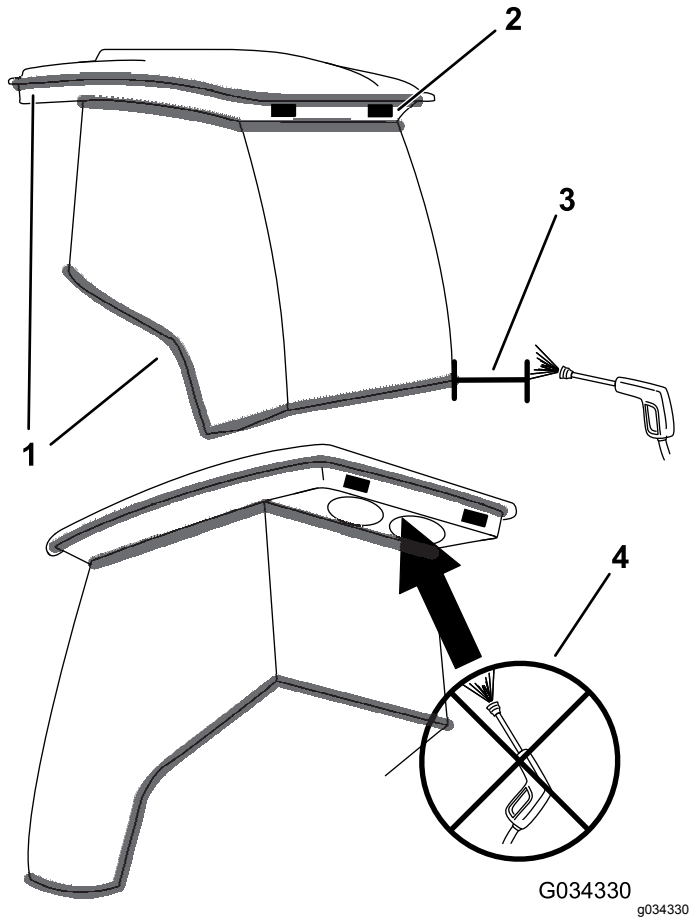

Figure 52

1. Seal
2. Light
3. Keep wand 0.6 m (2 ft) away.
4. Do not pressure-wash under the rear overhang.

## Filling the Washer-Fluid Bottle

1. Perform the pre-maintenance procedure; refer to [Preparing the Machine for Maintenance \(page 34\)](#).
2. Open the hood and locate the washer-fluid bottle (Figure 53).

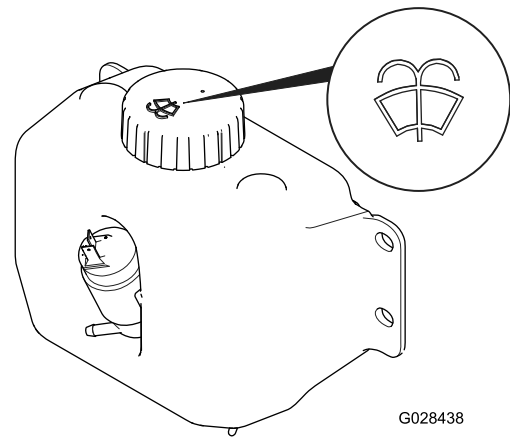

Figure 53

Washer-Fluid Bottle with Washer-Fluid Symbol

3. Fill the bottle with washer fluid as needed.
4. Close the hood.

## Cleaning the Cab Air Filters

**Service Interval:** Every 250 hours

1. Remove the screws and grates from both the in-cab and rear cab air filters (Figure 54 and Figure 55).

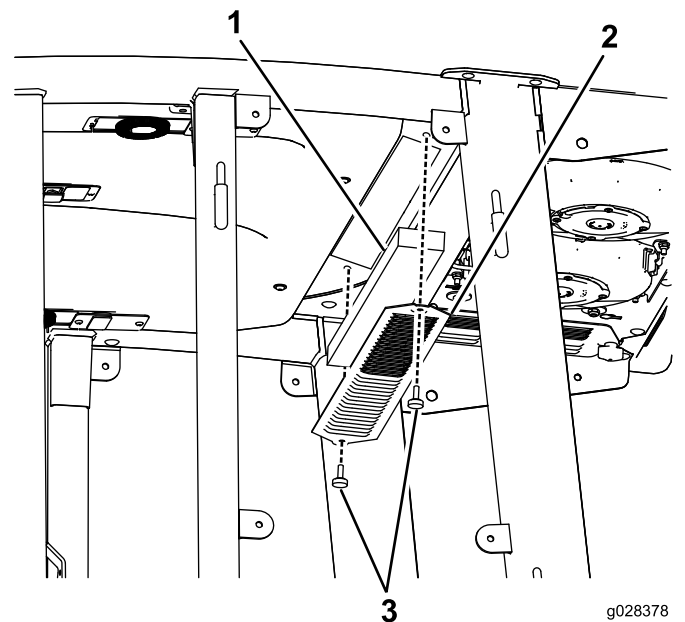
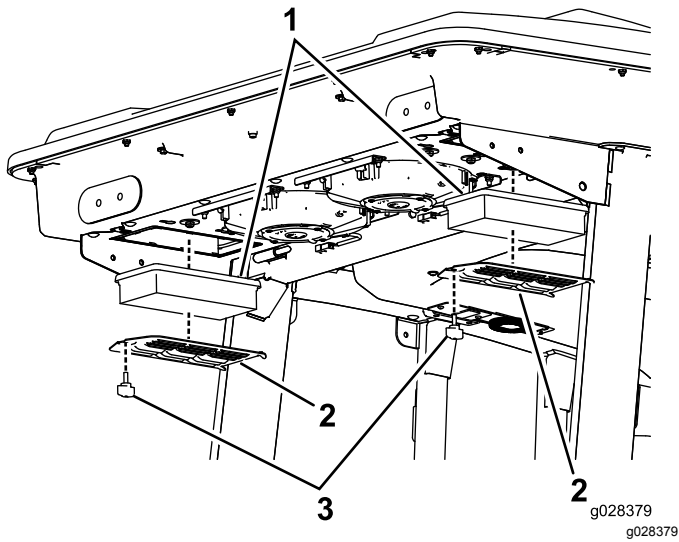

Figure 54

In-Cab Air Filter

1. Filter
2. Grate
3. Screw



**Figure 55**  
Rear Cab Air Filter

- 1. Filter
- 2. Grate
- 3. Screw

2. Clean the filters by blowing clean, oil-free, compressed air through them.

**Important:** If either filter has a hole, tear, or other damage, replace the filter.

3. Install the filters and the grate with the thumbscrews.

## Cleaning the Air-Conditioning Coil

**Service Interval:** Every 50 hours Clean the air-conditioning coil more frequently in extremely dusty or dirty conditions.

1. Perform the pre-maintenance procedure; refer to [Preparing the Machine for Maintenance \(page 34\)](#).
2. Lift the 4 tabs on the air-conditioning screen ([Figure 56](#)) and remove the screen from the top of the cab.

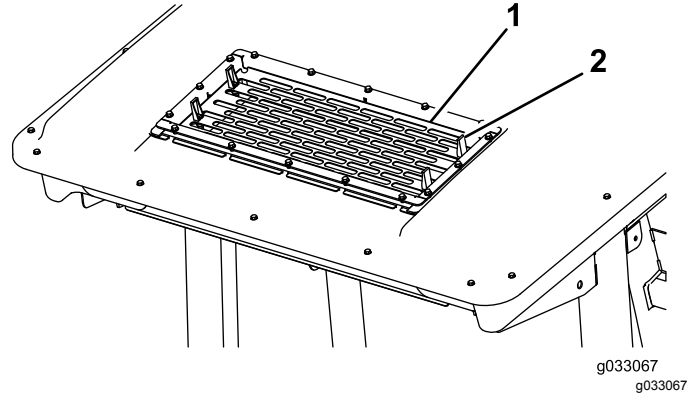

**Figure 56**

- 1. Screen
- 2. Tab (4)

3. Disconnect the plug and cord for the fans from the outlet ([Figure 57](#)).

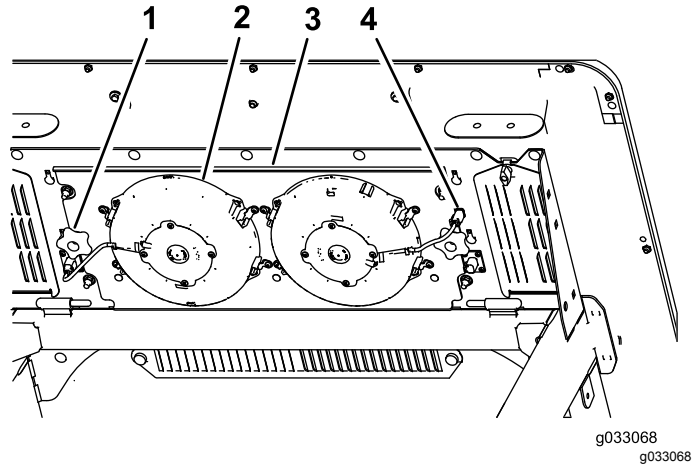

**Figure 57**

- 1. Knob (2)
- 2. Fan (2)
- 3. Fan panel
- 4. Plug and cord (2)

4. Remove the 2 knobs that secure the fan-panel assembly and fans to the underside of the cab top ([Figure 57](#)) and remove the assembly.

5. Clean the screen, air-conditioning duct, fans, and fan panel using low-pressure air no greater than 276 kPa (40 psi).

***Important:* Do not use water to clean the condenser because moisture on the components attracts dirt and dust, which make the components more difficult to clean.**

6. Install the fan-panel assembly and fans to the underside of the cab top with the 2 knobs that you loosened and removed in step 4.
7. Connect the cord for the fans that you disconnected in step 3 into the outlet.
8. Install the air-conditioning screen in the opening in the top of the cab and secure it by closing the 4 tabs on the screen.

## ***Cleaning***

## **Waste Disposal**

Engine oil, batteries, hydraulic fluid, and engine coolant are pollutants. Dispose of these according to your state and local regulations.

# Storage

## Preparing the Engine

1. Drain the engine oil from the oil pan and install the drain plug.
  2. Change the engine oil and filter; refer to [Checking the Engine-Oil Level \(page 37\)](#).
  3. Fill the engine with the designated quantity of engine oil; refer to [Checking the Engine-Oil Level \(page 37\)](#).
  4. Start the engine and run it at idle speed for 2 minutes.
  5. Drain the fuel from the fuel tank, fuel lines, pump, filter, and separator. Flush the fuel tank with clean diesel fuel and connect all fuel lines.
  6. Thoroughly clean and service the air-cleaner assembly.
  7. Seal the air-cleaner inlet and the exhaust outlet with weatherproof masking tape.
  8. Check the oil-filler cap and fuel-tank cap to ensure that they are securely in place.
- B. Clean the battery, terminals, and posts with a wire brush and baking-soda solution.
  - C. Coat the cable terminals and battery posts with Grafo 112X skin-over grease (Toro Part No. 505-47) or petroleum jelly to prevent corrosion.
  - D. Slowly charge the battery for 24 hours every 60 days to prevent lead sulfation of the battery.

## Preparing the Machine

1. Thoroughly clean the machine, the deck, and the engine, paying special attention to the following areas:
  - Radiator and radiator screen
  - Counterbalance springs
  - PTO-shaft assembly
  - All grease fittings and pivot points
  - Inside of the control box (Remove the control panel for access.)
  - Beneath the seat plate and the top of the transmission
2. Check and adjust the tire pressure; refer to [Checking the Tire Pressure \(page 45\)](#).
3. Check all fasteners for looseness and tighten them as necessary.
4. Grease or oil all grease fittings, pivot points, and transmission bypass-valve pins. Wipe off any excess lubricant.
5. Lightly sand and use touch-up paint on painted areas that are scratched, chipped, or rusted. Repair any dents in the metal body.
6. Service the battery and cables as follows:
  - A. Remove the battery terminals from the battery posts.

**Notes:**



**Notes:**

## EEA/UK Privacy Notice

### **Toro's Use of Your Personal Information**

The Toro Company ("Toro") respects your privacy. When you purchase our products, we may collect certain personal information about you, either directly from you or through your local Toro company or dealer. Toro uses this information to fulfil contractual obligations - such as to register your warranty, process your warranty claim or to contact you in the event of a product recall - and for legitimate business purposes - such as to gauge customer satisfaction, improve our products or provide you with product information which may be of interest. Toro may share your information with our subsidiaries, affiliates, dealers or other business partners in connection these activities. We may also disclose personal information when required by law or in connection with the sale, purchase or merger of a business. We will never sell your personal information to any other company for marketing purposes.

### **Retention of your Personal Information**

Toro will keep your personal information as long as it is relevant for the above purposes and in accordance with legal requirements. For more information about applicable retention periods please contact [legal@toro.com](mailto:legal@toro.com).

### **Toro's Commitment to Security**

Your personal information may be processed in the US or another country which may have less strict data protection laws than your country of residence. Whenever we transfer your information outside of your country of residence, we will take legally required steps to ensure that appropriate safeguards are in place to protect your information and to make sure it is treated securely.

### **Access and Correction**

You may have the right to correct or review your personal data, or object to or restrict the processing of your data. To do so, please contact us by email at [legal@toro.com](mailto:legal@toro.com). If you have concerns about the way in which Toro has handled your information, we encourage you to raise this directly with us. Please note that European residents have the right to complain to your Data Protection Authority.

# California Proposition 65 Warning Information

## What is this warning?

You may see a product for sale that has a warning label like the following:



**WARNING: Cancer and Reproductive Harm—**[www.p65Warnings.ca.gov](http://www.p65Warnings.ca.gov).

## What is Prop 65?

Prop 65 applies to any company operating in California, selling products in California, or manufacturing products that may be sold in or brought into California. It mandates that the Governor of California maintain and publish a list of chemicals known to cause cancer, birth defects, and/or other reproductive harm. The list, which is updated annually, includes hundreds of chemicals found in many everyday items. The purpose of Prop 65 is to inform the public about exposure to these chemicals.

Prop 65 does not ban the sale of products containing these chemicals but instead requires warnings on any product, product packaging, or literature with the product. Moreover, a Prop 65 warning does not mean that a product is in violation of any product safety standards or requirements. In fact, the California government has clarified that a Prop 65 warning "is not the same as a regulatory decision that a product is 'safe' or 'unsafe.'" Many of these chemicals have been used in everyday products for years without documented harm. For more information, go to <https://oag.ca.gov/prop65/faqs-view-all>.

A Prop 65 warning means that a company has either (1) evaluated the exposure and has concluded that it exceeds the "no significant risk level"; or (2) has chosen to provide a warning based on its understanding about the presence of a listed chemical without attempting to evaluate the exposure.

## Does this law apply everywhere?

Prop 65 warnings are required under California law only. These warnings are seen throughout California in a wide range of settings, including but not limited to restaurants, grocery stores, hotels, schools, and hospitals, and on a wide variety of products. Additionally, some online and mail order retailers provide Prop 65 warnings on their websites or in catalogs.

## How do the California warnings compare to federal limits?

Prop 65 standards are often more stringent than federal and international standards. There are various substances that require a Prop 65 warning at levels that are far lower than federal action limits. For example, the Prop 65 standard for warnings for lead is 0.5 µg/day, which is well below the federal and international standards.

## Why don't all similar products carry the warning?

- Products sold in California require Prop 65 labelling while similar products sold elsewhere do not.
- A company involved in a Prop 65 lawsuit reaching a settlement may be required to use Prop 65 warnings for its products, but other companies making similar products may have no such requirement.
- The enforcement of Prop 65 is inconsistent.
- Companies may elect not to provide warnings because they conclude that they are not required to do so under Prop 65; a lack of warnings for a product does not mean that the product is free of listed chemicals at similar levels.

## Why does Toro include this warning?

Toro has chosen to provide consumers with as much information as possible so that they can make informed decisions about the products they buy and use. Toro provides warnings in certain cases based on its knowledge of the presence of one or more listed chemicals without evaluating the level of exposure, as not all the listed chemicals provide exposure limit requirements. While the exposure from Toro products may be negligible or well within the "no significant risk" range, out of an abundance of caution, Toro has elected to provide the Prop 65 warnings. Moreover, if Toro does not provide these warnings, it could be sued by the State of California or by private parties seeking to enforce Prop 65 and subject to substantial penalties.



# The Toro Warranty

## A Two-Year Limited Warranty

### Conditions and Products Covered

The Toro Company and its affiliate, Toro Warranty Company, pursuant to an agreement between them, jointly warrant your Toro Commercial product ("Product") to be free from defects in materials or workmanship for two years or 1500 operational hours\*, whichever occurs first. This warranty is applicable to all products with the exception of Aerators (refer to separate warranty statements for these products). Where a warrantable condition exists, we will repair the Product at no cost to you including diagnostics, labor, parts, and transportation. This warranty begins on the date the Product is delivered to the original retail purchaser.

\* Product equipped with an hour meter.

### Instructions for Obtaining Warranty Service

You are responsible for notifying the Commercial Products Distributor or Authorized Commercial Products Dealer from whom you purchased the Product as soon as you believe a warrantable condition exists. If you need help locating a Commercial Products Distributor or Authorized Dealer, or if you have questions regarding your warranty rights or responsibilities, you may contact us at:

Toro Commercial Products Service Department  
Toro Warranty Company  
8111 Lyndale Avenue South  
Bloomington, MN 55420-1196  
952-888-8801 or 800-952-2740  
E-mail: commercial.warranty@toro.com

### Owner Responsibilities

As the Product owner, you are responsible for required maintenance and adjustments stated in your *Operator's Manual*. Failure to perform required maintenance and adjustments can be grounds for disallowing a warranty claim.

### Items and Conditions Not Covered

Not all product failures or malfunctions that occur during the warranty period are defects in materials or workmanship. This warranty does not cover the following:

- Product failures which result from the use of non-Toro replacement parts, or from installation and use of add-on, or modified non-Toro branded accessories and products. A separate warranty may be provided by the manufacturer of these items.
- Product failures which result from failure to perform recommended maintenance and/or adjustments. Failure to properly maintain your Toro product per the Recommended Maintenance listed in the *Operator's Manual* can result in claims for warranty being denied.
- Product failures which result from operating the Product in an abusive, negligent, or reckless manner.
- Parts subject to consumption through use unless found to be defective. Examples of parts which are consumed, or used up, during normal Product operation include, but are not limited to, brake pads and linings, clutch linings, blades, reels, rollers and bearings (sealed or greasable), bed knives, spark plugs, castor wheels and bearings, tires, filters, belts, and certain sprayer components such as diaphragms, nozzles, and check valves, etc.
- Failures caused by outside influence. Conditions considered to be outside influence include, but are not limited to, weather, storage practices, contamination, use of unapproved fuels, coolants, lubricants, additives, fertilizers, water, or chemicals, etc.
- Failure or performance issues due to the use of fuels (e.g. gasoline, diesel, or biodiesel) that do not conform to their respective industry standards.

### Countries Other than the United States or Canada

Customers who have purchased Toro products exported from the United States or Canada should contact their Toro Distributor (Dealer) to obtain guarantee policies for your country, province, or state. If for any reason you are dissatisfied with your Distributor's service or have difficulty obtaining guarantee information, contact the Toro importer.

- Normal noise, vibration, wear and tear, and deterioration.
- Normal "wear and tear" includes, but is not limited to, damage to seats due to wear or abrasion, worn painted surfaces, scratched decals or windows, etc.

### Parts

Parts scheduled for replacement as required maintenance are warranted for the period of time up to the scheduled replacement time for that part. Parts replaced under this warranty are covered for the duration of the original product warranty and become the property of Toro. Toro will make the final decision whether to repair any existing part or assembly or replace it. Toro may use remanufactured parts for warranty repairs.

### Deep Cycle and Lithium-Ion Battery Warranty:

Deep cycle and Lithium-Ion batteries have a specified total number of kilowatt-hours they can deliver during their lifetime. Operating, recharging, and maintenance techniques can extend or reduce total battery life. As the batteries in this product are consumed, the amount of useful work between charging intervals will slowly decrease until the battery is completely worn out. Replacement of worn out batteries, due to normal consumption, is the responsibility of the product owner. Battery replacement may be required during the normal product warranty period at owner's expense. Note: (Lithium-Ion battery only): A Lithium-Ion battery has a part only prorated warranty beginning year 3 through year 5 based on the time in service and kilowatt hours used. Refer to the *Operator's Manual* for additional information.

### Maintenance is at Owner's Expense

Engine tune-up, lubrication, cleaning and polishing, replacement of filters, coolant, and completing recommended maintenance are some of the normal services Toro products require that are at the owner's expense.

### General Conditions

Repair by an Authorized Toro Distributor or Dealer is your sole remedy under this warranty.

**Neither The Toro Company nor Toro Warranty Company is liable for indirect, incidental or consequential damages in connection with the use of the Toro Products covered by this warranty, including any cost or expense of providing substitute equipment or service during reasonable periods of malfunction or non-use pending completion of repairs under this warranty. Except for the Emissions warranty referenced below, if applicable, there is no other express warranty. All implied warranties of merchantability and fitness for use are limited to the duration of this express warranty.**

Some states do not allow exclusions of incidental or consequential damages, or limitations on how long an implied warranty lasts, so the above exclusions and limitations may not apply to you. This warranty gives you specific legal rights, and you may also have other rights which vary from state to state.

### Note regarding engine warranty:

The Emissions Control System on your Product may be covered by a separate warranty meeting requirements established by the U.S. Environmental Protection Agency (EPA) and/or the California Air Resources Board (CARB). The hour limitations set forth above do not apply to the Emissions Control System Warranty. Refer to the Engine Emission Control Warranty Statement supplied with your product or contained in the engine manufacturer's documentation for details.