



Count on it.

Operator's Manual

PowerPlex 40V Max Standard Battery Pack/Charger

Model No. 88540—Serial No. 319000001 and Up

Model No. 88541—Serial No. 319000001 and Up

Model No. 88542—Serial No. 319000001 and Up

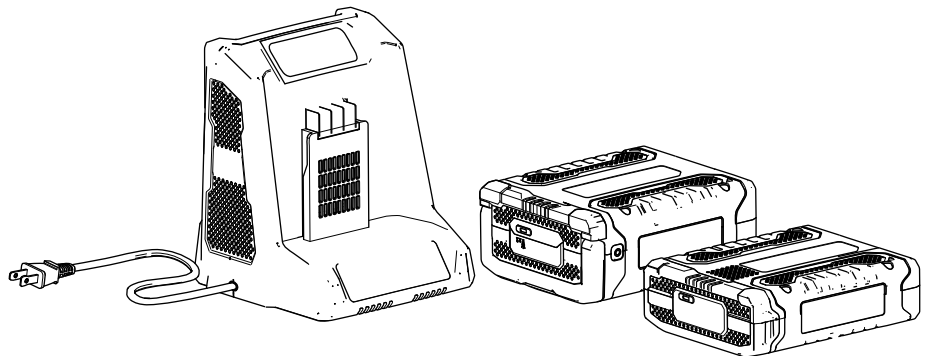

⚠ WARNING

**CALIFORNIA
Proposition 65 Warning**

The power cord on this product contains lead, a chemical known to the State of California to cause birth defects or other reproductive harm. Wash hands after handling.

Important: With your mobile device, you can scan the QR code (if equipped) on the serial number plate to access warranty, parts, and other product information.

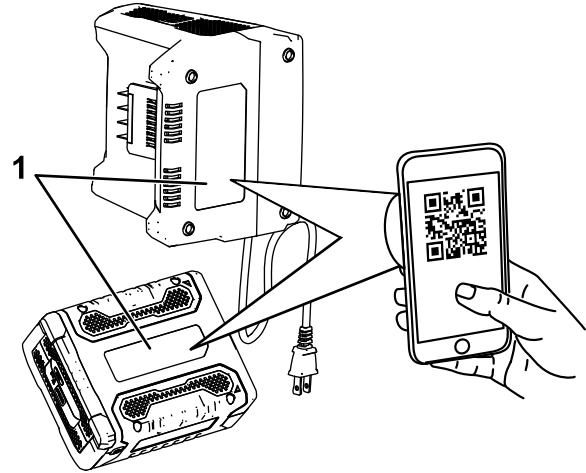

g262962

Figure 1

1. Model and serial number location

Introduction

This battery pack/charger is intended to be used by residential homeowners. Battery charger Model 88542 is designed primarily to charge battery pack Models 88540 and 88541. It is not designed to charge any other batteries.

Battery pack Models 88540 and 88541 are designed primarily for use in most Power Plex™ products.

Read this information carefully to learn how to operate and maintain your product properly and to avoid injury and product damage. You are responsible for operating the product properly and safely.

You may contact Toro directly at www.Toro.com for product and accessory information, help finding a dealer, complete warranty details, or to register your product.

Safety

IMPORTANT SAFETY INSTRUCTIONS—SAVE THESE INSTRUCTIONS.

SAVE THESE INSTRUCTIONS—This manual contains important safety and operating instructions for battery pack Models 88540/88541 and battery charger Model 88542.

Before using the battery charger, read all instructions and cautionary markings on the battery charger, battery pack, and product using the battery pack.

CAUTION—To reduce risk of injury, charge battery pack Models 88540 and 88541 with battery charger Model 88542 only. Other brands of battery packs may burst, causing personal injury and damage.

This device complies with Part 15 of the FCC rules. Operation is subject to the following 2 conditions: (1) this device may not cause harmful interference; and (2) this device must accept any interference received, including interference that may cause undesired operation.

Warning

- Use the battery charger indoors only.
- Do not recharge non-rechargeable batteries.
- Check prior use if the output voltage and current of the battery charger is suitable for charging the battery pack.
- Do not use the charger in the circumstances that the output polarity does not match the load polarity.
- If the supply cord is damaged, have the manufacturer or its service agent or a similar qualified person replace it in order to avoid a hazard.
- Do not open the cover may under any circumstances. If the cover is damaged, do not use the adaptor.
- Disconnect the supply before making or breaking the connections to the battery.
- This appliance can be used by persons with reduced physical, sensory, or mental capabilities or a lack of experience and knowledge if they are supervised or instructed concerning using the appliance safely and understand the hazards involved.
- Children shall not play with the appliance.
- Children shall not clean or maintain the appliance without supervision.

⚠ DANGER

Plugging the battery charger into an outlet that is not 120 V can cause fire or electric shock.

- Do not plug the battery charger into an outlet other than 120 V.
- For a foreign connection, use an attachment plug adapter of the proper configuration for the power outlet if needed.

⚠ CAUTION

The battery pack may present a risk of fire or chemical burn if mistreated.

- Do not disassemble the battery pack.
- Do not heat the battery pack above 70°C (158°F) or incinerate it.
- Replace the battery pack with a genuine Toro battery pack only; using another battery pack may cause a fire or explosion.
- Keep battery packs out of the reach of children and in the original packaging until they are ready to use.

⚠ CAUTION

Dispose of a used battery pack promptly.

Dispose of lithium-ion batteries at a recycling center designated for battery recycling.

⚠ CAUTION

Overheating a battery pack can cause fire and severe burns.

Do not open, crush, heat above 70°C (158°F), or incinerate. Follow the instructions for recycling the battery pack.

DANGER – TO REDUCE
THE RISK OF FIRE
OR ELECTRIC SHOCK,
CAREFULLY FOLLOW
THESE INSTRUCTIONS.

Safety and Instructional Decals



Safety decals and instructions are easily visible to the operator and are located near any area of potential danger. Replace any decal that is damaged or missing.

Symbol	Designation/Explanation
	Class II
	For indoor use only
	Before charging, read the instructions
	Current fuse
	Correct disposal of this product This marking indicates that this battery charger and battery pack should not be disposed with other household wastes throughout the EU. To prevent possible harm to the environment or human health from uncontrolled waste disposal, recycle it responsibly to promote the sustainable reuse of material resources. To return your used device, please use the return and collection systems or contact the retailer where the product was purchased. They can take this product for environmentally safe recycling.

TORO
LITHIUM-ION BATTERY CHARGER
CHARGEUR DE BATTERIE LITHIUM-ION
Input: 100-120V AC 50/60Hz Max 3.0A
Output: 41.8V MAX* DC 2.5A
*Battery manufacturer rating = 40V maximum & 36V nominal. Actual voltage varies with load.
*Tension indiquée par le fabricant de la batterie = 40 V max., 36 V nominale. La tension réelle varie en fonction de la charge.
Backfeed Protection / Protection contre le retour d'énergie
CAUTION To reduce the risk of injury, user must read the instruction manual. Charge only TORO PowerPlex type rechargeable battery. Other types of batteries may burst causing personal injury and damage. Risk of electric shock. Do not expose to liquid, vapor, or rain. Do not interconnect output terminal. For indoor use only.
ATTENTION Pour réduire le risque de blessures, l'utilisateur doit lire le manuel d'utilisation. Utiliser uniquement pour les batteries rechargeables type TORO PowerPlex. D'autres types de batteries pourraient exploser et causer des blessures ou des dommages. Risque de décharge électrique. Ne pas exposer à des liquides, à la vapeur ou à la pluie. Ne pas interconnecter la borne de sortie. Pour usage intérieur uniquement.
Country of Origin: PRC / Pays d'origine : PRC
THE TORO COMPANY 8111 Lyndale Avenue South Bloomington, MN 55420-1196 USA
PATENT: www.tcopats.com
Model: 88542 SL
Serial Number: [Redacted]
Date Code: [Redacted]

136-2473

decal136-2473

POWERPLEX™ 40V MAX LITHIUM
CHARGING PROCEDURE (LED INDICATOR) / PROCÉDURE DE CHARGEMENT (VOYANT DEL)
DO NOT REMOVE THIS DECAL / NE PAS RETIRER CET AUTOCOLLANT
1. [Battery icon with arrow] 2. [100% icon] 3. [Battery icon with exclamation mark] 4. [Lightning bolt icon]

136-2476

decal136-2476

1. The battery pack is charging.
2. The battery pack is fully charged.
3. The battery pack is too warm.
4. Replace the battery pack.

WARNING To reduce the risk of injury, user must read the instruction manual. Use only with TORO PowerPlex battery charger. Wear eye protection. Do not short terminals. Do not throw into fire. Risk of fire, explosion and burns. Do not disassemble, crush, expose to heat or incinerate. Keep battery out of reach of children. To reduce risk of injury to persons, remove battery pack when not in use.
AVERTISSEMENT Pour réduire le risque de blessures, l'utilisateur doit lire le manuel d'utilisation. Utilisez uniquement avec chargeur de batterie TORO PowerPlex. Portez des lunettes de protection. Ne pas court-circuiter. Ne jetez pas au feu. Risque d'incendie, d'explosion et des brûlures. Ne pas démonter, écraser, exposer à une température au-dessus ou en dessous de 40°C. Pour réduire les risques de blessures corporelles, retirez l'ensemble batterie quand la machine ne sert pas.
TORO 40V MAX* DC 90 Wh Li-Ion Battery / Batterie au lithium-ion
*Battery manufacturer rating = 40V maximum & 36V nominal. Actual voltage varies with load.
*Tension indiquée par le fabricant de la batterie = 40 V max., 36 V nominale. La tension réelle varie en fonction de la charge.
THE TORO COMPANY 8111 Lyndale Avenue South Bloomington, MN 55420-1196 USA
PATENT: www.tcopats.com
Model: 88540
Serial Number: [Redacted]
Date Code: [Redacted]

136-2471

Model 88540

decal136-2471

WARNING To reduce the risk of injury, user must read the instruction manual. Use only with TORO PowerPlex battery charger. Wear eye protection. Do not short terminals. Do not throw into fire. Risk of fire, explosion and burns. Do not disassemble, crush, expose to heat or incinerate. Keep battery out of reach of children. To reduce risk of injury to persons, remove battery pack when not in use.
AVERTISSEMENT Pour réduire le risque de blessures, l'utilisateur doit lire le manuel d'utilisation. Utilisez uniquement avec chargeur de batterie TORO PowerPlex. Portez des lunettes de protection. Ne pas court-circuiter. Ne jetez pas au feu. Risque d'incendie, d'explosion et des brûlures. Ne pas démonter, écraser, exposer à une température au-dessus ou en dessous de 40°C. Pour réduire les risques de blessures corporelles, retirez l'ensemble batterie quand la machine ne sert pas.
TORO 40V MAX* DC 180 Wh Li-Ion Battery / Batterie au lithium-ion
*Battery manufacturer rating = 40V maximum & 36V nominal. Actual voltage varies with load.
*Tension indiquée par le fabricant de la batterie = 40 V max., 36 V nominale. La tension réelle varie en fonction de la charge.
THE TORO COMPANY 8111 Lyndale Avenue South Bloomington, MN 55420-1196 USA
PATENT: www.tcopats.com
Model: 88541
Serial Number: [Redacted]
Date Code: [Redacted]

136-2472

Model 88541

decal136-2472

1. [Battery icon] 32°F ↔ 104°F
0°C ↔ 40°C

136-2539

decal136-2539

1. Charge the battery where the temperature is between 0°C and 40°C (32°F and 104°F).

Setup

Mounting the Battery Charger (Optional)

If desired, mount the battery charger securely on a wall using the wall-mount key holes on the back of the charger.

Mount it indoors (such as a garage or other dry place), near a power outlet, and out of the reach of children.

Refer to [Figure 2](#) for assistance in mounting the charger.

Note: Slide and twist the charger over the appropriately positioned hardware to secure the charger in place (hardware not included).

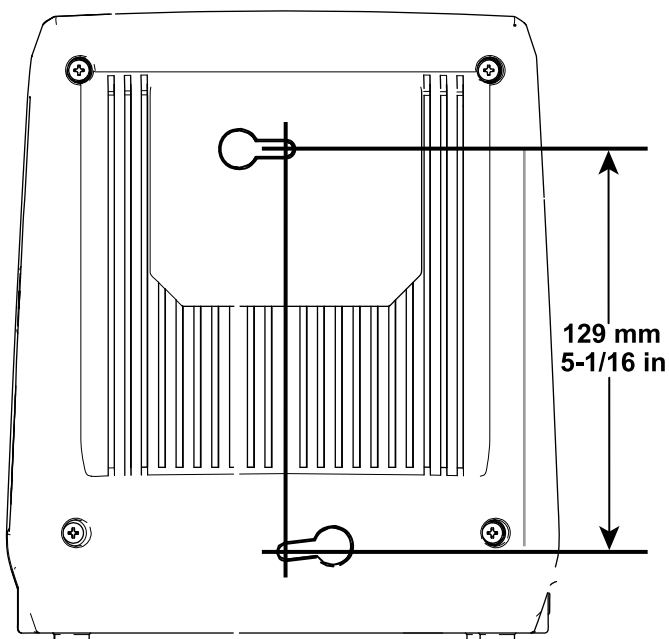

Figure 2

g194202

Product Overview

Specifications

Battery Charger

Model	88542
Type	40V MAX Lithium-Ion Battery Charger
Input	100 to 120V AC 50/60Hz Max 3.0A
Output	41.8V MAX DC 2.5A

Battery Pack

Model	88540	88541
Voltage per cell	3.6 V	3.6 V
Number of cells	10	20
Battery pack voltage	36 V	36 V
Battery pack capacity	2.5 Ah	5.0 Ah
Battery manufacturer rating = 40V maximum and 36V nominal. Actual voltage varies with load.		

Appropriate Temperature Ranges

Charge the battery at	0°C (32°F) to 40°C (104°F)*
Use products at	-15°C (5°F) to 60°C (140°F)
Store products at	-15°C (-5°F) to 60°C (140°F)
Unplug the charger if	Below 0°C (32°F) or above 40°C (104°F)

*Charging time will increase if you do not charge the battery within this range.

Store the tool, battery pack, and battery charger in an enclosed clean, dry area.

Operation

Charging the Battery Pack

Important: The battery pack is not fully charged when you purchase it. Before using the tool for the first time, place the battery pack in the charger and charge it until the LED display indicates the battery pack is fully charged. Read all safety precautions.

Important: Charge the battery pack only in temperatures that are within the appropriate range; refer to [Specifications \(page 6\)](#).

Note: At any time, press the battery-charge-indicator button on the battery pack to display the current charge (LED indicators).

1. Make sure that the vents on the battery are clear of any dust and debris.
2. Line up the cavity in the battery pack ([Figure 3](#)) with the tongue on the charger.

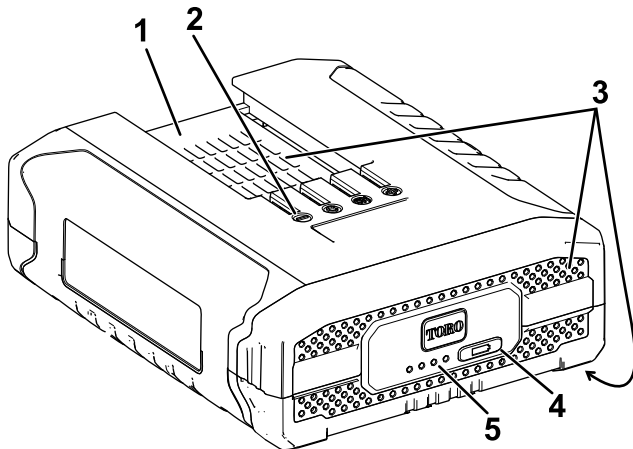

Figure 3
Model 88540

1. Battery pack cavity
2. Battery pack terminals
3. Battery pack venting areas
4. Battery-charge-indicator button
5. LED indicators (current charge)

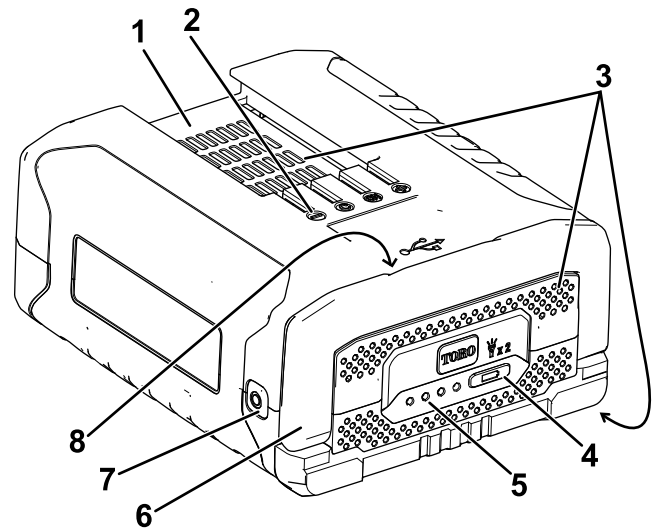

Figure 4
Model 88541

1. Battery pack cavity
2. Battery pack terminals
3. Battery pack venting areas
4. Battery-charge-indicator button
5. LED indicators (current charge)
6. Handle
7. Flashlight
8. USB port (not shown; located under handle)

Note: Quickly press the battery-charge-indicator button twice to turn the flashlight on or off (battery pack Model 88541 only). The flashlight automatically shuts off after approximately 60 minutes of use.

Note: The USB port is provided for your convenience to charge most small electronics, such as your cell phone or tablet (battery pack Model 88541 only).

3. Make sure that the vents on the battery charger are clear of any dust and debris.
4. Slide the battery pack into the charger until it is fully seated ([Figure 5](#)).

Installing the Battery Pack

Important: Operate the battery pack only in temperatures that are within the appropriate range; refer to [Specifications \(page 6\)](#).

1. Make sure that the vents on the battery are clear of any dust and debris.
2. Line up the cavity in the battery pack with the tongue on the tool.
3. Grasp the trigger handle.
4. Slide the battery pack into the tool until the battery locks into the latch ([Figure 6](#)).

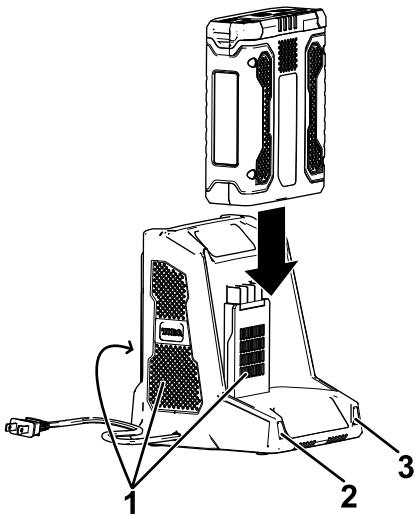

Figure 5

g194423

1. Charger venting areas
2. Left indicator light
3. Right indicator light

5. To remove the battery pack, slide the battery backward out of the charger.
6. Refer to the following table to interpret the LED indicators on the battery charger.

Left Light	Right Light	Indicates:
Off	Red	Charger is on; no battery pack inserted
Red	Red	Battery pack is charging
Green	Red	Battery pack is charged
Orange	Red	Battery pack is too warm
Red Blinking	Red	Replace the battery pack

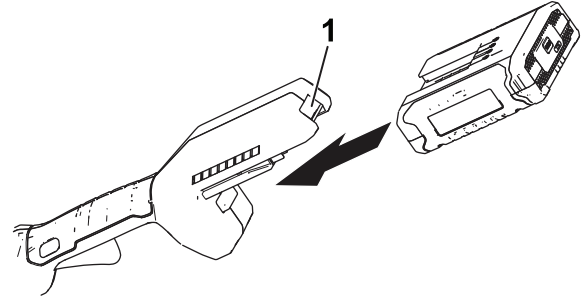

Figure 6
(Trimmer shown)

g189881

1. Battery latch

Removing the Battery Pack

Press the battery latch on the tool to release the battery pack and slide the battery pack out of the tool ([Figure 7](#)).

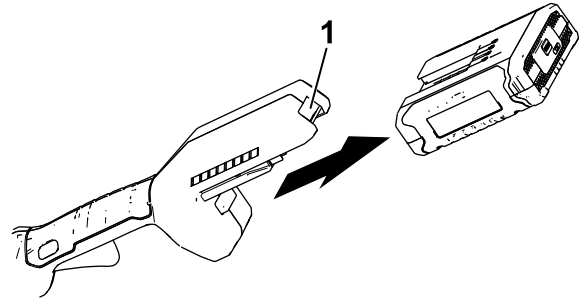

Figure 7
(Trimmer shown)

g192774

1. Battery latch

Maintenance

Maintenance and servicing are not required under normal conditions.

When you clean the surface of the equipment, wipe it only with a dry cloth.

Do not disassemble the equipment; if it is damaged, contact your Authorized Service Dealer.

Storage

Important: Store the tool, battery pack, and charger only in temperatures that are within the appropriate range; refer to [Specifications \(page 6\)](#).

Important: If you are storing the tool for a year or longer, remove the battery pack from the tool and charge the battery pack until 2 or 3 LED indicators turn blue on the battery. Do not store a fully charged or fully depleted battery. When you are ready to use the tool again, charge the battery pack until the left indicator light turns green on the charger or all 4 LED indicators turn blue on the battery.

- Disconnect the product from the power supply (i.e., remove the plug from the power supply or the battery pack) and check for damage after use.
- Clean all foreign material from the product.
- When not in use, store the tool, battery pack, and battery charger out of the reach of children.
- Keep the tool, battery pack, and battery charger away from corrosive agents, such as garden chemicals and de-icing salts.
- To reduce the risk of serious personal injury, do not store the battery pack outside or in vehicles.
- Store the tool, battery pack, and battery charger in an enclosed clean, dry area.

Preparing the Battery Pack for Recycling

Important: Upon removal, cover the terminals of the battery pack with heavy-duty adhesive tape. Do not attempt to destroy or disassemble the battery pack or remove any of its components. Recycle or properly dispose of lithium-ion battery packs at a battery recycling facility.



For more information on recycling lithium-ion battery packs and to locate the battery recycling facility closest to you, visit www.Call2Recycle.org (US and Canada only). If you are located outside of the US and Canada, please contact your authorized Toro distributor.

Troubleshooting

Perform only the steps described in these instructions. All further inspection, maintenance, and repair work must be performed by an authorized service center or a similarly qualified specialist if you cannot solve the problem yourself.

Problem	Possible Cause	Corrective Action
The flashlight does not turn on (battery pack Model 88541 only).	<ol style="list-style-type: none"> 1. The battery pack is on the charger. 2. The battery pack is over or under the appropriate temperature range. 3. The battery pack voltage is low. 	<ol style="list-style-type: none"> 1. Remove the battery pack from the charger. 2. Move the battery pack to a place where it is dry and the temperature is between 0°C (32°F) and 40°C (104°F). 3. Place the battery pack on the charger.
The USB port does not work (battery pack Model 88541 only).	<ol style="list-style-type: none"> 1. The battery pack is on the charger. 2. The battery pack is over or under the appropriate temperature range. 3. The battery pack voltage is low. 4. The USB port is not compatible with all small electronic devices. 	<ol style="list-style-type: none"> 1. Remove the battery pack from the charger. 2. Move the battery pack to a place where it is dry and the temperature is between 0°C (32°F) and 40°C (104°F). 3. Place the battery pack on the charger. 4. Use the USB port to charge a different small electronic device.
The battery pack loses charge quickly.	<ol style="list-style-type: none"> 1. The battery pack is over or under the appropriate temperature range. 	<ol style="list-style-type: none"> 1. Move the battery pack to a place where it is dry and the temperature is between 0°C (32°F) and 40°C (104°F).
The battery charger is not working.	<ol style="list-style-type: none"> 1. The battery charger is over or under the appropriate temperature range. 2. The outlet that the battery charger is plugged into does not have power. 	<ol style="list-style-type: none"> 1. Unplug the battery charger and move it to a place where it is dry and the temperature is between 0°C (32°F) and 40°C (104°F). 2. Contact your licensed electrician to repair the outlet.
The tool does not run or run continuously.	<ol style="list-style-type: none"> 1. There is moisture on the leads of the battery pack. 2. The battery is not fully installed into the tool. 	<ol style="list-style-type: none"> 1. Allow the battery pack to dry or wipe it dry. 2. Remove and then replace the battery into the tool making sure that it is fully installed and latched.
The battery pack shows only 3 LED indicators after only a few seconds of using a fully charged battery.	<ol style="list-style-type: none"> 1. This is a normal occurrence. 	<ol style="list-style-type: none"> 1. Stop the tool and press the battery-charge-indicator button or the remove the battery from the tool to display the actual battery charge.
All 4 LED indicators are blinking on the battery pack after you press the battery-charge-indicator button on the battery pack and the current charge displays (when the battery pack is not in use).	<ol style="list-style-type: none"> 1. The battery pack is over or under the appropriate temperature range. 	<ol style="list-style-type: none"> 1. Move the battery pack to a place where it is dry and the temperature is between 0°C (32°F) and 40°C (104°F).
All 4 LED indicators are blinking on the battery pack after releasing the trigger (when the battery pack is in use).	<ol style="list-style-type: none"> 1. The battery pack is over or under the appropriate temperature range. 	<ol style="list-style-type: none"> 1. Move the battery pack to a place where it is dry and the temperature is between 0°C (32°F) and 40°C (104°F).
2 LED indicators are blinking on the battery pack after you press the battery-charge-indicator button on the battery pack and the current charge displays (when the battery pack is not in use).	<ol style="list-style-type: none"> 1. There is a difference in voltage between cells in the battery pack. 	<ol style="list-style-type: none"> 1. Place the battery on the charger until it is fully charged.
2 LED indicators are blinking on the battery pack after releasing the trigger (when the battery pack is in use).	<ol style="list-style-type: none"> 1. There is a difference in voltage between cells in the battery pack. 	<ol style="list-style-type: none"> 1. Place the battery on the charger until it is fully charged.

Problem	Possible Cause	Corrective Action
1 LED indicator is blinking on the battery pack.	1. The battery pack voltage is low.	1. Place the battery pack on the charger.
It is difficult to remove the battery pack from the tool.	1. The battery pack/tool is new or there is corrosion in the battery terminals and/or the terminals on the tool.	1. Clean the terminals on the battery and the tool. Then apply dielectric grease to the battery terminals; do not use any other type of lubricant as it can damage the terminals.

California Proposition 65 Warning Information

What is this warning?

You may see a product for sale that has a warning label like the following:



WARNING: Cancer and Reproductive Harm—www.p65Warnings.ca.gov.

What is Prop 65?

Prop 65 applies to any company operating in California, selling products in California, or manufacturing products that may be sold in or brought into California. It mandates that the Governor of California maintain and publish a list of chemicals known to cause cancer, birth defects, and/or other reproductive harm. The list, which is updated annually, includes hundreds of chemicals found in many everyday items. The purpose of Prop 65 is to inform the public about exposure to these chemicals.

Prop 65 does not ban the sale of products containing these chemicals but instead requires warnings on any product, product packaging, or literature with the product. Moreover, a Prop 65 warning does not mean that a product is in violation of any product safety standards or requirements. In fact, the California government has clarified that a Prop 65 warning "is not the same as a regulatory decision that a product is 'safe' or 'unsafe.'" Many of these chemicals have been used in everyday products for years without documented harm. For more information, go to <https://oag.ca.gov/prop65/faqs-view-all>.

A Prop 65 warning means that a company has either (1) evaluated the exposure and has concluded that it exceeds the "no significant risk level"; or (2) has chosen to provide a warning based on its understanding about the presence of a listed chemical without attempting to evaluate the exposure.

Does this law apply everywhere?

Prop 65 warnings are required under California law only. These warnings are seen throughout California in a wide range of settings, including but not limited to restaurants, grocery stores, hotels, schools, and hospitals, and on a wide variety of products. Additionally, some online and mail order retailers provide Prop 65 warnings on their websites or in catalogs.

How do the California warnings compare to federal limits?

Prop 65 standards are often more stringent than federal and international standards. There are various substances that require a Prop 65 warning at levels that are far lower than federal action limits. For example, the Prop 65 standard for warnings for lead is 0.5 µg/day, which is well below the federal and international standards.

Why don't all similar products carry the warning?

- Products sold in California require Prop 65 labelling while similar products sold elsewhere do not.
- A company involved in a Prop 65 lawsuit reaching a settlement may be required to use Prop 65 warnings for its products, but other companies making similar products may have no such requirement.
- The enforcement of Prop 65 is inconsistent.
- Companies may elect not to provide warnings because they conclude that they are not required to do so under Prop 65; a lack of warnings for a product does not mean that the product is free of listed chemicals at similar levels.

Why does Toro include this warning?

Toro has chosen to provide consumers with as much information as possible so that they can make informed decisions about the products they buy and use. Toro provides warnings in certain cases based on its knowledge of the presence of one or more listed chemicals without evaluating the level of exposure, as not all the listed chemicals provide exposure limit requirements. While the exposure from Toro products may be negligible or well within the "no significant risk" range, out of an abundance of caution, Toro has elected to provide the Prop 65 warnings. Moreover, if Toro does not provide these warnings, it could be sued by the State of California or by private parties seeking to enforce Prop 65 and subject to substantial penalties.