



**Count on it.**

Form No. 3421-177 Rev C

**Operator's Manual**

# MB TX 2500 Tracked Mud Buggy

Model No. 68138—Serial No. 402100000 and Up

Model No. 68138G—Serial No. 402100000 and Up

Model No. 68138HD—Serial No. 400000000 and Up

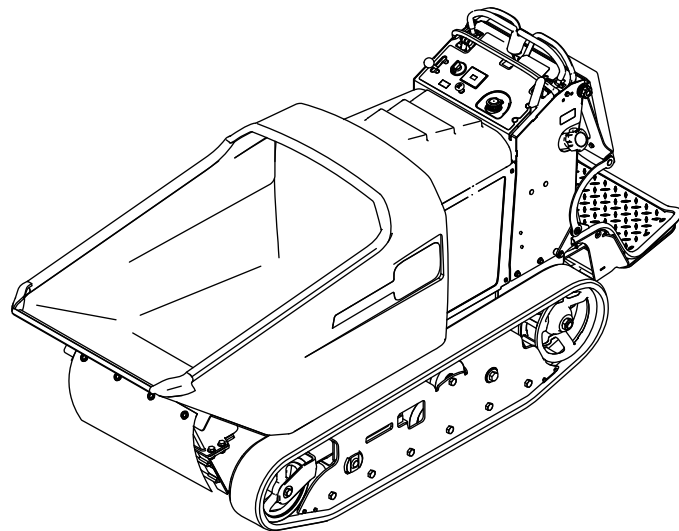

It is a violation of California Public Resource Code Section 4442 or 4443 to use or operate the engine on any forest-covered, brush-covered, or grass-covered land unless the engine is equipped with a spark arrester, as defined in Section 4442, maintained in effective working order or the engine is constructed, equipped, and maintained for the prevention of fire.

Because in some areas there are local, state, or federal regulations requiring that a spark arrester be used on the engine of this machine, a spark arrester is available as an option. If you require a spark arrester, contact your Authorized Service Dealer. Genuine Toro spark arresters are approved by the USDA Forestry Service.

The enclosed engine owner's manual is supplied for information regarding the US Environmental Protection Agency (EPA) and the California Emission Control Regulation of emission systems, maintenance, and warranty. Replacements may be ordered through the engine manufacturer.

## ⚠ WARNING

### CALIFORNIA Proposition 65 Warning

The engine exhaust from this product contains chemicals known to the State of California to cause cancer, birth defects, or other reproductive harm.

Battery posts, terminals, and related accessories contain lead and lead compounds, chemicals known to the State of California to cause cancer and reproductive harm. Wash hands after handling.

Use of this product may cause exposure to chemicals known to the State of California to cause cancer, birth defects, or other reproductive harm.

# Introduction

This machine is intended to be used by professional, hired operators in commercial applications. This machine is a stable, reliable, and productive machine for carrying and moving materials for any job site. It is primarily designed to move concrete, mortar, gravel, dirt, or debris around job sites.

Read this information carefully to learn how to operate and maintain your product properly and to avoid injury and product damage. You are responsible for operating the product properly and safely.

You may contact Toro directly at [www.Toro.com](http://www.Toro.com) for product safety and operation training materials, accessory information, help finding a dealer, or to register your product.

Whenever you need service, genuine Toro parts, or additional information, contact an Authorized Service Dealer or Toro Customer Service and have the model and serial numbers of your product ready. **Figure 1** identifies the location of the model and serial numbers on the product. Write the numbers in the space provided.

**Important:** With your mobile device, you can scan the QR code on the serial number decal (if equipped) to access warranty, parts, and other product information.

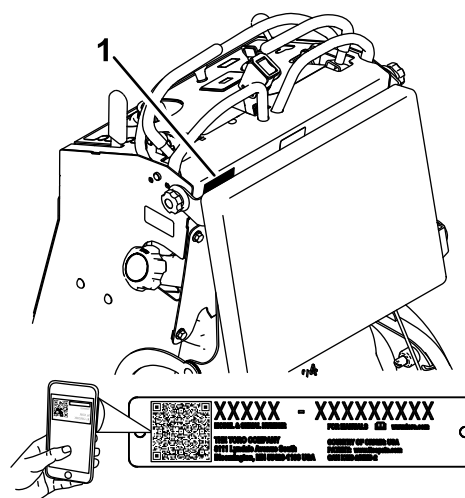

**Figure 1**

1. Model and serial number location

Model No.	_____
Serial No.	_____

This manual identifies potential hazards and has safety messages identified by the safety-alert symbol (**Figure 2**), which signals a hazard that may cause

serious injury or death if you do not follow the recommended precautions.



Figure 2

g000502

- 1. Safety-alert symbol

This manual uses 2 words to highlight information. **Important** calls attention to special mechanical information and **Note** emphasizes general information worthy of special attention.

# Contents

- Safety ..... 4
  - Safe Operating Practices ..... 4
  - Safety and Instructional Decals ..... 6
- Product Overview ..... 9
  - Controls ..... 9
  - Specifications ..... 10
  - Attachments/Accessories ..... 10
- Operation ..... 10
  - Adding Fuel ..... 10
  - Performing Daily Maintenance ..... 12
  - Operating the Parking Brake ..... 12
  - Operating the Throttle ..... 13
  - Operating the Choke ..... 13
  - Starting the Engine ..... 13
  - Shutting Off the Engine ..... 14
  - Operating the Hopper ..... 14
  - Removing Debris from the Machine ..... 14
  - Lowering the Hopper without Power ..... 15
  - Transporting the Machine ..... 15
  - Lifting the Machine ..... 16
- Maintenance ..... 17
  - Recommended Maintenance Schedule(s) ..... 17
  - Pre-Maintenance Procedures ..... 18
    - Releasing the Cushion for Rear Access ..... 18
    - Using the Cylinder Lock ..... 18
  - Lubrication ..... 19
    - Greasing the Machine ..... 19
  - Engine Maintenance ..... 19
    - Servicing the Air Cleaner ..... 19
    - Checking the Engine-Oil Level ..... 20
    - Changing the Engine Oil and Filter ..... 21
    - Servicing the Spark Plugs ..... 22
    - Cleaning the Blower Housing ..... 23
  - Fuel System Maintenance ..... 24
    - Replacing the Fuel Filter ..... 24
    - Draining the Fuel Tank ..... 24
    - Removing the Fuel Tank ..... 25
  - Electrical System Maintenance ..... 25
    - Servicing the Battery ..... 25
    - Servicing the Fuses ..... 27
  - Drive System Maintenance ..... 27
    - Servicing the Tracks ..... 27
    - Servicing the Drive Belt ..... 29
  - Controls System Maintenance ..... 30
    - Adjusting the Motion-Control Levers ..... 30
    - Brake Maintenance ..... 31
  - Hydraulic System Maintenance ..... 32
    - Servicing the Hydraulic Drive System ..... 32
    - Servicing the Hydraulic Lift System ..... 34
    - Checking the Hydraulic Lines ..... 36
  - Cleaning ..... 37
    - Removing Debris from the Machine ..... 37
- Storage ..... 38

# Safety

Improper use or maintenance of the machine can result in injury. To reduce the potential for injury, comply with these safety instructions and always pay attention to the safety-alert symbol (Figure 2), which means **Caution**, **Warning**, or **Danger**—personal safety instruction. Failure to comply with the instruction may result in personal injury or death.

## Safe Operating Practices

### **⚠ WARNING**

**Engine exhaust contains carbon monoxide, an odorless gas that is lethal if inhaled.**

**Do not run the engine indoors or in an enclosed area.**

### Training

- Read the *Operator's Manual* and other training material. If the operator(s) or mechanic(s) cannot read this manual, it is the owner's responsibility to explain this material to them.
- Become familiar with the safe operation of the equipment, operator controls, and safety signs.
- All operators and mechanics should be trained. The owner is responsible for training the users.
- Never let children or untrained people operate or service the equipment. Local regulations may restrict the age of the operator.
- The owner/user can prevent and is responsible for accidents or injuries occurring to himself or herself, other people or property.

### Preparation

- Wear appropriate clothing including hard hat, eye protection, long pants, substantial, slip-resistant footwear, and hearing protection. Tie back long hair. Do not wear loose jewelry.
- Inspect the area where the equipment is to be used and ensure that all objects are removed from the machine before use.
- Know and mark the locations of all utility lines.
- Use extra care when handling fuels. They are flammable and vapors are explosive.
  - Extinguish all cigarettes, cigars, pipes, and other sources of ignition.
  - Use only an approved container
  - Do not remove the fuel cap or fill the fuel tank while the engine is running or hot.
  - Do not add or drain fuel in an enclosed space.

- Do not store the machine or fuel container where there is an open flame, spark, or pilot light, such as on a water heater or other appliance.
- If you spill fuel, do not attempt to start the engine; avoid creating any source of ignition until the fuel vapors have dissipated.
- Check that the operator's presence controls, safety switches, and shields are attached and functioning properly. Do not operate the machine unless they are functioning properly.

### Operation

- Use your full attention while operating the machine. Do not engage in any activity that causes distractions; otherwise, injury or property damage may occur.
- Never run an engine in an enclosed or poorly ventilated area.
- Operate the machine only in good light, keeping away from holes and hidden hazards.
- Ensure that all drives are in neutral before starting the engine. Start the engine only from the operator's position.
- Do not operate the machine with the guards not securely in place. Be sure all interlocks are attached, adjusted properly, and functioning properly.
- Do not change the engine governor setting or overspeed the engine.
- Stop the machine on level ground, lower the hopper, shut off the engine, and remove the key before leaving the operator's position for any reason.
- Never carry passengers and keep pets and bystanders away.
- Slow down and use caution when making turns and crossing roads and sidewalks.
- Do not operate the machine while ill, tired, or under the influence of alcohol or drugs.
- Use care when loading or unloading the machine into a trailer or truck.
- Use care when approaching blind corners, shrubs, trees, or other objects that may obscure vision.
- Ensure that the area is clear of other people before operating the machine. Shut off the machine if anyone enters the area.
- Never leave a running machine unattended.
- Do not exceed the rated operating capacity, as the machine may become unstable which may result in loss of control.
- Never jerk the controls; use a steady motion.

- Watch for traffic when operating near or crossing roadways.
- Do not touch parts that may be hot from operation. Allow them to cool before attempting to maintain, adjust, or service.
- Check for overhead clearances (i.e., branches, doorways, electrical wires) before driving under any objects and do not contact them.
- Ensure that you operate the machine in areas where there are no obstacles close to you. Failure to maintain adequate distance from trees, walls, and other barriers may result in injury as the machine backs up during operation if you are not attentive to the surroundings. Operate the machine only in areas where there is sufficient clearance for the operator to safely maneuver the product.
- Locate the pinch point areas marked on the machine and keep hands and feet away from these areas.
- Operate the machine only in good visibility and appropriate weather conditions. Do not operate the machine when there is the risk of lighting.
- Do not overload the hopper and always keep the load level when operating the machine.
- Identify hazards at the base of the slope. Do not operate the machine near drop-offs, ditches, embankments, water or other hazards. The machine could suddenly roll over if a wheel or track goes over the edge or the edge collapses. Keep a safe distance (twice the width of the machine) between the machine and any hazard.
- Avoid starting, stopping, or turning the machine on a slope. Avoid making sudden changes in speed or direction; turn slowly and gradually.
- Keep all movements on slopes slow and gradual. Do not make sudden changes in speed or direction.
- Do not operate the machine under any conditions where traction, steering, or stability is in question. Be aware that operating the machine on wet grass, across slopes or downhill may cause the machine to lose traction. Loss of traction to the wheels or tracks may result in sliding and a loss of braking and steering. The machine can slide even if the wheels or tracks are stopped.
- Remove or mark obstacles such as ditches, holes, ruts, bumps, rocks or other hidden hazards. Tall grass can hide obstacles. Uneven terrain could overturn the machine.
- If you lose control of the machine, step off and away from the direction of travel of the machine.

## Slope Operation

- Slopes are a major factor related to loss-of-control and tip-over accidents, which can result in severe injury or death. The operator is responsible for safe slope operation. operating the machine on any slope requires extra caution. Before using the machine on a slope, you must:
  - Review and understand the slope instructions in the manual and on the machine.
  - Evaluate the site conditions of the day to determine if the slope is safe for machine operation. Always use common sense and good judgment when performing this evaluation. Changes in the terrain, such as moisture, can quickly affect the operation of the machine on a slope.
- Raising the hopper on a slope affects the stability of the machine. Keep the hopper in the lowered position when on slopes.
- When operating on a slope, fold the platform up and walk behind the machine until it is on flat ground.
- **Operate up and down slopes with the heavy end of the machine uphill.** Weight distribution changes with a full hopper. A full hopper makes the front of the machine the heavy end, so when traveling up or down slopes with a full hopper, walk-behind the machine with the full hopper uphill.

## Maintenance and Storage

- Let the engine cool before storing and do not store the machine near an open flame.
- Engage the parking brake, shut off the engine, remove the key, and wait for all movement to stop before adjusting, cleaning, or repairing the machine.
- Clean debris from drives, mufflers, and the engine to help prevent fires. Clean up oil or fuel spills.
- Do not store fuel near flames or drain indoors.
- Park the machine on level ground. Never allow untrained personnel to service the machine.
- Use jack stands to support components when required.
- Carefully release pressure from components with stored energy.
- Disconnect the battery, negative terminal first and positive terminal last, before making any repairs. Connect the battery positive terminal first and negative terminal last.
- Keep your hands and feet away from moving parts. If possible, do not make adjustments with the engine running.

- Charge batteries in an open, well-ventilated area, away from spark and flames. Unplug the charger before connecting or disconnecting it from the battery. Wear protective clothing and use insulated tools.
- Keep all parts in good working condition and all hardware tightened. Replace all worn or damaged decals.
- Use the cylinder lock to secure the hopper in the raised position.
- Keep nuts and bolts tight. Keep equipment in good condition.
- Never tamper with safety devices.
- Use only genuine Toro replacement parts to ensure that original standards are maintained.
- Battery acid is poisonous and can cause burns. Avoid contact with skin, eyes, and clothing. Protect your face, eyes, and clothing when working with a battery.
- Battery gases can explode. Keep cigarettes, sparks, and flames away from the battery.
- Keep your body and hands away from pinhole leaks or nozzles that eject high-pressure hydraulic fluid. Use cardboard or paper to find hydraulic leaks; never use your hands. Hydraulic fluid escaping under pressure can penetrate skin and cause injury requiring surgery within a few hours by a qualified surgeon; otherwise, gangrene may result.

## Safety and Instructional Decals



Safety decals and instructions are easily visible to the operator and are located near any area of potential danger. Replace any decal that is damaged or missing.



115-4212

decal115-4212

1. Hydraulic-fluid level
2. Read the *Operator's Manual*.
3. Warning—do not touch the hot surface.

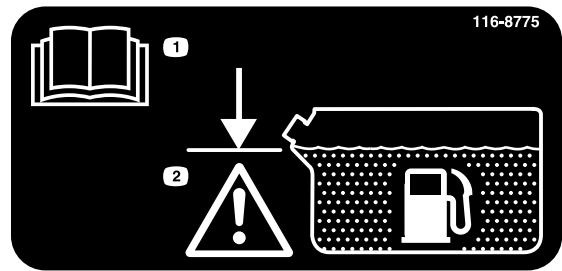

116-8775

decal116-8775

1. Read the *Operator's Manual*.
2. Warning—fill to the bottom of the filler neck; do not overfill the tank.



115-4858

decal115-4858

1. Crushing hazard of hands or feet—install the cylinder lock.

**⚠ WARNING:** This product can expose you to chemicals including gasoline engine exhaust, which is known to the State of California to cause cancer, and carbon monoxide, which is known to the State of California to cause birth defects or other reproductive harm. For more information go to [www.P65Warnings.ca.gov](http://www.P65Warnings.ca.gov). For more information, please visit [www.toro.com/CAProp65](http://www.toro.com/CAProp65).

### CALIFORNIA SPARK ARRESTER WARNING

Operation of this equipment may create sparks that can start fires around dry vegetation. A spark arrester may be required. The operator should contact local fire agencies for laws or regulations relating to fire prevention requirements.

133-5619

decal133-5619

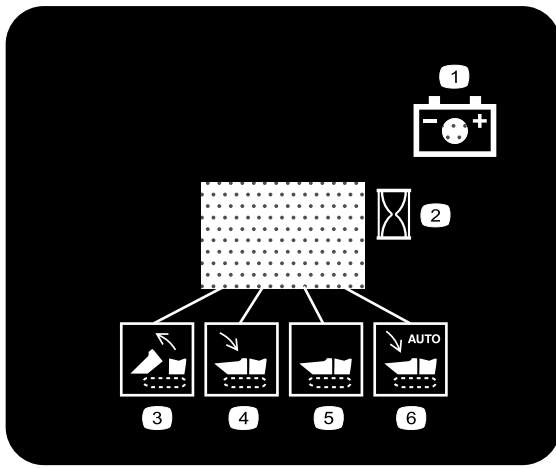

132-8961

decal132-8961

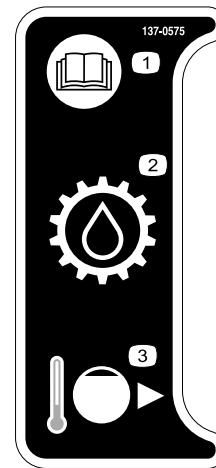

137-0575

decal137-0575

1. Battery charging condition
2. Hour meter
3. Hopper is raising.
4. Hopper is lowering.
5. Hopper is down.
6. Hopper is lowering automatically.

1. Read the *Operator's Manual*.
2. Transmission fluid
3. Cold-fill line

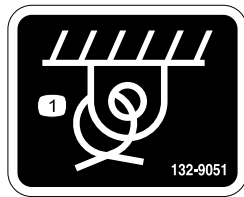

132-9051

decal132-9051

1. Tie-down point

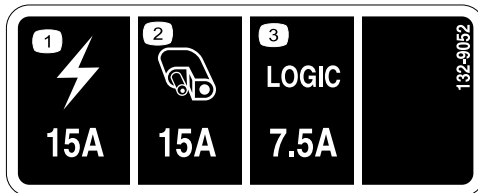

132-9052

decal132-9052

1. Main (15 A)
2. Auxiliary (15 A)
3. Logic (7.5 A)

**MBTX-2500 QUICK REFERENCE AID**

**CHECK/SERVICE DAILY**

1. OIL LEVEL, DAILY
2. AIR FILTER
3. GREASE CYLINDER
4. CHECK TRACK
5. CLEAN MACHINE

**FLUID SPECIFICATION / CHANGE INTERVALS**

SEE OPERATOR'S MANUAL FOR INITIAL CHANGE	FLUID TYPE	CAPACITY	CHANGE INTERVALS		PART NO.
			FLUID	FILTER	
ENGINE OIL	10W20	2 QTS.	100 HRS.	100 HRS.	
HYDRAULIC OIL (CYLINDER CIRCUIT)	100W PREMIUM HYD FLUID	96 OZ.	300 HRS.	300 HRS.	1-033750
HYDRAULIC OIL (TRANSMISSIONS)	100W HYDRAULIC OIL	208 OZ.	300 HRS.	300 HRS.	137-3772
FUEL SYSTEM	97 OCTANE W/ALCOHOL RESISTION				
AIR FILTER				100 HRS.	

**SERVICE PARTS**

PART #	PART	QTY	LOCATION	132-8812	TRACK	2	G
125-0339	RUB SHIRT	2	A	125-2416	ROAD WHEEL ASM	14	H
132-8833	CYLINDER HYDRAULIC	1	B	132-8833	WHEEL DRIVE MUD BUGGY	2	I
132-8821	CYLINDER HYDRAULIC SEAL KIT	1	C	104-1182	BATTERY	1	J
132-8838	PULLEY-ENGINE (WELDED)	1	D	AU113864	SWITCH,ROCKER	1	K
116-8626	PULLEY IDLER	1	E	ST47182	LATCH,RUBBER	1	L
104-5745	TENSIONER WHEEL ASM	2	F	132-8858	BELT	1	M

137-8899

decal137-8899

1. Read the *Operator's Manual*.

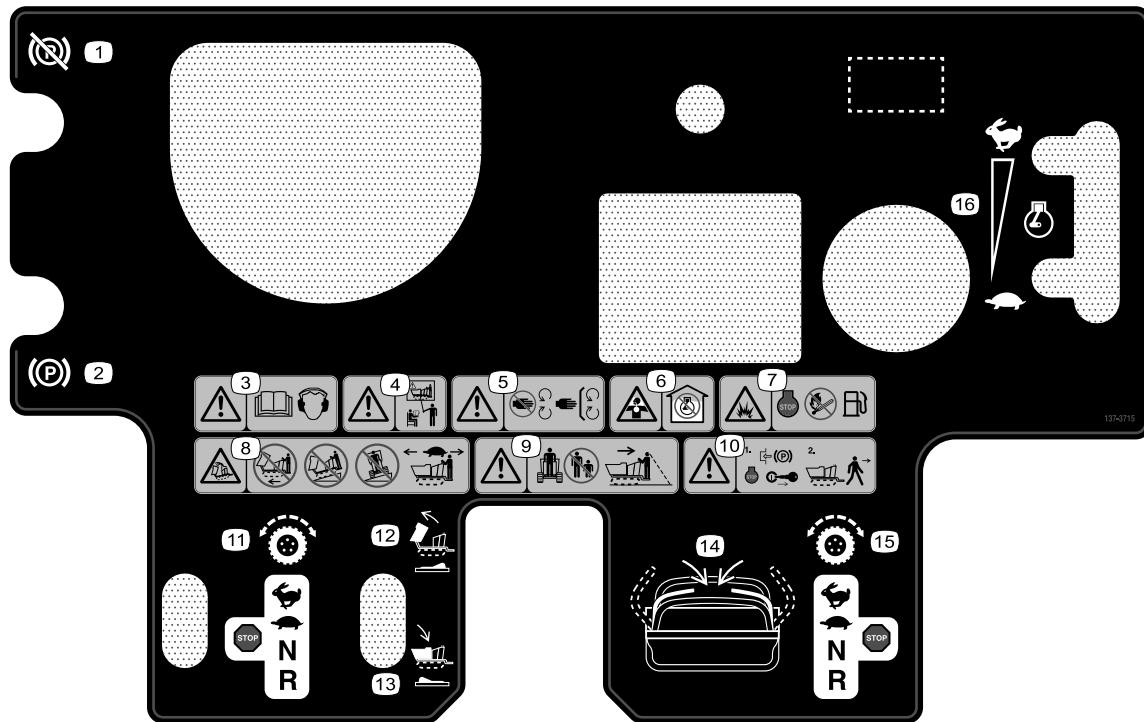

**137-3715**

decal137-3715

- |  |   |                                     |
|--|---|-------------------------------------|
| 1. Parking-brake release   | 7. Explosion hazard—shut off the engine before adding fuel; no fire, open flames, or smoking when adding fuel.  | 13. Lower hopper                    |
| 2. Parking brake   | 8. Machine tipping hazard—do not drive forward with the hopper raised; do not drive down slopes with the hopper raised; do not drive across slopes with the hopper raised; drive slowly with the hopper down. | 14. Move the handles in to operate. |
| 3. Warning—read the <i>Operator's Manual</i> ; hearing protection must be worn.                    | 9. Warning—keep bystanders a safe distance away from the machine; watch behind you when moving in reverse.  | 15. Right traction controls         |
| 4. Warning—all operators should be trained before operating the machine.                           | 10. Warning—engage the parking brake, shut off the engine, and remove the key before leaving the operator's position.   | 16. Engine-speed control            |
| 5. Warning—keep away from moving parts; keep all guards and covers in place.                       | 11. Left traction controls  |                                     |
| 6. Poisonous fumes or toxic gases, asphyxiation hazard—do not run the engine in an enclosed space. | 12. Raise hopper  |                                     |



# Product Overview

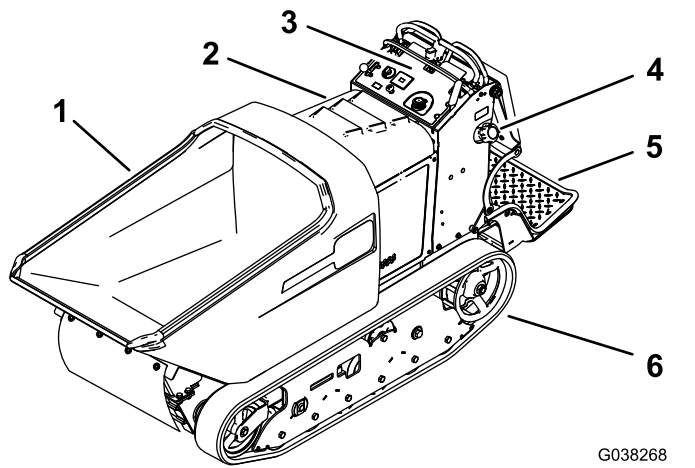

G038268  
g038268

Figure 3

- |                  |                      |
|------------------|----------------------|
| 1. Hopper        | 4. Fuel-tank cap     |
| 2. Hood          | 5. Operator platform |
| 3. Control panel | 6. Track             |

## Controls

Become familiar with all the controls (Figure 4) before you start the engine and operate the machine.

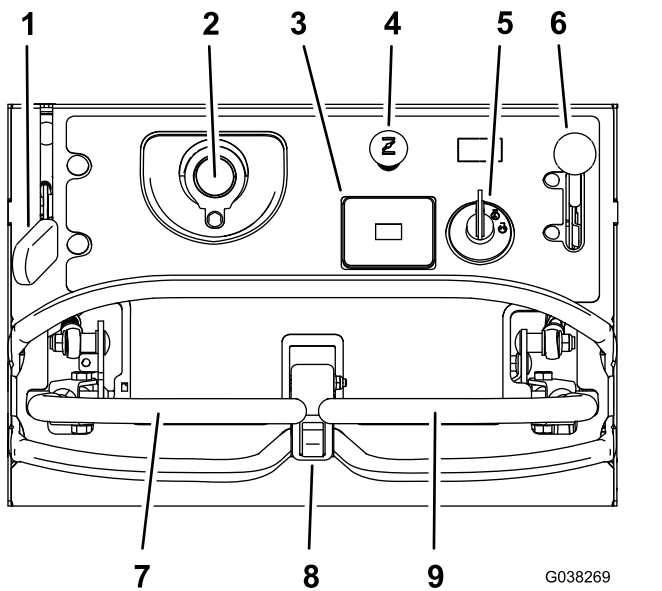

G038269  
g038269

Figure 4

- |                        |                               |
|------------------------|-------------------------------|
| 1. Parking-brake lever | 6. Throttle lever             |
| 2. Hydraulic-tank cap  | 7. Left motion-control lever  |
| 3. Hour meter          | 8. Dump switch                |
| 4. Choke control       | 9. Right motion-control lever |
| 5. Key switch          |                               |

## Parking Brake Lever

To engage the parking brake, pull back the lever. (Figure 4).

To disengage the parking brake, push the lever forward.

## Hour Meter

The hour meter records the number of hours the engine has operated. It operates when the engine is running. Use these times for scheduling regular maintenance (Figure 4).

## Choke Control

Use the choke to start a cold engine. Pull the choke knob up to engage it. Push the choke knob down to disengage it (Figure 4).

## Key Switch

Use the key switch to start the engine (Figure 4). The switch has 3 positions: OFF, RUN, and START.

## Throttle Lever

The throttle lever is variable between the FAST and SLOW positions (Figure 4).

## Motion-Control Levers

Use the motion-control levers to drive the machine forward and reverse and to turn either direction (Figure 4).

## Dump Switch

Use the dump switch to dump and lower the hopper. If you hold the switch down 0.2 to 1.3 seconds, the hopper fully lowers automatically.

# Specifications

**Note:** Specifications and design are subject to change without notice.

Width	90.2 cm (35-1/2 inches)
Length	268.0 cm (105-1/2 inches)
Height	121.2 cm (47.7 inches)
Weight	734 kg (1,619 lb)
Hopper capacity	0.45 m <sup>3</sup> (16 ft <sup>3</sup> )
Maximum load	1,134 kg (2,500 lb)
Discharge Height	38.1 cm (15 inches)

## Attachments/Accessories

A selection of Toro approved attachments and accessories is available for use with the machine to enhance and expand its capabilities. Contact your Authorized Service Dealer or authorized Toro distributor or go to [www.Toro.com](http://www.Toro.com) for a list of all approved attachments and accessories.

To ensure optimum performance and continued safety certification of the machine, use only genuine Toro replacement parts and accessories. Replacement parts and accessories made by other manufacturers could be dangerous, and such use could void the product warranty.

# Operation

**Note:** Determine the left and right sides of the machine from the normal operating position.

**Important:** Before operating, check the fuel and oil level, and remove debris from the machine. Also, ensure that the area is clear of people and debris.

## Adding Fuel

- For best results, use only clean, fresh (less than 30 days old), unleaded gasoline with an octane rating of 87 or higher ((R+M)/2 rating method).
- **ETHANOL:** Gasoline with up to 10% ethanol (gasohol) or 15% MTBE (methyl tertiary butyl ether) by volume is acceptable. Ethanol and MTBE are not the same. Gasoline with 15% ethanol (E15) by volume is not approved for use. Never use gasoline that contains more than 10% ethanol by volume, such as E15 (contains 15% ethanol), E20 (contains 20% ethanol), or E85 (contains up to 85% ethanol). Using unapproved gasoline may cause performance problems and/or engine damage which may not be covered under warranty.
- **Do not** use gasoline containing methanol.
- **Do not** store fuel either in the fuel tank or fuel containers over the winter unless you use a fuel stabilizer.
- **Do not** add oil to gasoline.

## **⚠ DANGER**

In certain conditions, fuel is extremely flammable and highly explosive. A fire or explosion from fuel can burn you and others and can damage property.

- Fill the fuel tank outdoors, in an open area, when the engine is cold. Wipe up any fuel that spills.
- Never fill the fuel tank inside an enclosed trailer.
- Do not fill the fuel tank completely full. Add fuel to the fuel tank until the level is 6 to 13 mm (1/4 to 1/2 inch) below the bottom of the filler neck. This empty space in the tank allows fuel to expand.
- Never smoke when handling fuel and stay away from an open flame or where fuel fumes may be ignited by a spark.
- Store fuel in an approved container and keep it out of the reach of children. Never buy more than a 30-day supply of fuel.
- Do not operate without entire exhaust system in place and in proper working condition.

## **⚠ DANGER**

In certain conditions during fueling, static electricity can be released causing a spark, which can ignite the fuel vapors. A fire or explosion from fuel can burn you and others and can damage property.

- Always place fuel containers on the ground away from your vehicle before filling.
- Do not fill fuel containers inside a vehicle or on a truck or trailer bed because interior carpets or plastic truck bed liners may insulate the container and slow the loss of any static charge.
- When practical, remove fuel-powered equipment from the truck or trailer and refuel the equipment with its wheels on the ground.
- If this is not possible, then refuel such equipment on a truck or trailer from a portable container rather than from a fuel-dispenser nozzle.
- If you must use a fuel-dispenser nozzle, keep the nozzle in contact with the rim of the fuel tank or container opening at all times until fueling is complete.

## **⚠ WARNING**

Fuel is harmful or fatal if swallowed. Long-term exposure to vapors can cause serious injury and illness.

- Avoid prolonged breathing of vapors.
- Keep your face away from nozzle and fuel tank or conditioner opening.
- Keep fuel away from eyes and skin.

## Using Stabilizer/Conditioner

Use fuel stabilizer/conditioner in the machine to keep the fuel fresh longer when used as directed by the fuel-stabilizer manufacturer.

**Important:** Do not use fuel additives containing methanol or ethanol.

Add the amount of fuel stabilizer/conditioner to fresh fuel as directed by the fuel-stabilizer manufacturer.

## Filling the Fuel Tank

Fuel-tank capacity: 40.1 L (10.6 US gallons)

1. Clean the area around the fuel-tank cap.
2. Remove the cap.
3. Add fuel until it is at the bottom of the filler neck.

**Note:** Do not fill the fuel tank completely full. The empty space in the tank allows the fuel to expand.

4. Install the cap.

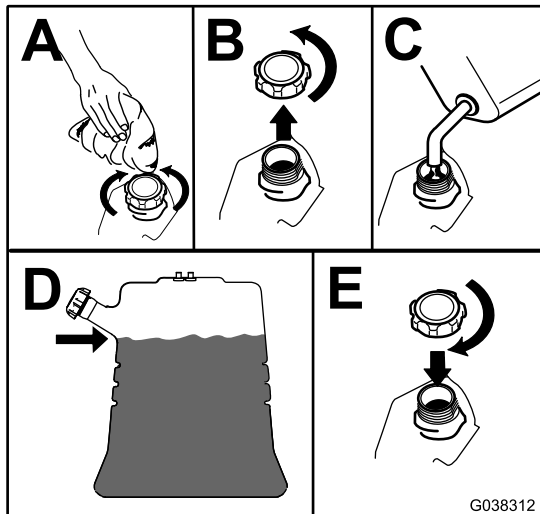

Figure 5

g038312

## Performing Daily Maintenance

Before starting the engine each day, perform the following procedures:

- Check the engine-oil level—refer to [Checking the Engine-Oil Level \(page 20\)](#).
- Check the hydraulic-fluid level for the drive system—refer to [Checking the Hydraulic-Fluid Level for the Drive System \(page 32\)](#)
- Check the hydraulic-fluid level for the lift system—refer to [Checking the Hydraulic-Fluid Level for the Lift System \(page 34\)](#).

## Operating the Parking Brake

Always engage the parking brake when you stop the machine or leave it unattended. Before each use, check the parking brake for proper operation.

### ⚠ CAUTION

Children or bystanders may be injured if they move or attempt to operate the machine while it is unattended.

Remove the ignition key and engage the parking brake whenever you leave the machine unattended.

## Engaging the Parking Brake

Pull the parking-brake lever rearward into the ENGAGED position ([Figure 6](#)).

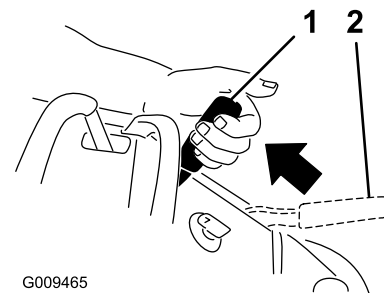

Figure 6

g009465

1. Parking brake—ENGAGED position
2. Parking brake—RELEASED position

## Releasing the Parking Brake

Push the parking-brake lever forward ([Figure 6](#)).

# Operating the Throttle

The throttle control moves between FAST and SLOW positions (Figure 7).

Always use the FAST position when moving the machine.

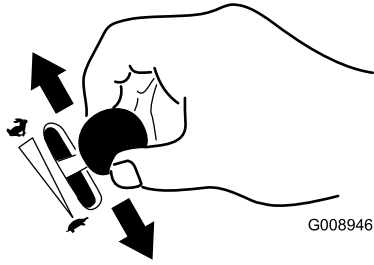

Figure 7

g008946

# Operating the Choke

Use the choke to start a cold engine.

1. Pull up the choke knob to engage the choke before using the key switch (Figure 8).

**Note:** Ensure that you fully engage the choke. You may need to hold the knob up when you use the key switch.

2. Push down the choke to disengage the choke after the engine has started (Figure 8).

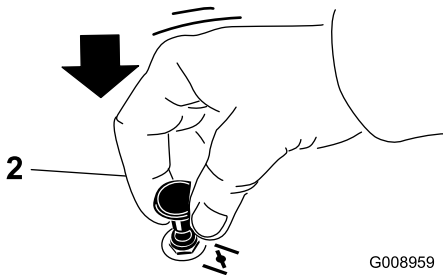
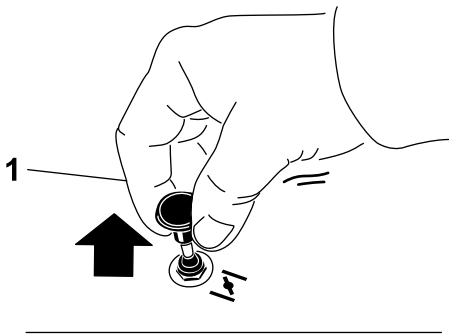

Figure 8

G008959

g008959

1. ON position

2. OFF position

# Starting the Engine

1. Engage the parking brake.
2. Engage the choke.

**Note:** A warm or hot engine may not require choking. You may need to repeat the starting cycle when you start the engine for the first time after you have filled a completely empty fuel system with fuel.

3. Move the throttle between the FAST and SLOW positions.
4. Turn the key switch to the START position.
5. When the engine starts, disengage the choke.

**Important:** Do not engage the starter for more than 5 seconds at a time. If the engine fails to start, allow a 15-second cool-down period between attempts. Failure to follow these instructions can burn out the starter.

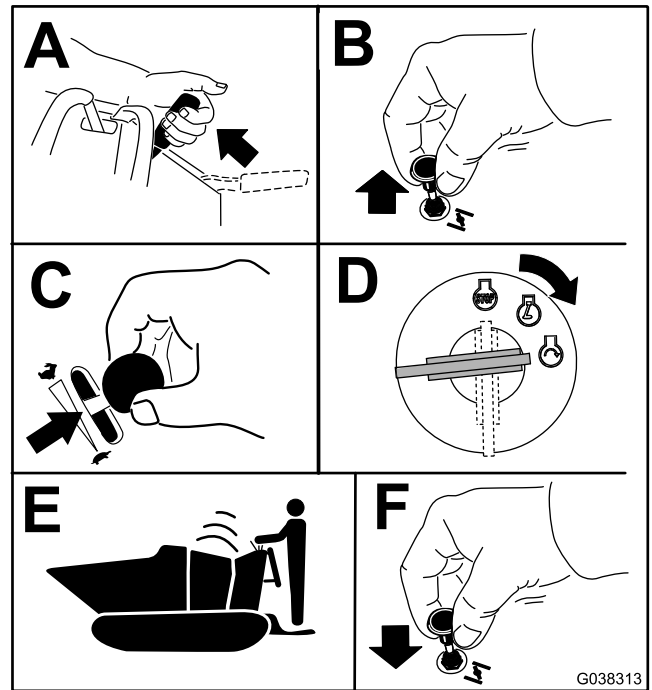

Figure 9

g038313

## Shutting Off the Engine

1. Move the throttle between the FAST and SLOW positions.
2. Engage the parking brake.
3. Turn the key switch to the OFF position and remove the key.

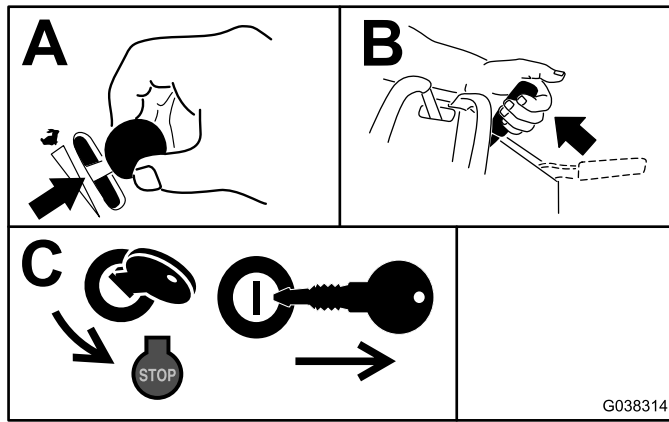

Figure 10

## Removing Debris from the Machine

1. Park the machine on a level surface, move the motion-control levers to the NEUTRAL-LOCK position, engage the parking brake, and lower the hopper.
2. Shut off the engine and remove the key. Allow the engine to cool.
3. Clean the inside of the hopper using a hose.  
**Important:** Do not use a hammer to remove material from the inside of the hopper; this may cause damage to the machine.
4. Clean any debris from under the hopper.
5. Wipe away debris from the air cleaner.
6. Clean any debris buildup on the engine and in the transmission with a brush or blower.

**Important:** Blow out dirt rather than wash it out. If you use water, keep it away from electrical parts and hydraulic valves. Do not use a high-pressure washer. High-pressure washing can damage the electrical system and hydraulic valves or deplete grease.

## Operating the Hopper

**Hopper capacity:** 1134 kg (2,500 lb)

Know the load capacity of the machine and never exceed it. This machine normally operates on uneven, unpaved, bumpy, and/or inclined surfaces—adjust the load accordingly.

1. Position the machine where you intend to dump the load.
2. Dump the hopper by pushing the top of the dump switch (Figure 11).
3. Lower the hopper by pushing the bottom of the dump switch (Figure 11).

**Note:** If you hold the bottom of the switch 0.2 to 1.3 seconds, the hopper fully lowers automatically.

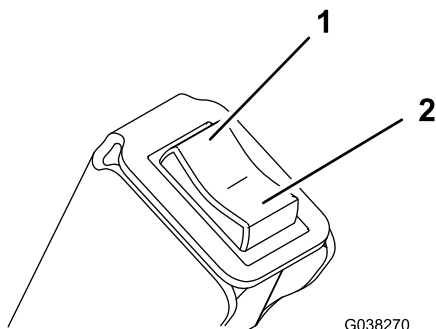
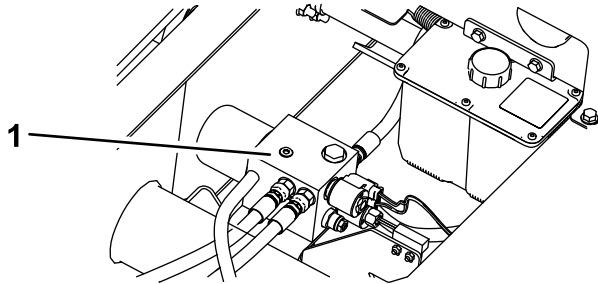

Figure 11

1. Dump the hopper.
2. Lower the hopper.

# Lowering the Hopper without Power

1. Install the cylinder lock; refer to [Installing the Cylinder Lock \(page 18\)](#).
2. Ensure that the tub is empty.
3. Place a large drain pan under the hydraulic-manifold block ([Figure 12](#)).



g186548

**Figure 12**

1. Hydraulic-manifold block

4. Disconnect the hose fittings in the manifold block and allow the fluid to drain into the pan.

**Note:** Dispose of the used fluid at a certified recycling center.

5. Connect the hose fittings.
6. Use a hoist or have 2 people hold up the hopper and remove the cylinder lock.
7. Carefully lower the hopper to the machine frame.

# Transporting the Machine

Use a heavy-duty trailer or truck with full-width ramps to transport the machine. Ensure that the trailer or truck has all the necessary brakes, lighting, and marking as required by law. Please carefully read all the safety instructions. Knowing this information could help you, your family, pets or bystanders avoid injury. Refer to your local ordinances for trailer and tie-down requirements.

**Important:** Do not operate or drive the machine on roadways.

1. Lower the hopper.
2. If using a trailer, connect it to the towing vehicle and connect the safety chains.
3. If applicable, connect the trailer brakes.
4. Carefully load the machine onto the trailer or truck.
5. Shut off the engine, remove the key, and set the brake.
6. Use the metal tie-down loops on the machine to securely fasten the machine to the trailer or truck with straps, chains, cable, or ropes ([Figure 13](#)).

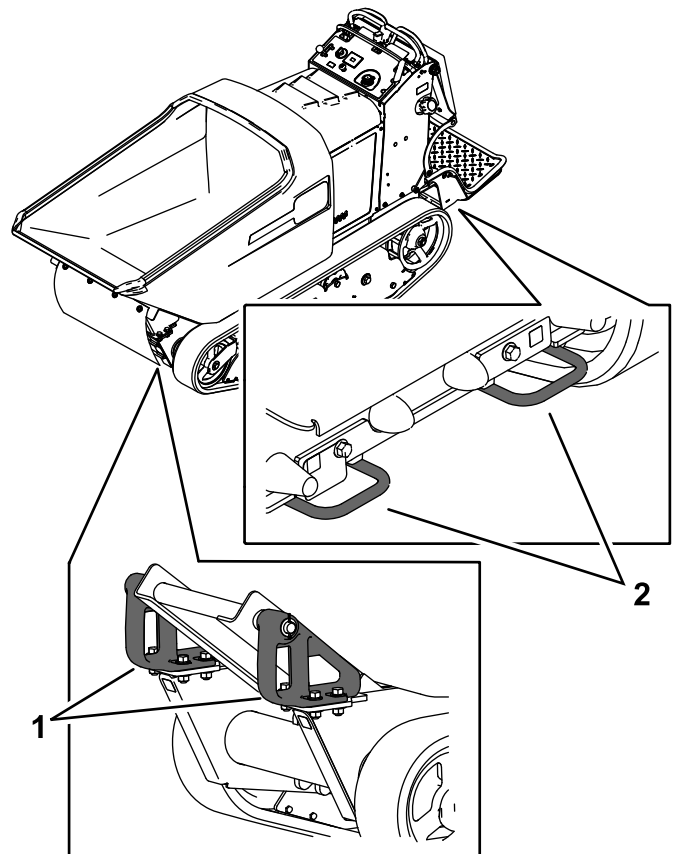

g185890

**Figure 13**

1. Front tie-down loops
2. Rear tie-down loops

# Lifting the Machine

Hoist the machine using 2 lift points under the hopper and 2 rear tie-down loops. Tilt the hopper forward to locate the 2 lift loops and attach a chain or straps at each of the loops as shown in [Figure 14](#).

**Note:** Take up the slack in the chain or straps to properly balance the unit.

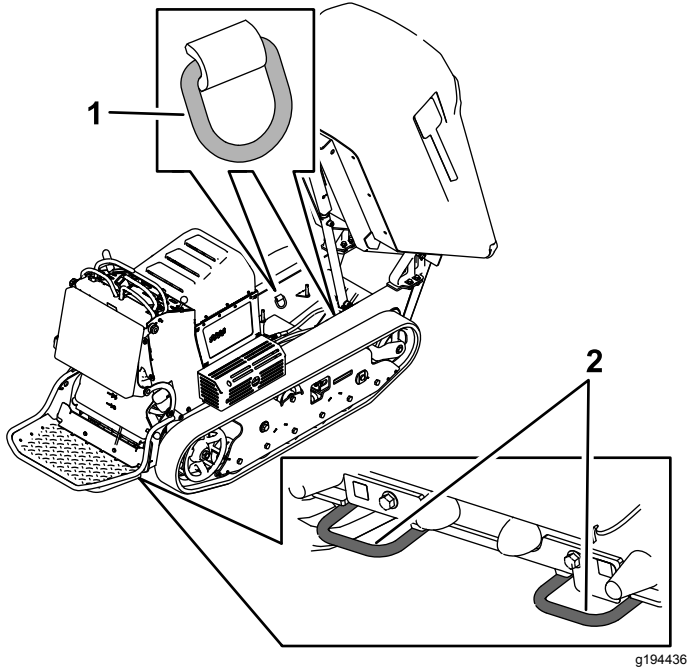

**Figure 14**

1. Lift points under hopper      2. Rear tie-down loops
-



# Maintenance

**Note:** Determine the left and right sides of the machine from the normal operating position.

## Recommended Maintenance Schedule(s)

Maintenance Service Interval	Maintenance Procedure
After the first 10 hours	<ul style="list-style-type: none"> <li>• Check and adjust the track tension (every 10 hours until 50 hours).</li> </ul>
Before each use or daily	<ul style="list-style-type: none"> <li>• Check the engine-oil level.</li> <li>• Clean the blower housing (more often under extremely dusty, dirty conditions).</li> <li>• Check the condition of the track.</li> <li>• Check the parking brake operation.</li> <li>• Check the hydraulic-fluid level for the drive system.</li> <li>• Check the hydraulic-fluid level for the lift system.</li> <li>• Remove debris from the machine.</li> <li>• Check for loose fasteners.</li> </ul>
Every 25 hours	<ul style="list-style-type: none"> <li>• Service or replace the air-cleaner foam element (more often under extremely dusty, dirty conditions).</li> </ul>
Every 40 hours	<ul style="list-style-type: none"> <li>• Check the hydraulic lines for leaks, loose fittings, kinked lines, loose mounting supports, wear, and deterioration.</li> </ul>
Every 50 hours	<ul style="list-style-type: none"> <li>• Grease the machine (grease immediately after every washing).</li> <li>• Check the battery.</li> <li>• Check and adjust the track tension.</li> </ul>
Every 100 hours	<ul style="list-style-type: none"> <li>• Replace the air-cleaner paper element (more often under extremely dusty, dirty conditions).</li> <li>• Change the engine oil and the engine-oil filter.</li> <li>• Check the spark plug.</li> <li>• Remove the cooling shrouds and clean the cooling areas (more often under extremely dusty, dirty conditions).</li> <li>• Replace the fuel filter (more often under dusty, dirty conditions).</li> <li>• Inspect the drive belt.</li> <li>• Clean dirt buildup in the chassis.</li> </ul>
Every 300 hours	<ul style="list-style-type: none"> <li>• Replace the spark plug.</li> <li>• Check the road wheels.</li> <li>• Replace the drive belt.</li> <li>• Change the hydraulic fluid and filter for the drive system.</li> <li>• Change the hydraulic fluid for the lift system.</li> <li>• Replace the hydraulic filter for the lift system.</li> </ul>

**Important:** Refer to your engine owner's manual for additional maintenance procedures.

### **▲ CAUTION**

If you leave the key in the switch, someone could accidentally start the engine and seriously injure you or other bystanders.

Remove the key from the switch before you perform any maintenance.

# Pre-Maintenance Procedures

## Releasing the Cushion for Rear Access

You can release the cushion for rear access to the machine for maintenance or adjustment.

1. Lower the platform.
2. Loosen the twist knobs on each side of the machine (Figure 15).

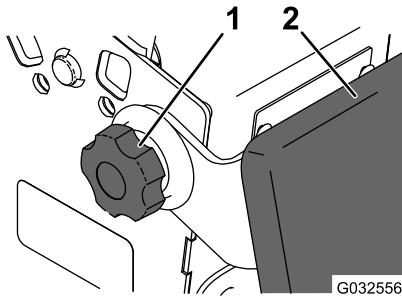

Figure 15

1. Twist knob
2. Cushion

3. Remove the cushion and lower it to the platform.
4. Perform any maintenance or adjustment on the machine.
5. Raise the cushion, and slide it onto the pins on both sides of the machine.
6. Tighten the twist knobs.

## Using the Cylinder Lock

### Installing the Cylinder Lock

1. Park the machine on a level surface, move the motion-control levers to the NEUTRAL-LOCK position, engage the parking brake, and fully raise the hopper.
2. Remove the 2 cotterless pins securing the cylinder lock to the machine.
3. Slide the cylinder lock over the lift-cylinder rod and secure with the cotterless pins (Figure 16).

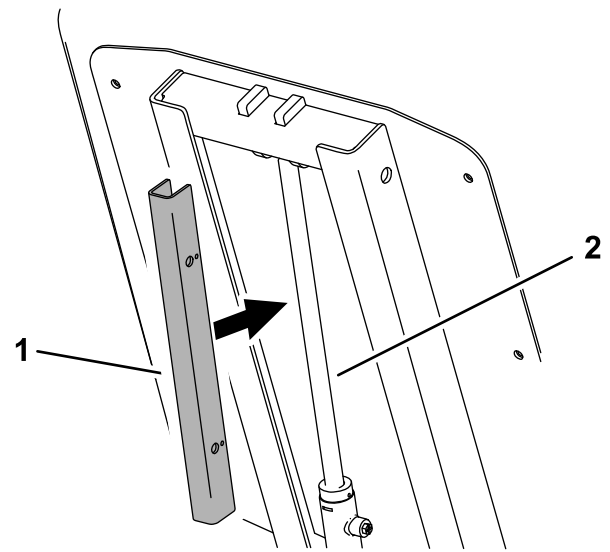

Figure 16

1. Cylinder lock
2. Lift-cylinder rod

4. Slowly lower the hopper until the cylinder lock contacts the cylinder body and rod end.

### Removing and Storing the Cylinder Lock

**Important:** Remove the cylinder lock from the lift-cylinder rod and fully secure it in the storage position before operating the machine.

1. Start the machine.
2. Fully raise the hopper.
3. Shut off the engine.
4. Remove the cotterless pins securing the cylinder lock.
5. Place the cylinder lock on the posts inside the machine frame and secure with the cotterless pins.
6. Lower the hopper.

# Lubrication

## Greasing the Machine

**Service Interval:** Every 50 hours

When operating the machine under normal conditions, lubricate all grease fittings for the bearings and bushings with No. 2 lithium grease. Lubricate the bearings and bushings immediately after every washing, regardless of the interval listed. Apply a light coating of oil onto the control cables.

Cylinder pivots (2)—[Figure 17](#)

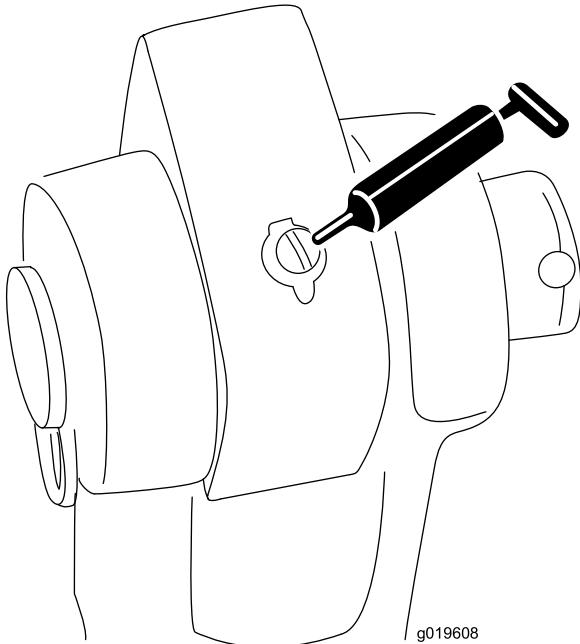

**Figure 17**

g019608

# Engine Maintenance

## Servicing the Air Cleaner

**Service Interval:** Every 25 hours—Service or replace the air-cleaner foam element (more often under extremely dusty, dirty conditions).

Every 100 hours—Replace the air-cleaner paper element (more often under extremely dusty, dirty conditions).

**Note:** Operating the engine with loose or damaged air-cleaner components could allow unfiltered air into the engine, causing premature wear and failure.

**Note:** Service the air cleaner more often under extremely dusty, dirty conditions.

## Removing the Elements

1. Rotate the latches outward.
2. Remove the cover to access the air-cleaner elements ([Figure 18](#)).

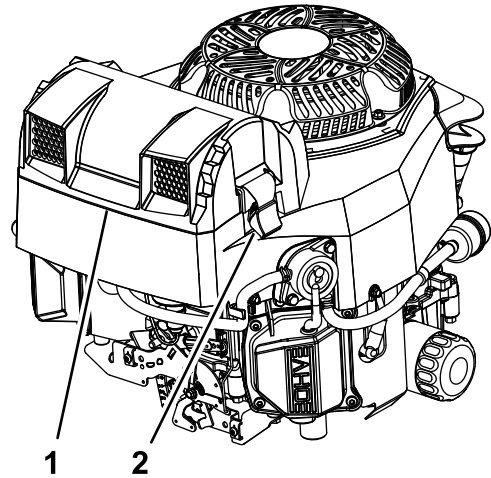

**Figure 18**

g243624

1. Air-cleaner cover
2. Air-cleaner latch

3. Remove the foam and paper elements ([Figure 19](#)).
4. Remove the foam element from the paper element ([Figure 19](#)).

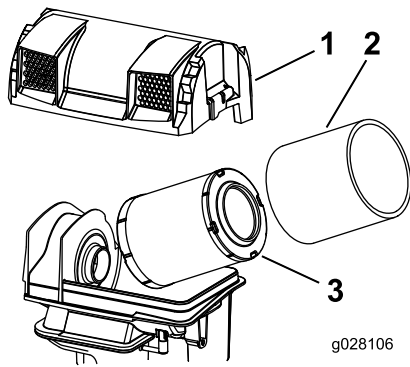

Figure 19

1. Air-cleaner cover
2. Foam element
3. Paper element

## Servicing the Foam Element

1. Wash the foam element in warm water and detergent.
2. Rinse and allow it to air dry.
3. Lightly oil the foam element with new oil and squeeze out excess oil.

## Servicing the Paper Element

1. Gently tap the paper element to dislodge dirt.

**Note:** Do not wash the paper element or use pressurized air, as this damages the element.

**Note:** Replace a dirty, bent, or damaged element. Handle the new element carefully; do not use if the sealing surfaces are bent or damaged.

2. Clean the air-cleaner base as required, and check the condition.

## Installing the Elements

1. Install the foam element onto the paper element.
2. Install the elements onto the air-cleaner base (Figure 19).
3. Install the cover, and secure it with the latches (Figure 18).

# Checking the Engine-Oil Level

**Service Interval:** Before each use or daily

**Important:** Remember to add 80% of the oil, and then gradually fill it to the Full mark on the dipstick.

**Important:** Do not run the engine with the oil level above the Full mark or below the low mark. Otherwise, you may damage the engine.

1. Park the machine on a level surface, move the motion-control levers to the NEUTRAL-LOCK position, engage the parking brake, and lower the hopper.
2. Shut off the engine, and remove the key. Allow the engine to cool.
3. Open the cowl.
4. Check the engine-oil level as shown in Figure 20.

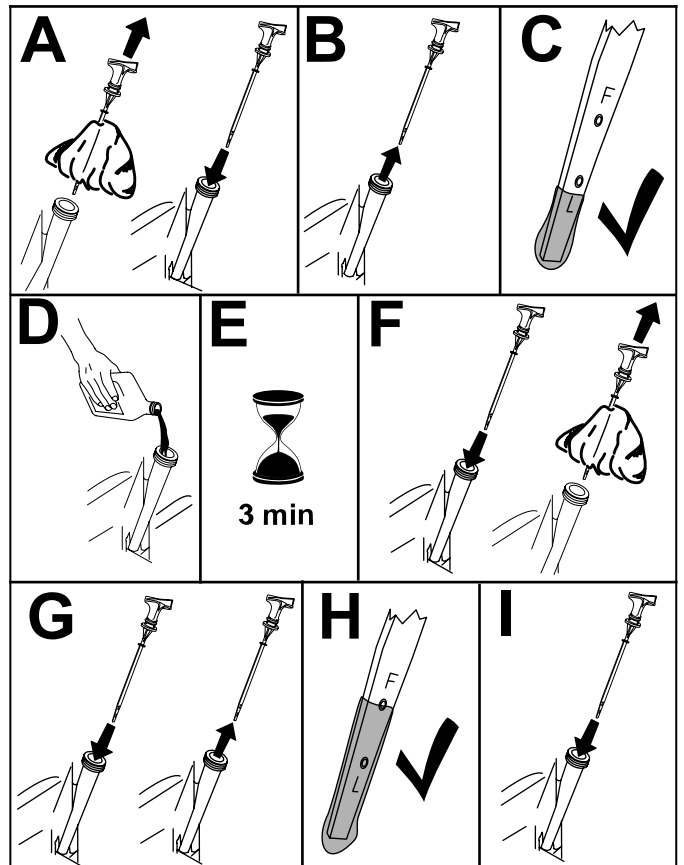

Figure 20

g243578

# Changing the Engine Oil and Filter

**Service Interval:** Every 100 hours

**Oil Type:** Detergent oil (API service SJ or higher)

**Engine Oil Capacity:** 1.9 L (64 fl oz)

**Viscosity:** Refer to the table below.

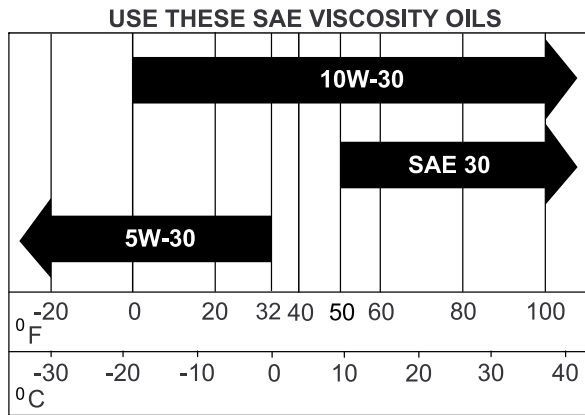
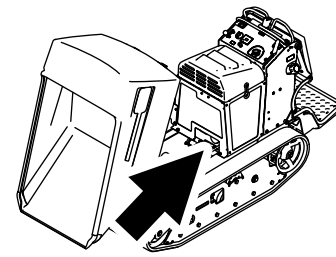

Figure 21

Change the engine oil while the engine is warm.

**Note:** Dispose of the used oil at a recycling center.

1. Park the machine on a level surface, move the motion-control levers to the NEUTRAL-LOCK position, engage the parking brake, raise the hopper, and install the cylinder lock.
2. Shut off the engine and remove the key.
3. Perform the following steps to change the engine oil:
  - A. Remove the drain plug and allow all of the existing oil to drain out of the engine (Figure 22).



g185888

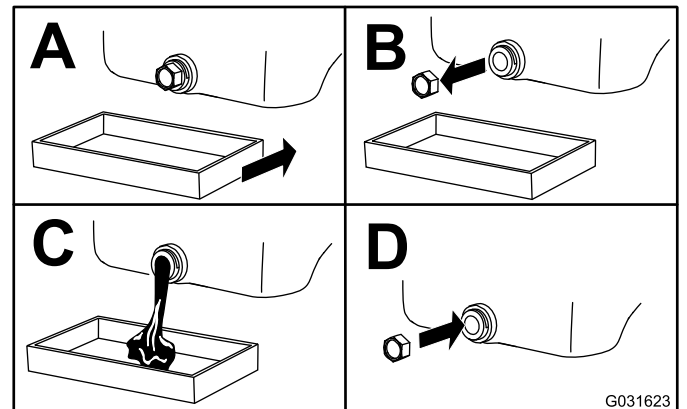

Figure 22

g031623

B. Install the drain plug (Figure 22). Torque the plug to 13.6 N·m (10 ft-lb).

4. Change the engine-oil filter as shown in Figure 23.

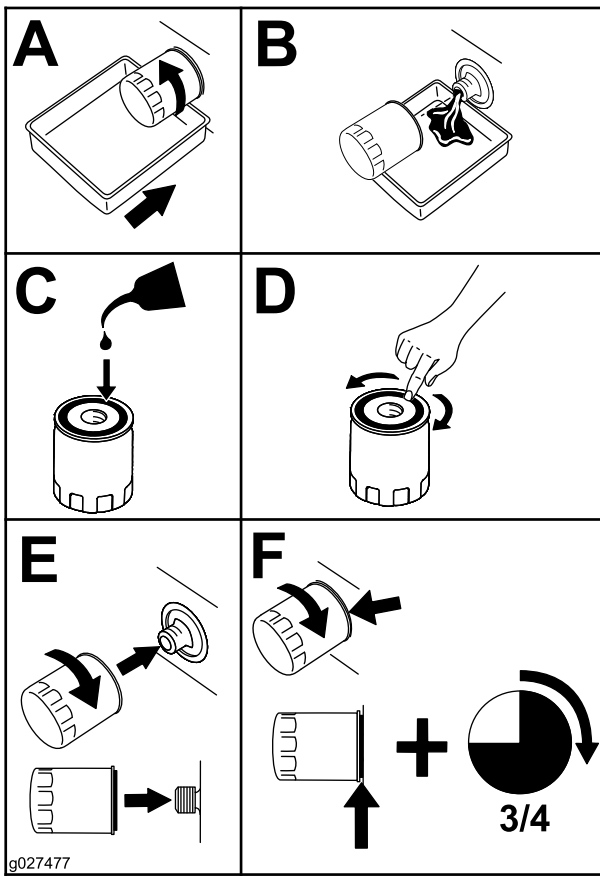

Figure 23

- Slowly pour approximately 80% of the specified oil into the filler tube (Figure 24).

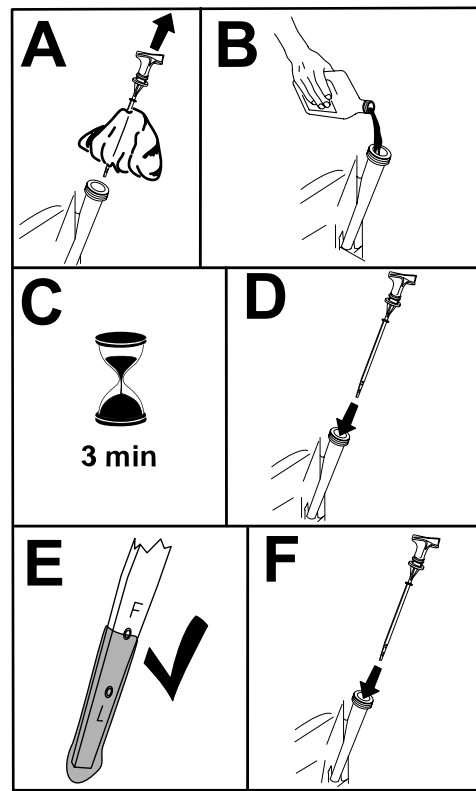

Figure 24

g243623

## Servicing the Spark Plugs

**Service Interval:** Every 100 hours—Check the spark plug.

Every 300 hours—Replace the spark plug.

The spark plugs are RFI compliant. Equivalent alternate brand plugs can also be used.

**Type:** Champion XC12YC

**Air Gap:** 0.76 mm (0.03 inch)

## Removing the Spark Plug

1. Park the machine on a level surface, move the motion-control levers to the NEUTRAL-LOCK position, engage the parking brake, and lower the hopper.
2. Shut off the engine and remove the key. Allow the engine to cool.
3. Before removing the spark plug(s), clean the area around the base of the plug to keep dirt and debris out of the engine.
4. Remove the spark plug (Figure 25).

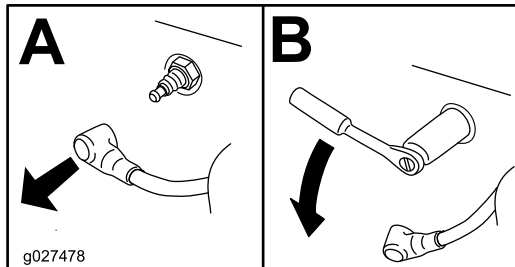

Figure 25

## Installing the Spark Plug

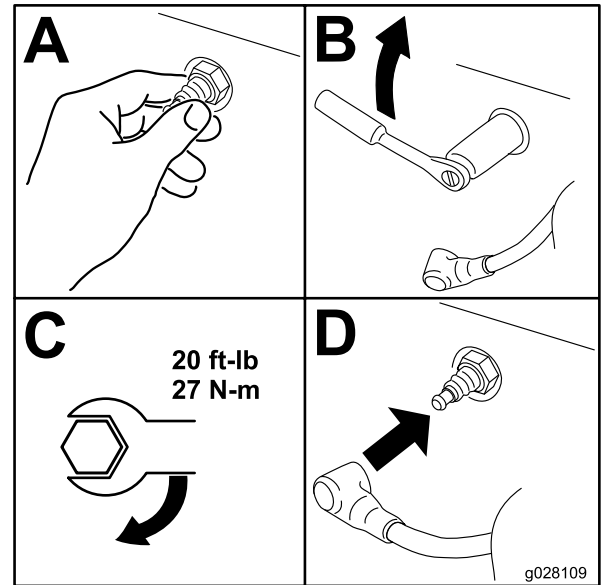

Figure 27

## Checking the Spark Plug

**Important:** Do not clean the spark plug(s). Always replace the spark plug(s) when it has: a black coating, worn electrodes, an oily film, or cracks.

**Note:** If you see light brown or gray on the insulator, the engine is operating properly. A black coating on the insulator usually means the air cleaner is dirty.

Set the gap to 0.76 mm (0.03 inch).

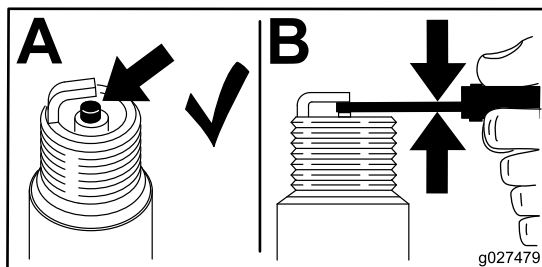

Figure 26

**Important:** Ensure that the spark plug is tightened to the correct torque specification. A loose spark plug may cause the cylinder head to overheat, while an overtightened spark plug may cause damage to the threads in the cylinder head.

## Cleaning the Blower Housing

Every 100 hours/Yearly (whichever comes first)

To ensure proper cooling, ensure that the grass screen, cooling fins, and other external surfaces of the engine are kept clean at all times.

Ensure that the cooling shrouds are installed.

**Important:** Operating the engine with a blocked grass screen, dirty or plugged cooling fins, and/or cooling shrouds removed causes engine damage due to overheating.

# Fuel System Maintenance

## Replacing the Fuel Filter

**Service Interval:** Every 100 hours/Yearly (whichever comes first) (more often under dusty, dirty conditions).

1. Park the machine on a level surface, move the motion-control levers to the NEUTRAL-LOCK position, engage the parking brake, and lower the hopper.
2. Shut off the engine, and remove the key. Allow the engine to cool.
3. Replace the fuel filter as shown in [Figure 28](#).

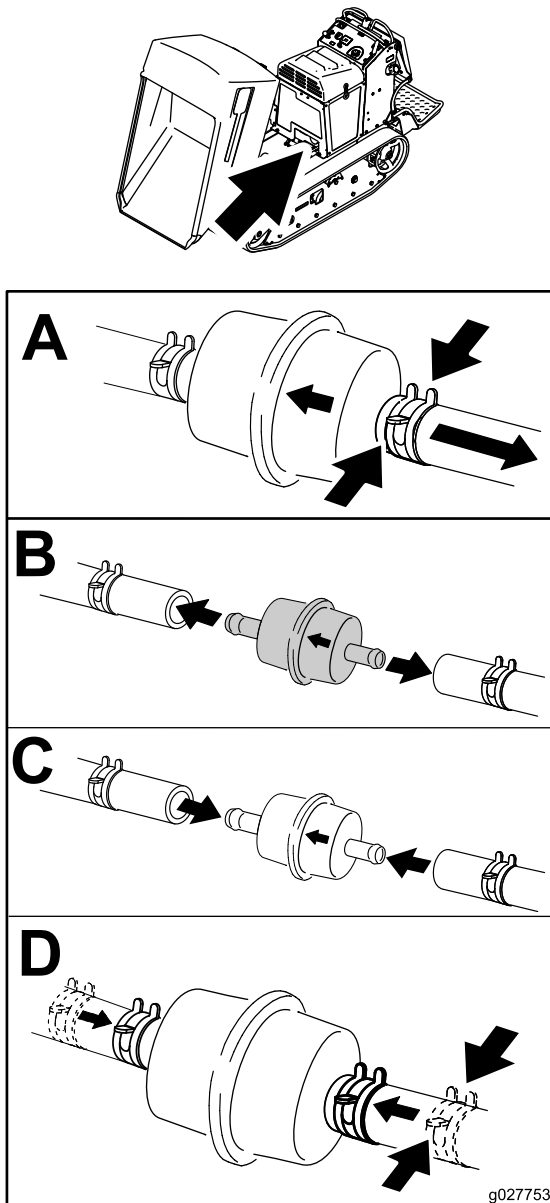

Figure 28

## Draining the Fuel Tank

You can drain the fuel tank by removing it and pouring the fuel out of the fill neck; refer to [Removing the Fuel Tank \(page 25\)](#). You can also drain the fuel tank by using a siphon in the following procedure.

### **⚠ DANGER**

**In certain conditions, fuel is extremely flammable and highly explosive. A fire or explosion from fuel can burn you and others and can damage property.**

- Drain fuel from the fuel tank when the engine is cold. Do this outdoors in an open area. Wipe up any fuel that spills.
- Never smoke when draining fuel and stay away from an open flame, or where a spark may ignite the fuel fumes.

1. Park the machine on a level surface, move the motion-control levers to the NEUTRAL-LOCK position, engage the parking brake, and lower the hopper.
2. Shut off the engine, and remove the key. Allow the engine to cool.
3. Clean around the fuel cap to prevent debris from getting into the fuel tank ([Figure 29](#)).
4. Remove the fuel cap.
5. Insert a syphon pump into the fuel tank.
6. Using the syphon pump, drain the fuel into a clean fuel can ([Figure 29](#)).
7. Wipe up any spilled fuel.

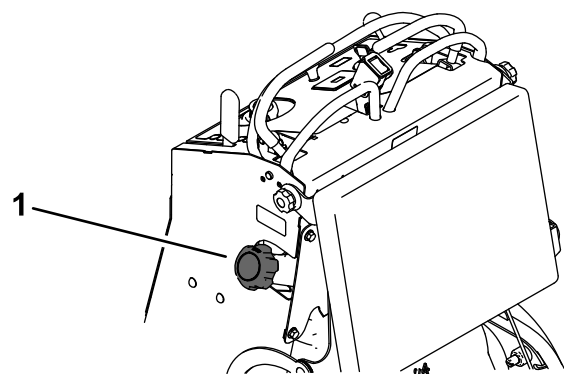

Figure 29

1. Fuel cap



# Removing the Fuel Tank

1. Lower the platform.
2. Release the cushion; refer to [Releasing the Cushion for Rear Access](#) (page 18).
3. Remove the cross bracket ([Figure 30](#)).

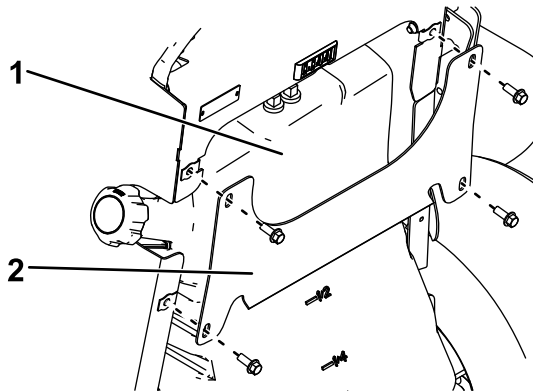

Figure 30

g186223

1. Fuel tank
2. Cross bracket

4. Remove the fuel tank and set it on the operator platform.

**Note:** If you want to move the fuel tank further from the machine, remove the fuel and vent lines from the top of the tank.

# Electrical System Maintenance

## Servicing the Battery

Service Interval: Every 50 hours

### **⚠ DANGER**

Battery electrolyte contains sulfuric acid, which is fatal if consumed and causes severe burns.

Do not drink electrolyte and avoid contact with skin, eyes or clothing. Wear safety glasses to shield your eyes and rubber gloves to protect your hands.

## Removing the Battery

### **⚠ WARNING**

Battery terminals or metal tools could short against metal machine components, causing sparks. Sparks can cause the battery gasses to explode, resulting in personal injury.

- When removing or installing the battery, do not allow the battery terminals to touch any metal parts of the machine.
- Do not allow metal tools to short between the battery terminals and metal parts of the machine.

### **⚠ WARNING**

Incorrect battery-cable routing could damage the machine and cables, causing sparks. Sparks can cause the battery gasses to explode, resulting in personal injury.

- Always disconnect the negative (black) battery cable before disconnecting the positive (red) cable.
- Always connect the positive (red) battery cable before connecting the negative (black) cable.

1. Park the machine on a level surface, move the motion-control levers to the NEUTRAL-LOCK position, engage the parking brake, and lower the hopper.
2. Shut off the engine, and remove the key. Allow the engine to cool.
3. Remove the negative battery cable from the battery ([Figure 31](#)).

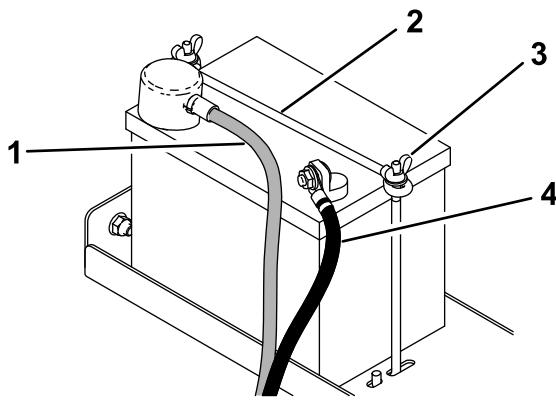

**Figure 31**

g185906

- |                           |                           |
|---------------------------|---------------------------|
| 1. Positive battery cable | 3. Wing nut (2)           |
| 2. Securing rod           | 4. Negative battery cable |

- Remove the positive battery cable from the battery (Figure 31).
- Remove the 2 wing nuts, securing rod, and the battery (Figure 31).

## Installing the Battery

- Place the battery on the platform and secure it using the 2 wing nuts and the securing rod (Figure 31).
- Install the positive battery cable to the battery (Figure 31).
- Install the negative battery cable to the battery (Figure 31).

## Charging the Battery

### **⚠ WARNING**

Charging the battery produces gasses that can explode.

Never smoke near the battery and keep sparks and flames away from battery.

**Important:** Always keep the battery fully charged (1.265 specific gravity) to prevent battery damage when the temperature is below 0°C (32°F).

- Remove the battery from the chassis; refer to [Removing the Battery \(page 25\)](#).
- Perform the following steps to check the electrolyte level:
  - Ensure that the cell covers are free from dirt and debris.
 

**Important:** Dirt and debris that enters the battery cells causes damage to the battery.
  - Remove the covers from the top of the cells.
  - Ensure that the electrolyte solution covers the lead plates. Use distilled water to top off the solution level, if needed.
- Ensure that the filler caps are installed on the battery.
- Charge the battery for 1 hour at 25 to 30 A or 6 hours at 4 to 6 A.
- When the battery is fully charged, unplug the charger from the electrical outlet, and disconnect the charger leads from the battery posts (Figure 32).
- Install the battery onto the machine and connect the battery cables; refer to [Installing the Battery \(page 26\)](#).

**Note:** Do not run the machine with the battery disconnected; electrical damage may occur.

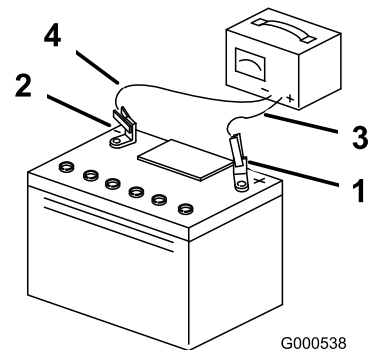

G000538

g000538

**Figure 32**

- |                          |                           |
|--------------------------|---------------------------|
| 1. Positive battery post | 3. Red (+) charger lead   |
| 2. Negative battery post | 4. Black (-) charger lead |

# Servicing the Fuses

The electrical system is protected by fuses and requires no maintenance. If a fuse blows, check the component or circuit for a malfunction or short.

1. Release the cushion from the rear of the machine.
2. Pull out the fuse to remove or replace it (Figure 33).
3. Install the cushion to the rear of the machine.

**Note:** Ensure that the correct-size fuse is installed (Figure 33).

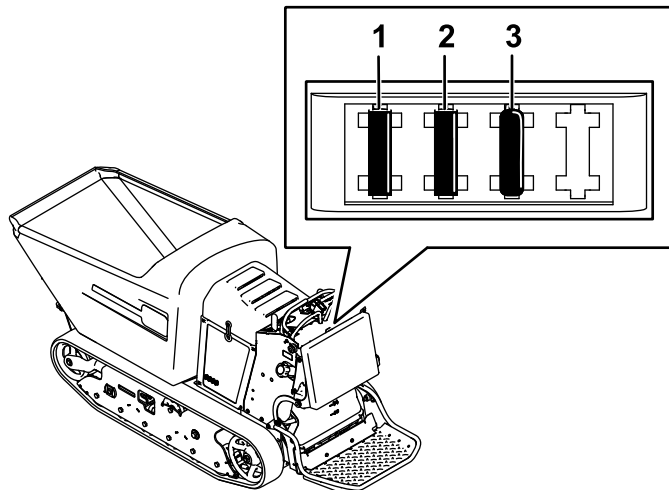

Figure 33

g189366

1. Main power fuse (15 A)
2. Auxiliary power fuse (15 A)
3. Logic fuse (7.5 A)

# Drive System Maintenance

## Servicing the Tracks

**Service Interval:** Before each use or daily—Check the condition of the track.

After the first 10 hours—Check and adjust the track tension (every 10 hours until 50 hours).

Every 50 hours—Check and adjust the track tension.

Every 300 hours—Check the road wheels.

## Cleaning the Tracks

1. Park the machine on a level surface, move the motion-control levers to the NEUTRAL-LOCK position, engage the parking brake, and lower the hopper.
2. Shut off the engine, and remove the key. Allow the engine to cool.
3. Lift/support the side of the machine to be worked on so that the track is 3 to 4 inches (7.6 to 10 cm) off the ground.
4. Using a water hose or pressure washer, remove dirt from each track system.

**Important:** Ensure that you use high-pressure water to wash only the track area. Do not use a high-pressure washer to clean the rest of the machine. Do not use high-pressure water between the drive sprocket and the machine or you may damage the motor seals. High-pressure washing can damage the electrical system and hydraulic valves or deplete grease.

**Important:** Ensure that you fully clean the road wheels, the front wheel, and the drive sprocket (Figure 34). The road wheels should rotate freely when clean.

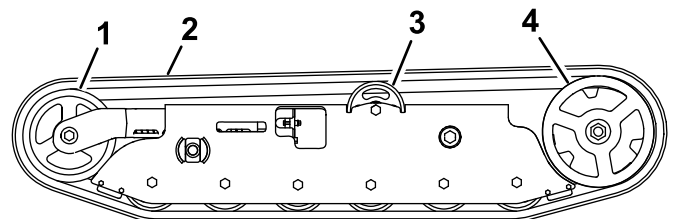

Figure 34

g186007

1. Front wheel
2. Track
3. Road wheel
4. Drive sprocket

## Adjusting the Track Tension

If you place the tab of the tensioning tool along the rear edge of the tension nut, the other end of the tensioning tool should align with the edge of the tension arm as shown in [Figure 35](#). If the distance is not correct, adjust the track tension using the following procedure:

**Note:** If the tensioning tool is not available, the distance between the nut and edge of the tension arm should be 7.1 cm (2-13/16 inch).

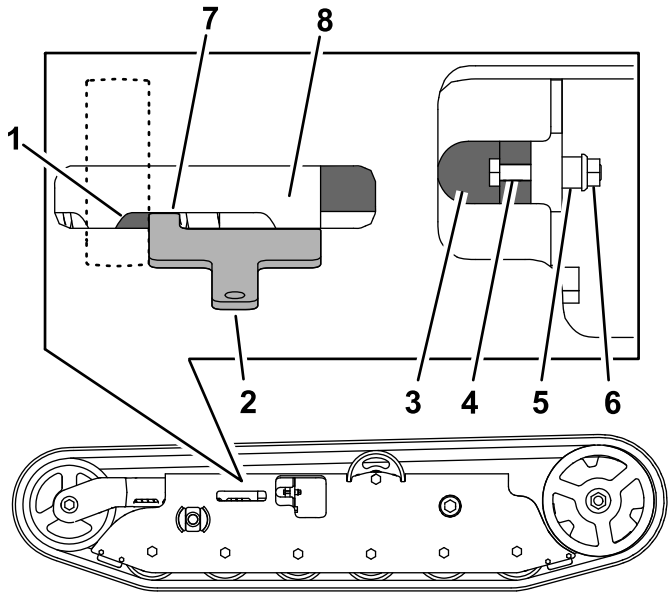

**Figure 35**

Left Track Shown

- |  |                |
|--|----------------|
| 1. Tension nut                                       | 5. Spacer      |
| 2. Tensioning tool (equal to 7.1 cm or 2-13/16 inch) | 6. Nut         |
| 3. Tensioning bolt                                   | 7. Tab         |
| 4. Bolt (1/4 x 1-5/8 inch)                           | 8. Tension arm |

1. Park the machine on a level surface, move the motion-control levers to the NEUTRAL-LOCK position, engage the parking brake, and lower the hopper.
2. Shut off the engine, and remove the key. Allow the engine to cool.
3. Clean the tracks with high-pressure water.

**Important:** Ensure that you use high-pressure water to wash only the track area. Do not use a high-pressure washer to clean the rest of the machine. Do not use high pressure water between the drive sprocket and the machine or you may damage the motor seals. High-pressure washing can damage the electrical system and hydraulic valves or deplete grease.

4. Raise the machine so that the tracks are off the ground.
5. Clean the drive sprocket, the front wheel, and the road wheels. The road wheels should spin freely when clean.
6. Remove the bolt (1/4 x 1-5/8 inch), spacer, and nut ([Figure 35](#)).
7. Turn the tensioning bolt to adjust the distance between the tension nut and the end tangent of the tension tube until the distance is correct, as shown in [Figure 35](#).
8. Align the closest notch in the tensioning bolt to the bolt hole and secure the tensioning bolt with the bolt (1/4 x 1-5/8 inch), spacer, and nut ([Figure 35](#)).

## Replacing the Tracks

Replace the tracks when they are badly worn.

1. Park the machine on a level surface, move the motion-control levers to the NEUTRAL-LOCK position, engage the parking brake, and lower the hopper.
2. Shut off the engine, and remove the key. Allow the engine to cool.
3. Lift/support the side of the machine to be worked on so that the track is 3 to 4 inches (7.6 to 10 cm) off the ground.
4. Remove the retaining bolt for the tensioning screw.
5. Release the drive tension by turning the tensioning screw clockwise ([Figure 35](#) and [Figure 36](#)).

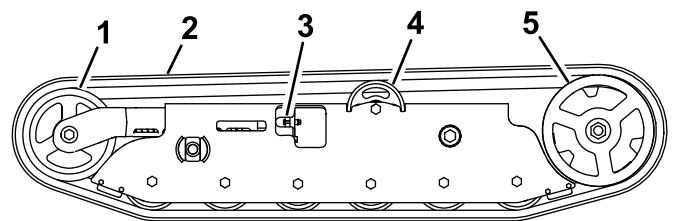

**Figure 36**

- |  |                   |
|--|-------------------|
| 1. Front wheel                         | 4. Road wheel     |
| 2. Track                               | 5. Drive sprocket |
| 3. Tensioning screw and retaining bolt |                   |

6. Remove the track at the top of the front wheel, peeling it off the wheel while rotating the track forward.
7. When the track is off the front wheel, remove it from the drive sprocket and road wheels ([Figure 36](#)).

8. Inspect the condition of the wheels. If the wheels show signs of wear, replace them at this time.
9. Beginning at the drive sprocket, coil the new track around the sprocket, ensuring that the lugs on the track fit between the spacers on the sprocket (Figure 36).
10. Push the track under the lugs and between the road wheels (Figure 36).
11. Starting at the bottom of the front wheel, install the track around the wheel by rotating the track rearward while pushing the lugs into the wheel.
12. Tension the track; refer to [Adjusting the Track Tension \(page 28\)](#).
13. Lower the machine to the ground.
14. Repeat steps 3 through 13 to replace the other track.

## Servicing the Drive Belt

### Inspecting the Drive Belt

**Service Interval:** Every 100 hours

1. Park the machine on a level surface, move the motion-control levers to the NEUTRAL-LOCK position, engage the parking brake, and lower the hopper.
2. Shut off the engine, and remove the key. Allow the engine to cool.
3. Release the cushion and remove the fuel tank; refer to [Releasing the Cushion for Rear Access \(page 18\)](#).
4. Inspect the belt (Figure 37). Replace the belt if it is worn; refer to [Replacing the Drive Belt \(page 29\)](#).

**Note:** The signs of a worn belt include squealing while the belt is rotating, frayed edges, burn marks, and cracks on the belt.

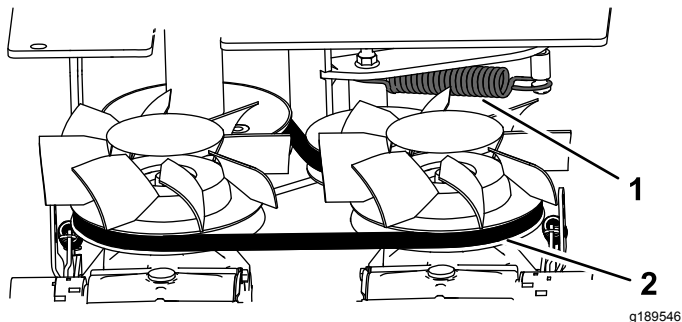

**Figure 37**

1. Extension spring
2. Belt

## Replacing the Drive Belt

**Service Interval:** Every 300 hours

1. Park the machine on a level surface, move the motion-control levers to the NEUTRAL-LOCK position, engage the parking brake, and lower the hopper.
2. Shut off the engine, and remove the key. Allow the engine to cool.
3. Release the cushion and remove the fuel tank; refer to [Removing the Fuel Tank \(page 25\)](#).
4. Raise the rear of the machine and support the machine on jack stands.
5. Remove the skid plate (Figure 35).

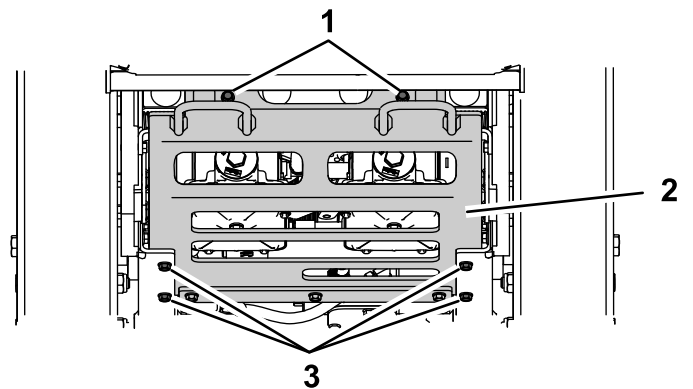

**Figure 38**

g203662

1. Rear bolt (2)
2. Skid plate
3. Side bolt (4)

6. Remove the extension spring (Figure 37).
7. Remove the 2 bolts and 2 nuts and loosen the 2 set screws on the coupler. Remove the gear pump from the pump mount (Figure 39).

**Note:** You do not need to remove the fittings from the pump.

# Controls System Maintenance

## Adjusting the Motion-Control Levers

If the motion-control levers do not align horizontally, adjust the right side motion-control lever.

1. Park the machine on a level surface, lower the hopper, engage the parking brake, shut off the engine, and remove the key.
2. Push the motion-control levers down out of the NEUTRAL-LOCK position (Figure 41).
3. Check if the right motion-control lever aligns horizontally with the left motion-control lever (Figure 41).

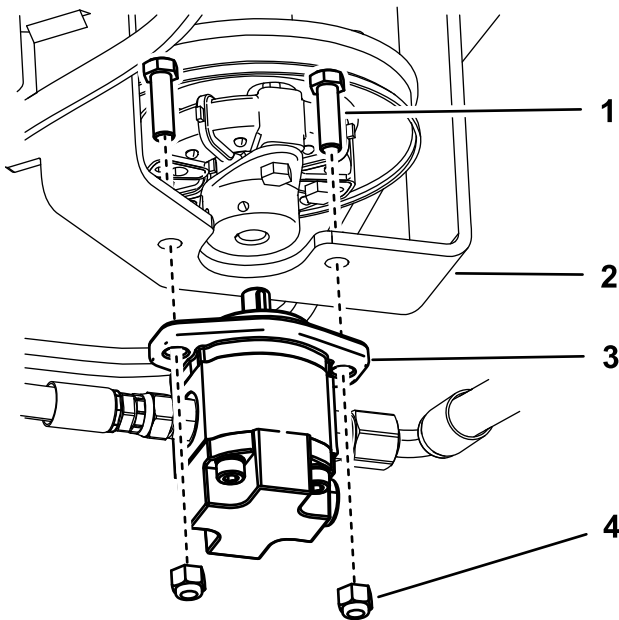

Figure 39

g189559

- |               |              |
|---------------|--------------|
| 1. Bolt (2)   | 3. Gear pump |
| 2. Pump mount | 4. Nut (2)   |

8. Remove the drive belt from the engine pulley and 2 transmission pulleys.

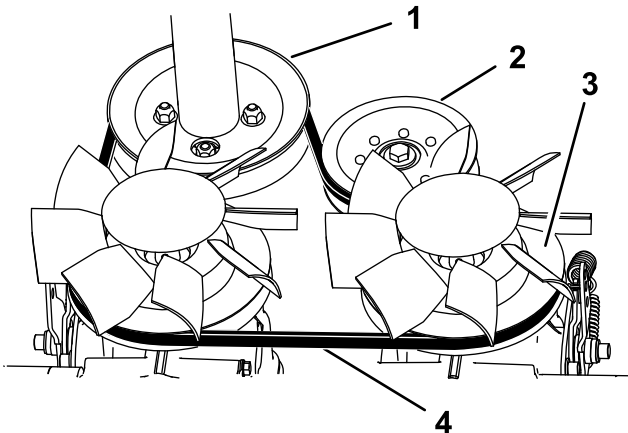

Figure 40

g189571

- |                  |                            |
|------------------|----------------------------|
| 1. Engine pulley | 3. Transmission pulley (2) |
| 2. Idler pulley  | 4. Belt                    |

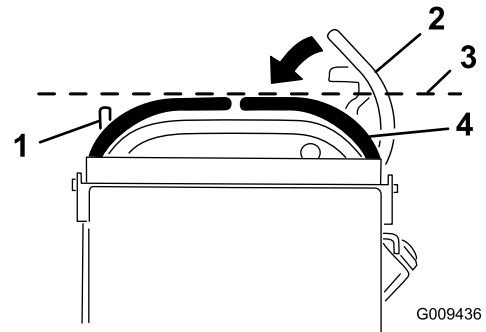

Figure 41

G009436

g009436

- |                               |  |
|-------------------------------|--|
| 1. Left motion-control lever  | 3. Check the horizontal alignment here                     |
| 2. Right motion-control lever | 4. Right motion-control lever in the Neutral-lock position |

4. To adjust the motion-control levers horizontally, you must adjust the cam.
5. Release the cushion from the rear of the machine.
6. Loosen the nut holding the cam (Figure 42).

9. Route the new belt around the engine pulley and 2 transmission pulleys (Figure 40).
10. Install the gear pump (Figure 39).
11. Install the extension spring (Figure 37).
12. Install the fuel tank; refer to [Removing the Fuel Tank \(page 25\)](#).
13. Raise the cushion.





# Hydraulic System Maintenance

## ⚠ WARNING

Hydraulic fluid escaping under pressure can penetrate skin and cause injury. Fluid injected into the skin must be surgically removed within a few hours by a doctor familiar with this form of injury; otherwise gangrene may result.

- Keep your body and hands away from pinhole leaks or nozzles that eject high-pressure hydraulic fluid.
- Use cardboard or paper to find hydraulic leaks; never use your hands.

## Servicing the Hydraulic Drive System

Expansion-tank capacity: 1.4 L (1.5 US qt)

Hydraulic-fluid type: Toro® HYPR-OIL™ 500

**Important:** Always use the correct hydraulic fluid. Unspecified fluids will damage the hydraulic system.

**Note:** Many hydraulic fluids are almost colorless, making it difficult to spot leaks. A red dye additive for the hydraulic system oil is available in 0.67 fl oz (20 ml) bottles. One bottle is sufficient for 4 to 6 gal (15 to 22 L) of hydraulic fluid. Order Part No. 44-2500 from your authorized Toro distributor.

## Checking the Hydraulic-Fluid Level for the Drive System

**Service Interval:** Before each use or daily

1. Park the machine on a level surface, move the motion-control levers to the NEUTRAL-LOCK position, engage the parking brake, and lower the hopper.
2. Shut off the engine, and remove the key. Allow the engine to cool.
3. Open the cowl.
4. Use the sight window to check the fluid level in the expansion tank (Figure 44).

**Note:** The fluid level should be at the fill line on the decal.

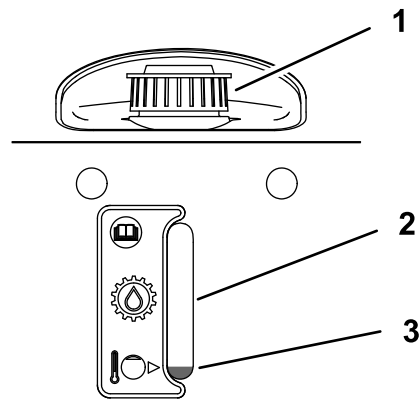

Figure 44

1. Expansion-tank cap
2. Sight window
3. Fluid at fill line

g203616

5. If the oil level is low, remove the cap lock and cap from the top of the expansion tank (Figure 45), and add enough of the specified hydraulic fluid to raise it to the proper level.

**Important:** Ensure that the expansion-tank fluid level is at the proper level. Overfilling the tank may cause fluid to purge out of the breather hole.

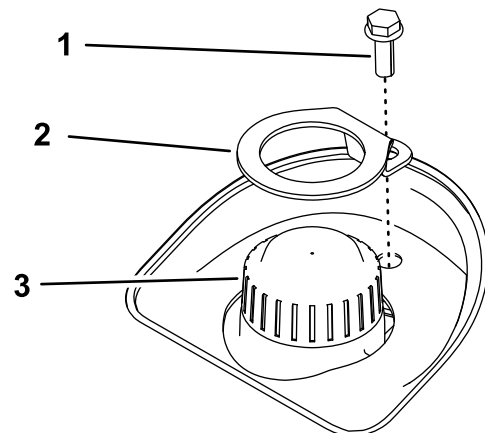

Figure 45

1. Bolt
2. Cap lock
3. Cap

g186038

6. Install the cap and cap lock. Wipe up any spilled hydraulic fluid.

## Changing the Hydraulic Fluid and Filter for the Drive System

**Service Interval:** Every 300 hours

1. Park the machine on a level surface, move the motion-control levers to the NEUTRAL-LOCK position, engage the parking brake, and lower the hopper.



2. Shut off the engine, and remove the key. Allow the engine to cool.
3. Lower the cushion and remove the fuel tank; refer to [Removing the Fuel Tank \(page 25\)](#).
4. Remove the 6 bolts (2 rear, 4 side) from the skid plate and remove the skid plate ([Figure 46](#)).

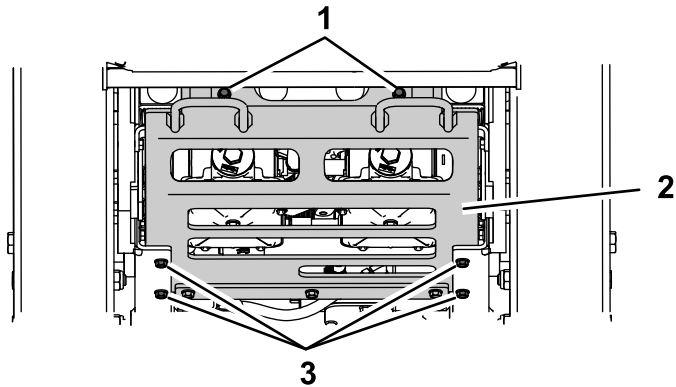
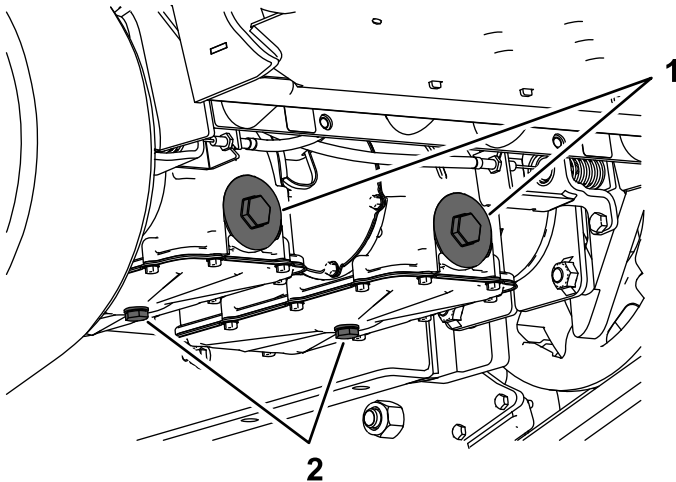

**Figure 46**

g203662

1. Rear bolt (2)
2. Skid plate
3. Side bolt (4)

5. Locate the drain plug in the bottom of each transmission, then place a drain pan under the plugs ([Figure 47](#)).



**Figure 47**

g203515

1. Hydraulic filter
2. Drain plug

6. Remove the drain plugs and allow the hydraulic fluid to fully drain from the machine.
7. Remove the hydraulic-filter cap and hydraulic filter from each transmission ([Figure 47](#)).
8. Install a new hydraulic filter with the spring side facing out and the hydraulic-filter cap for each transmission. Torque to 13 to 15 N·m (115 to 135 in-lb).
9. Install the drain plugs.

10. Loosen the vent plug in each transmission until loose ([Figure 48](#)).

**Note:** This allows air to escape the hydraulic system as you add hydraulic fluid.

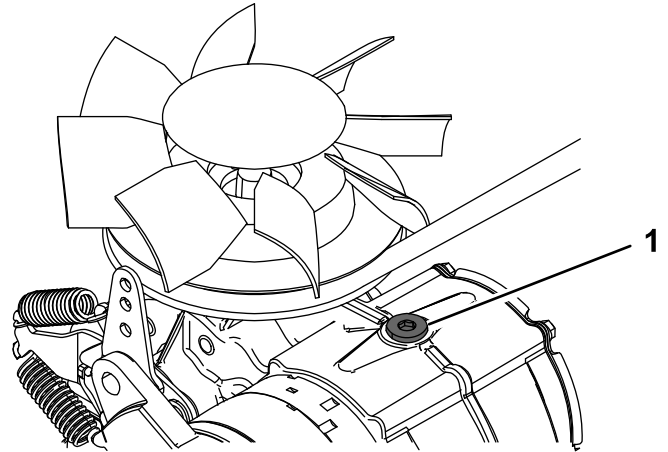

**Figure 48**

g203517

1. Vent plug

11. Slowly add approximately 6.2 L (208 fl oz) fluid to the expansion tank until it starts to come out of the vent plugs.

**Important:** Use the fluid specified in [Servicing the Hydraulic Drive System \(page 32\)](#) or equivalent. Other fluids could cause system damage.

**Important:** Monitor the level of fluid in the expansion tank so that you do not overfill it.

12. Tighten the vent plugs.
13. Add hydraulic fluid to the expansion tank until it reaches the fluid line ([Figure 44](#)).

**Important:** Do not overfill.

14. Install the expansion-tank cap.
15. Install the skid plate ([Figure 46](#)).
16. Install the fuel tank; refer to [Removing the Fuel Tank \(page 25\)](#).
17. Start the engine and let it run for about 2 minutes to purge air from the system.
18. Shut off the engine and check for leaks.

## Bleeding the Hydraulic Drive System

Bleed the traction hydraulic system whenever you perform maintenance on the hydrostatic transmission or add hydraulic fluid to the expansion tank.

1. Park the machine on a level surface, move the motion-control levers to the NEUTRAL-LOCK position, engage the parking brake, and lower the hopper.
2. Shut off the engine, and remove the key. Allow the engine to cool.
3. Check the hydraulic fluid level and add hydraulic fluid as necessary; refer to [Checking the Hydraulic-Fluid Level for the Drive System \(page 32\)](#).
4. Support the machine on jack stands, high enough to raise the tracks off the ground.
5. Start the machine. Slowly move the motion-control levers forward and reverse 5 to 6 times.
6. Check the hydraulic fluid level and add hydraulic fluid as necessary.
7. Repeat steps 5 and 6 as necessary until all the air is completely purged from the system.

**Note:** Purging is complete when you obtain normal forward and reverse speed.

8. Lower the machine and repeat the procedure with the tracks on the ground.

## Servicing the Hydraulic Lift System

### Checking the Hydraulic-Fluid Level for the Lift System

**Service Interval:** Before each use or daily

Reservoir-tank capacity: 1.4 L (1.5 US quarts)

Hydraulic-fluid type: Toro Premium All Season Hydraulic Fluid or Mobil® 424 Hydraulic Fluid

**Important:** Always use the correct hydraulic fluid. Unspecified fluids will damage the hydraulic system.

**Note:** Many hydraulic fluids are almost colorless, making it difficult to spot leaks. A red dye additive for the hydraulic system oil is available in 0.67 fl oz (20 ml) bottles. One bottle is sufficient for 4 to 6 gal (15 to 22 L) of hydraulic fluid. Order Part No. 44-2500 from your authorized Toro distributor.

1. Park the machine on a level surface, move the motion-control levers to the NEUTRAL-LOCK position, engage the parking brake, raise the hopper, and install the cylinder lock.
2. Shut off the machine and remove the key. Allow the machine to cool completely.
3. Remove the filler cap from the reservoir tank ([Figure 49](#)).

### **CAUTION**

The hydraulic breather/filler cap is designed to pressurize the reservoir to 34 kPa (5 psi).

Loosen the cap slowly to avoid injury whenever adding fluid or working on the hydraulic system. Use a wrench on the hex directly under the cap.

# Changing the Hydraulic Fluid for the Lift System

**Service Interval:** Every 300 hours

1. Park the machine on a level surface, move the motion-control levers to the NEUTRAL-LOCK position, engage the parking brake, raise the hopper, and install the cylinder lock.
2. Shut off the machine and remove the key. Allow the machine to cool completely.
3. Remove the filler cap from the reservoir tank (Figure 49).

## ⚠ CAUTION

The hydraulic breather/filler cap is designed to pressurize the reservoir to 34 kPa (5 psi).

Loosen the cap slowly to avoid injury whenever adding oil or working on the hydraulic system. Use a wrench on the hex directly under the cap.

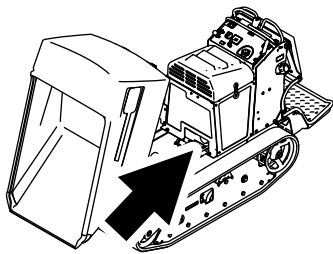

g185888

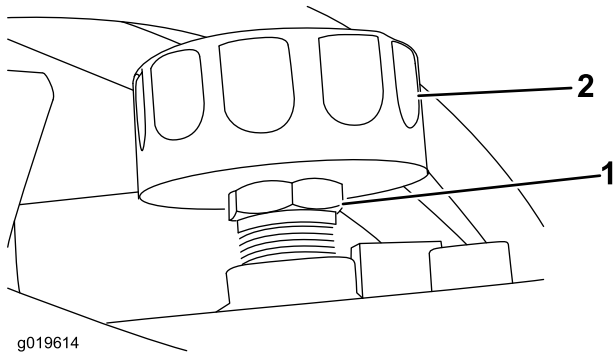

g019614

g019614

**Figure 49**

1. Hex
2. Filler cap

4. Look inside the tank to check the fluid level.

**Note:** If the machine is cool, the fluid should be at the COLD level; if the machine is hot, the fluid should be at the HOT level.

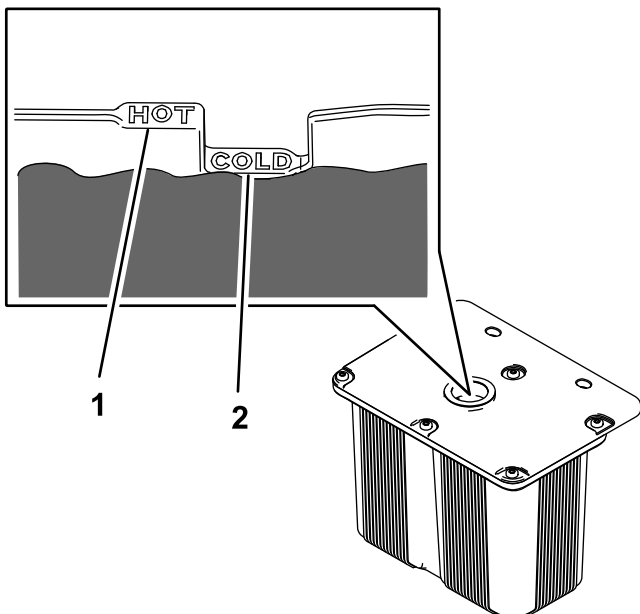

g189403

**Figure 50**

1. HOT level
2. COLD level

5. Fill the tank with hydraulic fluid only up to the COLD level.
6. Install the fill cap. Wipe up any spilled hydraulic fluid.
7. Remove the cylinder lock and lower the hopper.

4. Place a large drain pan under the fittings at the bottom of the reservoir tank.
5. Disconnect a hose fitting and allow the fluid to drain into the pan.
6. When finished, install and tighten the fitting.

**Note:** Dispose of the used fluid at a certified recycling center.

7. Fill the reservoir tank with approximately 2.2 L (74 fl oz) and install the filler cap.
8. Remove the cylinder lock.
9. Start the engine. Raise and lower the hopper 3 times to fill the cylinder and hoses with fluid.
10. Raise the hopper and install the cylinder lock.
11. Shut off the engine.
12. Add 0.60 L (20 fl oz) of hydraulic fluid and install the filler cap.

**Note:** The fluid level should be at the Cold fill line. Do not fill past this line.

13. Remove the cylinder lock.
14. Start the engine. Raise and lower the hopper several times to remove air from the system.

# Replacing the Hydraulic Filter for the Lift System

Service Interval: Every 300 hours

**Important:** Do not substitute an automotive oil filter or severe hydraulic system damage may result.

1. Park the machine on a level surface, move the motion-control levers to the NEUTRAL-LOCK position, engage the parking brake, raise the hopper, and install the cylinder lock.
2. Shut off the engine, and remove the key. Allow the engine to cool.
3. Replace the filter as shown in [Figure 51](#).

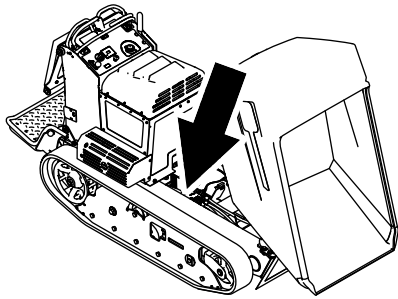

g186042

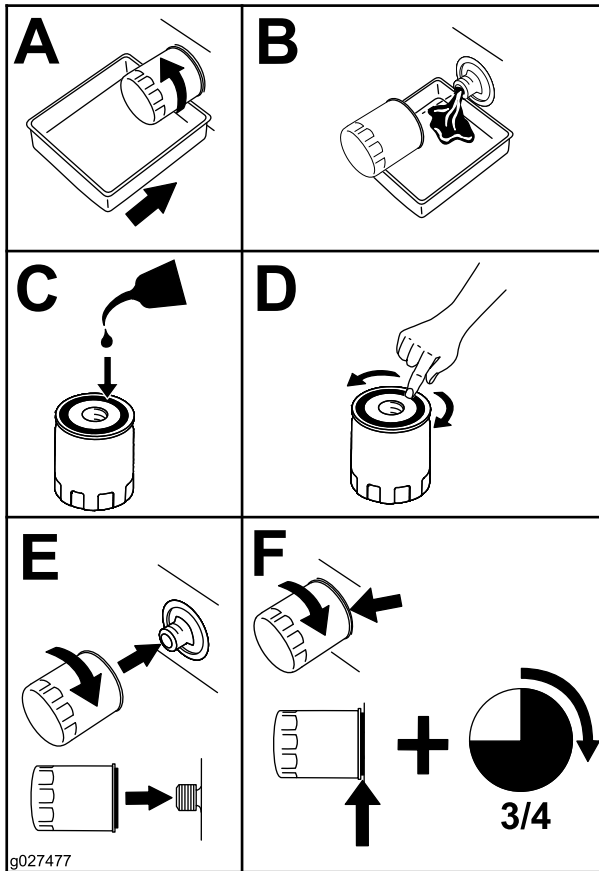

g027477

g027477

Figure 51

5. Shut off the engine and check for leaks.
6. Check the fluid level in the reservoir tank, refer to [Checking the Hydraulic-Fluid Level for the Lift System \(page 34\)](#).  
**Note:** Do not overfill the reservoir tank.
7. Remove the cylinder lock and lower the hopper.

# Checking the Hydraulic Lines

**Service Interval:** Every 40 hours—Check the hydraulic lines for leaks, loose fittings, kinked lines, loose mounting supports, wear, and deterioration. (Make necessary repairs before operating.)

## ⚠ WARNING

Hydraulic fluid escaping under pressure can penetrate skin and cause injury. Fluid injected into the skin must be surgically removed within a few hours by a doctor familiar with this form of injury; otherwise, gangrene may result.

- Keep your body and hands away from pinhole leaks or nozzles that eject high-pressure hydraulic fluid.
- Use cardboard or paper to find hydraulic leaks; never use your hands.

4. Start the engine and let it run for about 2 minutes to purge air from the system.

# Cleaning

## Removing Debris from the Machine

**Service Interval:** Before each use or daily

Every 100 hours

1. Park the machine on a level surface, move the motion-control levers to the NEUTRAL-LOCK position, engage the parking brake, and lower the hopper.
2. Shut off the engine, and remove the key. Allow the engine to cool.
3. Clean the inside of the hopper using a hose.
4. Clean any debris from under the hopper.
5. Wipe away debris from the air cleaner.
6. Clean any debris buildup on the engine and in the transmission with a brush or blower.

***Important:*** It is preferable to blow dirt out, rather than washing it out. If you use water, keep it away from electrical parts and hydraulic valves. Do not use a high-pressure washer. High-pressure washing can damage the electrical system and hydraulic valves or deplete grease.

# Storage

1. Engage the parking brake, shut off the engine, and remove the key.
2. Remove dirt and grime from the external parts of the entire machine, especially the engine. Clean dirt and chaff from the outside of the engine cylinder head fins and blower housing.
3. Service the air cleaner; refer to [Servicing the Air Cleaner \(page 19\)](#).
4. Grease the machine; refer to [Greasing the Machine \(page 19\)](#).
5. Change the engine crankcase oil; refer to [Changing the Engine Oil and Filter \(page 21\)](#).
6. For storage over 30 days, prepare the machine as follows:
  - A. Add a petroleum-based fuel stabilizer/conditioner to the fuel in the tank. **Do not use an alcohol-based stabilizer (ethanol or methanol).**
  - B. Run the engine to distribute conditioned fuel through the fuel system for 5 minutes.
  - C. Shut off the engine, allow it to cool, and drain the fuel tank using a pump-type syphon.
  - D. Start the engine and run it until it shuts off.
  - E. Choke the engine.
  - F. Start and run the engine until it does not start again.
  - G. Dispose of fuel properly. Recycle as per local codes.

**Important:** Do not store fuel containing stabilizer/conditioner longer than the duration recommended by the fuel-stabilizer manufacturer.
7. Remove the spark plugs and check the condition of them; refer to [Checking the Spark Plug \(page 23\)](#).
8. Prepare the engine as follows:
  - A. With the spark plugs removed from the engine, pour 2 tablespoons of engine oil into the spark plug holes.
  - B. Place a rag over the spark plug holes to catch any oil spray, then turn the key to crank the engine and distribute the oil inside the cylinder.
  - C. Install the spark plugs.

**Note:** Do not install the wire on the spark plugs.
9. Check and tighten all bolts, nuts, and screws. Repair or replace any part that is damaged.
10. Paint all scratched or bare metal surfaces. Paint is available from your Authorized Service Dealer.
11. Store the machine in a clean, dry garage or storage area.
12. Cover the machine to protect it and keep it clean.

**Notes:**

# California Proposition 65 Warning Information

## What is this warning?

You may see a product for sale that has a warning label like the following:



**WARNING: Cancer and Reproductive Harm—**[www.p65Warnings.ca.gov](http://www.p65Warnings.ca.gov).

## What is Prop 65?

Prop 65 applies to any company operating in California, selling products in California, or manufacturing products that may be sold in or brought into California. It mandates that the Governor of California maintain and publish a list of chemicals known to cause cancer, birth defects, and/or other reproductive harm. The list, which is updated annually, includes hundreds of chemicals found in many everyday items. The purpose of Prop 65 is to inform the public about exposure to these chemicals.

Prop 65 does not ban the sale of products containing these chemicals but instead requires warnings on any product, product packaging, or literature with the product. Moreover, a Prop 65 warning does not mean that a product is in violation of any product safety standards or requirements. In fact, the California government has clarified that a Prop 65 warning "is not the same as a regulatory decision that a product is 'safe' or 'unsafe.'" Many of these chemicals have been used in everyday products for years without documented harm. For more information, go to <https://oag.ca.gov/prop65/faqs-view-all>.

A Prop 65 warning means that a company has either (1) evaluated the exposure and has concluded that it exceeds the "no significant risk level"; or (2) has chosen to provide a warning based on its understanding about the presence of a listed chemical without attempting to evaluate the exposure.

## Does this law apply everywhere?

Prop 65 warnings are required under California law only. These warnings are seen throughout California in a wide range of settings, including but not limited to restaurants, grocery stores, hotels, schools, and hospitals, and on a wide variety of products. Additionally, some online and mail order retailers provide Prop 65 warnings on their websites or in catalogs.

## How do the California warnings compare to federal limits?

Prop 65 standards are often more stringent than federal and international standards. There are various substances that require a Prop 65 warning at levels that are far lower than federal action limits. For example, the Prop 65 standard for warnings for lead is 0.5 µg/day, which is well below the federal and international standards.

## Why don't all similar products carry the warning?

- Products sold in California require Prop 65 labelling while similar products sold elsewhere do not.
- A company involved in a Prop 65 lawsuit reaching a settlement may be required to use Prop 65 warnings for its products, but other companies making similar products may have no such requirement.
- The enforcement of Prop 65 is inconsistent.
- Companies may elect not to provide warnings because they conclude that they are not required to do so under Prop 65; a lack of warnings for a product does not mean that the product is free of listed chemicals at similar levels.

## Why does Toro include this warning?

Toro has chosen to provide consumers with as much information as possible so that they can make informed decisions about the products they buy and use. Toro provides warnings in certain cases based on its knowledge of the presence of one or more listed chemicals without evaluating the level of exposure, as not all the listed chemicals provide exposure limit requirements. While the exposure from Toro products may be negligible or well within the "no significant risk" range, out of an abundance of caution, Toro has elected to provide the Prop 65 warnings. Moreover, if Toro does not provide these warnings, it could be sued by the State of California or by private parties seeking to enforce Prop 65 and subject to substantial penalties.