



Count on it.

Operator's Manual

Blower Kit

GrandStand® Multi Force Mower

Model No. 78593—Serial No. 402860000 and Up



⚠ WARNING

**CALIFORNIA
Proposition 65 Warning**

Use of this product may cause exposure to chemicals known to the State of California to cause cancer, birth defects, or other reproductive harm.

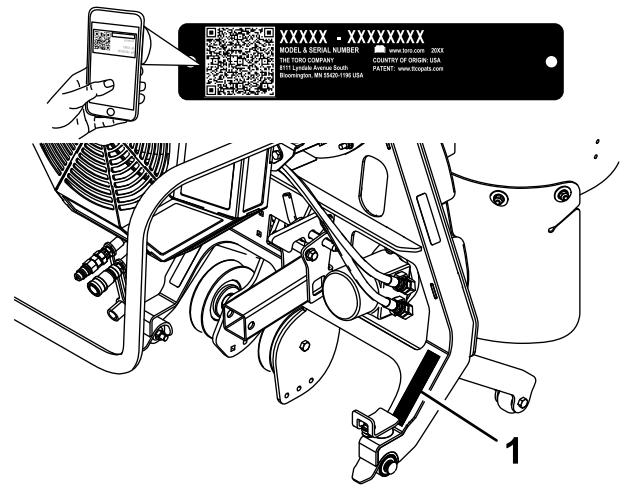

g246145

Figure 1

1. Location of the model and serial numbers

Model No. _____
Serial No. _____

Introduction

This blower is intended to be used by professional, hired operators. It is primarily designed to use wind power to quickly clear large areas of unwanted debris on well-maintained lawns, parks, golf courses, sports fields, and on commercial grounds.

Read this information carefully to learn how to operate and maintain your product properly and to avoid injury and product damage. You are responsible for operating the product properly and safely.

You may contact Toro directly at www.Toro.com for product safety and operation training materials, accessory information, help finding a dealer, or to register your product.

Whenever you need service, genuine Toro parts, or additional information, contact an Authorized Service Dealer or Toro Customer Service and have the model and serial numbers of your product ready. [Figure 1](#) identifies the location of the model and serial numbers on the product. Write the numbers in the space provided.

Important: With your mobile device, you can scan the QR code on the serial number decal (if equipped) to access warranty, parts, and other product information.

This manual identifies potential hazards and has safety messages identified by the safety-alert symbol ([Figure 2](#)), which signals a hazard that may cause serious injury or death if you do not follow the recommended precautions.



g000502

Figure 2

1. Safety-alert symbol

This manual uses 2 words to highlight information. **Important** calls attention to special mechanical information and **Note** emphasizes general information worthy of special attention.

Contents

Safety	3
General Safety	3
Safety and Instructional Decals	4
Setup	5
1 Preparing the Machine	5
2 Installing the Wheel Weight Kit (Optional)	5
3 Positioning the Caster Wheels	5
4 Removing the Right Fan Guard	6
5 Installing the Blower	7
Operation	10
Operation Safety	10
Operating the Blower	10
Using the Kickstand	11
Removing the Blower	13
Operating Tips	15
Maintenance	16
Maintenance Safety	16
Checking the Belts	16
Replacing the Blower Belt	16
Replacing the Clutch Belt	17
Checking the Hydraulic Hoses	17
Removing Debris from the Machine	17

Safety

General Safety

This product is capable of throwing objects. Always follow all safety instructions to avoid serious personal injury.

Using this product for purposes other than its intended use could prove dangerous to you and bystanders.

- Read and understand the contents of this *Operator's Manual* before starting the engine.
- Use your full attention while operating the machine. Do not engage in any activity that causes distractions; otherwise, injury or property damage may occur.
- Do not put your hands or feet near moving components of the machine.
- Do not operate the machine without all guards and other safety protective devices in place and working on the machine.
- Keep clear of any discharge opening. Keep bystanders and pets a safe distance away from the machine.
- Keep children out of the operating area. Never allow children to operate the machine.
- Stop the machine, shut off the engine, and remove the key before servicing, fueling, or unclogging the machine.

Improperly using or maintaining this machine can result in injury. To reduce the potential for injury, comply with these safety instructions and always pay attention to the safety-alert symbol , which means Caution, Warning, or Danger—personal safety instruction. Failure to comply with these instructions may result in personal injury or death.

You can find additional safety information where needed throughout this *Operator's Manual*.

Safety and Instructional Decals



Safety decals and instructions are easily visible to the operator and are located near any area of potential danger. Replace any decal that is damaged or missing.



decal119-0217

119-0217

1. Warning—shut off the engine; stay away from moving parts; keep all guards and shields in place.

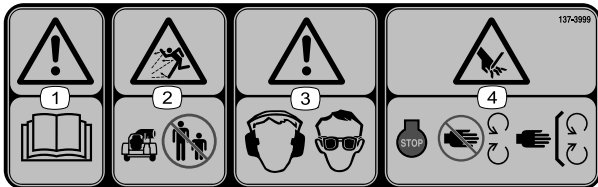

decal137-3999

137-3999

- | | |
|---|---|
| <ol style="list-style-type: none"> 1. Warning—read the <i>Operator's Manual</i>. 2. Thrown object hazard—keep bystanders away from the machine. | <ol style="list-style-type: none"> 3. Warning—wear hearing and eye protection. 4. Cutting/dismemberment hazard of hands—shut off the engine; keep hands away from moving parts; keep all guards and shields in place. |
|---|---|

Setup

Loose Parts

Use the chart below to verify that all parts have been shipped.

Procedure	Description	Qty.	Use
1	No parts required	–	Prepare the machine.
2	Wheel Weight Kit (sold separately)	1	Install the Wheel Weight Kit (optional).
3	No parts required	–	Position the caster wheels.
4	No parts required	–	Remove the fan guard.
5	Blower assembly Bushing assembly Carriage bolt (3/8 x 2-1/4 inches) Locknut (3/8 inch) Receiver hitch Heat shield Bumper Thread-forming screw (1/4 x 1/2 inch) Stop bracket Carriage bolt (3/8 x 1 inch) Nut (3/8 inch) Washer Spacer Thread-forming screw (1/4 x 1-1/4 inch)	1 2 2 2 1 1 2 2 1 1 1 1 1 1 1	Install the blower.

Important: Install the Low Flow Hydraulics Kit on your machine before installing this kit.

1

Preparing the Machine

No Parts Required

Procedure

1. Park the machine on a level surface.
2. Lower the A-frame.
3. Disengage the PTO, engage the parking brake, and move the motion-control levers outward to the NEUTRAL-LOCK position.
4. Shut off the engine and remove the key.

2

Installing the Wheel Weight Kit (Optional)

Parts needed for this procedure:

1	Wheel Weight Kit (sold separately)
---	------------------------------------

Procedure

Installing wheel weights can improve traction on the machine when using the blower; refer to the *Installation Instructions* for the Wheel Weight Kit.

3

Positioning the Caster Wheels

No Parts Required

Procedure

For both casters, remove the nut and bolt, move the caster to the front position, and install the nut and bolt (Figure 3). Torque to 91 to 113 N·m (67 to 83 ft-lb).

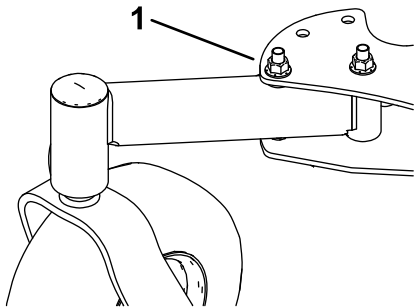

Figure 3

g230693

-
1. Nut and bolt

4

Removing the Right Fan Guard

No Parts Required

Procedure

1. Remove the fuel tank; refer to the *Operator's Manual* for the machine.
2. Remove and retain the 2 bolts, 2 nuts, and the right fan guard (Figure 4).

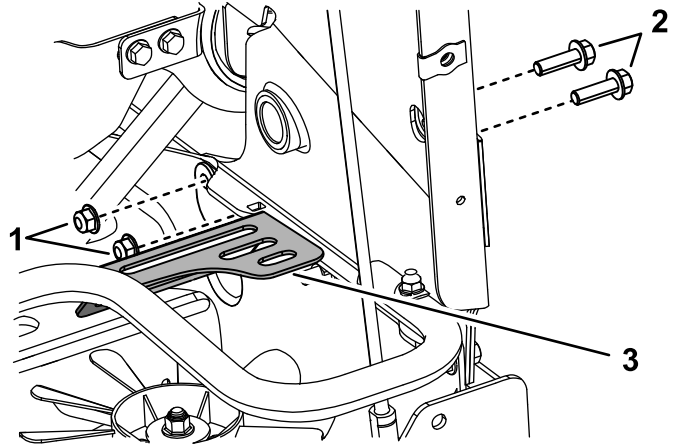

Figure 4

g246823

-
1. Nut (3/8 inch) 3. Right fan guard
2. Bolt (3/8 x 1-1/4 inch)

-
3. Install the bolts and nuts you removed and torque to 41 to 49 N·m (30 to 36 ft-lb).
 4. Install the fuel tank.

5

Installing the Blower

Parts needed for this procedure:

1	Blower assembly
2	Bushing assembly
2	Carriage bolt (3/8 x 2-1/4 inches)
2	Locknut (3/8 inch)
1	Receiver hitch
1	Heat shield
2	Bumper
2	Thread-forming screw (1/4 x 1/2 inch)
1	Stop bracket
1	Carriage bolt (3/8 x 1 inch)
1	Nut (3/8 inch)
1	Washer
1	Spacer
1	Thread-forming screw (1/4 x 1-1/4 inch)

Procedure

1. Remove the air-cleaner cover and filter; refer to the *Operator's Manual* for the machine.
2. Install the 2 bumpers on the heat shield (Figure 5).

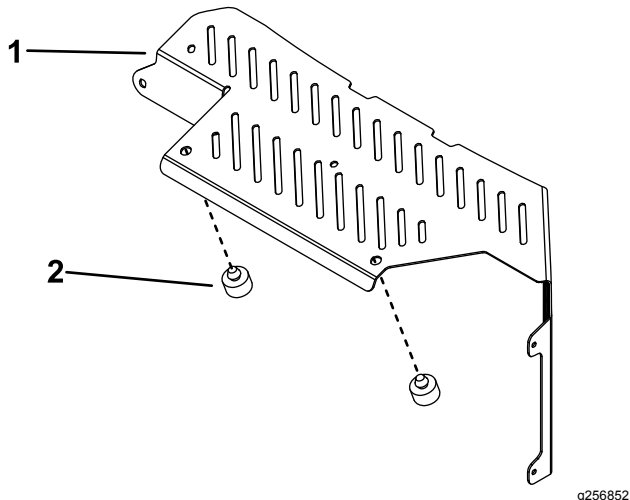

Figure 5

1. Heat shield
2. Bumper

3. Remove the top carriage bolt and nut securing the muffler guard to the machine (Figure 6).

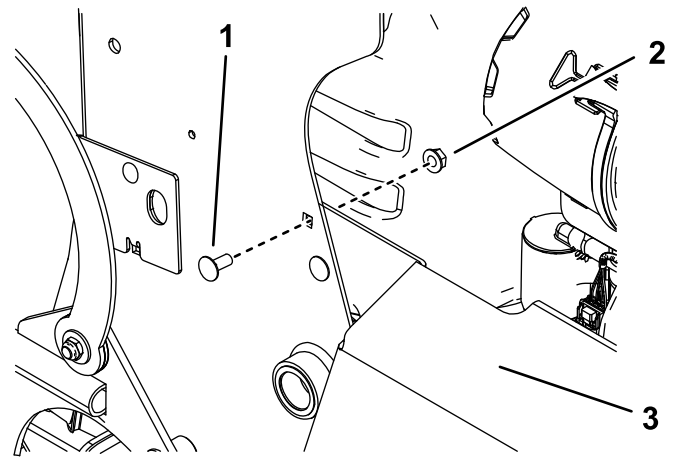

Figure 6

1. Carriage bolt
2. Nut
3. Muffler guard

4. **Loosely** install the heat shield over the muffler guard, with the tabs inside the muffler guard and to the inside of the console tower, using the 2 thread-forming bolts (1/4 x 1/2 inch) and the carriage bolt and nut you removed previously (Figure 7).

Important: To minimize debris buildup on the muffler, install the heat shield on the machine when using the blower.

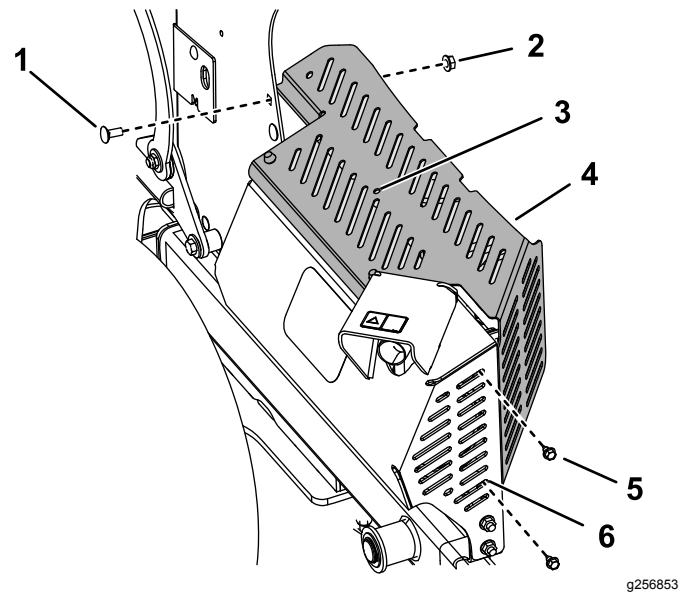

Figure 7

1. Carriage bolt
2. Nut
3. Drill here.
4. Heat shield
5. Thread-forming bolt—1/4 x 1/2 inch (2)
6. Tab (inside muffler guard)

- Using the center hole in the heat shield as a template, drill a hole (7/32 inch) into the muffler guard (Figure 7).
- Use the thread-forming bolt (1/4 x 1-1/4 inch) and washer to install the spacer between the heat shield and muffler guard (Figure 8).

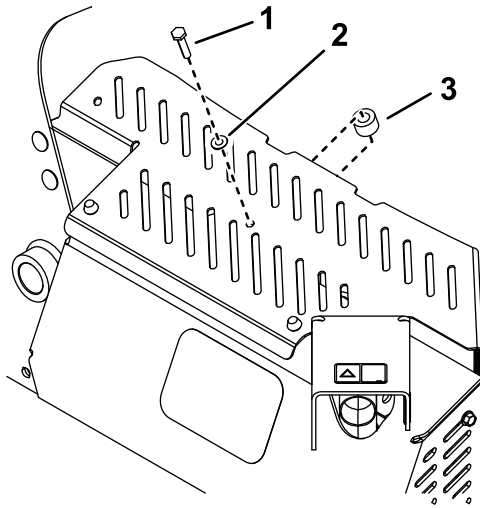

Figure 8

- Thread-forming bolt (1/4 x 1-1/4)
- Washer
- Spacer

- Torque the 3 thread-forming bolts to 4.5 N·m (40 in-lb).

Note: Do not torque the carriage bolt at this time.

- Install the air-cleaner filter and cover.

- Use a carriage bolt (3/8 x 2-1/4 inches) and nut (3/8 inch) to install the bushing assemblies to the machine (Figure 9). Torque the bolt to 37 to 45 N·m (27 to 33 ft-lb).

Note: The rubber flange of the bushing should face toward the inside of the machine as shown in Figure 9.

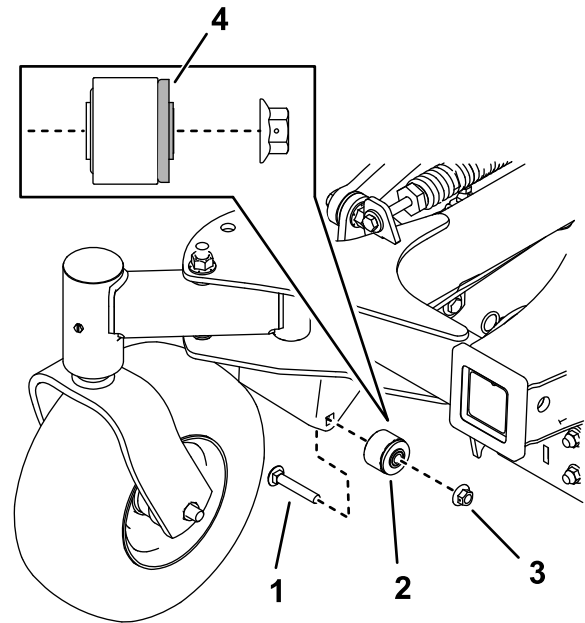

Figure 9

- Carriage bolt (3/8 x 2-1/4 inches)
- Bushing assembly
- Nut (3/8 inch)
- Rubber flange

- Use a carriage bolt (3/8 x 1 inch) and a locknut (3/8 inch) to install the stop bracket to the right side of the machine (Figure 10). Torque the bolt to 37 to 45 N·m (27 to 33 ft-lb).

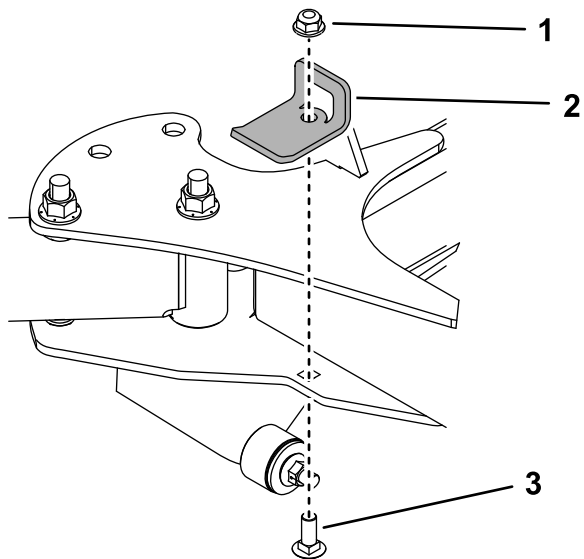

Figure 10

g250341

- Locknut (3/8 inch)
- Stop bracket
- Carriage bolt (3/8 x 1 inch)

- Remove the hitch pin and cotter pin from the A-frame and use it to install the hitch receiver (Figure 11). Ensure that the pin locks the A-frame to the cross tube.

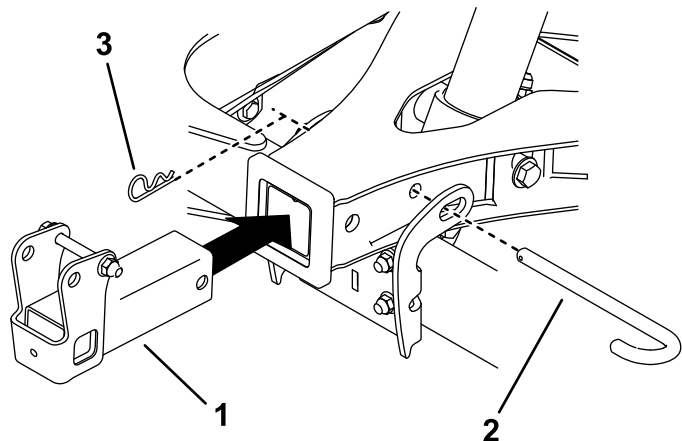

Figure 11

g230752

- Hitch receiver
- Hitch pin
- Cotter pin

- Move the blower in front of the machine and lay the belt underneath the machine so that it is lined up with the clutch (Figure 12).

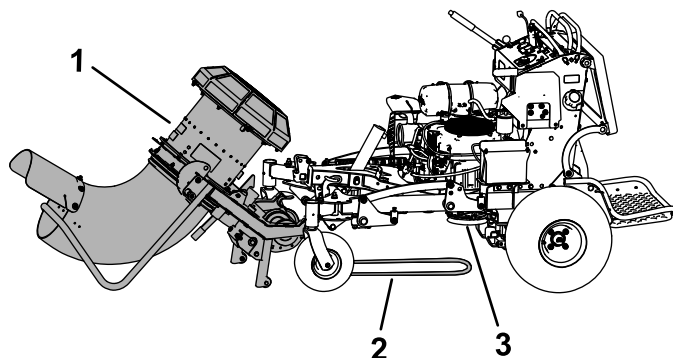

Figure 12

g230767

- Blower assembly
- Belt
- Clutch

- Place the blower assembly forks onto the bushing assemblies (Figure 13).

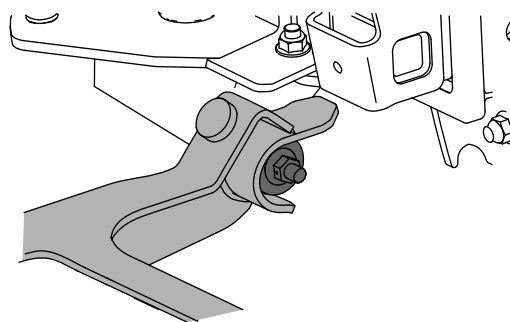

Figure 13

g250511

- Install the belt onto the clutch. Verify that the belt is still routed on the blower pulleys and is seated properly in the pulley grooves.

Note: You can use a drive ratchet (1/2 inch) to move the left idler pulley (Figure 14).

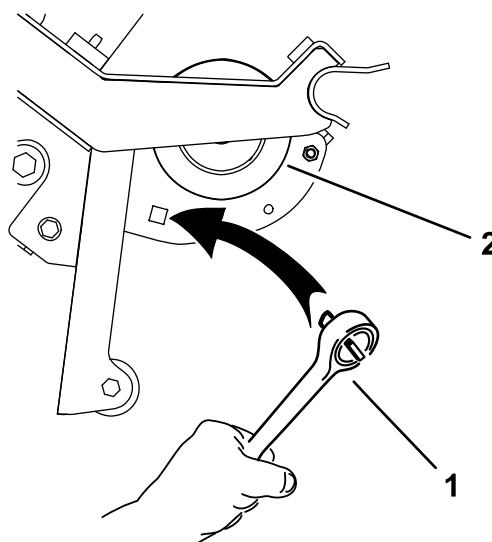

Figure 14

g231579

- Drive ratchet
- Pulley

15. Raise the blower as described in [Raising the Blower \(page 12\)](#).
16. Connect the hydraulic hoses to the quick-disconnect couplings on the Low Flow Hydraulics Kit.

⚠ WARNING

Hydraulic fluid escaping under pressure can penetrate skin and cause injury. Fluid injected into the skin must be surgically removed within a few hours by a doctor familiar with this form of injury; otherwise, gangrene may result.

- **Ensure that all hydraulic-fluid hoses and lines are in good condition and all hydraulic connections and fittings are tight before applying pressure to the hydraulic system.**
- **Keep your body and hands away from pinhole leaks or nozzles that eject high-pressure hydraulic fluid.**
- **Use cardboard or paper to find hydraulic leaks; never use your hands.**

Operation

Operation Safety

- The machine exceeds noise levels of 85 dB(A) at the operator's position. Use hearing protection for prolonged exposure to reduce the potential of permanent hearing damage.
- Wear appropriate clothing including eye protection; long pants; substantial, slip-resistant footwear; and hearing protection. Tie back long hair and do not wear loose clothing or loose jewelry.
- Stay away from the nozzle opening when the machine is operating. Keep all bystanders away from the nozzle opening and don't direct discharge toward bystanders.
- When a person or pet appears unexpectedly in or near the operating area, stop operation. Careless operation, combined with terrain angles, ricochets, or improperly positioned guards can lead to thrown object injuries. Do not resume operation until the area is cleared of people and pets.
- Shut off the engine, remove the key, wait for all movement to stop, and allow the machine to cool before adjusting, cleaning, storing, or repairing it.

Operating the Blower

Important: Do not operate the blower without the heat shield installed on the machine.

To operate the blower, start the engine, move the motion-control levers to the center, unlocked position, move the throttle lever between half and full throttle, and engage the PTO ([Figure 15](#)).

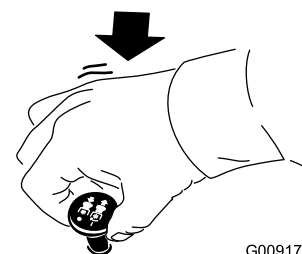

G009174

g009174

Figure 15

Use the right switch for the low flow kit to rotate the nozzle to the desired direction ([Figure 16](#)), and use the throttle lever to adjust the blower speed.

Note: If you would like to change the direction the nozzle rotates when you move the switch a particular direction, remove the quick-disconnect couplings from the Low-Flow Hydraulics Kit hoses and install them on the opposite hoses.

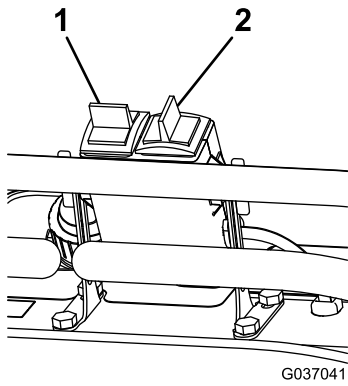

Figure 16

1. Not used with this kit 2. Rotate the blower nozzle.

Ensure to clean debris from the machine regularly.

⚠ WARNING

Discharged air has considerable force and could cause injury or loss of footing.

- Stay away from the nozzle opening when the machine is operating.
- Keep bystanders away from the nozzle opening when the machine is operating.

Using the Kickstand

Lowering the Blower

1. Rotate the blower nozzle so that it points upward.
2. Park the machine on a level surface, disengage the PTO, move the motion-control levers to the NEUTRAL-LOCK position, and engage the parking brake.
3. Shut off the engine, remove the key, and wait for all moving parts to stop before leaving the operating position.
4. Pull out the kickstand locking pins on both sides of the machine, rotate them 90 degrees so that they are disengaged, and rotate the kickstand away from the machine (Figure 17). Engage the pins and ensure that they snap into position.

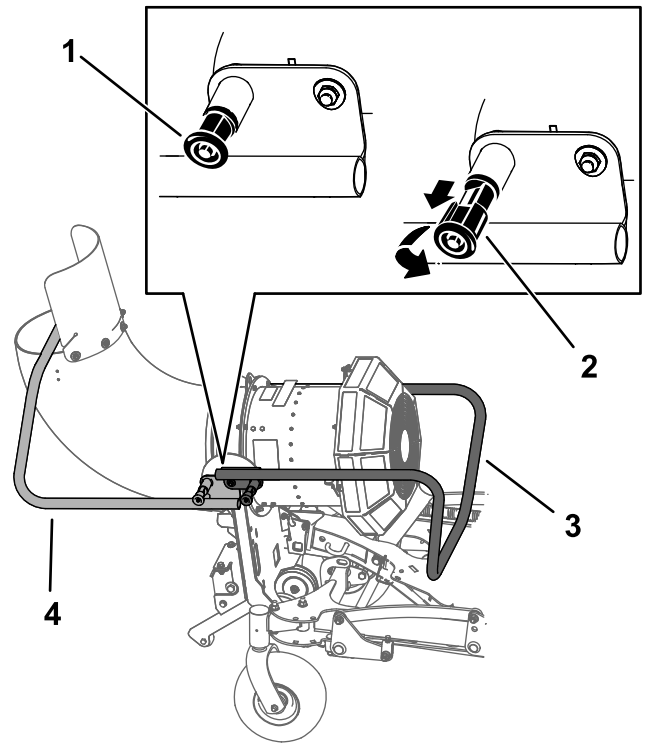

Figure 17

1. Kickstand locking pin in the engaged position
2. Kickstand locking pin in the disengaged position
3. Kickstand in the blower operating position
4. Kickstand in the blower storage position

5. Remove the hitch pin and hairpin cotter securing the blower assembly to the hitch receiver (Figure 18).

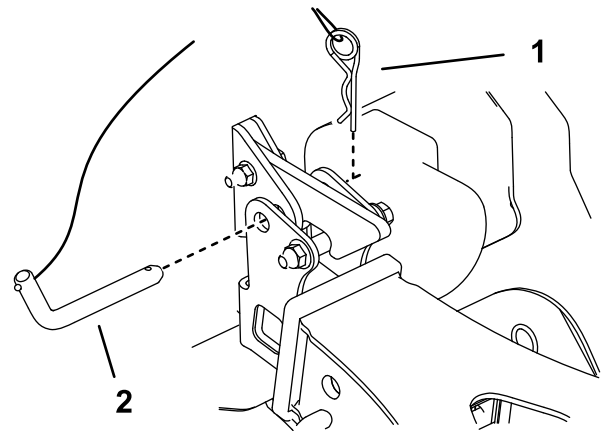

Figure 18

1. Hairpin cotter
2. Hitch pin

6. Hold the kickstand and push the release lever down. Slowly lower the kickstand to the ground.

Note: Once the lever disengages the hitch pin, the blower rotates down.

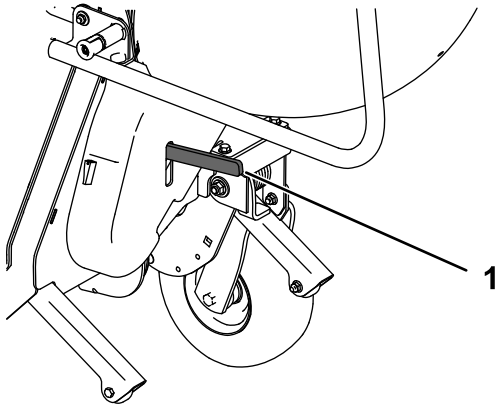

Figure 19

g230858

1. Release lever

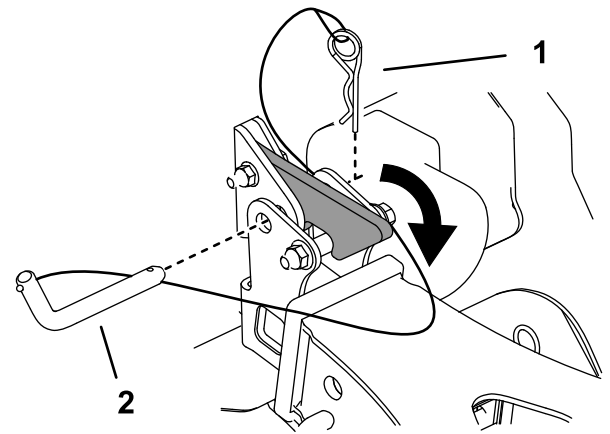

Figure 21

g230770

1. Hairpin cotter
2. Hitch pin

Raising the Blower

1. Raise the blower so that it latches on the hitch receiver (Figure 20 and Figure 21).

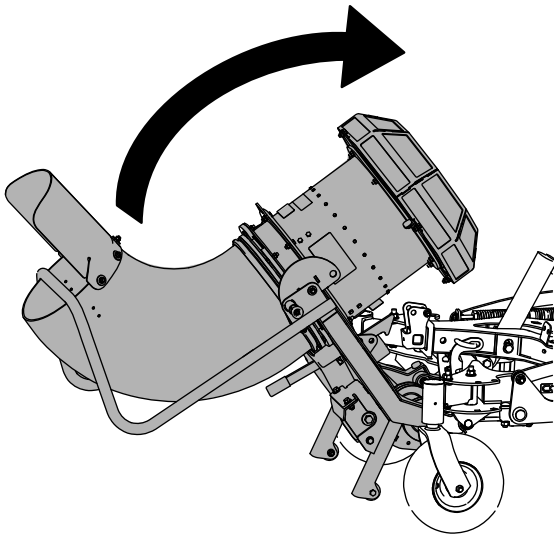

Figure 20

g230769

2. Secure the assembly to the hitch receiver using the hitch pin and hairpin cotter attached to the receiver (Figure 21).
3. Pull out the kickstand locking pins on both sides of the machine, rotate them 90 degrees so that they are disengaged, and raise the kickstand (Figure 22). Engage the knobs and ensure that the pins snap into position.

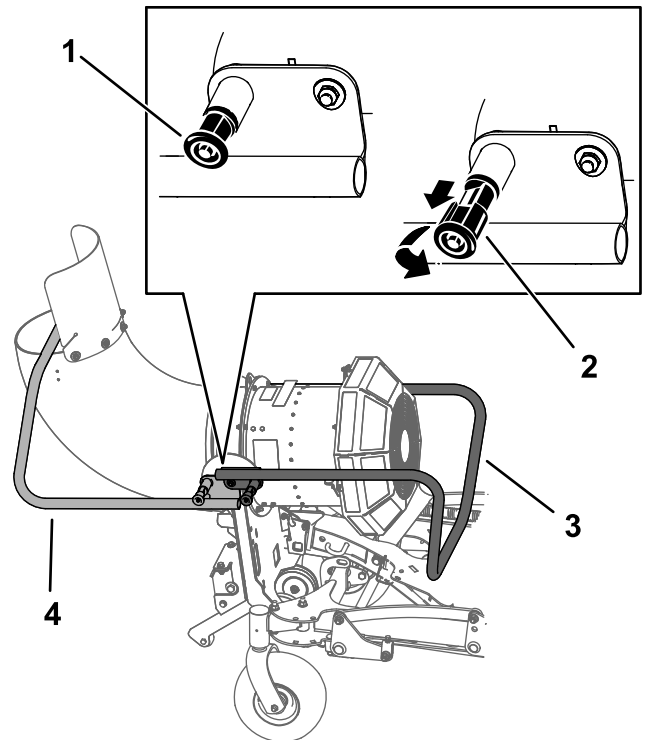

Figure 22

g230843

1. Kickstand locking pin in the engaged position
2. Kickstand locking pin in the disengaged position
3. Kickstand in the blower operating position
4. Kickstand in the blower storage position

Removing the Blower

1. Park the machine on a level surface, disengage the PTO, engage the parking brake, and move the motion-control levers outward to the NEUTRAL-LOCK position.
2. Shut off the engine and remove the key.
3. Disconnect the blower hydraulic hoses from the quick-disconnect couplings on the Low Flow Kit.
4. Lower the blower; refer to [Lowering the Blower \(page 11\)](#).
5. Remove the belt from the clutch.

Note: If needed, use a drive ratchet (1/2 inch) to move the left idler pulley ([Figure 23](#)).

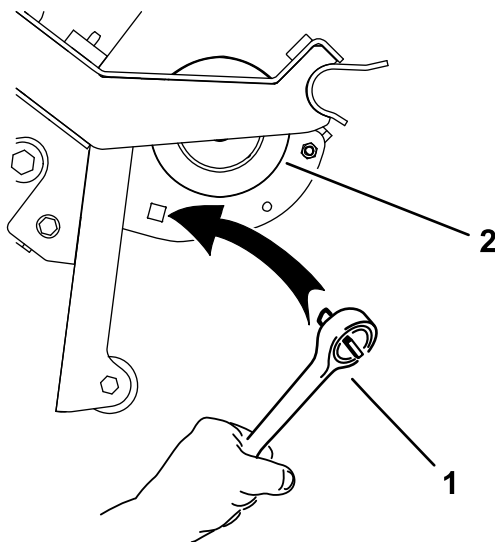

Figure 23

g231579

1. Drive ratchet
2. Pulley

6. Lift the blower assembly off the bushing assemblies on the machine.

7. Remove the hitch pin, cotter pin, and hitch receiver from the A-frame. Install the hitch pin and cotter pin to secure the A-frame ([Figure 24](#)).

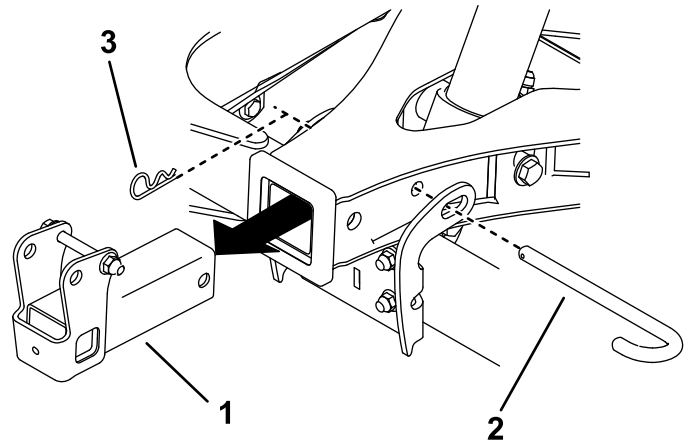

Figure 24

g246845

1. Hitch receiver
2. Hitch pin
3. Cotter pin

8. Remove the stop brackets ([Figure 25](#)).

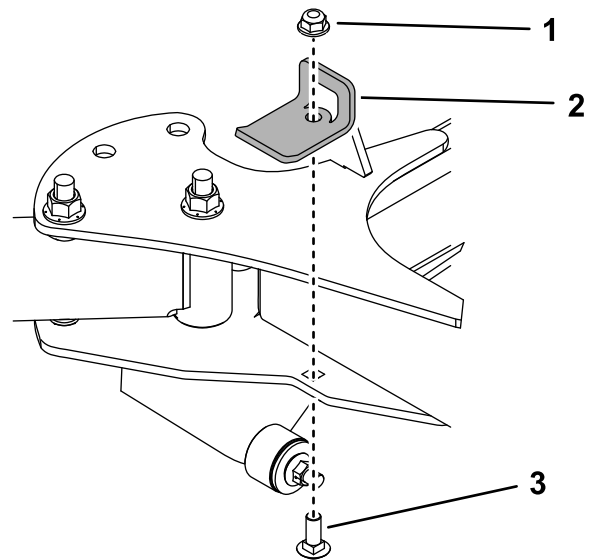

Figure 25

g250341

1. Locknut (3/8 inch)
2. Stop bracket
3. Carriage bolt (3/8 x 1 inch)

9. Remove both bushing assemblies ([Figure 26](#)).

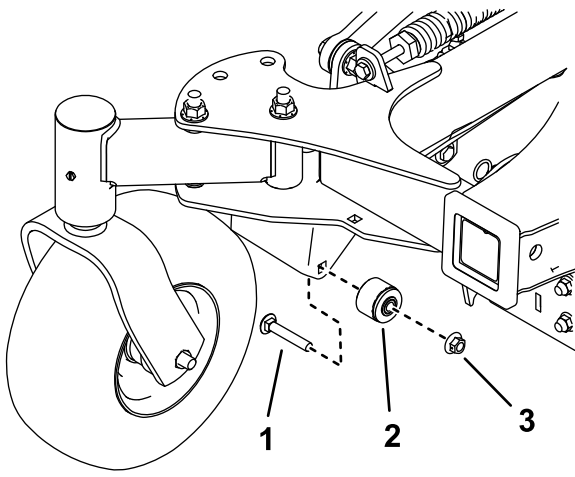

Figure 26

g230751

- 1. Bolt
- 2. Bushing assembly
- 3. Nut

10. Use the fasteners to store the bushing assemblies on the left side of the blower frame (Figure 27).

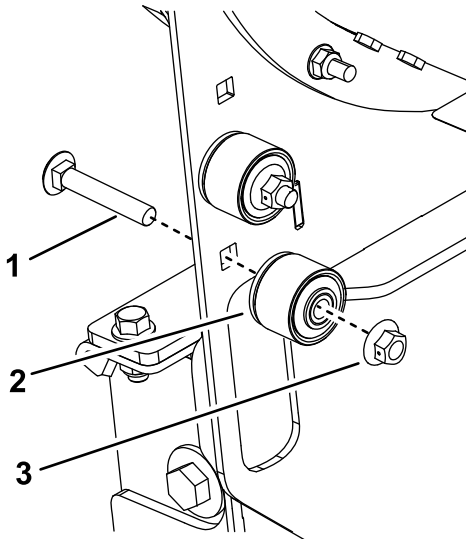

Figure 27

g246867

- 1. Bolt
- 2. Bushing assembly
- 3. Nut

11. Remove the spacer

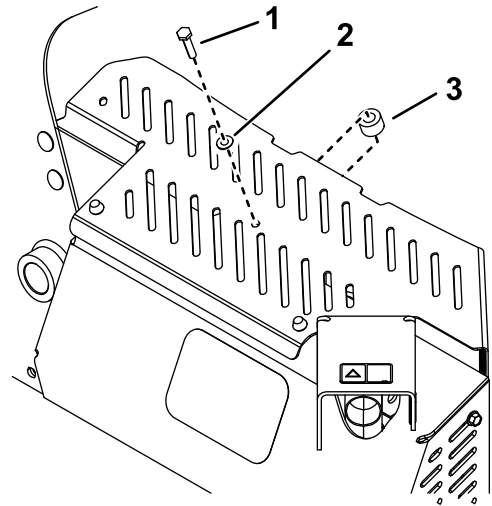

Figure 28

g256854

- 1. Thread-forming bolt (1/4 x 1-1/4)
- 2. Washer
- 3. Spacer

12. Remove the heat shield (Figure 29).

Important: Whenever you install the blower on another machine, also install the heat shield.

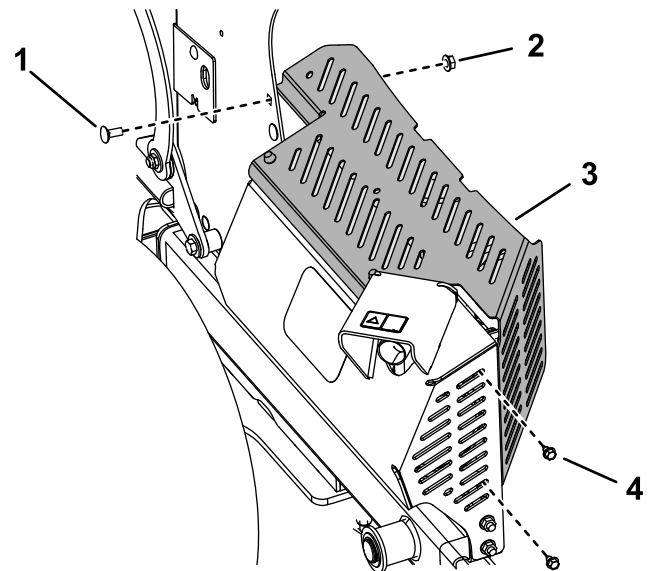

Figure 29

g256855

- 1. Carriage bolt
- 2. Nut
- 3. Heat shield
- 4. Thread-forming bolt (2)

13. Install the carriage bolt and nut to secure the muffler guard. Torque the bolt to 1978 to 2542 N-cm (175 to 225 in-lb).

14. Remove the fuel tank; refer to the *Operator's Manual* for the machine.

15. Remove the 2 bolts and 2 nuts from the right side of the machine and use them to install fan guard (Figure 30). Torque the bolts to 37 to 45 N·m (27 to 33 ft-lb).

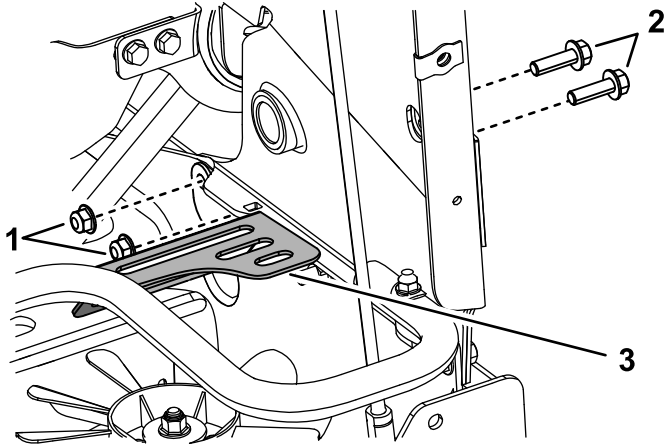

Figure 30

1. Nut (3/8 inch) 3. Fan guard
2. Bolt (3/8 x 1-1/4 inches)

Operating Tips

- Practice operating the blower. Blow the same direction the wind is blowing to prevent material from blowing back into the cleared area.
- Be aware of the blower nozzle direction and do not point it at anyone.
- Adjust the nozzle opening so that it blows under the debris.
- Use caution when blowing around newly planted sod as the force of the air could disrupt the grass.
- The nozzle outlet position affects the distance debris can be blown.
- When you rotate the nozzle, rotate it upward and around to prevent blowing debris back into the cleared area.

-
16. Install the fuel tank.

Maintenance

Maintenance Safety

- Park the machine on a level surface. Never allow untrained personnel to service the machine.
- Use jack stands to support the machine when required.
- Remove the key from the switch on the traction unit to prevent accidental starting of the engine when servicing, adjusting, or storing the machine.
- Perform only those maintenance instructions described in this manual. If the blower requires a major repair, contact an authorized Toro distributor.
- Ensure that the machine is in safe operating condition by keeping nuts, bolts, and screws tight.
- Keep your hands and feet away from moving parts. Do not make adjustments with the engine running.
- Keep all parts in good working condition and all hardware tightened. Replace all worn or damaged decals.
- To ensure optimum performance and continued safety certification of the machine, use only genuine Toro replacement parts and accessories. Replacement parts and accessories made by other manufacturers could be dangerous, and such use could void the product warranty.

Checking the Belts

Service Interval: Every 300 hours

Check the belts for cracks, frayed edges, burn marks, or any other damage. Replace damaged belts.

Replacing the Blower Belt

1. Park the machine on a level surface, disengage the PTO, and engage the parking brake.
2. Shut off the engine, remove the key, and wait for all moving parts to stop before leaving the operating position.
3. Remove the belt cover (Figure 31).

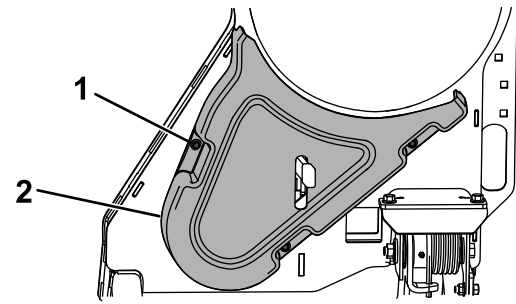

Figure 31

g246599

1. Bolt (3)
2. Belt cover

4. Loosen the nut on the top pulley and slide the pulley up to release tension on the belt (Figure 32).

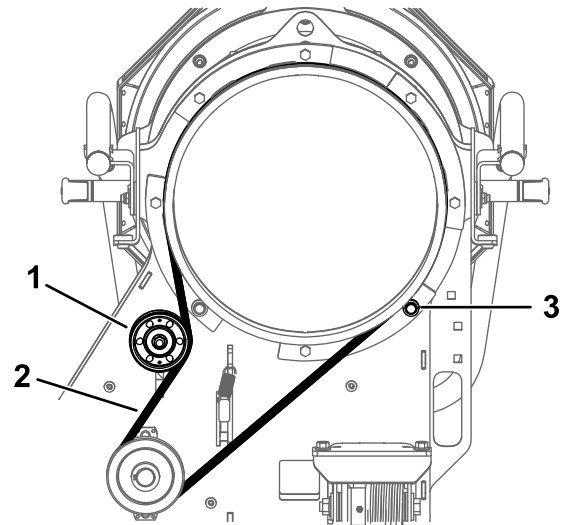

Figure 32

g250730

Blower nozzle not shown for clarity

1. Top pulley
2. Belt
3. Roller bearing

5. Remove the roller bearing (Figure 32).
6. Remove the belt and install a new belt (Figure 32).
7. Install the roller bearing (Figure 32)
8. Slide the top pulley down until the belt deflection is 5 mm (0.19 inch) at the center of the largest span and tighten the nut (Figure 32).

Replacing the Clutch Belt

1. Park the machine on a level surface, disengage the PTO, and engage the parking brake.
2. Shut off the engine, remove the key, and wait for all moving parts to stop before leaving the operating position.
3. Lower the blower.
4. Loosen the nozzle clamp and remove the nozzle.
5. Remove the belt from the machine clutch.

Note: You can use a drive ratchet (1/2 inch) to move the left idler pulley (Figure 14).

6. Remove the belt from the fan pulley (Figure 33).

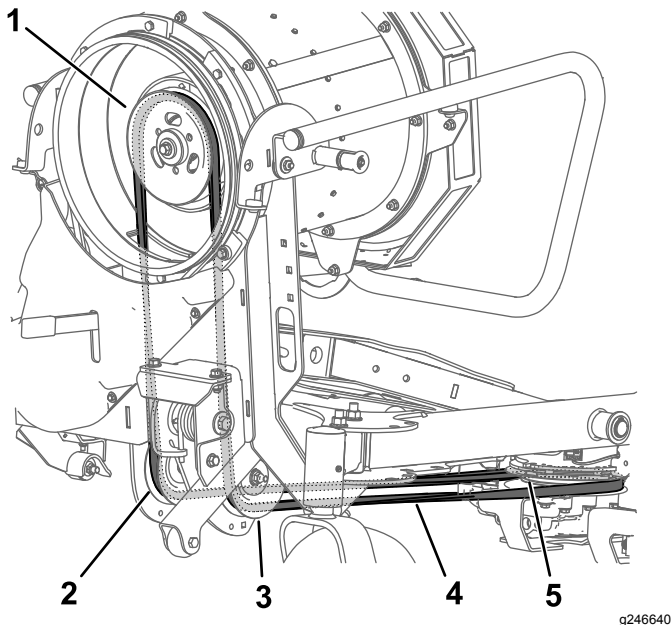

Figure 33

- | | |
|-----------------------|------------------|
| 1. Fan pulley | 4. Belt |
| 2. Right idler pulley | 5. Clutch pulley |
| 3. Left idler pulley | |

7. Route the belt down through the drive adapter assembly, around the idler pulleys, and around the clutch pulley (Figure 33). Ensure that the belt is seated properly in the pulley grooves.

Note: If needed, you may use a drive ratchet (1/2 inch) to move the left idler pulley (Figure 14).

Checking the Hydraulic Hoses

Service Interval: Every 100 hours

Check the hydraulic hoses for leaks, loose fittings, kinked lines, loose mounting supports, wear, weather, and chemical deterioration.

⚠ WARNING

Hydraulic fluid escaping under pressure can penetrate skin and cause injury. Fluid injected into the skin must be surgically removed within a few hours by a doctor familiar with this form of injury; otherwise, gangrene may result.

- Ensure that all hydraulic-fluid hoses and lines are in good condition and all hydraulic connections and fittings are tight before applying pressure to the hydraulic system.
- Keep your body and hands away from pinhole leaks or nozzles that eject high-pressure hydraulic fluid.
- Use cardboard or paper to find hydraulic leaks; never use your hands.

Removing Debris from the Machine

Service Interval: After each use

1. Park the machine on a level surface, disengage the PTO, and engage the parking brake.
2. Shut off the engine, remove the key, and wait for all moving parts to stop before leaving the operating position.
3. Clean debris from the drives, muffler, and engine after each use.

Notes:

Notes:



Count on it.