



**Count on it.**

**Operator's Manual**

# Stand-On Spreader/Sprayer

Model No. 34215—Serial No. 40000000 and Up

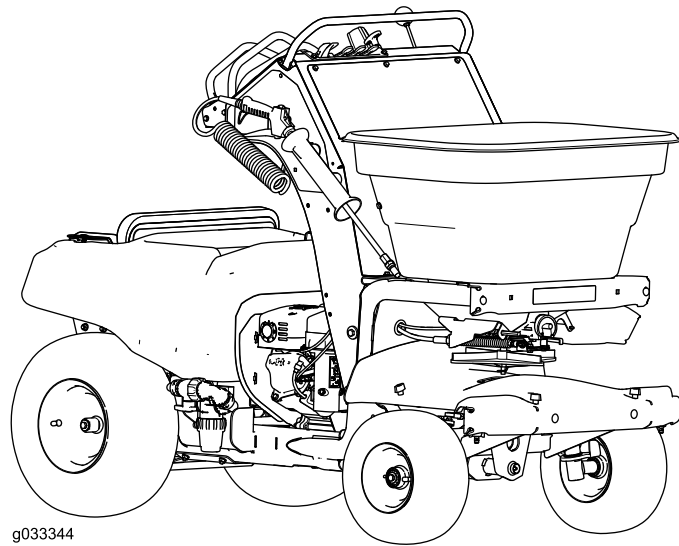

g033344



It is a violation of California Public Resource Code Section 4442 or 4443 to use or operate the engine on any forest-covered, brush-covered, or grass-covered land unless the engine is equipped with a spark arrester, as defined in Section 4442, maintained in effective working order or the engine is constructed, equipped, and maintained for the prevention of fire.

The enclosed engine owner's manual is supplied for information regarding the US Environmental Protection Agency (EPA) and the California Emission Control Regulation of emission systems, maintenance, and warranty. Replacements may be ordered through the engine manufacturer.

**⚠ WARNING**

**CALIFORNIA  
Proposition 65 Warning**

**The engine exhaust from this product contains chemicals known to the State of California to cause cancer, birth defects, or other reproductive harm.**

**Battery posts, terminals, and related accessories contain lead and lead compounds, chemicals known to the State of California to cause cancer and reproductive harm. Wash hands after handling.**

**Use of this product may cause exposure to chemicals known to the State of California to cause cancer, birth defects, or other reproductive harm.**

# Introduction

This stand-on spreader sprayer is intended for use by trained operators in residential and commercial applications. The machine is primarily designed for chemical distribution used for turf care or snow/ice removal at residential grounds, parks, sports fields, and on commercial grounds.

Read this information carefully to learn how to operate and maintain your product properly and to avoid injury and product damage. You are responsible for operating the product properly and safely.

You may contact Toro directly at [www.Toro.com](http://www.Toro.com) for product safety and operation training materials, accessory information, help finding a dealer, or to register your product.

Whenever you need service, genuine Toro parts, or additional information, contact an Authorized Service Dealer or Toro Customer Service and have the model and serial numbers of your product ready. **Figure 1** identifies the location of the model and serial numbers on the product. Write the numbers in the space provided.

**Important:** With your mobile device, you can scan the QR code on the serial number decal (if equipped) to access warranty, parts, and other product information.

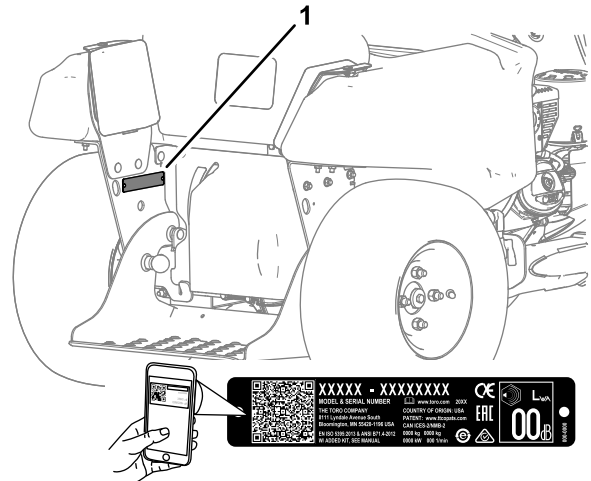

**Figure 1**

g248806

1. Location of the model and serial numbers

Model No. \_\_\_\_\_

Serial No. \_\_\_\_\_

This manual identifies potential hazards and has safety messages identified by the safety-alert symbol (**Figure 2**), which signals a hazard that may cause serious injury or death if you do not follow the recommended precautions.



**Figure 2**

Safety-alert symbol

g000502

This manual uses 2 words to highlight information. **Important** calls attention to special mechanical information and **Note** emphasizes general information worthy of special attention.

# Contents

Safety .....	4	Torquing the Axle Bolts .....	63
General Safety .....	4	Aligning the Front Wheels .....	64
Safety and Instructional Decals .....	4	Servicing the Transaxle .....	65
Setup .....	9	Controls System Maintenance .....	66
1 Checking the Tire Air Pressure .....	9	Adjusting the Pattern Control Cable for the Spreader .....	66
2 Checking the Engine-Oil Level .....	9	Maintaining the Chassis .....	67
3 Checking the Transaxle-Fluid Level .....	9	Checking the Machine for Loose Hardware .....	67
4 Connecting the Battery .....	10	Maintaining the Sprayer System .....	67
Product Overview .....	10	Checking Sprayer System .....	67
Controls .....	11	Cleaning .....	68
Machine Controls .....	11	Cleaning the Engine and the Exhaust System Area .....	68
Spreader Controls .....	13	Cleaning the Debris from the Machine .....	68
Sprayer Controls .....	14	Removing the Engine Shroud and Cleaning the Cooling Fins .....	68
Specifications .....	16	Waste Disposal .....	68
Before Operation .....	16	Storage .....	69
Before Operation Safety .....	16	Preparing the Machine for Extended or Winter Storage .....	69
Performing Daily Maintenance .....	17	Troubleshooting .....	71
Checking the Safety Interlock System .....	17	Schematics .....	75
Fuel Specification .....	18		
Using Stabilizer/Conditioner .....	18		
Filling the Fuel Tank .....	18		
During Operation .....	19		
During Operation Safety .....	19		
Operating the Machine .....	21		
Operating the Spreader .....	23		
Operating the Sprayer .....	34		
After Operation .....	43		
After Operation Safety .....	43		
Cleaning and Lubricating the Spreader .....	43		
Cleaning the Sprayer .....	44		
Transporting the Machine .....	46		
Maintenance .....	48		
Maintenance Safety .....	48		
Recommended Maintenance Schedule(s) .....	49		
Notation for Areas of Concern .....	49		
Pre-Maintenance Procedures .....	50		
Preparing the Machine .....	50		
Lubrication .....	51		
Lubricating the Grease Fittings .....	51		
Engine Maintenance .....	51		
Servicing the Air Cleaner .....	51		
Engine Oil Specification .....	52		
Checking the Engine-Oil Level .....	52		
Changing the Engine Oil .....	53		
Servicing the Spark Plug .....	54		
Servicing the Spark Arrester .....	55		
Fuel System Maintenance .....	57		
Cleaning the Fuel Sediment Cup .....	57		
Servicing the Fuel Strainer .....	57		
Electrical System Maintenance .....	59		
Servicing the Battery .....	59		
Removing and Installing the Battery .....	61		
Jump-Starting the Machine .....	62		
Servicing the Fuses .....	62		
Drive System Maintenance .....	63		
Checking the Air Pressure in the Tires .....	63		

# Safety

The following instructions are from ANSI standard B71.4-2017.

## General Safety

This product is capable of causing personal injury. Always follow all safety instructions to avoid serious personal injury.

Using this product for purposes other than its intended use could prove dangerous to you and bystanders.

- Read and understand the contents of this *Operator's Manual* before starting the engine.
- Use appropriate personal protective equipment (PPE) to guard against contact with chemicals. Chemical substances used in the sprayer system may be hazardous and toxic.
- Do not put your hands or feet near moving components of the machine.
- Do not operate the machine without all guards and other safety protective devices in place and working on the machine.

- Keep clear of any discharge area of the sprayer nozzles and spray drift. Keep bystanders and pets a safe distance away from the machine.
- Keep children out of the operating area. Never allow children to operate the machine.
- Stop the machine, shut off the engine, and remove the key before filling, emptying, servicing, or unclogging the machine.

Improperly using or maintaining this machine can result in injury. To reduce the potential for injury, comply with these safety instructions and always pay attention to the safety-alert symbol , which means Caution, Warning, or Danger—personal safety instruction. Failure to comply with these instructions may result in personal injury or death.

You can find additional safety information where needed throughout this manual.

Also, go to [www.Toro.com](http://www.Toro.com) for even more safe operating practices, including safety tips and training materials.

Not all the attachments that adapt to this machine are covered in this manual. Refer to the operator's manual provided with each attachment for additional safety instructions.

## Safety and Instructional Decals



Safety decals and instructions are easily visible to the operator and are located near any area of potential danger. Replace any decal that is damaged or missing.



133-8062

decal133-8062

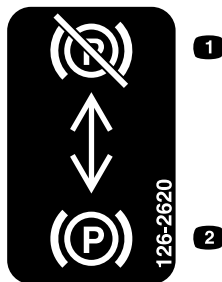

126-2620

decal126-2620

1. Pull lever up to disengage the brake.
2. Push lever down to engage the brake.

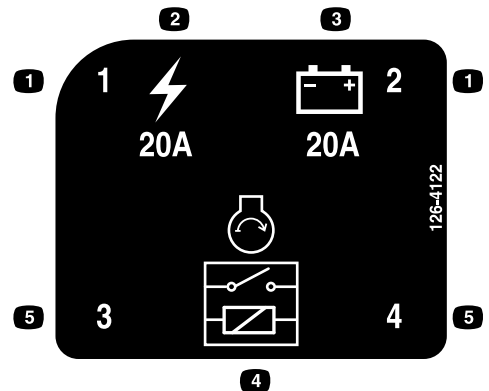

126-4122

decal126-4122

1. Fuse location
2. Main, 20 A
3. Regulator, 20 A
4. Start relay
5. Relay location

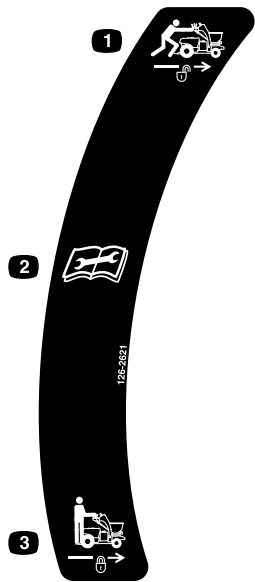

**126-2621**

decal126-2621

1. Unlock to push machine.
2. Read the instructions before servicing or performing maintenance.
3. Lock to drive machine.

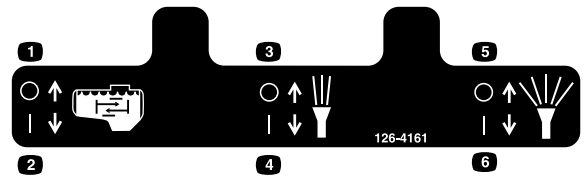

**126-4161**

decal126-4161

1. Agitation-Off
2. Agitation-On
3. Narrow spray-Off
4. Narrow spray-On
5. Wide spray-Off
6. Wide spray-On

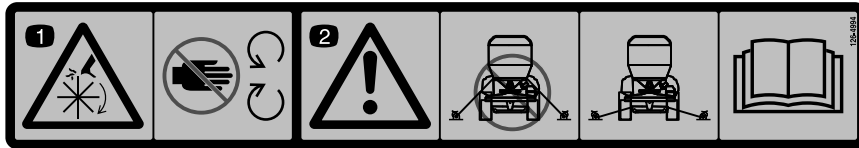

**126-4994**

decal126-4994

1. Cutting/dismemberment hazard—keep away from moving parts.
2. Warning—do not use the upper front locations as tie down points, only use the specified tie-down points; see the *Operator's Manual* for location.

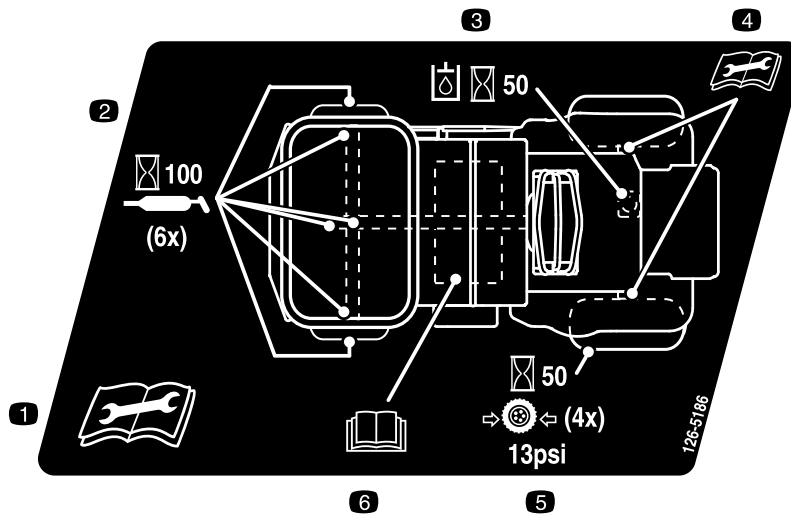

126-5186

decal126-5186

1. Read the *Operator's Manual* before servicing the machine or performing maintenance.
2. Grease the steering pivots every 100 hours.
3. Check the hydraulic fluid level every 50 hours.
4. For more information on servicing the rear axle shafts, read the *Operator's Manual*.
5. Check the tire pressure—90kPa (13 psi) every 50 hours.
6. Read the *Operator's Manual*.

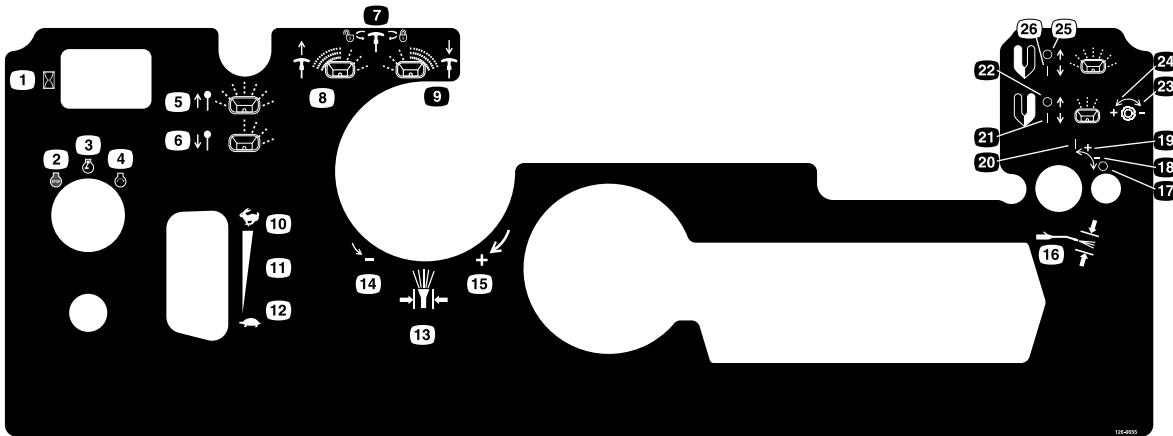

126-9655

decal126-9655

1. Hour meter
2. Engine—off
3. Engine—on
4. Engine—start
5. Deflector—pull knob up to open
6. Deflector—push knob down to close
7. Spreader pattern control—rotate counterclockwise to unlock; rotate clockwise to lock.
8. Spread pattern control—pull handle up if heavy on left side
9. Spread pattern control—push handle down if heavy on right side
10. Throttle—fast
11. Continuous-variable setting
12. Throttle-slow
13. Spray-pressure control
14. Spray pressure—decrease
15. Spray pressure—increase
16. Spray-wand-pressure control
17. Spray-wand-pressure control—off
18. Spray-wand-pressure control—decrease
19. Spray-wand pressure control—increase
20. Spray-wand pressure control—on
21. Granular-spinner lever—narrow distribution-on
22. Granular-spinner lever—narrow distribution-off
23. Granular-spinner knob—narrow distribution-decrease
24. Granular-spinner knob—narrow distribution-increase
25. Granular-spinner lever—wide distribution-off
26. Granular-spinner lever—wide distribution-on

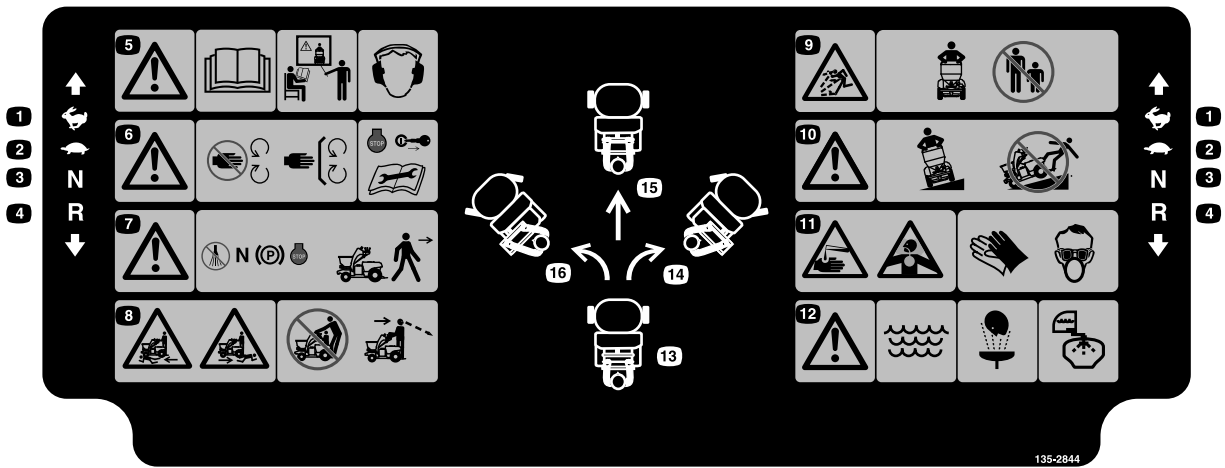

135-2844

decal135-2844

1. Fast
2. Slow
3. Neutral
4. Reverse
5. Warning—read the *Operator's Manual*; do not operate this machine unless you are trained; wear ear protection.
6. Warning—stay away from moving parts; keep all guards and shields in place; shut off the engine and remove the key before performing maintenance.
7. Warning—shut off the sprayer controls, put the machine in Neutral, engage the parking brake, and shut off the engine before leaving the machine.
8. Runover/backover hazard—do not carry passengers; look behind you when moving in reverse.
9. Thrown object hazard—keep bystanders away.
10. Warning—operate across slopes, not up and down; you can fall if operating down slopes.
11. Caustic liquid/chemical burn and toxic gas inhalation hazard—wear hand and skin protection; wear eye and respiratory protection.
12. Warning—use fresh, clean water for first-aid washing and rinsing the tank.
13. Neutral
14. Move the steering control right to turn right.
15. Move the steering control to the center to go straight.
16. Move the steering control left to turn left.

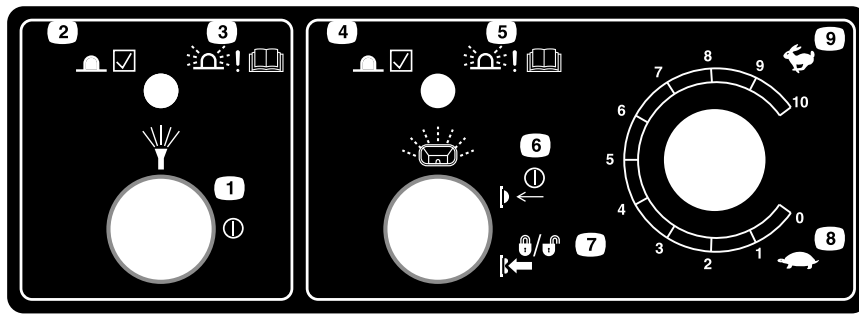

decalspreadspraycontrol

### Spreader Sprayer Control

1. Spray pump switch—On/Off
2. Solid light-normal pump operation
3. Fast flashing light-pump malfunction; see *Operator's manual*.
4. Solid light-normal operation of spreader motor and speed control.
5. Fast flashing light-spreader motor and/or speed control malfunction; see *Operator's manual*.  
Constant slow flashing light-spreader motor speed setting locked.
6. Granular impeller motor and speed control—On/Off; press push button fast.
7. Granular speed control lock/unlock-On/Off; press and hold button.
8. Speed control—slow
9. Speed control—fast



# Setup

## Loose Parts

Use the chart below to verify that all parts have been shipped.

Procedure	Description	Qty.	Use
<b>4</b>	No parts required	–	Connect the battery.

## Media and Additional Parts

Description	Qty.	Use
Operator's Manual	1	Read before operating the machine.
Key	2	Start the machine.

# 1

## Checking the Tire Air Pressure

No Parts Required

### Procedure

Check the air pressure in the front and rear tires, and if necessary, add air to the appropriate pressure; refer to [Checking the Air Pressure in the Tires \(page 63\)](#).

# 2

## Checking the Engine-Oil Level

No Parts Required

### Procedure

The engine comes with oil; check the engine-oil level and, if necessary, add to the appropriate level; refer to [Engine Oil Specification \(page 52\)](#) and [Checking the Engine-Oil Level \(page 52\)](#).

# 3

## Checking the Transaxle-Fluid Level

No Parts Required

### Procedure

The transaxle comes with fluid; check transaxle-fluid level in the expansion tank, and if necessary, add to the appropriate level; refer to [Servicing the Transaxle \(page 65\)](#).

# 4

## Connecting the Battery

No Parts Required

### Procedure

1. Remove the battery cover from the battery box (Figure 3).

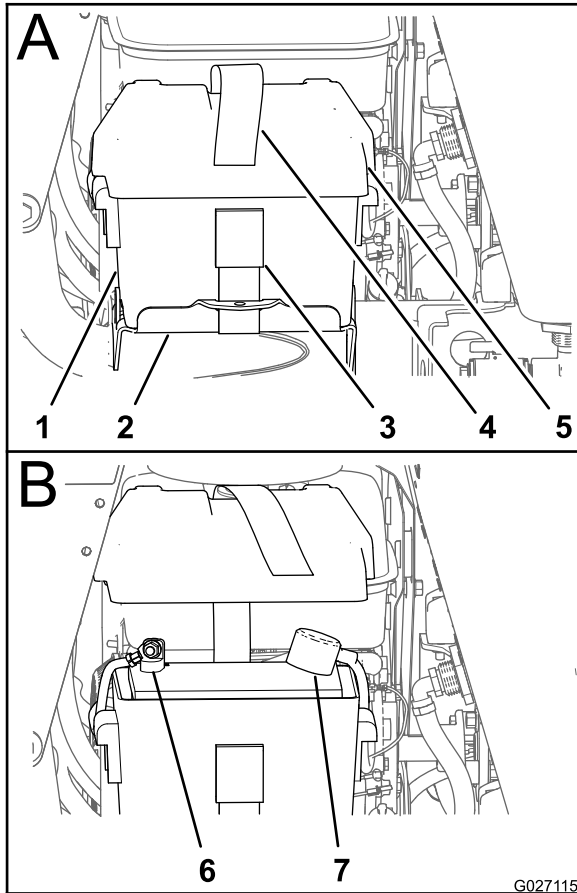

Figure 3

- |                    |                      |
|--------------------|----------------------|
| 1. Battery box     | 5. Battery cover     |
| 2. Battery support | 6. Negative terminal |
| 3. Buckle          | 7. Positive terminal |
| 4. Battery strap   |                      |

2. Install the positive-battery cable to the positive (+) battery terminal with a flanged bolt and flanged nut (Figure 3).
3. Install the negative-battery cable to the negative (-) battery terminal with a flanged bolt and flanged nut (Figure 3).
4. Install the cover on the battery box and secure the cover and box to the battery tray with the battery strap (Figure 3).

## Product Overview

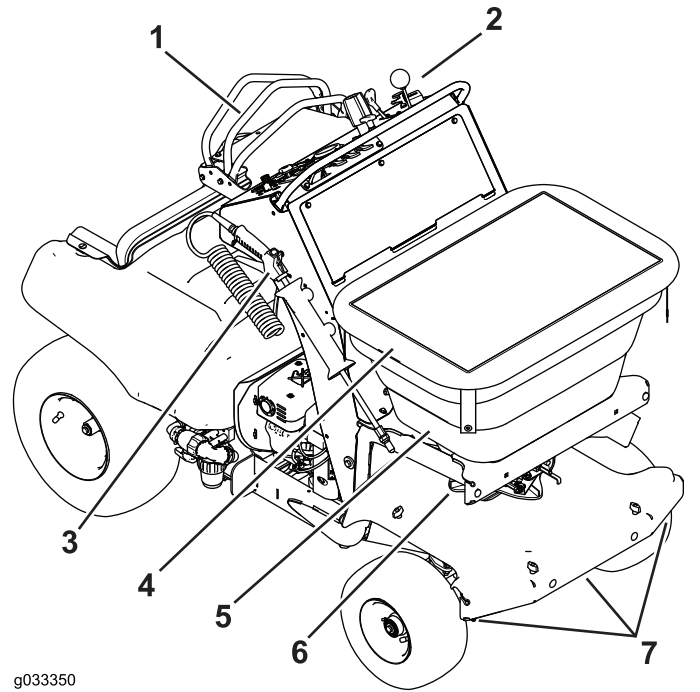
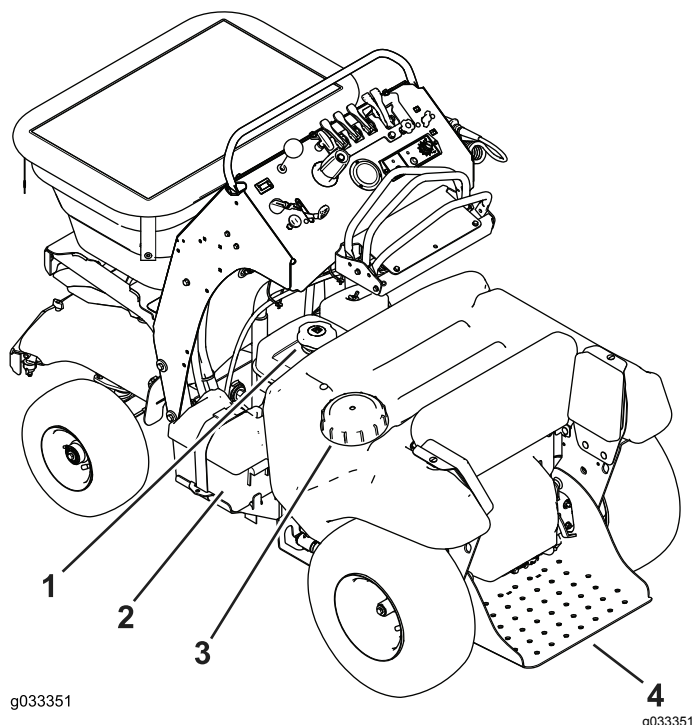

Figure 4

- |                                     |                    |
|-------------------------------------|--------------------|
| 1. Motion/steering control          | 5. Hopper          |
| 2. Engine/spreader—sprayer controls | 6. Impeller        |
| 3. Spray wand                       | 7. Sprayer nozzles |
| 4. Hopper cover                     |                    |



g033351

g033351

**Figure 5**

- |                  |                     |
|------------------|---------------------|
| 1. Fuel-tank cap | 3. Sprayer-tank cap |
| 2. Battery       | 4. Platform         |

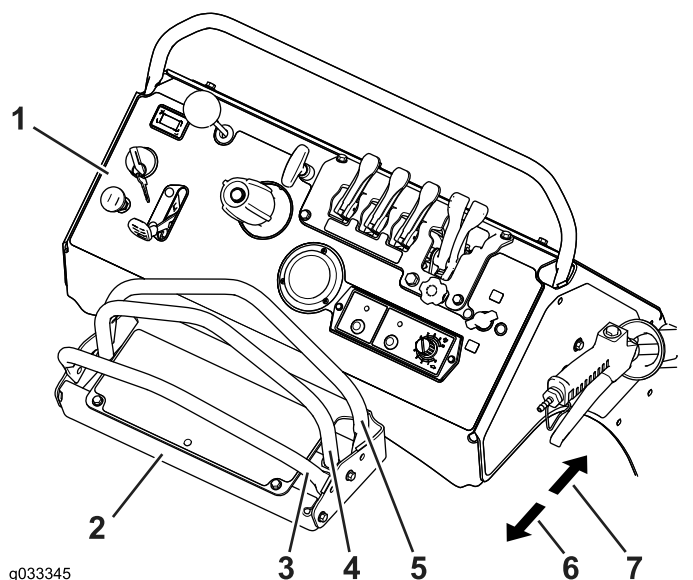

g033345

g033345

**Figure 6**

- |   |                        |
|---|------------------------|
| 1. Control console                            | 5. Front reference bar |
| 2. Steering control                           | 6. Reverse             |
| 3. Rear reference bar                         | 7. Forward             |
| 4. Motion-control lever<br>(Neutral position) |                        |

## Controls

### Machine Controls

#### Steering Control

The steering control is located behind the control console (see [Figure 6](#)).

- Move the steering control to the right or left to steer the machine to the right or left respectively.
- Moving the steering control to the center allows the machine to steer straight.

#### Motion-Control Lever

The motion-control lever, located in the center of the steering control, controls the forward and reverse motion of the machine (see [Figure 6](#)).

- Move the motion-control lever forward or backward to drive the machine respectively.

**Note:** The machine speed is proportional to the amount that you move the motion-control lever.

- When you move the motion-control lever to the center position, the machine should stop.

**Note:** When you release the motion-control lever, it should return to the NEUTRAL position.

**Important:** If the motion-control lever does not return to the NEUTRAL position when you release it, contact an Authorized Service Dealer.

## Throttle Control

The throttle control (the red lever) is located at the left side of the control console (Figure 7).

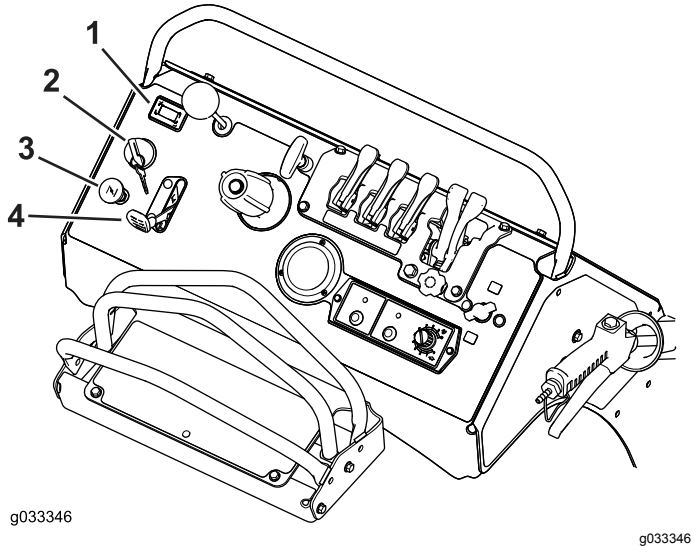

Figure 7

- |                    |             |
|--------------------|-------------|
| 1. Hour meter      | 3. Choke    |
| 2. Ignition switch | 4. Throttle |

## Choke Control

The choke control is located at the left side of the control console; you use it to help start a cold engine (Figure 7).

**Note:** Do not start or run a warm engine with the choke in the ON position.

- Pull up on the choke control to set the choke to the ON position.
- Push down on the choke control to set the choke to the OFF position.

## Ignition Switch

The ignition switch is located at the left side of the control console (Figure 7).

Use the ignition switch to start and shut off the engine. The ignition switch has three positions, OFF, ON and START.

**Note:** You must engage the parking brake to start the engine.

## Hour Meter

The hour meter is located above the ignition switch at the left side of the control console (Figure 7).

The hour meter records the number of hours that the machine has operated.

## Fuel-Shut-Off Valve

The fuel-shut-off valve is located at the front, right side of the engine below the fuel tank (Figure 8).

**Note:** Close the fuel-shut-off valve when the machine is not used for a few days, during transport to and from the job site, or when the machine is parked inside a building.

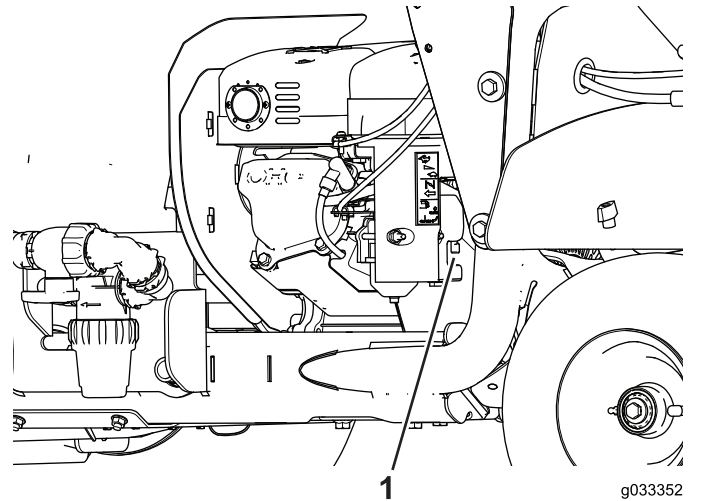

Figure 8

1. Fuel-shut-off valve (right side of the engine)

## Parking-Brake Lever

The parking-brake lever is located above the platform on the right side (Figure 9).

- To engage the parking brake, push the parking-brake lever down.

**Note:** The brake lever engages a parking brake in the transaxle.

- To release the parking brake, pull the lever up.

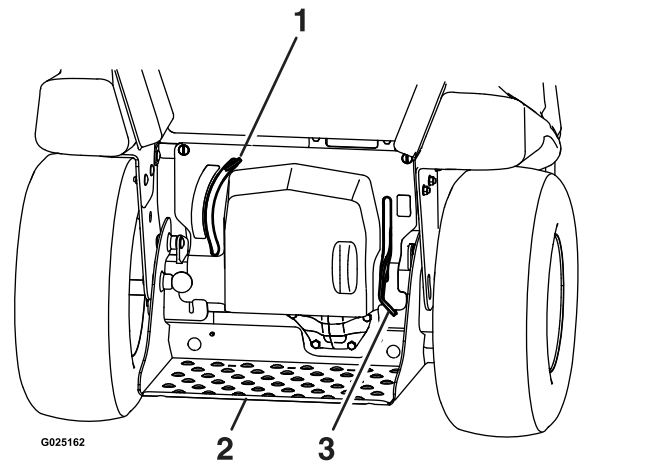

Figure 9

1. Drive-wheel-release lever
2. Platform
3. Park-brake lever

**Note:** When parking on a steep slope, chock or block the wheels in addition to engaging the parking brake. When transporting the machine, engage the parking brake and bind the machine to the transport vehicle.

### Drive-Wheel-Release Lever

The drive-wheel-release lever is located above the platform on the left side (Figure 9).

Use the drive-wheel-release lever to disengage the hydrostatic-drive system to move the machine by hand.

- To push or pull the machine, move the drive-wheel-release lever up.
- To operate the machine, move the drive-wheel-release lever down.

## Spreader Controls

### Deflector Gate Control

The deflector-gate control is located to the right of the hour meter on the control console (Figure 10).

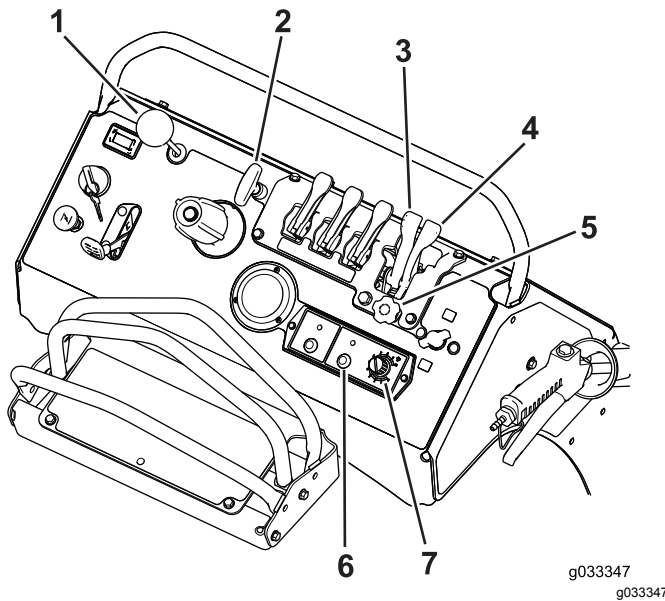

Figure 10

- |  |  |
|--|--|
| 1. Deflector-gate control                  | 5. Narrow-spreader distribution flow-rate knob |
| 2. Spreader-pattern control                | 6. Impeller On/Off switch                      |
| 3. Wide-distribution impeller-gate lever   | 7. Impeller-speed control                      |
| 4. Narrow-distribution impeller-gate lever |  |

Use the deflector-gate control to temporarily stop the discharge of granular materials from the left side of the spreader. Close the deflector gate with the control when it is not desirable to broadcast granular materials onto sidewalks, parking lots, or patios.

- Push the knob for the deflector-gate control down to close the gate and temporarily deflect the granular materials.
- Pull the knob up to open the deflector gate for full granular broadcasting.

### Spreader-Pattern Control

The spreader-pattern control is located to the right of the deflector-gate control at the control console (Figure 10).

Use the spreader-pattern control to broadcast a heavier pattern of granular material to the left or right side of the machine.

- To broadcast a heavier pattern to the left, unlock the spreader-pattern control, pull the control up slightly, and lock the control.
- To broadcast a heavier pattern to the right, unlock the spreader-pattern control, push the control down slightly, and lock the control.

### Wide-distribution Impeller-Gate Lever

The wide-distribution impeller-gate lever is the fourth lever located at the top center of the control console (Figure 10).

- To broadcast a wide pattern of granular material, pull the wide-distribution impeller-gate lever rearward fully to the full open position.
- To close the impeller gate, push the wide-distribution impeller-gate lever forward full closed position.

### Narrow-distribution Impeller-Gate Lever

The narrow-distribution impeller-gate lever is the fifth lever located at the top center of the control console (Figure 10).

- To broadcast a narrow pattern of granular material, pull the narrow-distribution impeller-gate lever rearward fully to the limited OPEN position.
- To close the impeller gate, push the wide-distribution impeller-gate lever forward fully.

**Note:** Only the wide-distribution impeller-gate lever closes the impeller gate. Pushing the wide-distribution impeller-gate lever forward also resets the narrow-distribution impeller-gate lever to the forward position.

### Narrow-Spreader Distribution Flow-Rate Knob

The narrow-spreader distribution flow-rate knob is located below the wide- and narrow-impeller-gate levers (Figure 10).

Use the narrow-spreader distribution-flow-rate knob to control the discharge rate of granular material from the hopper onto the impeller when the narrow-distribution impeller-gate lever is in the OPEN position (limited).

- Rotate the narrow-spreader distribution-flow-rate knob clockwise to decrease the discharge rate of granular material from the hopper.
- Rotate the distribution flow-rate-knob counterclockwise to increase the discharge rate of granular material from the hopper.

### Impeller On/Off Switch

The impeller On/Off switch is located below the impeller-distribution flow-rate knob at the bottom of the control console (Figure 10).

Use the impeller On/Off switch to run the electric motor that drives the impeller.

- Press the impeller On/Off switch up to run the impeller.
- Press the impeller On/Off switch down to stop the impeller.

### Impeller-speed Control

The impeller-speed control is located to the right of the impeller On/Off switch at the bottom of the control console (Figure 10).

Use the impeller-speed control to adjust the rotational speed of the impeller.

- Rotate the impeller-speed control counterclockwise to decrease the rotational speed of the impeller.
- Rotate the impeller-speed control clockwise to increase the impeller speed.

### Drop-rate Cam and Linkage

The drop-rate cam and linkage are located at the front of the machine and below the hopper on the spreader (Figure 11).

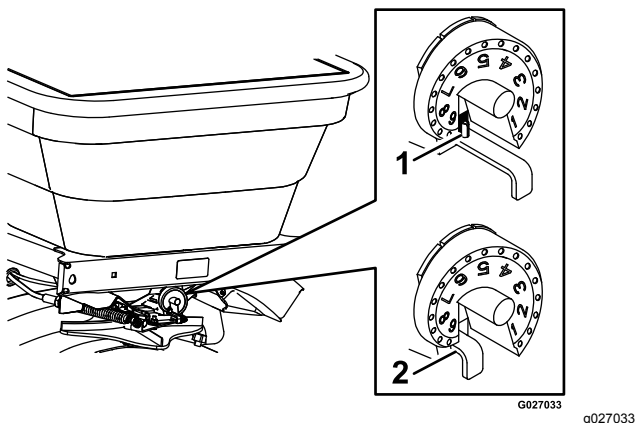

Figure 11

1. Slot-maximum position
2. Linkage

Use the drop-rate cam to set the maximum amount of material to be dispensed through the impeller gate and onto the impeller.

The slot in the cam, after setting 9 on the cam, allows the impeller gate to be opened to the maximum position. This setting can be used for dry sand, ice melt, or other materials that are difficult to spread.

**Note:** Use cam setting 9 may when you are cleaning out the hopper.

## Sprayer Controls

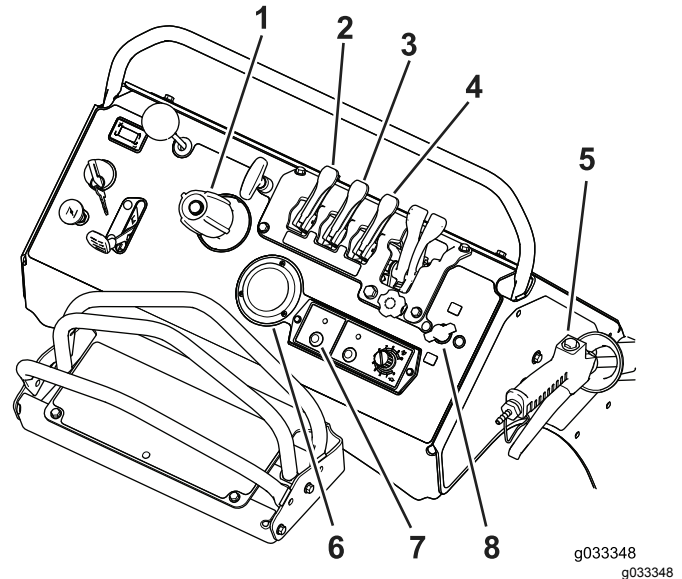

Figure 12

- |                               |                           |
|-------------------------------|---------------------------|
| 1. Sprayer-pressure control   | 5. Sprayer wand           |
| 2. Tank-agitation lever       | 6. Sprayer-pressure gauge |
| 3. Narrow-spray pattern lever | 7. Sprayer-pump switch    |
| 4. Wide-spray pattern lever   | 8. Wand pressure control  |

### Sprayer Pressure Control

The sprayer-pressure control is located on the control console (Figure 12).

- Rotate the sprayer-pressure control clockwise to increase the pressure to the sprayer nozzles
- Rotate the pressure-control counterclockwise to decrease nozzle pressure.

### Tank Agitation Lever

The tank-agitation lever is located on the control console (Figure 12).

Setting the tank-agitation lever to the ON position allows the sprayer pump to circulate the content in the spray tank to keep the chemical solution mixed.

- Pull the tank-agitation lever rearward to circulate the content in the spray tank.
- Push the lever forward to stop circulating the content in the spray tank.

**Note:** Do not use agitation while spraying. Shut off the tank agitation to ensure proper spray distribution.

**Note:** Run the engine speed above idle and run the sprayer pump for the tank agitation to work effectively.

### Narrow-Spray Pattern Lever

The narrow-spray pattern lever is located on the control console (Figure 12).

- To turn ON the sprayer in a narrow-spray pattern (the center nozzle only), pull the narrow-spray pattern lever toward you.
- To turn OFF the sprayer, push the narrow-spray pattern lever away from you.

### Wide-Spray Pattern Lever

The wide-spray pattern lever is located on the control console (Figure 12).

- To turn ON the sprayer in a wide-spray pattern (the right and left nozzles), pull the wide-spray pattern lever toward you.
- To turn OFF the sprayer, push the wide-spray pattern lever away from you.

### Sprayer-Pressure Gauge

The sprayer-pressure gauge is located on the control console (Figure 12).

Use the pressure gauge to see the fluid pressure in the sprayer system.

### Sprayer-Pump Switch

The sprayer-pump switch is located on the control console (Figure 12).

Use the sprayer-pump switch to start and stop the pump when spraying or circulating the fluid in the sprayer tank (tank-agitation).

- To start the pump, push down on the top of the sprayer-pump switch.
- To stop the pump, push down on the bottom of the switch.

### Spray-Wand Trigger and Trigger Lock

The spray-wand trigger and trigger lock are located on the bottom of the spray-wand handle (Figure 12 and Figure 13).

- To use the spray wand, hold the handle of the wand squeeze the trigger.
- To lock the trigger to the ON position, fully squeeze the trigger against the handle and then latch the trigger lock over the trigger; to unlock the trigger, unlatch the trigger lock from the trigger.
- Release the trigger to stop the spray.

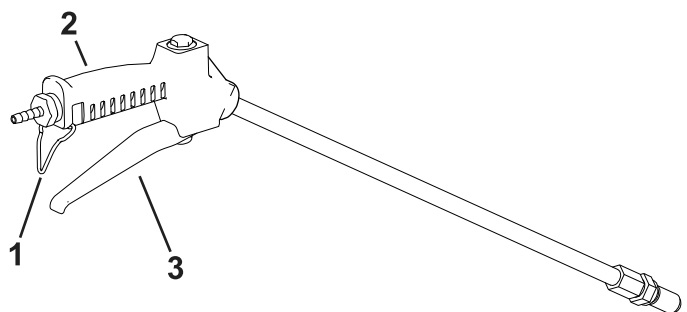

g033343  
g033343

**Figure 13**

1. Trigger lock
2. Spray-wand handle
3. Trigger

### Tank Drain Valve

The tank drain valve is located at the left side and under the sprayer tank (Figure 15).

Use the tank drain valve to empty the sprayer tank of liquid chemicals.

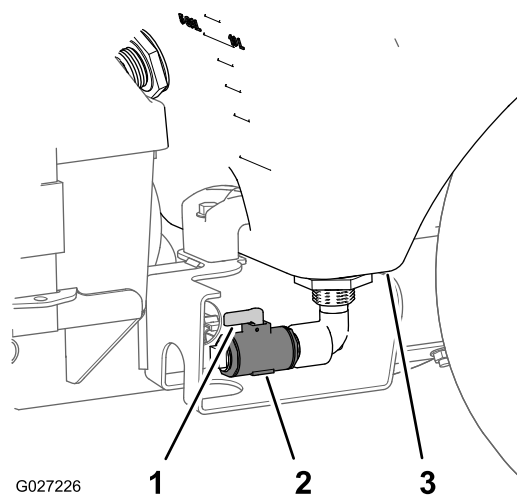

G027226

g027226

**Figure 14**

1. Handle (open position)
2. Tank drain valve
3. Sprayer tank

- To open the valve, rotate the handle of the tank drain valve 90° clockwise (lever in-line with valve).
- To close the valve, rotate the handle 90° counterclockwise.

### Sprayer-Pump-Supply Valve

The sprayer-pump-supply valve is located at the right side of the machine and under the sprayer tank (Figure 15).

Use the sprayer-pump-supply valve to shut off the flow of liquid chemicals to the pump.

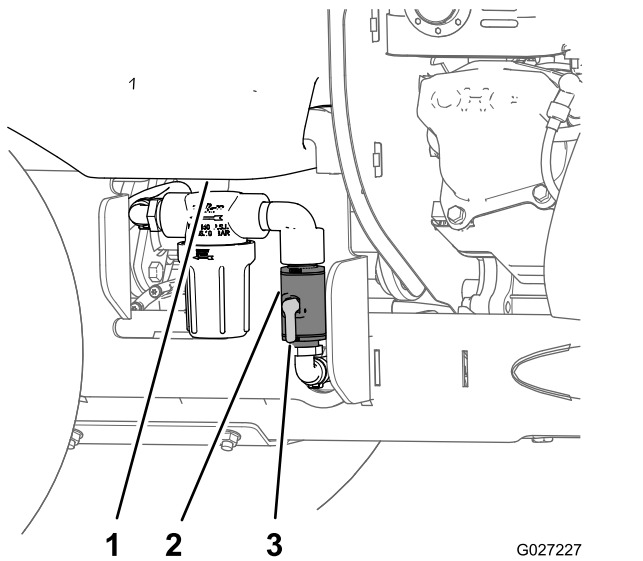

**Figure 15**

- 1. Sprayer tank
- 2. Sprayer-pump-supply valve
- 3. Handle (open position)

- To open the valve, rotate the handle valve 90° clockwise (lever in-line with valve).
- To close the valve, rotate the handle 90° counterclockwise.

## Specifications

<b>Overall width</b>		90 cm (35.5 inches)
<b>Overall length</b>		171 cm (67.5 inches)
<b>Overall height</b>		131 cm (51.5 inches)
<b>Weight</b>	sprayer tank and hopper empty	227 kg (500 lb)
	only hopper full	307 kg (676 lb)
	only sprayer tank full	309 kg (682 lb)
	sprayer tank and hopper empty and 1 extra bag of granular material in the tank	412 kg (909 lb)
<b>Maximum machine weight</b>	loaded machine + operator	≤ 513 kg (1130 lb)
<b>Hopper capacity</b>		79 kg (175 lb)
<b>Sprayer tank capacity</b>		76 L (20 US gallon)
<b>Maximum ground speed</b>	forward	9 kph (5.5 mph)

# Operation

**Note:** Determine the left and right sides of the machine from the normal operating position.

## Before Operation

### Before Operation Safety

#### General Safety

- Park the machine on a level surface; shut off the engine; engage the parking brake; remove the key; wait for all movement to stop; and allow the machine to cool before adjusting, cleaning, storing, or servicing it.
- Never allow children or untrained people to operate the machine. Local regulations may restrict the age of the operator. The owner is responsible for training all operators and mechanics.
- Become familiar with the safe operation of the equipment, operator controls, and safety signs.
- Know how to stop the machine and shut off the engine quickly.
- Check that operator-presence controls, safety switches, and shields are attached and functioning properly. Do not operate the machine unless they are functioning properly.
- If the machine does not function correctly or is damaged in any way, do not use the machine. Correct the problem before you operate the machine or attachment.
- Ensure that the operator area is clean and free from chemical residue and debris buildup.
- Ensure that all fluid line connectors are tight and that all hoses are in good condition before applying pressure to the system.

#### Chemical Safety

Chemical substances used in the sprayer system may be hazardous and toxic to you, bystanders, and animals, and they may damage plants, soil, and other property.

If you will use more than 1 chemical, read the information on each chemical. Refuse to operate or work on the sprayer if this information is not available.

Before working on a sprayer system, ensure that it has been neutralized and triple rinsed according to the recommendations of the chemical manufacturer(s) and that all the valves have been cycled 3 times.



Verify that there is an adequate supply of clean water and soap nearby, and immediately wash off any chemicals that contact you.

- Carefully read and follow the chemical warning labels and material safety data sheets (MSDS) for all chemicals used, and protect yourself according to the chemical manufacturer's recommendations.
- Always protect your body while using chemicals. Use the appropriate personal protective equipment (PPE) to guard against contact with chemicals, such as the following:
  - safety glasses, goggles, and/or face shield
  - a chemical suit
  - a respirator or filter mask
  - chemical-resistant gloves
  - rubber boots or other substantial footwear
  - a clean change of clothes, soap, and disposable towels for cleanup
- Obtain proper training before using or handling chemicals.
- Use the correct chemical for the job.
- Follow the chemical manufacturer's instructions for the safely applying the chemical. Do not exceed the recommended system application pressure.
- Do not fill, calibrate, or clean the machine while people, especially children, or pets are in the area.
- Handle chemicals in a well-ventilated area.
- Have clean water available, especially when filling the spray tank.
- Do not eat, drink, or smoke while working near chemicals.
- Do not clean spray nozzles by blowing through them or placing them in your mouth.
- Always wash your hands and other exposed areas as soon as possible after working with chemicals.
- Keep chemicals in their original packages and stored in a safe location.
- Properly dispose of unused chemicals and chemical containers as instructed by the chemical manufacturer and your local codes.
- Chemicals and fumes are dangerous; never enter the tank or place your head over or in the opening of a tank.
- Follow all local, state, and federal regulations for spreading or spraying chemicals.

## Fuel Safety

- Use extreme care in handling fuel. It is flammable and its vapors are explosive.

- Extinguish all cigarettes, cigars, pipes, and other sources of ignition.
- Use only an approved fuel container.
- Do not remove the fuel cap or fill the fuel tank while the engine is running or hot.
- Do not add or drain the fuel in an enclosed space.
- Do not store the machine or fuel container where there is an open flame, spark, or pilot light, such as on a water heater or other appliance.
- If you spill fuel, do not attempt to start the engine; avoid creating any source of ignition until the fuel vapors have dissipated.

## Performing Daily Maintenance

Before starting the machine each day, perform the following daily-check procedures:

- [Checking the Engine-Oil Level \(page 52\)](#)
- [Checking the Safety Interlock System \(page 17\)](#)
- [Checking the Machine for Loose Hardware \(page 67\)](#)

## Checking the Safety Interlock System

**Service Interval:** Before each use or daily

### **⚠ CAUTION**

**If interlock switch is disconnected or damaged the machine could operate unexpectedly causing personal injury.**

- **Do not tamper with the interlock switch.**
- **Check the operation of the interlock switch daily and replace damaged switch before operating the machine.**

**Important:** Ensure that the safety mechanisms on your machine are connected and in proper operating condition prior to operating your machine.

The safety interlock system is designed to prevent the engine from starting unless you engage the parking brake.

## Testing the Starter Interlock

**Service Interval:** Before each use or daily

1. Move the machine to a level surface.
2. Chock the wheels of the machine.
3. Disconnect the spark-plug wires.
4. Release the parking brake.
5. With the motion-control lever in the NEUTRAL position turn the key to the START position.

**Note:** The starter must not rotate the engine.

- If the starter rotates the engine of your machine—the machine does not pass this test, do not operate it. Contact your authorized Toro distributor.
- If the starter does not rotate the engine—the machine does pass the test: engage the parking brake, connect the spark-plug wire to the spark plug, and remove the chock(s) from the wheels.

## Fuel Specification

<b>Petroleum fuel</b>	Use unleaded gasoline with an octane rating of 87 or higher ((R+M)/2 rating method).
<b>Ethanol blended fuel</b>	Use an unleaded-gasoline blend with up to 10% ethanol (gasohol) or 15% MTBE (methyl tertiary butyl ether) by volume is acceptable. Ethanol and MTBE are not the same.  Gasoline with 15% ethanol (E15) by volume is not approved for use. Never use gasoline that contains more than 10% ethanol by volume, such as E15 (contains 15% ethanol), E20 (contains 20% ethanol), or E85 (contains up to 85% ethanol). Using unapproved gasoline may cause performance problems and/or engine damage which may not be covered under warranty.

**Important:** For best results, use only clean, fresh fuel (less than 30 days old).

- Do not use gasoline containing methanol.
- Do not store fuel either in the fuel tank or fuel containers over the winter unless you use a fuel stabilizer.
- Do not add oil to gasoline.

## Using Stabilizer/Conditioner

Use a fuel stabilizer/conditioner in the machine to provide the following benefits:

**Important:** Do not use fuel additives containing methanol or ethanol.

Add the correct amount of fuel stabilizer/conditioner to the gasoline.

**Note:** A fuel stabilizer/conditioner is most effective when mixed with fresh gasoline. To minimize the chance of varnish deposits in the fuel system, use fuel stabilizer at all times.

## Filling the Fuel Tank

**Fuel tank capacity:** 6.1 L (1.6 US gallons)

**Note:** Refueling the engine is difficult when using a larger refueling container such as a container with a 19 L (5 US gal) capacity.

To make fueling the machine easier, use a 4 to 8 L (1 to 2 US gal) fuel container and a funnel.

1. Park the machine on a level surface and shut off the engine.
2. Allow the engine to cool.
3. Clean around the fuel-tank cap and remove it (Figure 16).

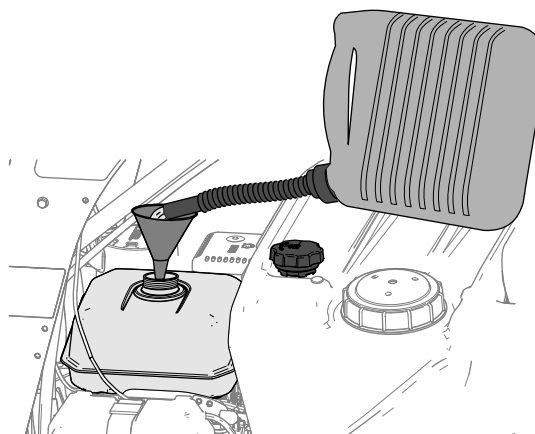

Figure 16

g249048

4. Fill the tank with fuel (Figure 16) to within 6 to 13 mm (1/4 to 1/2 inch) from the top of the tank. **Do not fill into the filler neck of the tank.**

**Important:** Do not fill the tank more than 6 mm (1/4 inch) from the top of the tank because the fuel needs room to expand.

5. Install the fuel-tank cap securely.
6. Wipe up any spilled fuel.

# ***During Operation***

## **During Operation Safety**

### **General Safety**

- The owner/operator can prevent and is responsible for accidents that may cause personal injury or property damage.
- Wear appropriate clothing, including eye protection; long pants; substantial, slip-resistant footwear; and hearing protection. Tie back long hair, secure loose clothing, and do not wear loose jewelry.
- Wear appropriate personal protective equipment as directed in [Chemical Safety \(page 16\)](#).
- Use your full attention while operating the machine. Do not engage in any activity that causes distractions; otherwise, injury or property damage may occur.
- Do not operate the machine while ill, tired, or under the influence of alcohol or drugs.
- Never carry passengers on the machine and keep bystanders and pets away from the machine during operation.
- Do not try to stabilize the machine by putting your foot on the ground. If you lose control of the machine, step off the platform and away from the machine.
- Do not place your feet under the platform.
- Do not move the machine unless you are standing with both feet on the platform and your hands are holding onto the reference bars.
- Operate the machine only in good visibility to avoid holes or hidden hazards.
- Before you start the engine, ensure that you are in the operating position, the transmission is in neutral, and the parking brake is engaged.
- Before you start the engine, ensure that you are in the operating position, the transmission is in neutral, and the parking brake is engaged.
- Use care when approaching blind corners, shrubs, trees, or other objects that may obscure your vision.
- Ensure that you have good footing while using this machine, especially when backing up.
- Keep clear of any discharge area of the sprayer nozzles and spray drift. Keep bystanders and pets a safe distance away from the machine.
- Never spray or spread chemicals while people, especially children, or pets are nearby.
- Look behind and down before backing up to be sure of a clear path.
- Use care when approaching blind corners, shrubs, trees, or other objects that may obscure your vision.
- Do not operate the machine near drop-offs, ditches, or embankments. The machine could suddenly roll over if a wheel goes over the edge or if the edge gives way.
- Reduce the speed and load when operating on rough terrain, uneven ground, and near curbs, holes, and other sudden changes in terrain. Loads may shift, causing the machine to become unstable.
- Stop the machine, shut off the engine, remove the key, engage the parking brake, and inspect for damage after striking an object or if there is an abnormal vibration in the machine. Make all necessary repairs before resuming operation.
- Slow down and use caution when making turns and crossing roads and sidewalks with the machine. Always yield the right-of-way.
- Use extra caution when operating the machine on wet surfaces, in adverse weather conditions, at higher speeds, or with a full load. Stopping time and distance increase in these conditions.
- Never run an engine in an enclosed area where exhaust gasses can collect.
- Never leave a running machine unattended.
- Do not touch the engine or muffler while the engine is running or soon after it has shut off. These areas may be hot enough to cause burns.
- Before leaving the operating position, do the following:
  - Stop the machine on level ground.
  - Shut the wide-distribution impeller-gate for the spreader and shut off the sprayer-pump switch.
  - Shut off the engine and remove the key.
  - Engage the parking brake.
  - Wait for all moving parts to stop.
- Do not operate the machine when there is the risk of lightning.
- Do not use the machine as a towing vehicle.
- Do not change the governor speed or overspeed the engine.
- Use accessories and attachments approved by Toro only.

# Sprayer and Spreader Operation Safety

- The spray wand traps liquids under high pressure, even when engine is off. High-pressure spray could cause serious injury or death.
    - Keep clear of nozzle and do not direct spray or stream at people, pets, or non-work area property.
    - Do not direct spray on or near electrical-power components or source.
    - Do not attach hoses or other components to the end of the spray-wand nozzle.
    - Do not attempt to disconnect the spray wand from the machine while the system is pressurized.
    - Do not use spray wand if trigger lock is damaged or missing.
    - Rotate the spray-wand lock to the OFF position when job is complete.
  - Do not touch the impeller for the spreader while the impeller is rotating.
  - Stop spreading/spraying when making tight turns to minimize chemical drift.
  - Chemicals may drift and cause injury to people and animals; it may also damage plants, soil, or other property.
  - Liquid loads and granular materials can shift. This shifting happens most often while turning, going up or down hills, suddenly changing speeds, or while driving over rough surfaces. Shifting loads can cause the machine to tip over.
  - Safely relieve pressure from spray wand every time the engine is shut off.
  - When draining or relieving system, do not let anyone stand in front of nozzles and do not drain on a person's feet.
- use common sense and good judgment when performing this survey.
  - Avoid starting, stopping, or turning the machine on slopes. Travel up and down on slopes. Avoid making sudden changes in speed or direction. If you must turn the machine, turn it slowly and gradually downhill, if possible. Use care when reversing the machine.
  - Do not operate a machine when you are uncertain about the traction, steering, or stability.
  - Remove or mark obstructions such as ditches, holes, ruts, bumps, rocks, or other hidden hazards. Tall grass can hide obstructions. Uneven terrain could overturn the machine.
  - Be aware that operating the machine on wet surfaces, across slopes, or downhill may cause the machine to lose traction. Loss of traction to the wheels may result in sliding and a loss of braking and steering.
  - Use extreme caution when operating the machine near drop-offs, ditches, embankments, water hazards, or other hazards. The machine could suddenly roll over if a wheel goes over the edge or the edge caves in. Establish a safety area between the machine and any hazard.
  - Use extra care while operating the machine with attachments; they can affect the stability of the machine.
  - If the engine stalls or you begin to lose momentum while climbing a hill, gradually apply the brakes and slowly back straight down the hill.
  - Always keep the transmission in gear (if applicable) when you drive the machine down a slope.
  - Do not park the machine on an incline.
  - The weight of the material in the tank can change the handling of the machine. To avoid loss of control and personal injury, follow these guidelines:
    - When operating with a heavy load, reduce your speed and allow for sufficient braking distance. Do not suddenly apply the brakes. Use extra caution on slopes.
    - Liquid loads shift, especially while turning, going up or down slopes, suddenly changing speeds, or while driving over rough surfaces. Shifting loads can cause the machine to tip over.

## Slope Safety

Slopes are a major factor related to loss of control and rollover accidents, which can result in severe injury or death. You are responsible for safe slope operation. Operating the machine on any slope requires extra caution.

- Review the slope instructions listed below for operating the machine on slopes and to determine whether you can operate the machine in the conditions on that day and at that job site. Changes in the terrain can result in a change in slope operation for the machine.
- Determine if the slope is safe for machine operation, including surveying the site. Always

# Operating the Machine

## Extending and Retracting the Operator's Platform

### Extending the Operator's Platform

1. Pull the platform-lock knob inward until the pin of the platform lock clears the upper hole in the chassis (Figure 17).

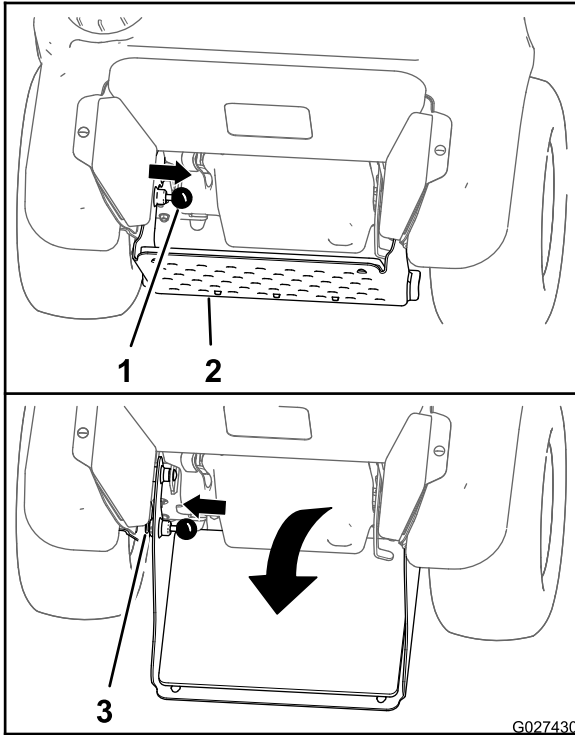

Figure 17

1. Platform-lock knob
2. Operator's platform
3. Lower chassis hole

2. Rotate the operator's platform down until the pin of the platform lock aligns with the lower hole in the chassis (Figure 17).
3. Move the platform-lock knob outward until the pin protrudes through the lower hole (Figure 17).

### Retracting the Operator's Platform

1. Pull the platform-lock knob inward until the pin clears the upper hole in the chassis (Figure 17).
2. Rotate the operator's platform up until the pin of the platform lock aligns with the upper hole in the chassis (Figure 17).
3. Move the platform-lock knob outward until the pin protrudes through the upper hole (Figure 17).

## Opening and Closing the Fuel-Shut-Off Valve

Control fuel flow to the engine with the fuel-shut-off valve as follows:

- Rotate the handle for the fuel-shut-off valve 90 degrees clockwise to open the valve.
- Rotate fuel-shut-off valve handle 90 degrees counterclockwise to close the valve.

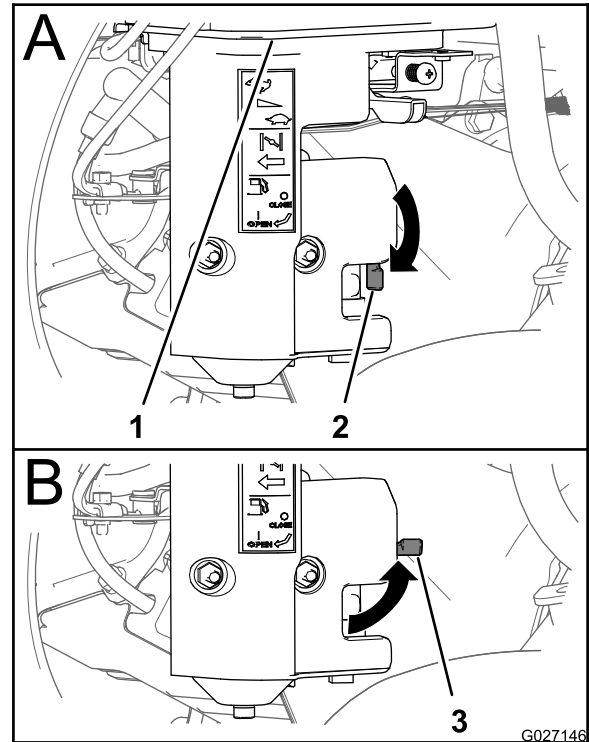

Figure 18

1. Fuel tank
2. Fuel-shutoff valve (open position)
3. Fuel-shutoff valve (closed position)

## Starting the Engine

1. Ensure that the fuel-shutoff valve is open; refer to [Opening and Closing the Fuel-Shut-Off Valve \(page 21\)](#).
2. Move the steering-control/motion-control lever in NEUTRAL position and engage the parking brake; refer to [Steering Control \(page 11\)](#), [Motion-Control Lever \(page 11\)](#), and [Parking-Brake Lever \(page 12\)](#).

**Note:** To start the engine, you must engage the parking brake. (You can start the engine while you are off the platform.)

3. Move the throttle lever midway between the SLOW and FAST positions; refer to [Throttle Control \(page 12\)](#).

- If the engine is cold, pull up the choke control to the ON position; refer to [Choke Control \(page 12\)](#).

**Note:** If the engine is warm, push down the choke lever to the OFF position.

- Rotate the ignition switch to the START position; refer to [Ignition Switch \(page 12\)](#).

**Note:** When the engine starts, release the switch.

**Important:** Do not crank the engine continuously for more than 10 seconds at a time. If the engine does not start, allow a 60 second cool-down period between starting attempts. Failure to follow these guidelines can overheat the starter motor

- If the choke control is in the ON position, gradually move the lever down, toward the OFF position as the engine warms up.

## Shutting Off the Engine

- Move the steering-control/motion-control lever to the NEUTRAL position and bring the machine to a full stop; refer to [Steering Control \(page 11\)](#) and [Motion-Control Lever \(page 11\)](#).
- Place the throttle in the midway between the SLOW and FAST positions; refer to [Throttle Control \(page 12\)](#).
- Run the engine for a minimum of 15 seconds, then turn the ignition switch to the OFF position; refer to [Ignition Switch \(page 12\)](#).
- Engage the parking brake; refer to [Parking-Brake Lever \(page 12\)](#).
- Remove the key; refer to [Ignition Switch \(page 12\)](#).
- Close the fuel-shutoff valve when you are not using the machine for a few days, when transporting it, or when it is parked inside a building; refer to [Opening and Closing the Fuel-Shut-Off Valve \(page 21\)](#).

## Driving the Machine

### ⚠ CAUTION

Machine can turn rapidly by moving the steering control to the far right or left. Operator may lose control of the machine, which may cause damage to the machine or injury.

- Use caution when making turns.
- Slow down the machine before making sharp turns.

**Important:** If the motion-control lever does not return to the NEUTRAL position when you release it, contact an Authorized Service Dealer.

**Important:** To begin moving the machine (forward or backward), the parking-brake lever must be released (pulled up) before you move the motion-control lever.

## Driving the Machine Forward

- Move the motion-control lever to the NEUTRAL position.
- Release the parking brake.
- To drive the machine, perform the following:
  - To move the machine forward in a straight line, center the steering control and move the motion-control lever forward.

**Note:** The machine moves faster the farther you move the motion-control lever away from the NEUTRAL position.

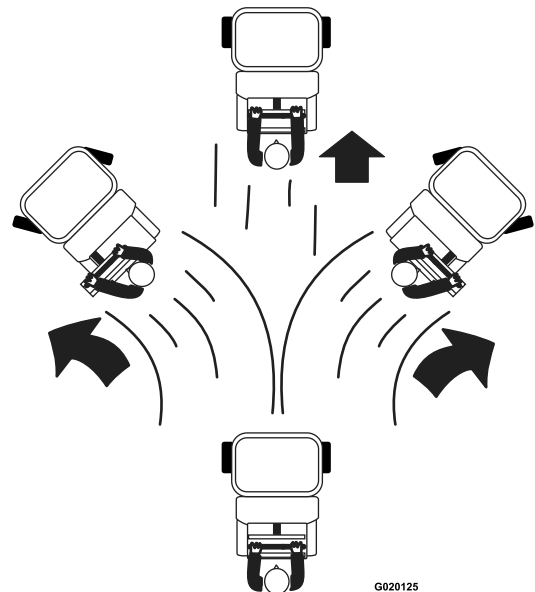

Figure 19

- To turn left or right, move the steering control toward the desired turn direction.
- To stop the machine, move the motion-control lever in the NEUTRAL position.

**Note:** Stopping distance may vary depending on the spreader-sprayer load.

**Note:** When you release the motion-control lever, it automatically returns to the NEUTRAL position.

## Driving the Machine in Reverse

1. Move the motion-control lever to the NEUTRAL position.
2. To move the machine rearward in a straight line, slowly move the motion-control lever rearward.

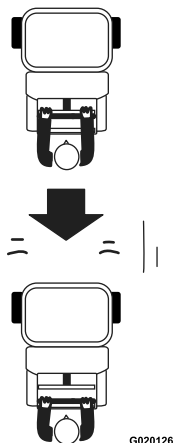

Figure 20

g020126

To turn left or right, move the steering control toward the desired turn direction.

3. To stop the machine, move the motion-control lever to the NEUTRAL position.

**Note:** Stopping distance may vary depending on the spreader-sprayer load.

## Operating the Spreader

### ⚠ CAUTION

Chemicals are hazardous and can cause personal injury.

- Read the chemical manufacturer's directions on the label before handling the chemicals; follow all manufacturer recommendations and precautions.
- Keep chemicals away from your skin. Should contact occur, wash the affected area thoroughly with soap and clean water.
- Wear eye protection, gloves, and any other protective equipment recommended by the chemical manufacturer.

Use the spreader to disperse free-flowing granular substances such as grass seed, fertilizer, ice melt, etc. When you use the spreader, first fill the granular hopper, then apply the granular materials to the work site, and finally clean the hopper.

**Important:** When you use your spreader, thoroughly clean it at the end of the day.

## Before Operating the Spreader

Before you start using the spreader, calibrate the spreader for the material that you will disperse; refer to [Calibrating the Spreader \(page 23\)](#).

**Important:** Prior to filling the hopper, verify that you have set the proper spreader-application rate.

## Calibrating the Spreader

Calibrate the spreader each time you use a new material. The spreader broadcasts material in a pattern 1.5 to 6.7 m (5 to 22 ft) wide depending on the material particle size, volume/density, rate of travel, and wind conditions.

Use the [Spreading Charts \(page 29\)](#) along with information from [Determining the Distribution Pattern \(page 24\)](#), [Determining the Effective Spreading Width \(page 25\)](#), and [Calculating the Application Rate \(page 25\)](#) when calibrating the spreader.

## Preparing the Test Site and Machine

**Operator supplied equipment:** 15 shallow collection pans and 15 graduated measuring cylinders

**Note:** The most accurate method to measure the distribution uses shallow collection pans and graduated measuring cylinders. In the example below, the 15 shallow collection pans approximately 30 cm (12 inches) wide, 91 cm (36 inches) long, and 5 cm (2 inches) tall.

1. Place one pan in the center of the drive path. Arrange the next two pans, one on each side, far enough apart to allow adequate room for the drive tires of the machine to pass around the center pan.
2. Place the remaining pans in a straight line as shown in [Figure 21](#) or [Figure 22](#).
  - For larger granule materials:  
Space 6 additional pans, on each side, 12 inches (30 cm) apart ([Figure 21](#)).

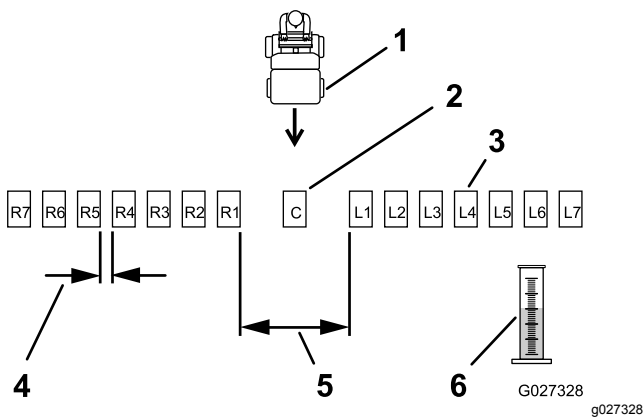

**Figure 21**

Pan spacing for larger granule materials

- |                                       |   |
|---------------------------------------|---|
| 1. Spreader moving toward pans        | 4. L1 and R1 collection pan gap (spread apart to allow machine to pass through) |
| 2. Center pan                         | 5. 30 cm (12 inch) gap  |
| 3. Collection pans (gap between each) | 6. Graduated measuring cylinder   |

- For small granule materials:

Place 6 additional pans, on each side, with no gap in between each pan (Figure 22).

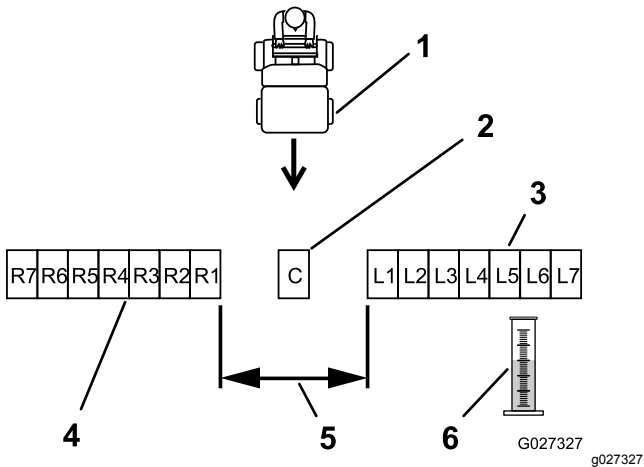

**Figure 22**

Pan spacing for small granule materials

- |   |   |
|---|---|
| 1. Spreader moving toward pans                | 4. Right collection pans (no gap between each)                                  |
| 2. Center collection pan                      | 5. L1 and R1 collection pan gap (spread apart to allow machine to pass through) |
| 3. Left collection pans (no gap between each) | 6. Graduated measuring cylinder   |

- Move the machine far enough away from the test area (where the collection pans are located) to ensure that the machine travels at the desired spreading speed before reaching the site.

- Determine the application rate and the related drop-rate cam setting; refer to [Spreading Charts](#) (page 29).
- Rotate the drop rate cam (Figure 23) to the cam setting you determined in step 4.

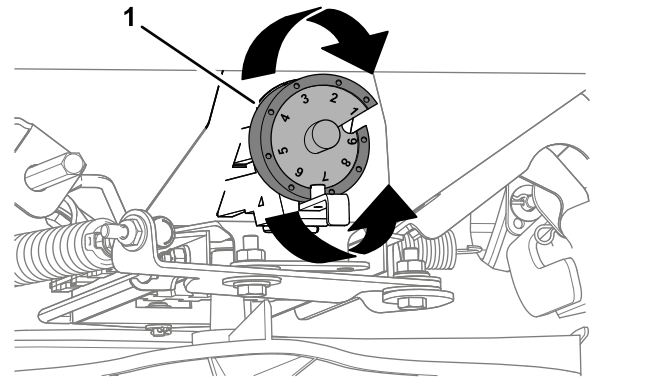

**Figure 23**

- Drop rate cam

- Fill the hopper approximately half-full with the desired material; refer to [Filling the Spreader Hopper](#) (page 26).

### Determining the Distribution Pattern

- Set the spreader pattern control to the middle of its travel; refer to .
- Set the impeller speed to the appropriate broadcasting rate.
- Drive the machine toward the test site at the appropriate speed.
- As you approach the center pan, pull the wide distribution granular gate control to the open position, and drive over the center pan.
- Close the gate control, move motion-control lever to the NEUTRAL position, shut off the engine, wait for all moving parts to stop, remove key, and engage parking brake.
- Label each graduated measuring cylinder to correspond with the distribution pans (such as L2, L1, Center, R1, R2); refer to [Figure 21](#) and [Figure 22](#).
- One at a time, take a collection pan and dump the contents into the corresponding graduated cylinder. Record the amount of material collected and return the pan to its location. Repeat this until all pan contents have been emptied.

**Note:** Repeat broadcasting over the test site several times, moving in the same direction each time, until enough material is dispensed to the collection pan to half fill a graduated cylinder.



8. With the graduated measuring cylinder in the same straight line as the pans, evaluate the volume of material in each cylinder to determine the quality of the distribution from the spreader.
9. To adjust the spreader pattern, refer to the [Adjusting the Spreader Pattern \(page 30\)](#).
10. Fill the hopper half-full of the desired material and repeat steps 1 through 9 until you achieve a uniform pattern.

### Determining the Effective Spreading Width

Use the effective width to determine the uniform distribution of the material.

**Note:** The spreading width range is 6 to 8 m (20 to 25 ft).

1. After the spreader pattern is correctly adjusted, evaluate the amount of material in the center graduated measuring cylinder.
2. Locate the 2 graduated cylinder, one each side of center, that contain 1/2 the measured amount of the material that you observed in the center graduated cylinder.
3. Go to the two corresponding pans. Starting from the outer edge, measure the distance between left pan, across the center pan, to the outer edge of the right pan, and record the measurement.

**Record the effective spreading width here:**\_\_\_\_\_.

### Preparing the Calibration Course for Calculating the Application Rate

1. Determine a course length by dividing 93 m<sup>2</sup> (1,000 ft<sup>2</sup>) by the effective spread width that you determined in [Determining the Effective Spreading Width \(page 25\)](#); use the course length formula. **Record the course length here:**\_\_\_\_\_.

### Calibration Course Length Formula

$$\text{Formula} \quad \frac{93 \text{ m}^2(1,000 \text{ ft}^2)}{\text{Effective width measurement}} = \text{Calibration course length}$$

$$\text{Example} \quad \frac{93 \text{ m}^2(1,000 \text{ ft}^2)}{1.8 \text{ m} (6 \text{ ft})} = 51 \text{ m} (167 \text{ ft})$$

**Note:** In this example the effective width measures 1.8 m (6 ft).

2. Measure and visibly mark the course length. Ensure that you allow enough distance before the starting marker so that the spreader moving forward at full speed when crossing the first mark of the course.

### Calculating the Application Rate

1. Determine the area and amount of material that you are applying to the job site and record those amounts in the area and materials worksheet.

**Record the job site area here:**\_\_\_\_\_.

**Record the amount of job site material here:**\_\_\_\_\_.

2. Initially, use the recommended application rate indicated in the [Spreading Charts \(page 29\)](#) section or use the rate recommended listed on the product manufacturer's label as a guide to help determine the amount of material that you would spread over a 93 m<sup>2</sup> (1,000 ft<sup>2</sup>) area.

**Note:** In this example the calibration course is 1.8 m (6 ft) by 51m (167 ft).

3. Set the appropriate drop-rate cam setting; refer to the [Spreading Charts \(page 29\)](#) as a starting point.
4. Add material to the hopper.

**Note:** In this example we added 11.3 kg (25 lb) of material.

5. Drive the spreader over the calibration course while applying the material.
6. Empty the remaining material of the hopper into a clean bucket; refer to [Emptying the Spreader \(page 26\)](#).
7. Weigh the bucket containing the material and record the weight. Pour the contents back into the hopper and then weigh the empty bucket. Calculate the remaining material weight using the remaining material weight formula. **Record the remaining material weight here:**\_\_\_\_\_.

### Remaining Material Weight Formula

$$\text{Formula} \quad \begin{matrix} \text{(Remaining} \\ \text{material and} \\ \text{bucket weight)} - \\ \text{(Bucket weight)} \end{matrix} = \text{Remaining material weight}$$

$$\text{Example} \quad \begin{matrix} 10 \text{ kg} (22 \text{ lb}) \\ - \\ 1 \text{ kg} (2 \text{ lb}) \end{matrix} = 9 \text{ kg} (20 \text{ lb})$$

**Note:** In this example, 9 kg (20 lb) of material remain in the hopper after applying the material to the test course.

8. Calculate applied material weight using the applied material formula that follows. **Record the applied material weight here:**\_\_\_\_\_.

## Applied Material Weight Formula

$$\text{Formula} \quad \begin{array}{r} \text{(Original} \\ \text{material weight)} \\ - \text{(Remaining} \\ \text{material weight)} \end{array} = \text{Applied material} \\ \text{weight}$$

$$\text{Example} \quad \begin{array}{r} 11.3 \text{ kg (25 lb)} \\ - 9 \text{ kg (20 lb)} \\ \hline 2.3 \text{ kg (5 lb)} \end{array} = 2.3 \text{ kg (5 lb)}$$

3

**Note:** This calculation means that 2.3 kg (5 lb) of material was applied to the 93 m<sup>2</sup> (1,000 ft<sup>2</sup>) test course.

- If necessary, adjust the drop-rate cam to achieve the recommended application rate. Once you achieve the correct application rate, repeat this procedure an additional time to verify your results.

**Important:** Designate a new calibration course each time, so that the turf is not damaged by excessive application of material.

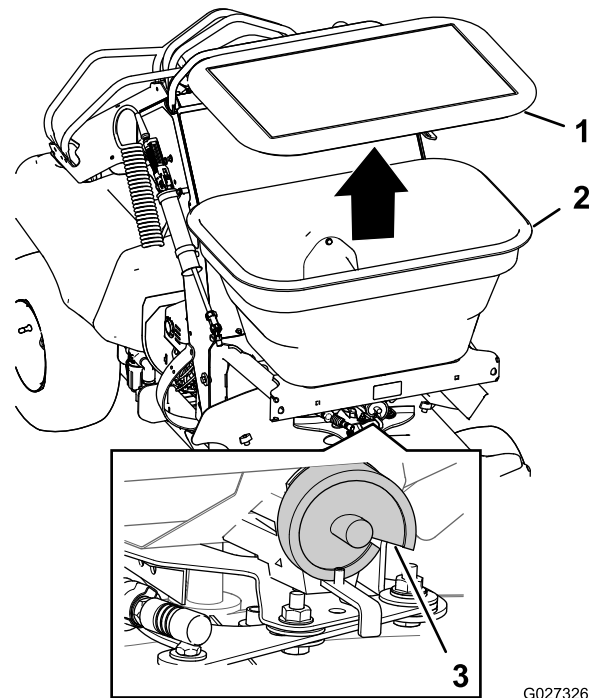

Figure 24

G027326 g027326

- Cover
- Hopper
- Drop-rate cam

## Filling the Spreader Hopper

**Maximum hopper weight capacity:** 79 kg (175 lb)

- Drive the machine to the work site.
- Move the machine to a level surface, move motion-control lever to the NEUTRAL position, shut off the engine, wait for all moving parts to stop, remove key, and engage parking brake.
- Ensure that the wide-distribution impeller-gate lever is in the fully forward (closed) position; refer to [Wide-distribution Impeller-Gate Lever \(page 13\)](#).
- Use the [Spreading Charts \(page 29\)](#) to determine the setting for the drop-rate cam ([Figure 24](#)).

**Note:** If the setting is not listed for the type of material that you are using, set the cam to the setting with a lower value then adjust as needed.

- Remove the cover from the hopper, add the material that you are spreading, and install the cover onto the hopper ([Figure 24](#)).

**Note:** Do not overload the hopper; the maximum weight capacity of the hopper is 79 kg (175 lb).

**Note:** You may place 1 extra bag of granular product on top of the sprayer tank if necessary.

## Emptying the Spreader

### Removing the Impeller

- Move the machine to a level surface, move motion-control lever to the NEUTRAL position, shut off the engine, wait for all moving parts to stop, remove key, and engage parking brake.
- Empty the hopper by scooping out as much of the material as possible.
- Remove the 4 thumbscrews that secure the front cover ( below the impeller) to the chassis, and remove the cover ([Figure 25](#)).

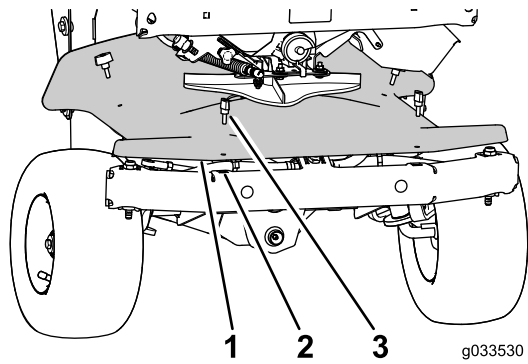

**Figure 25**

1. Forward cover
2. Clip nut
3. Thumb screw

4. Remove the drive pin that secure the impeller to the shaft of the impeller motor, and remove the impeller from the shaft (Figure 26 and Figure 27).

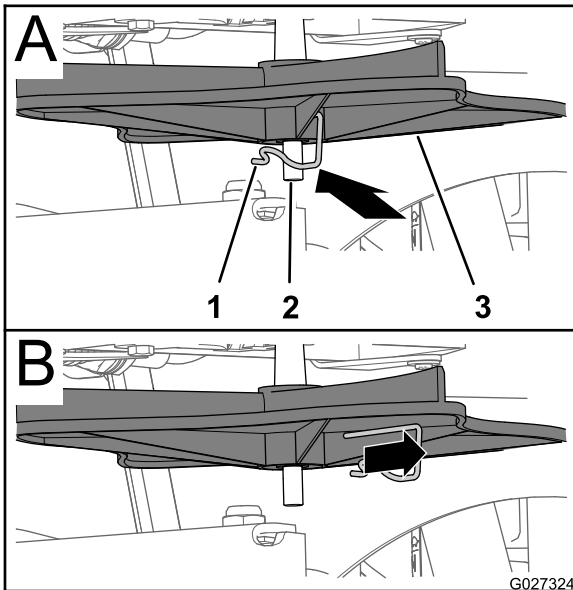

**Figure 26**

1. Drive pin
2. Shaft
3. Impeller

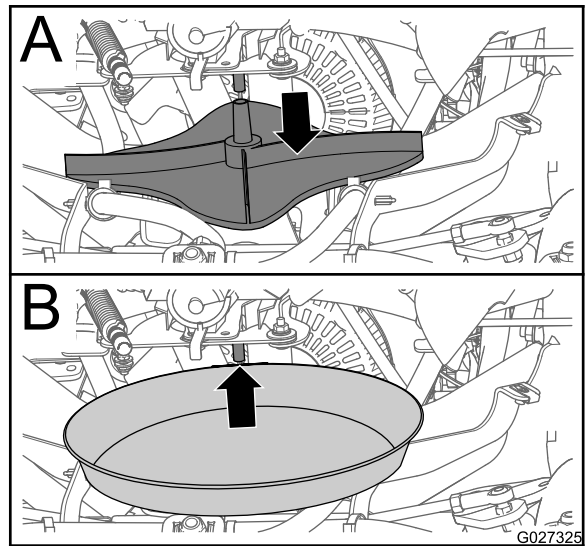
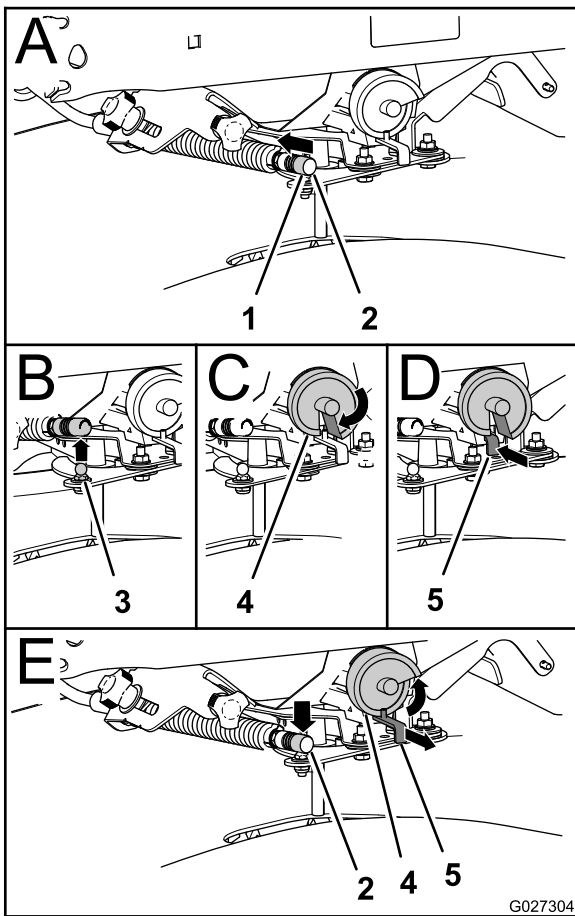

**Figure 27**

5. Place a shallow pan under the shaft of the impeller motor (Figure 27).

### Disconnecting the Rate-Gate Linkage

1. Push the locking sleeve for the gate cable rearward and lift the cable up from the ball stud of the rate-gate linkage (Figure 28).



**Figure 28**

g027304

- |                   |                      |
|-------------------|----------------------|
| 1. Locking sleeve | 4. Drop-rate cam     |
| 2. Gate cable     | 5. Rate-gate linkage |
| 3. Ball stud      |                      |

2. Pull the cable off the ball stud ([Figure 28](#)).
3. Rotate the drop-rate cam past position-9 so that the slot in the cam aligns with the linkage ([Figure 28](#)).
4. Fully push the rate-gate linkage rearward ([Figure 28](#)).
5. If there is material in the hopper allow the material to pour into a shallow pan; when the hopper is empty, remove the pan.

## Connecting the Rate-Gate Linkage

1. Pull the linkage out until it clears the drop-rate cam ([Figure 28](#)).
2. Move the wide-distribution impeller-gate lever forward.
3. Attaching the cable to the ball stud at the gate lever([Figure 28](#)).

## Assembling the Impeller

1. Assemble impeller onto the impeller shaft and secure the impeller with the drive pin.
2. Align the holes in the front cover with the clip nuts in the chassis and secure the cover with the 4 thumbscrews that you removed in step 3 of [Removing the Impeller \(page 26\)](#).

# Using the Spreader

## Spreading Charts

**Note:** The cam setting tables for pellet material and the grass seed are provided with permission from the Brinly-Hardy Company; reference the Brinly-Hardy Company website for more information.

Use these charts as an approximate guideline only. Other factors, such as weather conditions, spreader operation, and the condition of material affects spreader performance.

### Cam Settings for Pellet Material Application

Type	kg per 93 m <sup>2</sup> (lb per 1,000 ft <sup>2</sup> )	Cam Setting — One Pass	Cam Setting — Two Passes
Fine Pellets	0.5 (1)	3.6	3.1
	0.9 (2)	4.0	3.5
	1.4 (3)	4.2	3.7
Mixed Fine Pellets	0.9 (2)	3.7	3.2
	1.8 (4)	4.7	4.1
	2.7 (6)	5.2	4.5
Small Pellets	0.9 (2)	3	2.2
	1.8 (4)	4.2	3.7
	2.7 (6)	4.5	4
Nitrogen Pellets Medium Size	0.5 (1)	3.5	3
	0.9 (2)	4.2	3.7
	1.4 (3)	4.7	4
Medium Pellets and Granules	0.9 (2)	3.5	3
	1.8 (4)	4.2	3.8
	2.7 (6)	5.2	4.5
Large Heavy Pellets	0.9 (2)	3.8	3.3
	1.8 (4)	4.9	4.1
	2.7 (6)	5.9	4.9

Use the chart below for reference only. When spraying and spreading at the same time, set the spread pattern to twice the width of the spray; this will help avoid striping and streaking. For example, standard spray width = 2.7 m (9 ft) and spread width = 5.4 m (18 ft).

### Cam Settings for Grass Seed Application

Type	Bag Weight	Coverage - m <sup>2</sup> (ft <sup>2</sup> )	Cam Setting – Full Rate	Cam Setting – Half Rate	Spreader Width
Blue Grass or Red Top	0.23 kg (0.5 lb)	93 (1,000)	1.25		4
	0.45 kg (1 lb)	93 (1,000)	2.0		4
	0.9 kg (2 lb)	93 (1,000)	2.5		4
Park, Merion, Delta, or Kentucky Bluegrass	2.27 kg (.5 lb)	93 (1,000)	2.5		4
	0.45 kg (1 lb)	93 (1,000)	3.0		4
	0.9 kg (2 lb)	93 (1,000)	3.5		4
Hulled Bermuda	0.9 kg (2 lb)	93 (1,000)	2.75	2.25	6
	1.36 kg (3 lb)	93 (1,000)	3.0	2.5	6
	1.81 kg (4 lb)	93 (1,000)	3.25	2.75	6

## Cam Settings for Grass Seed Application (cont'd.)

Type	Bag Weight	Coverage - m <sup>2</sup> (ft <sup>2</sup> )	Cam Setting – Full Rate	Cam Setting – Half Rate	Spreader Width
Mixtures Including Coarse Seeds	0.9 kg (2 lb)	93 (1,000)	6.0		6
	1.81 kg (4 lb)	93 (1,000)	7.0		6
	2.72 kg (6 lb)	93 (1,000)	7.0		6
Rye Grasses or Tall Fescue	0.9 kg (2 lb)	93 (1,000)	6.0		6
	1.81 kg (4 lb)	93 (1,000)	7.0		6
	2.72 kg (6 lb)	93 (1,000)	7.75		6
Dichondra	113 g (4 oz)	93 (1,000)	1.9		8
	227 g (8 oz)	93 (1,000)	2.1		8
	340 g (12 oz)	93 (1,000)	2.5		8
Pensacola Bahia	1.81 kg (4 lb)	93 (1,000)	4.5	3.75	7
	2.27 kg (.5 lb)	93 (1,000)	4.75	4.0	7
	2.72 kg (6 lb)	93 (1,000)	5.0	4.25	7

### Adjusting the Spreader Pattern

If the spreader casts material unequally side-to-side—too light/heavy to one side—(see [Figure 29](#) and [Figure 30](#)), adjust the spreader-pattern.

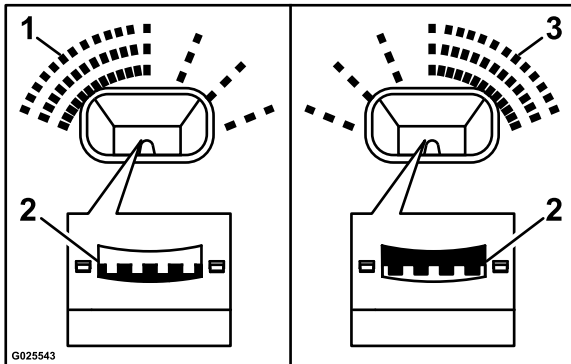

Figure 29

1. Heavy to left side
2. Move ramp pattern to shaded position
3. Heavy to right side

**Note:** Do not adjust the ramps that split the product flow. Adjust only the front or rear ramp positions.

1. Unlock the spreader-pattern control by turning the handle counterclockwise 90° as shown in 2 of [Figure 30](#).

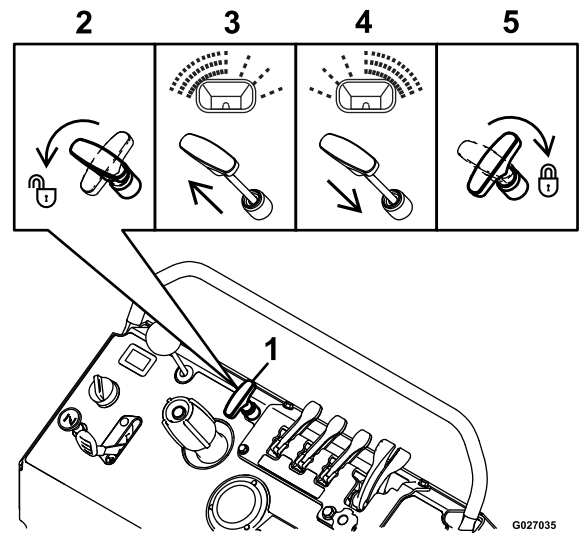

Figure 30

1. Spreader-pattern control
2. Rotate counterclockwise to unlock
3. Start notch if pattern is heavy to left side
4. Start notch if pattern is heavy to right side
5. Rotate clockwise to lock

2. Adjust the spreader pattern as follows:

- If the material is broadcast too heavy at the left side of the machine, pull the spreader-pattern control up slightly; refer to 3 of [Figure 30](#).
- If the material is broadcast too heavy at the right side of the machine, push the spreader-pattern control down slightly; refer to 4 of [Figure 30](#).

- Lock the spreader-pattern control by turning the handle clockwise 90°; refer to 5 of [Figure 30](#).

### Using the Deflector Gate

Use the deflector-gate control to temporarily stop or deflect granular material away from sidewalks, parking lots, patios, or anywhere the granular chemicals are not desired.

**Note:** The deflector gate changes the discharged of materials from the left side of the spreader only.

- Push the knob for the deflector-gate control down to lower the deflector and temporarily block the granular material.
- Pull the knob to raise the deflector to cast materials normally at the left side of the machine.

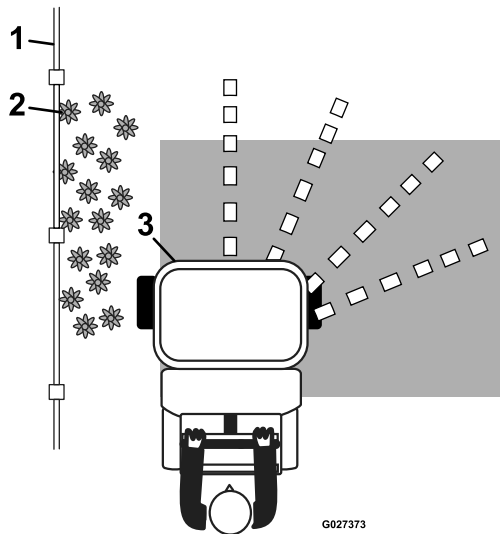
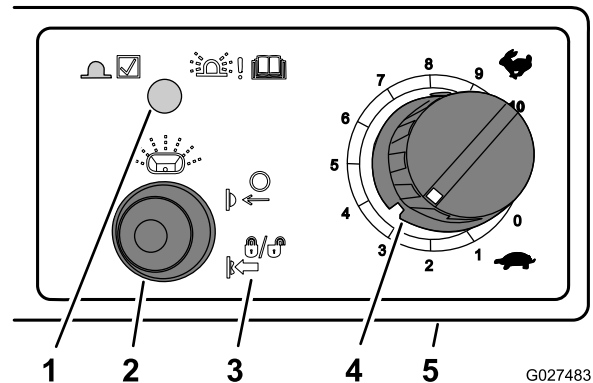

**Figure 31**

- Fence
- Flowers
- Deflector gate lowered

### Spreading Material

- Start the engine and place the throttle midway between the SLOW and the FAST positions.
- Set the impeller-speed control to appropriate broadcast rate and then press the impeller On/Off switch to the ON position ([Figure 32](#)).



**Figure 32**

- Indicator light
- Impeller On/Off switch
- Icon—press and hold the impeller On/Off button 5 seconds
- Impeller-speed control
- Spreader-motor and sprayer-motor controller

- To lock the impeller speed control, press and hold the impeller On/Off switch for 5 seconds ([Figure 32](#)).

**Note:** The indicator light above the impeller On/Off switch will flash at a constant rate. If the impeller-speed control is locked (indicated by the flashing indicator light), the impeller motor will start and run at the last locked speed.

- To unlock the impeller-speed control, start the impeller motor and then press and hold press and hold the On/Off switch for 5 seconds (the indicator light will illuminate steadily).

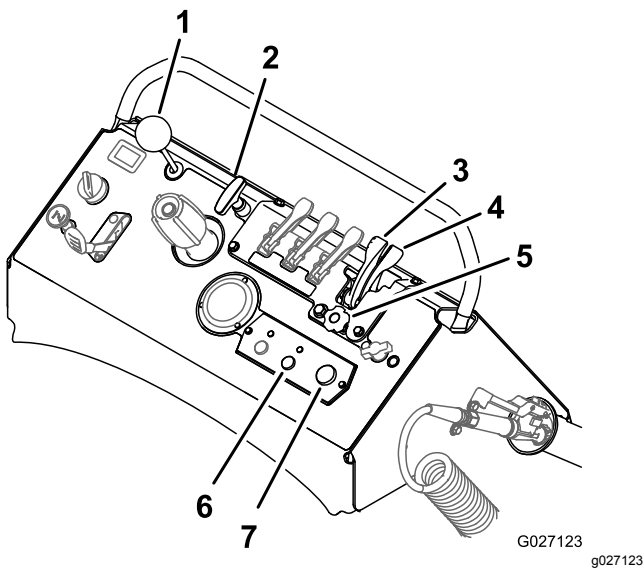
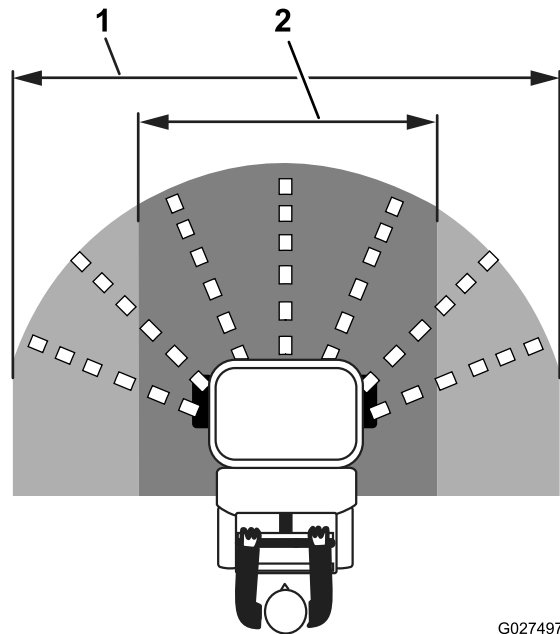

**Figure 33**

- |  |  |
|--|--|
| 1. Deflector-gate control                  | 5. Narrow-spreader distribution flow-rate knob |
| 2. Spreader-pattern control                | 6. Impeller On/Off switch                      |
| 3. Wide-distribution impeller-gate lever   | 7. Impeller-speed control                      |
| 4. Narrow-distribution impeller-gate lever |  |

3. Move the throttle to the FAST position and drive the machine forward.
4. Open the either the narrow or wide impeller-gate lever to begin spreading ([Figure 34](#)).

**Note:** Use the narrow-spreader distribution flow-rate knob to control the discharge rate of the granular material from the hopper onto the impeller when the narrow-distribution impeller-gate lever is in the OPEN position.



**Figure 34**

- |  |   |
|--|---|
| 1. Wide spreader pattern—variable effective width to 6.7 m (22 ft) maximum | 2. Narrow spreader pattern—variable effective width from 1.5 m (5 ft) minimum |
|--|---|

5. Evaluate the spread pattern.

**Note:** If you need to adjustment the spreading pattern, refer to [Adjusting the Spreader Pattern \(page 30\)](#).

6. When you are finished spreading, close the wide-distribution impeller-gate lever.

**Note:** Only the wide-distribution impeller-gate lever closes the impeller gate. Pushing the wide-distribution impeller-gate lever forward also resets the narrow-distribution impeller-gate lever to the forward position.

7. Clean the hopper after each spreading session; refer to [Cleaning and Lubricating the Spreader \(page 43\)](#).

**Important:** Always empty and clean the spreader immediately after each use. Failure to do so may cause the chemicals to corrode the spreader and other components.



## Spreading Tips

**Important:** Ensure that you calibrate the spreader before you start using it.

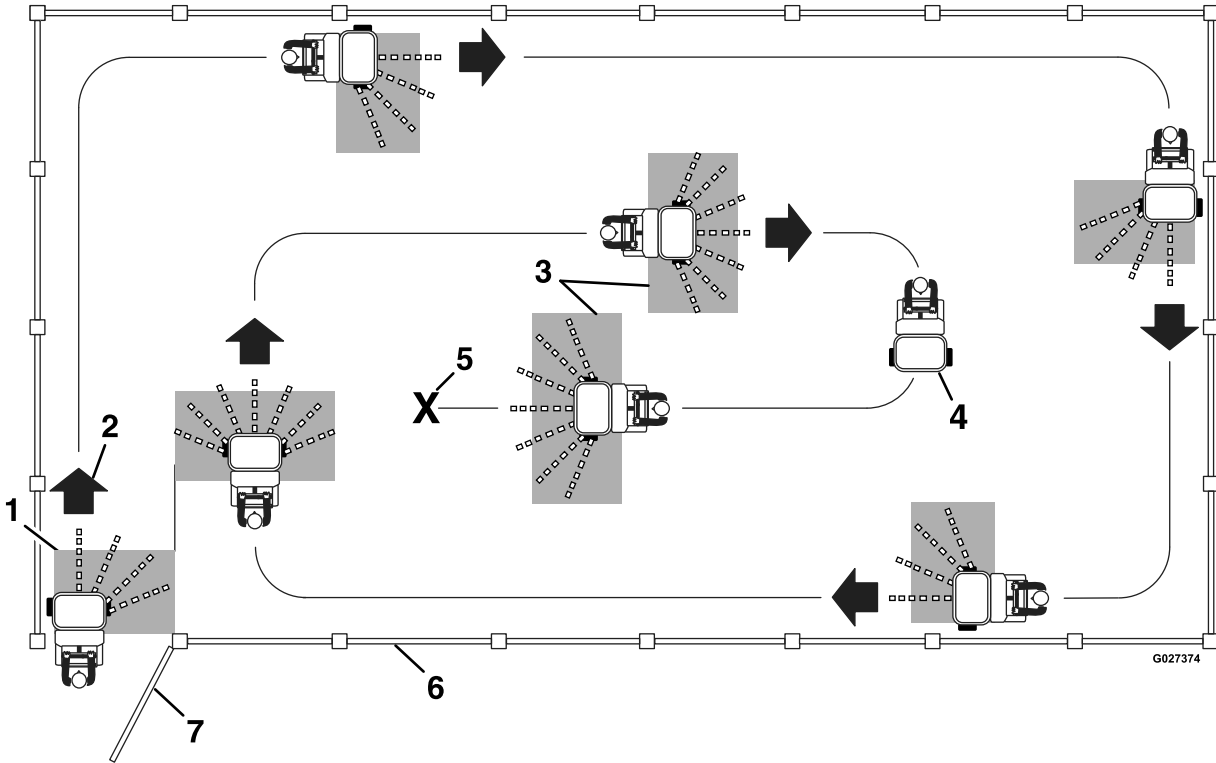

**Figure 35**  
Spreader path example

G027374

1. Narrow distribution-side deflector lowered
2. Forward
3. Effective spreading width—variable 1.5 to 6.7 m (5 to 22 ft)
4. Do not spread when turning 180°
5. End of spreading job
6. Property fence
7. Gate

- To ensure uniform application, broadcast the material in an overlapping pattern as shown in [Figure 35](#).

**Note:** The highest amount of material will dispense from the front of the hopper and less material from each side. You can adjust the distribution pattern to achieve the desired results.

- Watch for changes in the distribution pattern; unequal distribution may lead to striping.

# Operating the Sprayer

## ⚠ CAUTION

Chemicals are hazardous and can cause personal injury.

- Read the chemical manufacture's directions on the label before handling the chemicals; follow all manufacturer recommendations and precautions.
- Keep chemicals away from your skin. Should contact occur, wash the affected area thoroughly with soap and clean water.
- Wear eye protection, gloves, and any other protective equipment recommended by the chemical manufacturer.

Use the sprayer to disperse liquid herbicides, pesticides, fertilizers, and other substances. Before using the sprayer ensure that you have cleaned the tank, plumbing, and nozzles before adding any chemicals. When you use the sprayer, you first fill the spray tank, then apply the chemical solution to the work site, and then when you are finished spraying, clean the tank. It is important to complete all 3 of these steps to avoid damaging the sprayer. For example, Do not mix and add chemicals in the spray tank the night before and then spray in the morning. This could lead to separation of the chemicals and possible cause damage to components of the sprayer.

**Important:** When you use your sprayer, thoroughly clean it at the end of the day.

## Calibrating the Sprayer

**Note:** Before you use the sprayer for the first time or change the nozzles or when the sprayer is out of adjustment—calibrate the sprayer for ground speed and flow rate.

**Note:** The left and right sprayer boom nozzles are wide pattern (white) nozzles and the center nozzle is a narrow pattern (red) nozzle.

**Note:** Refer to the chemical product label for application rate recommendations.

The method to calibrate the sprayer flow involves driving a preset distance, recording the time, and then measuring the amount of liquid applied during that time.

## Calculating the Ground Speed

**Operator supplied equipment:** Stop watch capable of measuring ± 1/10 second.

1. Measure and visibly mark a course length used to calculate the average ground speed. **Record the course length here:**\_\_\_\_\_.

**Note:** In this example the course length is 45.7 m (150 ft).

2. Add clean water into the spray tank until it is 1/2 full; refer to [Filling the Spray Tank \(page 38\)](#).
3. Drive the machine to an area far enough away from the course so that when you are driving it into the course, the machine travels at the desired ground speed before reaching the first marker.
4. Use a stop watch to measure the time (in seconds) that it takes the machine to travel the marked course (45.7 m (150 ft) in this example) while maintaining the desired ground speed. **Record your course time in the course time worksheet.**

## Course Time Worksheet

	Time
Test 1	seconds
Test 2	seconds
Test 3	seconds

5. Repeat steps 2 through 4 an additional 2 times.
6. Move the sprayer to a level surface, move the motion-control lever in the NEUTRAL position, shut off the engine, wait for all moving parts to stop, remove key, and engage parking brake.
7. Average the 3 test run times (in seconds); use the average course time formula. **Record the average course speed here:**\_\_\_\_\_.

## Average Course Time Formula

$$\text{Formula} \quad \frac{(\text{time 1}) + (\text{time 2}) + (\text{time 3})}{3} = \text{The average time to drive the course}$$

$$\text{Example} \quad \frac{21.6 + 19.1 + 18.4 \text{ seconds}}{3} = 19.7 \text{ seconds}$$

8. Calculate the average ground speed; use the ground speed formula. **Record the average ground speed here:**\_\_\_\_\_.

**Note:** 1 kph = 16.6 m/minute (1 mph = 88 ft/minute)

## Ground Speed Formula

$$\text{Formula } \frac{\text{Course length (m (ft) x 60 seconds)}}{\text{Course time (seconds) x 16.7 m/minute (88 ft/minute)}} = \text{Ground speed kph (mph)}$$

$$\text{Example } \frac{45.7 \text{ m (150 ft) x 60 seconds}}{19.7 \text{ seconds x 16.6 m/minute (88 ft/minute)}} = 8.4 \text{ kph (5.2 mph)}$$

## Understanding the Effective Spray Pattern Width

**Note:** Sprayer pressure regulator: 2.8 bar (40 psi).

- The narrow-spray pattern (Figure 36) on the machine is **122 cm (48 inches)** wide.

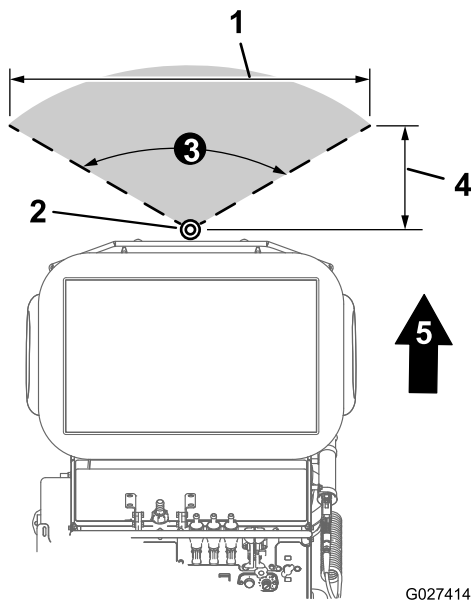
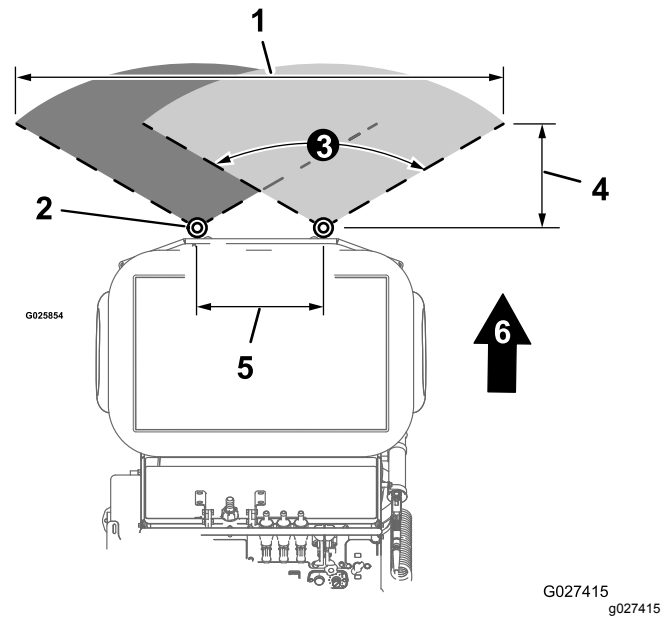

**Figure 36**

Top view of the narrow-pattern-spray nozzle

- Spray width = 122 cm (48 inches)
- Nozzle
- Spray angle = 120°
- Spray distance = 36 cm (14 inches)
- Front of the machine

- The wide-spray pattern (Figure 37) on this machine is **274 cm (108 inches)** wide.



**Figure 37**

Top view of the wide-pattern-spray nozzles

- Spray width = 274 cm (108 inches)
- Nozzle
- Spray angle = 120°
- Spray distance = 61 cm (24 inches)
- Distance between spray nozzles = 66 cm (26 inches)
- Front of the machine

## Testing the Sprayer Nozzle Discharge

**Operator supplied equipment:** Stop watch capable of measuring  $\pm 1/10$  second and a container graduated in 50 ml (1 fl oz) increments.

**Note:** Ensure that the spray system is clean and there is 1/2 tank of clean water.

- Engage the parking brake and start the engine.
- Set the pump/tank agitation switch to the ON position.
- Pull the agitation lever rearward to start the tank agitation.
- Place the throttle to the FAST position.
- Push the agitation control lever down to the OFF position.

**Note:** Shut off the agitation to ensure proper spray pressure and distribution.

- Use the spray-pressure control to adjust the sprayer-system pressure to 40 psi (2.8 bar).

**Note:** The red and white nozzles installed on this sprayer have a normal operating pressure of 40 psi (2.8 bar).

- Align the graduated container under each nozzle for **19.7 seconds**.

**Note:** Record the amount of water collected from each nozzle in the collection worksheet.

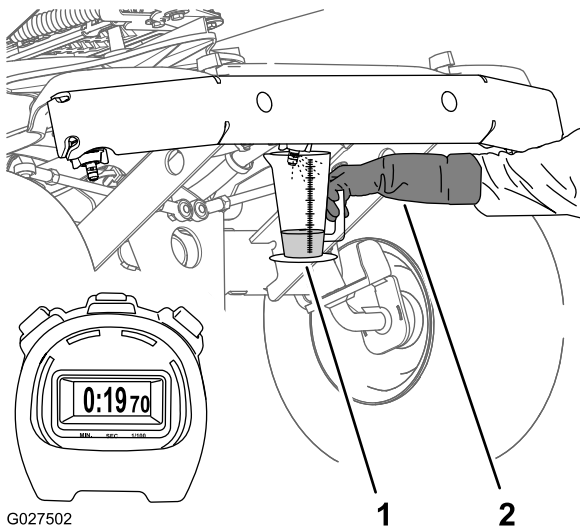

**Figure 38**

1. Graduated container
2. Personal protective equipment—chemical resistant gloves

- **Center nozzle**—record the average discharge quantity here:\_\_\_\_\_.
- **Left nozzle**—record the average discharge quantity here:\_\_\_\_\_.

**Converting the Time and Collection Results to Flow Rate**

1. Convert the milliliters (fluid ounce) quantities that you calculated in step 10 of [Testing the Sprayer Nozzle Discharge \(page 35\)](#) to liters (US gallons) using the quantity conversion formula.

**Note:** 1 L = 1000 ml  
1 US gallon = 128 fl oz

**Quantity Conversion Formula**

$$\text{Formula} \quad \frac{\text{Result (X) ml (fl oz)}}{0.1 \text{ L (128 fl oz)}} = \text{(X) L (US gallon)}$$

**Example** center nozzle—narrow pattern (red)

$$\frac{490 \text{ ml (16.75 fl oz)}}{0.1 \text{ L (128 fl oz)}} = 0.49 \text{ L (0.13 US gallon)}$$

- A. **Right nozzle**—record the converted collected-water quantity here:\_\_\_\_\_.
- B. **Center nozzle**—record the converted collected-water quantity here:\_\_\_\_\_.
- C. **Left nozzle**—record the converted collected-water quantity here:\_\_\_\_\_.

2. Calculate the flow rate of each nozzle using the calculated flow-rate formula.
- 3.

**Calculated Flow-Rate Formula**

$$\text{Formula} \quad \frac{\text{Result (X) L (US gallon)} \times 60 \text{ seconds}}{19.7 \text{ seconds}} = \text{(X) L (US gallon)}$$

**Example** center nozzle—narrow pattern (red)

$$\frac{.49 \text{ L (0.13 US gallon)} \times 60 \text{ seconds}}{19.7 \text{ seconds}} = 3.07 \text{ L (0.40 US gallon) per minute}$$

- A. **Right nozzle**—record the calculated flow rate here:\_\_\_\_\_.
- B. **Center nozzle**—record the calculated flow rate here:\_\_\_\_\_.
- C. **Left nozzle**—record the calculated flow rate here:\_\_\_\_\_.

**Collection Worksheet**

	Left sprayer nozzle	Center sprayer nozzle	Right sprayer nozzle
Test 1	ml (fl oz)	ml (fl oz)	ml (fl oz)
Test 2	ml (fl oz)	ml (fl oz)	ml (fl oz)
Test 3	ml (fl oz)	ml (fl oz)	ml (fl oz)

8. Repeat test step 7 for each nozzle an additional 2 times.
9. Turn off the pump/tank agitation switch.
10. Calculate the average quantity of water discharged for each nozzle; use average discharge formula.

**Average Discharge Formula**

$$\text{Formula} \quad \frac{\text{test 1} + \text{test 2} + \text{test 3}}{3} = \text{The average spray nozzle discharge in 19.7 seconds}$$

**Example** center nozzle—narrow pattern (red)

$$\frac{475 \text{ ml (16.05 fl oz)} + 507 \text{ ml (17.15 fl oz)} + 504 \text{ ml (17.05 fl oz)}}{3} = 0.49 \text{ L (16.75 fl oz)}$$

- **Right nozzle**—record the average discharge quantity here:\_\_\_\_\_.

**Note:** If the collected nozzle spray does not meet the quantity in the [Nozzle Flow Rate Chart \(page 37\)](#), check the nozzles, hoses, and fittings for leaks, damage, or wear; clean or replace the spray nozzles if needed.

### Nozzle Flow Rate Chart

Use the nozzle flow rate charts determine spray nozzle performance:

- Nozzle flow rates at different spray-system pressures
- Worn or damaged spray nozzles

The following chart is based on the nozzle capacity information chart provided with permission from TeeJet® Technologies. Use the chart below or reference the TeeJet® Technologies website to determine if the flow rate of the sprayer nozzle is within the specified flow rate (+/- 10%).

**Note:** The chart information below is based on the machine spraying water at 70°F (21°C).

### Center Nozzle (red—narrow pattern) Flow Rate Chart

Pressure	Flow Rate—New		Flow Rate—In Service Nozzle
0.7 bar (10 psi)	769 ml (26 fl oz) /min	0.76 L (0.20 US gallon) /min	0.68 to 0.75 L (0.18 to 0.22 US gallon) /min
1.4 bar (20 psi)	1065 ml (36 fl oz) /min	1.06 L (0.28 US gallon) /min	0.95 to 1.17 L (0.25 to 0.31 US gallon) /min
2.1 bar (30 psi)	1331 ml (45 fl oz) /min	1.32 L (0.35 US gallon) /min	1.19 to 1.45 L (0.32 to 0.39 US gallon) /min
2.8 bar (40 psi)	1508 ml (51 fl oz) /min	1.51 L (0.40 US gallon) /min	1.36 to 1.66 L (0.36 to 0.44 US gallon) /min

### Left and Right Nozzles (white—wide pattern) Flow Rate Chart

Pressure	Flow Rate—New		Flow Rate—In Service Nozzle
0.7 bar (10 psi)	1508 ml (51 fl oz) /min	1.51 L (0.40 US gallon) /min	1.36 to 1.66 L (0.36 to 0.44 US gallon) /min
1.4 bar (20 psi)	2159 ml (73 fl oz) /min	2.16 L (0.57 US gallon) /min	1.94 to 2.38 L (0.51 to 0.63 US gallon) /min

### Left and Right Nozzles (white—wide pattern) Flow Rate Chart (cont'd.)

2.1 bar (30 psi)	2602 ml (88 fl oz) /min	2.61 L (0.69 US gallon) /min	2.35 to 2.87 L (0.62 to 0.76 US gallon) /min
2.8 bar (40 psi)	3017 ml (102 fl oz) /min	3.03 L (0.80 US gallon) /min	2.73 to 3.33 L (0.72 to 0.88 US gallon) /min

### Determining Application Rate

Use the example results of the calculated speed, spray width, and nozzle capacity to determine the application rate.

**Note:** The application rate may also be determined by using the [Nozzle Flow Rate Chart \(page 37\)](#), along with the chemical manufacturer's label of recommendation.

The examples below are based on the following information:

- Average ground speed = 8.4 kph (5.2 mph)
- Spray width = 2.7 m (108 inches)
- Number of nozzles = 2
- Nozzle capacity = 3.0 L/min (0.8 gpm)

**Note:** The numbers 6 and 600 are constants used in the formulas shown below.

### Liter per 100 m<sup>2</sup> Application Rate

$$\frac{\text{Single nozzle capacity (Lpm)} \times \text{Number of nozzles} \times 6}{\text{Speed (kph)} \times \text{Spray width (m)}} = \frac{\text{L}}{100 \text{ m}^2}$$

$$\frac{2.99 \text{ Lpm} \times 2 \times 6}{8.369 \text{ kph} \times 2.743 \text{ m}} = \frac{1.563 \text{ L/100 m}^2 (1.5 \text{ qt/1,000 ft}^2)}{}$$

### Liter per Hectar Application Rate

$$\frac{\text{Single nozzle capacity (Lpm)} \times \text{Number of nozzles} \times 600}{\text{Speed (kph)} \times \text{Spray width (m)}} = \frac{\text{L}}{\text{hectar}}$$

$$\frac{2.99 \text{ Lpm} \times 2 \times 600}{8.369 \text{ kph} \times 2.743 \text{ m}} = \frac{156 \text{ L/hectar} (16.7 \text{ gal/acre})}{}$$

**Note:** The numbers 544; 136; and 5,940 are constants used in the formulas shown below.

## Quart per 1,000 ft<sup>2</sup> Application Rate

$$\frac{\text{Single nozzle capacity (gpm) x Number of nozzles x 544}}{\text{Speed (mph) x Spray width (inches)}} = \frac{\text{qt}}{1,000 \text{ ft}^2}$$

$$\frac{0.79 \text{ gpm} \times 2 \times 544}{5.2 \text{ mph} \times 108 \text{ inches}} = \frac{1.5 \text{ qt/1,000 ft}^2}{(1.5 \text{ L/100 macre}^2)}$$

## Gallon per 1,000 ft<sup>2</sup> Application Rate

$$\frac{\text{Single nozzle capacity (gpm) x Number of nozzles x 136}}{\text{Speed (mph) x Spray width (inches)}} = \frac{\text{gal}}{1,000 \text{ ft}^2}$$

$$\frac{0.79 \text{ gpm} \times 2 \times 136}{5.2 \text{ mph} \times 108 \text{ inches}} = \frac{0.38 \text{ gal/1,000 ft}^2}{(1.5 \text{ L/100 m}^2)}$$

## Gallon per Acre Application Rate

$$\frac{\text{Single nozzle capacity (gpm) x Number of nozzles x 5,940}}{\text{Speed (mph) x Spray width (inches)}} = \frac{\text{gal}}{\text{acre}}$$

$$\frac{0.79 \text{ gpm} \times 2 \times 5,940}{5.2 \text{ mph} \times 108 \text{ inches}} = \frac{16.7 \text{ gal/acre}}{(156.1 \text{ L/ha})}$$

## Using the Sprayer

### Before Operating the Sprayer

Some chemicals are more aggressive than others and each chemical interacts differently with various materials. Some consistencies of sprayer chemicals (e.g. wettable powders, charcoal) are more abrasive and lead to higher-wear rates. If a chemical is available in a formulation that would provide increased life to the sprayer, use this alternative formulation.

Calibrate the sprayer before you start the spray application; refer to [Calibrating the Sprayer \(page 34\)](#).

### Filling the Spray Tank

**Important:** Ensure that the chemicals that you are using in the sprayer are compatible for use with O-rings and seals made from fluoroelastomer material (refer to the chemical manufacturer's label; it should indicate if it is not compatible). If you use a chemical that is not compatible with

fluoroelastomer material, the O-rings and seals in the sprayer can degrade and leak.

**Important:** Before applying chemicals to the job site, verify that you have set the proper application rate prior to filling the tank.

1. Move the machine to a level surface, move motion-control lever to the NEUTRAL position, shut off the engine, wait for all moving parts to stop, remove key, and engage parking brake.
2. Ensure that the narrow-spray pattern and wide-spray pattern levers are in the OFF position and the handle for the drain valve for the tank rotated 90° counterclockwise to the is CLOSED position ([Figure 39](#)).

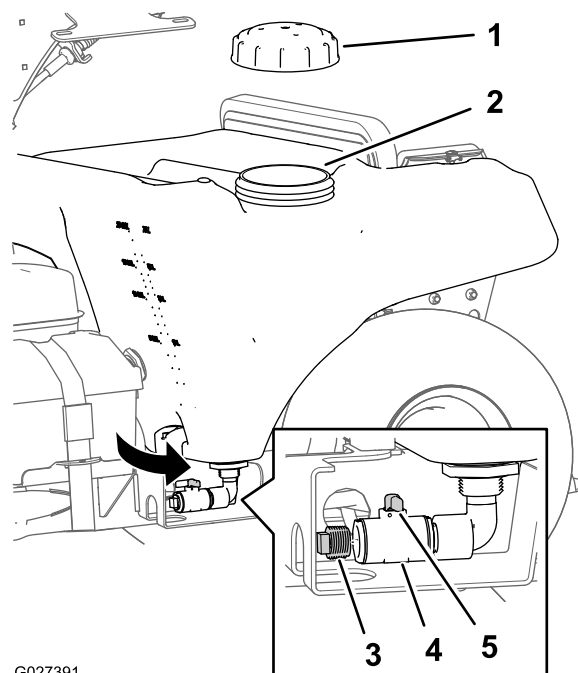

G027391

g027391

**Figure 39**

- |                     |                 |
|---------------------|-----------------|
| 1. Sprayer-tank cap | 4. Drain valve  |
| 2. Filler neck      | 5. Valve handle |
| 3. Plug             |                 |

3. Determine the amount of water needed to mix the amount of chemical needed as specified by the chemical manufacturer.
4. Open the tank cap on the spray tank ([Figure 39](#)).
5. Add 3/4 of the required water to the sprayer tank through the filler neck.

**Important:** Always use fresh, clean water in the spray tank. Do not pour chemical concentrate into an empty tank.

6. Rotate the pump-shutoff valve clockwise to the OPEN position ([Figure 40](#)).

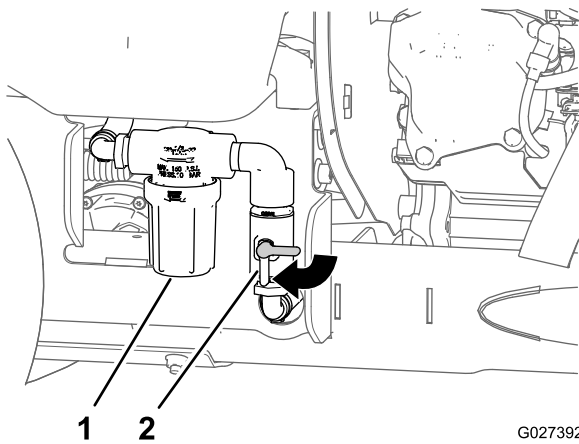

**Figure 40**

1. Strainer (sprayer tank)      2. Pump-shutoff valve

7. Start the engine and set the throttle midway between the SLOW and FAST positions.
8. Set the sprayer-pump switch to the ON position (Figure 41).

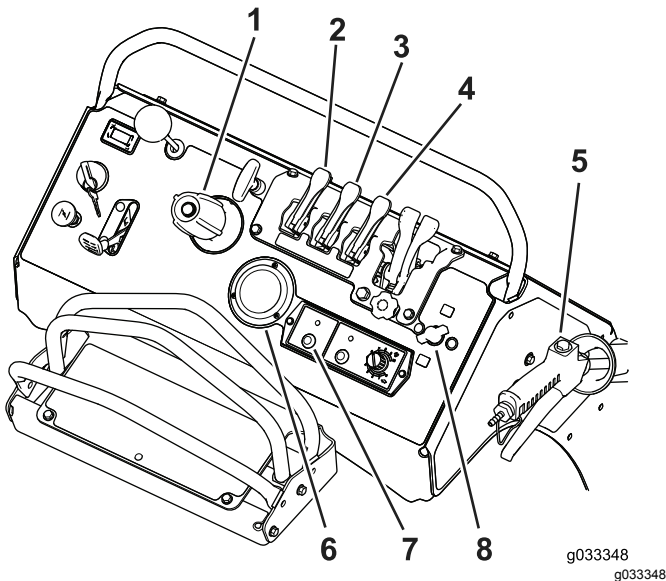

**Figure 41**

- |                               |                                       |
|-------------------------------|---------------------------------------|
| 1. Sprayer-pressure control   | 5. Spray wand                         |
| 2. Agitation-pump lever       | 6. Sprayer-pressure gauge             |
| 3. Narrow-spray pattern lever | 7. Sprayer-pump/tank-agitation switch |
| 4. Wide-spray pattern lever   | 8. Sprayer-wand-pressure control      |

9. Move the throttle to the FAST position.
10. Pull rearward on the tank-agitation lever to the ON position.

**Note:** The water in the tank will circulate.

11. Add the specified amount of chemical concentrate to the tank as directed by the chemical manufacturer.

**Important:** If you are using a wettable-powder chemical, mix the powder with a small amount of water to form a liquid slurry before adding the chemical mixture to the tank.

12. Add remaining water to the tank and install cap onto the filler neck of the tank.

**Note:** Allow the content of the sprayer tank to mix thoroughly.

## Emptying the Sprayer Tank

### Operator supplied equipment:

- A drain hose with a 1/2–14 inch NPT male coupling
  - A drain container (capacity varies with remaining sprayer tank content)
  - PTFE thread sealant
1. Move the machine to a level surface at the designated area for emptying and cleaning the sprayer tank, move motion-control lever to the NEUTRAL position, shut off the engine, wait for all moving parts to stop, remove key, and engage parking brake.
  2. Remove the plug from the drain valve for the sprayer tank (Figure 42).

**Note:** The drain valve is located at the left side of the machine.

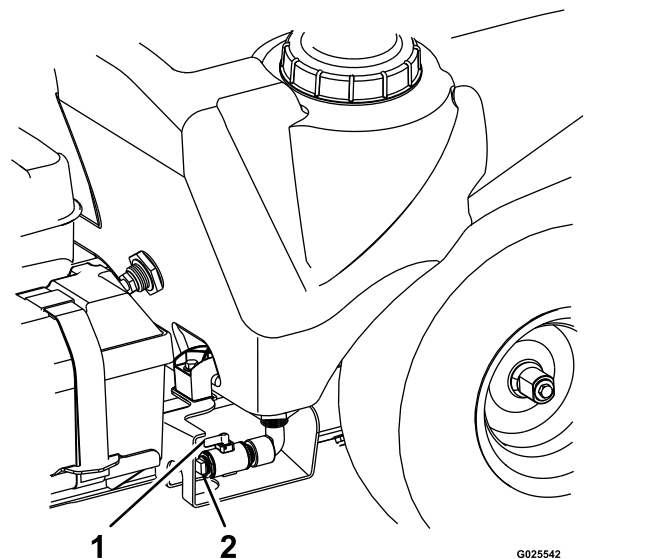

**Figure 42**

1. Drain valve
  2. Plug
3. Thread a drain hose (operator provided) into the end of the drain valve.
  4. Put the free end of the drain hose into a container with enough capacity to hold the remaining content of the sprayer tank.

**Note:** Use the quantity marks at the front, left side of the sprayer tank for determine the quantity of chemical solution in the tank.

5. Rotate the handle for the drain valve clockwise 90° to drain the tank (Figure 42).

Allow the sprayer tank to drain completely.

6. Apply PTFE thread sealant to the threads of the plug.
7. Close the tank-drain valve, remove the drain hose, and install the drain plug into the valve (Figure 42).

**Note:** Dispose of the sprayer chemicals according to local codes and the chemical manufacturer's instructions.

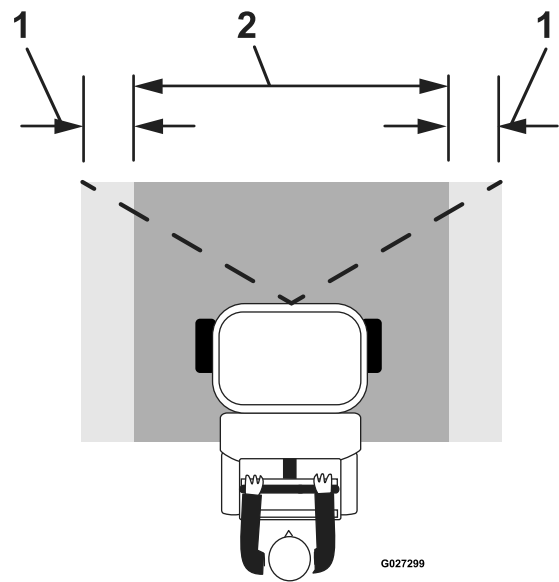

**Figure 43**  
Narrow-spray pattern

1. Overlap area
2. Effective spray area

## Spraying with the Sprayer Boom

**Important:** To ensure that your chemical solution remains well mixed, use the agitation feature whenever you have solution in the tank. For the agitation feature to work, set the sprayer-pump switch to the ON position, pull back the tank-agitation lever, and run the engine at high idle. If you shut off the machine and agitation is needed, leave the motion-control lever in the NEUTRAL position, engage the parking brake, increase the throttle to the FAST position, switch on the pump and set agitation lever.

**Note:** Calibrate the sprayer before you start the spray application; refer to [Calibrating the Sprayer \(page 34\)](#).

1. Set the sprayer-pump switch to the ON position.
2. Drive the machine to the job site.
3. Push forward the tank-agitation lever to the OFF position.

**Note:** There is some agitation effect even while the tank-agitation lever is in the OFF position.

4. Adjust the sprayer-pressure control to the setting that you determined in [Calibrating the Sprayer \(page 34\)](#).
5. Move the narrow or wide-spray pattern lever to the ON position and begin spraying.

**Important:** Do not use both the narrow and wide controls at the same time.

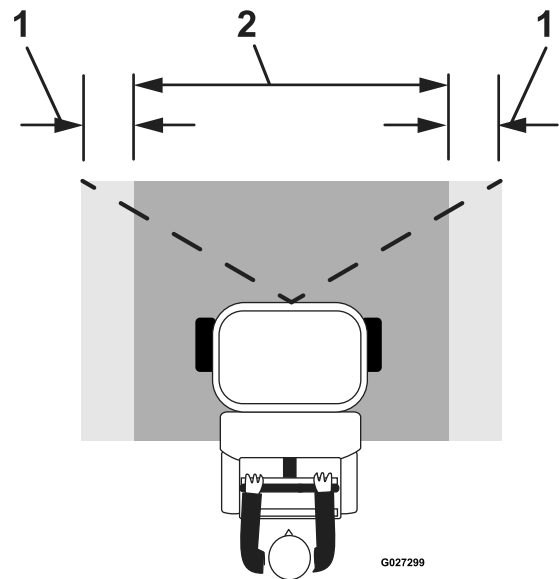

**Figure 44**  
Wide-spray pattern

1. Overlap area
2. Effective spray area

6. When you finish spraying, push forward the spray-pattern levers and set the sprayer-pump switch to the OFF position.

**Note:** If you need to continue to mix the sprayer tank contents, leave the sprayer-pump switch in the ON position and pull back the tank-agitation lever.



## Spraying Tips

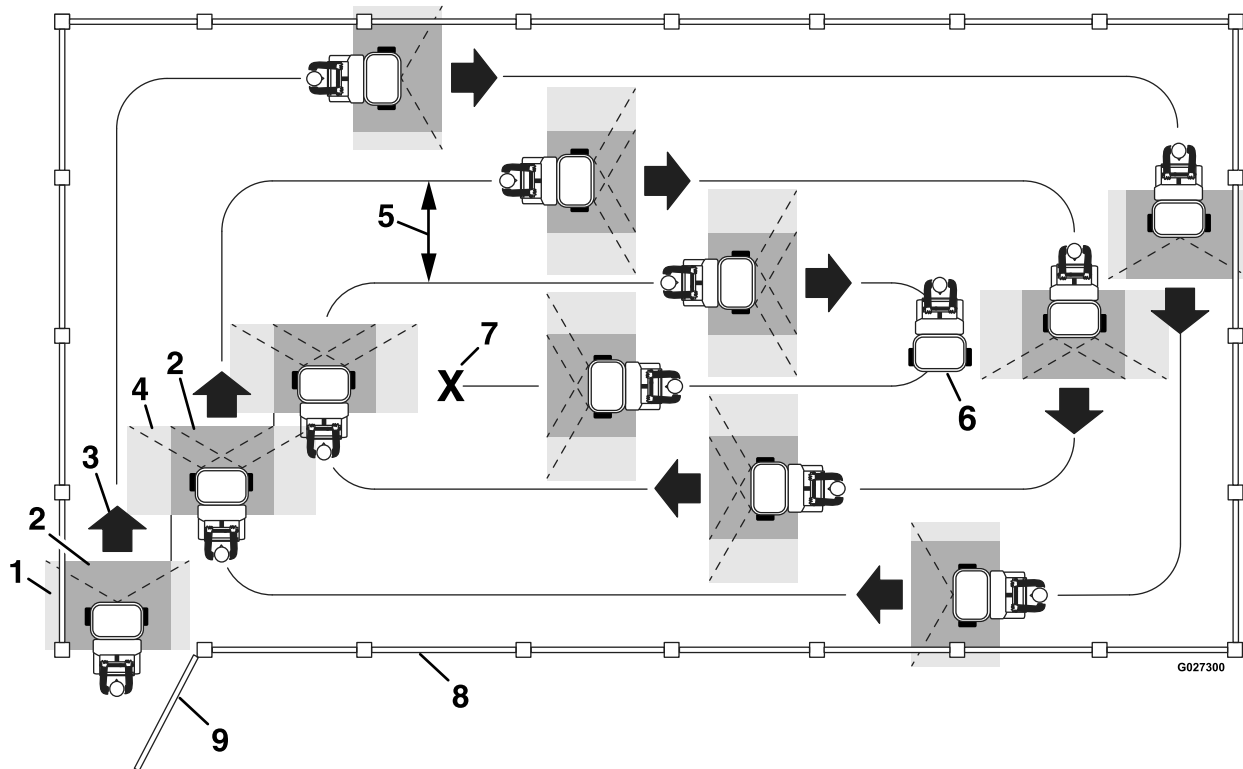

Figure 45

g027300

- |  |   |
|--|---|
| <ul style="list-style-type: none"> <li>1. Overlap area—narrow spray pattern</li> <li>2. Effective spray area</li> <li>3. Forward</li> <li>4. Overlap area—wide spray pattern</li> <li>5. 2.4 m (8 ft)</li> </ul> | <ul style="list-style-type: none"> <li>6. Sprayer Off—do not spray when turning the machine 180°</li> <li>7. End of spraying job</li> <li>8. Property fence</li> <li>9. Gate</li> </ul> |
|--|---|

- Do not overlap the effective spray area that you have previously sprayed (see [Figure 45](#)).
- Watch for plugged sprayer nozzles.
- Move the narrow-and wide-spray pattern levers to the OFF position to stop the spray flow before stopping the motion of the machine. Once stopped, leave the motion-control lever in NEUTRAL and leave the sprayer-pump switch in the ON position.
- You obtain better results if the machine is moving when spray controls are turned ON.
- Ensure adequate pump pressure for proper spray distribution by push forward the tank-agitation lever to the OFF position.
- Watch for changes in the application rate. Changes in the application rate indicate that your ground speed has changed beyond the operating range of the nozzles or there is a problem with the sprayer system.

agitation lever to the OFF position. Alternatively, if an anti-foaming agent compatible with the existing chemical—add the anti-foaming agent according to the manufacturer's instructions.

**Note:** When the tank is nearly empty, the tank agitation may cause foaming of the chemical solution in the tank. In this case, push forward the tank

# Spraying with the Spray Wand

## ⚠ WARNING

The spray wand traps liquids under high pressure, even when engine is off. High-pressure spray discharge could cause serious injury or death.

- Keep clear of the nozzle and do not direct the spray or stream from the wand at people, pets, or non-work area property.
- Do not direct the spray at or near electrical-power components or source.
- Do not repair the spray wand, hoses, seals, nozzle, or other wand components; always replace them.
- Do not attach the hoses or other components to the nozzle at the end of the spray wand.
- Do not attempt to disconnect the spray wand from the machine while the sprayer system is pressurized.
- Do not use the spray wand if trigger lock is damaged or missing.
- Rotate the spray-wand lock to the OFF position when job is complete.

1. Remove the wand from the holder at the right side of the machine (Figure 46).

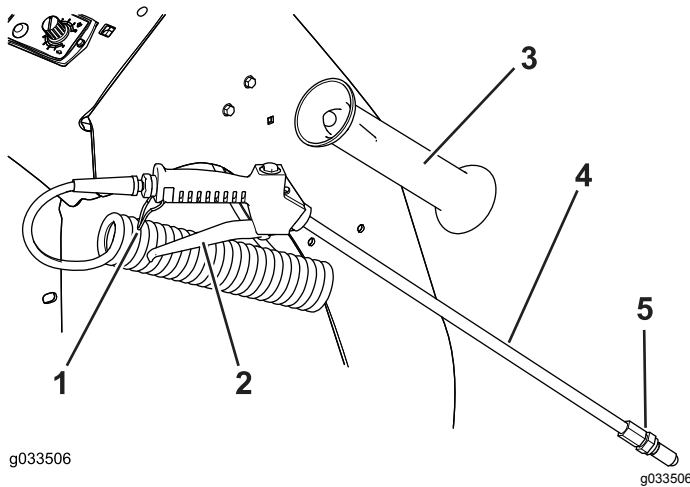

Figure 46

- |                 |           |
|-----------------|-----------|
| 1. Wand holder  | 4. Wand   |
| 2. Trigger      | 5. Nozzle |
| 3. Trigger lock |           |

2. Firmly grip the spray wand and point it in the direction that you will spray.

**Note:** The wand may recoil; ensure that you hold it securely.

3. Adjust the pump pressure to the spray wand perform the following:

- To increase the pump pressure to the wand, rotate the wand-pressure control counterclockwise (Figure 47).

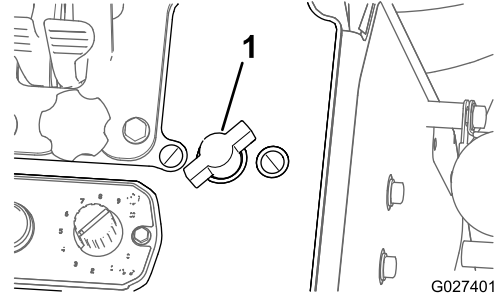

Figure 47

1. Sprayer wand pressure control

- To decrease pressure to the wand, rotate the control clockwise direction (Figure 47).
- To shut off the pressure to the wand, rotate the wand-pressure control clockwise until the valve for the control is closed (Figure 47).

4. Squeeze the trigger to the spray-wand handle to begin spraying; lock the trigger in place if desired (Figure 46).
5. When finished spraying, if you locked the trigger of the spray-wand—unlock it, and release the trigger (Figure 46)
6. Rotate the sprayer-wand pressure control clockwise to the OFF position (Figure 47).
7. Insert the wand into the wand holder (Figure 46).

# After Operation

## After Operation Safety

### General Safety

- Park the machine on a level surface; shut off the engine; engage the parking brake; remove the key; and wait for all movement to stop before leaving the operator's position.
- After you finish operating the machine for the day, wash off all chemical residue from the outside of the machine; refer to [Chemical Safety \(page 16\)](#).
- Use full-width ramps for loading the machine into a trailer or truck.
- Tie the machine down securely to the trailer or truck using straps, chains, cable, or ropes. Both front and rear straps should be directed down and outward from the machine.
- Shut off the fuel before transporting or storing the machine.
- Keep all parts of the machine in good working condition and all hardware tightened.
- Allow the engine to cool before storing the machine in any enclosure.
- Never store the machine or fuel container where there is an open flame, spark, or pilot light, such as on a water heater or on other appliances.
- Replace any damaged spray wand components; do not attempt to repair hoses, seals, nozzles, or other wand components.

## Cleaning and Lubricating the Spreader

**Service Interval:** After each use

1. Drive the machine to a designated cleaning area with a level surface.
2. Move the motion-control lever in the NEUTRAL position, shut off the engine, wait for all moving parts to stop, remove key, and engage parking brake.
3. Empty the hopper; refer to [Emptying the Spreader \(page 26\)](#).
4. Using a hose to spray the inside and outside of the entire spreader with clean water.

**Note:** Do not use a power washer to clean the machine. The high-pressure water can force residual-corrosive materials into sprayer-spreader components.

5. Tilt the screen at the bottom of the hopper forward to clean the bottom hopper components ([Figure 48](#)).

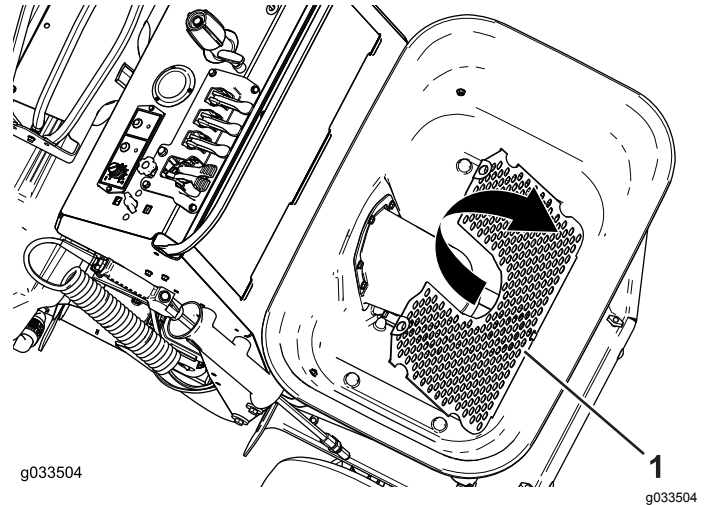

**Figure 48**

1. Hopper screen

6. Rotate the hopper screen down.
7. Disconnect the hopper rate-gate cable, place the rate gate dial to a setting lower than the maximum open position, and allow the spreader-sprayer to empty completely; refer to [Emptying the Spreader \(page 26\)](#).
8. Connect the hopper rate-gate cable; refer to [Connecting the Rate-Gate Linkage \(page 28\)](#).
9. Apply water-displacing lubricant to the components as shown in [Figure 49](#).

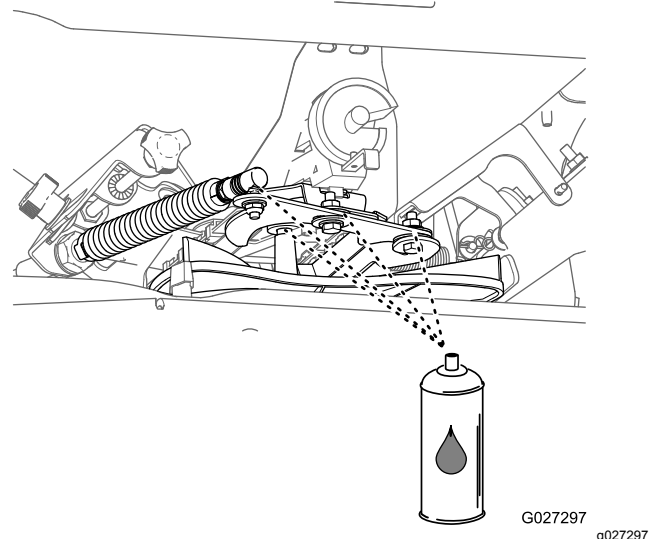

**Figure 49**

# Cleaning the Sprayer

Service Interval: After each use

## ⚠ WARNING

Swallowing or inhaling chemicals could cause serious injury or death.

- Do not clean sprayer nozzles using your mouth or blowing through the nozzles.
- Replace all worn and damaged sprayer nozzles.
- Ensure that the nozzles are installed correctly.

## Preparing the Machine

1. Empty the sprayer tank; refer to [Emptying the Sprayer Tank \(page 39\)](#).
2. Fill the sprayer tank with 19 L (5 US gallons) or more of clean water and install the cap; refer to [Filling the Spray Tank \(page 38\)](#).
3. Engage the parking brake, move the steering-control/motion-control lever to the NEUTRAL position, and start the engine ([Figure 50](#)); refer to [Starting the Engine \(page 21\)](#).

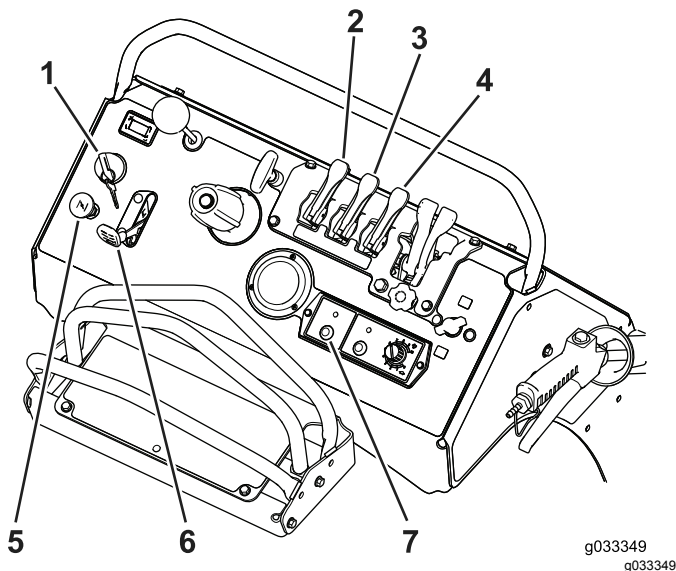

Figure 50

- |                               |                                       |
|-------------------------------|---------------------------------------|
| 1. Ignition switch            | 5. Choke                              |
| 2. Agitation-pump lever       | 6. Throttle                           |
| 3. Narrow-spray pattern lever | 7. Sprayer-pump/tank-agitation switch |
| 4. Wide-spray pattern lever   |                                       |

4. Set the sprayer-pump switch to the ON position, and set the engine throttle to FAST position ([Figure 50](#)).

5. Move the tank-agitation lever to the ON position ([Figure 50](#)).

## Cleaning the Sprayer System and Wand

**Important:** Always empty and clean the sprayer immediately after each use. Failure to do so may cause the chemicals to dry or thicken in the lines, clogging the pump and other components.

1. Pull back both narrow and wide-spray pattern levers to the ON position ([Figure 50](#)).  
The sprayer nozzles begin spraying.
2. Allow the rinse water in the tank to spray through the nozzles.
3. Check that all 3 nozzles are spraying correctly.
4. Remove the sprayer wand from the holder, point the wand in a safe direction, and squeeze the trigger; refer to [Spray-Wand Trigger and Trigger Lock \(page 15\)](#).

**Note:** Allow the rinse water to discharge from the wand for 1 to 2 minutes.

5. Release the trigger for the wand and return it to the holder on the machine ([Figure 7](#)).
6. Move the spray-pattern levers forward to the OFF position, set the sprayer-pump switch to the OFF position, and shut off the engine ([Figure 50](#)).
7. Clean the strainer; refer to [Cleaning the Strainer \(page 45\)](#).
8. Repeat steps 2 through 7 using cleaners and neutralizers recommended by the chemical manufacturers; refer to [Filling the Spray Tank \(page 38\)](#).
9. Repeat steps 2 through 7 using clean water only.

## Cleaning the External Components

1. Using a hose to wash off the outside of the sprayer tank with clean water.

**Note:** Do not use a power washer to clean the machine. The high-pressure water may force residual corrosive materials into spreader-spreader components.

2. Remove and clean the sprayer nozzles; refer to [Cleaning the Sprayer Nozzle \(page 45\)](#).

**Note:** Replace damaged or worn nozzles.

3. Allow the spreader-sprayer to completely dry before the next use.

# Cleaning the Strainer

**Service Interval:** After each use

**Important:** If you used wettable-powder chemicals, clean the strainer after each time that you rinse the sprayer tank.

1. Empty the sprayer tank; refer to [Emptying the Sprayer Tank](#) (page 39).
2. Rotate the handle of the pump-shutoff valve 90° counterclockwise to the CLOSE position ([Figure 51](#)).

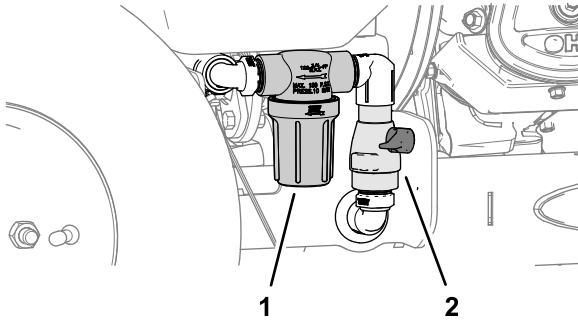

**Figure 51**

g249175

1. Strainer
2. Pump-shutoff valve

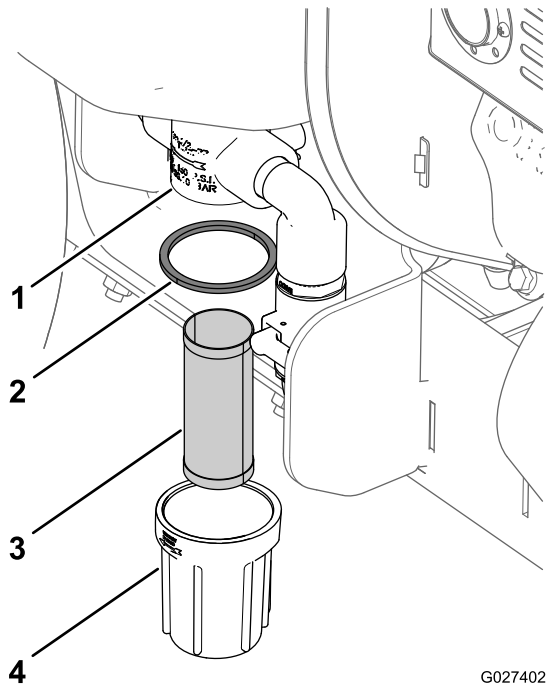

G027402

g027402

**Figure 52**

1. Strainer body
2. Gasket
3. Screen
4. Strainer bowl

3. Align a drain pan under the strainer ([Figure 51](#)).
4. Rotate the strainer bowl counterclockwise and remove the bowl and screen from the body of the strainer ([Figure 52](#)).

**Note:** Remove the strainer bowl by hand.

**Note:** Replace the gasket or screen or both if these parts are worn or damaged

5. Allow any residual chemical solution to drain from the strainer body.
- Note:** Dispose of the waste solution according to local codes and the chemical manufacturer's instructions.
6. Use a soft-bristle brush and clean water to clean the screen and bowl
  7. Install the screen into the strainer body ([Figure 52](#)).
  8. Install the gasket and strainer bowl onto the strainer body, and hand tighten the bowl ([Figure 52](#)).
  9. Rotate the handle of the pump-shutoff valve 90° clockwise to the OPEN position ([Figure 51](#)).

# Cleaning the Sprayer Nozzle

**Service Interval:** After each use

1. Rotate the nozzle cap 90° counterclockwise and remove the cap from the nozzle body ([Figure 53](#)).

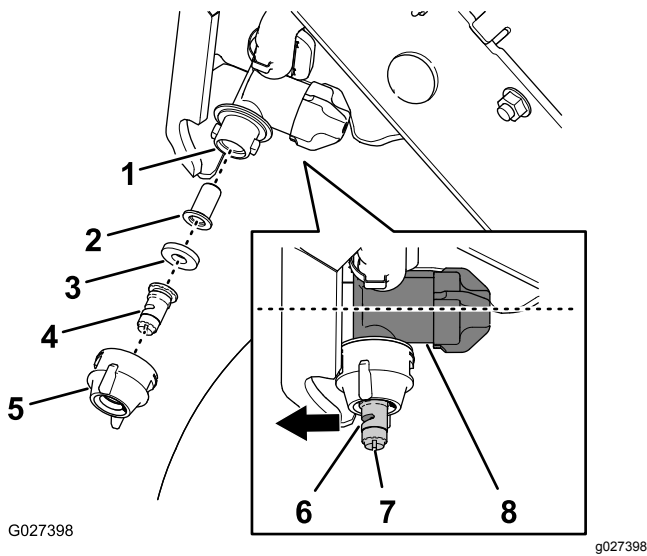

Figure 53

- |                |                   |
|----------------|-------------------|
| 1. Nozzle body | 5. Nozzle cap     |
| 2. Strainer    | 6. Atomizer       |
| 3. Gasket      | 7. Slot           |
| 4. Sprayer tip | 8. Regulator case |

2. Remove the sprayer tip, gasket, and strainer from the nozzle body (Figure 53).
 

**Note:** Replace any worn or damaged nozzle parts.
3. Use a soft-bristle brush and clean water to clean the nozzle tip, gasket, and strainer.
4. Assemble the strainer into the nozzle body (Figure 53).
5. Assemble the sprayer tip and gasket into the nozzle cap (Figure 53).
6. Install the tip, gasket, and cap onto the nozzle body (Figure 53).
 

**Note:** Use the slot to rotate the atomizer (Figure 53) of the sprayer tip forward (in-line with the flow-regulator case of the nozzle body).
7. Rotate the nozzle cap 90° clockwise (Figure 53).
8. Repeat steps 1 through 7 for the 2 other sprayer nozzles.

## Transporting the Machine

**Machine weight:** 227 kg (500 lb)—both sprayer tank and hopper empty; 389 kg (857 lb)—both sprayer tank and hopper full

### ⚠ CAUTION

This machine does not have proper turn signals, lights, reflective markings, or a slow moving vehicle emblem. Driving on a street or roadway without such equipment is dangerous and can lead to accidents causing personal injury. Driving on a street or roadway without such equipment may also be a violation of State laws and the operator may be subject to traffic tickets and/or fines.

**Do not drive a machine on a public street or roadway.**

## Loading the Machine

### ⚠ WARNING

Loading a machine onto a trailer or truck increases the possibility of tip-over and could cause serious injury or death.

- Use extreme caution when operating a machine on a ramp.
- Back the machine up the ramp and walk it forward down the ramp.
- Avoid sudden acceleration or deceleration while driving the machine on a ramp as this could cause a loss of control or a tip-over situation.
- Do not attempt to turn the machine while on the ramp; you may lose control and drive off the side.
- Use only a single, full-width ramp; do not use individual ramps for each side of the machine.
- If individual ramps must be used, use enough ramps to create an unbroken ramp surface wider than the machine.

Use a heavy-duty trailer or truck to transport the machine. Ensure that the trailer or truck has all the necessary brakes, lighting, and marking as required by law. Please carefully read all the safety instructions.

1. If using a trailer, connect it to the towing vehicle and connect the safety chains.
2. If applicable, connect the trailer brakes.
3. Lower the ramp.

4. Raise the operator platform.
5. Back the machine up the ramp ([Figure 54](#)).

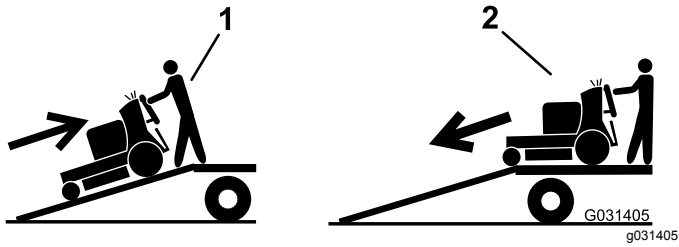

**Figure 54**

1. Back the machine up the ramp.
2. Walk the machine forward down the ramp.

6. Secure the machine; refer to [Securing the Machine for Transport](#) (page 47).

## Securing the Machine for Transport

**Note:** Refer to the chemical-warning-product label(s) before transporting the machine and follow all local/state/federal requirements for transporting chemicals.

**Note:** Ensure that the spreader-hopper cover and the spray wand are secure before transporting.

1. At the left side of the machine, ensure that the shutoff valve for the sprayer tank is closed and the drain plug is secure. At the right side of the machine, ensure that the pump-shutoff valve is closed.
2. Shut off the engine, remove the key, and engage the parking brake.
3. Close the fuel valve and block the tires.
4. Use the tie-down points on the machine to securely bind the machine to the trailer or truck with straps, chains, cable, or ropes ([Figure 55](#)). Refer to local regulations for trailer and tie-down requirements.

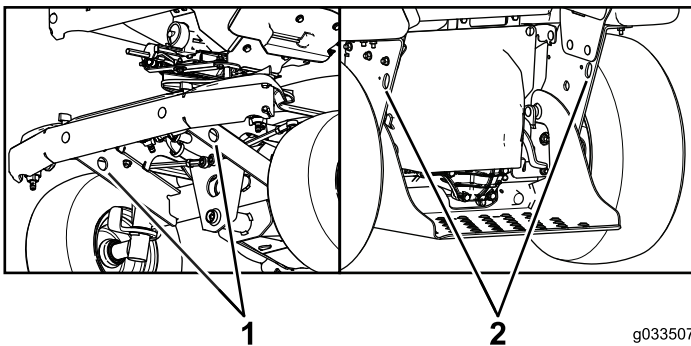

**Figure 55**

1. Front tie-down points
2. Rear tie-down points

# Maintenance

## Maintenance Safety

- Before performing maintenance on the machine; refer to [Preparing the Machine \(page 50\)](#).
- Before performing any maintenance, thoroughly clean and rinse the spreader and sprayer.
- Clean grass and debris from the drives, mufflers, and engine to help prevent fires.
- Allow only qualified and authorized personnel to maintain, repair, adjust, or inspect the machine.
- Do not repair the spray wand, hoses, seals, nozzle, or other wand components; always replace them.
- Mechanical or hydraulic jacks may malfunction, allowing the machine to fall; do not rely solely on mechanical or hydraulic jacks for support. Use adequate jack stands or equivalent support.
- Chemicals used in the sprayer system may be hazardous and toxic to you, bystanders, animals, plants, soils, or other property.
  - Carefully read and follow the chemical warning labels and material safety data sheets (MSDS) for all chemicals used, and protect yourself according to the chemical manufacturer's recommendations.
  - Always protect your skin while you are near chemicals. Use the appropriate personal protective equipment (PPE) to guard against contact with chemicals, including the following:
    - ◇ safety glasses, goggles, and/or face shield
    - ◇ a chemical suit
    - ◇ a respirator or filter mask
    - ◇ chemical-resistant gloves
    - ◇ rubber boots or other substantial footwear
    - ◇ a clean change of clothes, soap, and disposable towels for cleanup
  - Refuse to operate or work on the sprayer if chemical safety information is not available.
  - Do not fill, calibrate, or clean the machine while people, especially children, or pets are in the area.
  - Handle chemicals in a well-ventilated area.
  - Have clean water available, especially when filling the spray tank.
  - Do not eat, drink, or smoke while working near chemicals.
  - Do not clean spray nozzles by blowing through them or placing them in your mouth.
- Always wash your hands and other exposed areas as soon as possible after working with chemicals.
- Chemicals and fumes are dangerous; never enter the tank or place your head over or in the opening of a tank.
- Clean up oil or fuel spills.
- Do not store the machine or fuel near flames or drain the fuel indoors.
- Use jack stands to support the machine and/or components when required.
- Carefully release pressure from components with stored energy.
- Disconnect the battery or remove the spark-plug wire before making any repairs. Disconnect the negative terminal first and the positive terminal last. Connect the positive terminal first and negative last.
- Keep your hands and feet away from moving parts. If possible, do not adjust the machine with the engine running.
- Keep all parts in good working condition and all hardware tightened. Replace all damaged or missing decals.
- Never interfere with the intended function of a safety device or reduce the protection provided by a safety device. Check their proper operation regularly.
- To ensure optimum performance and continued safety certification of the machine, use only genuine Toro replacement parts and accessories. Replacement parts and accessories made by other manufacturers could be dangerous, and such use could void the product warranty.
- Check the parking brake operation frequently. Adjust and service as required.



# Recommended Maintenance Schedule(s)

Maintenance Service Interval	Maintenance Procedure
Before each use or daily	<ul style="list-style-type: none"> <li>• Check the safety interlock system.</li> <li>• Test the starter interlock.</li> <li>• Check air cleaner; replace if dirty. (May need more often under severe conditions.)</li> <li>• Check the engine-oil level.</li> <li>• Check the machine for loose hardware.</li> </ul>
After each use	<ul style="list-style-type: none"> <li>• Clean and lubricate the spreader.</li> <li>• Clean the sprayer tank.</li> <li>• Clean the strainer.</li> <li>• Clean the sprayer nozzles.</li> <li>• Clean the engine and the exhaust system area.</li> <li>• Clean the grass and debris buildup from the machine.</li> </ul>
Every 50 hours	<ul style="list-style-type: none"> <li>• Clean the foam air-cleaner element More often under severe conditions.</li> <li>• Check the pressure in the tires.</li> <li>• Service the transaxle.</li> <li>• Check sprayer system.</li> </ul>
Every 80 hours	<ul style="list-style-type: none"> <li>• Remove the engine shrouds and clean the cooling fins.</li> </ul>
Every 100 hours	<ul style="list-style-type: none"> <li>• Lubricate the grease fittings.</li> <li>• Replace the dual element air filter.</li> <li>• Change the engine oil.</li> <li>• Change the engine oil (more often under severe condition).</li> <li>• Check, clean and gap the spark plug.</li> </ul>
Every 200 hours	<ul style="list-style-type: none"> <li>• Service the spark arrester.</li> </ul>
Monthly	<ul style="list-style-type: none"> <li>• Clean the fuel-sediment cup.</li> <li>• Service the fuel strainer.</li> <li>• Check the battery.</li> </ul>
Yearly	<ul style="list-style-type: none"> <li>• Torque the axle bolts.</li> </ul>
Yearly or before storage	<ul style="list-style-type: none"> <li>• Prepare the machine for storage.</li> </ul>

## Notation for Areas of Concern

Inspection performed by:		
Item	Date	Information
1		
2		
3		
4		
5		
6		
7		
8		

**Important:** Refer to your engine owner's manual for additional maintenance procedures.

# Pre-Maintenance Procedures

## ⚠ CAUTION

If you leave the key in the switch, someone could accidentally start the engine and seriously injure you or other bystanders.

Remove the key from the switch before you perform any maintenance.

## ⚠ CAUTION

Raising the machine for service or maintenance relying solely on mechanical or hydraulic jacks could be dangerous. The mechanical or hydraulic jacks may not be enough support or may malfunction allowing the machine to fall, which could cause injury.

Do not rely solely on mechanical or hydraulic jacks for support. Use adequate jack stands or equivalent support.

## Preparing the Machine

## ⚠ WARNING

While you are maintaining or adjusting the machine, someone could start the engine. Accidentally starting the engine could seriously injure you or other bystanders.

Remove the key from the ignition, engage parking brake, and pull the wire(s) off the spark plug(s) before you do any maintenance. Also push the wire(s) aside so it does not accidentally contact the spark plug(s).

Perform the following before servicing, cleaning, or making any adjustments to the machine.

1. Park the machine on a level surface.
2. Shut the wide-distribution impeller-gate for the spreader and shut off the sprayer-pump switch.
3. Shut off the engine and remove the key.
4. Engage the parking brake.
5. Wait for all moving parts to stop allow the engine to cool before servicing, storing, or making repairs.
6. Disconnect the spark-plug wire ([Figure 56](#)).

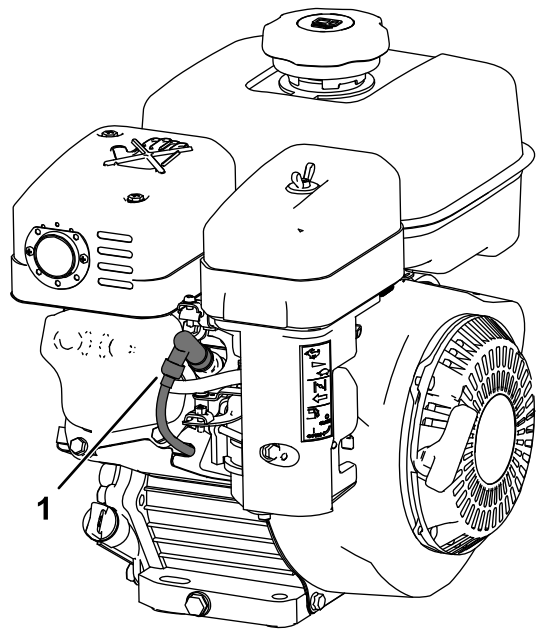

Figure 56

g259487

1. Spark-plug wire

# Lubrication

## Lubricating the Grease Fittings

**Service Interval:** Every 100 hours

**Grease type:** National Lubricating Grease Institute (NLGI) grade #2 multi-purpose gun grease.

1. Prepare the machine for maintenance; refer to [Preparing the Machine \(page 50\)](#).
2. Wipe the grease fittings clean with a rag ([Figure 57](#)).

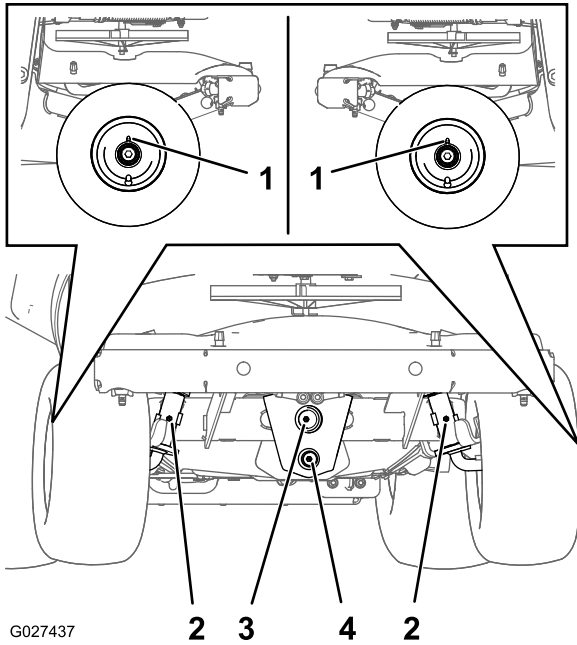

**Figure 57**

- |                       |                           |
|-----------------------|---------------------------|
| 1. Wheel bearings (2) | 3. Front axle pivot       |
| 2. Kingpin pivots (2) | 4. Steering control pivot |

3. Connect a grease gun to the fittings ([Figure 57](#)).
4. Pump grease into the fittings until grease begins to come out of the bearings.
5. Wipe up any excess grease.

# Engine Maintenance

## Servicing the Air Cleaner

**Service Interval:** Before each use or daily  
Every 100 hours

**Important:** Do not apply oil to the foam or paper element.

## Removing the Foam and Paper Elements

1. Prepare the machine for maintenance; refer to [Preparing the Machine \(page 50\)](#).
2. Clean around the air cleaner to prevent dirt from getting into the engine and causing damage ([Figure 58](#)).

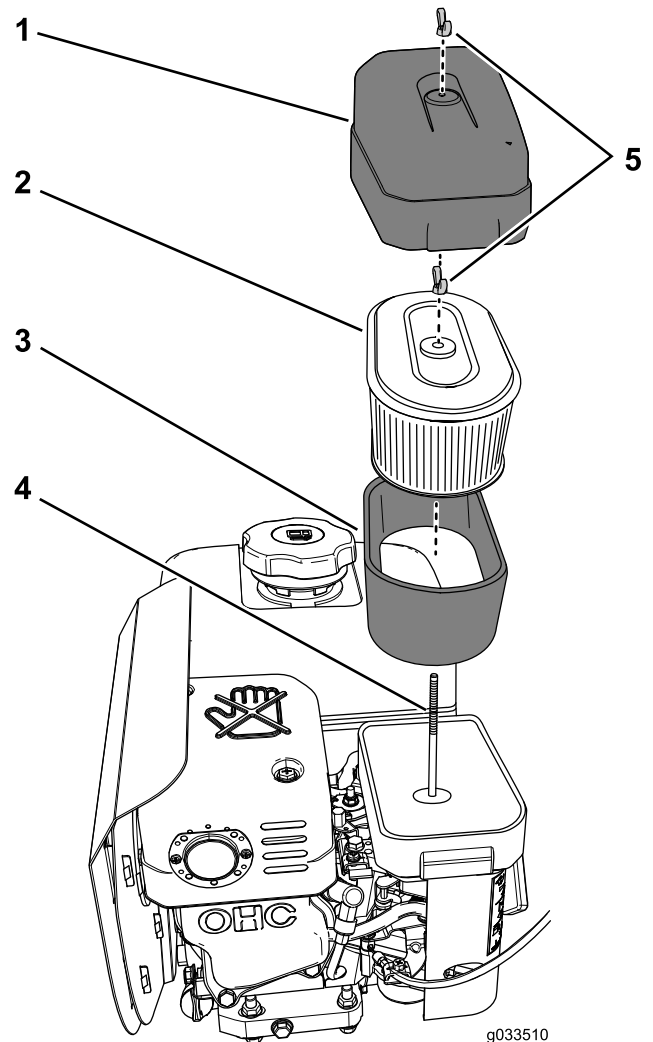

**Figure 58**

- |                         |                  |
|-------------------------|------------------|
| 1. Air-cleaner cover    | 4. Hold-down rod |
| 2. Paper-filter element | 5. Wing nuts     |
| 3. Foam element         |                  |

3. Rotate the wing nut that secures the air-cleaner cover counterclockwise and remove the air-cleaner cover (Figure 58).
4. Rotate the wing nut that secures the paper and foam-filter elements counterclockwise and remove the filter elements from the hold-down rod (Figure 58).
5. Carefully pull the foam element off the paper element (Figure 58).

**Note:** Inspect the paper and foam-filter elements for damage or an excessive accumulation of dirt. Replace the damaged filters. Clean the foam-filter element if it is dirty. Replace the paper-filter element if it is dirty.

## Servicing the Foam Filter Element

**Service Interval:** Every 50 hours More often under severe conditions.

1. Inspect the element for tears, an oily film, or damaged (Figure 58).  
**Important:** Replace the foam element if it is worn or damaged.
2. Wash the foam element in liquid soap and warm water. When the element is clean, rinse it thoroughly.
3. Dry the element by squeezing it in a clean cloth.
4. Air dry the foam-filter element.

## Installing the Foam and Paper-Filter Elements

**Important:** To prevent engine damage, always operate the engine with the complete foam and paper air-cleaner assembly installed.

1. Carefully slide the foam-filter element onto the paper-filter element (Figure 58).
2. Align the hole in the top plate of the paper-filter element with the hold-down rod of the carburetor (Figure 58).
3. Secure the filter elements to the carburetor with the wing nut (Figure 58) that you removed in step 4 of [Removing the Foam and Paper Elements](#) (page 51).
4. Align the hole in the air-cleaner cover with the hold-down rod (Figure 58) and secure the cover to the rod with the wing nut that you removed in step 3 of [Removing the Foam and Paper Elements](#) (page 51).

## Engine Oil Specification

**Oil Type:** Detergent oil (API service SJ or higher)

**Oil viscosity:** Refer to the table below.

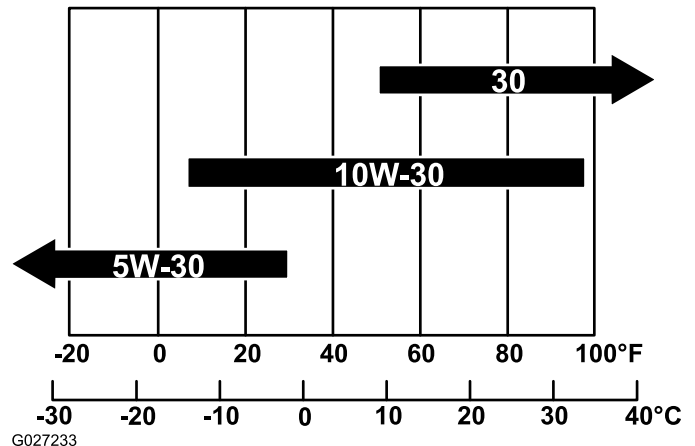

Figure 59

## Checking the Engine-Oil Level

**Service Interval:** Before each use or daily

**Important:** Do not operate the engine with the oil level below the Low (or Add) mark on the dipstick, or over the Full mark.

1. Move the machine to a level surface.
2. Prepare the machine for maintenance; refer to [Preparing the Machine](#) (page 50).
3. Allow the engine to cool.
4. Remove the dipstick from the engine and wipe the dipstick with a clean rag (Figure 60).

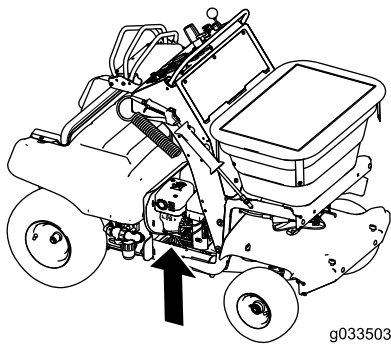

g033503

g033503

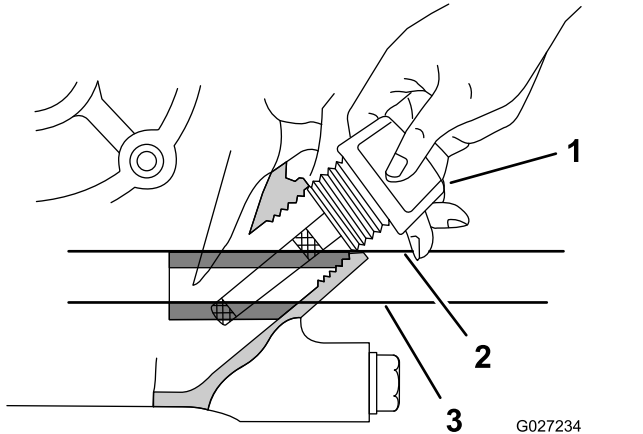

G027234

g027234

**Figure 60**

- 1. Dipstick
- 2. Maximum oil level
- 3. Minimum oil level

- 5. Insert the dipstick from the engine as shown in [Figure 60](#).

**Note:** Do not thread the dipstick into the filler neck when checking the engine oil level.

- 6. Remove the dipstick from the filler neck and look at the oil level in the dipstick ([Figure 60](#)).

**Note:** The engine oil level must cover between the hatch marked areas on the dipstick ([Figure 60](#)).

- 7. If the oil level is low, wipe off the area around the filler neck and add the specified oil until the oil level is between the hatch marked areas on the dipstick.

**Important:** Do not overfill the engine with oil.

- 8. Hand tighten the dipstick into the filler neck ([Figure 60](#)).

# Changing the Engine Oil

**Service Interval:** Every 100 hours

Every 100 hours (more often under severe condition).

## Draining the Engine Oil

**Important:** Do not operate the engine with the oil level below the Low (or Add) mark on the dipstick, or over the Full mark.

- 1. Prepare the machine for maintenance; refer to [Preparing the Machine \(page 50\)](#).
- 2. Align a drain pan with a capacity of 1.5 L (1.6 US qt) or greater below the drain valve at the bottom of the skid plate and inboard from the battery tray ([Figure 61](#)).

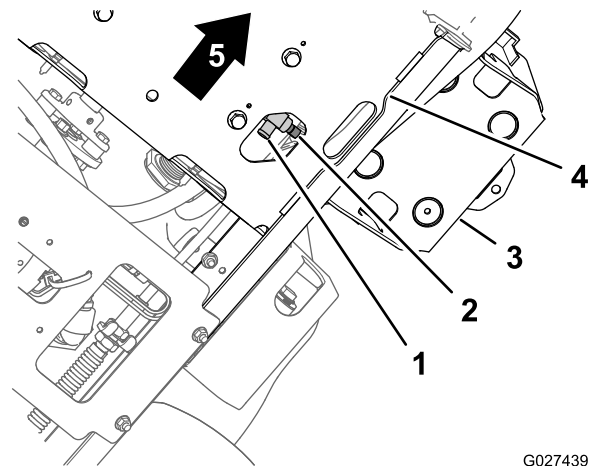

G027439

g027439

**Figure 61**

- 1. Drain valve
- 2. Hex-head stem
- 3. Battery tray
- 4. Skid plate
- 5. Front of the machine

- 3. Open the drain valve by rotating the hex-head stem of the valve counterclockwise with a wrench ([Figure 61](#)).

**Note:** Allow the engine oil to drain completely.

- 4. Close the drain valve clockwise until the valve is fully seated ([Figure 61](#)).

**Note:** Wipe clean any residual oil from the drain valve.

## Adding Engine Oil to the Engine

**Engine Oil Capacity:** 1.1 L (1.2 US qt)

**Important:** Do not operate the engine with the oil level below the Low (or Add) mark on the dipstick, or over the Full mark.

1. Remove the dipstick from the filler neck of the engine and wipe clean the dipstick with a rag (Figure 62).

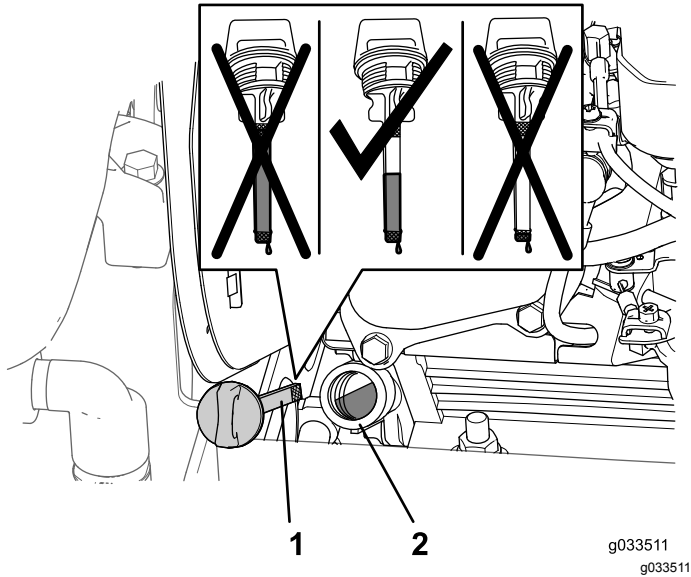

Figure 62

1. Dipstick
2. Filler neck

2. Slowly pour 1.1 L (1.2 US qt) of the specified oil into the crank case of the engine through the filler neck (Figure 62).
3. Insert the dipstick from the engine as shown in Figure 63.

**Note:** Do not thread the dipstick into the filler neck when checking the engine oil level.

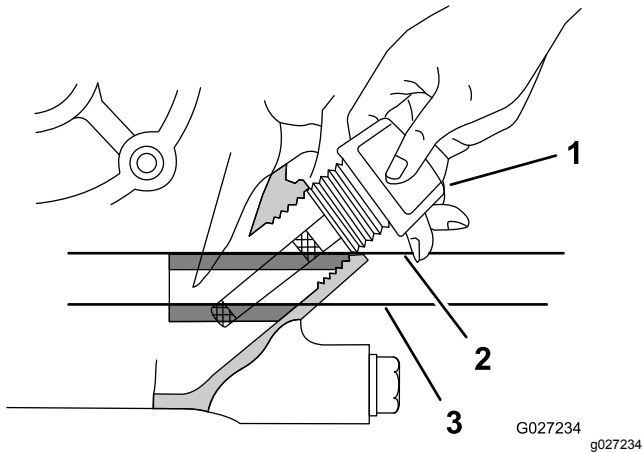

Figure 63

1. Dipstick
2. Maximum oil level
3. Minimum oil level

4. Remove the dipstick from the filler neck and look at the oil level in the dipstick (Figure 62).

**Note:** The engine oil level must cover between the hatch marked areas on the dipstick (Figure 62).

5. If the oil level is low, add the specified oil into the engine until the oil level is between the hatch marked areas on the dipstick.

**Note:** Do not overfill the engine with oil.

6. Hand tighten the dipstick into the filler neck (Figure 62).

## Servicing the Spark Plug

**Service Interval:** Every 100 hours

### Spark Plug Specification

**Spark Plug Type:** NGK BR6HS, Champion RTL86C, or equivalent

### Removing the Spark Plug

1. Prepare the machine for maintenance; refer to [Preparing the Machine \(page 50\)](#).
2. Remove the spark plug as shown in Figure 64.

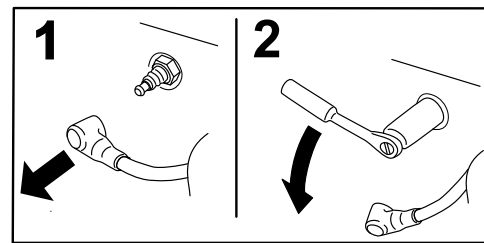
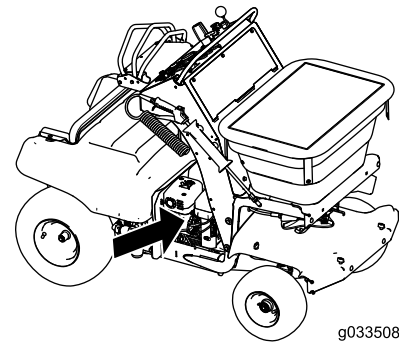

Figure 64

## Checking the Spark Plug

**Air Gap:** 0.6 to 0.7 mm (0.02 to 0.03 inch)

**Important:** Do not clean the spark plug(s). Always replace the spark plug(s) when it has a black coating, worn electrodes, an oily film, or cracks.

If you see light brown or gray on the insulator, the engine is operating properly. A black coating on the insulator usually means the air cleaner is dirty.

Use a gapping tool/feeler gauge to check and adjust the air gap to 0.6 to 0.7 mm (0.02 to 0.03 inch).

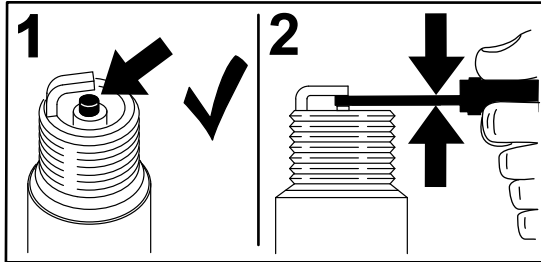

G008794

g008794

Figure 65

## Installing the Spark Plug

Tighten the spark plug as follows:

- New spark plug—12 to 15 N·m (8.7 to 10.8 ft-lb)
- In-service spark plug—23 to 27 N·m (16.6 to 19.5 ft-lb)

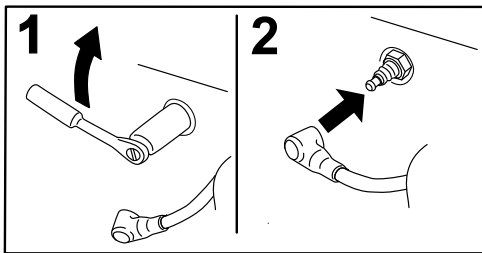

G008795

g008795

Figure 66

## Servicing the Spark Arrester

**Service Interval:** Every 200 hours

### Removing the Spark Arrester

#### **⚠ WARNING**

Hot exhaust system components may ignite gasoline vapors even after the engine is stopped. Hot particles exhausted during engine operation may ignite flammable materials. Fire may result in personal injury or property damage.

Do not refuel or run engine unless spark arrester is installed.

1. Prepare the machine for maintenance; refer to [Preparing the Machine \(page 50\)](#).
2. Allow the muffler to cool.
3. Remove the 2 self-tapping screws that secure the tail screen to the muffler cover and remove the screen ([Figure 68](#) and [Figure 68](#)).

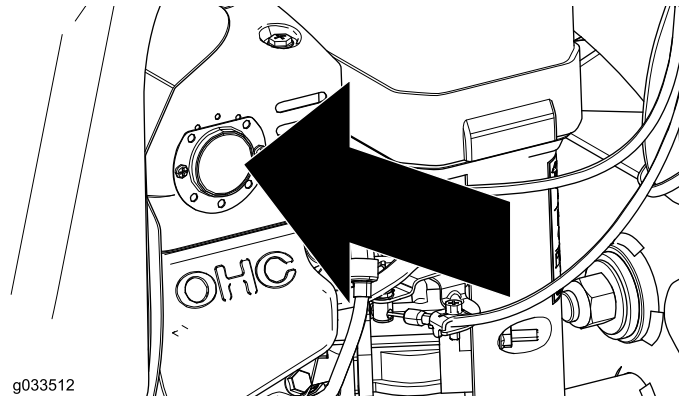

g033512

g033512

Figure 67

4. Install the spark arrester; reverse the steps completed in [Removing the Spark Arrester](#) (page 55)

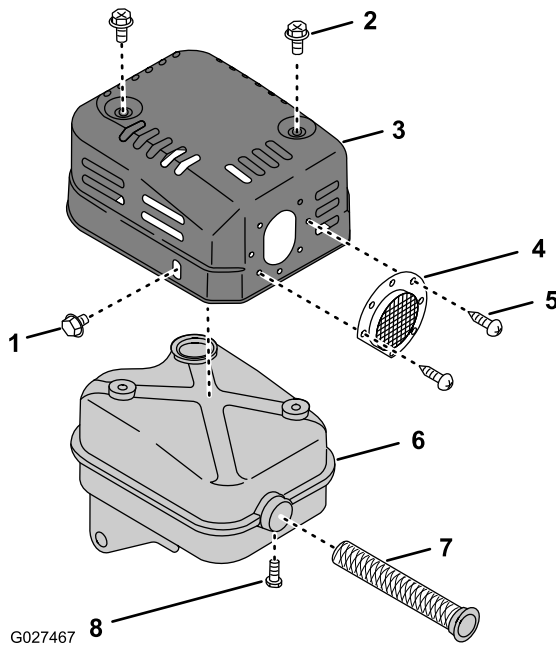

G027467

g027467

**Figure 68**

- |                      |                       |
|----------------------|-----------------------|
| 1. Flanged-head bolt | 5. Self-tapping screw |
| 2. Bolts             | 6. Muffer             |
| 3. Muffler cover     | 7. Spark arrester     |
| 4. Tail screen       | 8. Self-tapping screw |

4. Remove the 2 bolts and 1 flanged-head bolt that secures the muffler cover to the muffer ([Figure 68](#)).
5. Remove the self-tapping screw that secure the spark arrester to the muffer and remove the spark arrester ([Figure 68](#)).

## Cleaning and Assembling the Spark Arrester

1. Remove the spark arrester ([Figure 68](#)).
2. If there are any breaks in the screen or welds are observed, replace the arrester.
3. Clean the arrester with a wire brush and soak in solvent if necessary ([Figure 69](#)).

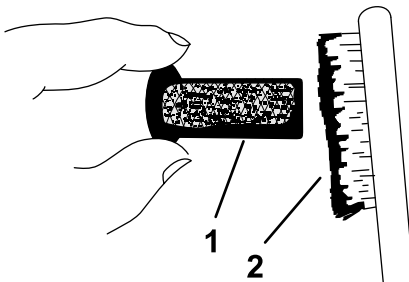

**Figure 69**

g208746



# Fuel System Maintenance

## Cleaning the Fuel Sediment Cup

**Service Interval:** Monthly

1. Prepare the machine for maintenance; refer to [Preparing the Machine \(page 50\)](#).
2. Move the fuel-shutoff valve to the OFF position; refer to [Opening and Closing the Fuel-Shut-Off Valve \(page 21\)](#).
3. Align a drain pan under the body of the fuel-shutoff valve for the carburetor ([Figure 70](#)).

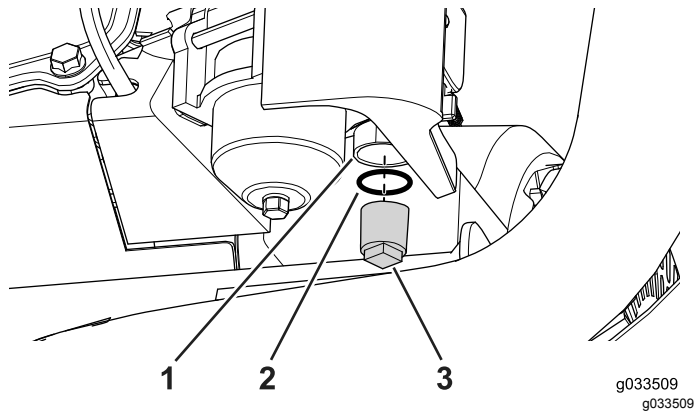

**Figure 70**

- |                      |                 |
|----------------------|-----------------|
| 1. Fuel-shutoff body | 3. Sediment cup |
| 2. Seal              |                 |

4. Rotate the sediment cup counterclockwise and remove the cup from the carburetor ([Figure 70](#)).

**Note:** Check the seal for the sediment cup for damage or wear; replace the seal if it is damaged or worn.

5. Clean the sediment cup in fresh gasoline or kerosene.
6. Hand tighten the sediment cup into the body of the fuel-shutoff valve ([Figure 70](#)).
7. Open the fuel-shutoff valve and check for fuel leaks.

## Servicing the Fuel Strainer

**Service Interval:** Monthly

### Removing the Fuel Tank

1. Move the fuel-shut-off valve to the OFF position; refer to [Opening and Closing the Fuel-Shut-Off Valve \(page 21\)](#).

2. Align a drain pan with a 6.1 L (1.6 US gallons) capacity with a under the carburetor.
3. Rotate the sediment cup counterclockwise and remove the cup from the carburetor.

**Note:** Check the seal for the sediment cup for damage or wear; replace the seal if it is damaged or worn.

4. Move the fuel-shutoff valve to the ON position.

**Note:** Allow the fuel system to drain completely.

5. Remove the 2 bolts 6 x 25 mm and 2 nuts 8 mm that secure the fuel tank to the tank supports ([Figure 71](#)).

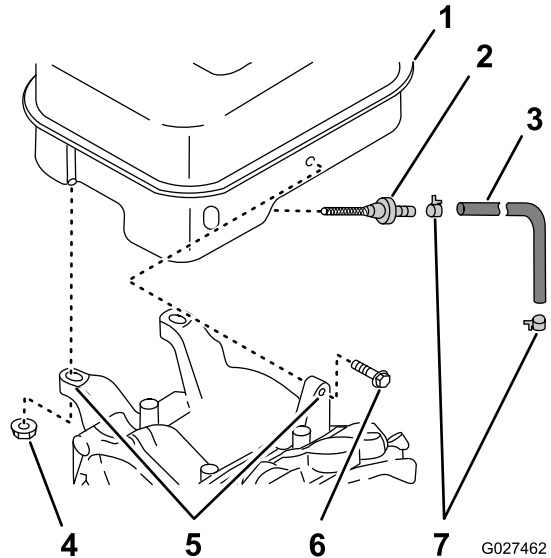

**Figure 71**

- |              |                   |
|--------------|-------------------|
| 1. Fuel tank | 5. Tank supports  |
| 2. Strainer  | 6. Bolt 6 x 25 mm |
| 3. Fuel hose | 7. Clamps         |
| 4. Nuts 8 mm |                   |

6. Loosen the hose clamp and disconnect fuel hose from the fitting on the carburetor ([Figure 72](#)).

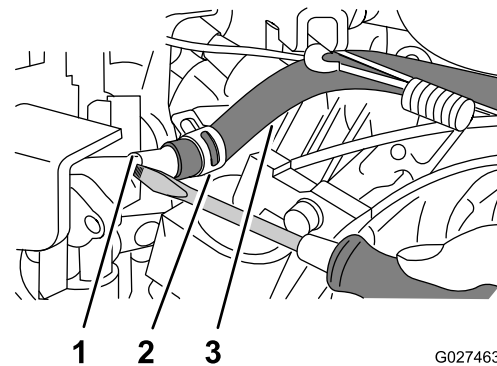

**Figure 72**

- |                         |              |
|-------------------------|--------------|
| 1. Fitting (carburetor) | 3. Fuel hose |
| 2. Clamp                |              |

7. Remove the fuel tank from the crankcase of the engine (Figure 71 and Figure 73).

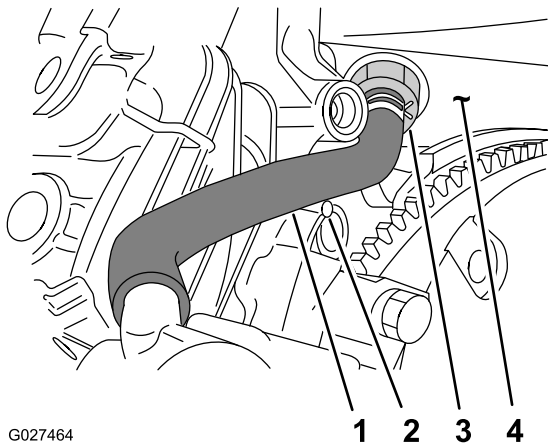

Figure 73

- |              |              |
|--------------|--------------|
| 1. Fuel hose | 3. Strainer  |
| 2. Boss      | 4. Fuel tank |

4. Secure the hose to the carburetor fitting with the clamp (Figure 72).
5. Assemble the tank to the tank supports on the engine with the 2 bolts 6 x 25 mm and 2 nuts 8 mm (Figure 71).
6. Torque the 6 mm bolts to 945 to 1171 N·m (86 to 106 in-lb).
7. Hand tighten the sediment cup into the carburetor.
8. Add fuel to the fuel tank, open the fuel-shutoff valve, and check for fuel leaks.

**Note:** Do not add too much fuel to the tank before you have confirmed that there are no fuel leaks.

## Cleaning the Fuel Strainer

1. Loosen the hose clamp and disconnect the fuel hose from the fitting at the fuel strainer (Figure 71).
2. Rotate the fuel strainer counterclockwise and remove it from the fuel tank (Figure 71).  
**Note:** Check the seal and the fuel strainer for damage or wear. Replace the seal or fuel strainer if the seal or strainer are damaged.
3. Clean the fuel strainer in fresh gasoline or kerosene.
4. Thread the fuel strainer into the fuel tank (Figure 71).
5. Torque the fuel strainer to 3.0 to 4.0 N·m (2.2 to 2.9 ft-lb).
6. Align the fuel hose that you removed in step 1 over the fitting on the fuel strainer (Figure 71 and Figure 73).
7. Secure the hose to the strainer fitting with the clamp (Figure 71 and Figure 73).

## Installing the Fuel Tank

1. Apply medium-grade thread-locking compound to the 8 mm studs in the fuel tank and the 2 bolts 6 x 25 mm.
2. Align the fuel tank to the tank supports on the engine (Figure 71).
3. Align the fuel hose that you removed in step 6 of [Removing the Fuel Tank \(page 57\)](#) to the fitting on the carburetor (Figure 72 and Figure 73).

# Electrical System Maintenance

## Servicing the Battery

Service Interval: Monthly

Always keep the battery clean and fully charged. Use a paper towel to clean the battery case. If the battery terminals are corroded, clean them with a solution of four parts water and one part baking soda. Apply a light coating of grease to the battery terminals to prevent corrosion.

Voltage: 12 V

### ⚠ DANGER

Charging or jump starting the battery may produce explosive gases. Battery gases can explode causing serious injury.

- Keep sparks, flames, or cigarettes away from battery.
- Ventilate when charging or using battery in an enclosed space.
- Ensure that the venting path of battery is always open once the battery is filled with acid.
- Do not lean over the batteries.
- Always shield eyes and face from battery.

### ⚠ DANGER

Battery electrolyte contains sulfuric acid, which is poisonous and can cause severe burns. Swallowing electrolyte can be fatal or if it touches skin can cause severe burns.

- Wear eye protection to shield your eyes and rubber gloves to protect your skin and clothing when handling electrolyte.
- Do not swallow electrolyte.
- In the event of an accident, flush with water and call a doctor immediately.

## Checking the Battery Charge

### ⚠ CAUTION

If the ignition is in the ON position, there is potential for sparks and engagement of components. Sparks could cause an explosion or moving parts could accidentally engage causing personal injury.

**Be sure ignition switch is in the OFF position before charging the battery.**

1. Prepare the machine for maintenance; refer to [Preparing the Machine \(page 50\)](#).
2. Remove the free end of the battery strap from the buckle and remove the battery cover from the battery box ([Figure 74](#)).

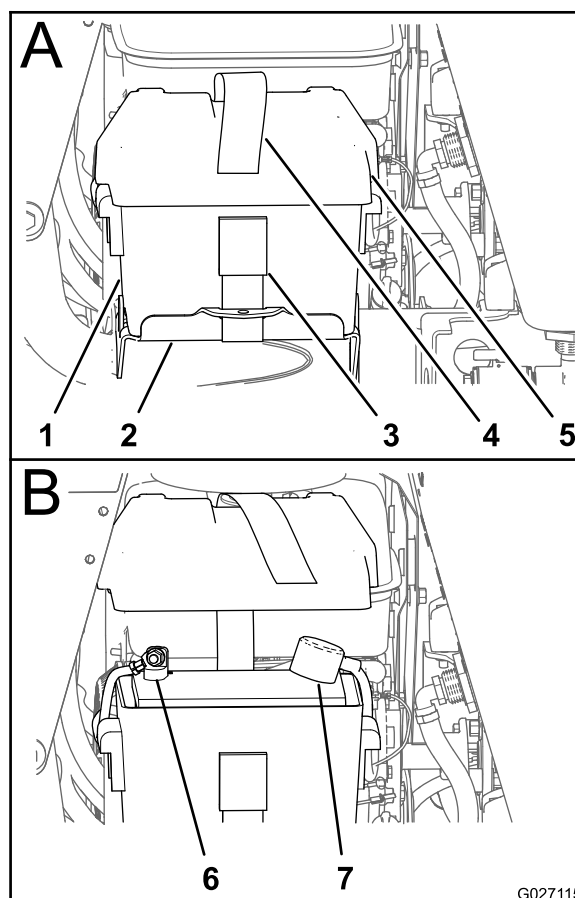

Figure 74

- |                    |                      |
|--------------------|----------------------|
| 1. Battery box     | 5. Battery cover     |
| 2. Battery support | 6. Negative terminal |
| 3. Buckle          | 7. Positive terminal |
| 4. Battery strap   |                      |

3. Measure the voltage of the battery with a voltmeter.
4. Use the table below to locate the charge state or the battery, and if needed, the battery-charger

setting and charging interval recommended to charge the battery to 12.6 V or greater; refer to the battery charge table below.

**Important:** Ensure that the negative battery cable is disconnected, and the battery charger used for charging the battery has an output of 16 V and 7 A or less to avoid damaging the battery (see chart for recommended charger settings).

### Battery Charge Table

Voltage Reading	Percent Charge	Maximum Charger Settings	Charging Interval
12.6 or greater	100%	16 V/ 7 A	No Charging Required
12.4 – 12.6	75–100%	16 V/ 7 A	30 Minutes
12.2 – 12.4	50–75%	16 V/ 7 A	1 Hour
12.0–12.2	25–50%	14.4 V/ 4 A	2 Hours
11.7–12.0	0–25%	14.4 V/ 4 A	3 Hours
11.7 or less	0%	14.4 V/ 2 A	6 Hours or More

- If the positive cable is also disconnected, connect the **positive (red) cable** to the positive-battery terminal and slip terminal cover over the positive terminal (Figure 74).
- Remove the screw, washer, and ground cable from the engine. Secure the battery cable to the battery terminal with the bolt, washer, and nut and torque the nut and bolt to 1978 to 2542 N·cm (175 to 225 in-lb).

**Note:** If time does not permit charging the battery or if charging equipment is not available, connect the negative-battery cables and run the vehicle continuously for 20 to 30 minutes to charge the battery.

- Align the battery cover to the battery box and secure the cover and box to the battery tray with the battery strap (Figure 74).

## Charging the Battery

### ⚠ WARNING

Charging the battery produces gasses that can explode.

Never smoke near the battery and keep sparks and flames away from battery.

**Important:** Always keep the battery fully charged (1.265 specific gravity) to prevent battery damage when the temperature is below 32°F (0°C).

- Remove the battery from the chassis; refer to [Removing the Battery \(page 61\)](#).
- Check the electrolyte level.
- Ensure that the filler caps are installed on the battery.
- Charge the battery for 1 hour at 25 to 30 A or 6 hours at 4 to 6 A.
- When the battery is fully charged, unplug the charger from the electrical outlet, and disconnect the charger leads from the battery posts (Figure 75).
- Install the battery onto the machine and connect the battery cables; refer to [Installing the Battery \(page 61\)](#).

**Note:** Do not run the machine with the battery disconnected; electrical damage may occur.

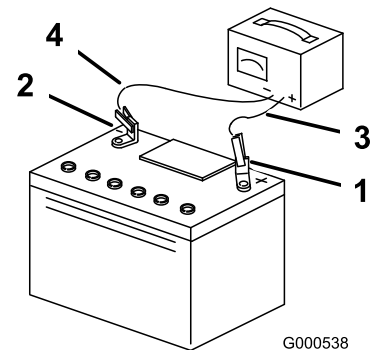

Figure 75

- Positive battery post
- Negative battery post
- Red (+) charger lead
- Black (-) charger lead

# Removing and Installing the Battery

## Removing the Battery

### ⚠ WARNING

Battery terminals or metal tools could short against metal machine components causing sparks. Sparks can cause the battery gasses to explode, resulting in personal injury.

- When removing or installing the battery, do not allow the battery terminals to touch any metal parts of the machine.
- Do not allow metal tools to short between the battery terminals and metal parts of the machine.

### ⚠ WARNING

Incorrect battery-cable routing could damage the machine and cables causing sparks. Sparks can cause the battery gasses to explode, resulting in personal injury.

- Always disconnect the negative-battery cable (black) before disconnecting the positive (red) cable.
  - Always connect the positive-battery cable (red) before connecting the negative (black) cable.
1. Prepare the machine for maintenance; refer to [Preparing the Machine \(page 50\)](#).
  2. Remove the battery cover ([Figure 74](#)); refer to step 2 of [Checking the Battery Charge \(page 59\)](#).
  3. Remove the hex-flanged bolt and flanged nut from the negative-battery cable and negative (-) battery terminal, and remove the cable from the battery ([Figure 76](#)).

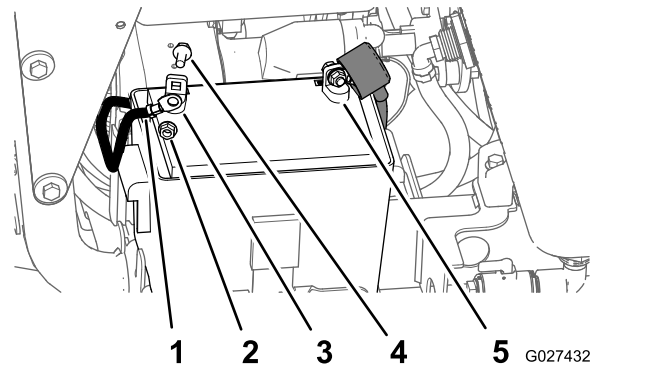

Figure 76

1. Negative-battery-cable cover (black)
2. Flanged nut
3. Negative (-) battery terminal
4. Flanged bolt
5. Positive (+) battery terminal

4. Slide the red-terminal cover off the positive-battery terminal ([Figure 76](#)).
5. Remove the hex-flanged bolt and flanged nut from the positive (red) battery cable and the positive (+) battery terminal, and remove the cable from the battery ([Figure 76](#)).
6. Remove the battery and battery box from the battery tray of the machine.

## Installing the Battery

1. Place the battery into the battery box.
2. Position the battery and battery box onto the battery tray of the machine.
3. Install the positive (red) battery cable to positive (+) battery terminal with a flanged bolt and flanged nut ([Figure 76](#)).
4. Slide the red terminal cover over the positive-battery terminal.
5. Install the negative battery cable to the negative (-) battery terminal with a flanged bolt and flanged nut ([Figure 76](#)).
6. Align the battery cover to the battery box and secure the cover and box to the battery tray with the battery strap ([Figure 74](#))

# Jump-Starting the Machine

## ⚠ DANGER

Jump-starting a battery that is cracked, frozen, has low electrolyte level, or an open/shorted battery cell, can cause an explosion resulting in serious personal injury.

Do not jump-start a battery if these conditions exist; replace the battery.

## ⚠ CAUTION

Corrosion or loose connections can cause unwanted electrical voltage spikes at any time during the jump-starting procedure.

Do not attempt to jump start a machine with loose or corroded battery terminals, or damage to the engine can occur.

## ⚠ CAUTION

Connecting the jumper cables incorrectly (wrong polarity) can immediately damage the electrical system.

Be certain of the battery-terminal polarity and the jumper-cable polarity when connecting to the battery.

**Important:** Be sure that the vehicles do not touch and that both electrical systems are off and at the same rated system voltage. These instructions are for negative-ground systems only.

**Important:** Use the properly sized jumper cables (4 to 6 AWG) with short lengths to reduce the voltage drop between systems. Ensure that the cables are color coded or labeled for the correct polarity.

**Note:** The following instructions are adapted from the SAE J1494 Rev. Dec. 2001 – Battery Booster Cables – Surface Vehicle Recommended Practice (SAE – Society of Automotive Engineers).

1. Check the battery terminals of the discharged battery and the booster battery for corrosion (white, green, or blue “snow”).

**Note:** Clean the corrosion from the battery terminals prior to jump starting. Tighten the battery cable connections as necessary.

2. Ensure that the booster is a 12-volt battery with a sufficient amp rating that is in good condition and fully charged.

**Note:** Ensure that the vent caps are tight and level. If available, place a damp cloth over any vent caps on both batteries.

3. Connect the positive (+) cable clamp (red) to the positive (+) terminal of the discharged battery (Figure 77).

**Note:** The positive-battery cable is wired to the starter or solenoid.

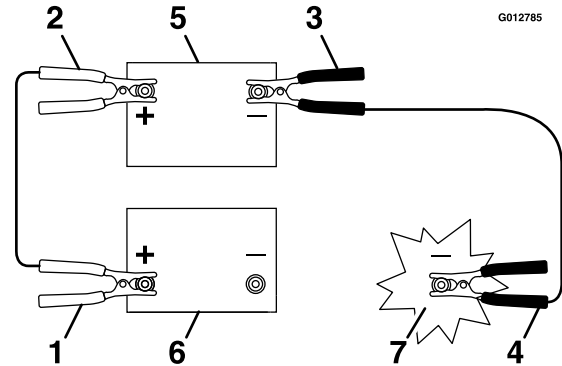

Figure 77

1. Positive (+) cable on the discharged battery
2. Positive (+) cable on booster battery
3. Negative (-) cable on the booster battery
4. Negative (-) cable on the engine block
5. Booster battery
6. Discharged battery
7. Engine block

4. Connect the other positive (+) cable clamp (red) to the positive terminal of the booster battery.
5. Connect the negative (-) cable clamp (black) to the negative terminal of the booster battery.
6. Connect the other negative (-) cable clamp (black) to the engine block of the stalled machine and away from the discharged battery.

**Important:** Do not connect the negative (-) cable clamp (black) to the negative battery post of the discharged battery.

7. Stand away from the discharged battery of the machine.
8. Start the machine and remove the cables in the reverse order of connection, disconnect the engine block connection first.

## Servicing the Fuses

The electrical system is protected by fuses, and requires no maintenance. If a fuse blows, check the component or circuit for a malfunction or short.

1. Remove the negative-battery cable from the battery terminal; refer to steps 2 and 3 of [Removing the Battery](#) (page 61).

**Note:** Ensure that the negative battery cable does not touch the battery terminal.

2. Push the tab on the fuse/relay holder and separate the cover from the holder (Figure 78).
3. Pull the fuse from the socket of the fuse/relay holder (Figure 78).

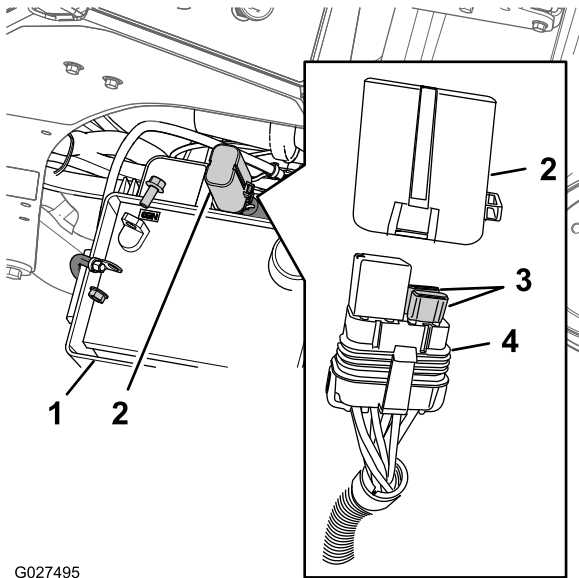

**Figure 78**

- |                |                      |
|----------------|----------------------|
| 1. Battery box | 3. Fuses             |
| 2. Cover       | 4. Fuse/relay holder |

4. Install a fuse of the same type (20 A) into the socket of the fuse/relay holder (Figure 78).
5. Install the cover on to the fuse/relay holder until it locks into place (Figure 78).
6. Install the negative-battery cable from the battery terminal; refer to steps 5 and 6 of [Installing the Battery](#) (page 61).

## Drive System Maintenance

### Checking the Air Pressure in the Tires

**Service Interval:** Every 50 hours

**Note:** Service the air pressure in both the front and rear tires.

1. Prepare the machine for maintenance; refer to [Preparing the Machine](#) (page 50).
2. Check tire pressure in front and rear tires.
3. If necessary, adjust the air pressure in the tires to 83 to 97 kPa (12 to 14 psi).

### Torquing the Axle Bolts

**Service Interval:** Yearly

1. Torque the 4 axle bolts on both front and rear wheels (Figure 79) to 48 N·m (35 ft-lb).
2. Torque the 2 setscrews on each rear wheel to 12 N·m (105 in-lb).

**Important:** If you remove the wheel(s) for maintenance, apply medium-grade thread-locking compound to the threads of the bolts before installing the wheel(s)

**Important:** If you remove the rear wheel(s) for maintenance apply a copper-based, anti-seizing compound on the rear-axle shafts.

**Important:** Do not use anti-seize compound on the wheel bolts.

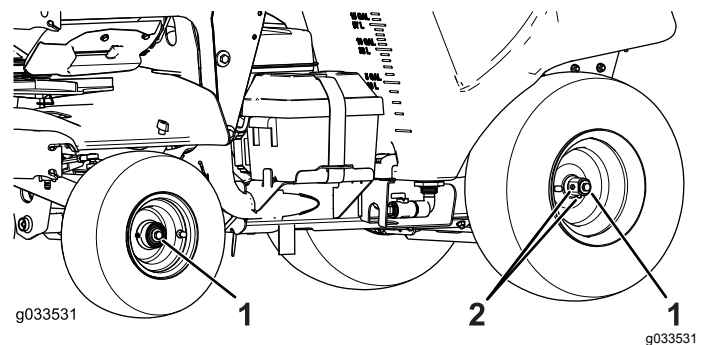

**Figure 79**

- |               |              |
|---------------|--------------|
| 1. Axle bolts | 2. Setscrews |
|---------------|--------------|

# Aligning the Front Wheels

**Operator supplied equipment:** 2 bolts 9 x 76 mm (5/16 x 3 inch) or longer

1. Prepare the machine for maintenance; refer to [Preparing the Machine \(page 50\)](#).
2. Check the tire pressure; refer to [Checking the Air Pressure in the Tires \(page 63\)](#).
3. Center and secure the steering control by aligning 2 bolts (5/16 x 3 inch) through the outside holes on the steering control and through the control column.

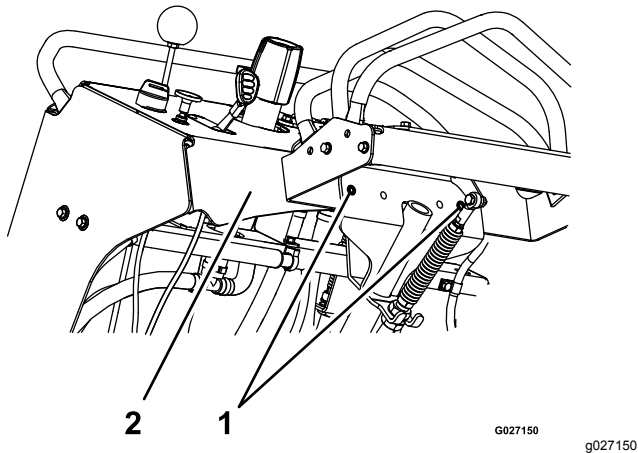

**Figure 80**

1. Outside holes (steering control)
2. Control column

4. Measure the distance between the 2 front faces of the front tires as shown in [Figure 81](#).

Record the front measurement here

\_\_\_\_\_

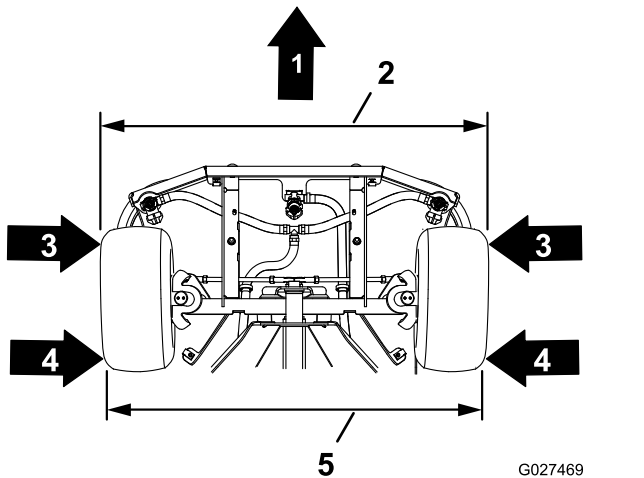

**Figure 81**

Viewed underneath machine

1. Front of the machine
2. Front measurement
3. Front face of the tire
4. Rear face of the tire
5. Rear measurement

5. Measure the distance between the 2 rear faces of the front tires as shown in [Figure 81](#).

Record the front measurement here

\_\_\_\_\_

**Note:** The front measurement should be 6.4 to 12.7 mm (1/4 to 1/2 inch) larger than the rear measurement.

6. If the front measurement is smaller than 6.4 mm (1/4 inch) or larger than 12.7 mm (1/2 inch), adjustment the rod ends for the steering linkage as follows:

- A. Remove the 4 thumb screws that secure the front cover (below the impeller) to the chassis and remove the cover ([Figure 82](#)).

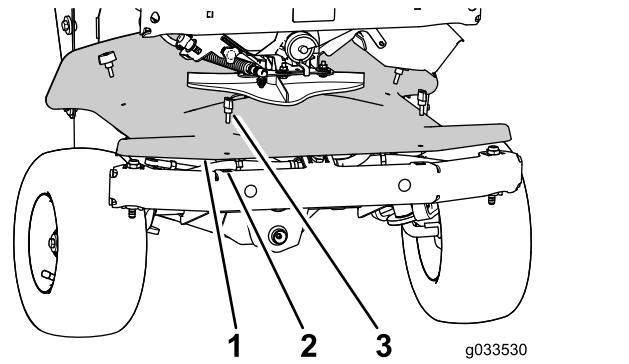

**Figure 82**

1. Forward cover
2. Clip nut
3. Thumb screw

- B. Loosen the jam nuts at the rod ends.

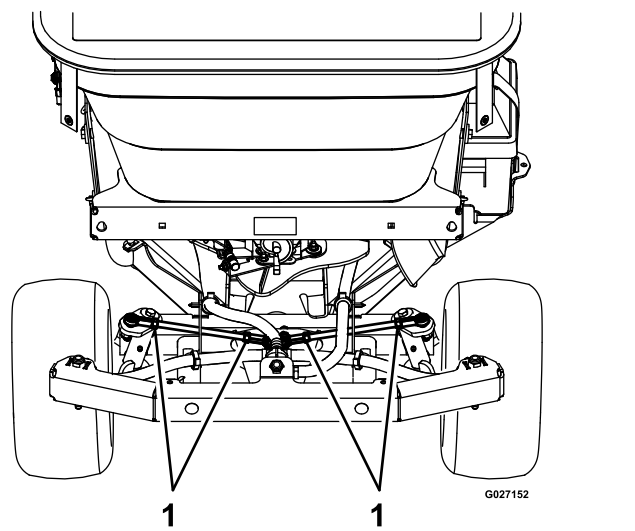

**Figure 83**

1. Jam nuts

- C. Rotate the steering rod to lengthen or shorten the linkage. Adjust both the left and right steering linkages equally.



**Note:** The factory center-to-center distance between the ball-joint rod ends at the steering linkage is 23.3 cm (9.21 inches).

- D. Tighten the jam nuts.
  - E. Align the holes in the front cover with the clip nuts in the chassis and secure the cover with the 4 thumb nuts that you removed in [A](#).
7. Remove the bolts that you installed in step 3 from the control column and steering control.

6. If the fluid level is too low, add the specified fluid into the expansion tank.
7. Install the tank cap onto the expansion tank and tighten the cap until it is snug ([Figure 84](#)).

**Note:** Do not overtighten the cap.

## Servicing the Transaxle

**Service Interval:** Every 50 hours

**Transaxle Oil Type:** Toro® HYPR-OIL™ 500 hydraulic oil or Mobil® 1 15W-50

1. Prepare the machine for maintenance; refer to [Preparing the Machine \(page 50\)](#).
2. Rotate counterclockwise the 2 quarter-turn fasteners that secure the knee pad to the chassis of the machine ([Figure 84](#)).

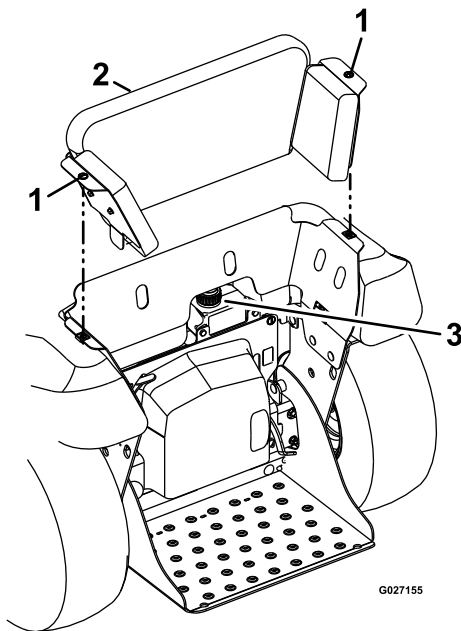

**Figure 84**

g027155

- |                         |                       |
|-------------------------|-----------------------|
| 1. Quick release screws | 3. Oil expansion tank |
| 2. Knee pad             |                       |

- 
3. Lift the knee pad up and rearward slightly and remove the pad from the machine ([Figure 84](#)).
  4. Clean area around fluid-expansion tank and remove cap ([Figure 84](#)).
  5. Check the fluid level in the expansion tank.

**Note:** The fluid-level cover the bottom port in tank

# Controls System Maintenance

## Adjusting the Pattern Control Cable for the Spreader

1. Prepare the machine for maintenance; refer to [Preparing the Machine \(page 50\)](#).
2. Empty the hopper; refer to [Emptying the Spreader \(page 26\)](#)
3. Close the impeller gate by pushing the wide-distribution impeller-gate lever forward fully ([Figure 85](#)).

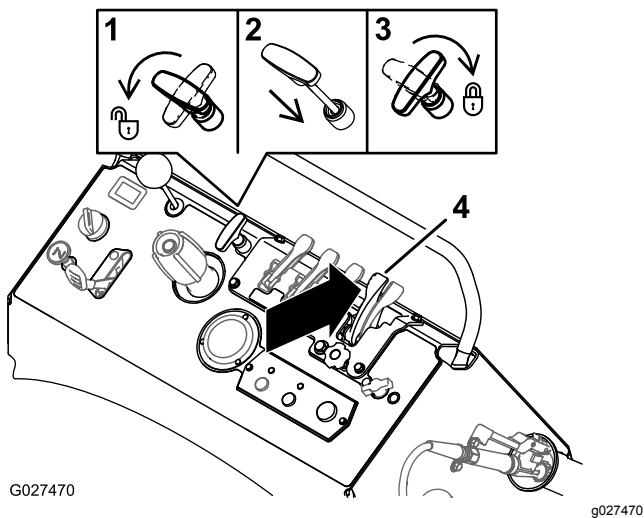

**Figure 85**

- |   |  |
|---|--|
| 1. Unlock—spread pattern control handle (rotate counterclockwise) | 3. Lock—spread pattern control handle (rotate clockwise) |
| 2. Push down—spread pattern control handle                        | 4. Push forward—wide-distribution impeller-gate lever    |

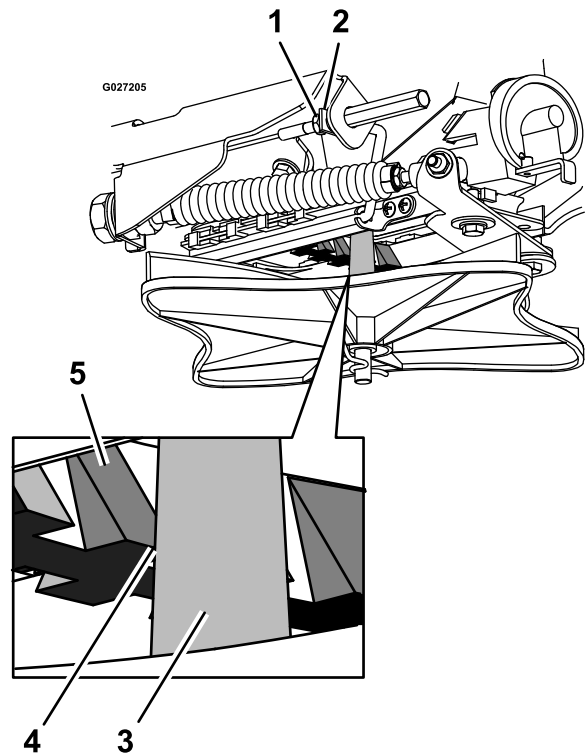

**Figure 86**

1. Jam nut (pattern control cable)
2. Linkage rod
3. Impeller shaft
4. 1/8 inch (3.2 mm) gap between ramp tooth and impeller shaft
5. Ramp tooth

6. Pull the linkage rod until there is 1/8 inch (3.2 mm) gap between the ramp tooth and the impeller shaft ([Figure 86](#)).
7. Tighten the jam nut ([Figure 86](#)).
8. Adjust the spread-pattern-control handle; refer to [Adjusting the Spreader Pattern \(page 30\)](#).

4. Rotate the spread-pattern-control handle counterclockwise, push the handle down, and rotate the spread-pattern-control handle clockwise(3) refer to [Figure 85](#).
5. Loosen the jam nut at the end of the pattern-control cable ([Figure 86](#)).

# ***Maintaining the Chassis***

## **Checking the Machine for Loose Hardware**

**Service Interval:** Before each use or daily

1. Prepare the machine for maintenance; refer to [Preparing the Machine \(page 50\)](#).
2. Visually inspect machine for damaged or worn parts, and check for loose hardware.

**Note:** Before operating the machine, replace any damaged parts and tighten all loose hardware.

# ***Maintaining the Sprayer System***

## **Checking Sprayer System**

**Service Interval:** Every 50 hours

1. Prepare the machine for maintenance; refer to [Preparing the Machine \(page 50\)](#).
2. Check all hoses, nozzles, and fittings for damage and leaks.  
**Note:** Replace all damaged or leaking sprayer components.
3. Check the nozzle strainers and in-line strainers for accumulation of dirt and chemical sludge.

**Note:** Clean or replace strainers with an accumulation of dirt and chemical sludge.

# Cleaning

## Cleaning the Engine and the Exhaust System Area

**Service Interval:** After each use (may be required more often in dry or dirty conditions.)

### **⚠ CAUTION**

Excessive debris around engine-air intake and exhaust system area can cause engine, exhaust area, and hydraulic system to overheat which can create a fire hazard.

Clean all debris from engine and exhaust system area.

1. Prepare the machine for maintenance; refer to [Preparing the Machine \(page 50\)](#).
2. Clean all debris from screen next to the starter grip of the engine, around engine shrouding, fuel tank, and exhaust system area.
3. Wipe up any excessive grease or oil around the engine and exhaust system area.
4. Clean muffler-heat shields of all debris, dirt, and oil.

## Cleaning the Debris from the Machine

**Service Interval:** After each use

1. Prepare the machine for maintenance; refer to [Preparing the Machine \(page 50\)](#).
2. Clean off any debris or chemical build-up on the machine, especially the nozzles, sprayer-tank opening, impeller, and the spray wand and its holder

## Removing the Engine Shroud and Cleaning the Cooling Fins

**Service Interval:** Every 80 hours

1. Prepare the machine for maintenance; refer to [Preparing the Machine \(page 50\)](#).
2. Remove cooling shroud from engine.
3. Clean cooling fins of the engine.

**Note:** Also, clean dust, dirt, and oil from external surfaces of engine which can cause improper cooling.

4. Install the cooling shrouds onto the engine.

**Note:** Operating the engine without cooling shrouds will cause engine damage due to overheating.

## Waste Disposal

### Chemical Disposal

Improper chemical disposal can pollute the environment and cause health issues.

Follow the disposal directions on the chemical-manufacturer's label. Dispose of chemicals and containers in accordance to local/state/federal laws.

### Disposing of the Engine Oil

Engine oil and hydraulic fluid are both pollutants to the environment. Dispose of used pollutants at a certified-recycling center or according to your state and local regulations.

## Disposing of the Battery

### **⚠ DANGER**

Battery electrolyte contains sulfuric acid, which is poisonous and can cause severe burns. Swallowing electrolyte can be fatal or if it touches skin can cause severe burns.

- Wear eye protection to shield eyes, and rubber gloves to protect skin and clothing when handling electrolyte.
- Do not swallow electrolyte.
- In the event of an accident, flush with water and call a doctor immediately.

Federal law states that batteries should not be placed in the garbage. Management and disposal practices for batteries must follow relevant federal, state, or local laws.

Take the battery to a local certified-recycling center if you replace a worn or damaged battery or if the machine no longer operates and is being scrapped.

**Note:** If no local recycling is available, return the battery to any certified battery seller.

## Storage

1. Set sprayer-pump switch to the OFF position, stop the machine, move motion-control lever to the NEUTRAL position, shut off the engine, wait for all moving parts to stop, remove key, and engage parking brake.
2. Remove dirt and grime from the entire machine.  
**Important:** You can wash the machine with mild detergent and water. Do not pressure wash the machine. Avoid excessive use of water, especially near the engine and hydrostatic drive.
3. Service the air cleaner; refer to [Servicing the Air Cleaner \(page 51\)](#).
4. Lubricate the machine; refer to [Lubricating the Grease Fittings \(page 51\)](#).
5. Change the engine oil; refer to [Changing the Engine Oil \(page 53\)](#).
6. Remove the rear wheels, apply a copper-based, anti-seizing compound to the rear-axle shafts, and install the wheels; refer to [Torquing the Axle Bolts \(page 63\)](#).
7. Check and tighten all bolts, nuts, and screws. Repair or replace any part that is damaged.
8. Paint all scratched or bare metal surfaces. Paint is available from your Authorized Service Dealer.
9. Store the machine in a clean, dry garage or storage area.
10. Cover the machine to protect it and keep it clean.

## Preparing the Machine for Extended or Winter Storage

To help protect the pumps from freezing temperatures, ensure that the unit is free of all caustic chemicals and residue.

### Cleaning the Spreader

Perform all the steps in [Cleaning and Lubricating the Spreader \(page 43\)](#).

### Winterizing the Sprayer

#### Emptying the Tank

1. Perform all the steps in [Cleaning the Sprayer System and Wand \(page 44\)](#), [Cleaning the Strainer \(page 45\)](#), and [Cleaning the Sprayer Nozzle \(page 45\)](#).
2. Empty the sprayer system by performing the following:

- A. Empty the sprayer tank; refer to [Emptying the Sprayer Tank \(page 39\)](#).
  - B. Start the machine and set sprayer-pump switch to the ON position
  - C. Push forward the tank agitation lever.
  - D. Pull back the narrow-spray pattern lever.  
**Note:** Run the sprayer nozzle until the narrow nozzle is spraying air.
  - E. Push forward the narrow-spray pattern lever and pull back the wide-spray pattern lever.  
**Note:** Run the sprayer nozzles until the both wide nozzles are spraying air.
  - F. Push forward the wide-spray pattern lever.
3. Shut off the sprayer pump and the engine.

## Preparing the Sprayer System

**Antifreeze type:** 2.5 L (0.7 US gallon) rust inhibiting, non-alcohol based, RV-antifreeze concentrate

**Important:** Do not allow all of the antifreeze mixture to empty from the sprayer tank while running the sprayer nozzles and wand. Keeping some of the antifreeze in the pump, valves, and hoses will help prevent corrosion and damage caused by moist air trapped in the sprayer system.

1. Mix 2.5 L (0.7 US gallon) RV anti-freeze concentrate with 5.1 L (1.3 US gallon) water and pour the antifreeze mixture into the into the sprayer tank.  
**Note:** Use a rust inhibiting, non-alcohol based, RV antifreeze concentrate.
2. Start the machine and set the sprayer-pump switch to the ON position.
3. Pull back the narrow-spray pattern lever to the ON position.  
**Note:** Allow the antifreeze to circulate through sprayer and nozzle.
4. Push forward the narrow-spray pattern lever and pull back the wide-spray pattern lever.  
**Note:** Allow the antifreeze to circulate through sprayer and nozzle.
5. Push forward the wide-spray pattern lever.
6. Remove the wand from its holder, point it in a safe direction, and squeeze the spray-wand trigger.  
**Note:** Allow the antifreeze to circulate through sprayer and nozzle and then return the wand to its holder.
7. Set the sprayer-pump switch to the OFF position and shut off the engine.

# Troubleshooting

**Important:** Ensure that the operator safety mechanisms for the machine are connected and in proper operating condition before you use the machine.

When a problem occurs, do not overlook the simple causes. For example: starting problems could be caused by an empty fuel tank.

The following table lists some of the common causes of trouble. Do not attempt to service or replace major engine items or any items that call for special timing of adjustments procedures (such as valves, governor, etc.). Have this work done by your engine service dealer.

**Note:** When disconnecting electrical connectors, do not pull on the wires to separate the connectors.

Problem	Possible Cause	Corrective Action
The starter does not rotate the engine.	<ol style="list-style-type: none"> <li>1. The parking brake is not engaged.</li> <li>2. The battery does not have a full charge.</li> <li>3. An electrical connection(s) is corroded, loose or faulty.</li> <li>4. A fuse is blown.</li> <li>5. A relay or switch is worn or damaged.</li> </ol>	<ol style="list-style-type: none"> <li>1. Engage the parking brake.</li> <li>2. Charge the battery; refer to the Charging the Battery, and Jump Starting the Machine procedures in the Maintenance section.</li> <li>3. Check the electrical connection(s) for good contact. Clean the connector terminals thoroughly with electrical-contact cleaner, apply dielectric grease to the terminals, and connect the connectors.</li> <li>4. Replace the blown fuse.</li> <li>5. Contact an Authorized Service Dealer.</li> </ol>
The engine does not start, it starts hard, or it fails to keep running.	<ol style="list-style-type: none"> <li>1. The fuel tank is empty.</li> <li>2. The fuel-shutoff valve is closed.</li> <li>3. The throttle lever or choke lever or both are not in the correct position.</li> <li>4. There is dirt in fuel strainer.</li> <li>5. There is dirt, water, or stale fuel is in the fuel system.</li> <li>6. The air-filter elements are dirty.</li> <li>7. An electrical connection(s) is corroded, loose or faulty.</li> <li>8. A relay or switch is worn or damaged.</li> <li>9. The spark plug is faulty.</li> <li>10. The spark-plug wire is not connected to the spark plug.</li> </ol>	<ol style="list-style-type: none"> <li>1. Fill the fuel tank with fuel.</li> <li>2. Open the fuel-shutoff valve.</li> <li>3. Move the throttle control is midway between the SLOW and FAST positions. Set the choke to the ON position when starting a cold engine or set the choke to the OFF position when starting a warm engine.</li> <li>4. Clean or replace the fuel strainer (bottom of fuel tank).</li> <li>5. Contact an Authorized Service Dealer.</li> <li>6. Clean the foam-filter element or replace the paper-filter element.</li> <li>7. Check the electrical connection(s) for good contact. Clean the connector terminals thoroughly with electrical-contact cleaner, apply dielectric grease to the terminals, and connect the connectors.</li> <li>8. Contact an Authorized Service Dealer.</li> <li>9. Clean, adjust or replace spark plug.</li> <li>10. Check the spark-plug wire connection at the spark plug.</li> </ol>

Problem	Possible Cause	Corrective Action
The engine loses power.	<ol style="list-style-type: none"> <li>1. The engine load is excessive.</li> <li>2. The air-filter elements are dirty.</li> <li>3. The oil level in the engine is low.</li> <li>4. The cooling fins and the air passages for the engine are plugged with dirt or debris.</li> <li>5. The vent hole in the fuel cap is plugged.</li> <li>6. There is dirt in the fuel strainer.</li> <li>7. There is dirt, water, or stale fuel in the fuel system.</li> </ol>	<ol style="list-style-type: none"> <li>1. Reduce the ground speed of the machine.</li> <li>2. Clean the foam-filter element or replace the paper-filter element.</li> <li>3. Add oil into the engine to the proper oil level.</li> <li>4. Clean the cooling fins and the air passages.</li> <li>5. Clean the vent hole or replace the fuel cap.</li> <li>6. Clean or replace the fuel strainer (bottom of fuel tank).</li> <li>7. Contact an Authorized Service Dealer.</li> </ol>
The engine overheats.	<ol style="list-style-type: none"> <li>1. The engine load is excessive.</li> <li>2. The oil level in the engine is low.</li> <li>3. The cooling fins and air passages for the engine are plugged with dirt or debris.</li> </ol>	<ol style="list-style-type: none"> <li>1. Reduce the ground speed of the machine.</li> <li>2. Add oil into the engine to the proper oil level.</li> <li>3. Clean the cooling fins and the air passages.</li> </ol>
The machine pulls to the left or the right (with steering control fully forward).	<ol style="list-style-type: none"> <li>1. The air pressure in the tires is not correct.</li> <li>2. The steering linkage is damaged.</li> <li>3. The front wheel toe-out is not correct.</li> <li>4. The front wheel axles are bent or damaged.</li> <li>5. The steering control is bent or damaged.</li> </ol>	<ol style="list-style-type: none"> <li>1. Adjust air pressure in the drive tires.</li> <li>2. Replace steering linkage.</li> <li>3. Align the front wheels; refer to Aligning the Front Wheels procedure.</li> <li>4. Repair or replace the front wheel axles.</li> <li>5. Repair or replace the steering control.</li> </ol>
The machine does not drive.	<ol style="list-style-type: none"> <li>1. The bypass valve is not closed tight.</li> </ol>	<ol style="list-style-type: none"> <li>1. Close the bypass valve.</li> </ol>
The machine vibrates abnormally.	<ol style="list-style-type: none"> <li>1. The engine-mounting bolts are loose.</li> <li>2. The coupling bolts and nuts for the drive shaft are loose.</li> </ol>	<ol style="list-style-type: none"> <li>1. Tighten the engine-mounting bolts.</li> <li>2. Tighten the appropriate fasteners.</li> </ol>
The impeller does not rotate.	<ol style="list-style-type: none"> <li>1. There is debris buildup at the impeller.</li> <li>2. The hopper screen is plugged.</li> <li>3. The impeller motor is loose or damaged.</li> <li>4. An electrical component for the impeller motor system is open.</li> <li>5. The impeller On/Off switch is in the OFF position or the impeller speed control is set too slow.</li> <li>6. The impeller-drive pin is missing.</li> <li>7. The bearings failed in the impeller motor.</li> </ol>	<ol style="list-style-type: none"> <li>1. Clean the impeller.</li> <li>2. Clean the hopper screen.</li> <li>3. Repair or replace the impeller motor.</li> <li>4. Check the electrical connections.</li> <li>5. Set the impeller On/Off switch to the ON position and check the position of the knob for the impeller-speed control.</li> <li>6. Replace the drive pin.</li> <li>7. Replace the bearings in the motor or the motor assembly.</li> </ol>



Problem	Possible Cause	Corrective Action
The spreader or sprayer pattern is uneven.	<ol style="list-style-type: none"> <li>1. The impeller is dirty or damaged.</li> <li>2. The spreader-pattern control is not adjusted properly.</li> <li>3. The sprayer nozzles are clogged.</li> <li>4. The hopper screen is plugged.</li> <li>5. Material in the hopper is clumped over the gate.</li> <li>6. The diffuser ramp setting is incorrect.</li> </ol>	<ol style="list-style-type: none"> <li>1. Clean, repair, or replace the impeller.</li> <li>2. Adjust the spreader-pattern control; refer to the Adjust the Spreader Pattern procedure in the Using the Spreader section.</li> <li>3. Clean or replace the nozzles.</li> <li>4. Clean the hopper screen.</li> <li>5. Check to see if the agitator pin for the shaft of the impeller motor is present.</li> <li>6. Adjust the position of the control cable.</li> </ol>
There is no spray from the sprayer nozzles in the boom or the nozzles have poor output.	<ol style="list-style-type: none"> <li>1. The sprayer tank is empty.</li> <li>2. The sprayer-pump supply valve is closed or partially closed.</li> <li>3. The strainer is clogged or damaged.</li> <li>4. The pump is clogged or damaged.</li> <li>5. The nozzles are clogged.</li> <li>6. The hoses are clogged, kinked, or damaged.</li> <li>7. The tank-agitation lever is in the ON position.</li> <li>8. The sprayer-pattern lever is not in the ON position.</li> <li>9. The sprayer pressure and ground speed are incorrect.</li> <li>10. The chemical mixture in the sprayer tank is incorrect.</li> <li>11. The spray system is leaking.</li> </ol>	<ol style="list-style-type: none"> <li>1. Fill the sprayer tank.</li> <li>2. Fully open the sprayer-pump supply valve.</li> <li>3. Clean, repair, or replace the strainer.</li> <li>4. Clean, repair, or replace the pump.</li> <li>5. Clean or replace the nozzles.</li> <li>6. Clean, repair, or replace the hoses.</li> <li>7. Move the tank-agitation lever to the OFF position.</li> <li>8. Move the narrow- or wide-sprayer pattern lever to the ON position.</li> <li>9. Adjust the sprayer pressure and the ground speed of the machine.</li> <li>10. Follow chemical manufacturer's recommendation.</li> <li>11. Inspect the components of the sprayer system; clean, repair, or replace the sprayer- system components as needed.</li> </ol>
No material dispensed from hopper.	<ol style="list-style-type: none"> <li>1. Hopper screen is plugged.</li> <li>2. Gate not adjusted properly.</li> </ol>	<ol style="list-style-type: none"> <li>1. Clean hopper screen.</li> <li>2. Adjust the gate. See <b>Spreader Pattern Adjustment</b> section in Operation.</li> </ol>
The spray wand does not work.	<ol style="list-style-type: none"> <li>1. The sprayer tank is empty.</li> <li>2. The sprayer-wand-pressure control is in the wrong position.</li> <li>3. The wand is clogged or damaged.</li> <li>4. The spray nozzle for the wand is clogged.</li> <li>5. The trigger is not pressed.</li> <li>6. The hose is clogged or damaged.</li> <li>7. The hose is not connected to the wand.</li> <li>8. The hose for the wand is kinked.</li> </ol>	<ol style="list-style-type: none"> <li>1. Fill the sprayer tank.</li> <li>2. Rotate the pressure control to the OPEN position.</li> <li>3. Clean, repair, or replace the wand.</li> <li>4. Clean or replace the nozzle.</li> <li>5. Press the trigger.</li> <li>6. Clean, repair, or replace the hoses.</li> <li>7. Connect the hose to the wand.</li> <li>8. Straighten the kink in the hose.</li> </ol>

Problem	Possible Cause	Corrective Action
<p>The indicator light above the impeller On/Off switch is illuminated or flashing.</p>	<ol style="list-style-type: none"> <li>1. The indicator light is flashing at a slow, constant rate and the —impeller motor speed is not adjustable (locked).</li> <li>2. The indicator light flashes for 2 seconds and then pulses 2 times—The electrical system for the impeller motor is over current.</li> <li>3. The indicator light flashes fast and constant and then pulses 4 times—the electrical system for the machine is under voltage.</li> <li>4. The indicator light flashes fast and then pulses 5 times—the electrical system for the machine is over voltage.</li> </ol>	<ol style="list-style-type: none"> <li>1. While the impeller motor is running, press and hold the impeller On/Off switch for 5-seconds to reset impeller motor speed control; or shut off the engine, and then start the engine; and/or Contact an Authorized Service Dealer.</li> <li>2. Check the electrical connections for damage and corrosion; inspect the impeller for blockage; and/or contact an Authorized Service Dealer.</li> <li>3. Run the engine at high idle with all spreader function turned off to charge the battery until the flashing indicator light resets; check the condition of the battery; check the electrical harness for loose or damaged connections; check the charging system of the engine for electrical output; and/or contact an Authorized Service Dealer.</li> <li>4. check charging system of the engine for electrical output and/or contact an Authorized Service Dealer.</li> </ol>
<p>The indicator light above the sprayer switch is illuminated or flashing.</p>	<ol style="list-style-type: none"> <li>1. The indicator light flashes for 2 seconds and then pulses 2 times—The electrical system for the sprayer pump is over current.</li> <li>2. The indicator light flashes fast and constant and then pulses 4 times—the electrical system for the machine is under voltage.</li> <li>3. The indicator light flashes fast and then pulses 5 times—the electrical system for the machine is over voltage.</li> </ol>	<ol style="list-style-type: none"> <li>1. Check the electrical connections for damage and corrosion; inspect the sprayer pump for blockage and drainage; and/or contact an Authorized Service Dealer.</li> <li>2. Run engine at high idle with the sprayer function turned off to charge the battery until the flashing indicator light resets; check the condition of the battery; check the electrical harness for loose or damaged connections; check the charging system of the engine for electrical output; and/or contact an Authorized Service Dealer.</li> <li>3. check the charging system of the engine for electrical output and/or contact an Authorized Service Dealer.</li> </ol>

# Schematics

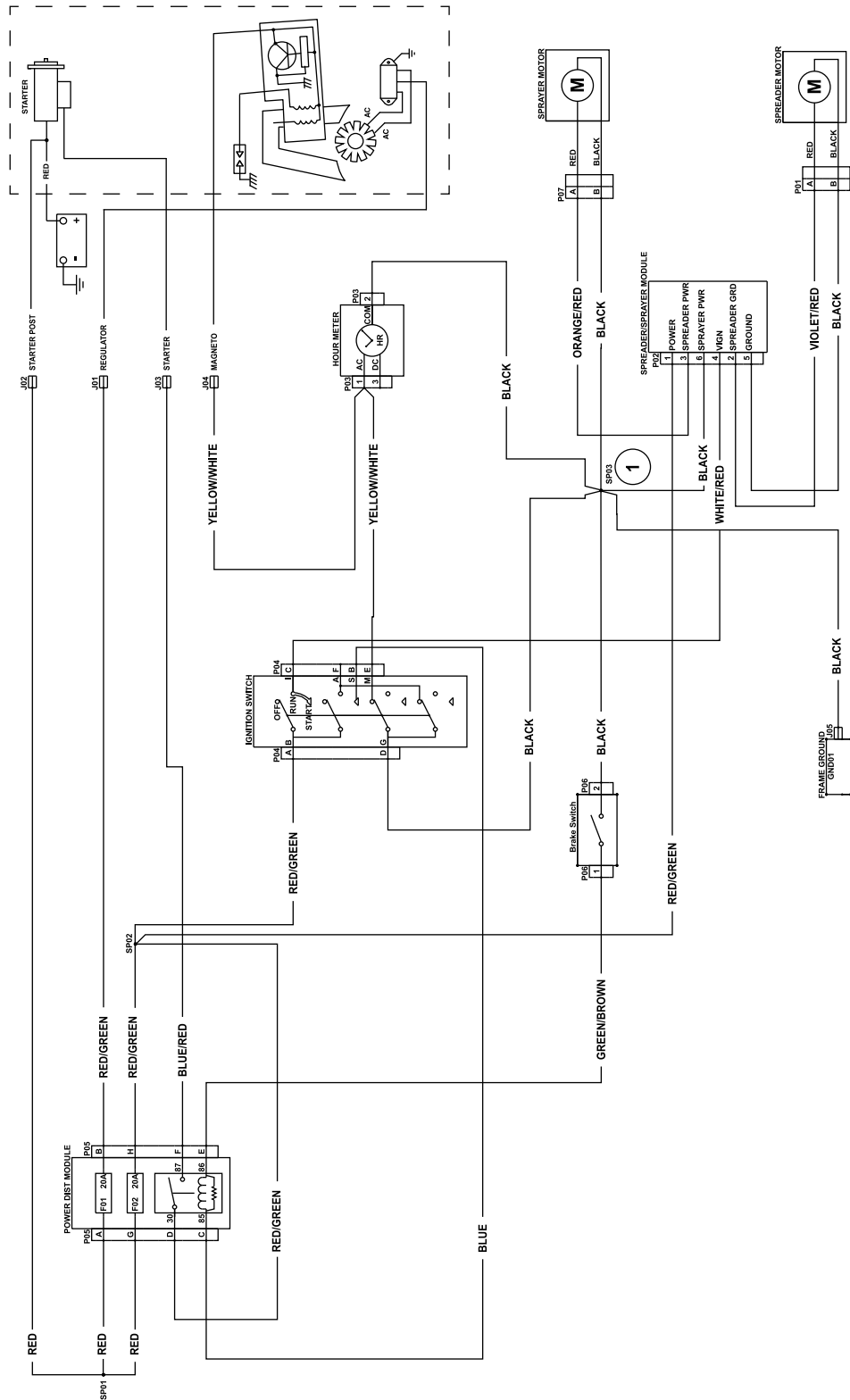

G027149

Electrical Schematic (Rev. A)

g027149

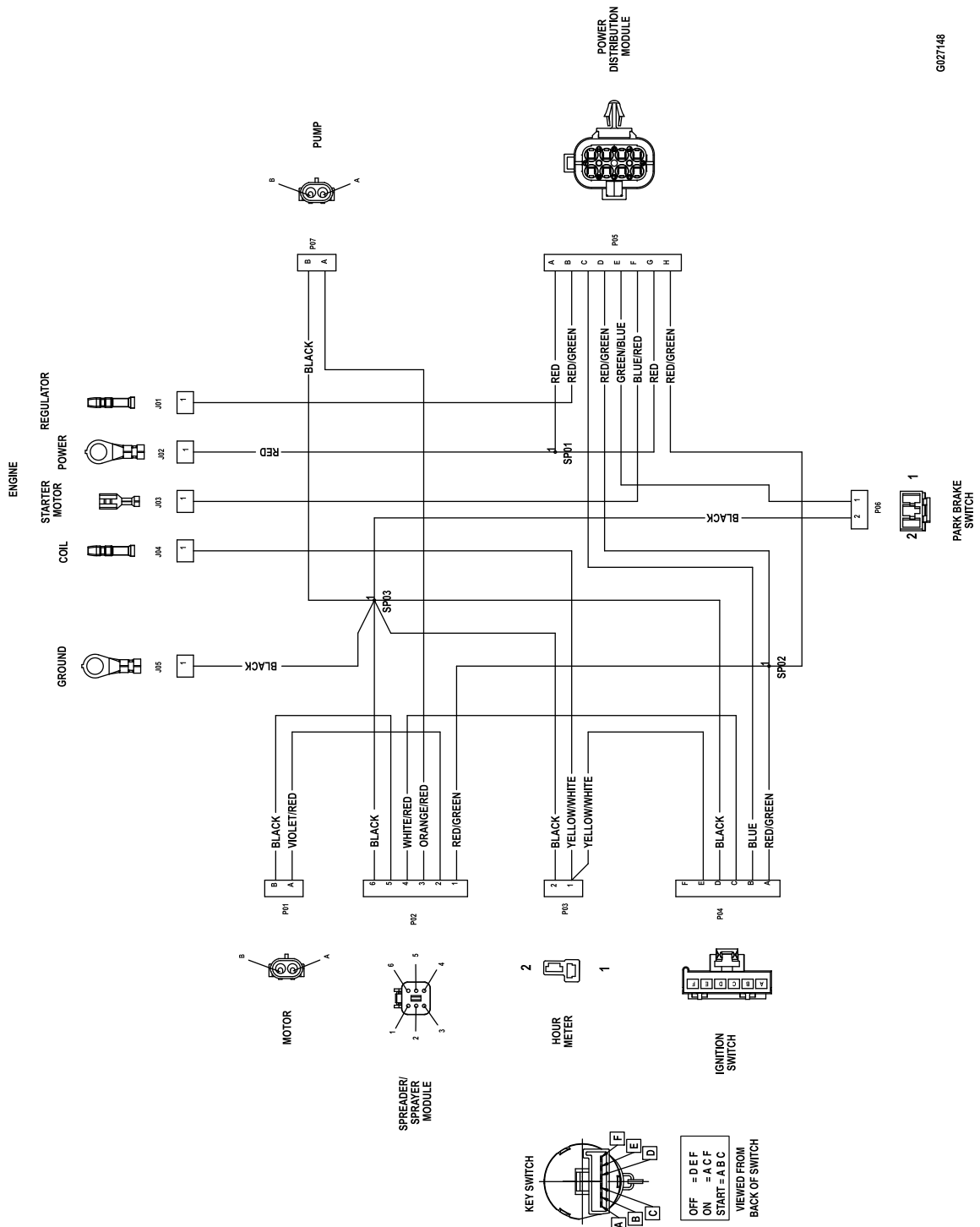

G027148

Electrical Diagram (Rev. A)

g027148

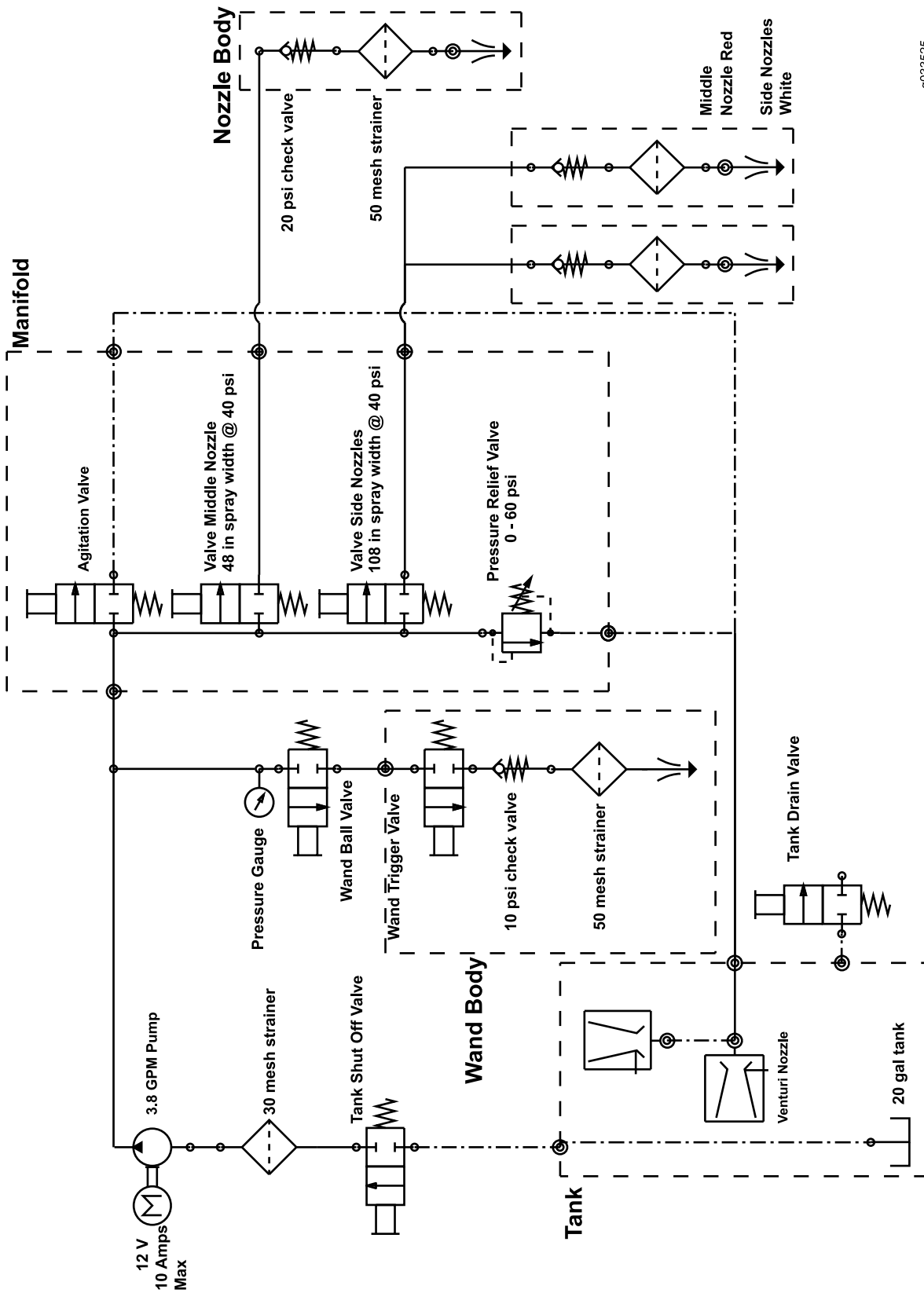

g033525

Sprayer System Schematic (Rev. A)

g033525

# Notes:

# California Proposition 65 Warning Information

## What is this warning?

You may see a product for sale that has a warning label like the following:



**WARNING: Cancer and Reproductive Harm—[www.p65Warnings.ca.gov](http://www.p65Warnings.ca.gov).**

## What is Prop 65?

Prop 65 applies to any company operating in California, selling products in California, or manufacturing products that may be sold in or brought into California. It mandates that the Governor of California maintain and publish a list of chemicals known to cause cancer, birth defects, and/or other reproductive harm. The list, which is updated annually, includes hundreds of chemicals found in many everyday items. The purpose of Prop 65 is to inform the public about exposure to these chemicals.

Prop 65 does not ban the sale of products containing these chemicals but instead requires warnings on any product, product packaging, or literature with the product. Moreover, a Prop 65 warning does not mean that a product is in violation of any product safety standards or requirements. In fact, the California government has clarified that a Prop 65 warning "is not the same as a regulatory decision that a product is 'safe' or 'unsafe.'" Many of these chemicals have been used in everyday products for years without documented harm. For more information, go to <https://oag.ca.gov/prop65/faqs-view-all>.

A Prop 65 warning means that a company has either (1) evaluated the exposure and has concluded that it exceeds the "no significant risk level"; or (2) has chosen to provide a warning based on its understanding about the presence of a listed chemical without attempting to evaluate the exposure.

## Does this law apply everywhere?

Prop 65 warnings are required under California law only. These warnings are seen throughout California in a wide range of settings, including but not limited to restaurants, grocery stores, hotels, schools, and hospitals, and on a wide variety of products. Additionally, some online and mail order retailers provide Prop 65 warnings on their websites or in catalogs.

## How do the California warnings compare to federal limits?

Prop 65 standards are often more stringent than federal and international standards. There are various substances that require a Prop 65 warning at levels that are far lower than federal action limits. For example, the Prop 65 standard for warnings for lead is 0.5 µg/day, which is well below the federal and international standards.

## Why don't all similar products carry the warning?

- Products sold in California require Prop 65 labelling while similar products sold elsewhere do not.
- A company involved in a Prop 65 lawsuit reaching a settlement may be required to use Prop 65 warnings for its products, but other companies making similar products may have no such requirement.
- The enforcement of Prop 65 is inconsistent.
- Companies may elect not to provide warnings because they conclude that they are not required to do so under Prop 65; a lack of warnings for a product does not mean that the product is free of listed chemicals at similar levels.

## Why does Toro include this warning?

Toro has chosen to provide consumers with as much information as possible so that they can make informed decisions about the products they buy and use. Toro provides warnings in certain cases based on its knowledge of the presence of one or more listed chemicals without evaluating the level of exposure, as not all the listed chemicals provide exposure limit requirements. While the exposure from Toro products may be negligible or well within the "no significant risk" range, out of an abundance of caution, Toro has elected to provide the Prop 65 warnings. Moreover, if Toro does not provide these warnings, it could be sued by the State of California or by private parties seeking to enforce Prop 65 and subject to substantial penalties.



**Count on it.**