



**Count on it.**

**Operator's Manual**

**8-Blade, 11-Blade, and 14-Blade  
DPA Cutting Unit**

**Greensmaster® 3150 or 3250-D Series  
Traction Unit**

Model No. 04652—Serial No. 316000001 and Up

Model No. 04654—Serial No. 316000001 and Up

Model No. 04656—Serial No. 316000001 and Up



This product complies with all relevant European directives. For details, please see the Declaration of Incorporation (DOI) at the back of this publication.

**⚠ WARNING**

**CALIFORNIA  
Proposition 65 Warning**

**Use of this product may cause exposure to chemicals known to the State of California to cause cancer, birth defects, or other reproductive harm.**

Model No. \_\_\_\_\_

Serial No. \_\_\_\_\_

This manual identifies potential hazards and has safety messages identified by the safety-alert symbol (Figure 2), which signals a hazard that may cause serious injury or death if you do not follow the recommended precautions.



**Figure 2**

g000502

1. Safety-alert symbol

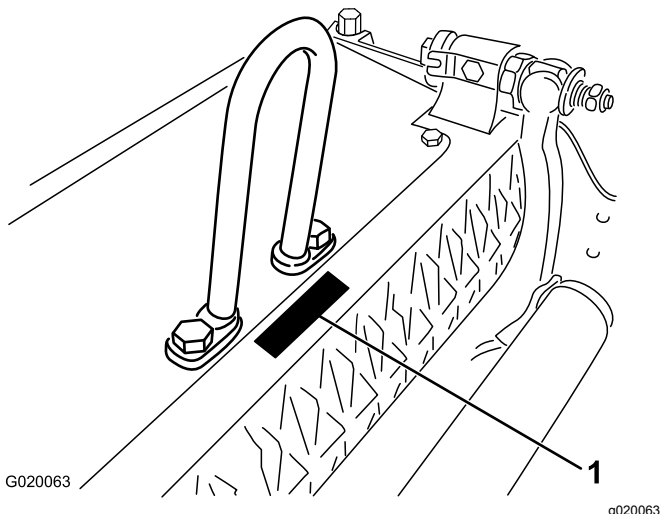
# Introduction

This cutting unit is designed for cutting turf on greens and small fairways of golf courses.

Read this information carefully to learn how to operate and maintain your product properly and to avoid injury and product damage. You are responsible for operating the product properly and safely.

You may contact Toro directly at [www.Toro.com](http://www.Toro.com) for product and accessory information, help finding a dealer, or to register your product.

Whenever you need service, genuine Toro parts, or additional information, contact an Authorized Service Dealer or Toro Customer Service and have the model and serial numbers of your product ready. Figure 1 identifies the location of the model and serial numbers on the product. Write the numbers in the space provided.



**Figure 1**

1. Location of the model and serial numbers

# Contents

Safety .....	3
General Safety .....	3
Safe Operating Practices.....	3
Safety and Instructional Decals .....	4
Setup .....	5
Installing the Roller .....	5
Installing the Ball Studs.....	5
Installing the Hoop Link, Offset Link, or Chain Link.....	5
Repositioning the Counter Weights.....	6
Adjusting the Cutting Unit .....	7
Product Overview .....	8
Specifications .....	8
Attachments/Accessories .....	8
Operation .....	8
Maintenance .....	9
Supporting the Cutting Unit.....	9
Adjusting the Bedknife-to-Reel Contact .....	9
Relief-Grinding the Reel .....	10
Adjusting the Rear-Roller Height.....	11
Adjusting the Height of Cut .....	12
Adjusting the Cut-Off Bar .....	13
Servicing the Bedbar .....	13
Checking the Top Grind Angle.....	15
Reel Grinding Specifications.....	15
Installing the Bedknife.....	16
Backlapping the Cutting Unit.....	17

# Safety

This machine has been designed in accordance with EN ISO 5395:2013 and ANSI B71.1-2012.

## General Safety

This product is capable of amputating hands and feet and of throwing objects. Always follow all safety instructions to avoid serious personal injury.

Using this product for purposes other than its intended use could prove dangerous to you and bystanders.

- Read and understand the contents of this *Operator's Manual* before starting the engine.
- Do not put your hands or feet near moving components of the machine.
- Do not operate the machine without all guards and other safety protective devices in place and working on the machine.
- Keep clear of any discharge opening. Keep bystanders and pets a safe distance away from the machine.
- Keep children out of the operating area. Never allow children to operate the machine.
- Park the machine on a level surface, lower the cutting units, disengage the drives, engage the parking brake (if provided), shut off the engine, and remove the key before leaving the operator's position for any reason.

Improperly using or maintaining this machine can result in injury. To reduce the potential for injury, comply with these safety instructions and always pay attention to the safety-alert symbol ([Figure 2](#)), which means Caution, Warning, or Danger—personal safety instruction. Failure to comply with these instructions may result in personal injury or death.

You can find additional safety information where needed throughout this *Operator's Manual*.

## Safe Operating Practices

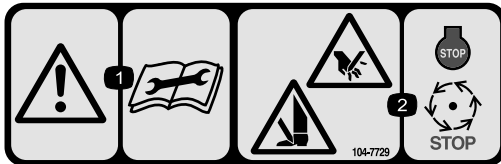
- Read the *Operator's Manual* for the traction unit and other training material carefully. Be familiar with the controls, safety signs, and the proper use of the equipment. If the operator or mechanic cannot read the language of this manual, it is the owner's responsibility to explain this material to them.
- Become familiar with the safe operation of the equipment, operator controls, and safety signs.
- The owner/operator can prevent and is responsible for accidents that may cause personal injury or property damage.

- Wear appropriate clothing, including eye protection; substantial, slip-resistant footwear; long pants, and hearing protection. Tie back long hair and do not wear loose jewelry.
- Inspect the area where the equipment is to be used and remove all objects, such as rocks, toys, and wire, that the machine can throw.
- Check that operator's presence controls, safety switches, and shields are attached and functioning properly. Do not operate the machine unless they are functioning properly.
- Stop the machine, remove the key, and wait for all moving parts to stop before inspecting the attachment after striking an object or if there is an abnormal vibration in the machine. Make all necessary repairs before resuming operation.
- Keep your hands and feet away from the cutting units.
- Keep all parts in good working condition and all hardware tightened. Replace all worn or damaged decals.
- A worn or damaged blade can break, and a piece of the blade could be thrown toward you or bystanders, resulting in serious personal injury or death.
- Inspect the blade periodically for wear or damage.
- Use care when checking the blades. Wrap the blades or wear gloves, and use caution when servicing the blades. Only replace or sharpen the blades; never straighten or weld them.
- On multi-bladed machines, take care as rotating 1 blade can cause other blades to rotate.

## Safety and Instructional Decals



Safety decals and instructions are easily visible to the operator and are located near any area of potential danger. Replace any decal that is damaged or missing.



decal104-7729

**104-7729**

1. Warning—read the instructions before servicing or performing maintenance.
2. Cutting/dismemberment hazard; hand or foot—shut off the engine and wait for moving parts to stop.

# Setup

## Media and Additional Parts

Description	Qty.	Use
Ball stud	2	Mount this to the roller.
Operator's Manual	1	Read before installing and operating the cutting unit.
Parts catalog	1	Use this to reference part numbers.

## Installing the Roller

The cutting unit is shipped without a front roller. Obtain a roller from your dealer and install it on the cutting unit, as follows:

1. Remove the plow bolt, washer, and flange nut securing one of the height-of-cut arms to the cutting unit side plate (Figure 3).

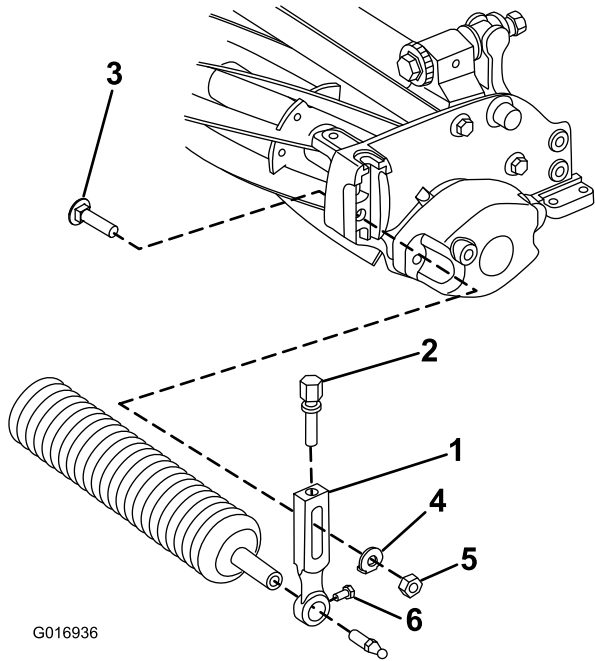


Figure 3

1. Height-of-cut arm
2. Adjusting screw
3. Plow bolt
4. Washer
5. Flange nut
6. Roller-mounting screw

2. Loosen the roller-mounting screws in the height-of-cut arms (Figure 3).
3. Slide the roller shaft into the height-of-cut arm on the opposite end of the cutting unit (Figure 3).
4. Slide the height-of-cut arm onto the roller shaft (Figure 3).
5. Loosely secure the roller to the cutting unit with the height-of-cut arm and fasteners previously removed (Figure 3).

6. Center the roller between the height-of-cut arms.
7. Tighten the roller-mounting screws (Figure 3).
8. Adjust to the desired height-of-cut and tighten the height-of-cut arm mounting fasteners.

## Installing the Ball Studs

Install a ball stud on each end of the front roller (Figure 4).

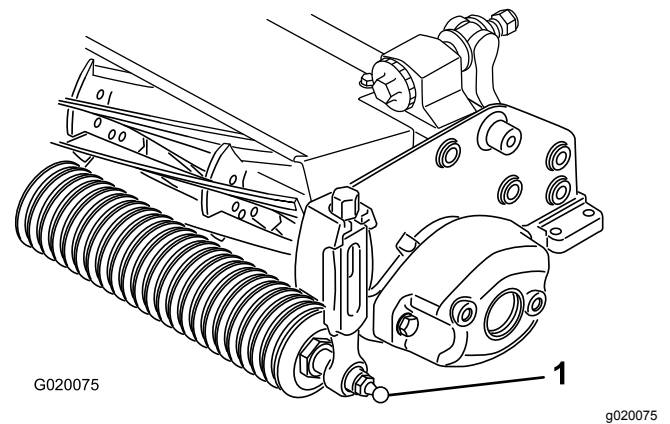


Figure 4

1. Ball stud

## Installing the Hoop Link, Offset Link, or Chain Link

For cutting units mounting on a traction unit with a serial number prior to 240000001, obtain and install the proper lift link as follows:

**Note:** The 2 bolts used to mount the lift link are shipped installed on the cutting unit.

- For Greensmaster 3120 and 3150 traction units, install the hoop link supplied with the traction unit.

Install the hoop link to the top of the cutting unit with 2 bolts. Torque the bolts to 34 to 40 N·m (25 to 30 ft·lb) (Figure 5).

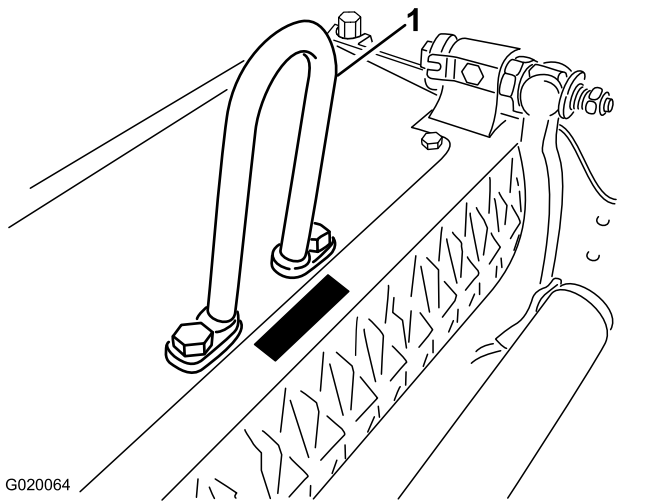


Figure 5

1. Hoop link

- For the Greensmaster 3250-D traction units, install the offset link supplied with the traction unit.

Install the offset link (Figure 6) to the top of the cutting unit with 2 bolts. Torque the bolts to 34 to 40 N·m (25 to 30 ft-lb).

**Important:** Position the lift hook offset toward the front of the cutting unit.

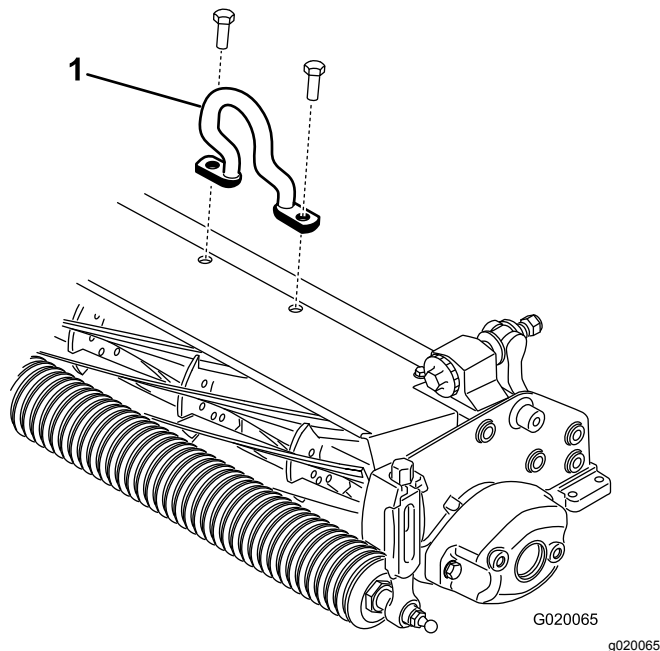


Figure 6

1. Offset lift hook

- Optionally for the Greensmaster 3250-D traction units, you can install the chain Link and mounting bracket available from your authorized Toro distributor.

Install the chain link (Figure 7) to the top of the cutting unit with the mounting bracket and 2 bolts. Torque the bolts to 34 to 40 N·m (25 to 30 ft-lb).

**Note:** When mounting the cutting unit to the traction unit, hook the wider end of the chain link to the lift arm.

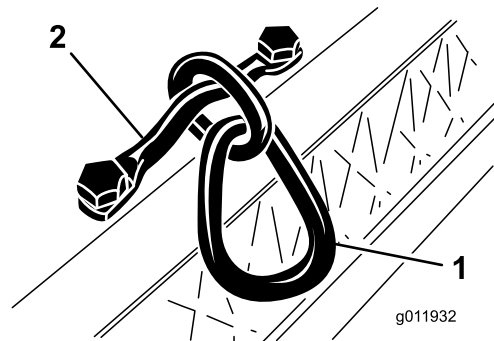


Figure 7

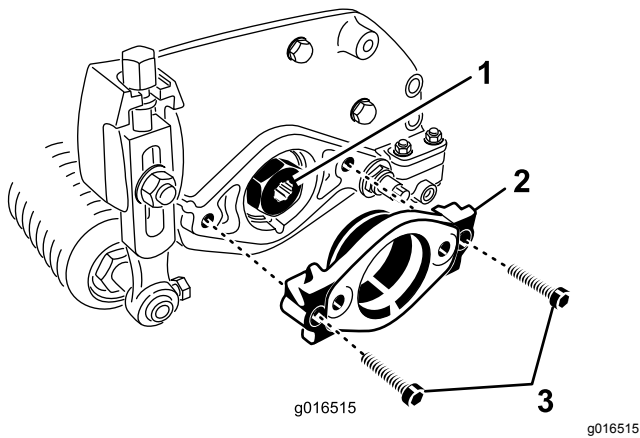
1. Chain link
2. Mounting bracket

## Repositioning the Counter Weights

The cutting units are shipped with the counter weight mounted to the left end and the motor mount to the right end of the cutting unit. To change the cutting unit to different positions, proceed as follows:

**Important:** Whenever you need to tip the cutting unit on its side, ensure that you prop it up to avoid damaging the bedbar-adjusting bolts; refer to [Supporting the Cutting Unit \(page 9\)](#)

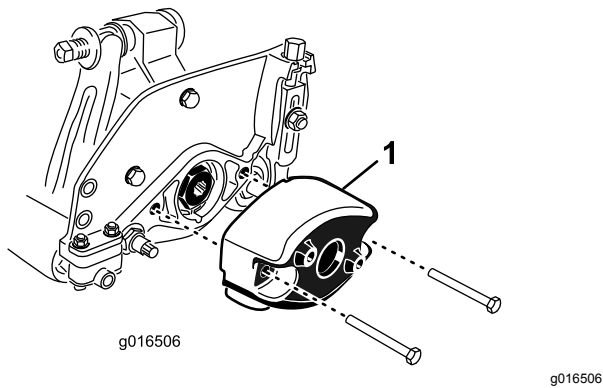
1. Remove the 2 bolts securing the counter weight to the left end of the cutting unit. Remove the counter weight (Figure 9).
2. Remove the 2 Allen head bolts securing the motor mount to the left end of the cutting unit. Remove the motor mount (Figure 8).
3. Apply grease to the inside diameter of the drive spline (Figure 8).
4. On the left end of the cutting unit, apply a light coating of oil to the O-ring and install the motor mount with the 2 Allen head bolts previously removed (Figure 8). Torque the bolts to 16 to 20 N·m (12 to 15 ft-lb).



**Figure 8**

- 1. Drive spline
- 2. Motor mount
- 3. Allen head bolts

- 
- 5. On the right end of the cutting unit, apply a light coating of oil to the O-ring and install the counter weight with the bolts previously removed ([Figure 9](#)). Torque the bolts to 16 to 20 N·m (12 to 15 ft-lb).



**Figure 9**

- 1. Counter weight

---

## Adjusting the Cutting Unit

- 1. Support the cutting unit; refer to [Supporting the Cutting Unit \(page 9\)](#).
- 2. Adjust the bedknife to the reel; refer to [Adjusting the Bedknife-to-Reel Contact \(page 9\)](#).
- 3. Adjust the rear roller height; refer to [Adjusting the Rear-Roller Height \(page 11\)](#).
- 4. Adjust the height of cut; refer to [Adjusting the Height of Cut \(page 12\)](#).
- 5. Adjust the cut-off bar; refer to [Adjusting the Cut-Off Bar \(page 13\)](#).

# Product Overview

## Specifications

Tractors	Greensmaster 3120, 3150, 3250-D, and 3150-Q Traction Units.
Height of Cut	Adjust on the front roller using 2 vertical bolts and held 2 locking bolts.
Height-of-Cut Range	Standard bench height-of-cut range is 1.6 mm (0.062 inch) to 12.7 mm (0.500 inch). Bench height-of-cut range with the High Height of Cut Kit installed is 7 mm (0.285 inch) to 25 mm (1.00 inch). Effective height of cut may vary depending on turf conditions, type of bedknife, rollers, and attachments installed.
Cutting Width	53 cm (21 inches)
Reel Bearings	Two sealed stainless steel, deep groove ball bearings
Rollers	The rear roller is a 5.1 cm (2 inch) diameter steel full roller.
Bedknife	Replaceable single edged, high carbon steel bedknife is fastened to a machined cast iron bedbar with 13 bolts
Bedknife Adjustment	Dual-bolt adjustment to the reel; detents corresponding to 0.018 mm (0.0007 inch) bedknife movement for each indexed position
Grass Shield	Non-adjustable shield with adjustable cut-off bar to improve grass discharge from reel in wet conditions
Counterweight	A cast iron weight mounted opposite to the drive motor balances the cutting unit.
Net Weight	8 Blade—30 kg (65 lb), 11 Blade—31 kg (68 lb), 14 Blade—32 kg (71 lb)

## Attachments/Accessories

A selection of Toro approved attachments and accessories is available for use with the machine to enhance and expand its capabilities. Contact your Authorized Service Dealer or Distributor or go to [www.Toro.com](http://www.Toro.com) for a list of all approved attachments and accessories.

To ensure optimum performance and continued safety certification of the machine, use only genuine Toro replacement parts and accessories. Replacement parts and accessories made by other manufacturers could be dangerous, and such use could void the product warranty.

## Operation

Refer to your traction unit *Operator's Manual* for detailed operation instructions. Before using the cutting unit each day, adjust the bedknife; refer to [Adjusting the Bedknife-to-Reel Contact \(page 9\)](#). Test the quality of cut by cutting a test swath before using the cutting unit on a green to ensure that the finished cut is correct.

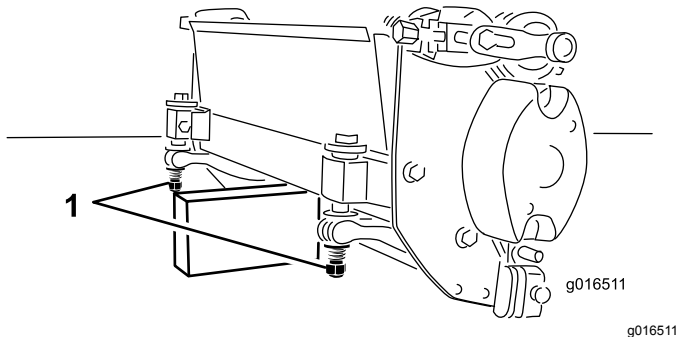


# Maintenance

**Note:** Determine the left and right sides of the machine from the normal operating position.

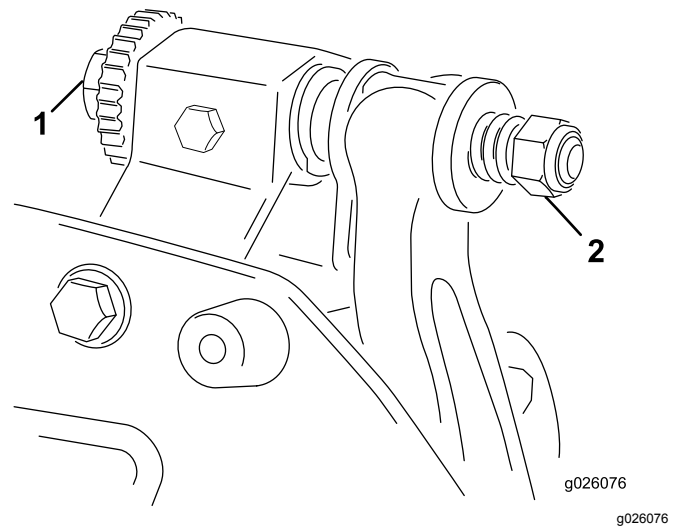
## Supporting the Cutting Unit

Whenever you need to tip the cutting unit to expose the bedknife/reel, prop up the rear of the cutting unit to ensure that the nuts on the back end of the bedbar-adjusting bolts are not resting on the work surface (Figure 10).



**Figure 10**

1. Prop (not provided)
2. Bedbar-adjusting-screw nut (2)



**Figure 11**

1. Bedbar adjusting screw
2. Bedbar-adjusting-screw nut (2)

## Adjusting the Bedknife-to-Reel Contact

### Adjusting the Bedknife Daily

Prior to mowing each day, or as required, verify proper bedknife-to-reel contact. **Perform this procedure even though the quality of cut is acceptable.**

1. Lower the cutting units onto a hard surface, shut off the engine, and remove the ignition key.
2. Slowly rotate the reel in a reverse direction, listening for reel-to-bedknife contact.
  - If no contact is evident, adjust the bedknife as follows:
    - A. Turn the bedbar adjusting screws clockwise (Figure 11), 1 click at a time, until you feel and hear light contact.

**Note:** The bedbar adjusting screws have detents corresponding to 0.018 mm (0.0007 inch) bedknife movement for each indexed position.

- B. Insert a long strip of cutting performance paper between the reel and bedknife, perpendicular to the bedknife (Figure 12), then **slowly** rotate the reel forward; it should cut the paper; if not, repeat steps A and B until it does.

- If excessive contact/reel drag is evident, backlap, reface the front of the bedknife, or grind the cutting unit to achieve the sharp edges needed for precision cutting (Refer to the *Toro Manual for Sharpening Reel and Rotary Mowers*, Form No. 09168SL).

**Important:** Light contact is preferred at all times. If you do not maintain light contact, the bedknife/reel edges will not sufficiently self-sharpen, and dull cutting edges will result after a period of operation. If you maintain excessive contact, bedknife/reel wear will be accelerated, uneven wear can result, and the quality of cut may decline.

**Note:** As the reel blades continue to run against the bedknife, a slight burr will appear on the front cutting edge surface along the full length of the bedknife. Occasionally run a file across the front edge to remove this burr to improve cutting.

After extended running, a ridge will eventually develop at both ends of the bedknife. Round off these notches or file them flush with the cutting edge of the bedknife to ensure smooth operation.

## Adjusting the Bedknife to the Reel

Use this procedure during initial cutting-unit setup and after grinding, backlapping, or disassembling the reel. This **is not** a daily adjustment.

1. Position the cutting unit on a flat, level work surface.
2. Tip the cutting unit to expose the bedknife and reel.

**Note:** Ensure that the nuts on the back of the bedbar adjusting bolts are not resting on the work surface (Figure 10).

3. Rotate the reel so that 1 of the blades crosses the bedknife edge between the first and second bedknife bolt heads located on the right side of the cutting unit.
4. Make an identifying mark on the blade where it crosses the bedknife edge.

**Note:** This will make later adjustments easier.

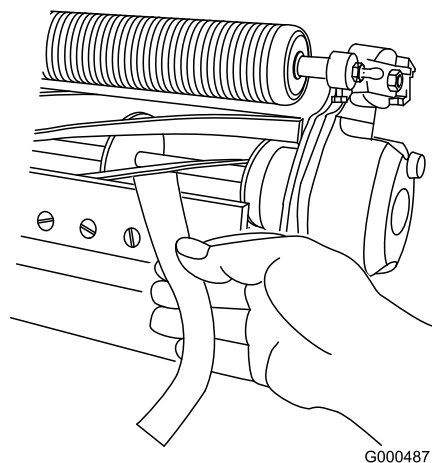
5. Insert a 0.05 mm (0.002 inch) shim between the blade and the bedknife edge at the point marked in step 4.
6. Turn the right bedbar adjusting bolt (Figure 11) until you feel light pressure on the shim when sliding it side-to-side. Remove the shim.
7. For the left side of the cutting unit, slowly rotate the reel so that the closest blade crosses the bedknife edge between the first and second bolt heads.
8. Repeat steps 4 through 6 for the left side of the cutting unit and left bedbar adjusting bolt.
9. Repeat steps 5 and 6 until there is light pressure at the contact points on both the left and right sides of the cutting unit.
10. To obtain light contact between the reel and bedknife, turn each bedbar adjusting bolt clockwise 3 clicks.

**Note:** Each click on the bedbar adjusting bolt moves the bedknife 0.018 mm (0.0007 inches).

**Do not overtighten the adjusting bolts.**

Turning the adjusting bolt clockwise moves the bedknife edge closer to the reel. Turning the adjusting bolt counterclockwise moves the bedknife edge away from the reel.

11. Insert a long strip of cutting performance paper between the reel and bedknife, perpendicular to the bedknife (Figure 12), then **slowly** rotate the reel forward; it should cut the paper; if not, turn each bedbar adjusting bolt clockwise 1 clicks and repeat this step until it cuts the paper.



G000487

g000487

Figure 12

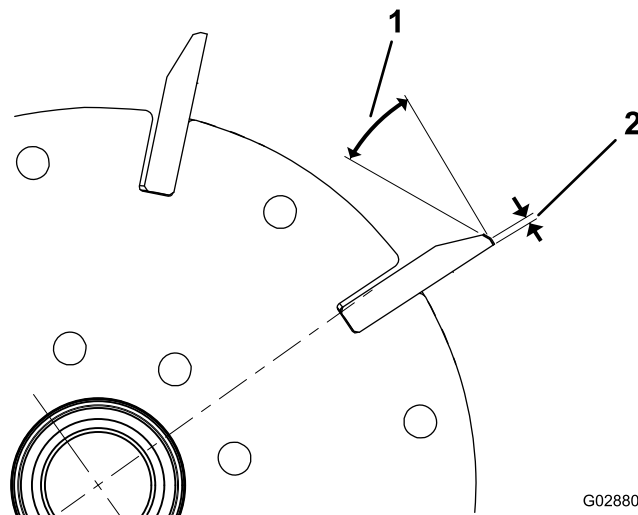
**Note:** If excessive contact/reel drag is evident, backlap, reface the front of the bedknife, or grind the cutting unit to achieve the sharp edges needed for precision cutting (Refer to the *Toro Manual for Sharpening Reel and Rotary Mowers*, Form No. 09168SL).

## Relief-Grinding the Reel

The new reel has a land width of 1.3 to 1.5 mm (0.050 to 0.060 inch) and a 30 degree relief grind.

When the land width gets larger than 3 mm (0.120 inch) wide, do the following:

1. Apply a 30 degree relief grind on all reel blades until the land width is 1.3 mm (0.050 inch) wide (Figure 13 and Figure 14).



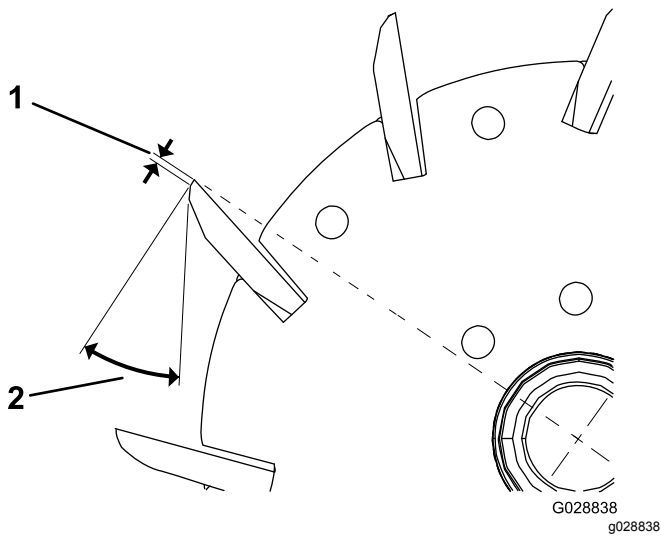
G028800

g028800

Figure 13  
Model 03638

1. 30 degrees

2. 1.3 mm (0.050 inch)



**Figure 14**

Models 03639 and 03641

1. 1.3 mm (0.050 inch)
2. 30 degrees

2. Spin grind the reel to achieve <math><0.025\text{ mm}</math> (0.001 inch) reel run-out.

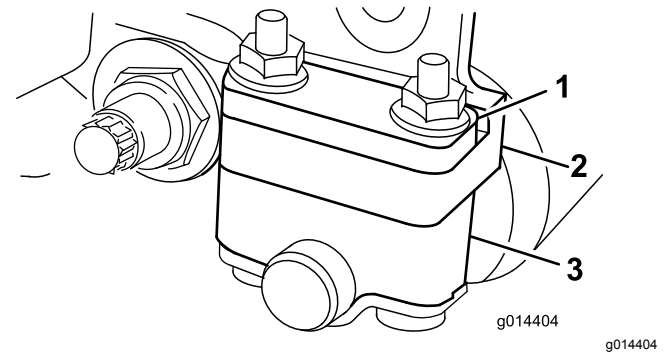
**Note:** This causes the land width to grow slightly.

**Note:** To extend the longevity of the sharpness of the edge of the reel and the bedknife—after grinding the reel and/or the bedknife—check the reel to bedknife contact again after cutting 2 fairways, as any burrs will be removed, which may create improper reel to bedknife clearance and thus accelerate wear.

## Adjusting the Rear-Roller Height

Depending on your desired height-of-cut range, you need to adjust the rear-roller brackets (Figure 15 or Figure 16) to the low or high position:

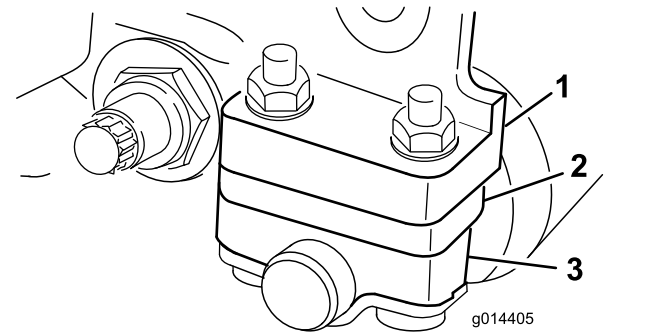
- Position the spacer above the sideplate-mounting flange (factory setting) when the height-of-cut settings range from 1.5 mm to 6 mm (1/16 inch to 1/4 inch) as shown in Figure 15.



**Figure 15**

1. Spacer
2. Sideplate-mounting flange
3. Roller bracket

- Position the spacer below the sideplate-mounting flange when the height-of-cut settings range from 3 mm to 25 mm (1/8 inch to 1 inch) as shown in Figure 16.



**Figure 16**

1. Sideplate-mounting flange
2. Spacer
3. Roller bracket

1. Raise the rear of the cutting unit and place a block under the bedknife.
2. Remove the 2 nuts securing each roller bracket and spacer to each sideplate mounting flange.
3. Lower the roller and bolts from the sideplate mounting flanges and spacers.
4. Place the spacers onto the bolts above or below the roller brackets, as required (Figure 15 or Figure 16).
5. Secure the roller bracket and spacers to the underside of the mounting flanges with the nuts previously removed.

**Note:** The position of the rear roller to the reel is controlled by the machining tolerances of the assembled components and paralleling is not required.

# Adjusting the Height of Cut

Use the following chart to determine which bedknife is best suited for the desired height of cut.

Bedknife	Part No.	Height-of-Cut
Edgemax Micro-cut (Standard)	115-1880	1.5 to 4.7 mm (0.062 to 0.188 inch)
Edgemax Tournament (Optional)	115-1881	3.1 to 12.7 mm (0.125 to 0.500 inch)
Micro-cut (Optional)	93-4262	1.5 to 4.7 mm (0.062 to 0.188 inch)
Tournament (Optional)	93-4263	3.1 to 12.7 mm (0.125 to 0.500 inch)
Extended Micro-cut (Optional)	108-4303	1.5 to 4.7 mm (0.062 to 0.188 inch)
Extended Tournament (Optional)	108-4302	3.1 to 12.7 mm (0.125 to 0.500 inch)
Low-cut (Optional)	93-4264	4.7 to 25.4 mm (0.188 to 1.00 inch)
High-cut (Optional)	94-6392	7.9 to 25.4 mm (0.312 to 1.00 inch)
Fairway (Optional)	63-8600	9.5 to 25.4 mm (0.375 to 1.00 inch)
Fairway EdgeMax (optional)	112-7475	9.5 to 25.4 mm (0.375 to 1.00 inch)

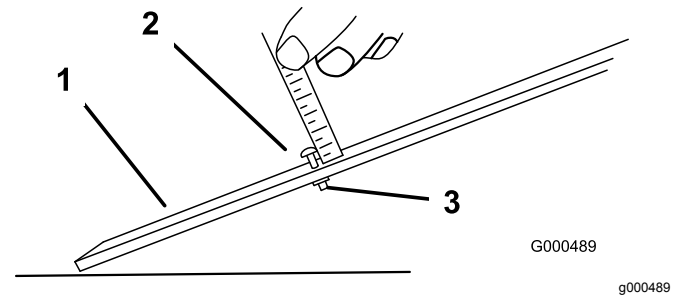
**Note:** For heights of cut greater than 9.5 mm (0.375 inch), install the high-height-of-cut kit.

## Adjusting the Height-of-Cut Gauge

Before adjusting the height of cut, set the height-of-cut gauge as follows:

- Loosen the nut on the gauge bar and set the adjusting bolt to the desired height of cut (Figure 17).

**Note:** The distance between the bottom of the bolt head and the face of bar is the height of cut.



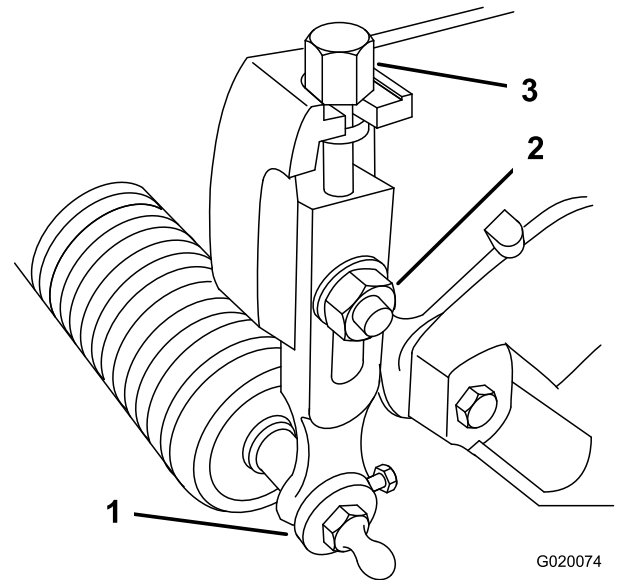
**Figure 17**

- Gauge bar
- Height-adjusting bolt
- Nut

- Tighten the nut.

## Adjusting the Height of Cut

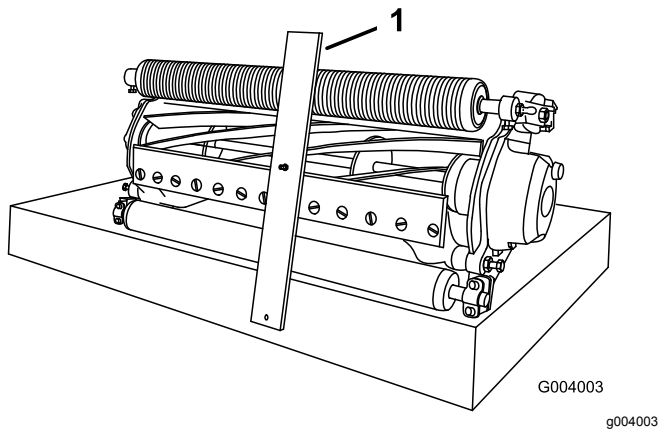
- Loosen the locknuts securing the height-of-cut arms to the cutting-unit side plates (Figure 18).



**Figure 18**

- Height-of-cut arm
- Locknut
- Adjusting bolt

- Hook the bolt head of the height-of-cut gauge onto the right side of the cutting edge of the bedknife and rest the rear end of the bar onto the rear of the roller (Figure 19).



**Figure 19**

1. Gauge bar

3. Rotate the adjusting bolt until the roller contacts the front of the gauge bar.
4. Repeat steps 2 and 3 for the left side.
5. Adjust both ends of the roller until the entire roller is parallel to the bedknife.

**Important:** When set properly, the rear and front rollers will contact the gauge bar and the bolt will be snug against the bedknife. This ensures that the height of cut is identical at both ends of the bedknife.

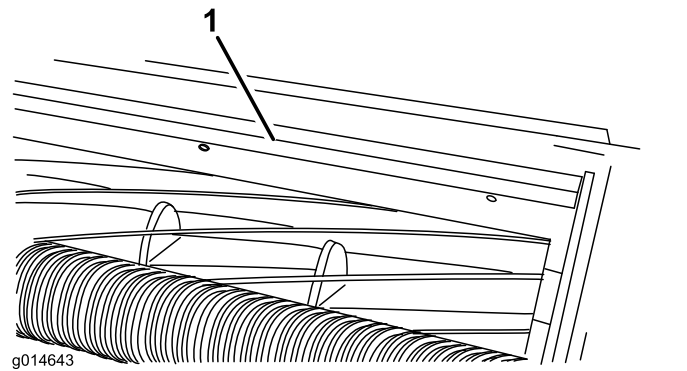
6. Tighten the nuts to secure the adjustment enough to remove play from the washer.
7. Verify that the height-of-cut setting is correct; repeat this procedure if necessary.

## Adjusting the Cut-Off Bar

Adjust the cut-off bar to ensure that the clippings are cleanly discharged from the reel area, as follows:

**Note:** The bar is adjustable to compensate for changes in turf conditions. Adjust the bar closer to the reel when the turf is extremely dry. By contrast, adjust the bar further away from the reel when the turf conditions are wet. The bar should be parallel to the reel to ensure optimum performance. Adjust it after the reel is sharpened on a reel grinder.

1. Loosen the bolts securing the top bar (Figure 20) to the cutting unit.



**Figure 20**

1. Cut-off bar

2. Insert a 1.5 mm (0.060 inch) feeler gauge between the top of the reel and the bar then tighten the bolts.

**Important:** Ensure that the bar and reel are equal distance apart across the complete reel.

**Note:** Adjust the gap as needed for your turf conditions.

## Servicing the Bedbar

Only a properly trained mechanic should service the bedbar and bedknife to prevent damage to the reel, bedbar, or bedknife. Ideally, take the cutting unit to your authorized Toro distributor for service. Refer to the *Service Manual* for your traction unit for complete instructions, special tools, and diagrams for servicing the bedknife. Should you ever need to remove or assemble the bedbar yourself, instructions are provided below, as are the specifications for servicing the bedknife.

**Important:** Always follow the bedknife procedures detailed in your *Service Manual* when servicing the bedknife. Failure to install and grind the bed knife correctly can lead to damage to the reel, bedbar, or bedknife.

## Removing the Bedbar

1. Turn the bedbar adjusting screw, counterclockwise, to back the bedknife away from the reel (Figure 21).

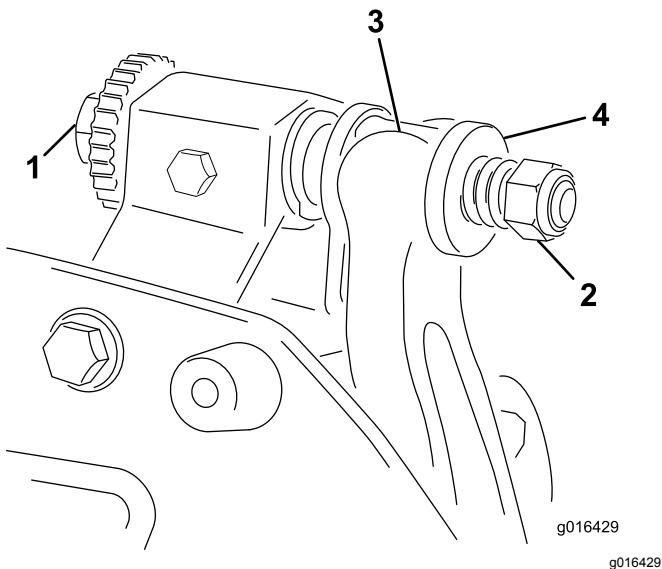


Figure 21

- |                           |           |
|---------------------------|-----------|
| 1. Bedbar-adjusting screw | 3. Bedbar |
| 2. Spring-tension nut     | 4. Washer |

2. Back out the spring-tension nut until the washer is no longer tensioned against the bedbar (Figure 21).
3. On each side of the machine, loosen the locknut securing the bedbar bolt (Figure 22).

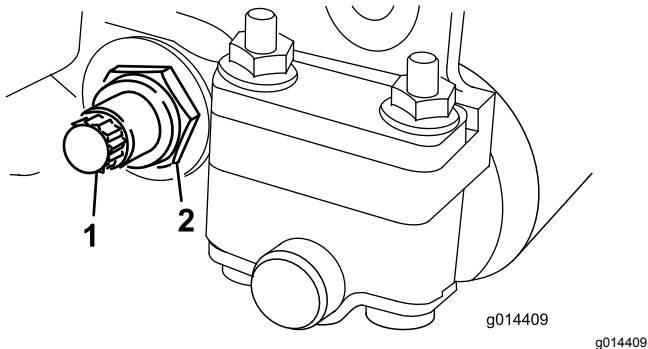


Figure 22

- |                |            |
|----------------|------------|
| 1. Bedbar bolt | 2. Locknut |
|----------------|------------|

4. Remove each bedbar bolt allowing the bedbar to be pulled downward and removed from the cutting unit (Figure 22).

Account for the 2 nylon washers and 1 steel washer on each end of the bedbar (Figure 23).

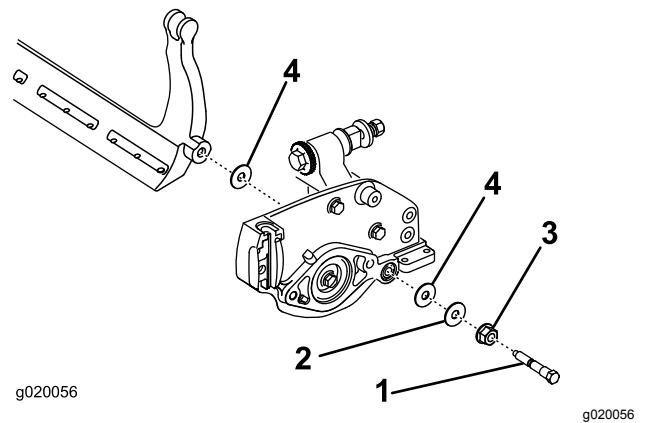


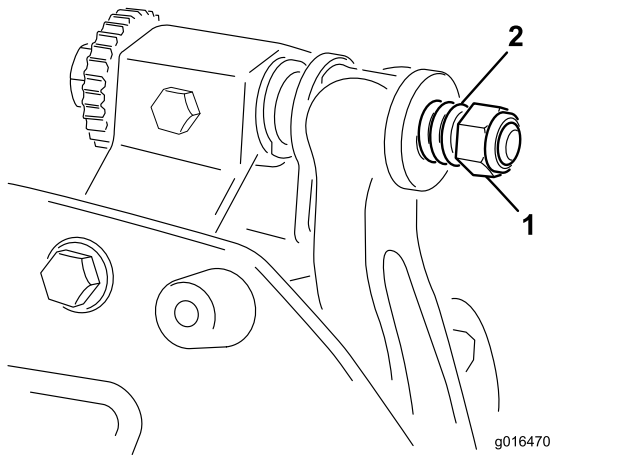
Figure 23

- |                |                 |
|----------------|-----------------|
| 1. Bedbar bolt | 3. Nylon washer |
| 2. Nut         | 4. Steel washer |

## Assembling the Bedbar

1. Install the bedbar, positioning the mounting ears between the washers and the bedbar-adjusting screw (Figure 21).
  2. Secure the bedbar to each side plate with the bedbar bolts (nuts on bolts) and 3 washers (6 total).
  3. Position a nylon washer on each side of the side-plate boss. Place a steel washer outside each of the nylon washers (Figure 23).
  4. Torque the bedbar bolts to 27 to 36 N·m (240 to 320 inch-lb).
  5. Tighten the locknuts until you remove the end play from steel washers, but you are able to rotate them by hand. The washers on the inside may have a gap.
- Important:** Do not overtighten the locknuts or they will deflect the side plates.
6. Tighten the spring tension nut until the spring is collapsed, then back it off 1/2 turn (Figure 24).

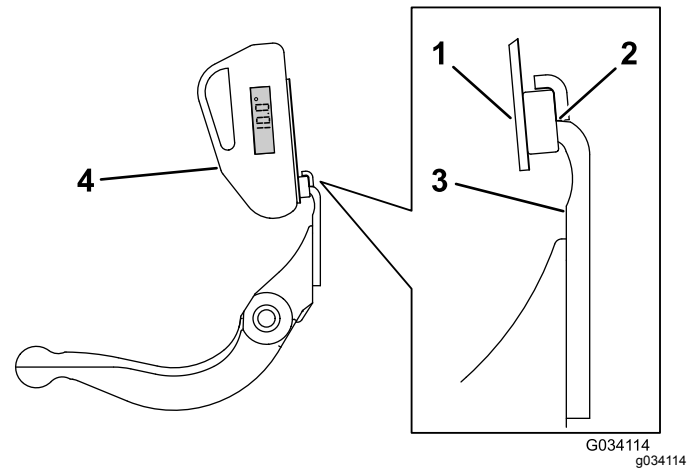




**Figure 24**

1. Spring-tension nut
2. Spring

7. Adjust the bedknife to the reel; refer to [Adjusting the Bedknife-to-Reel Contact](#) (page 9).



**Figure 26**

1. Angle-indicator mount
2. Edge of the magnet mated with the edge of the bedknife
3. Bedknife
4. Angle indicator

4. Place the angle indicator on the mount as shown in [Figure 26](#).

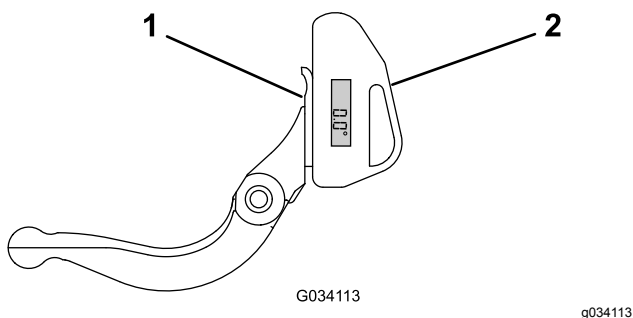
**Note:** This is the angle that your grinder produces, and should be within 2 degrees of the recommended top grind angle.

## Checking the Top Grind Angle

The angle that you use to grind your bedknives is very important.

Use the angle indicator and the angle-indicator mount to check the angle that your grinder produces and then correct for any grinder inaccuracy.

1. Place the angle indicator on the bottom side of the bedknife as shown in [Figure 25](#).



**Figure 25**

1. Bedknife (vertical)
2. Angle indicator

2. Press the Alt Zero button on the angle indicator.
3. Place the angle-indicator mount on the edge of the bedknife so that the edge of the magnet mates with the edge of the bedknife ([Figure 26](#)).

**Note:** The digital display should be visible from the same side during this step as it was in step 1.

## Reel Grinding Specifications

Reel Diameter (New)	128.5 mm (5.06 inches)
Service Limit - Reel Diameter	114.3 mm (4.50 inches)
Reel Shaft Diameter (OD)	34.9 mm (1.375 inches)
Blade Relief Angle	30°
Blade Relief Angle Range	28–32°
Blade Land Width	1 mm (0.040 inch)
Blade Land Width Range	0.8 to 1.2 mm (0.030 to 0.050 inch)
Service Limit - Reel Diameter Taper	0.25 mm (0.010 inch)

# Installing the Bedknife

1. Remove the rust, scale, and corrosion from the bedbar surface and apply a thin layer of oil to the bedbar surface.
2. Clean the screw threads.
3. Apply thread-locking compound to the screws and install the bedknife to the bedbar.

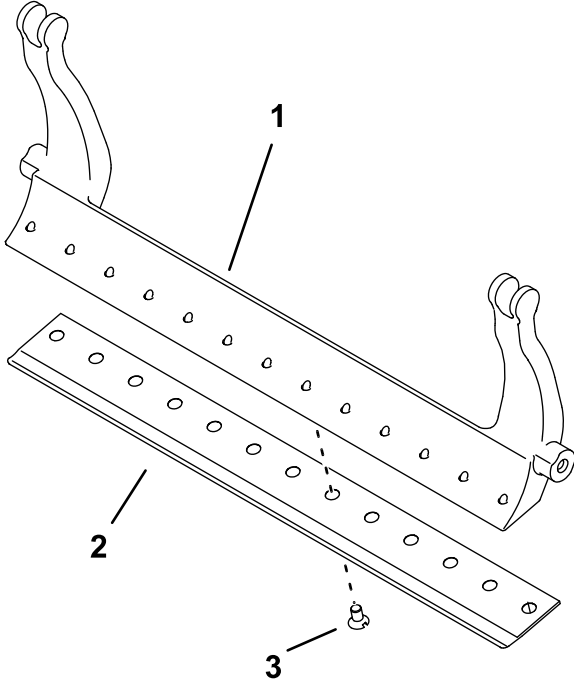
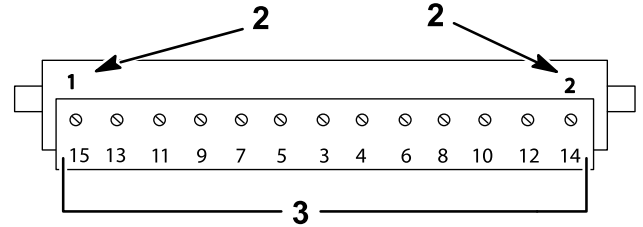
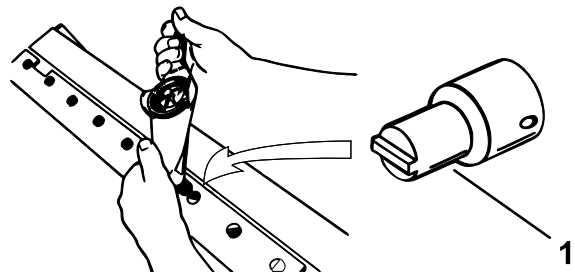


Figure 27

g255045

1. Bedbar
2. Bedknife
3. Screw

4. Torque the 2 outer screws to 1 N·m (10 in-lb).
5. Working from the center of the bedknife, torque the screws to 23 to 28 N·m (200 to 250 in-lb).



g255046

Figure 28

1. Bedknife screw tool
2. Install and torque these first to 1 N·m (10 in-lb).
3. Torque to 23 to 28 N·m (200 to 250 in-lb).

6. Grind the bedknife.

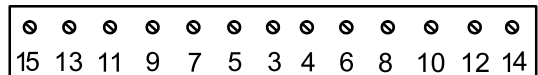
## Bedknife Specifications

### Bedknife Screws

Torque: 23 to 28 N·m (200 to 250 in-lb)

Installation tool: TOR510880

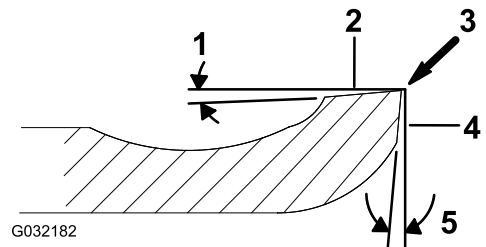
Installation order:



g254874

Figure 29

### Bedknife Grinding Specifications



G032182

g032182

Figure 30

1. Relief angle
2. Top face
3. Remove burr
4. Front face
5. Front angle



Standard bedknife relief angle	3° minimum
Extended bedknife relief angle	7° minimum
Front Angle Range	13° to 17°

## Backlapping the Cutting Unit

### **⚠ DANGER**

Contact with the reel or other moving parts can result in personal injury.

Keep your fingers, hands, and clothing away from the reels or other moving parts.

- Stay away from the reel while backlapping.
- Never use a short handled paint brush for backlapping. Part No. 29-9100 Handle assembly complete or individual parts are available from your local authorized Toro distributor.

1. Position the machine on a clean, level surface, lower the cutting units, stop the engine, engage the parking brake, and remove the ignition key.
2. Remove the reel motors from the cutting units and disconnect and remove the cutting units from the lift arms.
3. Connect the backlapping machine to the cutting unit by inserting a piece of 3/8 inch square stock into the splined coupling in the end of the cutting unit.

**Note:** Additional instructions and procedures on Backlapping are available in your traction unit *Operator's Manual* and the *Toro Sharpening Reel and Rotary Mowers Manual*, Form Number 80-300PT.

**Note:** For a better cutting edge, run a file across the front face of the bedknife and reel when the lapping operation is completed. This will remove any burrs or rough edges that may have built up on the cutting edge.

**Notes:**

# Declaration of Incorporation

The Toro Company, 8111 Lyndale Ave. South, Bloomington, MN, USA declares that the following unit(s) conform(s) to the directives listed, when installed in accordance with the accompanying instructions onto certain Toro models as indicated on the relevant Declarations of Conformity.

Model No.	Serial No.	Product Description	Invoice Description	General Description	Directive
04652	316000001 and Up	8-Blade DPA Reel Mower	8 BLADE CUTTING UNIT NG DPA	8-Blade DPA Reel Mower	2006/42/EC, 2000/14/EC
04654	316000001 and Up	11-Blade DPA Reel Mower	11 BLADE CUTTING UNIT NG DPA	11-Blade DPA Reel Mower	2006/42/EC, 2000/14/EC
04656	316000001 and Up	14-Blade DPA Reel Mower	14 BLADE CUTTING UNIT NG DPA	14-Blade DPA Reel Mower	2006/42/EC, 2000/14/EC

Relevant technical documentation has been compiled as required per Part B of Annex VII of 2006/42/EC.

We will undertake to transmit, in response to requests by national authorities, relevant information on this partly completed machinery. The method of transmission shall be electronic transmittal.

This machinery shall not be put into service until incorporated into approved Toro models as indicated on the associated Declaration of Conformity and in accordance with all instructions, whereby it can be declared in conformity with all relevant Directives.

Certified:



John Heckel  
Sr. Engineering Manager  
8111 Lyndale Ave. South  
Bloomington, MN 55420, USA  
May 9, 2018

Authorized Representative:

Marcel Dutrieux  
Manager European Product Integrity  
Toro Europe NV  
Nijverheidsstraat 5  
2260 Oevel  
Belgium

Tel. +32 16 386 659



# The Toro Warranty

## A Two-Year Limited Warranty

### Conditions and Products Covered

The Toro Company and its affiliate, Toro Warranty Company, pursuant to an agreement between them, jointly warrant your Toro Commercial product ("Product") to be free from defects in materials or workmanship for two years or 1500 operational hours\*, whichever occurs first. This warranty is applicable to all products with the exception of Aerators (refer to separate warranty statements for these products). Where a warrantable condition exists, we will repair the Product at no cost to you including diagnostics, labor, parts, and transportation. This warranty begins on the date the Product is delivered to the original retail purchaser.

\* Product equipped with an hour meter.

### Instructions for Obtaining Warranty Service

You are responsible for notifying the Commercial Products Distributor or Authorized Commercial Products Dealer from whom you purchased the Product as soon as you believe a warrantable condition exists. If you need help locating a Commercial Products Distributor or Authorized Dealer, or if you have questions regarding your warranty rights or responsibilities, you may contact us at:

Toro Commercial Products Service Department  
Toro Warranty Company  
8111 Lyndale Avenue South  
Bloomington, MN 55420-1196  
952-888-8801 or 800-952-2740  
E-mail: commercial.warranty@toro.com

### Owner Responsibilities

As the Product owner, you are responsible for required maintenance and adjustments stated in your *Operator's Manual*. Failure to perform required maintenance and adjustments can be grounds for disallowing a warranty claim.

### Items and Conditions Not Covered

Not all product failures or malfunctions that occur during the warranty period are defects in materials or workmanship. This warranty does not cover the following:

- Product failures which result from the use of non-Toro replacement parts, or from installation and use of add-on, or modified non-Toro branded accessories and products. A separate warranty may be provided by the manufacturer of these items.
- Product failures which result from failure to perform recommended maintenance and/or adjustments. Failure to properly maintain your Toro product per the Recommended Maintenance listed in the *Operator's Manual* can result in claims for warranty being denied.
- Product failures which result from operating the Product in an abusive, negligent, or reckless manner.
- Parts subject to consumption through use unless found to be defective. Examples of parts which are consumed, or used up, during normal Product operation include, but are not limited to, brake pads and linings, clutch linings, blades, reels, rollers and bearings (sealed or greasable), bed knives, spark plugs, castor wheels and bearings, tires, filters, belts, and certain sprayer components such as diaphragms, nozzles, and check valves, etc.
- Failures caused by outside influence. Conditions considered to be outside influence include, but are not limited to, weather, storage practices, contamination, use of unapproved fuels, coolants, lubricants, additives, fertilizers, water, or chemicals, etc.
- Failure or performance issues due to the use of fuels (e.g. gasoline, diesel, or biodiesel) that do not conform to their respective industry standards.

### Countries Other than the United States or Canada

Customers who have purchased Toro products exported from the United States or Canada should contact their Toro Distributor (Dealer) to obtain guarantee policies for your country, province, or state. If for any reason you are dissatisfied with your Distributor's service or have difficulty obtaining guarantee information, contact the Toro importer.

- Normal noise, vibration, wear and tear, and deterioration.
- Normal "wear and tear" includes, but is not limited to, damage to seats due to wear or abrasion, worn painted surfaces, scratched decals or windows, etc.

### Parts

Parts scheduled for replacement as required maintenance are warranted for the period of time up to the scheduled replacement time for that part. Parts replaced under this warranty are covered for the duration of the original product warranty and become the property of Toro. Toro will make the final decision whether to repair any existing part or assembly or replace it. Toro may use remanufactured parts for warranty repairs.

### Deep Cycle and Lithium-Ion Battery Warranty:

Deep cycle and Lithium-Ion batteries have a specified total number of kilowatt-hours they can deliver during their lifetime. Operating, recharging, and maintenance techniques can extend or reduce total battery life. As the batteries in this product are consumed, the amount of useful work between charging intervals will slowly decrease until the battery is completely worn out. Replacement of worn out batteries, due to normal consumption, is the responsibility of the product owner. Battery replacement may be required during the normal product warranty period at owner's expense. Note: (Lithium-Ion battery only): A Lithium-Ion battery has a part only prorated warranty beginning year 3 through year 5 based on the time in service and kilowatt hours used. Refer to the *Operator's Manual* for additional information.

### Maintenance is at Owner's Expense

Engine tune-up, lubrication, cleaning and polishing, replacement of filters, coolant, and completing recommended maintenance are some of the normal services Toro products require that are at the owner's expense.

### General Conditions

Repair by an Authorized Toro Distributor or Dealer is your sole remedy under this warranty.

**Neither The Toro Company nor Toro Warranty Company is liable for indirect, incidental or consequential damages in connection with the use of the Toro Products covered by this warranty, including any cost or expense of providing substitute equipment or service during reasonable periods of malfunction or non-use pending completion of repairs under this warranty. Except for the Emissions warranty referenced below, if applicable, there is no other express warranty. All implied warranties of merchantability and fitness for use are limited to the duration of this express warranty.**

Some states do not allow exclusions of incidental or consequential damages, or limitations on how long an implied warranty lasts, so the above exclusions and limitations may not apply to you. This warranty gives you specific legal rights, and you may also have other rights which vary from state to state.

### Note regarding engine warranty:

The Emissions Control System on your Product may be covered by a separate warranty meeting requirements established by the U.S. Environmental Protection Agency (EPA) and/or the California Air Resources Board (CARB). The hour limitations set forth above do not apply to the Emissions Control System Warranty. Refer to the Engine Emission Control Warranty Statement supplied with your product or contained in the engine manufacturer's documentation for details