



Count on it.

Form No. 3423-882 Rev A

Operator's Manual

Topdresser 2500

Model No. 44507—Serial No. 403310001 and Up

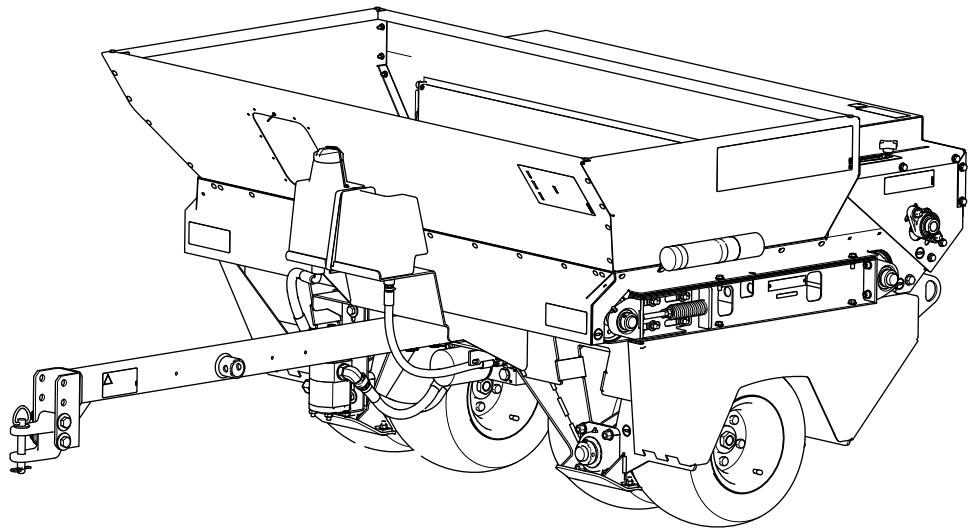

This product complies with all relevant European directives, for details please see the separate product specific Declaration of Conformity (DOC) sheet.

⚠ WARNING

CALIFORNIA
Proposition 65 Warning

Use of this product may cause exposure to chemicals known to the State of California to cause cancer, birth defects, or other reproductive harm.

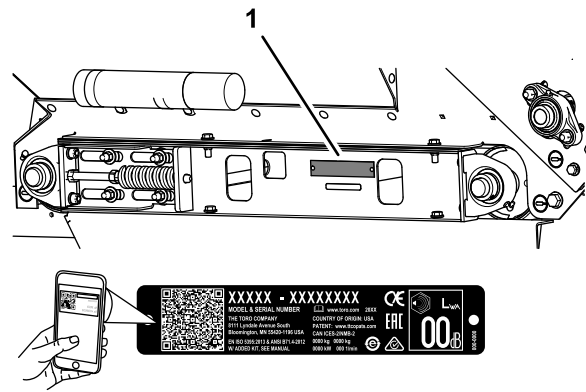

g269187

Figure 1

1. Model and serial number location

Introduction

This machine is intended to be used by professional, hired operators in commercial applications. It is primarily designed for transporting, metering, and applying top-dressing materials.

Using this product for purposes other than its intended use could prove dangerous to you and bystanders.

Read this information carefully to learn how to operate and maintain your product properly and to avoid injury and product damage. You are responsible for operating the product properly and safely.

Visit www.Toro.com for product safety and operation training materials, accessory information, help finding a dealer, or to register your product.

Whenever you need service, genuine Toro parts, or additional information, contact an Authorized Service Dealer or Toro Customer Service and have the model and serial numbers of your product ready. [Figure 1](#) identifies the location of the model and serial numbers on the product. Write the numbers in the space provided.

Important: With your mobile device, you can scan the QR code (if equipped) on the serial number plate to access warranty, parts, and other product information.

This manual identifies potential hazards and has safety messages identified by the safety-alert symbol ([Figure 2](#)), which signals a hazard that may cause serious injury or death if you do not follow the recommended precautions.



g000502

Figure 2

1. Safety-alert symbol

This manual uses 2 words to highlight information. **Important** calls attention to special mechanical information and **Note** emphasizes general information worthy of special attention.

Contents

Safety	4	Changing the Hydraulic Fluid	28
General Safety	4	Replacing the Hydraulic Filter	29
Safety and Instructional Decals	4	Checking the Hydraulic Lines and Hoses.....	29
Setup	7	Brush Maintenance	29
1 Special Instructions for Workman and other Traction Units.....	7	Checking the Brush for Position and Wear	29
2 Installing the CE Decal.....	7	Adjusting the Brush Position	29
3 Installing the Tongue.....	8	Cleaning	30
4 Assembling the Hitch to the Traction-Unit Drawbar	9	Storage	31
5 Mounting the Optional Tongue Jack	9	Troubleshooting	32
6 Installing the Wire Harness	10	Schematics	33
7 Mounting the Skids	10		
Product Overview	11		
Controls	11		
Specifications	12		
Required Attachments.....	12		
Optional Accessories.....	12		
Recommended Accessories.....	12		
Attachments/Accessories.....	12		
Before Operation	13		
Before Operation Safety	13		
Checking the Machine Before Operations	13		
During Operation	13		
During Operation Safety	13		
Slope Safety	14		
Operating the Machine	15		
Loading the Hopper	15		
Sand Application Rate	15		
Sand Precautions	15		
Preparing for Cold Weather Operation	16		
Operating Tips	16		
After Operation	18		
After Operation Safety	18		
Maintenance	19		
Maintenance Safety.....	19		
Recommended Maintenance Schedule(s)	19		
Pre-Maintenance Procedures	19		
Preparing for Maintenance	19		
Raising the Machine	19		
Lubrication	20		
Grease Specification	20		
Greasing the Bearings and Bushings.....	20		
Drive System Maintenance	21		
Checking the Tire Air Pressure.....	21		
Torqueing the Wheel Bolts	21		
Tensioning the Wheel-Drive Chain.....	21		
Tensioning the Conveyor-Belt Chain.....	22		
Belt Maintenance	23		
Tensioning the Conveyor Belt	23		
Replacing the Conveyor Belt	23		
Hydraulic System Maintenance	27		
Hydraulic System Safety.....	27		
Hydraulic Fluid Specification.....	27		
Checking the Hydraulic Fluid Level	28		

Safety

General Safety

This product is capable of causing personal injury. Always follow all safety instructions to avoid serious personal injury.

- Read and understand the contents of this *Operator's Manual* before using this machine. Ensure that everyone using this product knows how to use it and understands the warnings.
- Do not put your hands or feet near moving components of the machine.
- Do not operate the machine without all guards and other safety protective devices in place and working on the machine.

- Keep the machine a safe distance away from bystanders while it is moving.
- Keep children out of the operating area. Never allow children to operate the machine.
- Park the machine on a level surface; engage the parking brake; shut off the traction-unit engine; remove the key; and wait for all movement to stop before servicing or unclogging the machine.

Improperly using or maintaining this machine can result in injury. To reduce the potential for injury, comply with these safety instructions and always pay attention to the safety-alert symbol **▲**, which means Caution, Warning, or Danger—personal safety instruction. Failure to comply with these instructions may result in personal injury or death.

You can find additional safety information where needed throughout this manual.

Safety and Instructional Decals



Safety decals and instructions are easily visible to the operator and are located near any area of potential danger. Replace any decal that is damaged or missing.



58-6520

decal58-6520

1. Grease

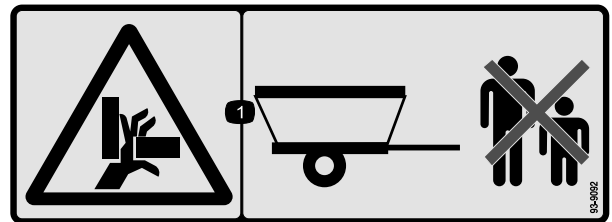

93-9092

decal93-9092

1. Crushing hazard of hand—keep bystanders away.



98-3114

decal98-3114

1. Entanglement hazard—stay away from moving parts; keep all guards in place.



100-7679

decal100-7679

1. Warning—do not disconnect a trailer with an unbalanced load; it may swing up or down and injure you.
2. Read the *Operator's Manual*—do not disconnect the trailer without using a jack stand.

Decal 105-0698 is for CE products.

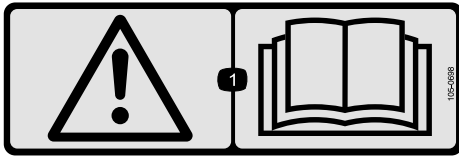

decal105-0698

105-0698

1. Warning—read the *Operator's Manual*.



decal105-0707

105-0707

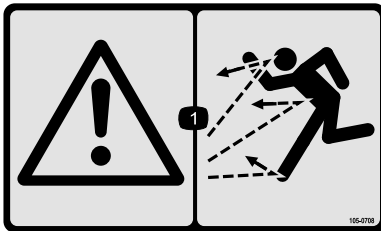

decal105-0708

105-0708

1. Warning—thrown object hazard

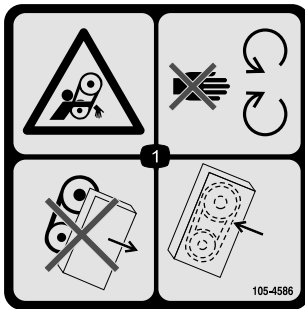

decal105-4586

105-4586

1. Entanglement hazard, belt—stay away from moving parts. Do not operate the machine with the shields or guards removed; keep the shields and guards in place.

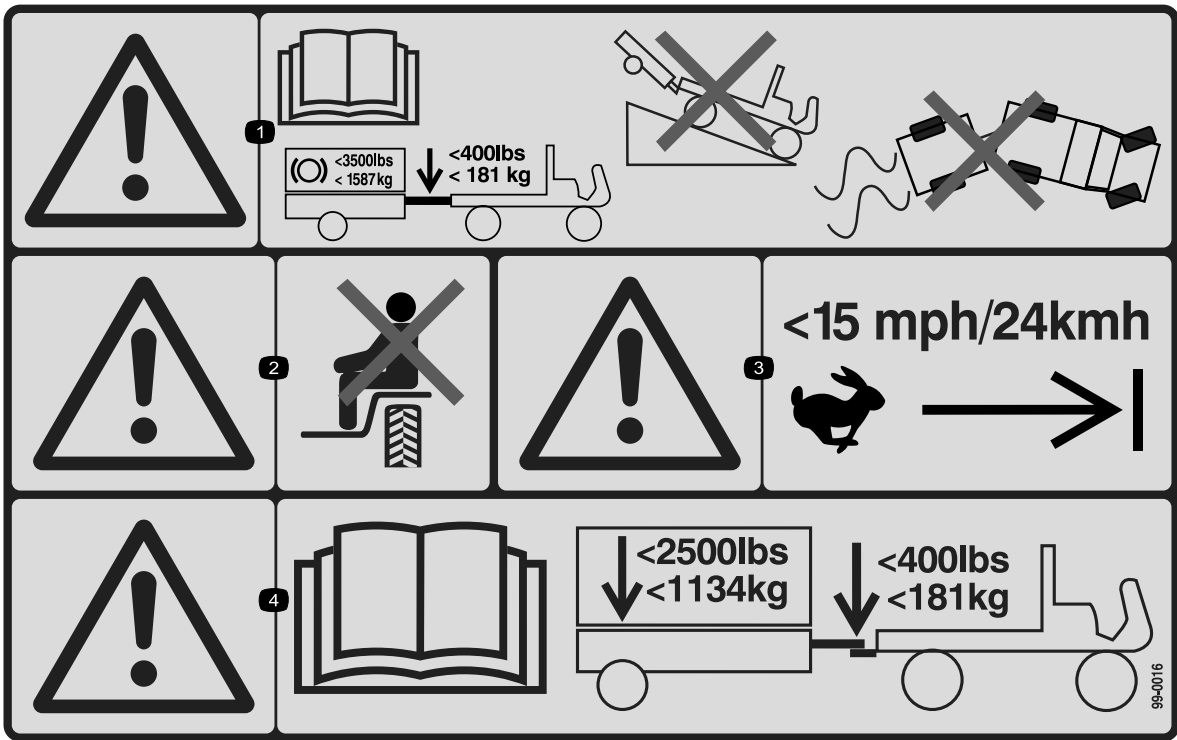

decal99-0016

99-0016

1. Warning—read the *Operator's Manual*; the maximum braking load is 1,587 kg (3,500 lb); the maximum tongue weight is 181 kg (400 lb); do not drive the vehicle with a trailer down a hill; do not lose control of the vehicle and trailer.
2. Warning—do not carry passengers.
3. Warning—do not exceed 24 km/h (15 mph).
4. Warning—read the *Operator's Manual*; the maximum trailer weight is 1,134 kg (2,500 lb); the maximum tongue weight is 181 kg (400 lb).



decal106-7750

106-7750

1. Entanglement hazard of the arm—keep bystanders away; do not carry passengers.

WARNING: Cancer and Reproductive Harm - www.P65Warnings.ca.gov.
For more information, please visit www.tcoCAProp65.com

133-8061

decal133-8061

133-8061

Setup

Loose Parts

Use the chart below to verify that all parts have been shipped.

Procedure	Description	Qty.	Use
1	No parts required	–	Special instructions for workman and other traction units (tractors).
2	CE decal	1	Install the CE decal.
3	Tongue Assembly Lynch Pin Clevis Pin	1 4 2	Install the tongue.
4	No parts required	–	Assemble the hitch to the traction-unit drawbar.
5	Jack (optional)	1	Mount optional tongue jack,
6	Wire harness assembly (topdresser harness, controller harness, and tow-vehicle harness)	1	Install wire harness.
7	Skid Carriage bolt Flat washer Locknut	4 8 8 8	Mount the skids.

Media and Additional Parts

Description	Qty.	Use
Operator's Manual	1	View before operating the machine
Certificate of Compliance	1	CE Certification

1

Special Instructions for Workman and other Traction Units

- For operation over golf greens, most traction units equipped with flotation tires can tow the machine.
- A 4WD traction unit is best for hilly or bermed approaches to greens.
- Trailer brakes are highly recommended when using the machine on hilly terrain. A special trailer brake kit is available for the Workman vehicle. You can adapt this kit other traction units with a 12 volt brake light source.

No Parts Required

Procedure

Important: Use a traction unit with a hitch and brakes rated to 680 kg (1500 lb).

Note: For improved traction and when towing the machine, add weight to the bed of the traction unit.

2

Installing the CE Decal

Parts needed for this procedure:

1	CE decal
---	----------

Procedure

1. Clean the surface of the caution decal (Figure 3).

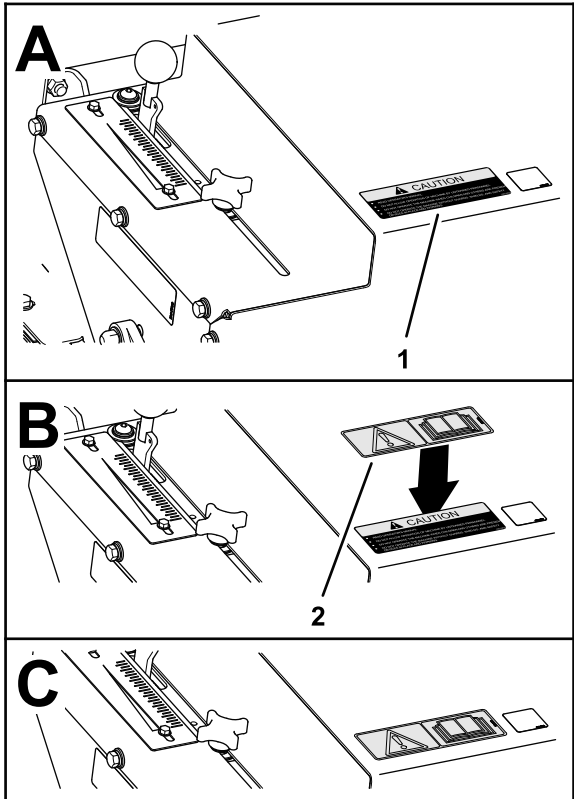

Figure 3

g270554

1. Caution decal
2. CE decal

2. Remove the backing from the CE decal.
3. Apply the CE decal over the caution decal.

3

Installing the Tongue

Parts needed for this procedure:

1	Tongue Assembly
4	Lynch Pin
2	Clevis Pin

Procedure

1. Insert the tongue through the front receiver tube, through the frame of the machine and through the rear receiver tube (Figure 4).

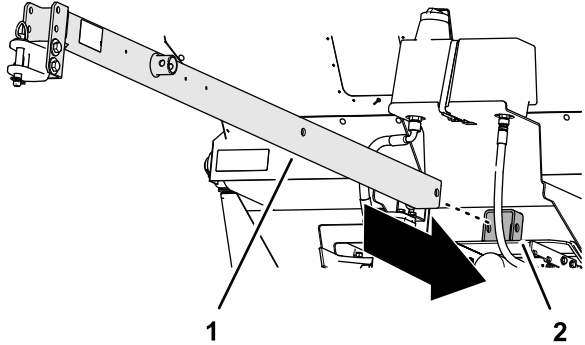

g269253

Figure 4

1. Tongue
2. Front receiver tube

2. Align the holes in the tongue with the holes in the receiver tubes, and secure the tongue to the tubes with the 2 clevis pins and 4 lynch pins (Figure 5).

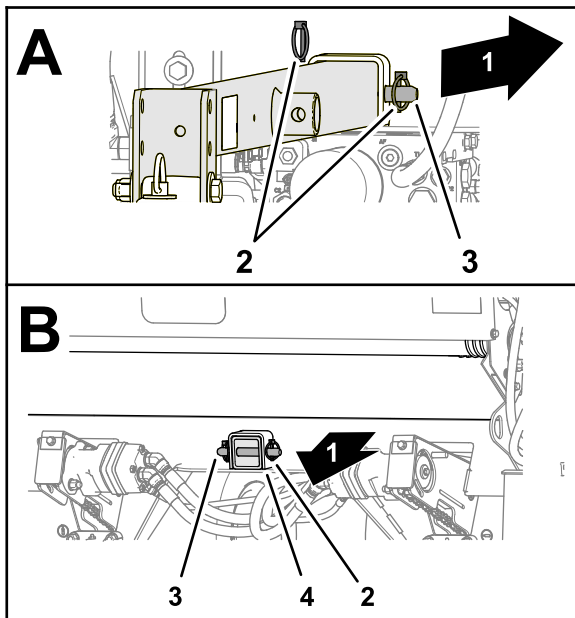

Figure 5

1. Back of the machine
2. Lynch pins
3. Clevis pin
4. Rear receiver tube

4

Assembling the Hitch to the Traction-Unit Drawbar

No Parts Required

Procedure

1. Adjust the position of the hitch clevis to the tongue so that the tongue is level with the drawbar of the traction unit ([Figure 6](#)).

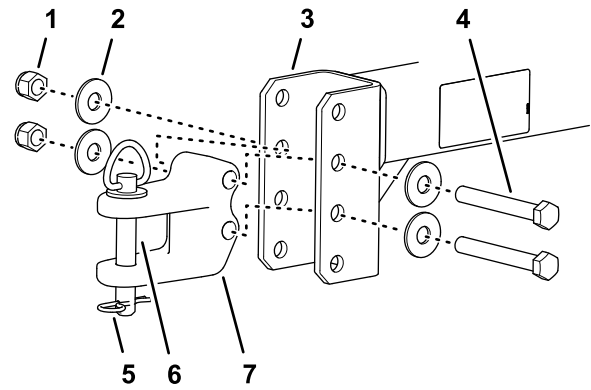

Figure 6

1. Locknut
2. Washer
3. Tongue
4. Capscrew
5. Hairpin
6. Hitch pin
7. Hitch clevis

2. Assemble the hitch clevis to the tongue with the 2 capscrews, 4 washers, and 2 locknuts ([Figure 6](#)).
3. Torque the capscrews and locknuts to 183 to 223 N·m (135 to 165 ft lb).
4. Secure the hitch to the drawbar with the hitch pin and hairpin ([Figure 6](#)).

5

Mounting the Optional Tongue Jack

Parts needed for this procedure:

1	Jack (optional)
---	-----------------

Procedure

1. Slide jack onto mounting tube on tongue ([Figure 7](#)).

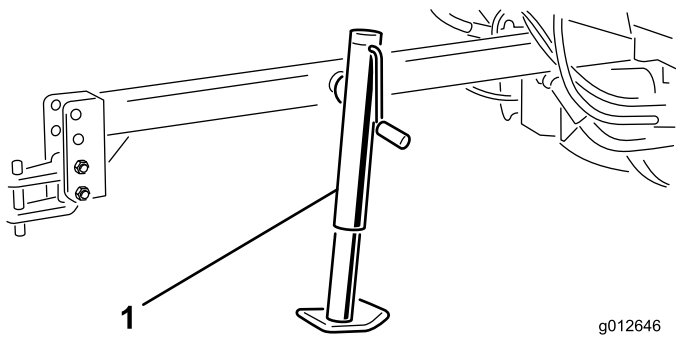

Figure 7

g012646
g012646

1. Jack

2. Align holes in jack with holes in the mounting tube and secure the jack with the clevis pin (Figure 7).
3. Position the jack as follows:
 - When you connect the machine to the traction unit—
 - A. Raise the jack.
 - B. Rotate it horizontal,
 - C. Secure the jack to the mounting tube with the clevis pin.
 - When you remove the machine from the traction unit—
 - A. Rotate the jack vertical.
 - B. Secure it to the mounting tube with the clevis pin.
 - C. Support the machine with the jack.

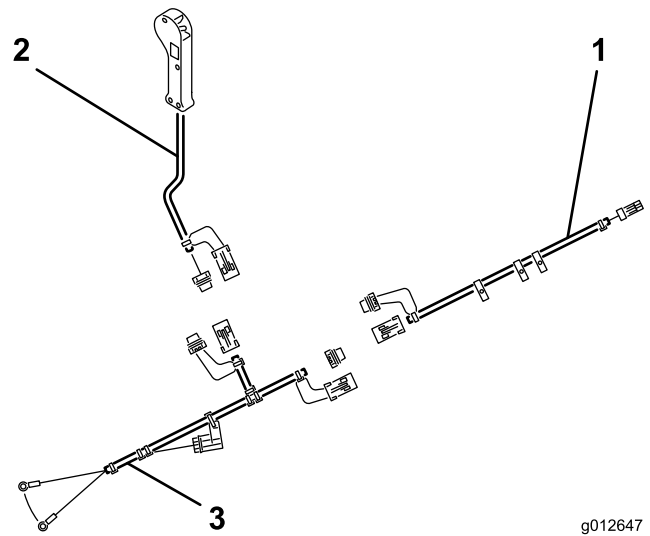

Figure 8

g012647
g012647

1. Topdresser harness
2. Controller harness
3. Tow-vehicle harness

2. Route the ring terminals of the tow-vehicle harness to battery of the traction unit.
 3. Assemble the ring terminal for the black wire of the tow-vehicle harness to the negative battery cable.
 4. Assemble the ring terminal for the red wire to the positive battery cable.
 5. Unplug loop back connectors from each of the harnesses and plug the topdresser harness, controller harness, tow vehicle harness and together.
- Note:** To prevent dirt or corrosion to harness connector pins, install the loop-back connectors into electrical connectors whenever vehicle harness is disconnected from the topdresser harness.
6. Route topdresser harness along tongue and secure it to tongue with cable ties.
 7. Plug controller harness connector into topdresser wire harness connector.
 8. Route to controller harness to the operator's position in the traction unit and secure the harness along frame rail with cable ties.

Note: Wire harnesses have removable connectors that allow you to permanently assemble the tow vehicle harness to the traction unit and the topdresser harness to the machine.

6

Installing the Wire Harness

Parts needed for this procedure:

1	Wire harness assembly (topdresser harness, controller harness, and tow-vehicle harness)
---	---

Procedure

1. Plug the connector of the topdresser wire harness into electrical connector on solenoid valve of the machine (Figure 8).

7

Mounting the Skids

Parts needed for this procedure:

4	Skid
8	Carriage bolt
8	Flat washer
8	Locknut

Procedure

1. Position skid as shown in [Figure 9](#).

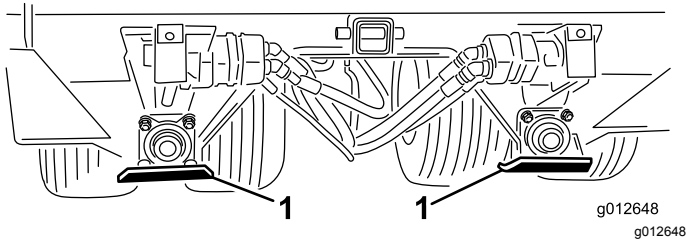

Figure 9

1. Skid (4)
2. Mount a skid to the mounting bracket with 2 carriage bolts, 2 flat washers and 2 locknuts.
3. Repeat steps 1 and 2 for the skids at the 3 other mounting brackets.

Product Overview

Controls

Gate Metering Control

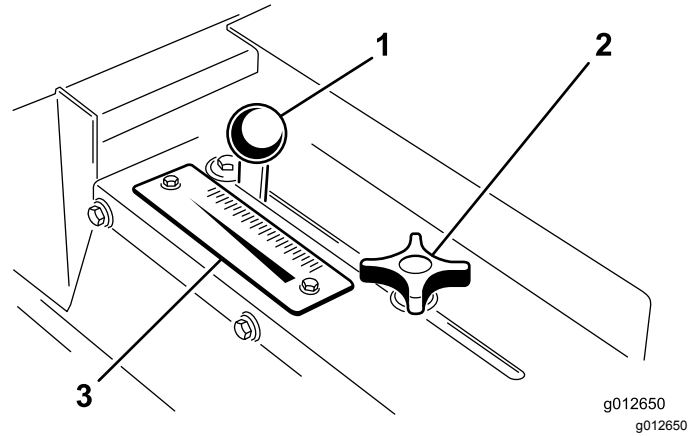

Figure 10

1. Adjusting handle
2. Gate-lock knob
3. Rate scale

The gate-lock knob and adjusting handle are located at the left rear side of machine, and are used to adjust and lock the gate into the desired open height position ([Figure 10](#)).

1. Loosen the adjusting gate-lock knob enough to allow gate and knob to slide freely in slot.
2. Move the adjusting handle to set the gate into the desired position, and tighten the gate-lock knob secure the gate.

Hand Control Switch

Press hand control switch to start or stop the flow of material from topdresser (Figure 11).

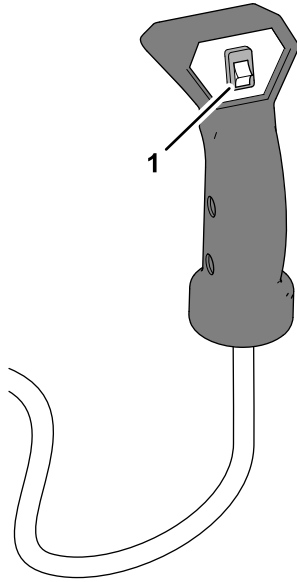

Figure 11

g269331

1. Hand control switch

Specifications

Length	With the tongue	254 cm (100 inches)
	Without the tongue	153.7 cm (60.5 inches)
Width		185 cm (73 inches)
Height		107.9 cm (42.5 inches)
Net weight		660 kg (1,455 lb)
Hopper volume		0.7 m ³ (25 ft ³)
Maximum material load		930 kg (2050 lb)
Maximum tow speed	Empty	24 kph (15 mph)
	Fully loaded	13 kph (8 mph)

Required Attachments

Topdresser Hydraulic Brake Kit	Part No. 106-9680
--------------------------------	-------------------

Optional Accessories

Tongue Jack (CE)	Part No. 106-9699
Mobil EAL 224 H Biodegradable hydraulic fluid (5 US gallon container)	Part No. 100-7674
Oil Filter	Part No. 86-3010
Extra Vehicle Harness	Part No. 99-0198

Recommended Accessories

Hand Throttle Kit	Model No. 07420
-------------------	-----------------

Attachments/Accessories

A selection of Toro approved attachments and accessories is available for use with the machine to enhance and expand its capabilities. Contact your Authorized Service Dealer or authorized Toro distributor or go to www.Toro.com for a list of all approved attachments and accessories.

To ensure optimum performance and continued safety certification of the machine, use only genuine Toro replacement parts and accessories. Replacement parts and accessories made by other manufacturers could be dangerous, and such use could void the product warranty.

Operation

Before Operation

Before Operation Safety

- The machine has different balance, weight, and handling characteristics compared to some other types of towed equipment. Read and understand the contents of this *Operator's Manual* before operating the machine. Become familiar with all controls and know how to stop quickly.
- Never allow children to operate the machine. Do not allow adults to operate the machine without proper instructions. Only trained and authorized persons should operate this machine.
- Keep all shields and safety devices in place. If a shield, safety device or decal is illegible or missing, repair or replace it before operating the machine.
- The machine is designed only for off-road use. The maximum recommended speed is 24 km/h (15 mph) without a load and 13 km/h (8 mph) with a full load.
- Tighten any loose nuts, bolts, and screws to ensure that the machine is in safe operating condition. Ensure that the machine tongue mounting pins, hitch pins, and tongue jack are in place and secure.
- Do not modify this equipment in any manner.
- The tongue is the area on the machine where the hitch connects to the tow vehicle. The weight of the tongue affects the stability of the machine.
 - A negative or positive tongue weight can cause injury when connecting or disconnecting the machine to the tow vehicle. When installed, ensure that the optional jack stand is properly engaged.
 - When the weight of the tongue is forced up into the hitch of the tow vehicle, this produces a negative tongue weight.
 - When the weight of the tongue is forced down onto the hitch of the tow vehicle, this produces a positive tongue weight.
- Never attach the machine to or remove the machine from the traction unit if there is material in the hopper. The tongue may flip up, causing injury.

Checking the Machine Before Operations

Perform the following checks daily:

- [Checking the Hydraulic Fluid Level \(page 28\)](#)
- [Checking the Tire Air Pressure \(page 21\)](#)
- [Checking the Hydraulic Lines and Hoses \(page 29\)](#)

During Operation

During Operation Safety

- The owner/operator can prevent and is responsible for accidents that may cause personal injury or property damage.
- Do not operate the machine when tired, ill, or under the influence of alcohol or drugs.
- Use your full attention while operating the machine. Do not engage in any activity that causes distractions; otherwise, injury or property damage may occur.
- Wear appropriate clothing, including eye protection; long pants; substantial, slip-resistant footwear; and hearing protection. Tie back long hair and do not wear loose clothing or loose jewelry.
- Never carry passengers on the machine and keep bystanders and pets away from the machine during operation.
- Keep your hands and feet out of hopper while the machine is operating or engine is running on the tow vehicle.
- Remain seated whenever the tow vehicle is in motion.
- Using the machine demands attention. Failing to operate tow vehicle safely may result in an accident, tip-over of the tow vehicle, and serious injury or death. Drive carefully, and to prevent tipping or loss of control, do the following:
 - Use extreme caution, reduce the speed, and maintain a safe distance around sand traps, ditches, water hazards, ramps, unfamiliar areas, or other hazards.
 - Reduce the speed of a loaded machine when negotiating terrain undulations to avoid causing the machine to become unstable.
 - Watch for holes or other hidden hazards.
 - Use caution when operating on a slope. Travel straight up and down slopes. Reduce speed when making sharp turns or when turning on hillsides. Avoid turning on hillsides whenever possible.

- Use extra caution when operating on wet surfaces, at higher speeds or with a full load. Stopping time increases with a full load. Shift into a lower gear before starting up or down a hill.
 - Avoid sudden stops and starts. Do not go from reverse to forward or forward to reverse without coming to a complete stop.
 - Do not attempt sharp turns or abrupt maneuvers or other unsafe driving actions that may cause a loss of control.
 - Be aware of your surroundings when turning or backing up the machine. Ensure that the area is clear and keep all bystanders at a safe distance. Proceed slowly.
 - Watch out for traffic when near or crossing roads. Always yield the right of way to pedestrians and other vehicles. Obey all traffic rules and check for local regulations on the operation of the machine on or near highways.
 - Always watch out for and avoid low overhangs such as tree limbs, door jambs, overhead walkways, etc. Ensure that there is enough room over head to easily clear the tow vehicle and your head.
 - Do not operate the machine when there is the risk of lightning.
 - If you are ever unsure about safe operation, stop working and ask your supervisor.
 - Do not leave the machine unattended while it is running.
- Ensure that the machine is connected to the tow vehicle before loading.
 - Do not carry loads that exceed the load limits of the machine or the tow vehicle.
 - The stability of loads can vary—for example, high loads have a higher center of gravity. Reduce the maximum load limits to ensure better stability, if necessary.
 - To avoid causing the machine to tip over, do the following:
 - Carefully monitor the height and weight of the load. Higher and heavier loads can increase the risk of tipping.
 - Distribute the load evenly, from front to back and side to side.
 - Be careful when turning and avoid unsafe maneuvers.
 - Always ensure that the machine is connected to the tow vehicle before loading.
 - Do not put large or heavy objects into the hopper. This could damage the belt and rollers. Also ensure that the load has a uniform texture. Small rocks in the sand can become projectiles.
- Do not stand behind the machine when unloading or spreading.
 - Unload the machine or disconnect it from the tow vehicle while on a level surface.
 - Ensure that the machine is connected to the tow vehicle before unloading.
 - Shut off the machine when approaching people, vehicles, vehicle crossings, or pedestrian crossings.
 - When equipped, hydraulic trailer brakes may overheat the fluid in the hydraulic circuit if the brakes remain activated continuously. Always use a lower speed gear selection when descending long hills. Activate the brakes intermittently to allow for cooling cycles for both the vehicle and the topdresser.

Slope Safety

- Slopes are a major factor related to loss of control and rollover accidents, which can result in severe injury or death. You are responsible for safe slope operation. Operating the machine on any slope requires extra caution. Before using the machine on a slope, do the following:
 - Evaluate the site conditions to determine if the slope is safe for machine operation, including surveying the site. Always use common sense and good judgment when performing this survey.
 - Review the slope instructions listed below for operating the machine on slopes and to determine whether you can operate the machine in the conditions on that day and at that site. Changes in the terrain can result in a change in slope operation for the machine.
 - Use extreme caution when traveling on hills, especially when turning.
 - Traveling across hills with the machine could result in a tip-over, or a loss of traction for the traction unit or the machine.
 - Always travel straight up and down hills—do not travel sideways or diagonally. When traveling down a hill, do not exceed the speed at which you can travel up the same hill. Stopping distance increases when traveling down hills.
 - Reduce the weight of the load when traveling on steep hills and avoid piling the load high.
- Identify hazards at the base of the slope. Use extreme caution when operating the machine near drop-offs, ditches, embankments, water, or other hazards. The machine could suddenly roll over if a

wheel goes over the edge or the edge collapses. Keep a safe distance (twice the width of the machine) between the machine and any hazard.

- Remove or mark obstacles such as ditches, holes, ruts, bumps, rocks, or other hidden hazards. Tall grass can hide obstacles. Uneven terrain could overturn the machine.
- Avoid starting, stopping, or turning the machine on slopes. Avoid making sudden changes in speed or direction; turn slowly and gradually.
- Do not operate a machine under any conditions where traction, steering, or stability is in question. Be aware that operating the machine on wet grass, across slopes, or downhill may cause the machine to lose traction. Loss of traction to the drive wheels may result in sliding and a loss of braking and steering. The machine can slide even if the drive wheels are stopped.
- Be aware that operating the machine on wet grass, across slopes, or downhill may cause the machine to lose traction. Loss of traction to the drive wheels may result in sliding and a loss of braking and steering.
- Always keep the traction unit in gear when going down slopes. Do not coast downhill (applicable only to gear-drive units).

Operating the Machine

Important: Always read and understand the operator's manual for the traction before using the machine.

1. Start the traction unit; refer to the traction unit operator's manual.
2. Before adding material into hopper, drive the traction unit and topdresser to check that the belt moves smoothly.

Note: When operating the machine in cold weather; refer to [Preparing for Cold Weather Operation \(page 16\)](#).

3. Load sand or other topdressing material into the hopper; refer to [Loading the Hopper \(page 15\)](#).

Important: Overloading the hopper may result in tire side-wall deflection and marking the green on first few passes. Check the air pressure of all tires; refer to [Checking the Tire Air Pressure \(page 21\)](#)

4. Transport the machine to the area to be top-dressed.
5. Adjust the metering gate to the desired application rate, and lock the gate into position with the gate-lock knob.

When applying sand, refer to the [Sand Application Rate \(page 15\)](#) for additional information.

6. For best results, shift traction unit to the Low range position. Drive the traction unit forward at the desired ground speed.
7. Press hand control switch to start or stop the flow of material from topdresser.

Loading the Hopper

- The maximum material volume of the hopper is 0.7 m³ (25 ft³).
- Generally, dry sand weighs 1602 kg/m³ (100 lb/ft³) and wet sand weighs 1922 to 2082 kg/m³ (120 to 130 lb/ft³). You will overload the machine if more than 930 kg (2050 lb) of sand is loaded into the hopper.
- Position the weight of the load evenly from front to rear and evenly from side to side.
- Transporting or topdressing with a full load can cause shifting of the sand. This shifting happens most often while turning, going up or down hills, suddenly changing speeds or while driving over rough surfaces. Shifting loads can lead to tip-overs. Use caution when transporting or topdressing with a full load.
- Heavy loads increase stopping distance and reduce your ability to turn quickly without tipping over.

Sand Application Rate

The rate of sand applied depends on the gate setting. Sand varies in moisture and coarseness (size of grain), which effects the application rate. These factors must be taken into consideration when deciding the amount of sand required for the application. Test a small area to decide the correct amount. To increase application rate open gate to a higher scale mark.

The machine is ground driven which assures consistent application, from green to green, when towing the machine at 3.2 to 13 kph (2 to 8 mph).

Sand Precautions

The machine is equipped with a flexible gate edge ([Figure 12](#)) and a spring release mechanism to reduce the chance of sand chunks or rocks getting lodged during operation. To ensure long belt life, sift or check the sand for rocks with sharp edges that may damage conveyor belt.

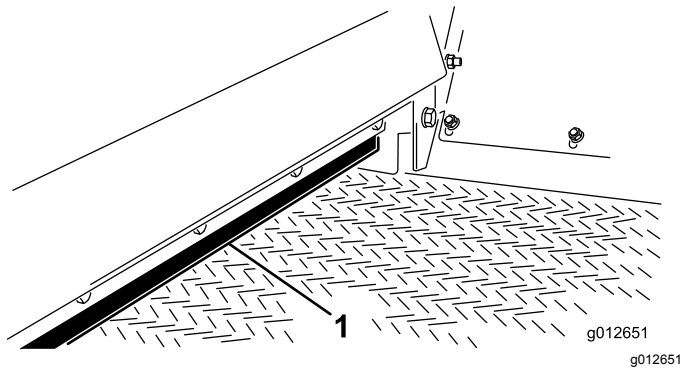

Figure 12

1. Gate edge

Preparing for Cold Weather Operation

Although limited by the traction of the drive tires, you may use the machine in cold weather. With certain limitations, you may use the machine to apply a salt/sand mixture on pavement for ice control. The PVC conveyor belt material becomes very stiff in cold weather and requires more power to operate belt. The life of the belt is reduced by approximately 50% when operated below temperatures of 40 degrees F. (5 degrees C.).

Important: Do not operate the topdresser during temperatures of -7° C (20° F) or lower.

1. Increase the belt tension by adjusting spring compression to 4 inches (101 mm); refer to [Tensioning the Conveyor-Belt Chain \(page 22\)](#).
2. Run belt before loading the hopper with material to assure that belt system moves freely.

Important: If belt/drive roller slip, damage to belt or roller may occur.

Important: Before operating the machine during warm weather, adjust the belt tension to 4-7/16 inches (112 mm) spring compression.

Operating Tips

- The topdresser material application system is ground driven, so you need to tow the machine to check the operation of the belt and brush.
- Top dressing works best when towing the machine 3.2 to 13 kph (2 to 8 mph). The machine compensates for variations in travel speed, and will give consistent distribution, even if your travel speed changes during a pass across the green. The operator/superintendent should make the gate setting selection (variable in 1/8 increments to 13) and make a first pass to determine if application rate is acceptable.

When applying sand, refer to the [Sand Application Rate \(page 15\)](#) for additional information.

- After the machine is moving, operation begins when the hand control switch is activated. It may require practice to start and stop the flow of material at the desired area of a green or tee box.
- Before loading hopper, make sure that the topdresser is properly connected to tow vehicle, to prevent flip-up or any unintended tongue movement. Do not disconnect the topdresser from tow vehicle while material is in the hopper. The tongue may flip up causing injury.
- The topdresser is wider than most traction units. Before traveling through a narrow area such as a gate, door entry, etc., check width of the opening before proceeding, and allow clearance to turn the machine.
- The top dresser adds extra towing weight to the traction unit. Drive it safely.
 - Do not drive on the highway or a public road.
 - Always slow the traction unit when approaching and while making a turn.
 - Always slow the traction unit when driving in an unfamiliar area or over rough terrain.
 - Always slow the traction unit when changing direction of travel or when preparing to stop.
 - When turning or driving the machine on a slope, always slow the traction unit, then turn the machine to prevent losing control and possible rollover.
 - Do not make sudden or sharp turns. Do not suddenly change direction of travel on an incline, ramp, grade, slope, or similar surface.
 - Always adjust the traction unit speed to allow for existing ground conditions such as wet or slick surfaces, loose sand or gravel, low-visibility conditions such as dim or bright lighting, fog, mist, or rain.
 - Be especially careful when driving a heavily loaded vehicle down an incline or slope. Drive the vehicle up and down the face of the slopes,

inclines, or grades whenever possible. Do not drive across the face of a slope if possible. There is a risk of overturning the machine, which can result in serious injury or death.

⚠ WARNING

Tipping or rolling the tow vehicle on a hill will cause serious injury.

- **If engine stalls or you lose headway on a hill, never attempt to turn tow vehicle around.**
 - **Always back straight down a hill in reverse gear.**
 - **Do not back down in neutral or with the clutch depressed, using only the brakes.**
 - **Do not add sideboards or panels to the top of the hopper to increase the load capacity. The additional weight will cause tipping or rolling of the tow vehicle and lead to serious injury.**
 - **Do not drive across a hill, always drive straight up or down. Avoid turning on a hill. Do not "drop the clutch" or slam on the brakes. Sudden speed change can initiate a tip-over.**
- In tight areas, where a straight line pass across a green is not possible, you can back the machine into the area without harm and begin topdressing when pulling forward.
 - Before backing up, look to the rear and assure that no one is behind. Back up slowly and watch the machine closely.
 - Use extreme caution and slow speed when backing up the machine and traction unit.
 - The maximum recommended towing speed of the machine is 24 kph (15 mph) when empty and 13 kph (8 mph) when loaded. As with any trailer, always use caution when turning or backing up. Be aware of persons or objects near the topdresser path of travel.
 - Watch out for traffic when near or crossing roads. Always yield the right of way to pedestrians and other vehicles.
 - If the top dresser begins to vibrate abnormally, stop the traction unit, engage the parking brake, shut off engine, remove the key, and wait for all moving parts to stop. Repair any wear or damage before towing the machine.
 - If you hear cavitation noise while transporting the machine across the golf course, slow down, return to maintenance, and investigate the cause. Do not exceed the 13 kph (8 mph) tow speed. This machine was not designed for travel on highways. Towing the machine faster than 24 kph (15 mph) will damage the internal hydraulic components.
- Before servicing or making any adjustments to the top dresser:
 - Stop the traction unit and set the parking brake.
 - Shut off the engine, remove key, and wait for all moving parts to stop before leaving the operator's seat.
 - Keep all hardware tight secure. Install all serviceable parts removed during maintenance or adjustments.
 - When loading the top-dressing material into the hopper, be careful that the loader or skid steer bucket does not strike and damage the hopper. Although the hopper is designed wide enough to clear most buckets, it is not strong enough to take a contact and may deform the sheet metal.
 - Material application is always best with dry material, but wet sand can be spread with the machine. You may need to adjust the gate setting, but the material should flow out and spread relatively smooth and consistent. If the belt slips, check the belt tension and clean-out provisions.
 - Top-dressing material can vary in grain size as well as moisture content. It can also contain impurities that may either damage greens mowers or plant tissue. Always control the source of top-dressing material, and use care when handling and loading it.
 - A sight window is provided at the right front hopper panel to monitor remaining material while topdressing. It is a good practice to check the sight window and for hopper volume before beginning application to assure that you do not run out of top-dressing material in the middle of the pass.
 - The special oscillating drive axles on the machine are designed to continuously power the hydraulic system while the machine travels over surface irregularities of a green or tee. Always approach a severe berm slowly to avoid sudden impact of the axles with the turf, and to reduce the potential of leaving tire marks on the approach to the green.

⚠ WARNING

Rotating parts of the machine can grab or pinch you.

Stay clear of brush and conveyor belt while unit is running.

- Safe operation begins before taking the top dresser out for a day's work. Read and understand the operating instructions in the Toro Workman or other traction unit operator's manual before using the topdresser.

After Operation

After Operation Safety

- Park the machine on a firm, level surface; engage the parking brake; shut off the engine; remove the key; and wait for all movement to stop before leaving the machine.
- Avoid soft ground because the jack leg could sink and cause the machine to tip over.
- Do not disconnect the machine from the tow vehicle on hills, or without engaging the optional jack.
- When disconnecting the machine, always chock the wheels to prevent movement.
- Keep all parts of the machine in good working condition and all hardware tightened.
- Replace all worn or damaged decals.

Maintenance

Maintenance Safety

- Before servicing or adjusting the machine, stop the machine, shut off the engine, engage the parking brake, remove the key, and wait for all moving parts to stop.
- Perform only those maintenance instructions described in this manual. If major repairs are ever needed or assistance is desired, contact an authorized Toro distributor.
- Ensure that the machine is in safe operating condition by keeping nuts, bolts, and screws tight.
- If possible, do not perform maintenance while the engine is running. Keep away from moving parts.
- Do not check or adjust the chain tension when the tow vehicle engine is running.
- Carefully release pressure from components with stored energy.
- Support the machine with blocks or jack stands when working beneath it.
- After maintaining or adjusting the machine, ensure that all guards are installed.

Recommended Maintenance Schedule(s)

Maintenance Service Interval	Maintenance Procedure
After the first hour	<ul style="list-style-type: none"> • Torque the wheel bolts.
After the first 10 hours	<ul style="list-style-type: none"> • Torque the wheel bolts.
Before each use or daily	<ul style="list-style-type: none"> • Check the tire air pressure. • Check the hydraulic fluid level. • Check the hydraulic lines and hoses
Every 40 hours	<ul style="list-style-type: none"> • Check the brush position and wear.
Every 200 hours	<ul style="list-style-type: none"> • Lubricate all the grease fittings • Torque the wheel bolts. • Change the hydraulic fluid. • Replace the hydraulic filter.

Pre-Maintenance Procedures

Preparing for Maintenance

1. Shut off the hand-control switch for the topdresser.
2. Move the machine to a level surface.
3. Set the parking brake of the traction unit, shut off the engine, remove the key, and wait for all moving parts to stop before leaving the operator's seat.

Raising the Machine

1. Empty the hopper.
2. Perform the steps in [Preparing for Maintenance \(page 19\)](#).
3. Use the skids as the jacking points.

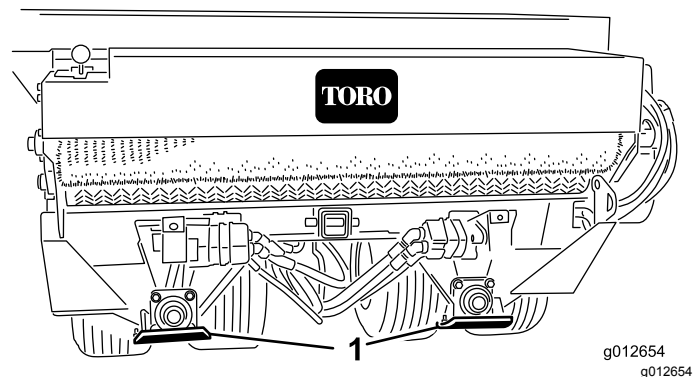

Figure 13

1. Skid (4)
4. Support the machine with jack stands.

- When working on the wheels, pivot them up or down to expose wheel bolts.

Important: If you remove the wheels and installed them, torque wheel bolts as specified in [Torqueing the Wheel Bolts \(page 21\)](#). Incorrect bolt torque could result in failure or loss of the wheel.

Lubrication

Grease Specification

No. 2 Lithium based grease

Greasing the Bearings and Bushings

Service Interval: Every 200 hours/Yearly (whichever comes first)

- Perform the steps in [Preparing for Maintenance \(page 19\)](#).
- Lubricant each of the grease fitting described in the grease-fitting table with the specified grease.

Grease-Fitting Table

Location	Quantity
Roller shaft bearing (Figure 14)	4
Brush shaft bearing (Figure 14)	1
Pivot bearing (Figure 15)	4
Wheel bearing (Figure 15)	4

Important: Lubricate the bearings to maintain a slight leakage between bearings and housings. Too much grease can cause overheating or damage to seals.

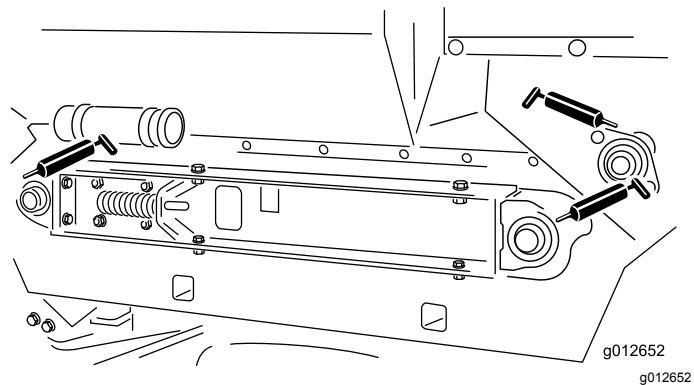

Figure 14

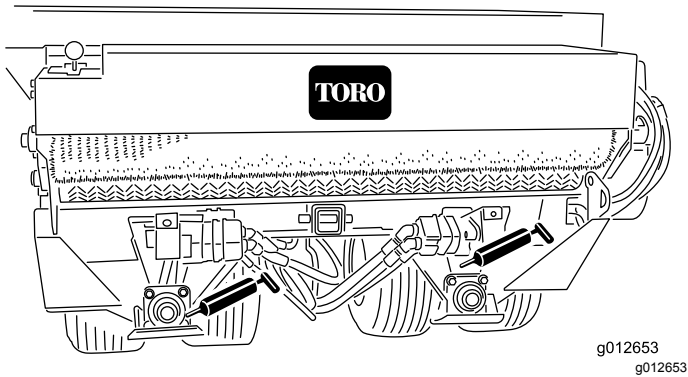

Figure 15

Note: We do not recommend lubricating the drive chains unless they become stiff from rust. If the chain rusts, lightly lubricate it with a dry-type lubricant. This reduces the likelihood of sand build-up or other top-dressing material adhering to the chain.

Drive System Maintenance

Checking the Tire Air Pressure

Service Interval: Before each use or daily

1. Perform the steps in [Preparing for Maintenance \(page 19\)](#).
2. Check the tire air pressure.
You should measure 138 to 207 kPa (20 to 30 psi) air pressure.
3. If the tire air pressure is too low or too high, add air to or remove air from the tires until you measure 138 to 207 kPa (20 to 30 psi).

Torquing the Wheel Bolts

Service Interval: After the first hour

After the first 10 hours

Every 200 hours

Important: Failure to maintain proper torque could result in failure or loss of wheel.

1. Perform the steps in [Preparing for Maintenance \(page 19\)](#).
2. Torque 20 wheel bolts to 109 to 122 N·m(80-90 ft-lb).

Tensioning the Wheel-Drive Chain

1. Perform the steps in [Preparing for Maintenance \(page 19\)](#).
2. Loosen carriage bolts and nuts that secure the hydraulic motor/pump to axle cradle ([Figure 16](#)).

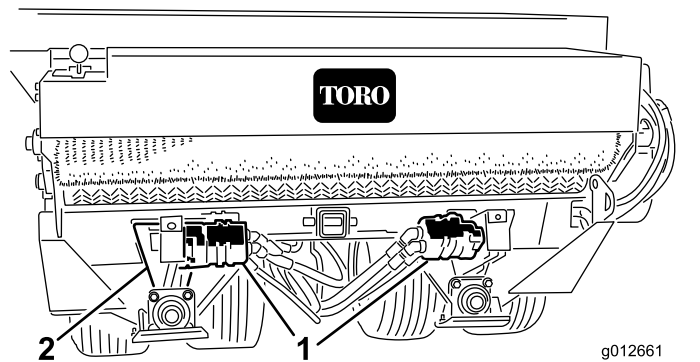

Figure 16

1. Hydraulic motor
2. Axle cradle cut-out

3. Rotate motor sprocket assembly (Figure 16) until the wheel-drive chain deflects 3.2 mm (1/8 inch).

Note: Access to chain is through cutout in lower side of axle cradle.

Important: Do not over tension the chain or it will wear prematurely. Do not under-tension the chain or it will cause sprocket wear.

4. Tighten mounting bolts.

Note: We do not recommend lubricating the drive chains unless they become stiff from rust. If the chain rusts, lightly lubricate it with a dry-type lubricant. This reduces the likelihood of sand build-up or other top-dressing material adhering to the chain.

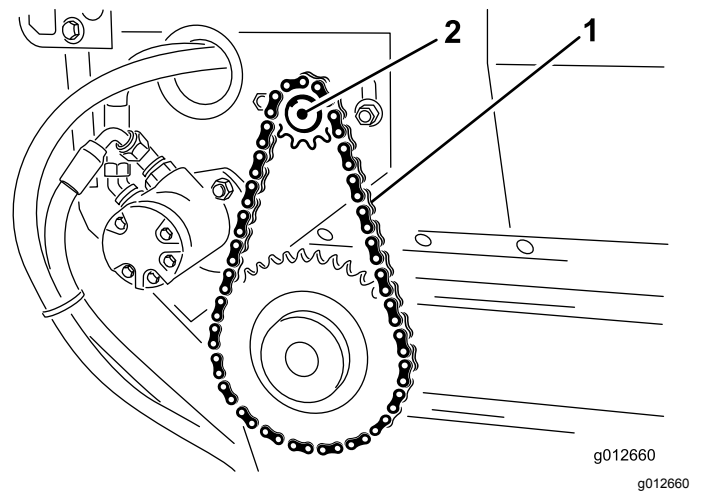

Figure 18

1. Conveyor-belt chain
2. Motor and sprocket assembly

Tensioning the Conveyor-Belt Chain

1. Perform the steps in [Preparing for Maintenance](#) (page 19).
2. Remove the chain cover (Figure 17).

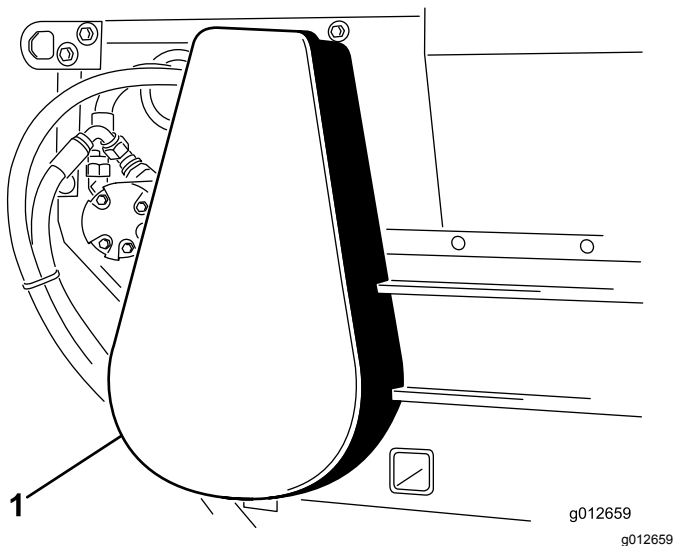

Figure 17

1. Chain cover

3. Loosen bolts and nuts that secure the motor and sprocket assembly to the main frame (Figure 18).
4. Rotate motor and sprocket assembly (Figure 18) in mounting slots until the conveyor-belt chain deflects 3.2 mm (1/8 inch).

Important: Do not over tension the chain or it will wear prematurely. Do not under-tension the chain or it will cause sprocket wear.

5. Tighten mounting bolts (Figure 18).
6. Install chain cover (Figure 17).

Belt Maintenance

Tensioning the Conveyor Belt

When conveyor belt is adjusted properly, the compressed length of each compression spring should be 4-7/16 inches (112 mm). Adjust conveyor belt as follows:

1. Empty the hopper.
2. Perform the steps in [Preparing for Maintenance](#) (page 19).
3. Loosen rear jam nut ([Figure 19](#)).

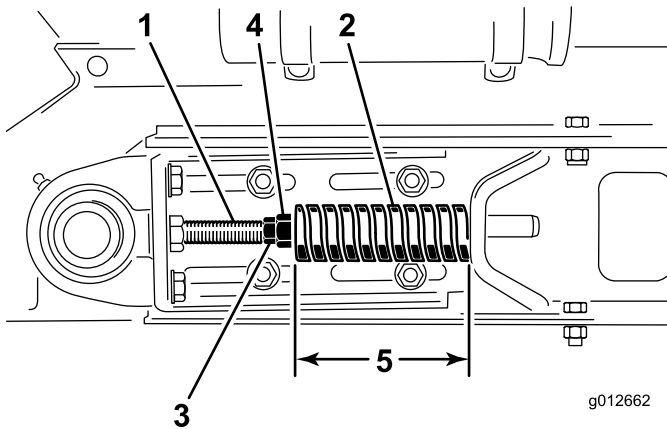

Figure 19

- | | |
|-----------------------|---|
| 1. Tension rod | 4. Jam nut (rear) |
| 2. Compression spring | 5. Spring compression
4-7/16 inches (112 mm) |
| 3. Jam nut (forward) | |

4. Adjust forward jam nut to compression spring to 4-7/16 inches (112 mm).
5. Tighten jam rear nut.
6. Repeat steps 3 through 5 at the other side of the machine
7. Measure the distance between center points of the belt-roller shafts at each side of machine to ensure that the measurements are equal ([Figure 20](#)).

Equal distance measures approximately 895 mm (35-1/4 inches).

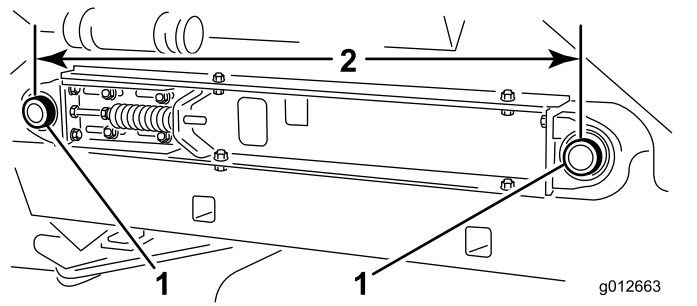

Figure 20

- | | |
|-----------------------|---------------------------|
| 1. Belt-roller shafts | 2. 35-1/4 inches (895 mm) |
|-----------------------|---------------------------|

Replacing the Conveyor Belt

Preparing to Machine

1. Empty the hopper.
2. Perform the steps in [Preparing for Maintenance](#) (page 19).
3. Inspect hopper seals and gate edge for wear or torn edges ([Figure 21](#)).

Replace worn or damaged components to ensure proper operation of new conveyor belt.

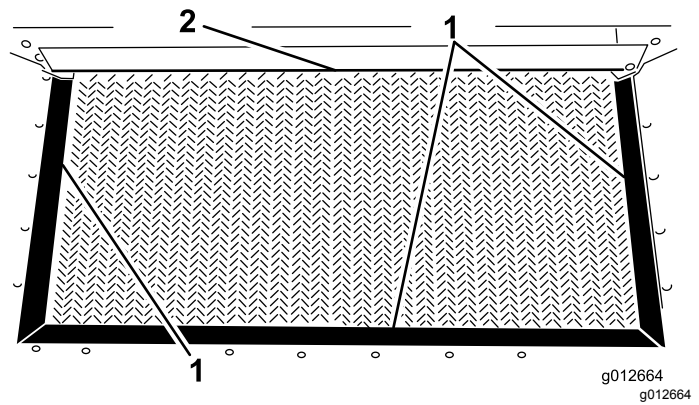

Figure 21

- | | |
|----------------|--------------|
| 1. Hopper seal | 2. Gate edge |
|----------------|--------------|

Removing the Conveyor Chain

1. Remove chain cover (Figure 22).

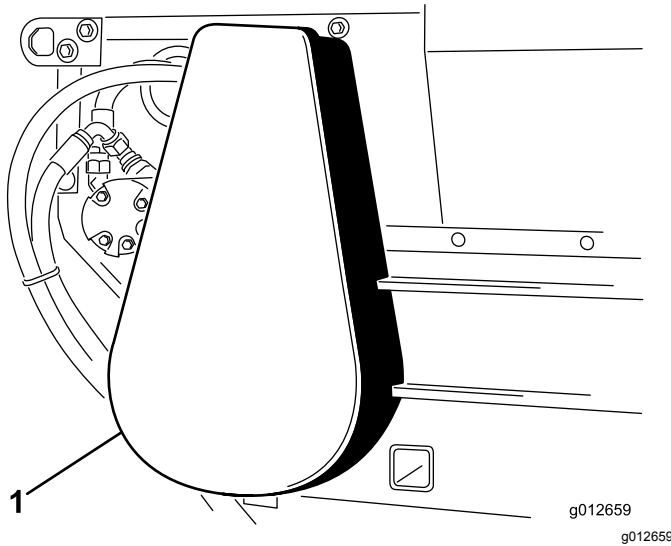

Figure 22

1. Chain cover

2. Remove master link from chain and remove chain from small sprocket (Figure 23).

If needed, loosen the motor-mount bolts to remove the master link.

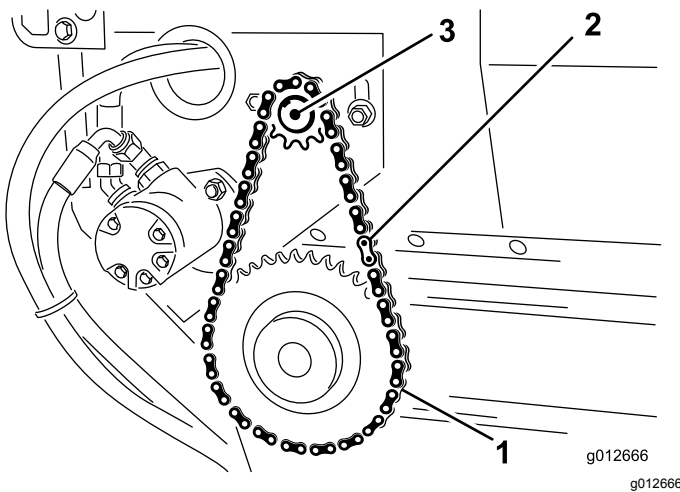

Figure 23

1. Drive chain
2. Master link
3. Motor

Disassembling the Slider Bed

1. Loosen forward and rear jam nuts on tension rod to release spring tension (Figure 24).

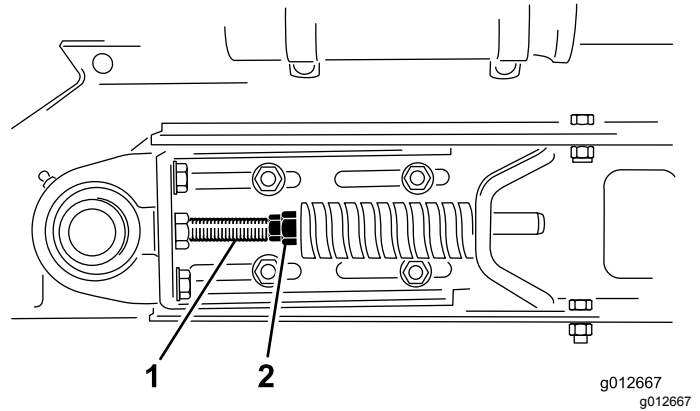

Figure 24

1. Tension rods
2. Jam nut

2. At each side of machine, remove 2 capscrews, 2 washers, and 2 locknuts that secure the hopper to slider-frame rails (Figure 25).

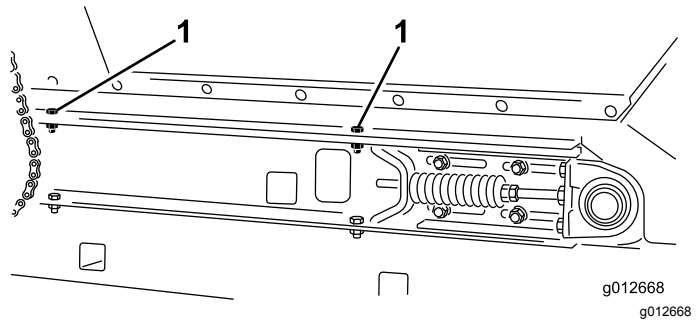

Figure 25
Right side shown

1. Capscrews (hopper mounting)

3. Pivot hopper rearward and lean it against wall, post, ladder, etc. (Figure 26)

Important: Do not allow hopper to rest against the rear of machine to avoid damaging the brush or the hydraulic couplers.

Make sure that the hopper is pivoted beyond center and/or secured to wall or post to prevent it from accidentally falling on work area (Figure 26).

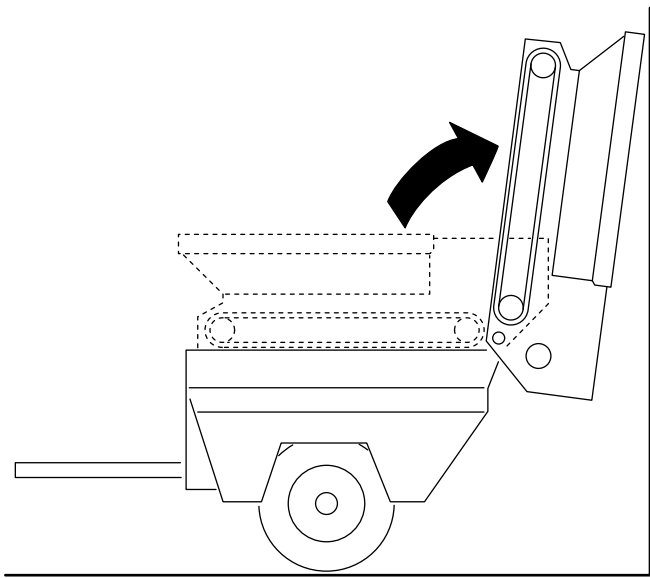

g012669
g012669

Figure 26

- At the right side of machine, loosen 2 capscrews that secure slider-frame rail to the right fender ([Figure 27](#)). Ensure that the capscrews are loose enough to allow slider bed tip.

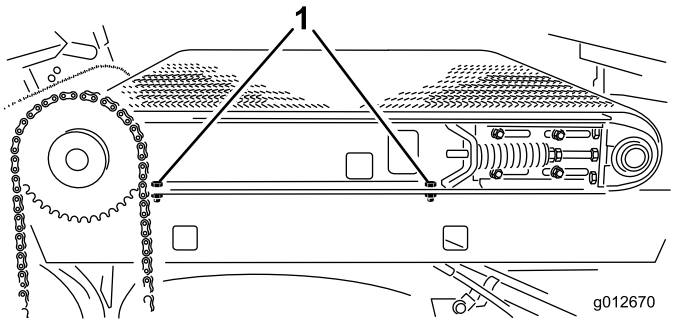

g012670
g012670

Figure 27

- Capscrews (slider-frame rail)

- At the left side of machine, remove 2 capscrews and 2 washers that secure slider-frame rail to the left fender ([Figure 28](#)).

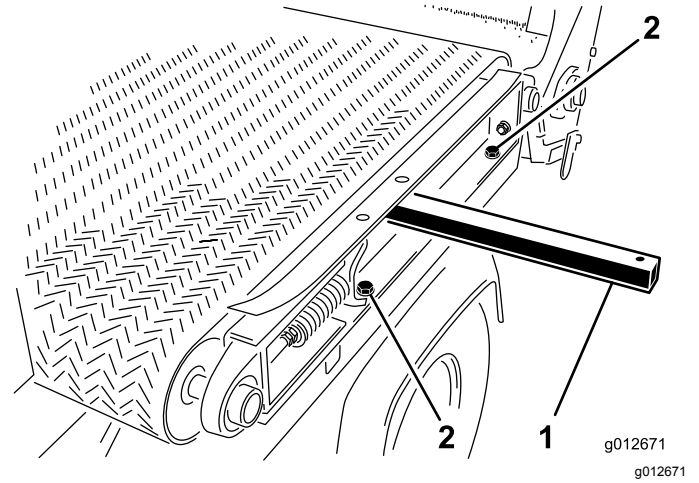

g012671
g012671

Figure 28

- Lifting rod
- Capscrews (slider-frame rail)

Removing the Belt

Cut belt and remove it from rollers.

Installing the Belt

- Insert a lift bar through the hole in left slider-frame rail and raise lift bar to tip frame rail slightly; refer to [Figure 28](#) in [Disassembling the Slider Bed](#) (page 24).
- Assemble the belt over the lift bar and rollers as far as possible.
- Insert a plastic belt tool between each roller and the belt.

Rotate rollers until each tool is positioned to the outside of each roller. Insert the tool past rib in the center of belt.

- Slide belt and belt tools further onto rollers until belt is centered on rollers.
- Remove belt tools.
- Align belt so that the belt rib fits into alignment grooves in each roller.

Assembling the Slider Bed

1. At the left side of machine, assemble the slider-frame rail to the left fender ([Figure 29](#)) with the 2 capscrews and 2 washers that you removed in [Disassembling the Slider Bed \(page 24\)](#), and tighten the capscrews.

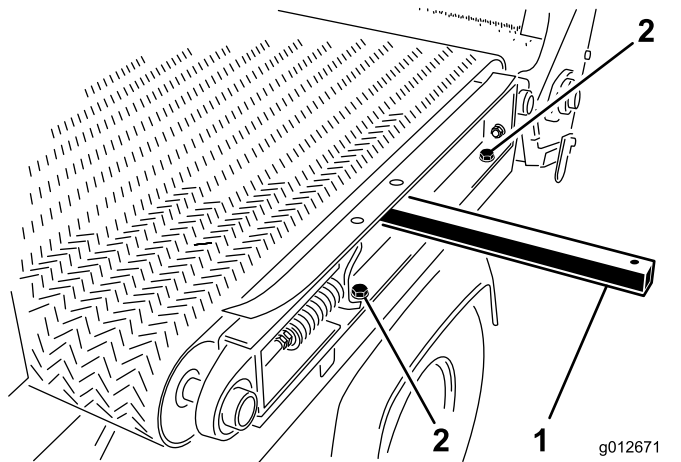

Figure 29

1. Lifting rod
2. Capscrews (slider-frame rail)

2. At the right side of machine, tighten 2 capscrews that secure slider-frame rail to the right fender ([Figure 30](#)).

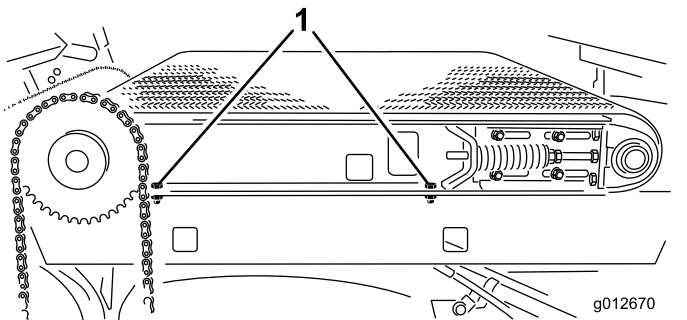

Figure 30

1. Capscrews (slider-frame rail)

3. Carefully rotate the hopper down onto the slider-frame rails; refer to [Figure 26 of Disassembling the Slider Bed \(page 24\)](#)
4. At each side of machine, secure the hopper to slider-frame rails ([Figure 31](#)) with the 2 capscrews, 2 washers, and 2 locknuts that you removed in [Disassembling the Slider Bed \(page 24\)](#).

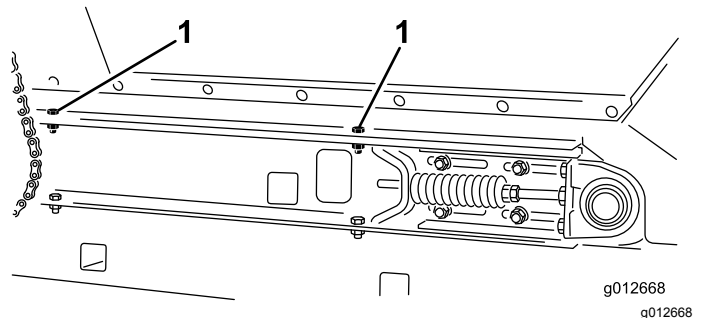

Figure 31
Right side shown

1. Capscrews (hopper mounting)

5. Tension the conveyer belt; refer to [Tensioning the Conveyer Belt \(page 23\)](#)

Installing the Conveyer Chain

1. Assemble the chain onto the small sprocket and secure the chain with the master link ([Figure 32](#)).

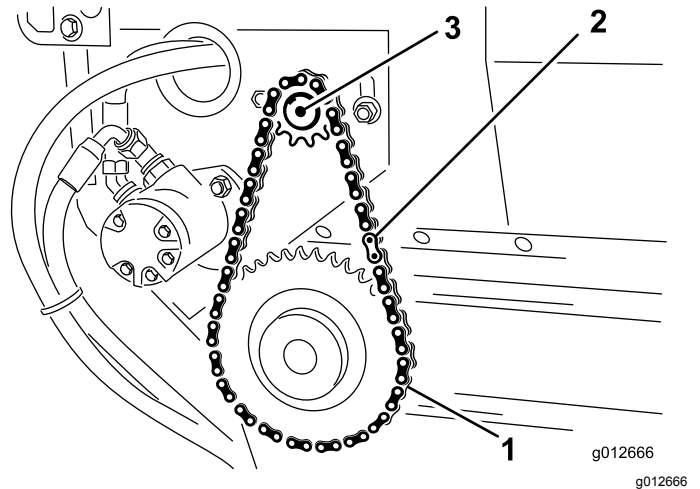

Figure 32

1. Drive chain
2. Master link
3. Motor

2. If you loosen the motor-mount bolts, tension the conveyer-belt chain, refer to [Tensioning the Conveyer-Belt Chain \(page 22\)](#)
3. Install the chain cover ([Figure 33](#)).

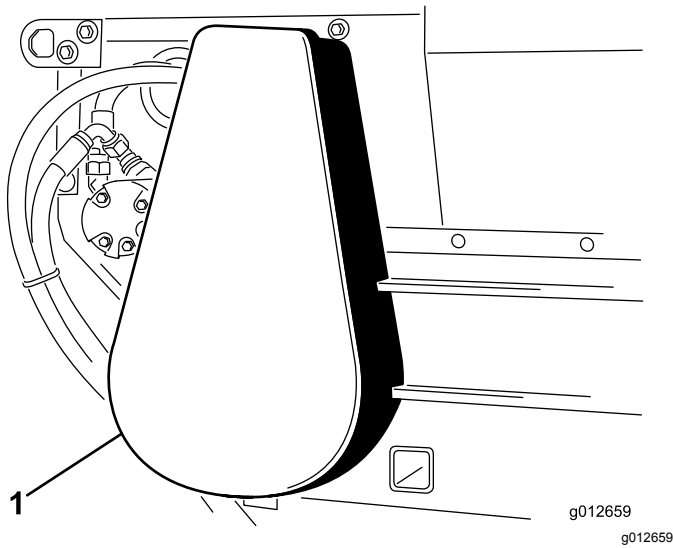

Figure 33

1. Chain cover

Hydraulic System Maintenance

Hydraulic System Safety

- Seek immediate medical attention if fluid is injected into skin. Injected fluid must be surgically removed within a few hours by a doctor.
- Ensure that all hydraulic-fluid hoses and lines are in good condition and all hydraulic connections and fittings are tight before applying pressure to the hydraulic system.
- Keep your body and hands away from pinhole leaks or nozzles that eject high-pressure hydraulic fluid.
- Use cardboard or paper to find hydraulic leaks.
- Safely relieve all pressure in the hydraulic system before performing any work on the hydraulic system.

Hydraulic Fluid Specification

The recommended replacement fluid is:

Toro Premium All Season Hydraulic Fluid:

Available in 19 L (5 US gallon) containers or 208 L (55 US gallon) drums—see the *Parts Catalog* or your Toro distributor for part numbers.

Alternative fluids: If the Toro fluid is not available, other fluids may be used provided that they meet all of the following material properties and industry specifications. Check with your oil supplier to identify a satisfactory product.

Note: Toro does not assume responsibility for damage caused by improper substitutions, so use only products from reputable manufacturers who stand behind their recommendation.

High Viscosity Index/Low Pour Point Antiwear Hydraulic Fluid, ISO VG 46 Multigrade

Material Properties:

Viscosity, ASTM D445	cSt @ 40°C (104°F) 44 to 48 cSt @ 100°C (212°F) 7.9 to 9.1
Viscosity index, ASTM D2270	140 or higher (high viscosity index indicates a multiweight fluid)
Pour point, ASTM D97	-36.7°C to -45°C (-34°F to -49°F)
FZG, fail stage	11 or better
Water content (new fluid)	500 ppm (maximum)

Industry Specifications:

Vickers I-286-S, Vickers M-2950-S, Denison HF-0, Vickers 35 VQ 25 (Eaton ATS373-C)

The proper hydraulic fluids must be specified for mobile machinery (as opposed to industrial plant usage), multiweight-type, with ZnDTP or ZDDP antiwear additive package (not an ashless-type fluid).

Important: Many hydraulic fluids are almost colorless, making it difficult to spot leaks. A red dye additive for the hydraulic system oil is available in 20 ml (2/3 fl oz) bottles. One bottle is sufficient for 15 to 22 L (4 to 6 US gallons) of hydraulic fluid. Order part 44-2500 from your authorized Toro distributor.

Synthetic, Biodegradable Hydraulic Fluid: Available in 19 L (5 US gallon) containers or 208 L (55 US gallon) drums—see the *Parts Catalog* or your Toro distributor for part numbers.

This high-quality, synthetic, biodegradable fluid has been tested and found compatible for this Toro model. Other brands of synthetic fluid may have seal compatibility problems and Toro cannot assume responsibility for unauthorized substitutions.

Note: This synthetic fluid is not compatible with the Toro Biodegradable Fluid previously sold. See your Toro Distributor for more information.

Alternative fluids:

- Mobil EAL EnviroSyn H 46 (US)
- Mobil EAL Hydraulic Oil 46 (international)

Checking the Hydraulic Fluid Level

Service Interval: Before each use or daily

1. Perform the steps in [Preparing for Maintenance \(page 19\)](#)
2. Clean area around filler neck and cap of hydraulic tank, and remove the cap ([Figure 34](#)).

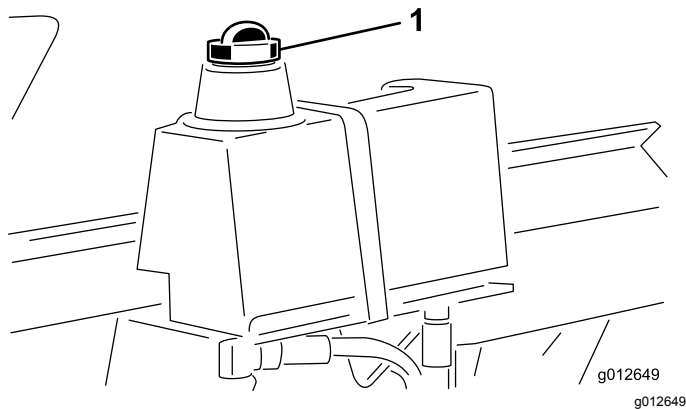

Figure 34

1. Hydraulic tank cap

3. Check fluid level. Fluid level should be 1/2 way up the screen in filler neck.

4. If level is low, add the specified fluid to raise level.

Changing the Hydraulic Fluid

Service Interval: Every 200 hours/Yearly (whichever comes first)—Change the hydraulic fluid. If fluid becomes contaminated, contact your authorized Toro distributor because the complete system must be drained. Contaminated fluid looks milky or black when compared to clean oil.

Reservoir fluid capacity: approximately 9.5 L (2.5 US gallon)

1. Perform the steps in [Preparing for Maintenance \(page 19\)](#).
2. Align a drain pan with a 9.5 L (2.5 US gallon) capacity under the hydraulic reservoir.
3. Remove the fitting from bottom of hydraulic reservoir and allow the reservoir to drain completely ([Figure 35](#)).

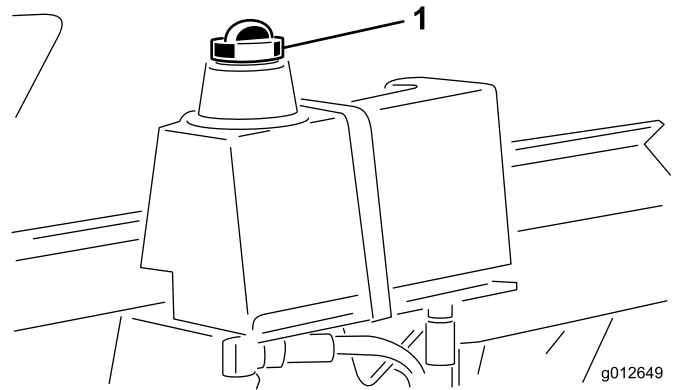

Figure 35

1. Hydraulic reservoir cap

4. Install and tighten hydraulic-reservoir fitting.
5. Clean area around filler neck and cap of hydraulic tank, and remove the cap ([Figure 35](#)).
6. Add approximately 9.5 L (2.5 US gallon) of the specified hydraulic fluid; refer to [Hydraulic Fluid Specification \(page 27\)](#).

Important: Use only hydraulic fluids specified. Other fluids could cause damage to components of the hydraulic system.

7. Check level of fluid and add enough to the fluid level stated in [Checking the Hydraulic Fluid Level \(page 28\)](#).

Important: Do not overfill the reservoir with hydraulic fluid.

8. Install reservoir cap (Figure 35).

Replacing the Hydraulic Filter

Service Interval: Every 200 hours/Yearly (whichever comes first)—Replace the hydraulic filter.

1. Perform the steps in [Preparing for Maintenance \(page 19\)](#).
2. Clean area around filter and hydraulic manifold, align a drain pan under filter, and remove filter (Figure 36).

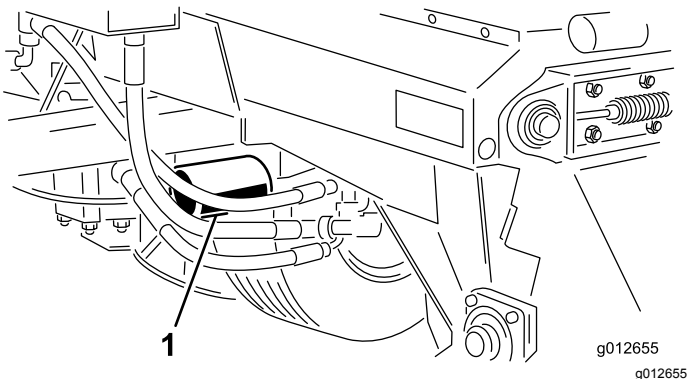

Figure 36

1. Hydraulic filter
-
3. Lubricate the gasket of the new filter with the specified hydraulic fluid; refer to [Hydraulic Fluid Specification \(page 27\)](#).
 4. Clean the filter-mounting area of the hydraulic manifold.
 5. Thread the filter onto the mount until gasket manifold, then tighten filter one-half turn.
 6. Tow machine to power the hydraulic system and check for hydraulic leaks.

Checking the Hydraulic Lines and Hoses

Service Interval: Before each use or daily

Inspect hydraulic lines and hoses daily for leaks, kinked lines, loose mounting supports, wear, loose fittings, weather deterioration and chemical deterioration. Make all necessary repairs before operating the machine.

Brush Maintenance

Checking the Brush for Position and Wear

Service Interval: Every 40 hours

Brush must make enough contact with conveyor belt to disperse top-dressing material but not restrict the rotation of the brush. A piece of stiff paper can be inserted between the conveyor belt and the brush to check the adjustment.

1. Insert a piece of stiff between the conveyor belt and the brush to check the adjustment.
2. Check that the brush is same height from side to side.
3. Check the condition of the brush bristles.

If the bristles are excessively worn replace the brush. If the bristles are worn uneven either replace the brush or adjust the brush position; refer to [Adjusting the Brush Position \(page 29\)](#).

Adjusting the Brush Position

Note: If you are using moist top-dressing material, you may need to adjust the brush position so that the bristles will whisk material from between conveyor belt lugs without excessively contacting smooth portion of belt.

1. Loosen nuts that secure the bearing housing (Figure 37) to right side of machine.

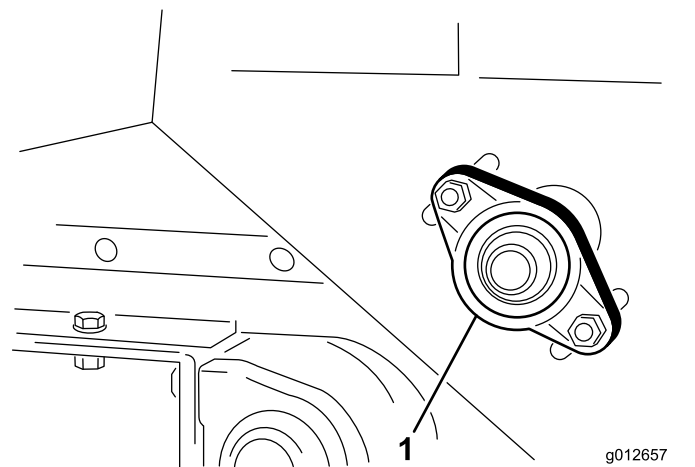

Figure 37

1. Bearing housing
-
2. Loosen nuts that secure the brush motor (Figure 38) to left side of machine.

Cleaning

Thoroughly clean the machine, especially inside the hopper. Clean the hopper and conveyor belt area free of any sand particles.

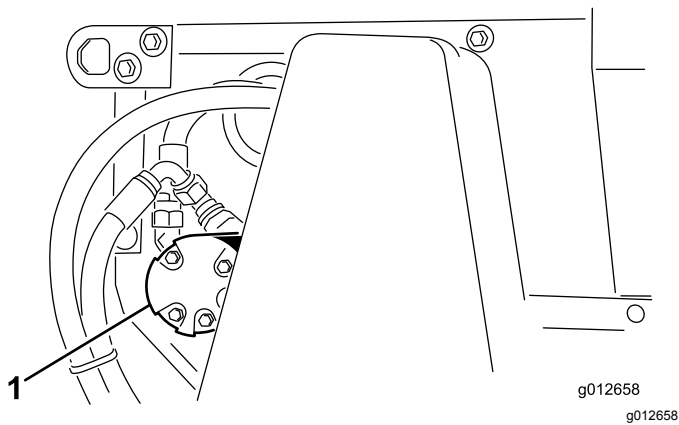

Figure 38

1. Brush motor

-
3. Slide brush into position at right side, and snug the nuts.
 4. Slide brush into position at left side, and snug the nuts.
 5. Insert a piece of stiff paper between the brush and the conveyor belt.

The brush must be the same height from side to side.

6. If the brush position is correct, tighten nuts.
If the brush position is not correct, repeat steps 1 through 6.

Storage

- Park the machine on a hard, level surface; engage the parking brake; shut off the engine; remove the key; and wait for all movement to stop before leaving the machine.
- When the optional jack is installed, rotate it from the horizontal (traveling) position, to the vertical position.
- Thoroughly clean the topdresser, especially inside the hopper. The hopper and conveyor belt area should be free of any remaining sand particles.
- Tighten all fasteners.
- Lubricate all grease fittings and bearings. Wipe off excess lubricant.
- The unit should be stored out of the sun to prolong the life of the conveyor belt. When stored outside it is recommended to cover the hopper with a tarp.
- Check the tension of the drive chain. Adjust the tension, if necessary.
- Check the tension of the conveyor belt. Adjust the tension, if necessary.
- When bringing topdresser out of storage, check for smooth operation of belt before adding material in hopper.

Troubleshooting

Problem	Possible Cause	Corrective Action
Difficulty in connecting or disconnecting control wires	<ol style="list-style-type: none"> 1. The traction unit has the wrong connector. 2. The on/off connections are switched with brake wiring. 	<ol style="list-style-type: none"> 1. Purchase an additional harness from your authorized Toro distributor. 2. Correct connections.
Topdresser is hard to pull with traction unit	<ol style="list-style-type: none"> 1. The wheel motors/pumps are not turning. 2. The brake solenoid is activated. 3. The hydraulic oil is hot. 	<ol style="list-style-type: none"> 1. The hydraulic plumbing is reversed. 2. Check the wiring. 3. Correct the condition.
Hydraulic leaks	<ol style="list-style-type: none"> 1. The fittings are loose. 2. The oil filter is loose. 3. A fitting is missing an O-ring. 4. The hydraulic fluid reservoir over filled. 	<ol style="list-style-type: none"> 1. Tighten the fittings. 2. Tighten the oil filter. 3. Install the missing O-ring. 4. Remove some hydraulic fluid from the reservoir.
Belt and/or brush does not function	<ol style="list-style-type: none"> 1. The solenoid wiring is not providing 12 volts. 2. The hand control handle switch is worn or damaged. 3. The hydraulic motors/pumps are not turning. 4. The conveyer belt slips. 	<ol style="list-style-type: none"> 1. Check the fuse and electrical connections. 2. Check for continuity through the switch and check diode in electrical solenoid connector. 3. Check the wheel-drive chain. 4. Check the conveyer belt tension.
Belt tracking	<ol style="list-style-type: none"> 1. The rollers do not have equal center distance. 2. The belt tension is incorrect. 3. The bearing lock collars securing roller are not tight. 4. The belt rib is not aligned the groove in rollers. 	<ol style="list-style-type: none"> 1. Adjust the side to side distance. 2. Make sure that the springs are compressed equally at each side of the machine. 3. Tighten the bearing lock collars. 4. Align the belt rib with the groove in rollers.

Schematics

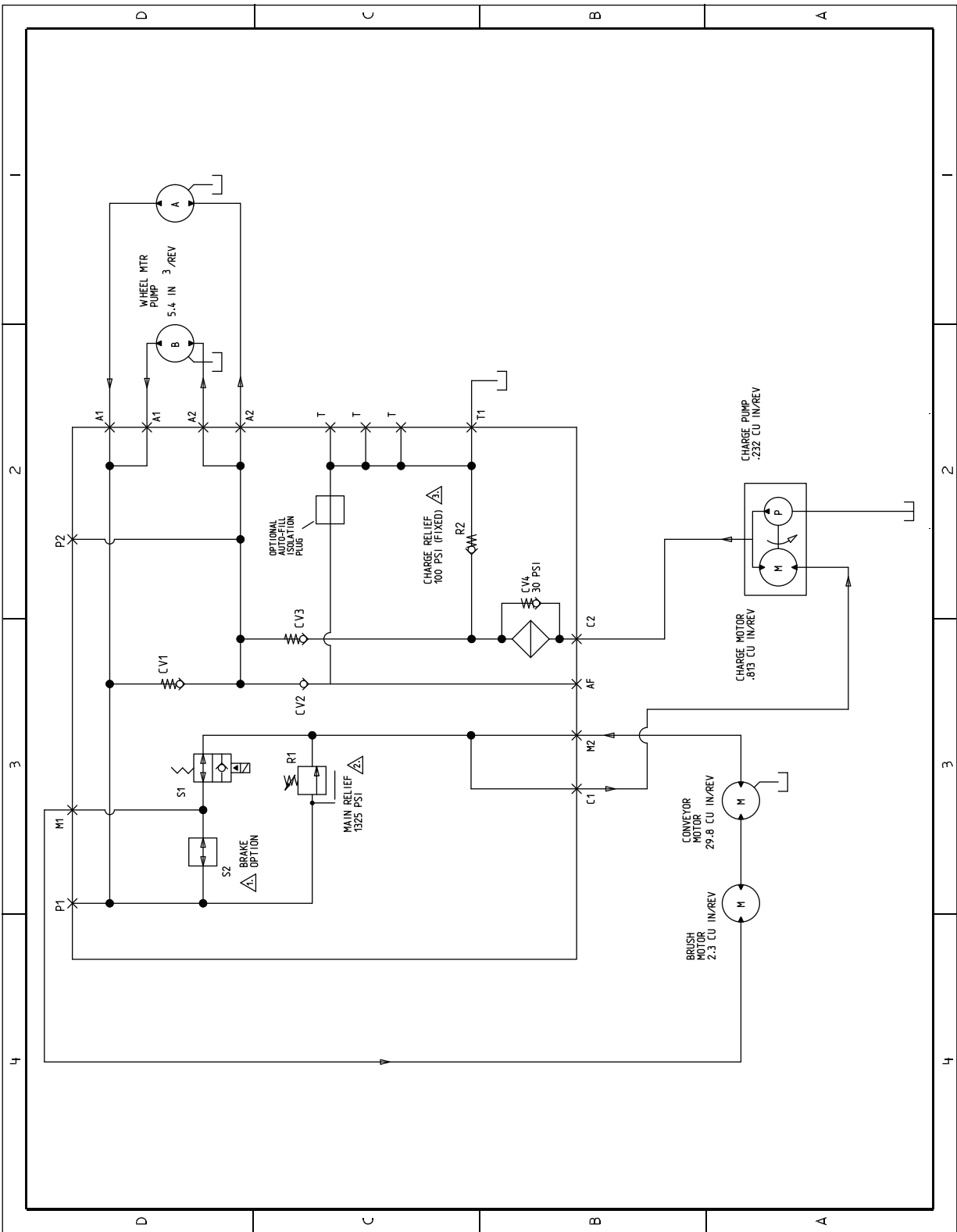

Hydraulic Schematic 106-9679 (Rev. D)

g269552

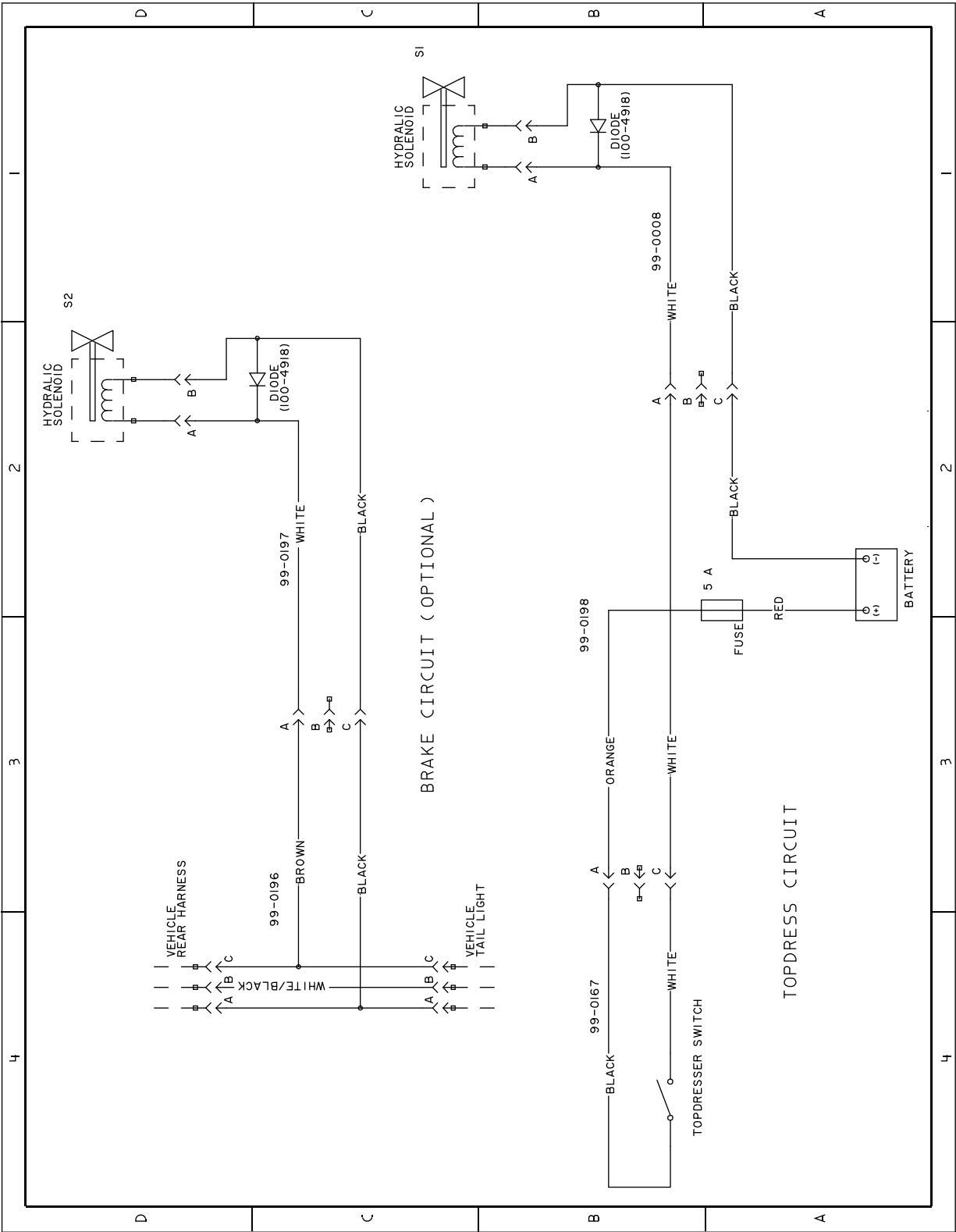

Electrical Schematic 100-7687 (Rev. A)

g269551

Notes:

Notes:

Notes:

EEA/UK Privacy Notice

Toro's Use of Your Personal Information

The Toro Company ("Toro") respects your privacy. When you purchase our products, we may collect certain personal information about you, either directly from you or through your local Toro company or dealer. Toro uses this information to fulfil contractual obligations - such as to register your warranty, process your warranty claim or to contact you in the event of a product recall - and for legitimate business purposes - such as to gauge customer satisfaction, improve our products or provide you with product information which may be of interest. Toro may share your information with our subsidiaries, affiliates, dealers or other business partners in connection these activities. We may also disclose personal information when required by law or in connection with the sale, purchase or merger of a business. We will never sell your personal information to any other company for marketing purposes.

Retention of your Personal Information

Toro will keep your personal information as long as it is relevant for the above purposes and in accordance with legal requirements. For more information about applicable retention periods please contact legal@toro.com.

Toro's Commitment to Security

Your personal information may be processed in the US or another country which may have less strict data protection laws than your country of residence. Whenever we transfer your information outside of your country of residence, we will take legally required steps to ensure that appropriate safeguards are in place to protect your information and to make sure it is treated securely.

Access and Correction

You may have the right to correct or review your personal data, or object to or restrict the processing of your data. To do so, please contact us by email at legal@toro.com. If you have concerns about the way in which Toro has handled your information, we encourage you to raise this directly with us. Please note that European residents have the right to complain to your Data Protection Authority.

California Proposition 65 Warning Information

What is this warning?

You may see a product for sale that has a warning label like the following:



WARNING: Cancer and Reproductive Harm—www.p65Warnings.ca.gov.

What is Prop 65?

Prop 65 applies to any company operating in California, selling products in California, or manufacturing products that may be sold in or brought into California. It mandates that the Governor of California maintain and publish a list of chemicals known to cause cancer, birth defects, and/or other reproductive harm. The list, which is updated annually, includes hundreds of chemicals found in many everyday items. The purpose of Prop 65 is to inform the public about exposure to these chemicals.

Prop 65 does not ban the sale of products containing these chemicals but instead requires warnings on any product, product packaging, or literature with the product. Moreover, a Prop 65 warning does not mean that a product is in violation of any product safety standards or requirements. In fact, the California government has clarified that a Prop 65 warning "is not the same as a regulatory decision that a product is 'safe' or 'unsafe.'" Many of these chemicals have been used in everyday products for years without documented harm. For more information, go to <https://oag.ca.gov/prop65/faqs-view-all>.

A Prop 65 warning means that a company has either (1) evaluated the exposure and has concluded that it exceeds the "no significant risk level"; or (2) has chosen to provide a warning based on its understanding about the presence of a listed chemical without attempting to evaluate the exposure.

Does this law apply everywhere?

Prop 65 warnings are required under California law only. These warnings are seen throughout California in a wide range of settings, including but not limited to restaurants, grocery stores, hotels, schools, and hospitals, and on a wide variety of products. Additionally, some online and mail order retailers provide Prop 65 warnings on their websites or in catalogs.

How do the California warnings compare to federal limits?

Prop 65 standards are often more stringent than federal and international standards. There are various substances that require a Prop 65 warning at levels that are far lower than federal action limits. For example, the Prop 65 standard for warnings for lead is 0.5 µg/day, which is well below the federal and international standards.

Why don't all similar products carry the warning?

- Products sold in California require Prop 65 labelling while similar products sold elsewhere do not.
- A company involved in a Prop 65 lawsuit reaching a settlement may be required to use Prop 65 warnings for its products, but other companies making similar products may have no such requirement.
- The enforcement of Prop 65 is inconsistent.
- Companies may elect not to provide warnings because they conclude that they are not required to do so under Prop 65; a lack of warnings for a product does not mean that the product is free of listed chemicals at similar levels.

Why does Toro include this warning?

Toro has chosen to provide consumers with as much information as possible so that they can make informed decisions about the products they buy and use. Toro provides warnings in certain cases based on its knowledge of the presence of one or more listed chemicals without evaluating the level of exposure, as not all the listed chemicals provide exposure limit requirements. While the exposure from Toro products may be negligible or well within the "no significant risk" range, out of an abundance of caution, Toro has elected to provide the Prop 65 warnings. Moreover, if Toro does not provide these warnings, it could be sued by the State of California or by private parties seeking to enforce Prop 65 and subject to substantial penalties.



The Toro Warranty

A Two-Year Limited Warranty

Conditions and Products Covered

The Toro Company and its affiliate, Toro Warranty Company, pursuant to an agreement between them, jointly warrant your Toro Commercial product ("Product") to be free from defects in materials or workmanship for two years or 1500 operational hours*, whichever occurs first. This warranty is applicable to all products with the exception of Aerators (refer to separate warranty statements for these products). Where a warrantable condition exists, we will repair the Product at no cost to you including diagnostics, labor, parts, and transportation. This warranty begins on the date the Product is delivered to the original retail purchaser.

* Product equipped with an hour meter.

Instructions for Obtaining Warranty Service

You are responsible for notifying the Commercial Products Distributor or Authorized Commercial Products Dealer from whom you purchased the Product as soon as you believe a warrantable condition exists. If you need help locating a Commercial Products Distributor or Authorized Dealer, or if you have questions regarding your warranty rights or responsibilities, you may contact us at:

Toro Commercial Products Service Department
Toro Warranty Company
8111 Lyndale Avenue South
Bloomington, MN 55420-1196
952-888-8801 or 800-952-2740
E-mail: commercial.warranty@toro.com

Owner Responsibilities

As the Product owner, you are responsible for required maintenance and adjustments stated in your *Operator's Manual*. Failure to perform required maintenance and adjustments can be grounds for disallowing a warranty claim.

Items and Conditions Not Covered

Not all product failures or malfunctions that occur during the warranty period are defects in materials or workmanship. This warranty does not cover the following:

- Product failures which result from the use of non-Toro replacement parts, or from installation and use of add-on, or modified non-Toro branded accessories and products. A separate warranty may be provided by the manufacturer of these items.
- Product failures which result from failure to perform recommended maintenance and/or adjustments. Failure to properly maintain your Toro product per the Recommended Maintenance listed in the *Operator's Manual* can result in claims for warranty being denied.
- Product failures which result from operating the Product in an abusive, negligent, or reckless manner.
- Parts subject to consumption through use unless found to be defective. Examples of parts which are consumed, or used up, during normal Product operation include, but are not limited to, brake pads and linings, clutch linings, blades, reels, rollers and bearings (sealed or greasable), bed knives, spark plugs, castor wheels and bearings, tires, filters, belts, and certain sprayer components such as diaphragms, nozzles, and check valves, etc.
- Failures caused by outside influence. Conditions considered to be outside influence include, but are not limited to, weather, storage practices, contamination, use of unapproved fuels, coolants, lubricants, additives, fertilizers, water, or chemicals, etc.
- Failure or performance issues due to the use of fuels (e.g. gasoline, diesel, or biodiesel) that do not conform to their respective industry standards.

Countries Other than the United States or Canada

Customers who have purchased Toro products exported from the United States or Canada should contact their Toro Distributor (Dealer) to obtain guarantee policies for your country, province, or state. If for any reason you are dissatisfied with your Distributor's service or have difficulty obtaining guarantee information, contact the Toro importer.

- Normal noise, vibration, wear and tear, and deterioration.
- Normal "wear and tear" includes, but is not limited to, damage to seats due to wear or abrasion, worn painted surfaces, scratched decals or windows, etc.

Parts

Parts scheduled for replacement as required maintenance are warranted for the period of time up to the scheduled replacement time for that part. Parts replaced under this warranty are covered for the duration of the original product warranty and become the property of Toro. Toro will make the final decision whether to repair any existing part or assembly or replace it. Toro may use remanufactured parts for warranty repairs.

Deep Cycle and Lithium-Ion Battery Warranty:

Deep cycle and Lithium-Ion batteries have a specified total number of kilowatt-hours they can deliver during their lifetime. Operating, recharging, and maintenance techniques can extend or reduce total battery life. As the batteries in this product are consumed, the amount of useful work between charging intervals will slowly decrease until the battery is completely worn out. Replacement of worn out batteries, due to normal consumption, is the responsibility of the product owner. Battery replacement may be required during the normal product warranty period at owner's expense. Note: (Lithium-Ion battery only): A Lithium-Ion battery has a part only prorated warranty beginning year 3 through year 5 based on the time in service and kilowatt hours used. Refer to the *Operator's Manual* for additional information.

Maintenance is at Owner's Expense

Engine tune-up, lubrication, cleaning and polishing, replacement of filters, coolant, and completing recommended maintenance are some of the normal services Toro products require that are at the owner's expense.

General Conditions

Repair by an Authorized Toro Distributor or Dealer is your sole remedy under this warranty.

Neither The Toro Company nor Toro Warranty Company is liable for indirect, incidental or consequential damages in connection with the use of the Toro Products covered by this warranty, including any cost or expense of providing substitute equipment or service during reasonable periods of malfunction or non-use pending completion of repairs under this warranty. Except for the Emissions warranty referenced below, if applicable, there is no other express warranty. All implied warranties of merchantability and fitness for use are limited to the duration of this express warranty.

Some states do not allow exclusions of incidental or consequential damages, or limitations on how long an implied warranty lasts, so the above exclusions and limitations may not apply to you. This warranty gives you specific legal rights, and you may also have other rights which vary from state to state.

Note regarding engine warranty:

The Emissions Control System on your Product may be covered by a separate warranty meeting requirements established by the U.S. Environmental Protection Agency (EPA) and/or the California Air Resources Board (CARB). The hour limitations set forth above do not apply to the Emissions Control System Warranty. Refer to the Engine Emission Control Warranty Statement supplied with your product or contained in the engine manufacturer's documentation for details.