



Count on it.

Operator's Manual

**Z Master[®] Professional 7000
Series Riding Mower**

**With 52in, 60in, and 72in TURBO FORCE[®]
Side Discharge Mower**

Model No. 74266—Serial No. 316000001 and Up

Model No. 74267—Serial No. 316000001 and Up

Model No. 74274—Serial No. 316000001 and Up

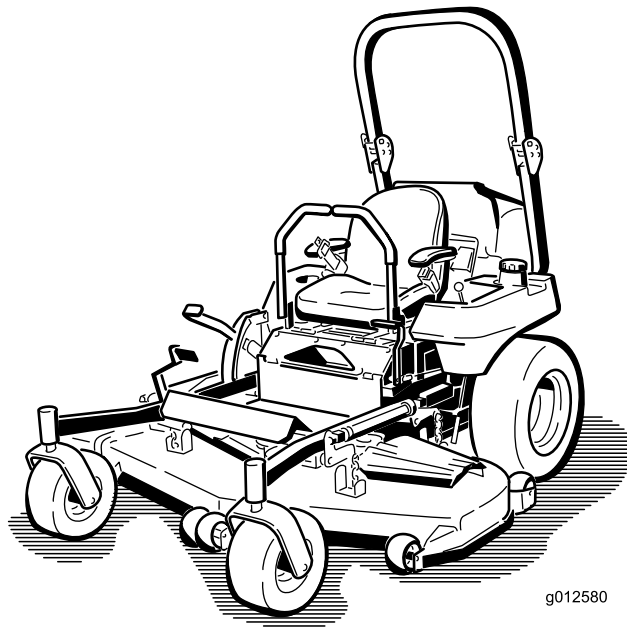

g012580



It is a violation of California Public Resource Code Section 4442 or 4443 to use or operate the engine on any forest-covered, brush-covered, or grass-covered land unless the engine is equipped with a spark arrester, as defined in Section 4442, maintained in effective working order or the engine is constructed, equipped, and maintained for the prevention of fire.

Please refer to the engine manufacturer's information included with the machine.

▲ WARNING

**CALIFORNIA
Proposition 65 Warning**

The engine exhaust from this product contains chemicals known to the State of California to cause cancer, birth defects, or other reproductive harm.

Introduction

This rotary-blade, riding lawn mower is intended to be used by residential homeowners or professional, hired operators. It is designed primarily for cutting grass on well-maintained lawns on residential or commercial properties. It is not designed for cutting brush or for agricultural uses.

Read this information carefully to learn how to operate and maintain your product properly and to avoid injury and product damage. You are responsible for operating the product properly and safely.

You may contact Toro directly at www.Toro.com for product safety and operation training materials, accessory information, help finding a dealer, or to register your product.

Whenever you need service, genuine Toro parts, or additional information, contact an Authorized Service Dealer or Toro Customer Service and have the model and serial numbers of your product ready. [Figure 1](#) identifies the location of the model and serial numbers on the product. Write the numbers in the space provided.

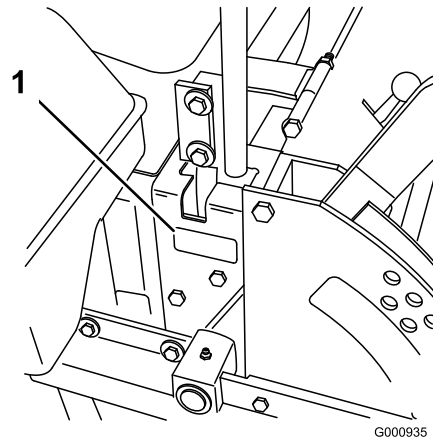

Figure 1

1. Model and serial number location

Model No. _____
Serial No. _____

This manual identifies potential hazards and has safety messages identified by the safety-alert symbol ([Figure 2](#)), which signals a hazard that may cause serious injury or death if you do not follow the recommended precautions.



Figure 2

1. Safety-alert symbol

This manual uses 2 words to highlight information. **Important** calls attention to special mechanical information and **Note** emphasizes general information worthy of special attention.

Contents

Safety	4	Lubricating the Caster-Wheel Hubs	40
General Safety	4	Engine Maintenance	41
Slope Indicator	5	Engine Safety	41
Safety and Instructional Decals	6	Servicing the Air Cleaner	41
Product Overview	15	Servicing the Engine Oil.....	42
Controls	15	Fuel System Maintenance	46
Before Operation	17	Servicing the Fuel Filter and Water	
Before Operation Safety	17	Seperator.....	46
Recommended Fuel	17	Servicing the Fuel Tank.....	47
Biodiesel Ready	18	Electrical System Maintenance	48
Filling the Fuel Tank.....	18	Electrical System Safety	48
Switching the Fuel Tanks	18	Servicing the Battery.....	48
Checking the Engine-Oil Level.....	18	Servicing the Fuses	49
Breaking in a New Machine	18	Drive System Maintenance	50
Using the Rollover Protection System		Adjusting the Tracking	50
(ROPS).....	18	Checking the Tire Pressure.....	51
Think Safety First.....	19	Checking the Wheel-Hub Slotted Nut.....	51
Using the Safety-Interlock System	20	Adjusting the Caster-Pivot Bearing	51
Positioning the Seat.....	21	Servicing the Gearbox	52
Unlatching the Seat	21	Adjusting the Electric Clutch	53
Changing the Seat Suspension.....	22	Cooling System Maintenance	54
During Operation	23	Servicing the Cooling System	54
During Operation Safety	23	Brake Maintenance	56
Operating the Parking Brake.....	24	Adjusting the Parking Brake.....	56
Operating the Mower Blade-Control Switch		Belt Maintenance	56
(PTO).....	24	Inspecting the Belts	56
Operating the Throttle.....	25	Replacing the Mower Belt	56
Operating the Ignition Switch	25	Adjusting the Mower Belt Tension	57
Starting and Shutting Off the Engine	25	Replacing the PTO-Drive Belt	58
Using the Motion-Control Levers.....	27	Replacing the Pump Drive Belt	59
Driving the Machine	27	Replacing and Tensioning the Alternator	
Stopping the Machine	29	Belt.....	59
Using the Side Discharge	29	Controls System Maintenance	61
Adjusting the Height of Cut	29	Adjusting the Control Handle Neutral	
Adjusting the Anti-Scalp Rollers.....	30	Position	61
Adjusting the Flow Baffle Cam Locks	30	Hydraulic System Maintenance	62
Positioning the Flow Baffle.....	31	Hydraulic System Safety.....	62
Operating with the Overheat Sensor	32	Servicing the Hydraulic System	62
Operating Tips	32	Setting the Hydraulic Pump Neutral	
After Operation	33	Position	66
After Operation Safety	33	Mower Deck Maintenance.....	68
Using the Fuel-Shutoff Valve.....	33	Leveling the Mower at 3 Positions	68
Pushing the Machine by Hand	33	Servicing the Cutting Blades.....	71
Transporting the Machine	34	Replacing the Grass Deflector	73
Loading the Machine	34	Cleaning	74
Maintenance	36	Cleaning under the Mower	74
Recommended Maintenance Schedule(s)	36	Waste Disposal.....	74
Pre-Maintenance Procedures	37	Storage	75
Maintenance and Storage.....	37	Cleaning and Storage	75
Lubrication	38	Troubleshooting	76
Greasing the Machine.....	38	Schematics	78
Greasing the Front Caster Pivots	38		
Adding Grease	38		
Adding Light Oil or Spray Lubrication	38		
Greasing the Mower Deck and Belt			
Idlers.....	39		

Safety

This machine has been designed in accordance with ANSI B71.4-2012.

General Safety

This product is capable of amputating hands and feet and of throwing objects. Always follow all safety instructions to avoid serious personal injury.

Using this product for purposes other than its intended use could prove dangerous to you and bystanders.

- Read and understand the contents of this *Operator's Manual* before you start the engine. Ensure that everyone using this product knows how to use it and understands the warnings.
- Do not put your hands or feet near moving components of the machine.
- Do not operate the machine without all guards and other safety protective devices in place and working on the machine.
- Keep clear of any discharge opening. Keep bystanders a safe distance away from the machine.
- Keep children out of the operating area. Never allow children to operate the machine.
- Stop the machine and shut off the engine before servicing, fueling, or unclogging the machine.

Improperly using or maintaining this machine can result in injury. To reduce the potential for injury, comply with these safety instructions and always pay attention to the safety-alert symbol, which means Caution, Warning, or Danger—personal safety instruction. Failure to comply with these instructions may result in personal injury or death.

You can find additional items of safety information in their respective sections throughout this manual.

Slope Indicator

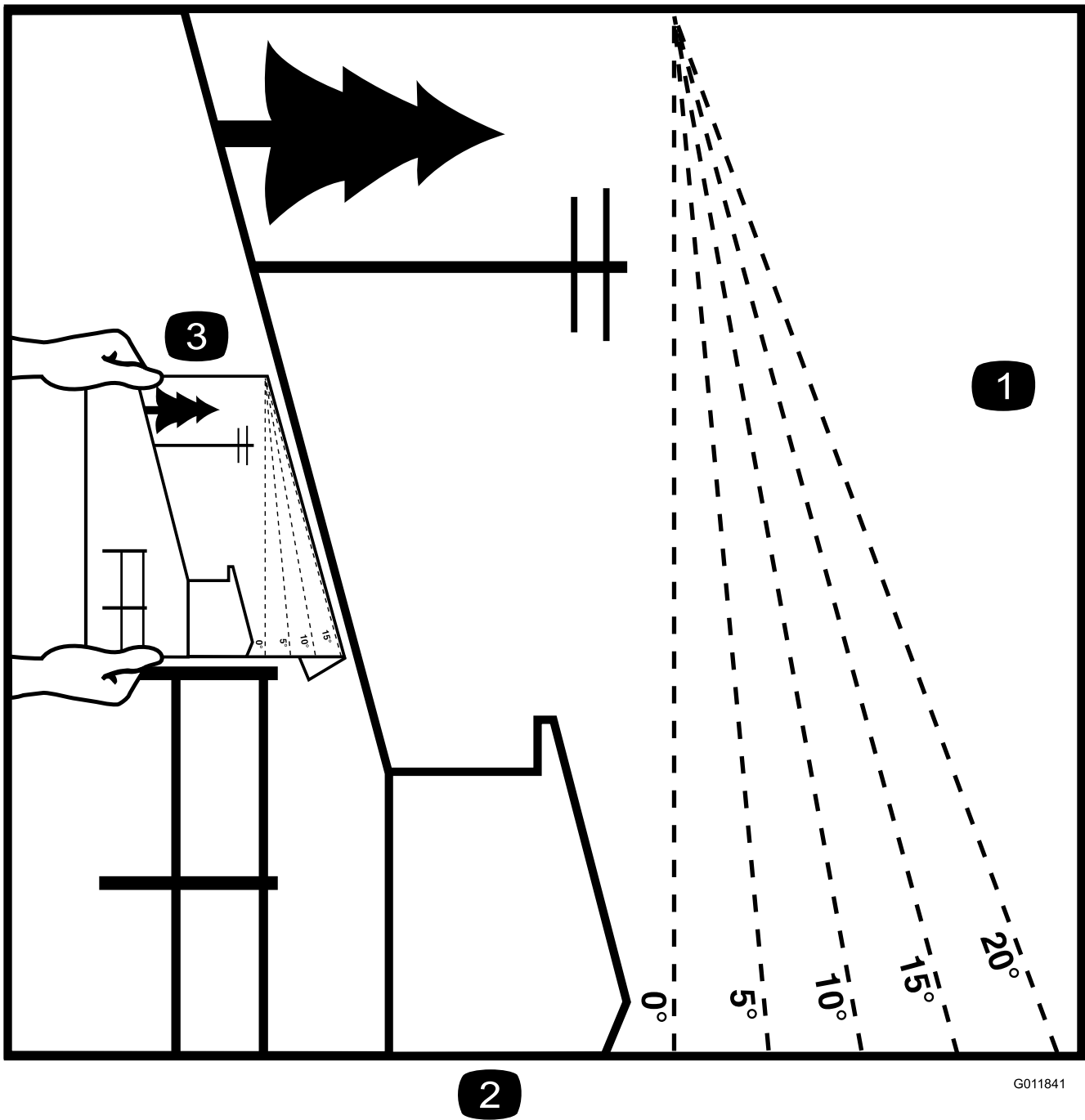

Figure 3

This page may be copied for personal use.

1. The maximum slope you can safely operate the machine on is **15 degrees**. Use the slope chart to determine the degree of slope of hills before operating. **Do not operate this machine on a slope greater than 15 degrees.** Fold along the appropriate line to match the recommended slope.
2. Align this edge with a vertical surface, a tree, building, fence pole, etc.
3. Example of how to compare slope with folded edge

Safety and Instructional Decals



Safety decals and instructions are easily visible to the operator and are located near any area of potential danger. Replace any decal that is damaged or missing.



1

58-6520

decal58-6520

1. Grease

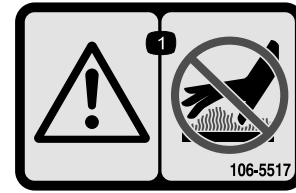

106-5517

decal106-5517

106-5517

1. Warning—do not touch the hot surface.

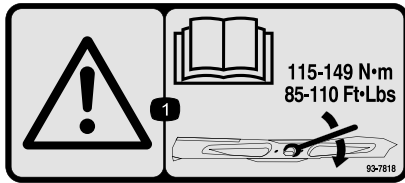

93-7818

decal93-7818

93-7818

1. Warning—read the *Operator's Manual* for instructions on torquing the blade bolt/nut to 115 to 149 N·m (85 to 110 ft-lb).



98-4387

decal98-4387

98-4387

1. Warning—wear hearing protection.

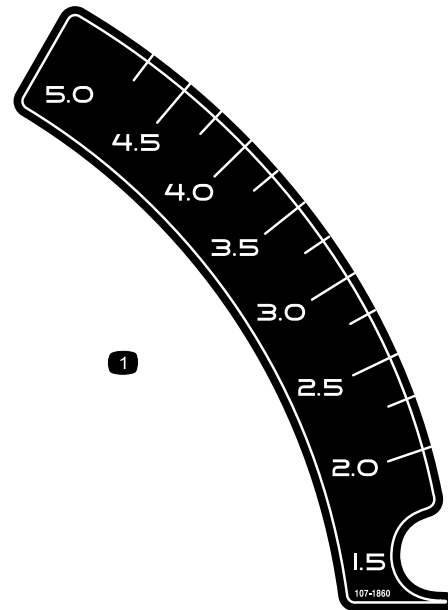

107-1860

decal107-1860

107-1860



DEX-COOL is a registered trademark of General Motors Corp. 104-2449

decal104-2449

104-2449

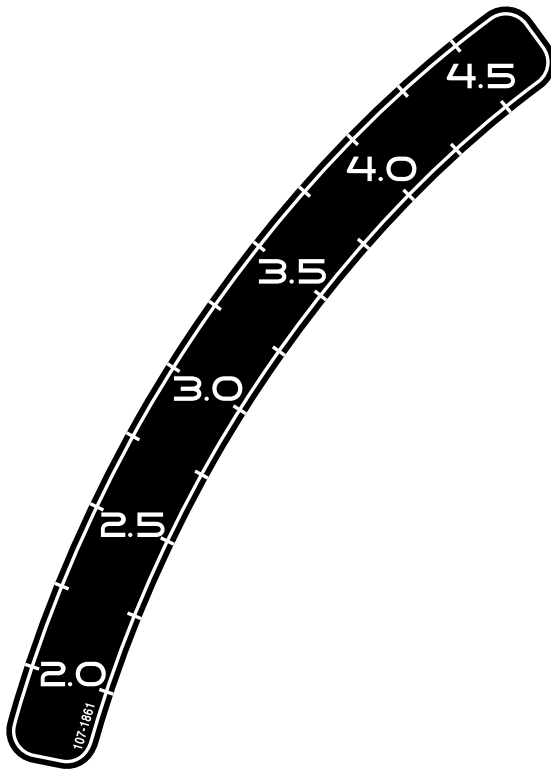

107-1861

decal107-1861

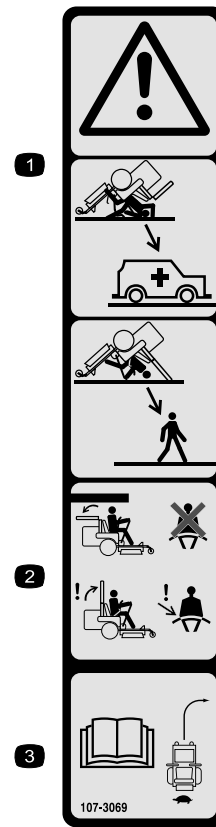

107-3069

decal107-3069

1. Warning—there is no rollover protection when the roll bar is down.
2. To avoid injury or death from a rollover accident, keep the roll bar in the raised and locked position and wear the seat belt. Lower the roll bar only when absolutely necessary; do not wear the seat belt when the roll bar is down.
3. Read the *Operator's Manual*; drive slowly and carefully.

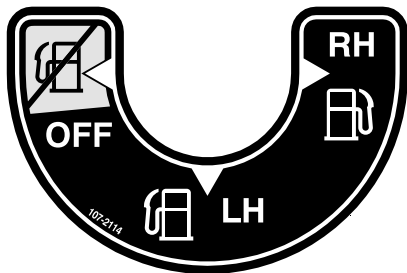

107-2114

decal107-2114

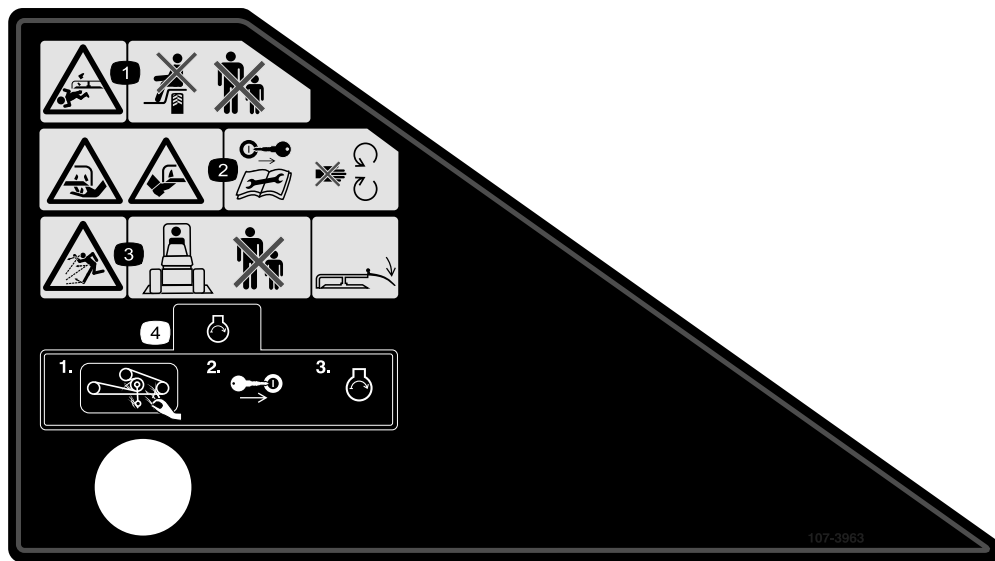

107-3963

decal107-3963

1. Cutting/dismemberment hazard, mower blade—do not carry passengers and keep bystanders away.
2. Cutting/dismemberment hazard of hand or foot, mower blade—remove the ignition key and read the instructions before servicing or performing maintenance; stay away from moving parts.
3. Thrown object hazard—keep bystanders a safe distance away from the machine and keep the deflector in place.
4. Before starting the engine, clean grass and debris from the mower belt and pulleys, insert the ignition key, and start the engine.

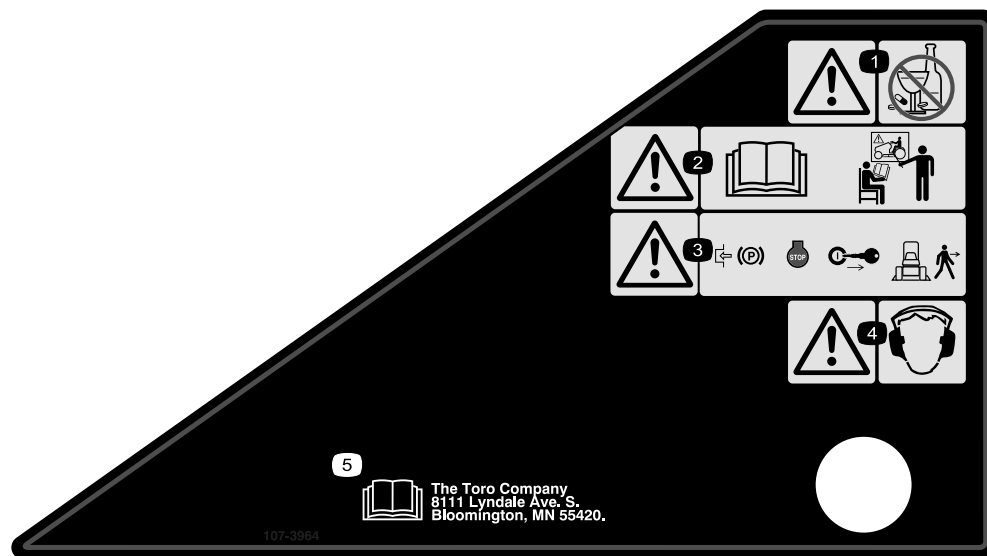

107-3964

decal107-3964

1. Warning—do not use drugs or alcohol.
2. Warning—read the *Operator's Manual* and receive training.
3. Warning—engage the parking brake, shut off the engine, and remove the ignition key before leaving the machine.
4. Warning—wear hearing protection.
5. Read the *Operator's Manual*.

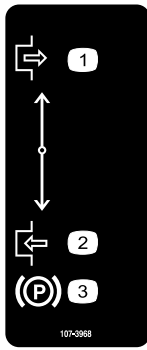

107-3968

decal107-3968

1. Disengage
2. Engage
3. Parking brake

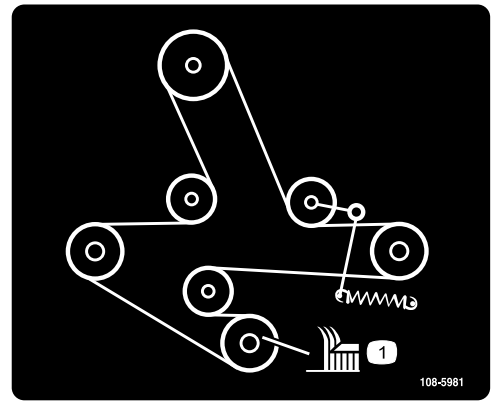

108-5981

decal108-5981

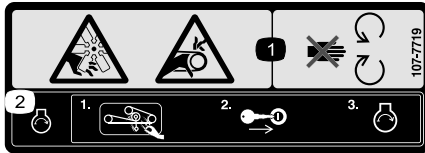

107-7719

decal107-7719

1. Cutting/dismemberment hazard, fan and entanglement hazard, belt—stay away from moving parts.
2. Before starting the engine, clean grass and debris from the mower belt and pulleys, insert the ignition key, and start the engine.

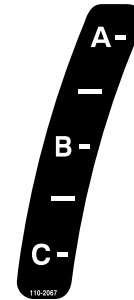

110-2067

decal110-2067

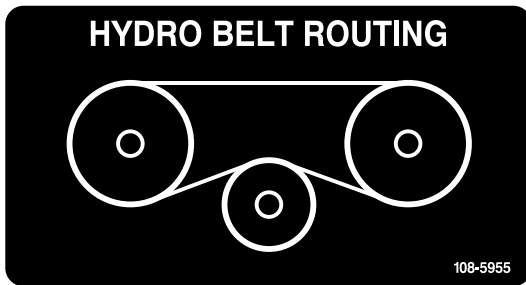

108-5955

decal108-5955

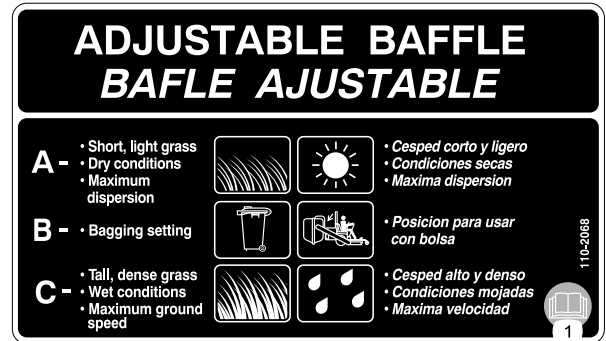

110-2068

decal110-2068

1. Read the *Operator's Manual*.

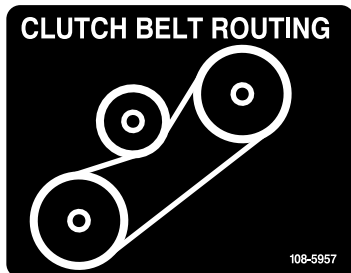

108-5957

decal108-5957

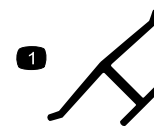

Manufacturer's Mark

decaloemmark

1. Indicates the blade is identified as a part from the original machine manufacturer.

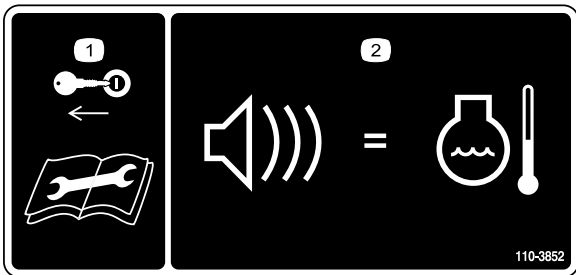

110-3852

decal110-3852

1. Remove the ignition key and read the instructions before servicing or performing maintenance.
2. Continuous tone signals the user that engine is overheating.

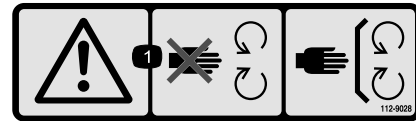

112-9028

decal112-9028

1. Warning—stay away from moving parts; keep all guards in place.

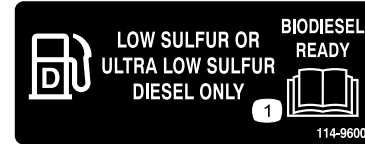

114-9600

decal114-9600

1. Read the *Operator's Manual*.

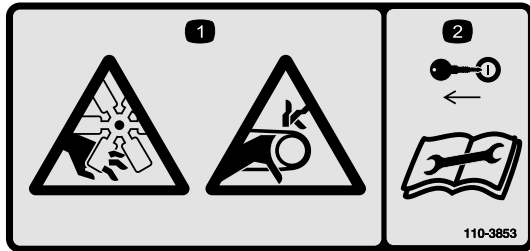

110-3853

decal110-3853

1. Cutting/dismemberment hazard, fan and entanglement hazard, belt.
2. Remove the ignition key and read the instructions before servicing or performing maintenance.

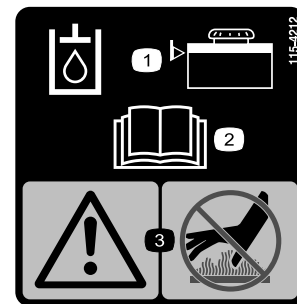

115-4212

decal115-4212

1. Hydraulic-fluid level
2. Read the *Operator's Manual*.
3. Warning—do not touch the hot surface.

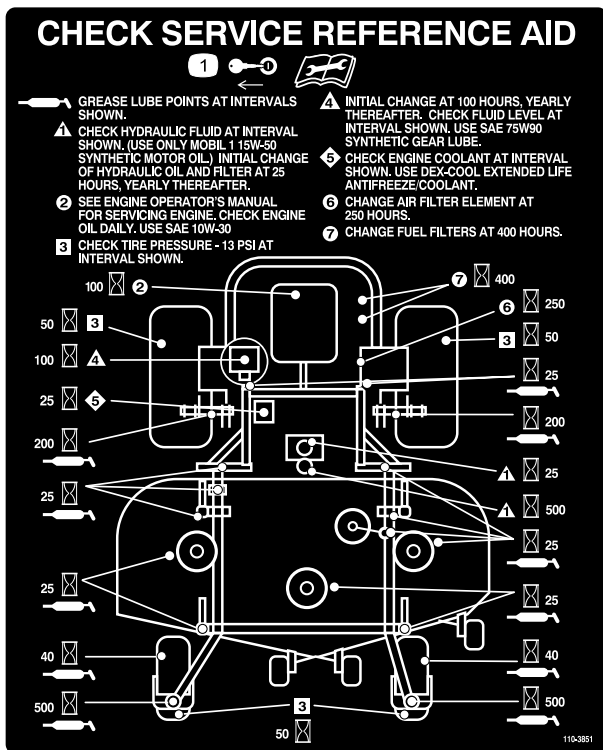

110-3851

decal110-3851

1. Remove the ignition key and read the instructions before servicing or performing maintenance.

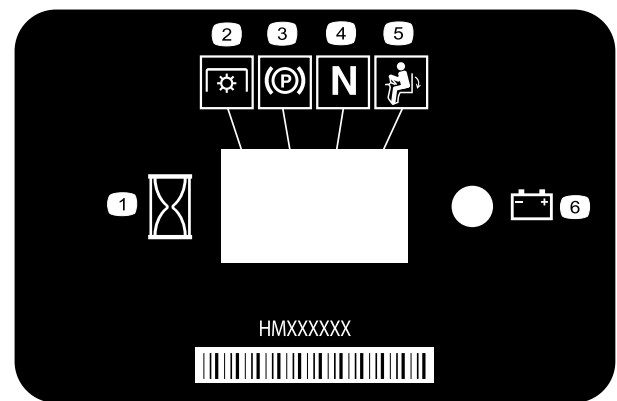

116-5610

decal116-5610

1. Hour meter
2. Power takeoff (PTO)
3. Parking brake
4. Neutral
5. Operator-presence switch
6. Battery

CALIFORNIA SPARK ARRESTER WARNING

Operation of this equipment may create sparks that can start fires around dry vegetation. A spark arrester may be required. The operator should contact local fire agencies for laws or regulations relating to fire prevention requirements. 117-2718

decal117-2718

117-2718



117-3848

decal117-3848

117-3848

1. Thrown object hazard—keep bystanders a safe distance away from the machine.
2. Thrown object hazard, mower—do not operate the machine without the deflector, discharge cover, or grass collection system in place.
3. Cutting/dismemberment of hand or foot—stay away from moving parts; keep all guards and shields in place.



decal119-0397

119-0397

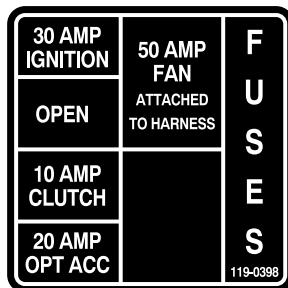

decal119-0398

119-0398

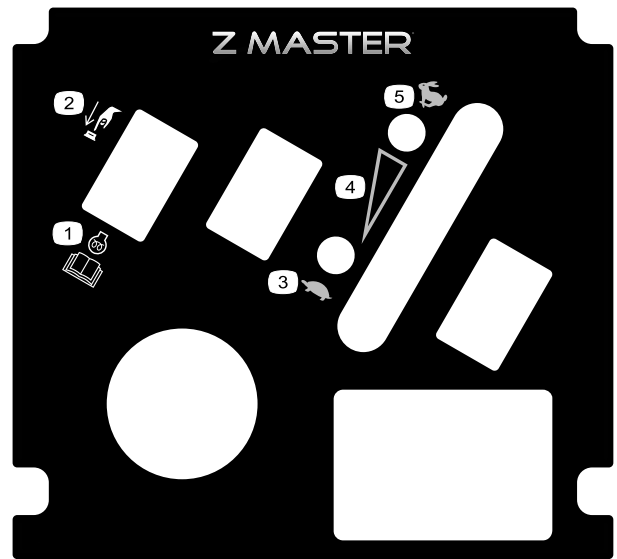

decal121-7562

121-7562

1. Push to start
2. Read the *Operator's Manual* for more information on preheating the engine.
3. Slow
4. Variable-speed control
5. Fast



decal126-2055

126-2055

1. Wheel-lug nut torque 129 N·m (95 ft-lb) (4x)
2. Wheel-hub nut torque 319 N·m (235 ft-lb)
3. Read and understand the Operator's manual before performing any maintenance, check torque after first 100 hours then every 500 hours thereafter.

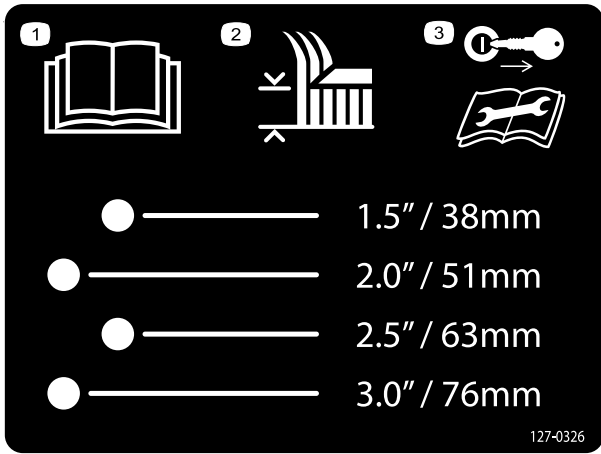

127-0326

decal127-0326

127-0326

1. Read the *Operator's Manual*.
2. Height of cut
3. Remove the key from the ignition and read the *Operator's Manual* before performing maintenance or servicing the machine.

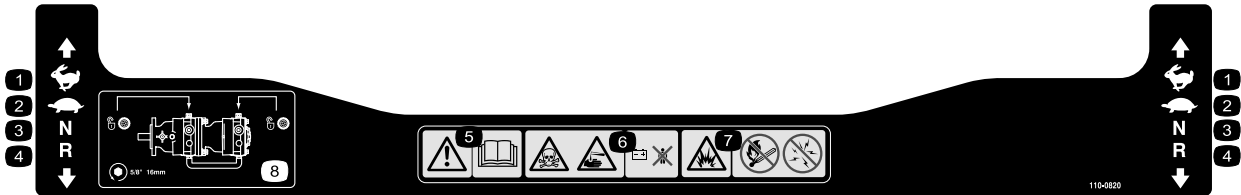

110-0820

decal110-0820

110-0820

1. Fast
2. Slow
3. Neutral
4. Reverse
5. Warning—read the *Operator's Manual*.
6. Poison and caustic liquid/chemical burn hazard—keep children a safe distance away from the battery.
7. Explosion hazard—no fire, open flames, or smoking; avoid sparks.
8. To unlock the traction drive, turn the bypass valve 1 complete revolution counterclockwise using a 16 mm (5/8 inch) wrench.

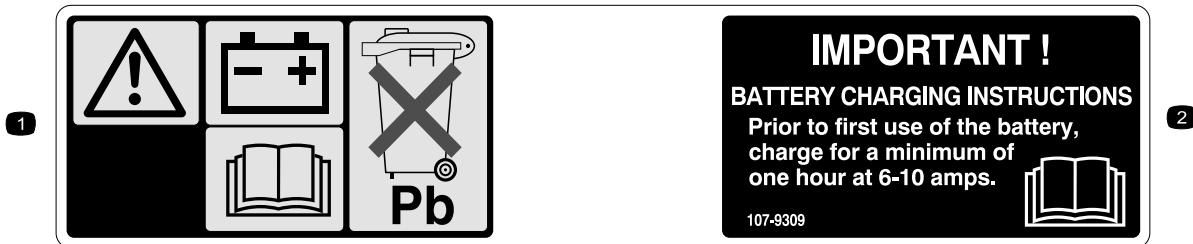

107-9309

decal107-9309

107-9309

1. Warning—read the *Operator's Manual* for information on charging the battery; contains lead; do not discard.
2. Read the *Operator's Manual*.



Battery Symbols

Some or all of these symbols are on your battery

- | | |
|--|---|
| 1. Explosion hazard | 6. Keep bystanders a safe distance away from the battery. |
| 2. No fire, open flame, or smoking | 7. Wear eye protection; explosive gases can cause blindness and other injuries. |
| 3. Caustic liquid/chemical burn hazard | 8. Battery acid can cause blindness or severe burns. |
| 4. Wear eye protection. | 9. Flush eyes immediately with water and get medical help fast. |
| 5. Read the <i>Operator's Manual</i> . | 10. Contains lead; do not discard |
-

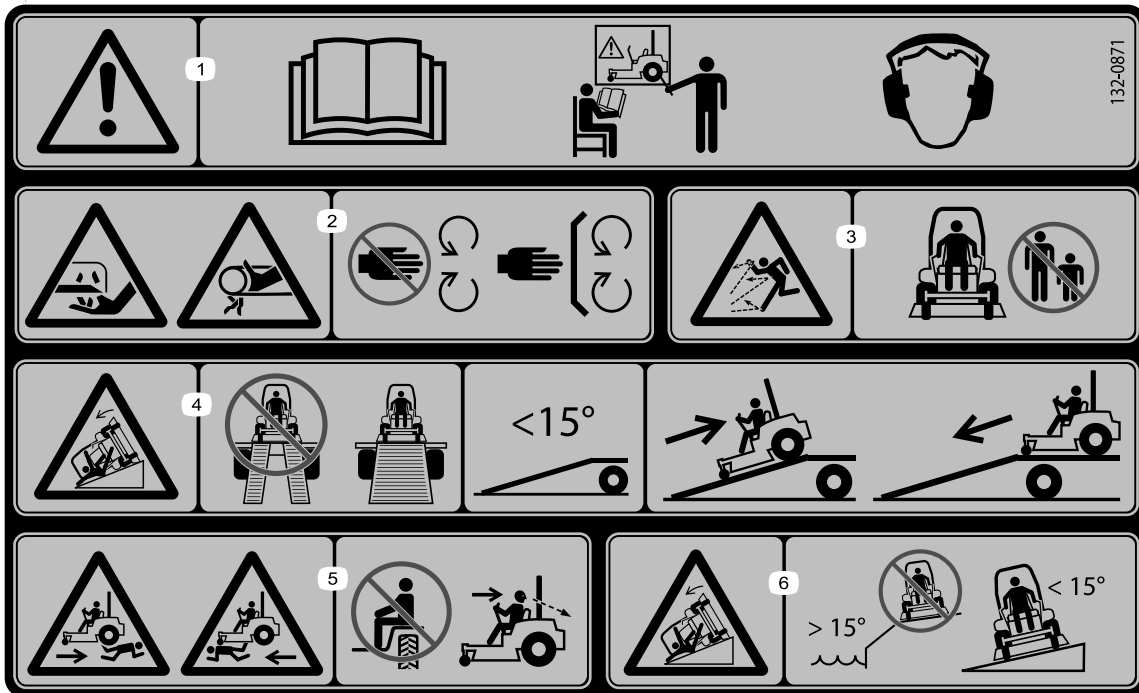

132-0871

decal132-0871

Note: This machine complies with the industry standard stability test in the static lateral and longitudinal tests with the maximum recommended slope indicated on the decal. Review the instructions for operating the machine on slopes in the *Operator's Manual* as well as the conditions in which you would operate the machine to determine whether you can operate the machine in those conditions on that day and at that site. Changes in the terrain can result in a change in slope operation for the machine. If possible, keep the cutting units lowered to the ground while operating the machine on slopes. Raising the cutting units while operating on slopes can cause the machine to become unstable.

1. Warning—read the *Operator's Manual*; do not operate this machine unless you are trained; wear hearing protection.
2. Cutting, dismembering, and entanglement hazard—keep hands away from moving parts; keep all guards and shields in place.
3. Thrown object hazard—keep bystanders away.
4. Ramp hazard—when loading onto a trailer, do not use dual ramps; only use a singular ramp wide enough for the machine and that has an incline less than 15° ; back up the ramp (in reverse) and drive forward off the ramp.
5. Bodily harm hazard—do not carry passengers; look behind you when mowing in reverse.
6. Tipping hazard on slopes—do not use on slopes near open water; do not use on slopes greater than 15° .

Product Overview

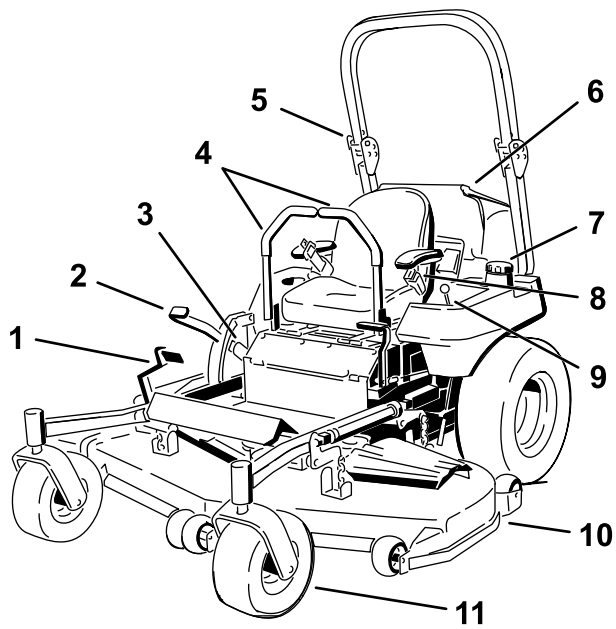
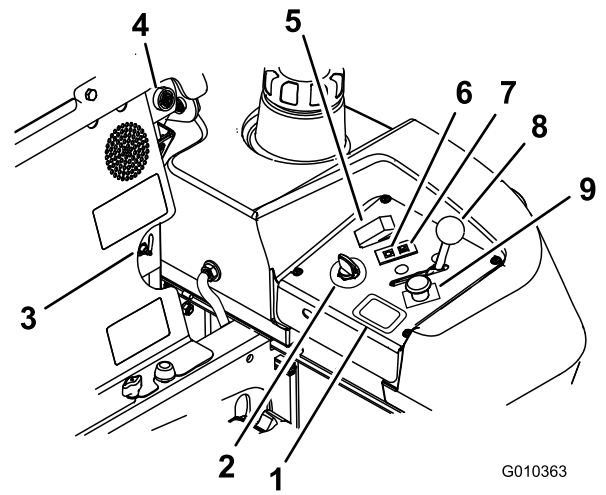

Figure 4

g208514

- | | |
|----------------------------------|------------------|
| 1. Height-of-cut deck lift pedal | 7. Fuel cap |
| 2. Parking-brake lever | 8. Seat belt |
| 3. Transport lock | 9. Controls |
| 4. Motion-control lever | 10. Mower deck |
| 5. Roll bar | 11. Caster wheel |
| 6. Engine screen | |



G010363

g010363

Figure 5

- | | |
|------------------------|-----------------------------|
| 1. Hour meter | 6. Glow-plug light |
| 2. Ignition switch | 7. Engine-temperature light |
| 3. Fuel-selector valve | 8. Throttle control |
| 4. Audible alarm | 9. PTO switch |
| 5. Glow-plug switch | |

Controls

Become familiar with all of the controls before you start the engine and operate the machine (Figure 4 and Figure 5).

Hour Meter

The hour meter records the number of hours the engine has operated. It operates when the engine is running. Use these times for scheduling regular maintenance (Figure 5).

Safety-Interlock Indicators

There are symbols on the hour meter that indicate with a black triangle that the interlock component is positioned correctly (Figure 6).

Battery-Indicator Light

When you turn the ignition key initially to the RUN position for a few seconds, the battery voltage is displayed in the area where the hours are normally displayed.

The battery light turns on when you turn on the ignition and the charge is below the correct operating level (Figure 6).

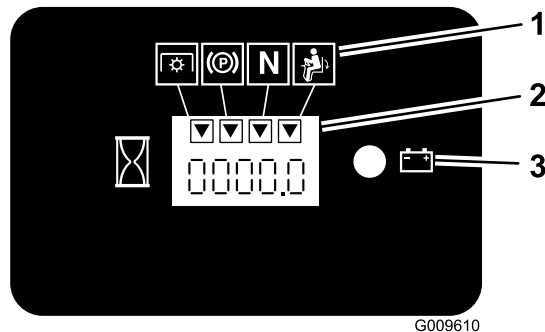

Figure 6

1. Safety-interlock symbols
2. Hour meter
3. Battery light

Throttle Control

The throttle controls the engine speed, and it has a continuous-variable setting from the SLOW to FAST position (Figure 5).

Blade-Control Switch (Power Takeoff)

The blade-control switch (PTO) engages and disengages power to the mower blades (Figure 5).

Neutral-Lock Position

The NEUTRAL-LOCK position is used with the safety-interlock system and to determine NEUTRAL position.

Ignition Switch

Use this switch to start the mower engine. It has 3 positions: START, RUN, and OFF.

Glow-Plug Light

The glow-plug-indicator light illuminates when you engage the glow-plug button (Figure 5).

Glow-Plug Switch

This switch activates the glow plugs and is indicated by the glow-plug light. Hold down the glow-plug switch for 10 seconds prior to starting.

Engine-Temperature Light

The temperature light comes on when the engine is over heating (Figure 5).

Audible Alarm

This machine has an audible alarm that alerts the user to turn off the engine. Otherwise, engine damage can occur from over heating; refer to [Cooling System Maintenance \(page 54\)](#).

Fuel-Selector Valve

The fuel-selector valve is located behind the seat.

Close the fuel-selector valve when transporting or storing the machine.

Move the selector valve to the left or right position for operation.

Attachments/Accessories

A selection of Toro approved attachments and accessories is available for use with the machine to enhance and expand its capabilities. Contact your Authorized Service Dealer or Distributor or go to www.Toro.com for a list of all approved attachments and accessories.

Operation

Note: Determine the left and right sides of the machine from the normal operating position.

Before Operation

Before Operation Safety

General Safety

- Never allow children or untrained people to operate or service the machine. Local regulations may restrict the age of the operator. The owner is responsible for training all operators and mechanics.
- Become familiar with the safe operation of the equipment, operator controls, and safety signs.
- Know how to stop the machine and engine quickly.
- Check that operator-presence controls, safety switches, and shields are attached and functioning properly. Do not operate the machine unless they are functioning properly.
- Before mowing, always inspect the machine to ensure that the blades, blade bolts, and cutting assemblies are in good working condition. Replace worn or damaged blades and bolts in sets to preserve balance.
- Inspect the area where you will use the machine and remove all objects that the machine could throw.
- Evaluate the terrain to determine the appropriate equipment and any attachments or accessories required to operate the machine properly and safely.

Fuel Safety

- To avoid personal injury or property damage, use extreme care in handling fuel. Fuel vapors are flammable and explosive.
- Extinguish all cigarettes, cigars, pipes, and other sources of ignition.
- Use only an approved fuel container.
- Do not remove the fuel cap or add fuel to the fuel tank while the engine is running or while hot.
- Do not refuel the machine indoors.
- Do not store the machine or fuel container where there is an open flame, spark, or pilot light, such as on a water heater or on other appliances.
- Do not fill containers inside a vehicle or on a truck or trailer bed with a plastic liner. Always place

containers on the ground, away from your vehicle before filling.

- Remove the equipment from the truck or trailer and refuel it while it is on the ground. If this is not possible, then refuel from a portable container rather than a fuel-dispenser nozzle.
- Do not operate the machine without the entire exhaust system in place and in proper working condition.
- Keep the fuel-dispenser nozzle in contact with the rim of the fuel tank or container opening at all times until fueling is complete. Do not use a nozzle lock-open device.
- If you spill fuel on your clothing, change your clothing immediately. Wipe up any fuel that spills.
- Never overfill the fuel tank. Replace the fuel cap and tighten it securely.
- Store fuel in an approved container and keep it out of the reach of children. Never buy more than a 30-day supply of fuel.
- Do not fill the fuel tank completely full. Add fuel to the fuel tank until the level is 6 to 13 mm (1/4 to 1/2 inch) below the bottom of the filler neck. This empty space in the tank allows fuel to expand.
 - Avoid prolonged breathing of vapors.
 - Keep your face away from the nozzle and fuel tank opening.
 - Avoid contact with skin; wash off spills with soap and water.

Recommended Fuel

The engine runs on clean, fresh diesel fuel with a minimum octane rating of 40. Purchase fuel in quantities that can be used within 30 days to ensure fuel freshness.

Use summer-grade diesel fuel (No. 2-D) at temperatures above -7°C (20°F) and winter-grade diesel fuel (No. 1-D or No. 1-D/2-D blend) below -7°C (20°F). Use of winter-grade diesel fuel at lower temperatures provides lower flash point and pour point characteristics, therefore easing startability and lessening chances of chemical separation of the fuel due to lower temperatures (wax appearance, which may plug filters).

Using summer-grade diesel fuel above -7°C (20°F) contributes toward longer life of the pump components.

Important: Do not use kerosene or gasoline instead of diesel fuel. Failure to observe this caution will damage the engine.

Biodiesel Ready

This machine can also use a biodiesel blended fuel of up to B20 (20% biodiesel, 80% petrodiesel). The petrodiesel portion should be low or ultra low sulfur.

Observe the following precautions:

- The biodiesel portion of the fuel meet specification ASTM D6751 or EN14214.
- The blended fuel composition should meet ASTM D975 or EN590.
- Painted surfaces may be damaged by biodiesel blends.
- Use B5 (biodiesel content of 5%) or lesser blend in cold weather.
- Monitor seals, hoses, gaskets in contact with fuel as they may degrade over time.
- Fuel filter plugging may be expected for a time after converting to biodiesel blends.
- Contact your distributor if you wish for more information on biodiesel.

Filling the Fuel Tank

1. Park the machine on level ground.
2. Shut off the engine and engage the parking brake.
3. Clean around the fuel-tank cap.
4. Fill the fuel tank to the bottom of the filler neck.

Note: Do not fill the fuel tank completely full. Fill the fuel tank to the bottom of the filler neck. The empty space in the tank allows the fuel to expand.

Switching the Fuel Tanks

Important: Do not allow the machine to run out of fuel, as this can damage the machine.

The fuel-selector valve is located behind the left side of the seat.

The unit has 2 fuel tanks. There is a tank each on the left and right sides. Each tank connects to the fuel-selector valve. From there a common fuel line leads to the engine (Figure 7).

To use the left fuel tank, rotate the fuel-selector valve to the left. To use the right fuel tank, rotate the fuel-selector valve to the right (Figure 7).

Close the fuel-selector valve before transporting or storing machine.

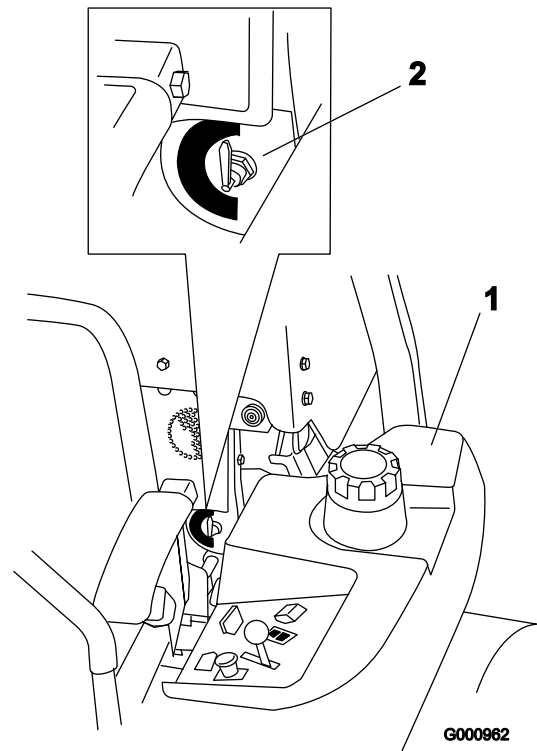

Figure 7

1. Left fuel tank

2. Fuel-selector valve

Checking the Engine-Oil Level

Before you start the engine and use the machine, check the oil level in the engine crankcase; refer to [Checking the Engine-Oil Level \(page 18\)](#).

Breaking in a New Machine

New engines take time to develop full power. Mower decks and drive systems have higher friction when new, placing additional load on the engine. Allow 40 to 50 hours of break-in time for new machines to develop full power and best performance.

Using the Rollover Protection System (ROPS)

⚠ WARNING

To avoid injury or death from rollover: keep the roll bar in the raised locked position and use the seat belt.

Ensure that the rear part of the seat is secured with the seat latch.

⚠ WARNING

There is no rollover protection when the roll bar is in the down position.

- Lower the roll bar only when absolutely necessary.
- Do not wear the seat belt when the roll bar is in the down position.
- Drive slowly and carefully.
- Raise the roll bar as soon as clearance permits.
- Check carefully for overhead clearances (i.e., branches, doorways, electrical wires) before driving under any objects and do not contact them.

Important: Lower the roll bar only when absolutely necessary.

1. Remove the hairpin cotters and remove the 2 pins (Figure 9).
2. Lower the roll bar to the down position (Figure 8).

Note: There are 2 down positions; refer to Figure 8.

3. Install the 2 pins and secure them with the hairpin cotters (Figure 9).

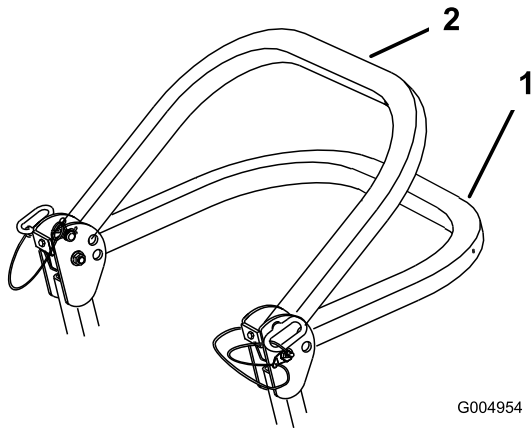

Figure 8

1. Full-down position
2. Down position with the bagger installed

Important: Ensure that you secure the rear part of the seat with the seat latch.

4. To raise the roll bar, remove the hairpin cotters and remove the 2 pins (Figure 9).
5. Raise the roll bar to the upright position, install the 2 pins, and secure them with the hairpin cotters (Figure 9).

Important: Always use the seat belt with the roll bar in the raised position.

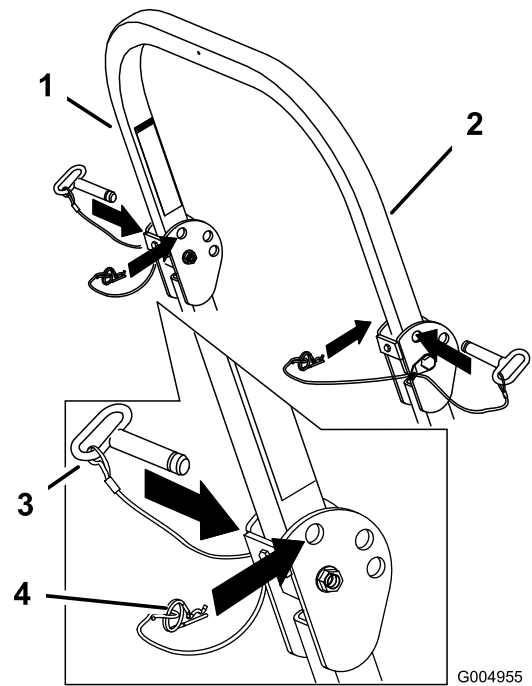

Figure 9

1. Roll bar
2. Raised position
3. Pin
4. Hairpin cotter

Think Safety First

Please read all safety instructions and symbols in the safety section. Knowing this information could help you or bystanders avoid injury.

⚠ DANGER

Operating the machine on wet grass or steep slopes can cause sliding and loss of control.

- Do not operate on slopes greater than 15 degrees.
- Reduce speed and use extreme caution on slopes.
- Do not operate the machine near water.

⚠ DANGER

Wheels dropping over edges can cause rollovers, which may result in serious injury, death, or drowning.

Do not operate the machine near drop-offs.

⚠ DANGER

Operating the machine while the roll bar is down may lead to serious injury or death in the event of a rollover.

Always keep the roll bar in the fully raised and locked position and use the seat belt.

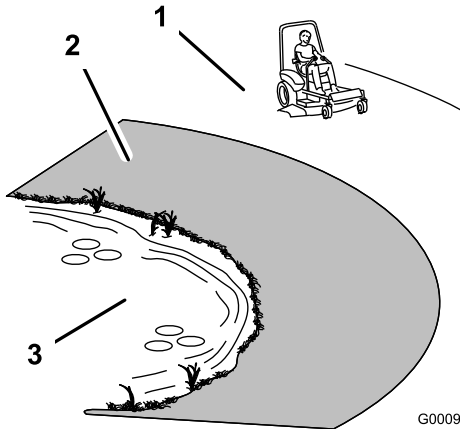

Figure 10

1. Safe Zone—use the machine here on slopes less than 15 degrees or flat areas.
2. Danger Zone—use a walk-behind mower and/or a hand trimmer on slopes greater than 15 degrees and near drop-offs or water.
3. Water

⚠ CAUTION

This machine produces sound levels in excess of 85 dBA at the operator's ear and can cause hearing loss through extended periods of exposure.

Wear hearing protection when operating this machine.

Use protective equipment for your eyes, ears, hands, feet, and head.

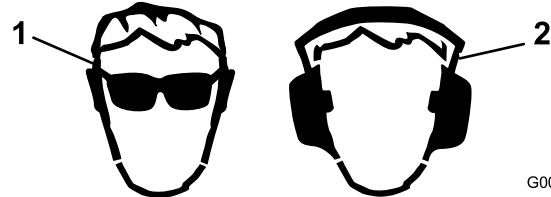

Figure 11

1. Wear eye protection.
2. Wear hearing protection.

Using the Safety-Interlock System

⚠ WARNING

If safety-interlock switches are disconnected or damaged, the machine could operate unexpectedly causing personal injury.

- Do not tamper with the interlock switches.
- Check the operation of the interlock switches daily, and replace any damaged switches before operating the machine.

Understanding the Safety-Interlock System

The safety-interlock system is designed to prevent the engine from starting unless:

- The parking brake is engaged.
- The blade-control switch (PTO) is disengaged.
- The motion-control levers are in the NEUTRAL-LOCK position.

The safety-interlock system also is designed to shut off the engine when the traction controls are moved from the locked position with the parking brake engaged or if you rise from the seat when the PTO is engaged.

The hour meter has symbols to notify the user when the interlock component is in the correct position. When the component is in the correct position, a triangle lights up in the corresponding square.

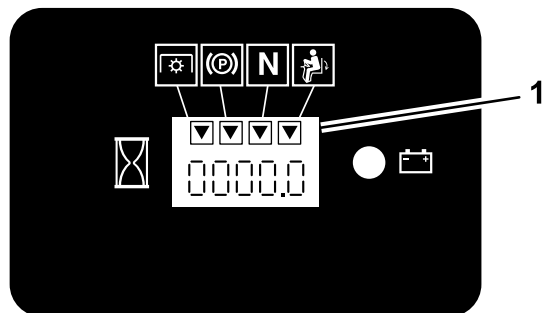

G009612

g009612

Figure 12

1. Triangles light up when the interlock components are in the correct position

Testing the Safety-Interlock System

Service Interval: Before each use or daily

Test the safety-interlock system before you use the machine each time. If the safety system does not operate as described below, have an Authorized Service Dealer repair the safety system immediately.

1. Sitting on the seat, engage the parking brake and move the blade-control switch (PTO) to the ON position. Try starting the engine; the engine should not start.
2. Sitting on the seat, engage the parking brake and move the blade-control switch (PTO) to the OFF position. Move either motion-control lever (out of the NEUTRAL-LOCK position). Try starting the engine; the engine should not start. Repeat for the other control lever.
3. Sitting on the seat, engage the parking brake, move the blade-control switch (PTO) to the OFF position, and move the motion-control levers to the NEUTRAL-LOCK position. Now start the engine. While the engine is running, disengage the parking brake, engage the blade-control switch (PTO), and rise slightly from the seat; the engine should shut off.
4. Sitting on the seat, engage the parking brake, move the blade-control switch (PTO) to the OFF position, and move the motion-control levers to the NEUTRAL-LOCK position. Now start the

engine. While the engine is running, center either motion control and move (forward or reverse); the engine should shut off. Repeat for other motion control.

5. Sitting on the seat, disengage the parking brake, move the blade-control switch (PTO) to the OFF position, and move the motion-control levers to the NEUTRAL-LOCK position. Try starting the engine; the engine should not start.

Positioning the Seat

The seat moves forward and backward. Position the seat where you have the best control of the machine and are most comfortable.

To adjust, move the lever sideways to unlock the seat ([Figure 13](#)).

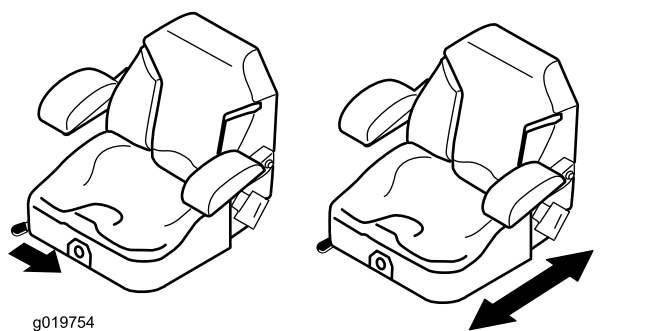

g019754

g019754

Figure 13

Unlatching the Seat

1. Move the seat to the most rearward position.
 - Note:** This prevents interference when you raise the seat.
2. Push the seat latch rearward to unlatch the seat.
3. Raise the seat up ([Figure 14](#)).

Note: This allows access to the machine under the seat.

Changing the Seat Suspension

The seat adjusts to provide a smooth and comfortable ride. Position the seat where you are most comfortable.

To adjust, turn the knob in front either direction to provide the best comfort (Figure 15).

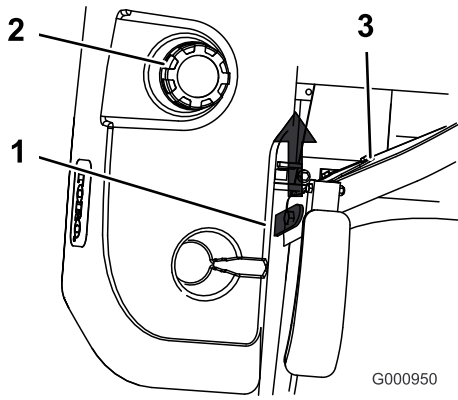

Figure 14

- 1. Seat latch
 - 2. Fuel cap
 - 3. Seat
-

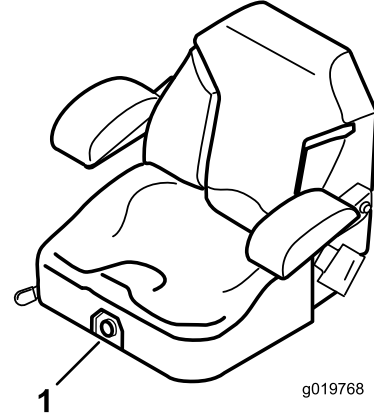

Figure 15

- 1. Seat-suspension knob
-

During Operation

During Operation Safety

General Safety

- The owner/operator can prevent and is responsible for accidents that may cause personal injury or property damage.
- Wear appropriate clothing, including eye protection; slip-resistant, substantial footwear; and hearing protection. Tie back long hair and do not wear jewelry.
- Do not operate the machine while ill, tired, or under the influence of alcohol or drugs.
- Never carry passengers on the machine and keep bystanders and pets away from the machine during operation.
- Operate the machine only in good visibility to avoid holes or hidden hazards.
- Avoid mowing on wet grass. Reduced traction could cause the machine to slide.
- Ensure that all drives are in neutral, the parking brake is engaged, and you are in the operating position before you start the engine.
- Keep your hands and feet away from the cutting units. Keep clear of the discharge opening at all times.
- Look behind and down before backing up to be sure of a clear path.
- Use care when approaching blind corners, shrubs, trees, or other objects that may obscure your vision.
- Do not mow near drop-offs, ditches, or embankments. The machine could suddenly roll over if a wheel goes over the edge or if the edge gives way.
- Stop the blades whenever you are not mowing.
- Stop the machine and inspect the blades after striking an object or if there is an abnormal vibration in the machine. Make all necessary repairs before resuming operation.
- Slow down and use caution when making turns and crossing roads and sidewalks with the machine. Always yield the right-of-way.
- Disengage the drive to the cutting unit and shut off the engine before adjusting the height of cut (unless you can adjust it from the operating position).
- Never run an engine in an area where exhaust gases are enclosed.

- Never leave a running machine unattended.
- Before leaving the operating position (including to empty the catchers or to unclog the chute), do the following:
 - Stop the machine on level ground.
 - Disengage the power take-off and lower the attachments.
 - Engage the parking brake.
 - Shut off the engine and remove the key.
 - Wait for all moving parts to stop.
- Do not operate the machine when there is the risk of lightning.
- Do not use the machine as a towing vehicle.
- Do not change the governor speed or overspeed the engine.
- Use accessories and attachments approved by Toro only.

Rollover Protection System (ROPS) Safety

- **Do not** remove the roll bar from the machine.
- Ensure that the seat belt is attached and that you can release it quickly in an emergency.
- Always wear your seat belt when the roll bar is up.
- Check carefully for overhead obstructions and do not contact them.
- Keep the roll bar in safe operating condition by thoroughly inspecting it periodically for damage and keeping all the mounting fasteners tight.
- Replace a damaged roll bar. Do not repair or alter it.

Slope Safety

- Slow down the machine and use extra care on hillsides. Travel up and down on hillsides. Turf conditions can affect the stability of the machine.
- Avoid turning the machine on slopes. If you must turn the machine, turn it slowly and gradually downhill, if possible.
- Do not turn the machine sharply. Use care when reversing the machine.
- Use extra care while operating the machine with attachments; they can affect the stability of the machine.

Operating the Parking Brake

Always engage the parking brake when you stop the machine or leave it unattended.

Engaging the Parking Brake

⚠ WARNING

The parking brake may not hold the machine parked on a slope and could cause personal injury or property damage.

Do not park on slopes unless the wheels are chocked or blocked.

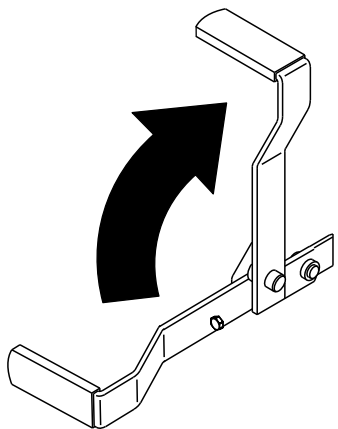

Figure 16

g187227

Disengaging the Parking Brake

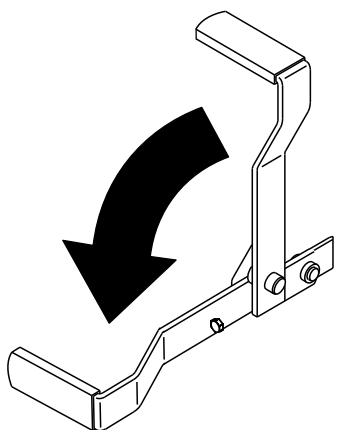

Figure 17

g187226

Operating the Mower Blade-Control Switch (PTO)

The blade-control switch (PTO) starts and stops the mower blades and any powered attachments.

Engaging the Blade-Control Switch (PTO)

Note: Engaging the blade-control switch (PTO) with the throttle position at half or less causes excessive wear to the drive belts.

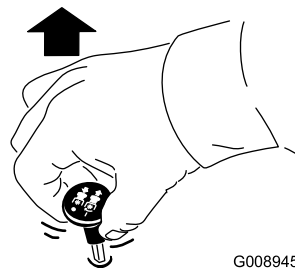

G008945

g008945

Figure 18

Disengaging the Blade-Control Switch (PTO)

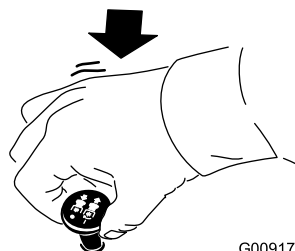

G009174

g009174

Figure 19

Operating the Throttle

You can move the throttle control between the FAST and SLOW positions (Figure 20).

Always use the FAST position when turning on the mower deck with the blade-control switch (PTO).

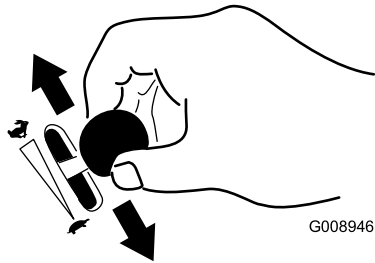

G008946

Figure 20

g008946

Operating the Ignition Switch

1. Turn the ignition key to the START position (Figure 21).

Note: When the engine starts, release the key.

Important: Do not engage the starter for more than 5 seconds at a time. If the engine fails to start, wait 15 seconds between attempts. Failure to follow these instructions can burn out the starter motor.

Note: You may need multiple attempts to start the engine when you start it the first time after the fuel system has been without fuel completely.

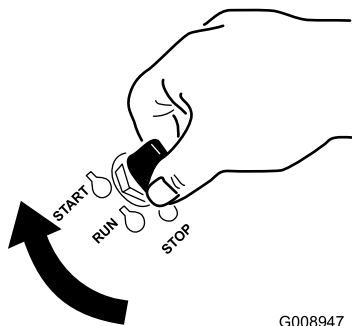

G008947

Figure 21

g008947

2. Turn the ignition key to the STOP position to shut off the engine.

Starting and Shutting Off the Engine

Starting the Engine in Normal Weather

Important: Use starting cycles of no more than 30 seconds per minute to avoid overheating the starter motor.

Note: Additional starting cycles may be required when starting the engine for the first time after the fuel system has been completely without fuel.

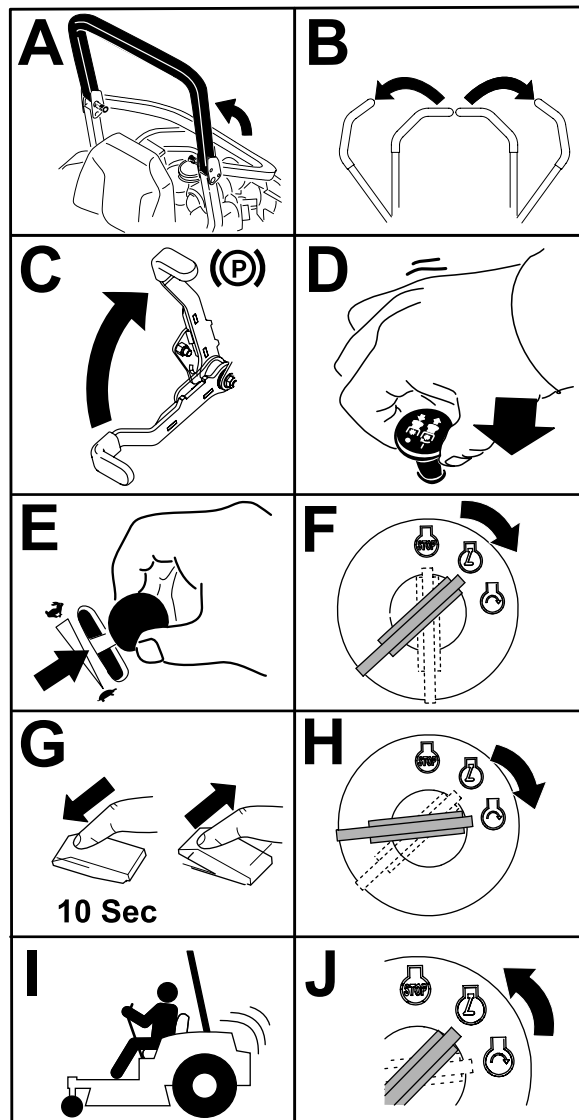

G032593

g032593

Figure 22

Starting the Engine in Cold Weather (Below 23°F or -5°C)

Use the correct engine oil for the starting temperature; refer to [Servicing the Engine Oil](#) (page 42).

Important: Use starting cycles of no more than 30 seconds per minute to avoid overheating the starter motor.

Note: Do not use fuel left over from the summer. Use only fresh winter-grade diesel fuel.

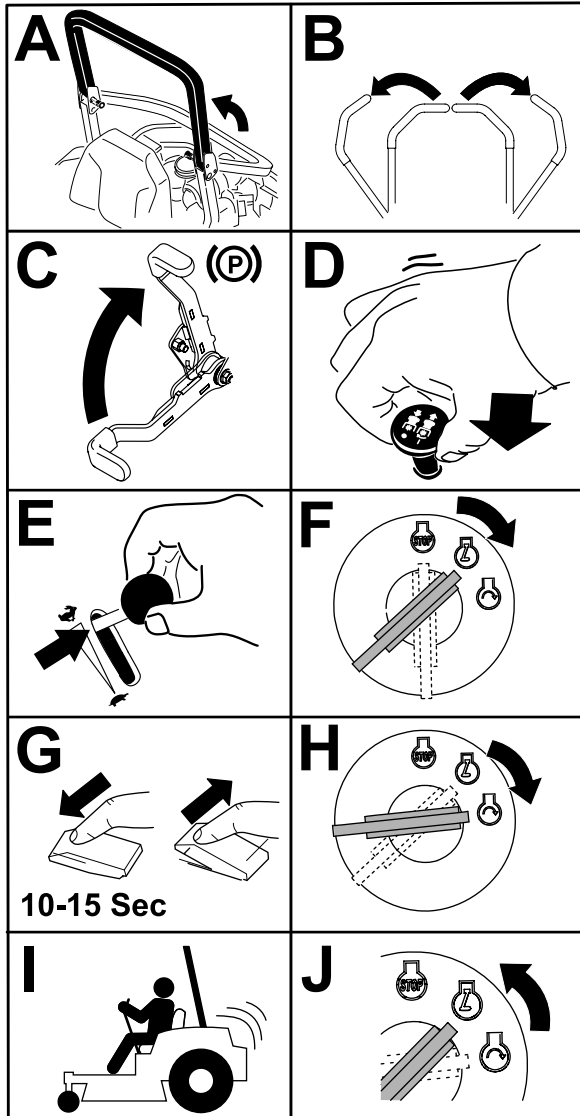

Figure 23

G032594
g032594

Shutting Off the Engine

⚠ CAUTION

Children or bystanders may be injured if they move or attempt to operate the tractor while it is unattended.

Always remove the ignition key and engage the parking brake when leaving the machine unattended, even if just for a few minutes.

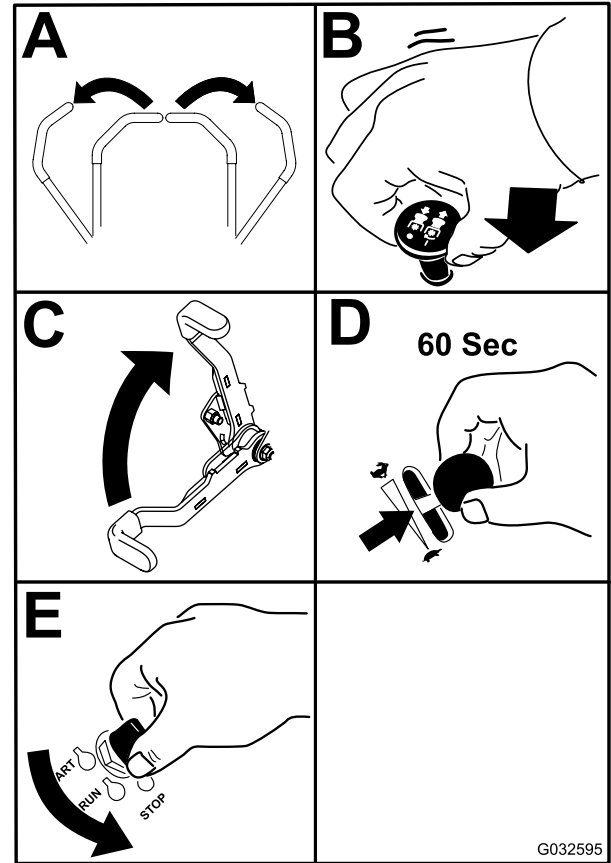

Figure 24

G032595
g032595

Important: Make sure that you close the fuel-shutoff valve before transporting or storing the machine, as fuel leakage may occur. Engage the parking brake before transporting the machine. Make sure that you remove the key as the fuel pump may run and cause the battery to lose charge.

Using the Motion-Control Levers

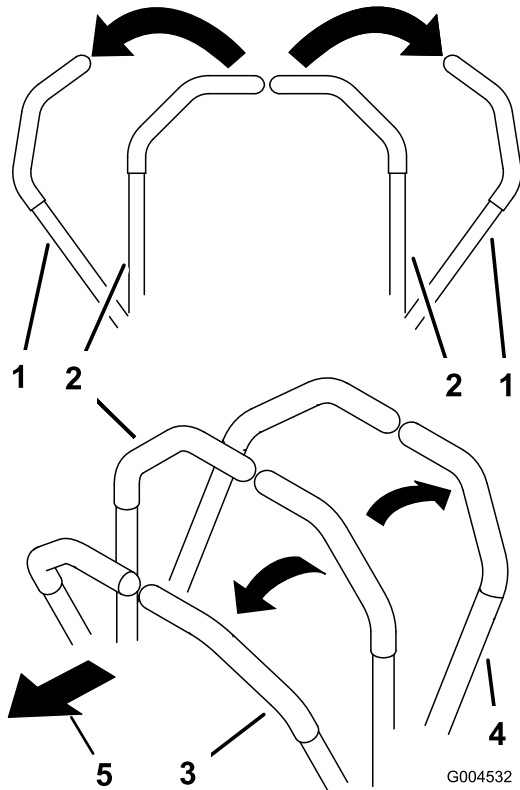

Figure 25

g004532

1. Motion-control lever—NEUTRAL-LOCK position
2. Center, unlocked position
3. Forward
4. Backward
5. Front of machine

⚠ CAUTION

Machine can spin very rapidly. Operator may lose control of machine and cause personal injury or damage to machine.

- Use caution when making turns.
- Slow the machine down before making sharp turns.

Driving the Machine

The drive wheels turn independently, powered by hydraulic motors on each axle. You can turn 1 side in reverse while you turn the other forward, causing the machine to spin rather than turn. This greatly improves the machine maneuverability but may require sometime for you to adapt to how it moves.

The throttle control regulates the engine speed as measured in rpm (revolutions per minute). Place the throttle control in the FAST position for best performance. Always operate in the full throttle position when mowing.

Driving Forward

Note: The engine stops when you move the traction-control with the parking brake engaged.

To stop, pull the motion-control levers to the NEUTRAL position.

1. Disengage the parking brake; refer to [Disengaging the Parking Brake \(page 24\)](#).
2. Move the levers to the center, unlocked position.
3. To go forward, slowly push the motion-control levers forward ([Figure 26](#)).

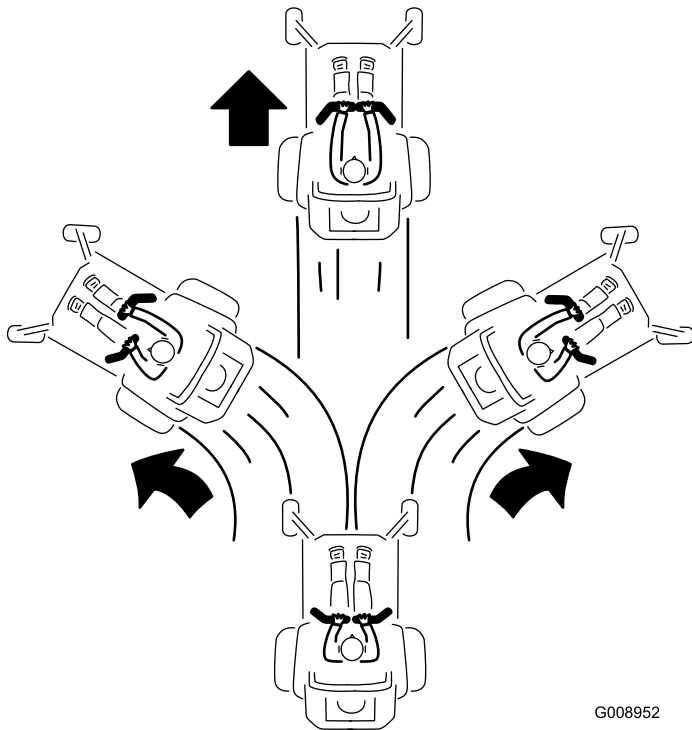
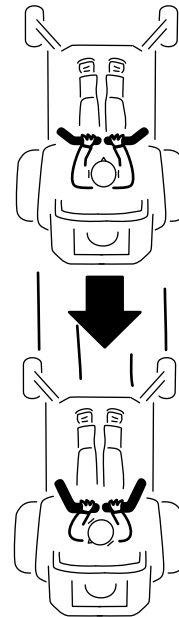

Figure 26

G008952
g008952

Driving Backward

1. Move the levers to the center, unlocked position.
2. To go backward, slowly pull the motion-control levers rearward ([Figure 27](#)).



G008953

g008953

Figure 27

Stopping the Machine

To stop the machine, move the traction control levers to the NEUTRAL position and then to the NEUTRAL-LOCK position, disengage the blade-control switch (PTO), and turn the ignition key to the OFF position.

Engage the parking brake when you leave the machine. Remember to remove the key from the ignition switch.

⚠ CAUTION

Children or bystanders may be injured if they move or attempt to operate the machine while it is unattended.

Always remove the ignition key and engage the parking brake when leaving the machine unattended, even if just for a few minutes.

Using the Side Discharge

The mower has a hinged grass deflector that disperses clippings to the side and down toward the turf.

⚠ DANGER

Without a grass deflector, discharge cover, or a complete grass-catcher assembly mounted in place, you and others are exposed to blade contact and thrown debris. Contact with rotating mower blade(s) and thrown debris will cause injury or death.

- Never remove the grass deflector from the mower because the grass deflector routes material down toward the turf. If the grass deflector is ever damaged, replace it immediately.
- Never put your hands or feet under the mower.
- Never try to clear the discharge area or mower blades unless you move the blade-control switch (PTO) to the OFF position, rotate the ignition key to the OFF position, and remove the key.
- Make sure that the grass deflector is in the down position.

Adjusting the Height of Cut

Adjust the height of cut from 38 to 127 mm (1-1/2 to 5 inches) in 6 mm (1/4 inch) increments by moving the clevis pin into different hole locations.

1. Raise the height-of-cut lever to the TRANSPORT position (also the 127 mm (5 inches) cutting-height position) (Figure 28).

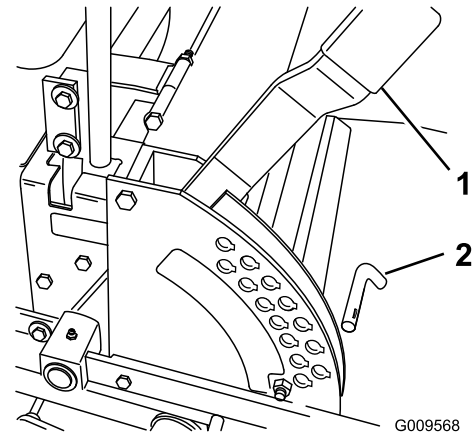

Figure 28

1. Height-of-cut lever

2. Pin

2. To adjust, remove the pin from the height-of-cut bracket (Figure 28).
3. Select a hole in the height-of-cut bracket corresponding to the height of cut desired, and insert the pin (Figure 28).
4. Move the lever to the selected height.

Adjusting the Anti-Scalp Rollers

Whenever you change the height of cut, it is recommended to adjust the height of the anti-scalp rollers.

1. Disengage the blade-control switch (PTO), move the motion-control levers to the NEUTRAL-LOCK position, and engage the parking brake.
2. Shut off the engine, remove the key, and wait for all moving parts to stop before leaving the operating position.
3. Adjust the anti-scalp rollers as shown in [Figure 29](#), [Figure 30](#), and [Figure 31](#).

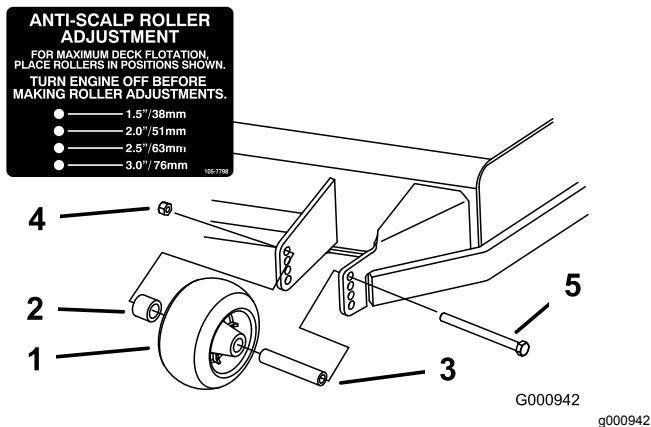

Figure 29

- | | |
|----------------------|---------------|
| 1. Anti-scalp roller | 4. Flange nut |
| 2. Spacer | 5. Bolt |
| 3. Bushing | |

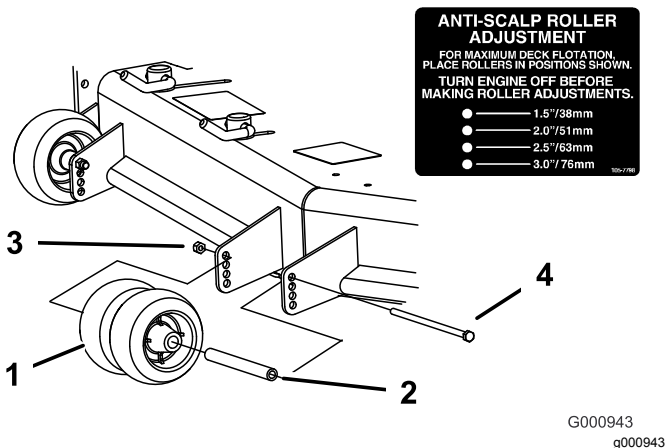

Figure 30

- | | |
|----------------------|---------------|
| 1. Anti-scalp roller | 3. Flange nut |
| 2. Bushing | 4. Bolt |

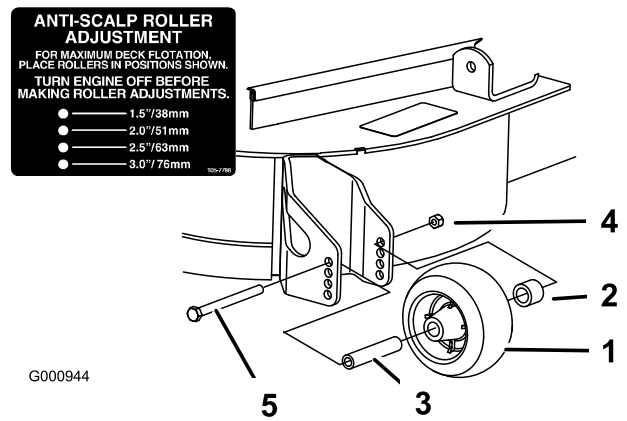

Figure 31

- | | |
|----------------------|---------------|
| 1. Anti-scalp roller | 4. Flange nut |
| 2. Spacer | 5. Bolt |
| 3. Bushing | |

Adjusting the Flow Baffle Cam Locks

This procedure is applicable only to machines with the flow-baffle locks. Certain models have nuts and bolts in place of the flow-baffle locks and can be adjusted the same.

You can adjust the mower-discharge flow for different types of mowing conditions. Position the cam locks and baffle to give the best quality of cut.

1. Disengage the blade-control switch (PTO), move the motion-control levers to the NEUTRAL-LOCK position, and engage the parking brake.
2. Shut off the engine, remove the key, and wait for all moving parts to stop before leaving the operating position.
3. To adjust the cam locks, swing the lever up to loosen the cam lock ([Figure 32](#)).
4. Adjust the baffle and cam locks in the slots to the desired discharge flow.
5. Swing the lever back over to tighten the baffle and cam locks ([Figure 32](#)).
6. If the cam locks do not lock the baffle into place or it is too tight, loosen the lever and then rotate the cam lock.

Note: Adjust the cam lock until the desired locking pressure is achieved.

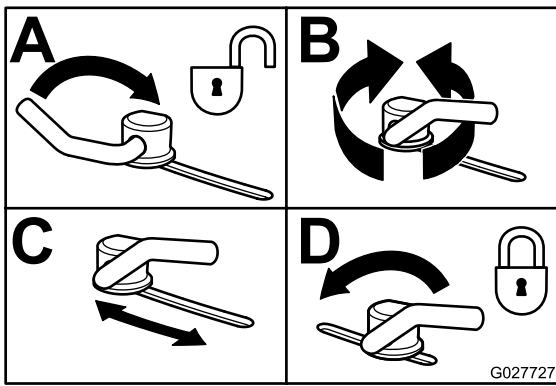

Figure 32

g027727

Positioning the Flow Baffle

The following figures are only recommendations for use. Adjustments vary by grass type, moisture content, and the height of the grass.

Note: If the engine power draws down and the mower ground speed is the same, open up the baffle.

Position A

This is the full rear position. The suggested use for this position is as follows:

- Short, light grass mowing conditions
- Dry conditions
- Smaller grass clippings
- Propels grass clippings farther away from the mower

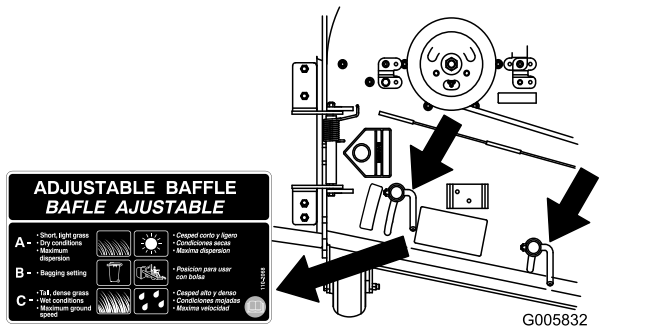

Figure 33

G005832

g005832

Position B

Use this position when bagging. Always align it with the blower opening.

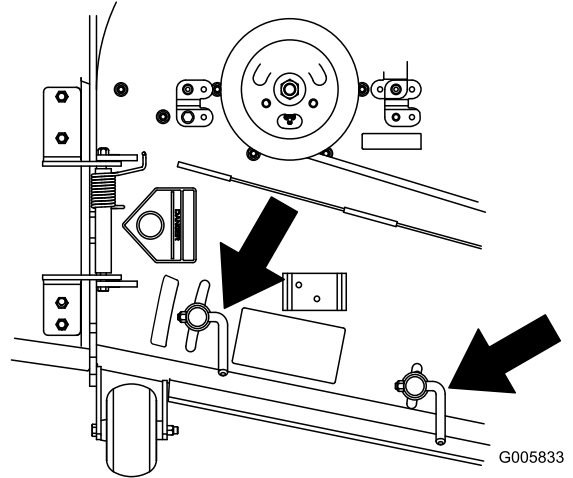

Figure 34

G005833

g005833

Position C

This is the full open position. The suggested use for this position is as follows:

- Tall, dense grass mowing conditions
- Wet conditions
- Lowers the engine-power consumption
- Allows increased ground speed in heavy conditions

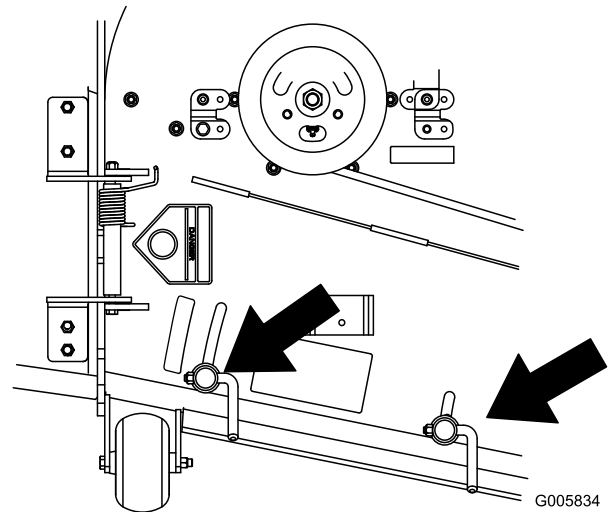

Figure 35

G005834

g005834

Operating with the Overheat Sensor

This machine has a sensor that turns off the mower deck when the engine overheats. When the engine overheats, the audible alarm and light alarm turns on along with the mower deck turning off.

If the mower deck turns off automatically because of overheating, you will be able to drive the machine to a safe area or to a truck or trailer.

If the machine overheats, ensure that the area around the engine and radiator is clear of any debris. Shut off the engine and allow it to cool before you engage the mower deck. If the engine continues to overheat, take your machine to an Authorized Service Dealer.

Operating Tips

Using the Fast Throttle Setting

For best mowing and maximum air circulation, operate the engine at the FAST position. Air is required to thoroughly cut grass clippings, so do not set the height-of-cut so low as to totally surround the mower in uncut grass. Always try to have 1 side of the mower free from uncut grass, which allows air to be drawn into the mower.

Cutting a Lawn for the First Time

Cut grass slightly longer than normal to ensure that the cutting height of the mower does not scalp any uneven ground. However, the cutting height used in the past is generally the best one to use. When cutting grass longer than 15 cm (6 inches) tall, you may want to cut the lawn twice to ensure an acceptable quality of cut.

Cutting a Third of the Grass Blade

It is best to cut only about a third of the grass blade. Cutting more than that is not recommended unless grass is sparse, or it is late fall when grass grows more slowly.

Alternating the Mowing Direction

Alternate the mowing direction to keep the grass standing straight. This also helps disperse clippings which enhances decomposition and fertilization.

Mowing at Correct Intervals

Grass grows at different rates at different times of the year. To maintain the same cutting height, mow

more often in early spring. As the grass growth rate slows in mid summer, mow less frequently. If you cannot mow for an extended period, first mow at a high cutting height, then mow again 2 days later at a lower height setting.

Using a Slower Cutting Speed

To improve cut quality, use a slower ground speed in certain conditions.

Avoiding Cutting Too Low

When mowing uneven turf, raise the cutting height to avoid scalping the turf.

Stopping the Machine

If you must stop the forward motion of the machine while mowing, a clump of grass clippings may drop onto your lawn. To avoid this, move onto a previously cut area with the blades engaged or you can disengage the mower deck while moving forward.

Keeping the Underside of the Mower Clean

Clean clippings and dirt from the underside of the mower after each use. If grass and dirt build up inside the mower, cutting quality will eventually become unsatisfactory.

Maintaining the Blade(s)

Maintain a sharp blade throughout the cutting season because a sharp blade cuts cleanly without tearing or shredding the grass blades. Tearing and shredding turns grass brown at the edges, which slows growth and increases the chance of disease. Check the mower blades after each use for sharpness, and for any wear or damage. File down any nicks and sharpen the blades as necessary. If a blade is damaged or worn, replace it immediately with a genuine Toro replacement blade.

After Operation

After Operation Safety

General Safety

- Clean grass and debris from the cutting units, mufflers, and engine compartment to help prevent fires. Clean up oil or fuel spills.
- Shut off the fuel before storing or transporting the machine.
- Disengage the drive to the attachment whenever you are transporting or not using the machine.
- Use full-width ramps for loading the machine into a trailer or truck.
- Tie the machine down securely using straps, chains, cable, or ropes. Both front and rear straps should be directed down and outward from the machine.
- Allow the engine to cool before storing the machine in any enclosure.
- Shut off the fuel before storing or transporting the machine.
- Never store the machine or fuel container where there is an open flame, spark, or pilot light, such as on a water heater or on other appliances.

Using the Fuel-Shutoff Valve

The fuel-shutoff valve is located under the seat. Move the seat forward to access it.

Close the fuel-shutoff valve for transport, maintenance, and storage.

Ensure that the fuel-shutoff valve is open when starting the engine.

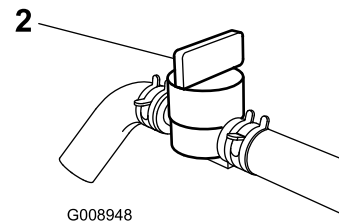
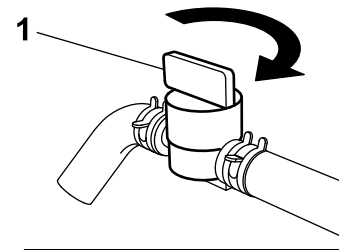

G008948

g008948

Figure 36

1. ON position

2. OFF position

Pushing the Machine by Hand

Important: Always push the machine by hand. Never tow the machine because hydraulic damage may occur.

Pushing the Machine

1. Disengage the blade-control switch (PTO), turn the ignition key to the OFF position, move the levers to NEUTRAL-LOCK position, engage the parking brake, and remove the key.
2. Rotate the bypass valves counterclockwise 1 turn to push (Figure 37).

Note: This allows hydraulic fluid to bypass the pump enabling the wheels to turn.

Important: Do not rotate bypass valves more than 1 turn. This prevents valves from coming out of the body and causing fluid to run out.

3. Disengage the parking brake before pushing.

Changing to Machine Operation

Rotate the bypass valves clockwise 1 turn to operate machine (Figure 37).

Note: Do not over-tighten the bypass valves.

Important: The machine does not drive unless bypass valves are turned in.

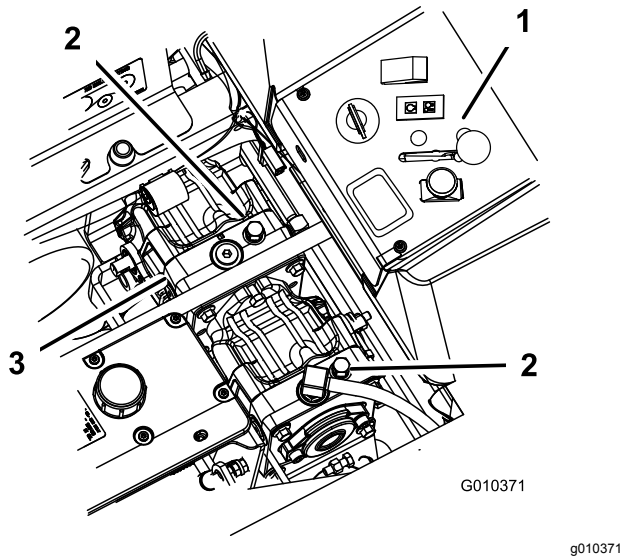

Figure 37

1. Side console controls
2. Bypass valve
3. Hydraulic pumps

Transporting the Machine

Use a heavy-duty trailer or truck to transport the machine. Ensure that the trailer or truck has all necessary brakes, lighting, and marking as required by law. Please carefully read all the safety instructions. Knowing this information could help you, your family, pets, or bystanders avoid injury.

To transport the machine:

- Lock the brake and block the wheels.
- Securely fasten the machine to the trailer or truck with straps, chains, cable, or ropes.
- Secure a trailer to the towing vehicle with safety chains.

⚠ WARNING

Driving on the street or roadway without turn signals, lights, reflective markings, or a slow moving vehicle emblem is dangerous and can lead to accidents causing personal injury.

Do not drive machine on a public street or roadway.

Loading the Machine

Use extreme caution when loading or the unloading machine onto a trailer or a truck. Use a full-width ramp that is wider than the machine for this procedure. Back the machine up the ramp and drive it forward down the ramp (Figure 38).

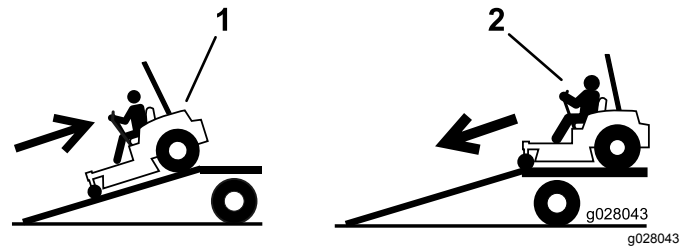

Figure 38

1. Back the machine up the ramp.
2. Drive the machine forward down the ramp.

⚠ WARNING

Loading a machine onto a trailer or truck increases the possibility of tip-over and could cause serious injury or death.

- Use extreme caution when operating a machine on a ramp.
- Ensure that the roll bar is in the up position and use the seat belt when loading or unloading the machine. Ensure that the roll bar will clear the top of an enclosed trailer.
- Use only a full-width ramp; do not use individual ramps for each side of the machine.
- Do not exceed a 15-degree angle between the ramp and the ground or between the ramp and the trailer or truck.
- Ensure that the length of ramp is at least 4 times as long as the height of the trailer or truck bed to the ground. This ensures that the ramp angle does not exceed 15 degrees on flat ground.
- Back up ramps and drive forward down ramps.
- Avoid sudden acceleration or deceleration while driving the machine on a ramp as this could cause a loss of control or a tip-over situation.

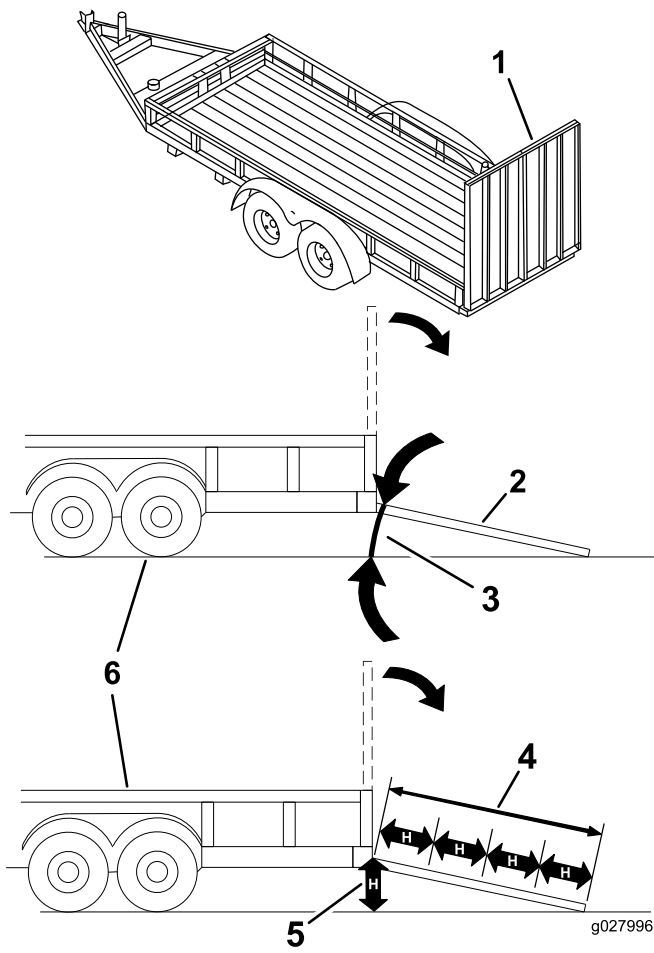

g027996

g027996

Figure 39

- | | |
|---|---|
| 1. Full-width ramp in stowed position | 4. Ramp is at least 4 times as long as the height of the trailer or truck bed to the ground |
| 2. Side view of full-width ramp in loading position | 5. H= height of the trailer or truck bed to the ground |
| 3. Not greater than 15 degrees | 6. Trailer |

Maintenance

Recommended Maintenance Schedule(s)

Maintenance Service Interval	Maintenance Procedure
After the first 8 hours	<ul style="list-style-type: none"> • Check the engine cooling system level. • Adjust the mower belt tension (for 72-inch mowers only). • Check the hydraulic fluid.
After the first 25 hours	<ul style="list-style-type: none"> • Change the hydraulic filter.
After the first 50 hours	<ul style="list-style-type: none"> • Replace the engine oil. • Change the engine-oil filter. • Change the engine oil.
After the first 100 hours	<ul style="list-style-type: none"> • Check the wheel-hub slotted nut. • Change the gearbox oil.
Before each use or daily	<ul style="list-style-type: none"> • Check the safety system. • Check the engine-oil level. • Check the engine cooling system level. • Clean the engine-oil cooler. • Inspect the blades. • Clean the mower deck.
Every 25 hours	<ul style="list-style-type: none"> • Grease the mower deck and spindles. • Grease the mower belt idler arm. • Grease the pump belt idler arm. • Grease the PTO-drive belt idler arm. • Grease the brake lever. • Check the hydraulic fluid.
Every 40 hours	<ul style="list-style-type: none"> • Drain the water separator.
Every 50 hours	<ul style="list-style-type: none"> • Check the tire pressure • Check the PTO-drive belt. • Check the pump drive belt. • Check the alternator belt.
Every 100 hours	<ul style="list-style-type: none"> • Replace the engine oil. • Change the engine oil. • Check the gearbox-oil level. • Check the engine cooling system hoses. • Inspect the belts for cracks and wear. • Check the hydraulic hoses.
Every 150 hours	<ul style="list-style-type: none"> • Add light oil or spray lubrication to the machine (refer to lubrication).
Every 200 hours	<ul style="list-style-type: none"> • Change the engine-oil filter. • Grease the brake pivot.
Every 250 hours	<ul style="list-style-type: none"> • Check and/or replace the air filter (more often in dirty or dusty conditions). • Change the hydraulic filter and hydraulic fluid when using Mobil® 1 fluid.
Every 400 hours	<ul style="list-style-type: none"> • Replace the fuel filter (more often in dirty or dusty conditions).

Maintenance Service Interval	Maintenance Procedure
Every 500 hours	<ul style="list-style-type: none"> • Check the wheel-hub slotted nut. • Adjust the caster-pivot bearing. • Adjust the electric clutch. • Change the hydraulic filter and hydraulic fluid when using Toro® HYPR-OIL™ 500 hydraulic fluid.
Yearly	<ul style="list-style-type: none"> • Grease the front caster pivots (more often in dirty or dusty conditions). • Lubricate the caster-wheel hubs. • Change the gearbox oil. • Change the engine coolant.

Important: Refer to your engine operator's manual for additional maintenance procedures.

⚠ CAUTION

If you leave the key in the ignition switch, someone could accidentally start the engine and seriously injure you or other bystanders.

Remove the key from the ignition before you perform any maintenance.

Pre-Maintenance Procedures

Maintenance and Storage

- Before repairing the machine do the following:
 - Disengage the drives.
 - Engage the parking brake.
 - Shut off the engine and remove the key.
- Park the machine on a level surface.
- Clean grass and debris from the cutting unit, drives, mufflers, and engine to help prevent fires.
- Clean up oil or fuel spills.
- Let the engine cool before storing the machine.
- Do not store the machine or fuel near flames or drain the fuel indoors.
- Do not allow untrained personnel to service the machine.
- Use jack stands to support the machine and/or components when required.
- Carefully release pressure from components with stored energy.
- Disconnect the battery before making any repairs. Disconnect the negative terminal first and the positive terminal last. Connect the positive terminal first and negative last.
- Use care when checking the blades. Wrap the blade(s) or wear thickly padded gloves, and use caution when servicing them. Only replace blades; do not straighten or weld them.
- Keep your hands and feet away from moving parts. If possible, do not make adjustments with the engine running.
- Keep all parts in good working condition and all hardware tightened, especially the blade-attachment bolts. Replace all worn or damaged decals.
- Never interfere with the intended function of a safety device or reduce the protection provided by a safety device. Check their proper operation regularly.
- To ensure optimum performance and continued safety certification of the machine, use only genuine Toro replacement parts and accessories. Replacement parts and accessories made by other manufacturers could be dangerous, and such use could void the product warranty.
- Check the parking brake operation frequently. Adjust and service as required.

Lubrication

Lubricate the machine when shown on the Check Service Reference Aid decal (Figure 40). Grease more frequently when operating conditions are extremely dusty or sandy.

Grease Type: No. 2 lithium or molydenum grease

Greasing the Machine

1. Disengage the PTO, move the motion-control levers to the NEUTRAL-LOCK position, and engage the parking brake.
2. Shut off the engine, remove the key, and wait for all moving parts to stop before leaving the operating position.
3. Clean the grease fittings with a rag.

Note: Make sure that you scrape any paint off the front of the fitting(s).

4. Connect a grease gun to the fitting and pump grease into the fittings until grease begins to ooze out of the bearings.
5. Wipe up any excess grease.

Greasing the Front Caster Pivots

Service Interval: Yearly (more often in dirty or dusty conditions).

1. Remove the dust cap and adjust the caster pivots and keep the dust cap off until greasing is done; refer to [Adjusting the Caster-Pivot Bearing \(page 51\)](#).
2. Remove the hex plug.
3. Thread a grease fitting into the hole.
4. Pump grease into the fitting until it oozes out around the top bearing.
5. Remove the grease fitting from the hole. Install the hex plug and cap.

Adding Grease

Lubricate the grease fittings as shown on the Check Service Reference Aid decal (Figure 40).

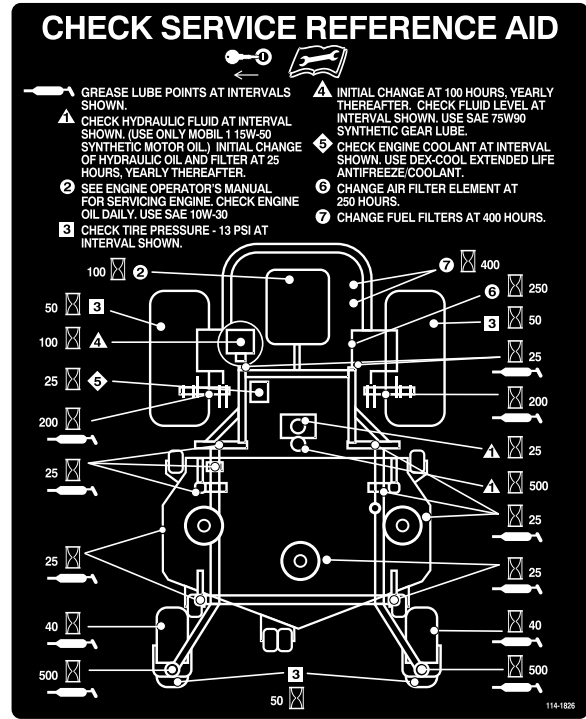

G005930

g005930

Figure 40

Adding Light Oil or Spray Lubrication

Service Interval: Every 150 hours

Lubricate the machine in the following areas with spray type lubricant or light oil.

- Seat-switch actuator
- Brake-handle pivot
- Brake-rod bushings
- Motion control bronze bushings

Greasing the Mower Deck and Belt Idlers

Service Interval: Every 25 hours—Grease the mower deck and spindles.

Grease with No. 2 lithium or molybdenum grease.

Important: Make sure that the cutting-unit spindles are full of grease weekly.

1. Disengage the blade-control switch (PTO), move the motion-control levers to the NEUTRAL-LOCK position, and engage the parking brake.
2. Shut off the engine, remove the key, and wait for all moving parts to stop before leaving the operating position.
3. Remove the belt covers.
4. Grease the fittings on the 3 spindle bearings (Figure 42).
5. Grease the idler arm on the mower deck (Figure 41 or Figure 42).
6. Grease the fittings on the push arms (Figure 41 or Figure 42).

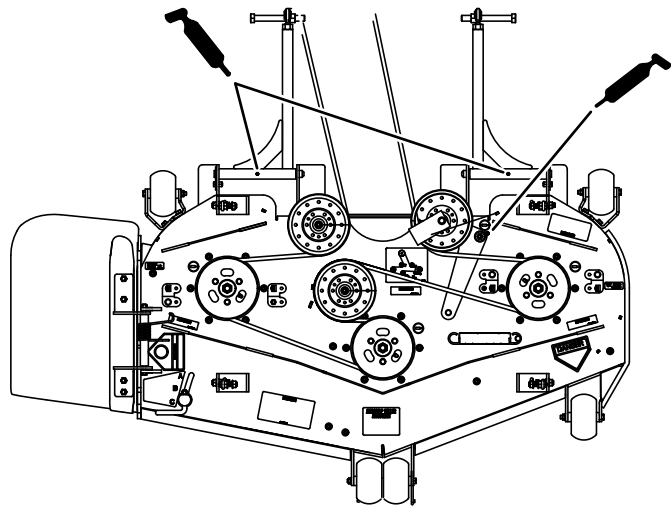

g187362

Figure 41

52-inch and 60-inch Mower Decks

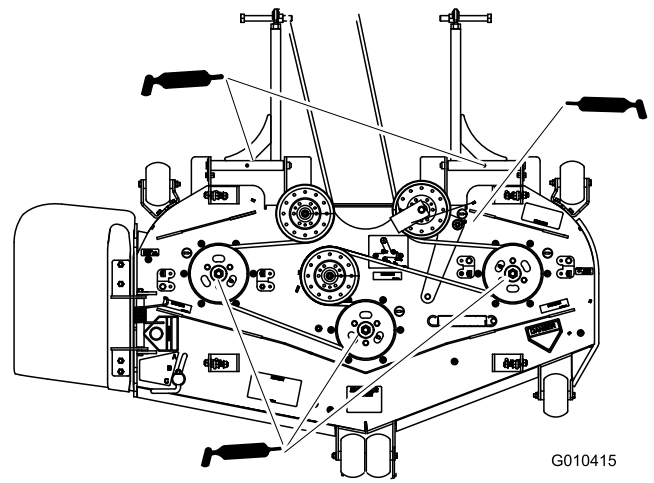

G010415

g010415

Figure 42

72-inch Mower Deck

7. Grease the PTO-drive belt idler arm (Figure 43).
8. Grease the pump belt idler arm (Figure 43).

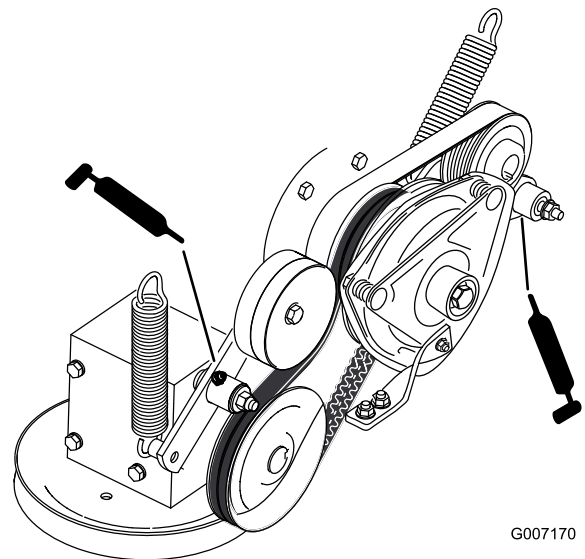

G007170

g007170

Figure 43

Lubricating the Caster-Wheel Hubs

Service Interval: Yearly

1. Shut off the engine, wait for all moving parts to stop, remove the key, and engage the parking brake.

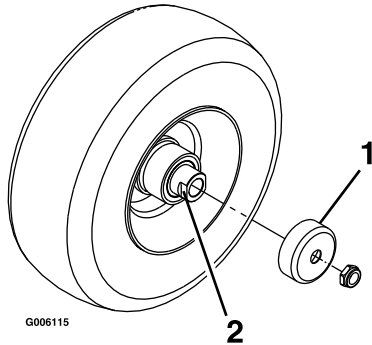

Figure 44

G006115

1. Seal guard
2. Spacer nut with wrench flats

2. Raise the mower for access.
3. Remove the caster wheel from the caster forks.
4. Remove the seal guards from the wheel hub.
5. Remove a spacer nut from the axle assembly in the caster wheel.

Note: Thread-locking adhesive has been applied to lock the spacer nuts to the axle.

6. Remove the axle (with the other spacer nut still assembled to it) from the wheel assembly.
7. Pry out seals and inspect bearings for wear or damage and replace if necessary.
8. Pack the bearings with a general-purpose grease.
9. Insert 1 bearing and 1 new seal into the wheel.

Note: Replace the seals.

10. If the axle assembly is missing both spacer nuts, apply a thread-locking adhesive to 1 spacer nut and thread it onto the axle with the wrench flats facing outward.

Note: Do not thread the spacer nut all of the way onto the end of the axle. Leave approximately 3 mm (1/8 inch) from the outer surface of the spacer nut to the end of the axle inside the nut.

11. Insert the assembled nut and axle into the wheel on the side of the wheel with the new seal and bearing.

12. With the open end of the wheel facing up, fill the area inside the wheel around the axle full of general-purpose grease.
13. Insert the second bearing and new seal into the wheel.
14. Apply a thread-locking adhesive to the second spacer nut, and thread it onto the axle with the wrench flats facing outward.
15. Torque the nut to 8 to 9 N·m (75 to 80 in-lb), loosen, then torque to 2 to 3 N·m (20 to 25 in-lb).
16. Install the seal guards over the wheel hub, and insert the wheel into the caster fork.
17. Install the caster bolt and tighten the nut fully.

Important: To prevent seal and bearing damage, check the bearing adjustment often. Spin the caster tire. The tire should not spin freely (more than 1 or 2 revolutions) or have any side play. If the wheel spins freely, adjust the torque on the spacer nut until there is a slight amount of drag. Apply another layer of thread-locking adhesive.

Engine Maintenance

⚠ WARNING

Contact with hot surfaces may cause personal injury.

Keep your hands, feet, face, clothing, and other body parts away from the muffler and other hot surfaces.

Engine Safety

Shut off the engine before checking the oil or adding oil to the crankcase.

Servicing the Air Cleaner

Note: Check the filters more frequently if operating conditions are extremely dusty or sandy.

Removing the Air Filter

Service Interval: Every 250 hours (more often in dirty or dusty conditions).

1. Disengage the blade-control switch (PTO), move the motion-control levers to the NEUTRAL-LOCK position, and engage the parking brake.
2. Shut off the engine, remove the key, and wait for all moving parts to stop before leaving the operating position.
3. Release the latches on the air cleaner and pull the air-cleaner cover off the air-cleaner body (Figure 45).
4. Clean the inside of the air-cleaner cover with compressed air.
5. Gently slide the filter out of the air-cleaner body (Figure 45).

Note: Avoid knocking the filter into the side of the body.

6. Inspect the filter for damage by looking into the filter while shining a bright light on the outside of the filter.

Note: Holes in the filter appear as bright spots. If the filter is damaged, discard it.

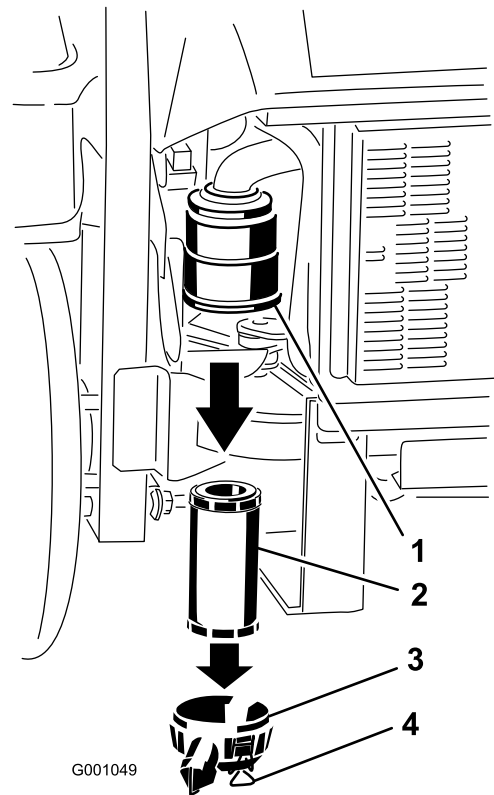

Figure 45

- | | |
|--------------------|----------------------|
| 1. Air-filter body | 3. Air-cleaner cover |
| 2. Air filter | 4. Latches |

Installing the Air Filter

1. If installing a new filter, check the filter for shipping damage. Do not use a damaged filter.
2. Carefully slide the filter into the filter body (Figure 46).

Note: Ensure that it is fully seated by pushing on the outer rim of the filter while installing it.

Important: Do not press on the soft inside area of the filter.

3. Install the air-cleaner cover and secure the latches (Figure 46).

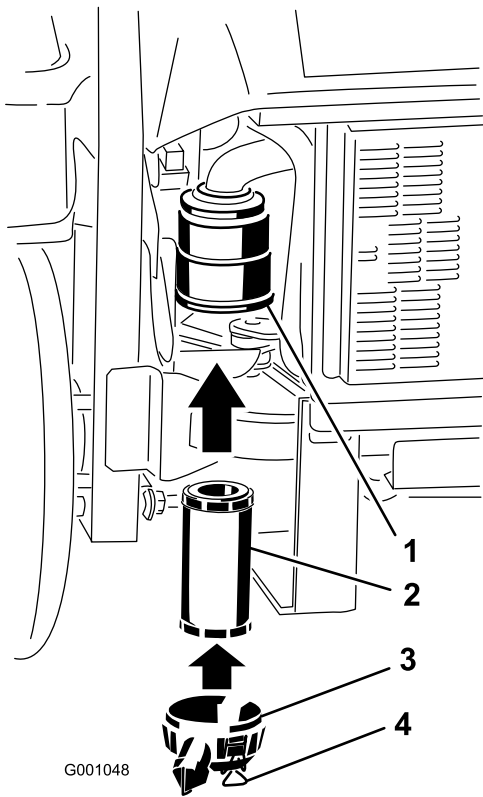

G001048

Figure 46

- | | |
|--------------------|----------------------|
| 1. Air-filter body | 3. Air-cleaner cover |
| 2. Air filter | 4. Latches |

g001048

Preparing to Service the Engine Oil

Important: The fasteners for the front engine panel are designed to remain on the machine after cover removal. Loosen all of the fasteners a few turns so that the panel is loose but still attached, then go back and loosen them until the panel comes free. This prevents you from accidentally stripping the bolts free of the retainers.

Tilt the seat forward, loosen the bolts holding the front engine panel and remove it (Figure 48).

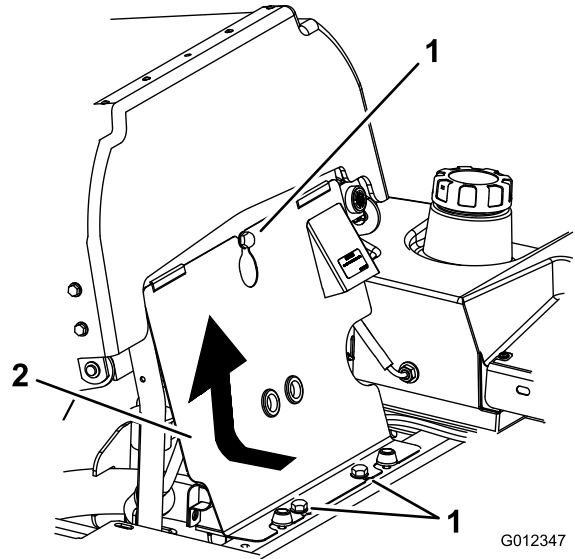

G012347

g012347

Figure 48

- | | |
|---------|-----------------------|
| 1. Bolt | 2. Front engine panel |
|---------|-----------------------|

Servicing the Engine Oil

Oil Type: High-quality detergent oil classified API Service CD or higher for diesel engines. Do not use special additives with recommended oils.

Crankcase Capacity: 3.7 L (3.9 US qt)

Viscosity: See the table below.

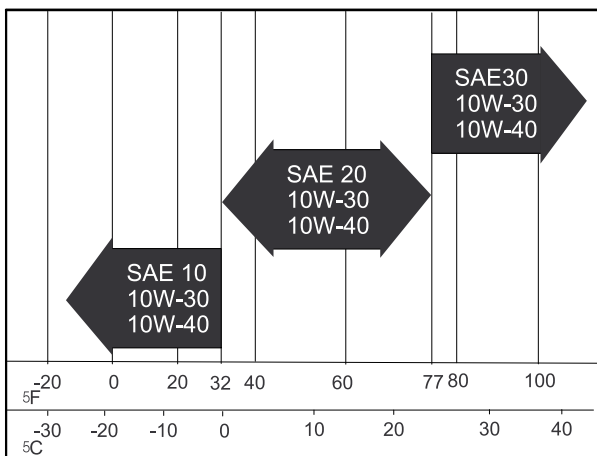

G001061

g001061

Figure 47

Checking the Engine-Oil Level

Service Interval: Before each use or daily

Note: Check the oil when the engine is cold.

1. Disengage the blade-control switch (PTO), move the motion-control levers to the NEUTRAL-LOCK position, and engage the parking brake.
2. Shut off the engine, remove the key, and wait for all moving parts to stop before leaving the operating position.
3. Check the engine-oil level (Figure 49).

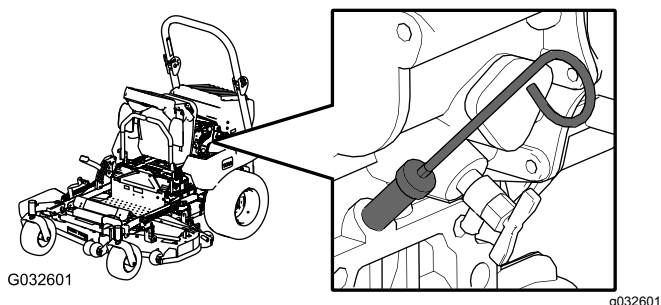

Important: Add the oil very slowly and do not block the opening of the filler hole (Figure 40). If you add oil too fast or block the hole, the oil could back up and foul the air intakes, causing engine damage.

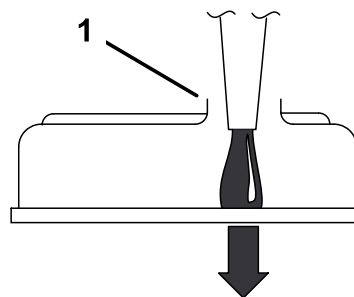

G000955

g000955

Figure 50

1. Note the clearance left in the filler opening.

Draining the Engine Oil

Service Interval: After the first 50 hours

Every 100 hours

1. Start the engine and let it run for 5 minutes.

Note: This warms the oil so it drains better.

2. Park the machine on a level surface, disengage the blade-control switch (PTO), move the motion-control levers to the NEUTRAL-LOCK position, and engage the parking brake.
3. Shut off the engine, remove the key, and wait for all moving parts to stop before leaving the operating position.

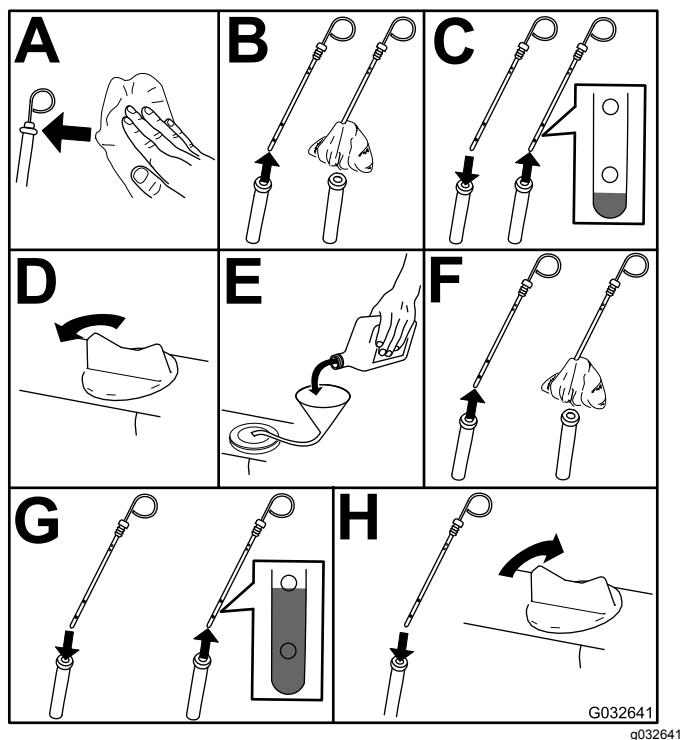
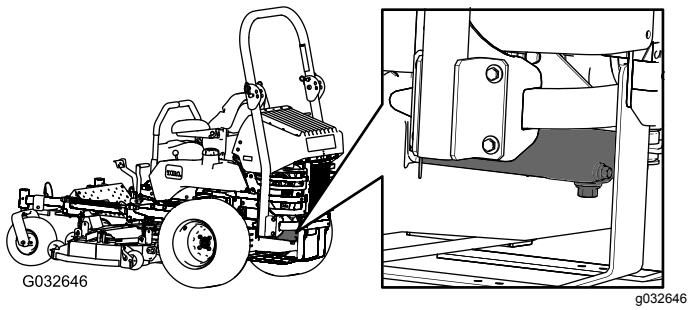

Figure 49

4. Start the engine, run it at idle for 5 minutes, shut off the engine, wait for 3 minutes, and then check the engine-oil level. If needed, add oil up to the FULL mark on the dipstick.

Important: Be sure to keep the engine-oil level between the upper and lower limits on the oil gauge. Engine failure may occur as a result.



Changing the Engine-Oil Filter

Service Interval: After the first 50 hours

Every 200 hours

1. Drain the oil from the engine; refer to [Draining the Engine Oil](#) (page 43).
2. Change the engine-oil filter ([Figure 52](#)).

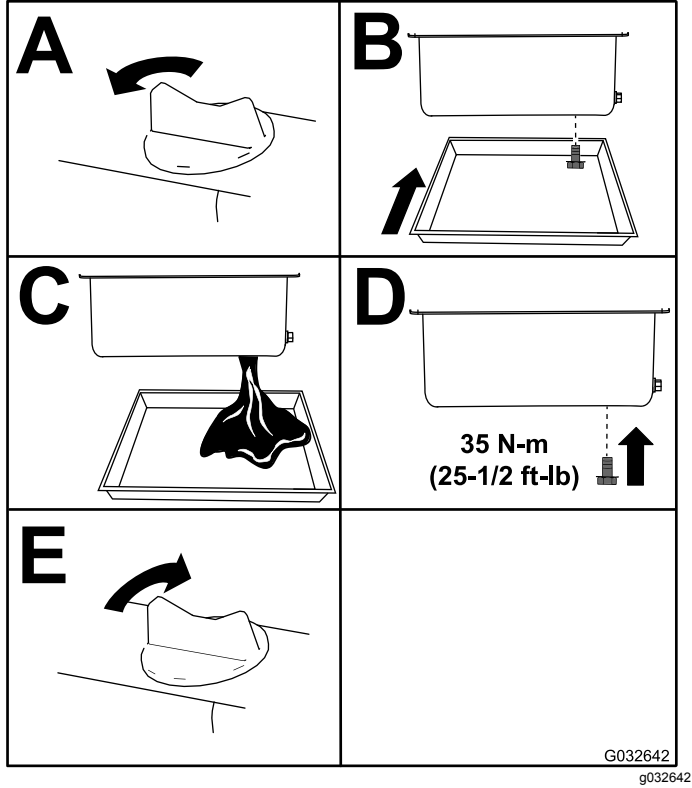
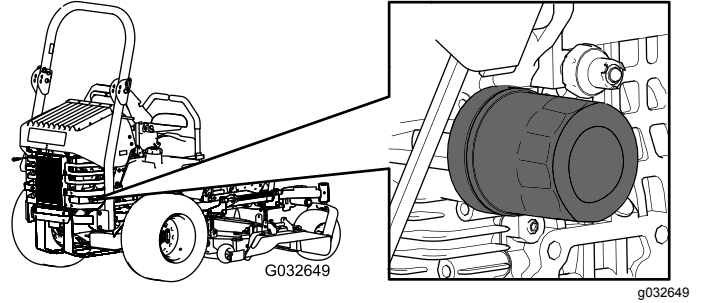

Figure 51

Note: Dispose of the used oil at a recycling center.

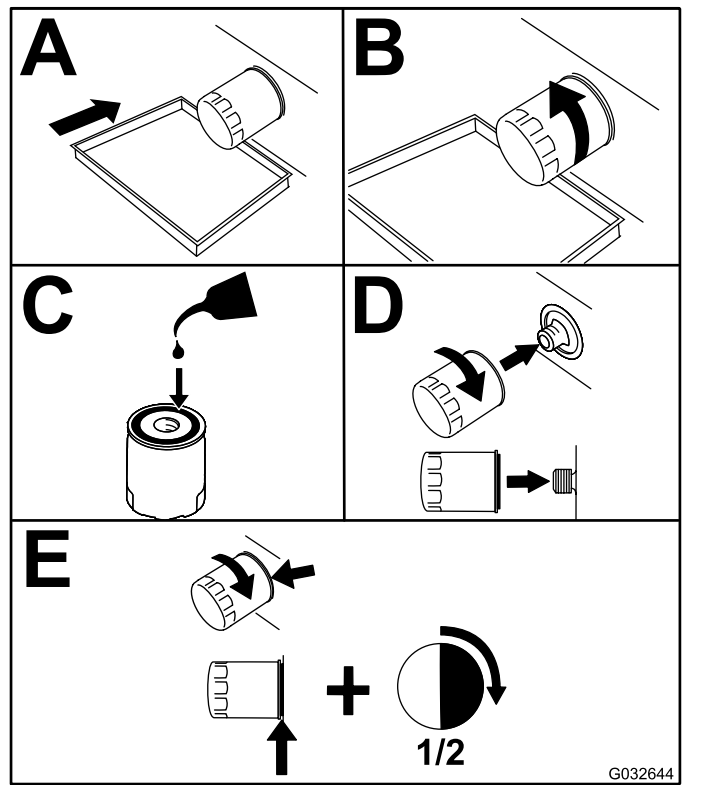

Figure 52

3. Add oil; refer to [Adding Engine Oil](#) (page 45).

Changing the Engine Oil

Service Interval: After the first 50 hours

Every 100 hours

1. Start the engine and let it run for 5 minutes.
Note: This warms the oil so it drains better.
2. Park the machine on a level surface.
3. Disengage the blade-control switch (PTO), move the motion-control levers to the NEUTRAL-LOCK position, and engage the parking brake.
4. Shut off the engine, remove the key, and wait for all moving parts to stop before leaving the operating position.

5. Place a pan below the oil drain. Remove the drain plug and let the oil drain completely (Figure 53).
6. Remove the oil filler cap from the top of the engine (Figure 55).

Note: This helps the oil to drain.

7. Install the drain plug and tighten it to 35 N·m (25-1/2 ft-lb).

Note: Dispose of the used oil at a recycling center.

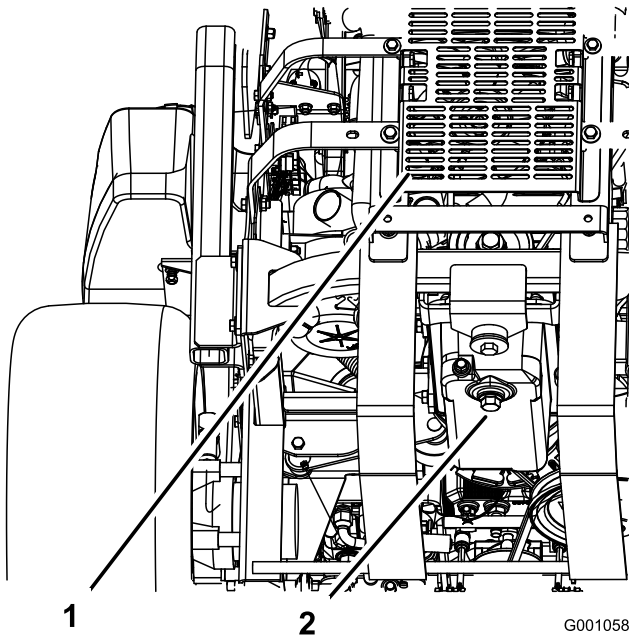

Figure 53

1. Back of the machine
2. Drain plug

Adding Engine Oil

1. Tilt the seat forward and remove the front engine panel (Figure 54).

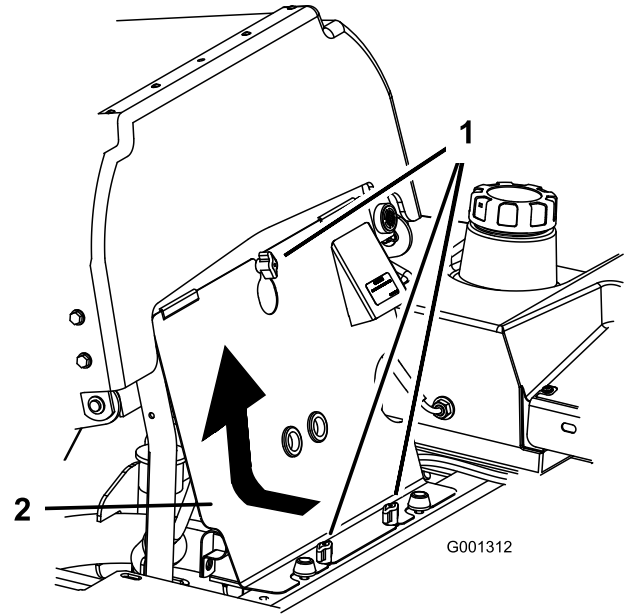

Figure 54

1. Knob
2. Front engine panel

2. Remove the oil-fill cap and dipstick (Figure 55).

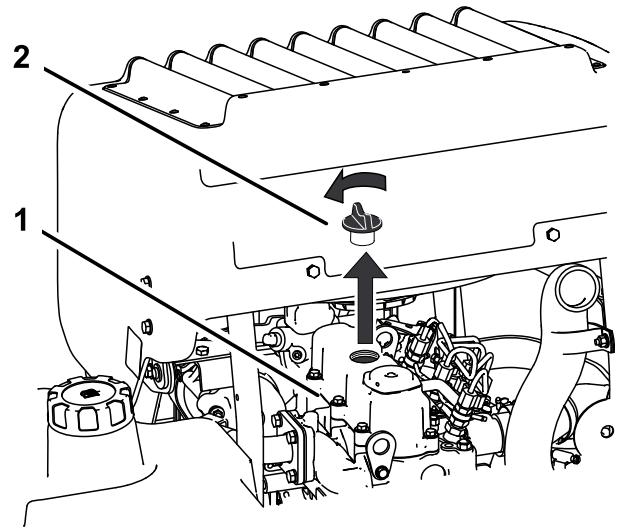

Figure 55

1. Engine
2. Oil-fill cap

3. Use a hose and funnel to add oil to the engine (Figure 56).
4. Add oil slowly, checking the level frequently with the dipstick until the level reaches the upper hole on the dipstick. For the correct oil type and viscosity to use in different temperature conditions, refer to [Servicing the Engine Oil](#) (page 42).

Fuel System Maintenance

Servicing the Fuel Filter and Water Separator

Service Interval: Every 40 hours—Drain the water separator.

Every 400 hours/Yearly (whichever comes first)—Replace the fuel filter (more often in dirty or dusty conditions).

Draining the Water Separator

1. Position the machine on a level surface.
2. Disengage the blade-control switch (PTO), move the motion-control levers to the NEUTRAL-LOCK position, and engage the parking brake.
3. Shut off the engine, remove the key, and wait for all moving parts to stop before leaving the operating position.
4. Locate the water separator at the back left of the machine.
5. Place a drain pan below the water separator.
6. Open the drain valve on the water separator approximately 1 turn to allow water and other contaminants to drain (Figure 58).
7. Close the drain valve when only diesel fuel comes out (Figure 58).

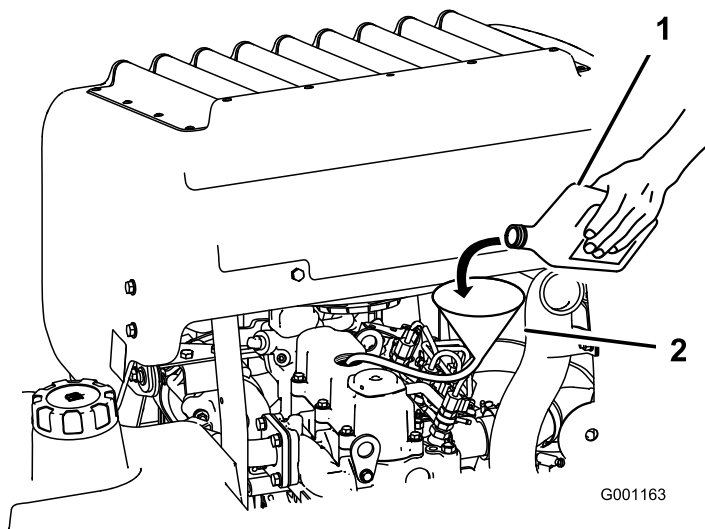

Figure 56

1. Engine oil
2. Funnel and hose

Important: Add the oil very slowly and do not block the opening of the filler hole (Figure 57). If you add oil too fast or block the hole, the oil could back up and foul the air intakes, causing engine damage.

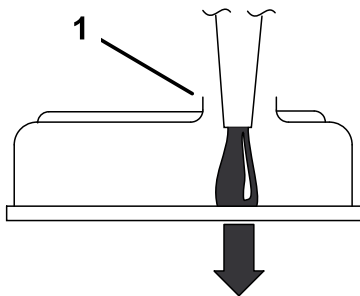

Figure 57

1. Note the clearance left in the filler opening.

5. Replace the dipstick and install the front engine panel.
6. Start the engine and run it at idle for 5 minutes.
7. Shut off the engine.
8. Wait 3 minutes and check the oil level.
9. Add oil, if required, to bring the level to the upper hole on the dipstick.
10. Replace the dipstick, filler cap, and the front engine panel.
11. Check for leaks.

Important: Do not overfill the crankcase with oil because this may cause engine damage.

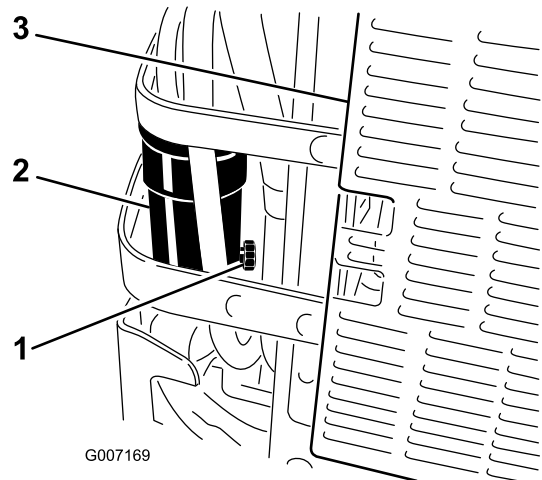

Figure 58

1. Drain valve
2. Water separator
3. Back of machine

Changing the Fuel Filter

Never install a dirty fuel filter if it is removed from the fuel line.

1. Allow the machine to cool down.
2. Disengage the blade-control switch (PTO), move the motion-control levers to the NEUTRAL-LOCK position, and engage the parking brake.
3. Shut off the engine, remove the key, and wait for all moving parts to stop before leaving the operating position.
4. Close the fuel shut-off valve (Figure 59).
5. Loosen the 2 hose clamps and disconnect the fuel lines from the fuel filter (Figure 59).
6. Install a new filter. Connect the fuel lines to the fuel filter and install the 2 hose clamps (Figure 59).
7. Open the fuel shut-off valve.
8. Start the engine and check for leaks.

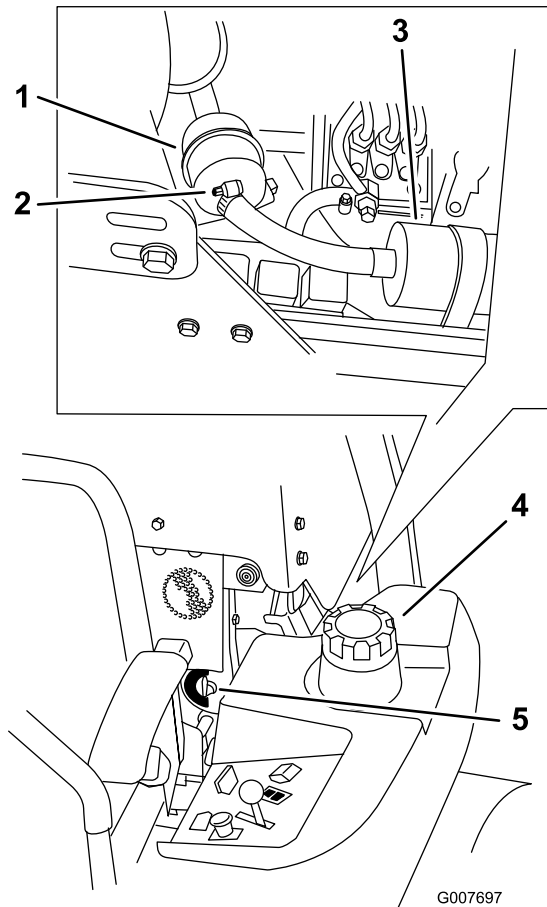

Figure 59

- | | |
|----------------|-------------------------|
| 1. Fuel filter | 4. Left side of machine |
| 2. Hose clamp | 5. Fuel-shutoff valve |
| 3. Fuel pump | |

Servicing the Fuel Tank

Do not attempt to drain the fuel tank. Ensure that an Authorized Service Dealer drains the fuel tank and services any components of the fuel system.

Electrical System Maintenance

Electrical System Safety

- Disconnect the battery before repairing the machine. Disconnect the negative terminal first and the positive last. Connect the positive terminal first and the negative last.
- Charge the battery in an open, well-ventilated area, away from sparks and flames. Unplug the charger before connecting or disconnecting the battery. Wear protective clothing and use insulated tools.

WARNING

CALIFORNIA Proposition 65 Warning

Battery posts, terminals, and related accessories contain lead and lead compounds, chemicals known to the State of California to cause cancer and reproductive harm. Wash hands after handling.

Servicing the Battery

⚠ DANGER

Battery electrolyte contains sulfuric acid, which is fatal if consumed and causes severe burns.

Do not drink electrolyte and avoid contact with skin, eyes or clothing. Wear safety glasses to shield your eyes and rubber gloves to protect your hands.

Removing the Battery

⚠ WARNING

Battery terminals or metal tools could short against metal machine components, causing sparks. Sparks can cause the battery gasses to explode, resulting in personal injury.

- When removing or installing the battery, do not allow the battery terminals to touch any metal parts of the machine.
- Do not allow metal tools to short between the battery terminals and metal parts of the machine.

⚠ WARNING

Incorrect battery cable routing could damage the machine and cables causing sparks. Sparks can cause the battery gasses to explode, resulting in personal injury.

- Always disconnect the negative (black) battery cable before disconnecting the positive (red) cable.
 - Always connect the positive (red) battery cable before connecting the negative (black) cable.
1. Disengage the blade-control switch (PTO), move the motion-control levers to the NEUTRAL-LOCK position, and engage the parking brake.
 2. Shut off the engine, remove the key, and wait for all moving parts to stop before leaving the operating position.
 3. Unlatch the seat and tilt the seat up.
 4. Remove the battery as shown in [Figure 60](#).

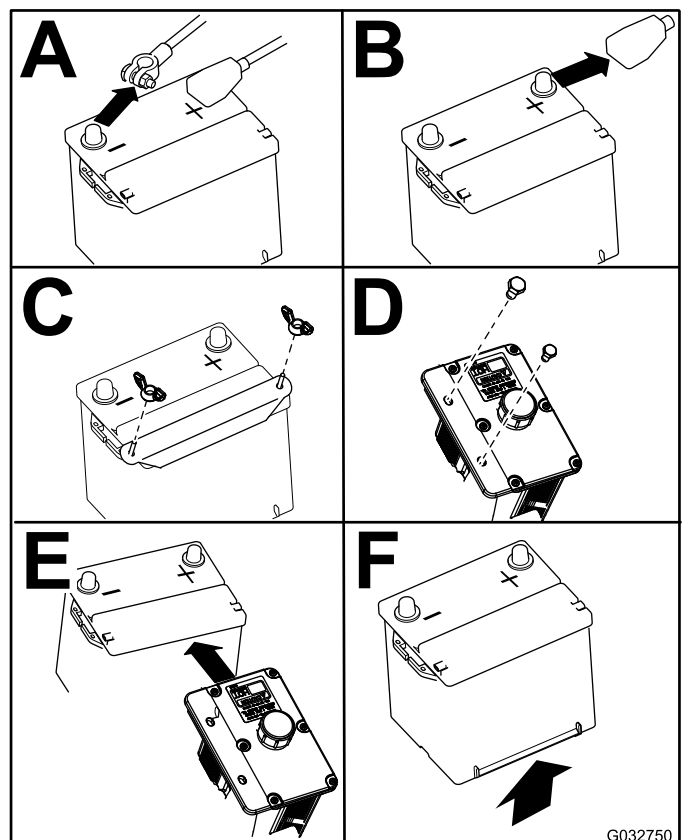

Figure 60

G032750
g032750

Installing the Battery

Note: Position the battery in the tray with the terminal posts opposite from the hydraulic tank.

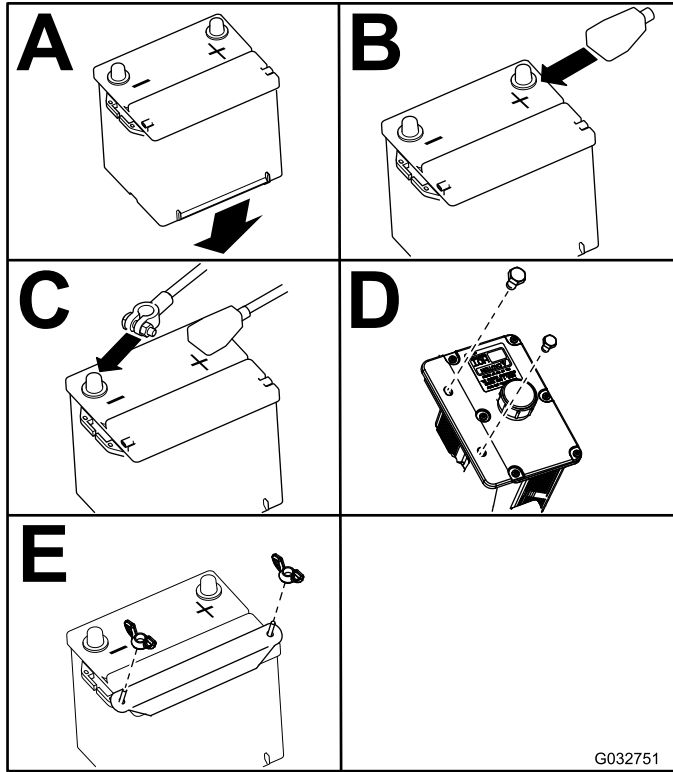

Figure 61

Charging the Battery

⚠ WARNING

Charging the battery produces gasses that can explode.

Never smoke near the battery and keep sparks and flames away from battery.

Important: Always keep the battery fully charged (1.265 specific gravity). This is especially important to prevent battery damage when the temperature is below 0°C (32°F).

1. Make sure that the filler caps are installed in battery. Charge battery for 10 to 15 minutes at 25 to 30 A or 30 minutes at 10 A.
2. When the battery is fully charged, unplug the charger from the electrical outlet, then disconnect the charger leads from the battery posts (Figure 62).
3. Install the battery in the machine and connect the battery cables, refer to [Installing the Battery](#) (page 49).

Note: Do not run the machine with the battery disconnected, electrical damage may occur.

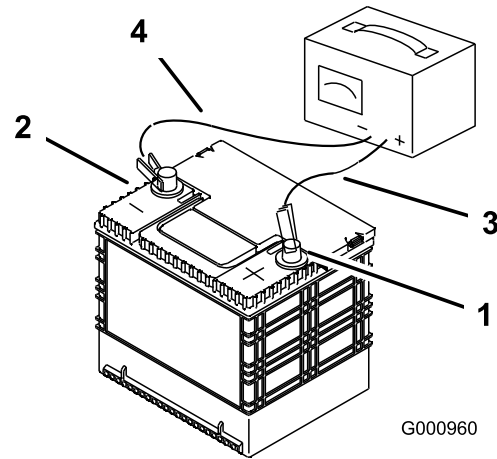

Figure 62

1. Positive battery post
2. Negative battery post
3. Red (+) charger lead
4. Black (-) charger lead

Servicing the Fuses

The electrical system is protected by fuses. It requires no maintenance, however, if a fuse blows check component/circuit for malfunction or short.

1. Unlatch the engine hood and raise the engine hood to gain access to fuse holder (Figure 63).
2. To replace the fuses, pull out on the fuse to remove it.
3. Install a new fuse (Figure 63).

Drive System Maintenance

Adjusting the Tracking

The machine has a knob for adjusting the tracking located under the seat.

Important: Adjust the handle neutral and hydraulic pump neutral before adjusting the tracking; refer to [Adjusting the Control Handle Neutral Position \(page 61\)](#) and [Setting the Hydraulic Pump Neutral Position \(page 66\)](#).

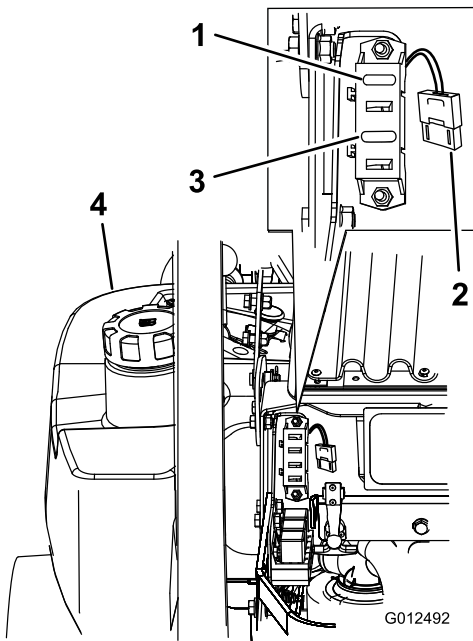

Figure 63

1. Ignition—30 A (F1)
2. Radiator fan—50 A (large, heavy duty fuse)
3. Clutch—10 A (F3)
4. Left fuel tank

1. Push both control levers forward the same distance.
 2. Check if the machine pulls to 1 side. If it does, shut off the machine and engage the parking brake.
 3. Unlatch the seat and tilt the seat forward to access the tracking knob.
- Note:** Determine the left and right sides of the machine from the normal operating position.
4. To make the machine go right, turn the knob toward the right of the machine; refer to [Figure 64](#).
 5. To make the machine go left, turn the knob toward the left of the machine; refer to [Figure 64](#).
 6. Repeat adjustment until the tracking is correct.

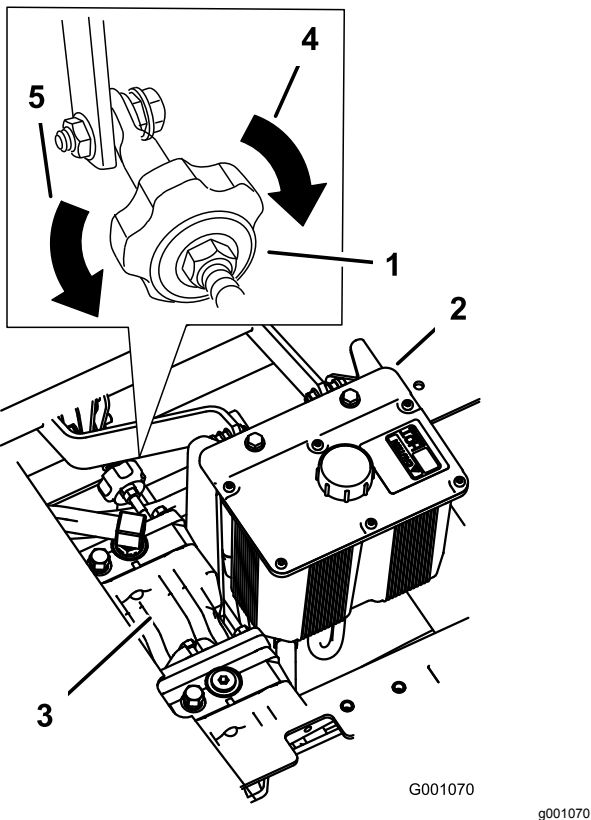

Figure 64

- | | |
|--------------------|----------------------------------|
| 1. Tracking knob | 4. Turn this way to track right. |
| 2. Hydraulic tank | 5. Turn this way to track left. |
| 3. Hydraulic pumps | |

Checking the Tire Pressure

Service Interval: Every 50 hours/Monthly (whichever comes first)

Maintain the air pressure in the rear tires at 90 kPa (13 psi). Uneven tire pressure can cause uneven cut. Check the tires when they are cold to get the most accurate pressure reading.

Note: The front tires are semi-pneumatic tires and do not require air pressure maintenance.

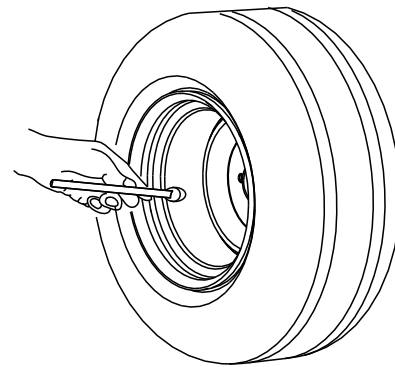

G001055

g001055

Figure 65

Checking the Wheel-Hub Slotted Nut

Service Interval: After the first 100 hours—Check the wheel-hub slotted nut.

Every 500 hours—Check the wheel-hub slotted nut.

Torque the slotted nut to 286 to 352 N·m (211 to 260 ft·lb).

Note: Do not use anti-seize compound on the wheel hub.

Adjusting the Caster-Pivot Bearing

Service Interval: Every 500 hours/Yearly (whichever comes first)

1. Disengage the blade-control switch (PTO), move the motion-control levers to the NEUTRAL-LOCK position, and engage the parking brake.
2. Shut off the engine, remove the key, and wait for all moving parts to stop before leaving the operating position.
3. Remove the dust cap from caster and tighten the locknut (Figure 66).
4. Tighten the locknut until the spring washers are flat, and then back off a 1/4 turn to properly set the preload on the bearings (Figure 66).

Important: Make sure that the spring washers are installed correctly as shown in Figure 66.

5. Install the dust cap (Figure 66).

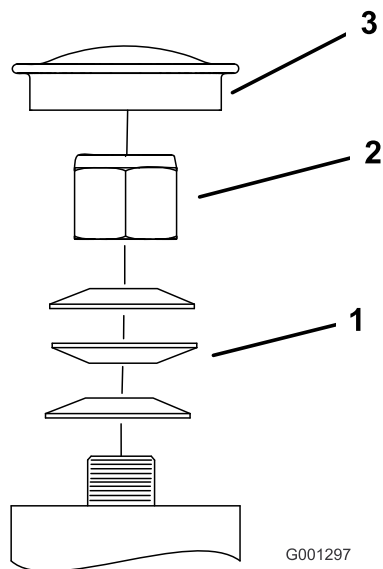

Figure 66

- | | |
|-------------------|-------------|
| 1. Spring washers | 3. Dust cap |
| 2. Locknut | |

G001297

g001297

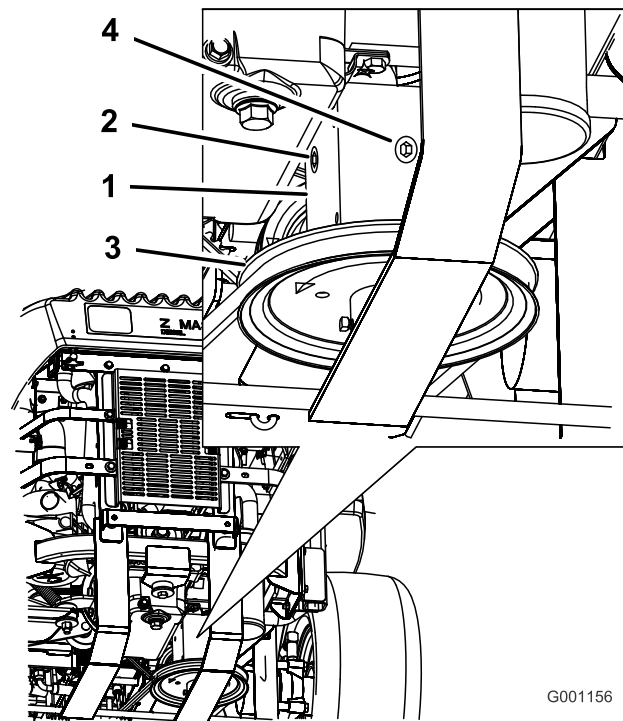

Figure 67

- | | |
|--------------|--------------|
| 1. Gearbox | 3. Pulley |
| 2. Side plug | 4. Rear plug |

G001156

g001156

Servicing the Gearbox

Checking the Gearbox-Oil Level

Service Interval: Every 100 hours

Use SAE 75W-90 synthetic gear lube.

1. Park the machine on a level surface.
2. Disengage the blade-control switch (PTO), move the motion-control levers to the NEUTRAL-LOCK position, and engage the parking brake.
3. Shut off the engine, remove the key, and wait for all moving parts to stop before leaving the operating position.
4. Remove the side or rear plug on the gearbox ([Figure 67](#)).
5. The oil should be up to the opening of the gearbox.
6. Add oil if needed to bring it to the correct level.

Changing the Gearbox Oil

Service Interval: After the first 100 hours

Yearly

Contact an Authorized Service Dealer to change the gearbox oil.

Adjusting the Electric Clutch

Service Interval: Every 500 hours

The clutch is adjustable to ensure proper engagement and proper braking.

1. Disengage the blade-control switch (PTO), move the motion-control levers to the NEUTRAL-LOCK position, and engage the parking brake.
2. Shut off the engine, remove the key, and wait for all moving parts to stop before leaving the operating position.
3. Unlatch the seat and tip it forward.
4. Loosen the front engine panel knobs and remove the panel.
5. Pull up on the spring-loaded idler pulley for the PTO-drive belt and remove the belt from the clutch pulley (Figure 68).

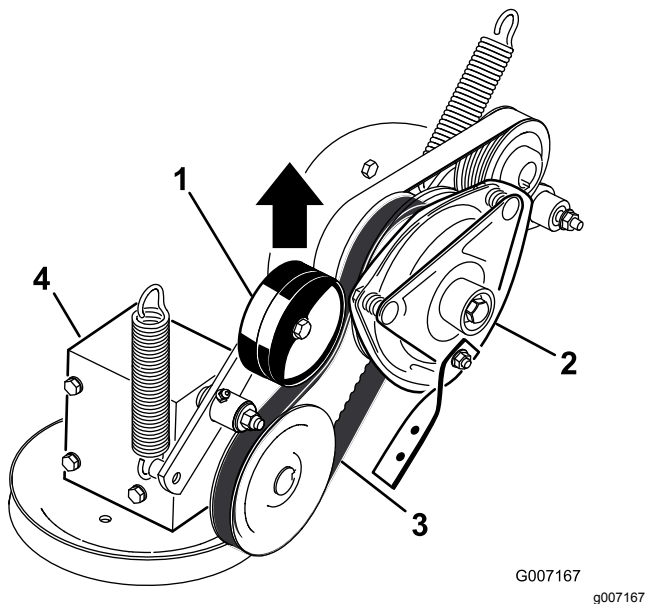

Figure 68

- | | |
|-------------------------------|-------------------|
| 1. Spring-loaded idler pulley | 3. PTO-drive belt |
| 2. Clutch | 4. Gearbox |

6. Unplug the electric connection for the clutch (Figure 69).
7. Remove the 2 bolts holding the rubber clutch strap to the mower frame (Figure 69).
8. Remove the center bolt holding the clutch to the engine shaft and remove the clutch and key (Figure 69).

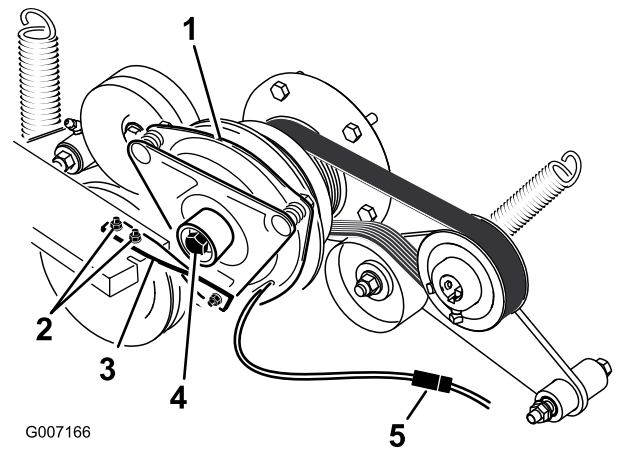

Figure 69

- | | |
|--------------------------------|--------------------------------|
| 1. Clutch | 4. Clutch center bolt |
| 2. 2 bolts and nuts for clutch | 5. Electrical connection strap |
| 3. Rubber clutch strap | |

9. Insert a 0.381 to 0.533 mm (0.015 to 0.021 inch) feeler gauge through an inspection slot in the side of the assembly (Figure 70).

Note: Make sure that it is between the armature and the rotor friction surfaces.

10. Tighten the locknuts until there is slight binding on the feeler gauge but it can be moved easily within the air gap (Figure 70).
11. Repeat this for the remaining slots.
12. Check each slot again and make slight adjustments until the feeler gauge between the rotor and armature has very slight contact between them.

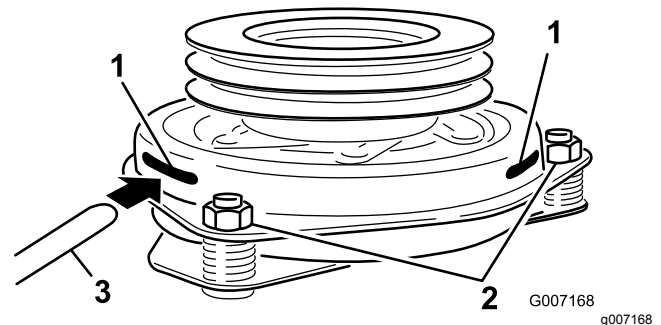

Figure 70

- | | |
|------------------|-----------------|
| 1. Slot | 3. Feeler gauge |
| 2. Adjusting nut | |

13. Install the clutch to the engine shaft with the key.
14. Apply thread-locking adhesive to the center bolt.
15. While holding the crank shaft at the back of the machine, install the center bolt and torque it to 68 N·m (50 ft·lb) (Figure 69).

16. Install the rubber clutch strap to the mower frame with the 2 previously removed bolts and nuts (Figure 69).
17. Pull up on the spring-loaded idler for the PTO-drive belt and install it onto the clutch pulley (Figure 68).
18. Plug in the electric connection for the clutch (Figure 69).
19. Install the front engine panel and tighten the knobs.
20. Lower down the seat.

Cooling System Maintenance

Servicing the Cooling System

⚠ DANGER

Discharge of hot pressurized coolant or touching hot radiator and surrounding parts can cause severe burns.

- Do not remove the radiator cap when the engine is hot. Always allow the engine to cool at least 15 minutes or until the radiator cap is cool enough to touch without burning your hand before removing the radiator cap.
- Do not touch the radiator and surrounding parts that are hot.

⚠ DANGER

The rotating shaft and fan can cause personal injury.

- Do not operate the machine without the covers in place.
- Keep your fingers, hands, and clothing clear of rotating fan and driveshaft.
- Shut off the engine and remove the ignition key before performing maintenance.

⚠ CAUTION

Swallowing engine coolant can cause poisoning.

- Do not swallow engine coolant.
- Keep out of reach from children and pets.

Checking the Radiator Coolant

Service Interval: Before each use or daily

After the first 8 hours

Every 100 hours

Fluid Type: 50/50 mix of extended life antifreeze/Dex-Cool® and water

Cooling System Capacity: 4.6 L (156 fl oz)

Note: Do not open the radiator cap. Doing this may induce air into the cooling system.

1. Position the machine on a level surface, shut off the engine, and engage the parking brake.
2. Unlatch the seat and tilt the seat up.
3. With the engine cool, check the overflow bottle level. The fluid needs to be up to the bump on the outside of the overflow bottle (Figure 71).
4. If the coolant level is low, add a 50/50 mix of extended life antifreeze/Dex-Cool® and water to the overflow bottle (Figure 71).
5. Add the 50/50 coolant mix to the overflow bottle and fill it to the indicator line on the bottle (Figure 71).

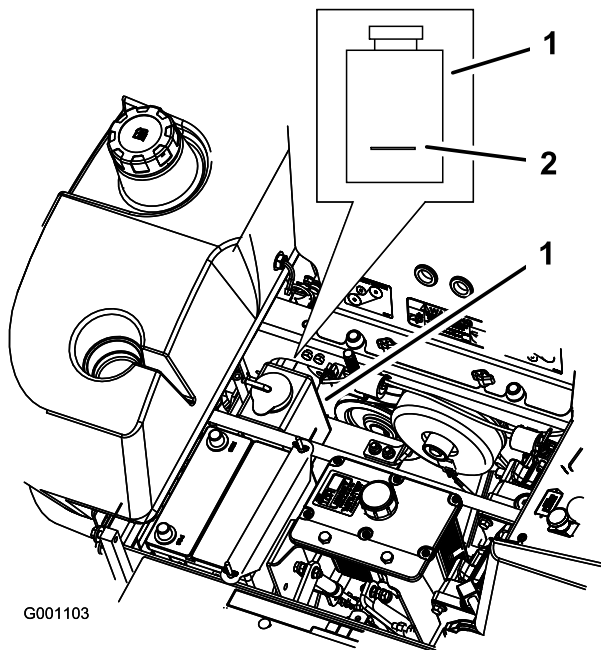

Figure 71

1. Antifreeze overflow bottle
2. Indicator line on side of overflow bottle

Cleaning the Hydraulic-Fluid Cooler and Radiator Screen

Service Interval: Before each use or daily

Before each use, check and clean the radiator screen and oil cooler. Remove any build-up of grass, dirt or other debris from the oil cooler and radiator screen with compressed air (Figure 72).

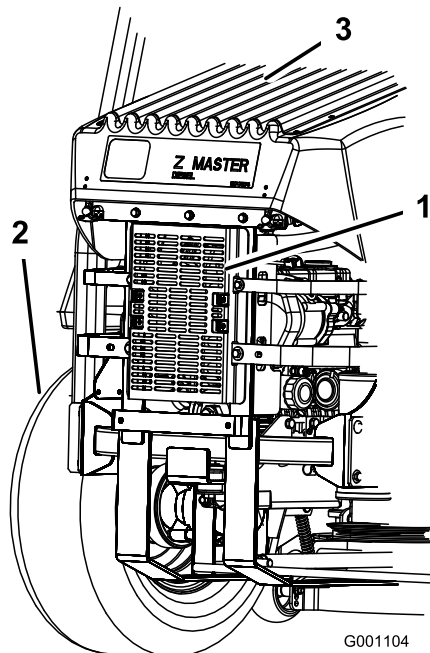

Figure 72

1. Hydraulic-fluid cooler
2. Left rear tire
3. Radiator screen

Changing the Engine Coolant

Service Interval: Yearly

Contact an Authorized Service Dealer for changing the coolant.

Brake Maintenance

Adjusting the Parking Brake

Service Interval: Every 25 hours

Every 200 hours

1. Engage the parking brake.
2. Measure the length of the spring (Figure 73).

Note: The measurement should be 64 mm (2-1/2 inches) between the washers.

3. If adjustment is necessary, disengage the parking brake, loosen the jam nut below the spring and adjust the nut directly below the spring (Figure 73).
4. Turn the nut until the correct measurement is obtained.

Note: Turn the nut clockwise to shorten spring length and turn counter-clockwise to lengthen the spring.

5. Tighten the 2 nuts together.
6. Engage the parking brake and check the measurement of the spring again.
7. If an adjustment is necessary, repeat the procedures above.
8. Repeat on the opposite side of machine.

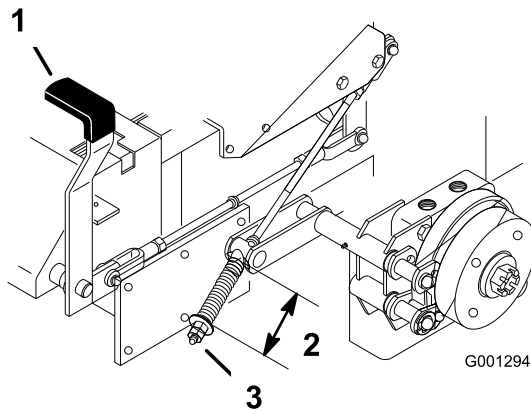

Figure 73

1. Brake lever in engaged position
2. Spring—64 mm (2-1/2 inches)
3. Adjusting nut and jam nut

Belt Maintenance

Inspecting the Belts

Service Interval: Every 100 hours

Check the belts for squealing when the belt is rotating, blades slipping when cutting grass, frayed belt edges, burn marks and cracks are signs of a worn mower belt. Replace the mower belt if any of these conditions are evident.

Replacing the Mower Belt

Squealing when the belt is rotating, blades slipping when cutting grass, frayed belt edges, burn marks and cracks are signs of a worn mower belt. Replace the mower belt if any of these conditions are evident.

1. Disengage the blade-control switch (PTO), move the motion-control levers to the NEUTRAL-LOCK position, and engage the parking brake.
2. Shut off the engine, remove the key, and wait for all moving parts to stop before leaving the operating position.
3. Remove the belt covers (Figure 74).

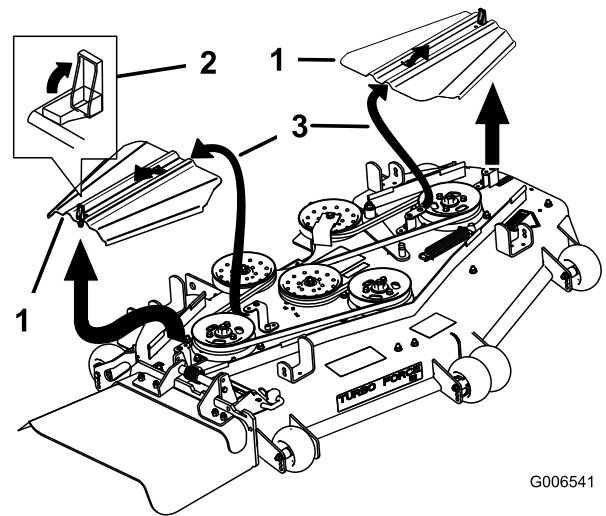
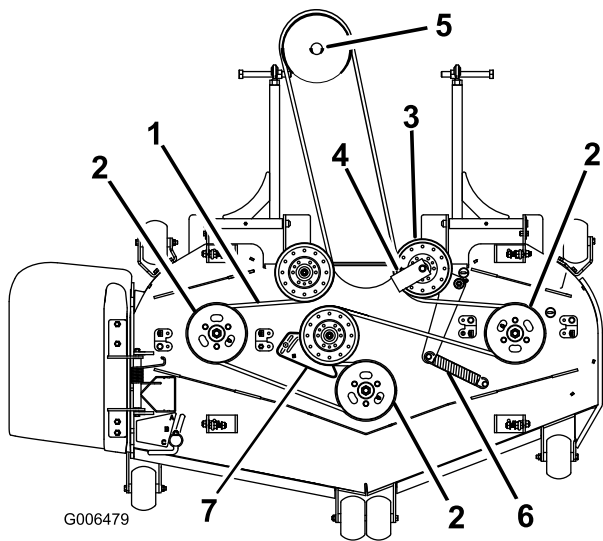

Figure 74

1. Belt cover
2. Latch
3. Insert slot into the tab

4. For 72-inch mowers, loosen the idler plate bolts holding the idler plate (Figure 77).
5. Remove the idler spring.
6. Remove the belt guide on the spring-loaded idler pulley shown in Figure 75 and Figure 77.
7. Remove the existing belt.
8. Install the new belt around the mower pulleys and the gearbox pulley under the engine (Figure 75).



G006479

g006479

Figure 75

- | | |
|------------------------------------|--|
| 1. Mower belt | 5. Gearbox pulley |
| 2. Mower spindle pulley | 6. Idler spring |
| 3. Spring-loaded idler pulley | 7. Idler plate (for 72-inch mowers only) |
| 4. Belt guide at a 45 degree angle | |

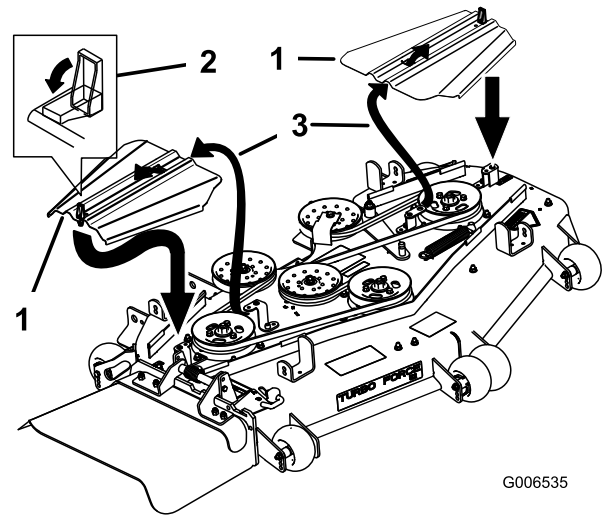

G006535

g006535

Figure 76

- | | |
|---------------|-----------------------------|
| 1. Belt cover | 3. Insert slot into the tab |
| 2. Latch | |

Adjusting the Mower Belt Tension

For 72-inch Mowers Only

Service Interval: After the first 8 hours

Important: To ensure proper mower belt tension, which will result in a longer belt life, check the mower belt tension after the 8 hours and every 8 hours, thereafter.

9. Install the belt guide on the spring-loaded idler at a 45 degree angle as shown in [Figure 75](#) and [Figure 77](#). Torque the bolt to 37 to 45 N·m (27 to 33 ft·lb).
10. Install the idler spring to the 2 posts ([Figure 75](#) and [Figure 77](#)).
11. For 72-inch mowers, adjust the belt tension, refer to [Belt Maintenance](#) (page 56).
12. Install the belt covers by sliding the cover into the tab, install the bolts, and close the latches ([Figure 76](#)).

1. Disengage the blade-control switch (PTO), move the motion-control levers to the NEUTRAL-LOCK position, and engage the parking brake.
2. Shut off the engine, remove the key, and wait for all moving parts to stop before leaving the operating position.
3. Adjust the mower deck to the 76 mm (3 inches) height-of-cut position.
4. Measure the spring length ([Figure 77](#)). If the spring length is between 25.4 to 26 cm (10 to 10-1/4 inches), from post to post, no adjustment is needed.
5. Loosen the bolts holding the idler plate ([Figure 77](#)).
6. Insert a ratchet or breaker bar into the square hole in the idler plate to adjust the tension ([Figure 77](#)).
7. Rotate the ratchet or breaker bar to move the idler plate until the idler spring is between 25.4 to 26.0 cm (10 to 10-1/4 inches) from post to post as shown in [Figure 77](#).

8. While holding the belt tension and spring length, tighten the idler plate bolts that secure the idler plate (Figure 77).

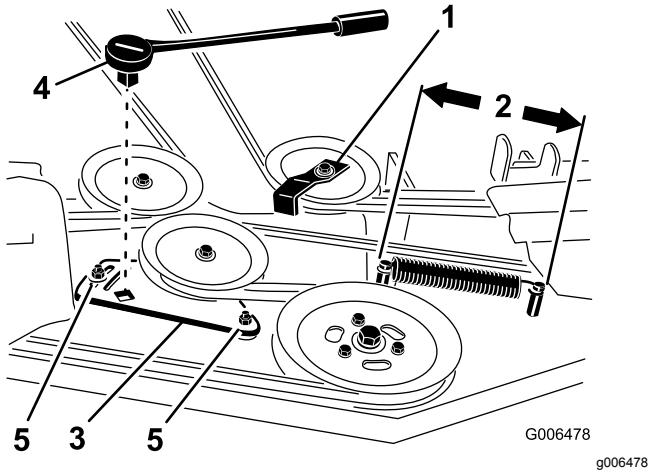

Figure 77

1. Belt guide (install at a 45 degree angle)
2. Idler spring length (between 25.4 to 26.0 cm (10 to 10-1/4 inches))
3. Idler plate
4. Ratchet or breaker bar
5. Idler plate bolt

Replacing the PTO-Drive Belt

Service Interval: Every 50 hours—Check the PTO-drive belt.

1. Disengage the blade-control switch (PTO), move the motion-control levers to the NEUTRAL-LOCK position, and engage the parking brake.
2. Shut off the engine, remove the key, and wait for all moving parts to stop before leaving the operating position.
3. Loosen the front engine panel knobs and remove the panel (Figure 78).

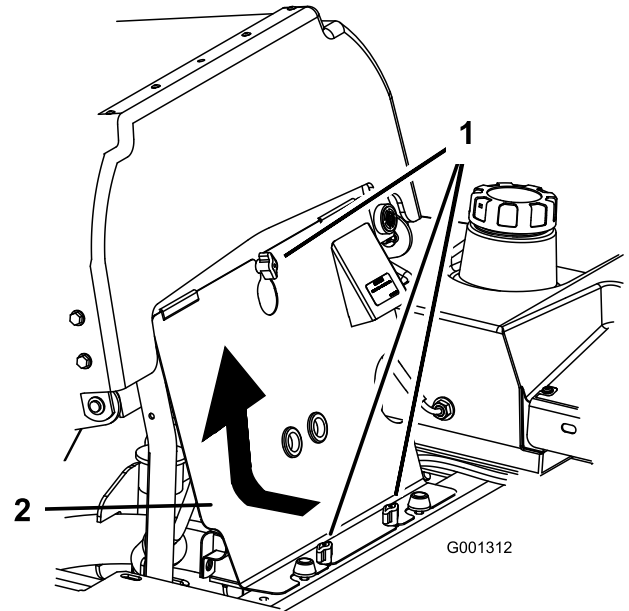

Figure 78

1. Knob
2. Front engine panel

4. Remove the spring from the idler arm (Figure 79).
5. Remove the clutch stop bracket.
6. Remove the old PTO-drive belt.
7. Install the PTO-drive belt around the clutch pulley and the gearbox pulley (Figure 79).

8. Install the rubber clutch stop.
9. Install the spring to the idler arm (Figure 79).

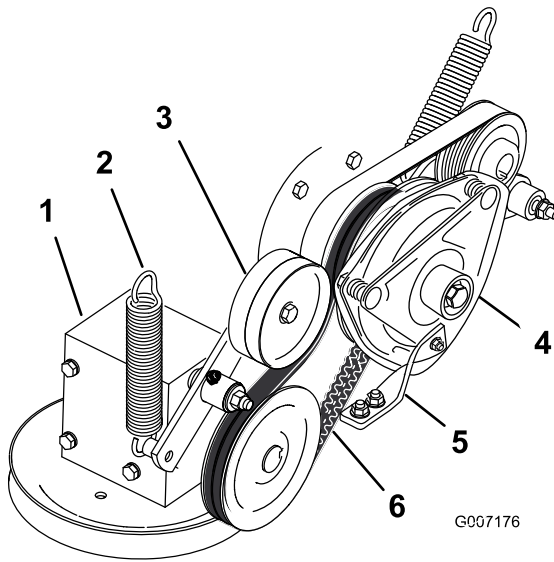

Figure 79

- | | |
|-------------------------------|-----------------------|
| 1. Gearbox | 4. Clutch |
| 2. Spring | 5. Rubber clutch stop |
| 3. Spring-loaded idler pulley | 6. PTO-drive belt |

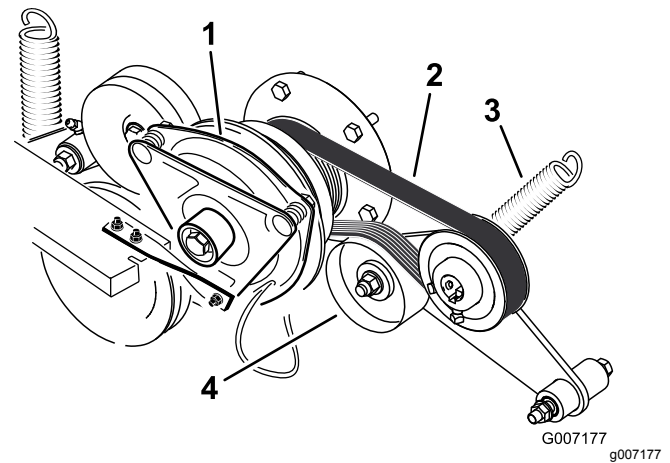

Figure 80

- | | |
|--------------------|-------------------------------|
| 1. Clutch | 3. Spring |
| 2. Pump drive belt | 4. Spring-loaded idler pulley |

Replacing the Pump Drive Belt

Service Interval: Every 50 hours—Check the pump drive belt.

Note: Remove the PTO-drive belt first if the pump drive belt needs to be replaced.

1. Tilt the seat forward and remove the front engine panel.
2. Remove the PTO-drive belt.
3. Remove the spring from the idler arm (Figure 80).
4. Install the new belt around the engine and hydraulic pump pulley (Figure 80).
5. Install the PTO-drive belt.
6. Install the spring to the idler arm (Figure 80).

Replacing and Tensioning the Alternator Belt

Replacing the Alternator Belt

Service Interval: Every 50 hours—Check the alternator belt.

1. Disengage the blade-control switch (PTO), move the motion-control levers to the NEUTRAL-LOCK position, and engage the parking brake.
2. Shut off the engine, remove the key, and wait for all moving parts to stop before leaving the operating position.
3. Remove the 4 bolts holding the oil cooler shield to the rear frame (Figure 81).
4. Remove the 3 bolts holding the engine straps to the side of the machine (Figure 81).

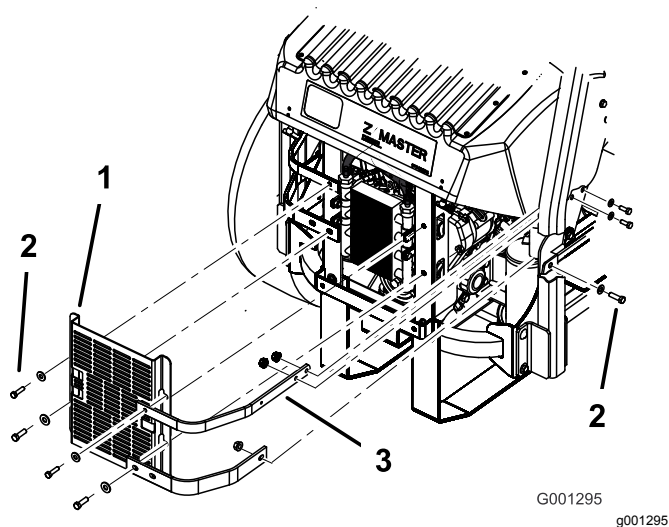

Figure 81

- | | |
|----------------------|------------------|
| 1. Oil cooler shield | 3. Engine straps |
| 2. Bolts | |

5. Remove the 4 bolts holding the oil cooler and position the oil cooler to the side (Figure 82).
6. Remove the 2 bolts holding the fan and fan plate to the machine (Figure 82).

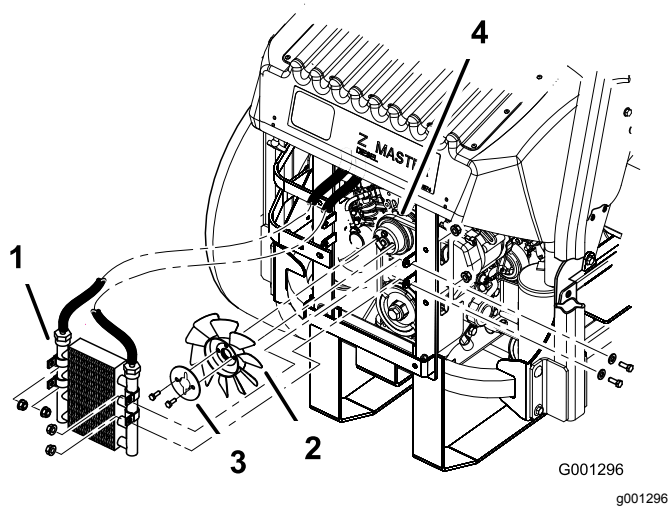

Figure 82

- | | |
|---------------|--------------------|
| 1. Oil cooler | 3. Fan plate |
| 2. Fan | 4. Alternator belt |

7. Loosen the bottom bolt and remove the upper bolt holding the alternator and cover (Figure 83).
8. Rotate the alternator cover to the side and remove the belt from the pulleys and alternator.
9. Install a new belt around the pulleys and the alternator (Figure 83).
10. Install the fan and fan plate to the machine with the 2 bolts previously removed (Figure 82).
11. Install the oil cooler with the 4 bolts previously removed (Figure 82).

12. Install the oil cooler shield and engine straps to the rear frame with the 4 bolts previously removed (Figure 81).
13. Install the engine straps to the side of the machine (Figure 81).
14. Tighten the bottom bolt and install the upper bolt holding the alternator and cover (Figure 83).

Tensioning the Alternator Belt

1. Place a handle between the alternator and cylinder block.
2. Adjust the alternator to the outside until there is 7 to 9 mm (1/4 to 11/32 inch) deflection in the belt between the engine and the alternator pulleys with 10 kg (22.1 lb) of force ([Figure 83](#)).
3. Tighten the alternator bolts.
4. Check the deflection in the belt again and adjust the belt if needed.
5. If the deflection is correct, tighten the bottom and upper bolt ([Figure 83](#)).

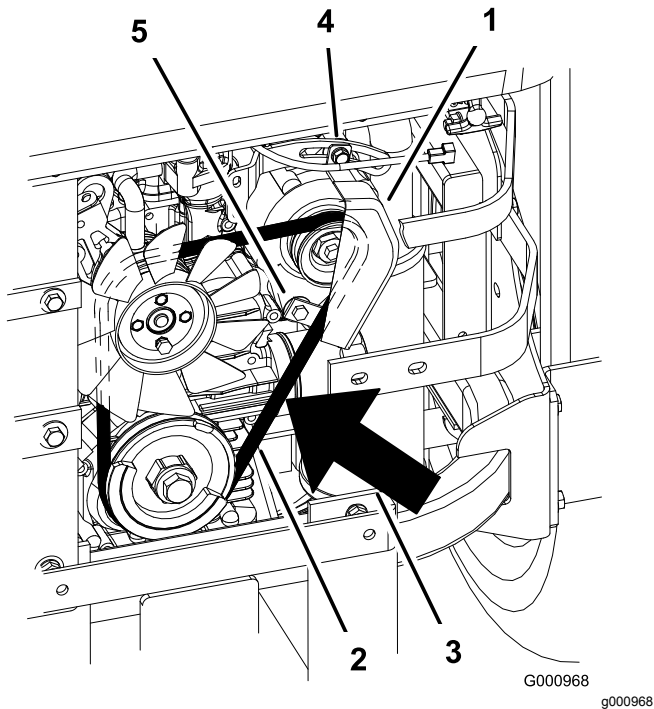

Figure 83

- | | |
|---|----------------|
| 1. Alternator | 4. Top bolt |
| 2. Alternator belt | 5. Bottom bolt |
| 3. Deflection—7 to 9 mm (1/4 to 11/32 inch) with 10 kg (22.1 lb) of force | |

Controls System Maintenance

Adjusting the Control Handle Neutral Position

If the motion-control levers do not align, or move easily into the console notch, adjustment is required. Adjust each lever, spring and rod separately.

Note: The motion-control levers must be installed correctly.

1. Disengage the blade-control switch (PTO), move the motion-control levers to the NEUTRAL-LOCK position, and engage the parking brake.
2. Shut off the engine, remove the key, and wait for all moving parts to stop before leaving the operating position.
3. Unlatch the seat and tilt the seat forward.
4. Begin with either the left or right motion-control lever.
5. Move the lever to the neutral position but not locked ([Figure 84](#)).
6. Pull the lever back until the clevis pin (on arm below pivot shaft) contacts the end of the slot (just beginning to put pressure on the spring) as shown in [Figure 84](#).
7. Check where the control lever is relative to notch in console ([Figure 84](#)).

Note: It should be centered, allowing lever to pivot outward to the NEUTRAL-LOCK position.

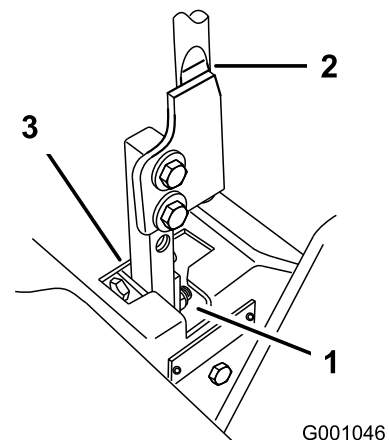

Figure 84

- | | |
|--------------------------|---------------------|
| 1. NEUTRAL-LOCK position | 3. NEUTRAL position |
| 2. Control lever | |

8. If adjustment is needed, loosen the nut and jam nut against the yoke ([Figure 85](#)).

- Apply slight rearward pressure on the motion-control lever, turn the head of the adjustment bolt in the appropriate direction until the control lever is centered in the NEUTRAL-LOCK position (Figure 85).

Note: Keeping rearward pressure on the lever keeps the pin at the end of the slot and allow the adjustment bolt to move the lever to the appropriate position.

- Tighten the nut and jam nut (Figure 85).
- Repeat for the opposite side of the machine.

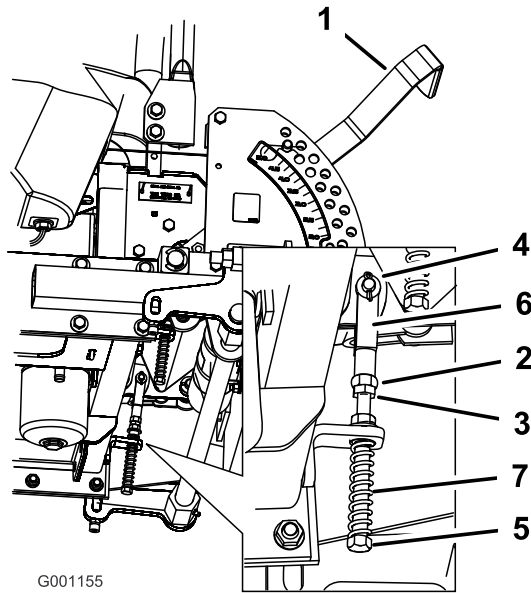

Figure 85

- | | |
|------------------------|--------------------|
| 1. Height-of-cut lever | 5. Adjustment bolt |
| 2. Nut against yoke | 6. Yoke |
| 3. Jam nut | 7. Spring |
| 4. Clevis pin in slot | |

Hydraulic System Maintenance

Hydraulic System Safety

- Ensure that all hydraulic-fluid hoses and lines are in good condition and all hydraulic connections and fittings are tight before applying pressure to the hydraulic system.
- Keep your body and hands away from pinhole leaks or nozzles that eject high-pressure hydraulic fluid.
- Use cardboard or paper to find hydraulic leaks.
- Safely relieve all pressure in the hydraulic system before performing any work on the hydraulic system.
- Seek immediate medical attention if fluid is injected into skin. Injected fluid must be surgically removed within a few hours by a doctor.

Servicing the Hydraulic System

Hydraulic-Fluid Type: Toro® HYPR-OIL™ 500 hydraulic fluid or Mobil® 1 15W-50 fluid

Hydraulic System Fluid Capacity: 3.9 L (132 oz)

Important: Use the specified fluid. Other fluids could cause system damage.

Checking the Hydraulic-Fluid Level

Service Interval: After the first 8 hours

Every 25 hours

Note: There are 2 ways of checking the hydraulic fluid. One is when the fluid is warm and one is when the fluid is cold. The baffle inside the tank has 2 levels depending if the fluid is warm or cold.

- Position the machine on a level surface and engage the parking brake.
- Disengage the blade-control switch (PTO), move the motion-control levers to the NEUTRAL-LOCK position, and engage the parking brake.
- Shut off the engine, remove the key, and wait for all moving parts to stop before leaving the operating position.
- Clean the area around the filler neck of the hydraulic tank (Figure 86).

5. Remove the cap from the filler neck and look inside to check if there is fluid in the reservoir (Figure 86).
6. If there is no fluid, add fluid to the reservoir until it reaches the cold level of the baffle.
7. Run the machine at low idle for 15 minutes to allow any air to purge out of the system and warm the fluid; refer to [Starting and Shutting Off the Engine](#) (page 25).

Note: Check the fluid level while the fluid is warm. The fluid should be between cold and hot.

8. If required, add fluid to the hydraulic tank.

Note: The fluid level should be to the top of the hot level of the baffle, when the fluid is hot (Figure 86).

9. Install cap on filler neck.

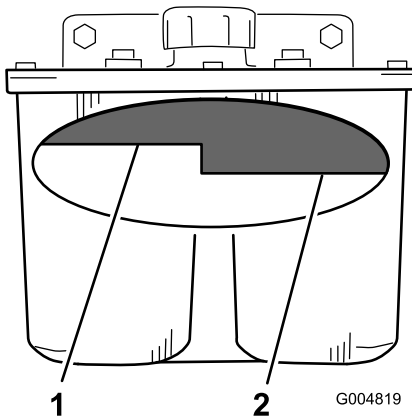

Figure 86

1. Hot fluid level-full
2. Cold fluid level-full

⚠ WARNING

Hydraulic fluid escaping under pressure can penetrate skin and cause injury.

- **If hydraulic fluid is injected into the skin it must be surgically removed within a few hours by a doctor familiar with this type of injury. Gangrene may result if this is not done.**
- **Keep your body and hands away from pin hole leaks or nozzles that eject high-pressure hydraulic fluid.**
- **Use cardboard or paper to find hydraulic leaks.**
- **Safely relieve all pressure in the hydraulic system before performing any work on the hydraulic system.**
- **Make sure that all hydraulic-fluid hoses and lines are in good condition and all hydraulic connections and fittings are tight before applying pressure to hydraulic system.**

Replacing the Hydraulic Filter and Fluid

Service Interval: After the first 25 hours

Every 250 hours—Change the hydraulic filter and hydraulic fluid when using Mobil® 1 fluid.

Every 500 hours—Change the hydraulic filter and hydraulic fluid when using Toro® HYPR-OIL™ 500 hydraulic fluid.

Use summer filter above 0°C (32°F)

Use winter filter below 0°C (32°F)

1. Disengage the blade-control switch (PTO), move the motion-control levers to the NEUTRAL-LOCK position, and engage the parking brake.
2. Shut off the engine, remove the key, and wait for all moving parts to stop before leaving the operating position.
3. Place drain pan under filter, remove the old filter and wipe the filter adapter gasket surface clean (Figure 87).

Important: Do not substitute automotive oil filter or severe hydraulic system damage may result.

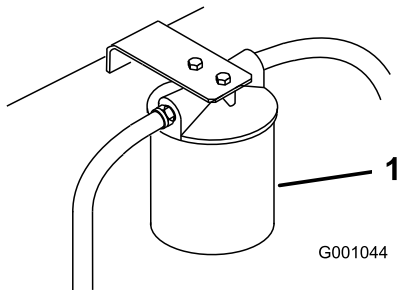

Figure 87

1. Hydraulic filter

4. Remove the right hydraulic line that comes into the adapter (Figure 88).
5. Allow the fluid to drain out of the system into the drain pan.
6. Install the right hydraulic line to the adapter (Figure 88).

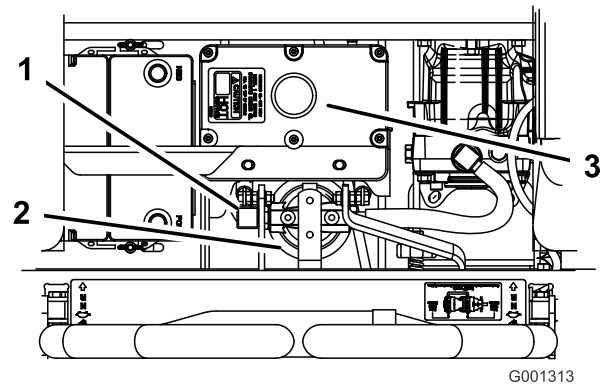

Figure 88

1. Right hydraulic line
2. Hydraulic filter
3. Hydraulic tank

7. Apply a thin coat to the rubber gasket on the replacement filter (Figure 89).
8. Install the replacement hydraulic filter onto the filter adapter.
Note: Do not tighten.
9. Fill the hydraulic tank with hydraulic fluid until the fluid overflows the filter and then turn the fluid filter clockwise until the rubber gasket contacts the filter adapter, then tighten the filter an additional 1/2 turn (Figure 89).
10. Clean up any spilled fluid.
11. Add fluid to the cold level of the baffle in the hydraulic tank.
12. Start the engine and let it run for about 2 minutes to purge air from the system.
13. Shut off the engine and check for leaks.
Note: If 1 or both wheels do not drive, refer to [Bleeding the Hydraulic System \(page 65\)](#).
14. Check the fluid level while the fluid is warm.
Note: The fluid should be between cold and hot.
15. If required, add fluid to the hydraulic tank.
Note: Do not overfill.

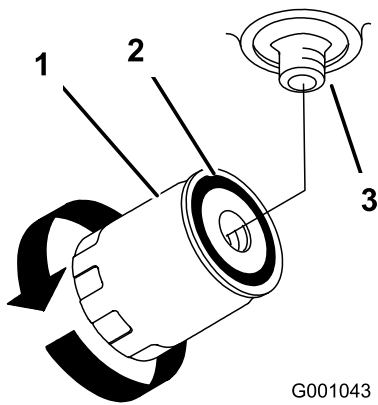

Figure 89

-
- 1. Hydraulic filter
 - 2. Gasket
 - 3. Adapter

Bleeding the Hydraulic System

The traction system is self bleeding, however, it may be necessary to bleed the system if fluid is changed or after work is performed on the system.

1. Raise the rear of the machine so that the wheels are off the ground and support with jack stands.
2. Start the engine and run at low idle speed and engage the lever and traction on 1 side and spin the wheel by hand.
3. When the wheel begins to spin on its own, keep it engaged until the wheel drives smoothly (minimum 2 minutes).
4. Check the hydraulic-fluid level and add as required to maintain proper level.
5. Repeat this procedure on the opposite wheel.

Checking the Hydraulic Hoses

Service Interval: Every 100 hours

Check the hydraulic hoses for leaks, loose fittings, kinked lines, loose mounting supports, wear, weather and chemical deterioration. Make necessary repairs before operating the machine.

Note: Keep areas around the hydraulic system clean from grass and debris buildup.

⚠ WARNING

Hydraulic fluid escaping under pressure can penetrate skin and cause injury.

- If hydraulic fluid is injected into the skin it must be surgically removed within a few hours by a doctor familiar with this type of injury. Gangrene may result if this is not done.
- Keep your body and hands away from pin hole leaks or nozzles that eject high-pressure hydraulic fluid.
- Use cardboard or paper to find hydraulic leaks.
- Safely relieve all pressure in the hydraulic system before performing any work on the hydraulic system.
- Make sure that all hydraulic-fluid hoses and lines are in good condition and all hydraulic connections and fittings are tight before applying pressure to hydraulic system.

Setting the Hydraulic Pump Neutral Position

Note: Adjust the handle neutral first. That needs to be correct before the following adjustment can be made.

This adjustment must be made with drive wheels turning.

⚠ DANGER

Mechanical or hydraulic jacks may fail to support the machine and cause a serious injury.

- Use a jack stand when supporting the machine.
- Do not use hydraulic jacks.

⚠ WARNING

The engine must be running so that you can adjust the motion control. Any contact with moving parts or hot surfaces may cause personal injury.

Keep your hands, feet, face, clothing and other body parts away from rotating parts, muffler and other hot surfaces.

1. Raise the frame and block up the machine so that the drive wheels can rotate freely.
2. Disconnect the electrical connector from the seat safety switch. Temporarily install a jumper wire across terminals in the wire-harness connector.
3. Unlatch the seat and slide seat forward.
4. Disconnect the seat rod and tilt the seat fully forward.

Setting the Right Hydraulic Pump Neutral Position

1. Start the engine, open the throttle 1/2 way and disengage parking brake; refer to [Starting and Shutting Off the Engine \(page 25\)](#).

Note: The motion-control lever must be in neutral while making any adjustments.

2. Adjust the pump rod length by rotating the knob, in the appropriate direction, until the wheel is still or slightly creeping in reverse ([Figure 90](#)).
3. Move the motion-control lever forward and reverse, then back to neutral.

Note: The wheel must stop turning or slightly creep in reverse.

- Open the throttle to FAST.

Note: Make sure that the wheel remains stopped or slightly creeps in reverse; adjust if necessary.

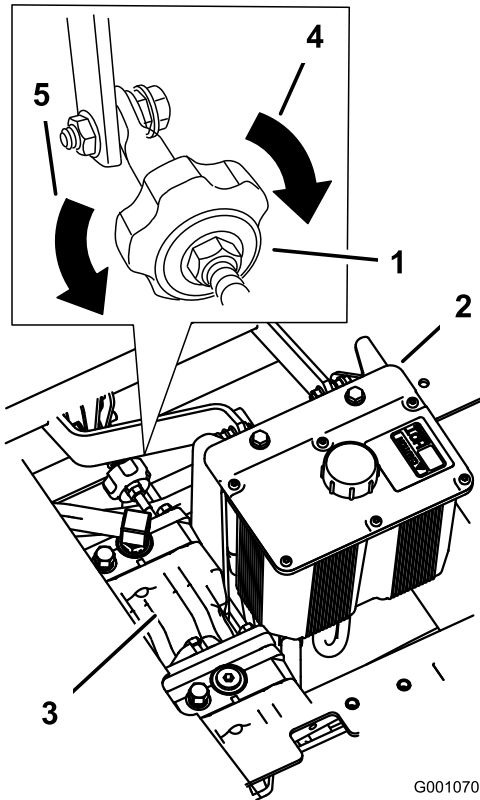

Figure 90

- | | |
|--------------------|---------------------------------|
| 1. Tracking knob | 4. Turn this way to track right |
| 2. Hydraulic tank | 5. Turn this way to track left |
| 3. Hydraulic pumps | |

Setting the Left Hydraulic Pump Neutral Position

- Loosen the locknuts at the ball joints on the pump control rod (Figure 91).
 - Start the engine, open the throttle 1/2 way and disengage parking brake; refer to [Starting and Shutting Off the Engine](#) (page 25).
- Note:** The motion-control lever must be in neutral while making any adjustments.
- Note:** The front nut on the pump rod has left-hand threads.
- Adjust the pump rod length by rotating double nuts on rod, in the appropriate direction, until wheel is still or slightly creeps in reverse (Figure 91).
 - Move the motion-control lever forward and reverse, then back to neutral. The wheel must stop turning or slightly creep in reverse.
 - Open the throttle to fast. Make sure that the wheel remains stopped or slightly creeps in reverse, adjust if necessary.
 - Tighten the locknuts at the ball joints (Figure 91).

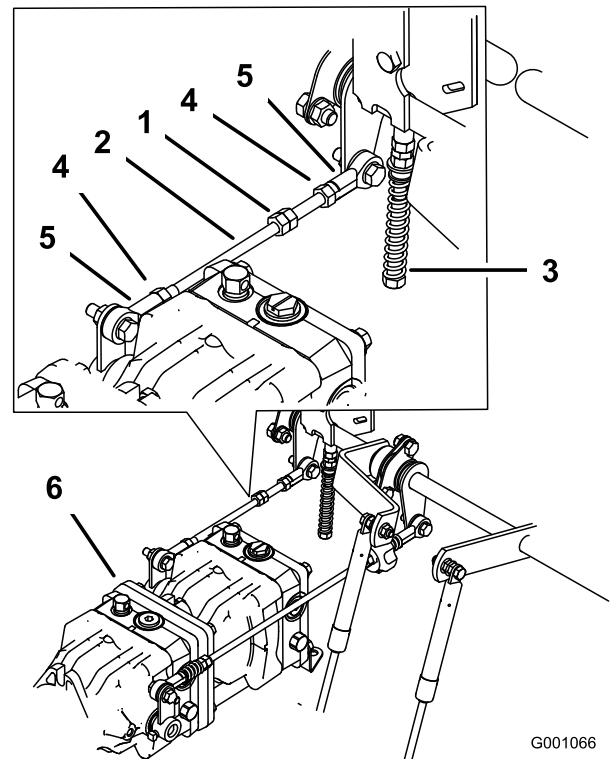

Figure 91

- | | |
|--------------------|---------------|
| 1. Double nuts | 4. Locknut |
| 2. Pump rod | 5. Ball joint |
| 3. Adjustment bolt | 6. Pumps |

⚠ WARNING

The electrical system does not perform proper safety shut off with the jumper wire installed.

- Remove the jumper wire from the wire harness connector and plug the connector into the seat switch when you complete the adjustment.
 - Never operate the machine with the jumper installed and the seat switch bypassed.
7. After both pump neutrals are set, shut off the machine.
 8. Remove the jumper wire from the wire harness connector and plug the connector into the seat switch.
 9. Install the seat rod and lower the seat into position.
 10. Remove the jack stands.

Mower Deck Maintenance

Leveling the Mower at 3 Positions

Important: There are only 3 measuring positions needed to level the mower.

Setting Up the Machine

1. Position mower on a flat surface.
2. Disengage the blade-control switch (PTO), move the motion-control levers to the NEUTRAL-LOCK position, and engage the parking brake.
3. Shut off the engine, remove the key, and wait for all moving parts to stop before leaving the operating position.
4. Check tire pressure of the tires; if needed, adjust to 90 kPa (13 psi).
5. Lower the mower to the 76 mm (3 inches) height-of-cut position.
6. Inspect the 4 chains.

Note: The chains need to have tension.

Note: Adjust the rear chains to the top of the slot, where they are attached to the mower.

- If a rear chain is loose, lower (loosen) the front-support arm on the same side; refer to [Adjusting the Front-to-Rear Mower Pitch \(page 69\)](#).
- If a front chain is loose, raise (tighten) the front-support arm for that chain; refer to [Adjusting the Front-to-Rear Mower Pitch \(page 69\)](#).

Leveling the Mower Side-to-Side

1. Position the **right** blade side-to-side (Figure 92).

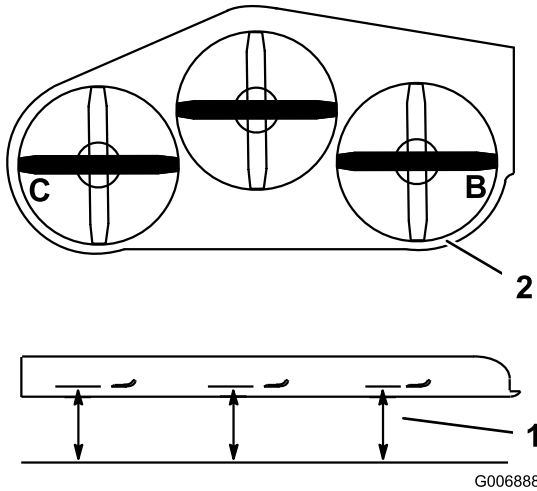

Figure 92

1. Measure here from blade to hard surface
2. Measure at B and C to hard surface
3. Measure the right blade at the **B** location, from a level surface to the cutting edge of the blade tip (Figure 92).
4. Record this measurement. This measurement needs to be 80 to 83 mm (3-1/8 to 3-1/4 inches).
5. Position the left blade side-to-side (Figure 92).
6. Measure the left blade at the **C** location (Figure 92), from a level surface to the cutting edge of the blade tip.
7. Record this measurement. This measurement needs to be 80 to 83 mm (3-1/8 to 3-1/4 inches).
8. If the measurements at positions **B** or **C** are not correct, loosen the bolt attaching the rear chain to the rear-support arm (Figure 93).

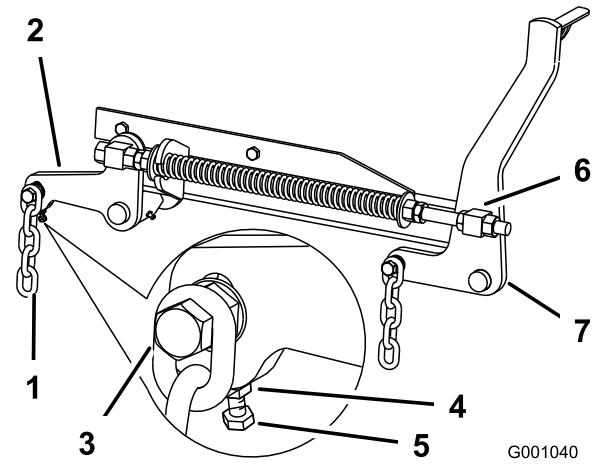

Figure 93

1. Rear chain
 2. Rear-support arm
 3. Bolt
 4. Jam nut
 5. Adjustment bolt
 6. Front swivel
 7. Front-support arm
 8. Loosen the jam nut under the rear-support arm and adjust the adjustment bolt to get a measurement of 80 to 83 mm (3-1/8 to 3-1/4 inches); refer to Figure 93.
- Note:** It is recommended that both sides of the mower are adjusted the same distance.
9. Tighten the jam nut under the rear-support arm and tighten the bolt securing the chain to the rear-support arm.
 10. Adjust the opposite side if needed.

Adjusting the Front-to-Rear Mower Pitch

1. Position the **right** blade front-to-rear (Figure 94).

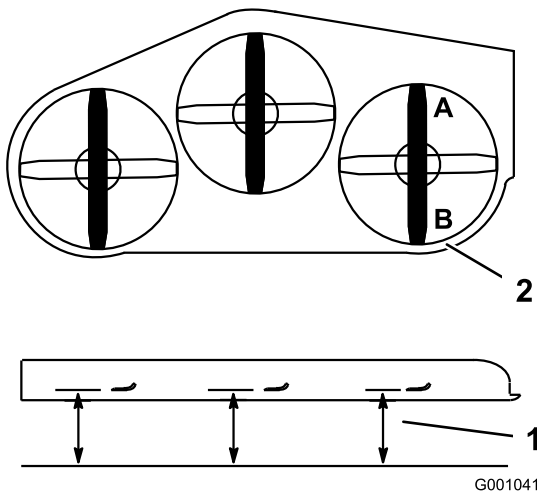

Figure 94

G001041

g001041

1. Measure here from blade
2. Measure at A and B to hard surface

2. Measure the right blade at the **A** location, from a level surface to the cutting edge of the blade tip (Figure 94).
3. Record this measurement.
4. Measure the right blade at the **B** location, from a level surface to the cutting edge of the blade tip (Figure 94).
5. Record this measurement.
6. The mower blade should be 6 to 10 mm (1/4 to 3/8 inch) lower at position **A** than at position **B** (Figure 94). If it is not correct, proceed to the following steps.

Note: Both of the front swivels need to be adjusted the same amount to maintain equal chain tension.

7. Loosen the front swivel jam nuts, at the front of the right and left swivels, approximately 13 mm (1/2 inch) (Figure 93).
8. Adjust the lift nuts on both the left and the right side of the machine to achieve 6 to 10 mm (1/4 to 3/8 inch) lower in front at **A** than in the rear at **B** (Figure 93).
9. Tighten both swivel jam nuts against the front swivel to lock the height.
10. Check to make sure that there is equal tension on the chains and adjust again if needed.

Adjusting the Compression Spring

1. Raise the mower lift lever to the transport position.
2. Check the distance between the 2 large washers, it needs to be 28.2 cm (11-1/8 inches) for 52-inch mower decks, 26.7 cm (10-1/2 inches) for 60-inch mower decks, or 29.2 cm (11-1/2 inches) for 72-inch mower decks (Figure 95).

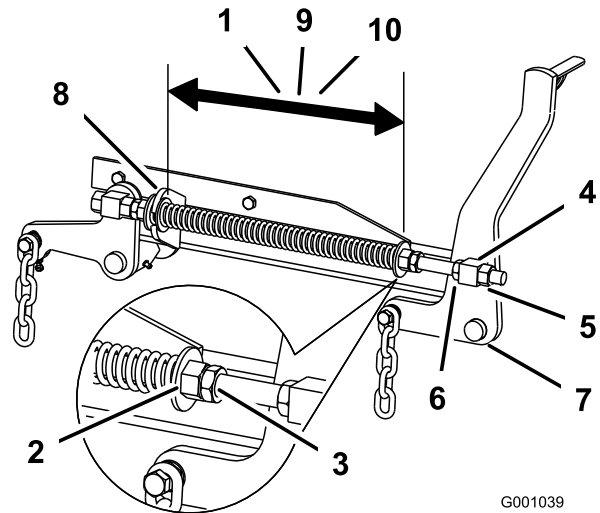

Figure 95

G001039

g002479

- | | |
|--|---|
| 1. 28.2 cm (11-1/8 inches) between the large washers for 52-inch mower decks | 6. Lift nut |
| 2. Front nut | 7. Front-support arm |
| 3. Spring-jam nut | 8. Large washer |
| 4. Front swivel | 9. 26.7 cm (10-1/2 inches) between the large washers for 60-inch mower decks |
| 5. Swivel jam nut | 10. 29.2 cm (11-1/2 inches) between the large washers for 72-inch mower decks |

3. Adjust this distance, by loosening the spring-jam nut and turning the nut in front of each spring (Figure 95).

Note: Turning the nut clockwise shortens the spring; counter-clockwise lengthens the spring.

4. Lock the nut into position by tightening the spring-jam nut (Figure 95).

Servicing the Cutting Blades

Maintain sharp blades throughout the cutting season because sharp blades cut cleanly without tearing or shredding the grass blades. Tearing and shredding turns grass brown at the edges, which slows growth and increases the chance of disease.

Check the cutter blades daily for sharpness, and for any wear or damage. File down any nicks and sharpen the blades as necessary. If a blade is damaged or worn, replace it immediately with a genuine Toro replacement blade. For convenient sharpening and replacement, you may want to keep extra blades on hand.

Blade Safety

A worn or damaged blade can break, and a piece of the blade could be thrown at you or bystanders, resulting in serious personal injury or death. Trying to repair a damaged blade may result in discontinued safety certification of the product.

- Inspect the blade periodically for wear or damage.
- Use care when checking the blades. Wrap the blades or wear gloves, and use caution when servicing the blades. Only replace or sharpen the blades; never straighten or weld them.
- On multi-bladed machines, take care as rotating 1 blade can cause other blades to rotate.

Before Inspecting or Servicing the Blades

1. Park the machine on a level surface, disengage the blade-control switch (PTO), and engage the parking brake.
2. Shut off the engine, disconnect the battery, and remove the key.

Inspecting the Blades

Service Interval: Before each use or daily

1. Inspect the cutting edges (Figure 96).
2. If the edges are not sharp or have nicks, remove and sharpen the blade; refer to [Removing the Blades \(page 72\)](#) and [Sharpening the Blades \(page 72\)](#).
3. Inspect the blades, especially in the curved area.
4. If you notice any cracks, wear, or a slot forming in this area, immediately install a new blade (Figure 96).

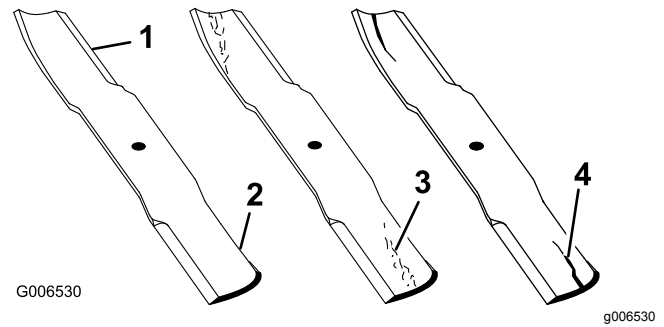

Figure 96

1. Cutting edge
2. Curved area
3. Wear/slot forming
4. Crack

Checking for Bent Blades

1. Disengage the blade-control switch (PTO), move the motion-control levers to the NEUTRAL-LOCK position, and engage the parking brake.
2. Shut off the engine, remove the key, and wait for all moving parts to stop before leaving the operating position.
3. Rotate the blades until the ends face forward and backward.
4. Measure from a level surface to the cutting edge, position A, of the blades (Figure 97).

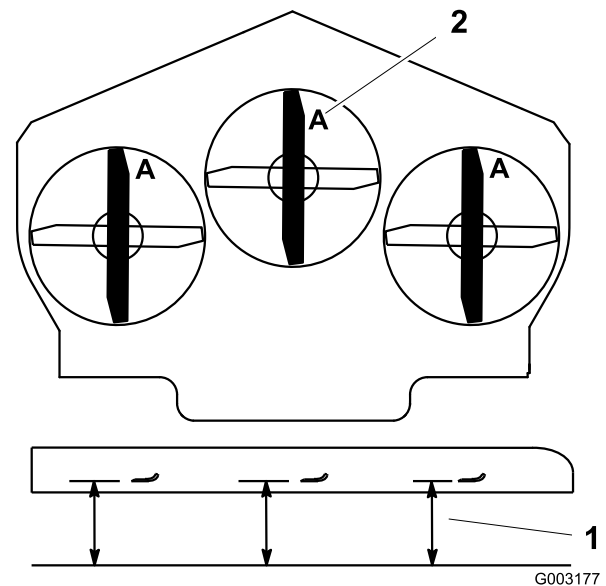

Figure 97

1. Measure here from blade to hard surface
2. Position A

5. Rotate the opposite ends of the blades forward.
6. Measure from a level surface to the cutting edge of the blades at the same position as in step 4 above.

Note: The difference between the dimensions obtained in steps 4 and 6 must not exceed 3 mm (1/8 inch).

Note: If this dimension exceeds 3 mm (1/8 inch), the blade is bent and must be replaced.

⚠ WARNING

A blade that is bent or damaged could break apart and could seriously injure or kill you or bystanders.

- Always replace a bent or damaged blade with a new blade.
- Do not file or create sharp notches in the edges or surfaces of the blade.

Removing the Blades

Blades must be replaced if a solid object is hit, if the blade is out of balance, or if the blade is bent. To ensure optimum performance and continued safety conformance of the machine, use genuine Toro replacement blades. Replacement blades made by other manufacturers may result in nonconformance with safety standards.

1. Hold the blade end using a rag or a thickly-padded glove.
2. Remove the blade bolt, the curved washer, and the blade from the spindle shaft (Figure 98).

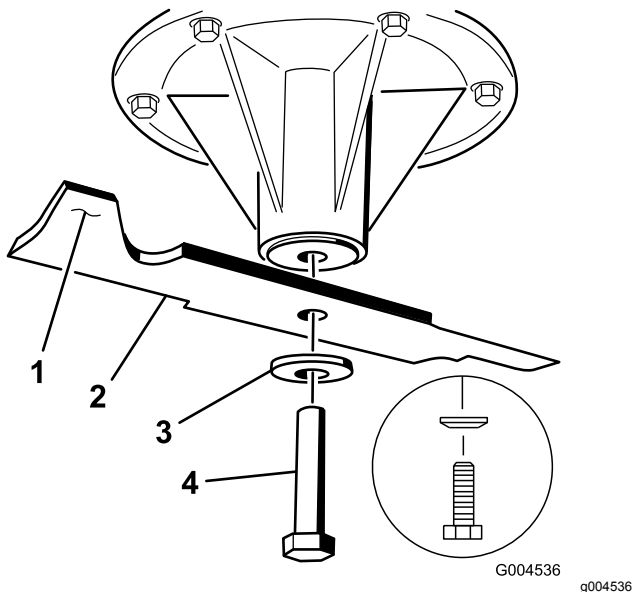

Figure 98

1. Sail area of the blade
2. Blade
3. Curved washer
4. Blade bolt

Sharpening the Blades

1. Use a file to sharpen the cutting edge at both ends of the blade (Figure 99).

Note: Maintain the original angle.

Note: The blade retains its balance if the same amount of material is removed from both cutting edges.

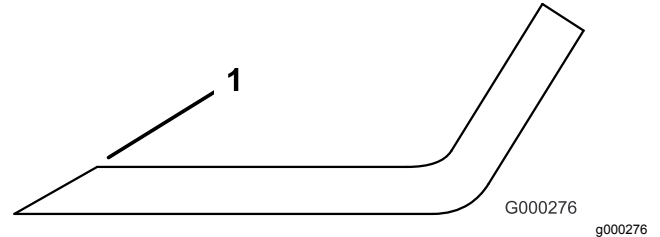

Figure 99

1. Sharpen at original angle.

2. Check the balance of the blade by putting it on a blade balancer (Figure 100).

Note: If the blade stays in a horizontal position, the blade is balanced and can be used.

Note: If the blade is not balanced, file some metal off the end of the sail area only (Figure 99).

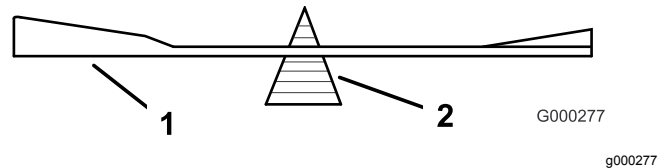

Figure 100

1. Blade
2. Balancer

3. Repeat this procedure until the blade is balanced.

Installing the Blades

1. Install the blade onto the spindle shaft (Figure 101).

Important: The curved part of the blade must point upward toward the inside of the mower to ensure proper cutting.

2. Install the spring disk and blade bolt (Figure 101).

Note: The spring-disk cone must be installed toward the bolt head (Figure 101).

3. Torque the blade bolt to 115 to 150 N·m (85 to 110 ft·lb).

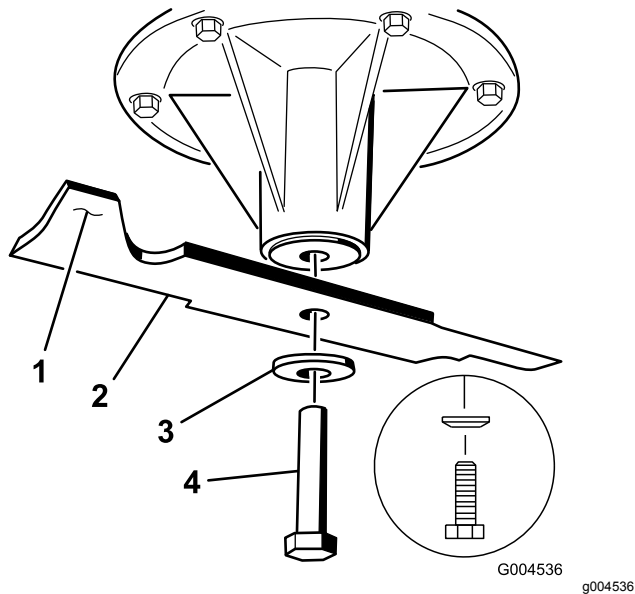

Figure 101

- | | |
|---------------------------|----------------|
| 1. Sail area of the blade | 3. Spring disk |
| 2. Blade | 4. Blade bolt |

Replacing the Grass Deflector

⚠ WARNING

An uncovered discharge opening could allow the lawn mower to throw objects toward you or bystanders, resulting in serious injury. Also, contact with the blade could occur.

- Never operate the lawn mower unless you install a cover plate, a mulch plate, or a grass chute and catcher.
- Make sure that the grass deflector is in the down position.

1. Remove the locknut, bolt, spring and spacer holding the deflector to the pivot brackets (Figure 102).
2. Remove the damaged or worn grass deflector.
3. Place the spacer and spring onto the grass deflector. Place the L end of the spring behind the deck edge.

Note: Make sure that the L end of the spring is installed behind the deck edge before installing the bolt as shown in Figure 102

4. Install the bolt and nut.
5. Place the J-hook end of the spring around the grass deflector (Figure 102).

Important: The grass deflector must be able to lower into position. Lift the deflector up to test that it lowers into the full-down position.

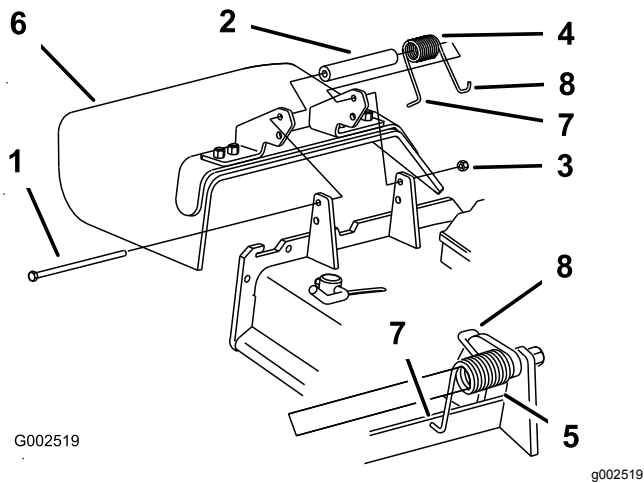

Figure 102

- | | |
|------------|---|
| 1. Bolt | 5. Spring installed |
| 2. Spacer | 6. Grass deflector |
| 3. Locknut | 7. L-end of spring, place behind deck edge before installing bolt |
| 4. Spring | 8. J-hook end of spring |

Cleaning

Cleaning under the Mower

Service Interval: Before each use or daily

Remove the grass buildup under the mower daily.

1. Disengage the blade-control switch (PTO), move the motion-control levers to the NEUTRAL-LOCK position, and engage the parking brake.
2. Shut off the engine, remove the key, and wait for all moving parts to stop before leaving the operating position.
3. Raise the mower to the transport position.

Waste Disposal

Engine oil, batteries, hydraulic fluid, and engine coolant are pollutants to the environment. Dispose of these according to your state and local regulations.

Storage

Cleaning and Storage

1. Disengage the blade-control switch (PTO), engage the parking brake, turn the ignition key to the OFF position, and remove the key.
2. Remove grass clippings, dirt, and grime from the external parts of the entire machine, especially the engine and hydraulic system. Clean dirt and chaff from the outside of the engine cylinder head fins and blower housing.

Important: You can wash the machine with mild detergent and water. Do not pressure wash the machine. Avoid excessive use of water, especially near the control panel, engine, hydraulic pumps, and motors.

3. Check the brake; refer to [Brake Maintenance \(page 56\)](#).
Service the air cleaner; refer to [Servicing the Air Cleaner \(page 41\)](#).
Grease the machine; refer to [Lubrication \(page 38\)](#).
4. Change the crankcase oil; refer to [Servicing the Engine Oil \(page 42\)](#).
Check the tire pressure; refer to [Checking the Tire Pressure \(page 51\)](#).
Change the hydraulic filter; refer to [Replacing the Hydraulic Filter and Fluid \(page 64\)](#).
Charge the battery; refer to [Charging the Battery \(page 49\)](#).
Scrape any heavy buildup of grass and dirt from the underside of the mower, then wash the mower with a garden hose.

Note: Run the machine with the blade-control switch (PTO) engaged and the engine at high idle for 2 to 5 minutes after washing.

5. Check the condition of the blades; refer to [Inspecting the Blades \(page 71\)](#).
Prepare the machine for storage when non-use occurs over 30 days. Prepare the machine for storage as follows:
 - A. Run the engine to distribute conditioned fuel through the fuel system (5 minutes).
 - B. Shut off the engine, allow it to cool, and drain the fuel tank; refer to [Servicing the Fuel Tank \(page 47\)](#).
Note: Start the engine and run it until it shuts off.
 - C. Dispose of fuel properly. Recycle as per local codes.

Important: Do not store stabilizer/conditioned fuel over 90 days.

6. Check and tighten all bolts, nuts, and screws. Repair or replace any part that is damaged.
7. Paint all scratched or bare metal surfaces. Paint is available from your Authorized Service Dealer.
8. Store the machine in a clean, dry garage or storage area. Remove the key from the ignition switch and keep it out of reach of children or other unauthorized users. Cover the machine to protect it and keep it clean.

Troubleshooting

Problem	Possible Cause	Corrective Action
The starter does not crank.	<ol style="list-style-type: none"> 1. The blade-control switch (PTO) is engaged. 2. The parking brake is not engaged. 3. The drive levers are not in the NEUTRAL-LOCK position. 4. The operator is not seated. 5. The battery is dead. 6. The electrical connections are corroded or loose. 7. The fuse is blown. 8. The relay or switch is broken. 	<ol style="list-style-type: none"> 1. Move the blade-control switch (PTO) to disengaged. 2. Engage the parking brake. 3. Ensure that the drive levers are in the NEUTRAL-LOCK position. 4. Sit on the seat. 5. Charge the battery. 6. Check the electrical connections for good contact. 7. Replace the fuse. 8. Contact an Authorized Service Dealer.
The engine does not start, starts hard, or fails to keep running	<ol style="list-style-type: none"> 1. The fuel tank is empty. 2. The fuel-shutoff valve is closed. 3. The oil level in the crankcase is low. 4. The throttle is not in the correct position. 5. There is dirt in fuel filter. 6. There is dirt, water, or stale fuel is in the fuel system. 7. The air cleaner is dirty. 8. The seat switch is not functioning properly. 9. The electrical connections are corroded, loose or faulty. 10. The relay or switch is broken. 	<ol style="list-style-type: none"> 1. Fill the fuel tank. 2. Open the fuel-shutoff valve. 3. Add oil to the crankcase. 4. Be sure that the throttle control is midway between the SLOW and FAST positions. 5. Replace the fuel filter. 6. Contact an Authorized Service Dealer. 7. Clean or replace the air-cleaner element. 8. Check the seat switch indicator. Replace the seat if needed. 9. Check the electrical connections for good contact. Clean the connector terminals thoroughly with electrical contact cleaner, apply dielectric grease, and connect. 10. Contact an Authorized Service Dealer.
The engine loses power.	<ol style="list-style-type: none"> 1. The engine load is excessive. 2. The air cleaner is dirty. 3. The oil level in the crankcase is low. 4. The cooling fins and air passages above the engine are plugged. 5. The vent hole in the fuel cap is plugged. 6. There is dirt in the fuel filter. 7. There is dirt, water, or stale fuel is in the fuel system. 	<ol style="list-style-type: none"> 1. Reduce the ground speed. 2. Clean the air-cleaner element. 3. Add oil to the crankcase. 4. Remove the obstruction from the cooling fins and air passages. 5. Clean or replace the fuel cap. 6. Replace the fuel filter. 7. Contact an Authorized Service Dealer.
The engine overheats.	<ol style="list-style-type: none"> 1. The engine load is excessive. 2. The oil level in the crankcase is low. 3. The cooling fins and air passages above the engine are plugged. 	<ol style="list-style-type: none"> 1. Reduce the ground speed. 2. Add oil to the crankcase. 3. Remove the obstruction from the cooling fins and air passages.
The machine does not drive.	<ol style="list-style-type: none"> 1. The by pass valves are not closed tight. 2. The pump belt is worn, loose or broken. 3. The pump belt is off a pulley. 4. The idler spring is broken or missing. 5. The hydraulic-fluid level is low or too hot. 	<ol style="list-style-type: none"> 1. Tighten the by pass valves. 2. Change the belt. 3. Change the belt. 4. Replace the spring. 5. Add hydraulic fluid to reservoirs or let it cool down.

Problem	Possible Cause	Corrective Action
There is abnormal vibration.	<ol style="list-style-type: none"> 1. The cutting blade(s) is/are bent or unbalanced. 2. The blade mounting bolt is loose. 3. The engine mounting bolts are loose. 4. The engine pulley, idler pulley, or blade pulley is loose. 5. The engine pulley is damaged. 6. The blade spindle is bent. 7. The motor mount is loose or worn. 	<ol style="list-style-type: none"> 1. Install new cutting blade(s). 2. Tighten the blade mounting bolt. 3. Tighten the engine mounting bolts. 4. Tighten the appropriate pulley. 5. Contact an Authorized Service Dealer. 6. Contact an Authorized Service Dealer. 7. Contact an Authorized Service Dealer.
Mowing is resulting in uneven cutting height.	<ol style="list-style-type: none"> 1. The blade(s) is/are not sharp. 2. The cutting blade(s) is/are bent. 3. The mower deck is not level. 4. The underside of mower is dirty. 5. The tire pressure is not correct. 6. The blade spindle bent. 	<ol style="list-style-type: none"> 1. Sharpen the blade(s). 2. Install new cutting blade(s). 3. Level the mower deck from side-to-side and front-to-rear. 4. Clean the underside of the mower. 5. Adjust the tire pressure. 6. Contact an Authorized Service Dealer.
The blades do not rotate.	<ol style="list-style-type: none"> 1. The mower deck belt is worn, loose or broken. 2. The mower deck belt is off pulley. 3. The pump drive belt is worn, loose or broken. 4. The idler spring is broken or missing. 	<ol style="list-style-type: none"> 1. Install a new deck belt. 2. Install the mower deck pulley and check the idler pulley, idler arm, and spring for correct position and function. 3. Check the belt tension or install a new belt. 4. Replace the spring.

Schematics

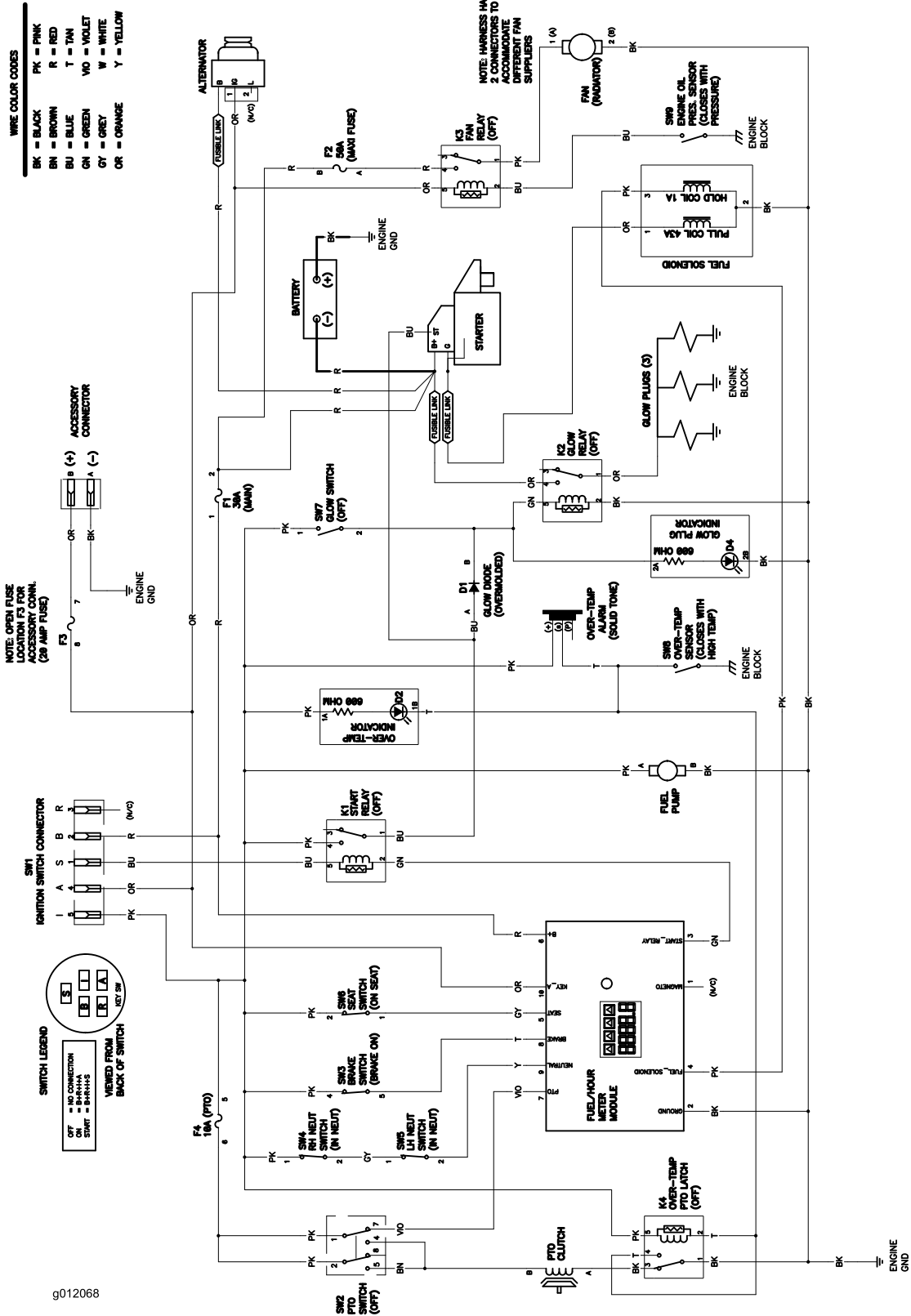

g012068

Wire Diagram (Rev. A)

g012068

Notes:



The Toro Warranty

A Limited Warranty (see warranty periods below)

Landscape Contractor Equipment (LCE)
Riding Product

Conditions and Products Covered

The Toro Company and its affiliate, Toro Warranty Company, pursuant to an agreement between them, jointly promise to repair the Toro Products listed below if defective in materials or workmanship.

The following time periods apply from the original date of purchase:

Products	Warranty Period
GrandStand® Mowers • Engines ³	5 years or 1,200 hours ² 3 years
Z Master® 3000 Series Mowers • Engines ³	5 years or 1,250 hours ² 3 years
Z Master® 5000 Series Mowers • Engines ³	5 years or 1,250 hours ² 3 years
Z Master® 6000 Series Mowers • Engines ³	5 years or 1,250 hours ² 3 years
Z Master®7000 Series Mowers • Engines ³	4 years or 1,200 hours ² 2 years
Z Master®8000 Series Mowers • Engines ³	2 years 3 years
TITAN HD 1500 Series • Engines	4 years or 500 Hours ² Toro – 4 years or 500 hours
TITAN HD 2000 Series • Engines ³	4 years or 750 Hours ² Kohler – 3 years
TITAN HD 2500 Series • Engines ³	4 years or 1000 Hours ² Kawasaki – 3 years
All Mowers	
• Battery	90 days Parts and Labor 1 year Parts only
• Belts and Tires	90 days
• Attachments	1 year

¹Residential use means use of the product on the same lot as your home. Use at more than one location is considered commercial use and the commercial warranty would apply.

²Whichever occurs first.

³Some engines used on Toro Products are warranted by the engine manufacturer.

Owner Responsibilities

You must maintain your Toro Product by following the maintenance procedures described in the *Operator's Manual*. Such routine maintenance, whether performed by a dealer or by you, is at your expense.

Instructions for Obtaining Warranty Service

If you think that your Toro Product contains a defect in materials or workmanship, follow this procedure:

- Contact any Authorized Toro Service Dealer to arrange service at their dealership. To locate a dealer convenient to you, access our web site at www.Toro.com. You may also call the numbers listed in item #3 to use the 24-hour Toro Dealer locator system.
- Bring the product and your proof of purchase (sales receipt) to the Service Dealer. The dealer will diagnose the problem and determine if it is covered under warranty.

Countries Other than the United States or Canada

Customers who have purchased Toro products outside the United States or Canada should contact their Toro Distributor (Dealer) to obtain guarantee policies for your country, province, or state. If for any reason you are dissatisfied with your Distributor's service or have difficulty obtaining guarantee information, contact the Toro importer. If all other remedies fail, you may contact us at Toro Warranty Company.

Australian Consumer Law: Australian customers will find details relating to the Australian Consumer Law either inside the box or at your local Toro Dealer.

- If for any reason you are dissatisfied with the Service Dealer's analysis or with the assistance provided, contact us at:

Toro Warranty Company
Customer Care Department, RLC Division
8111 Lyndale Avenue South
Bloomington, MN 55420-1196
888-865-5676 (U.S. Customers)
888-865-5691 (Canada customers)

Items and Conditions Not Covered

There is no other express warranty except for special emission system coverage and engine warranty coverage on some products. This express warranty does not cover the following:

- Cost of regular maintenance service or parts, such as filters, fuel, lubricants, oil changes, spark plugs, air filters, blade sharpening or worn blades, cable/linkage adjustments, or brake and clutch adjustments
- Components failing due to normal wear
- Any product or part which has been altered, misused, neglected, or requires replacement or repair due to accidents or lack of proper maintenance
- Pickup and delivery charges
- Repairs or attempted repairs by anyone other than an Authorized Toro Service Dealer
- Repairs necessary due to failure to follow recommended fuel procedure (consult *Operator's Manual* for more details)
 - Removing contaminants from the fuel system is not covered
 - Use of old fuel (more than one month old) or fuel which contains more than 10% ethanol or more than 15% MTBE
 - Failure to drain the fuel system prior to any period of non-use over one month

General Conditions

All repairs covered by these warranties must be performed by an Authorized Toro Service Dealer using Toro approved replacement parts.

Neither The Toro Company nor Toro Warranty Company is liable for indirect, incidental or consequential damages in connection with the use of the Toro Products covered by this warranty, including any cost or expense of providing substitute equipment or service during reasonable periods of malfunction or non-use pending completion of repairs under this warranty.

All implied warranties of merchantability (that the product is fit for ordinary use) and fitness for use (that the product is fit for a particular purpose) are limited to the duration of the express warranty.

Some states do not allow exclusions of incidental or consequential damages, or limitations on how long an implied warranty lasts, so the above exclusions and limitations may not apply to you.

This warranty gives you specific legal rights, and you may also have other rights which vary from state to state.