

Rear Guard Kit

For Diesel Models

Kit No. 135-3445

Installation Instructions

For Serial Nos. 402,082,300 & Higher

Safety Alert Symbol

This Safety Alert Symbol (Figure 1) is used both in this instruction sheet and on the machine to identify important safety messages which must be followed to avoid accidents

This symbol means: **ATTENTION! BECOME ALERT! YOUR SAFETY IS INVOLVED!**



g000502

Figure 1

Safety Alert Symbol

The safety alert symbol appears above information which alerts you to unsafe actions or situations and will be followed by the word **DANGER**, **WARNING**, or **CAUTION**.

DANGER: White lettering / Red background. Indicates an imminently hazardous situation which, if not avoided, **Will** result in death or serious injury.

WARNING: Black lettering / Orange background. Indicates a potentially hazardous situation which, if not avoided, **Could** result in death or serious injury.

CAUTION: Black lettering / Yellow background. Indicates a potentially hazardous situation which, if not avoided, **May** result in minor or moderate injury.

This manual uses two other words to highlight information. **Important** calls attention to special mechanical information and **Note** emphasizes general information worthy of special attention.

⚠ WARNING

While maintenance or adjustments are being made, someone could start the engine. Accidental starting of the engine could seriously injure you or other bystanders.

Remove the key from the ignition switch, engage parking brake, and pull the wire(s) off the spark plug(s) before you do any maintenance. Also push the wire(s) aside so it does not accidentally contact the spark plug(s).

Note: Determine the left and right sides of the machine from the normal operating position.

Note: Park the unit on a level surface. Make sure all moving parts have stopped, parking brake is engaged, the key has been removed, and the spark plug wire has been disconnected. Allow unit to cool before starting these instructions.



Loose Parts

Use the chart below to verify that all parts have been shipped.

Item	Part No.	Description	Qty
1	135-3446-03	Guard-Rear	1
2	135-3454-03	Bracket-Mount, Guard	1
3	131-4036	Decal-Max Drawbar Pull	1
4	109-6658	Nut-Nyloc 3/8-16 Flg	8
5	66-2920	Washer-Friction	2

Item	Part No.	Description	Qty
6	115-1485	Washer-Plain	5
7	3231-26	Bolt-Carriage 3/8-16 x 1 1/2	2
8	3234-41	Screw-HHF 3/8-16 x 3 1/4	2
9	3234-39	Screw-HFH 3/8-16 x 2 1/2	4
10	116-0104	Asm-Spring Pin	2

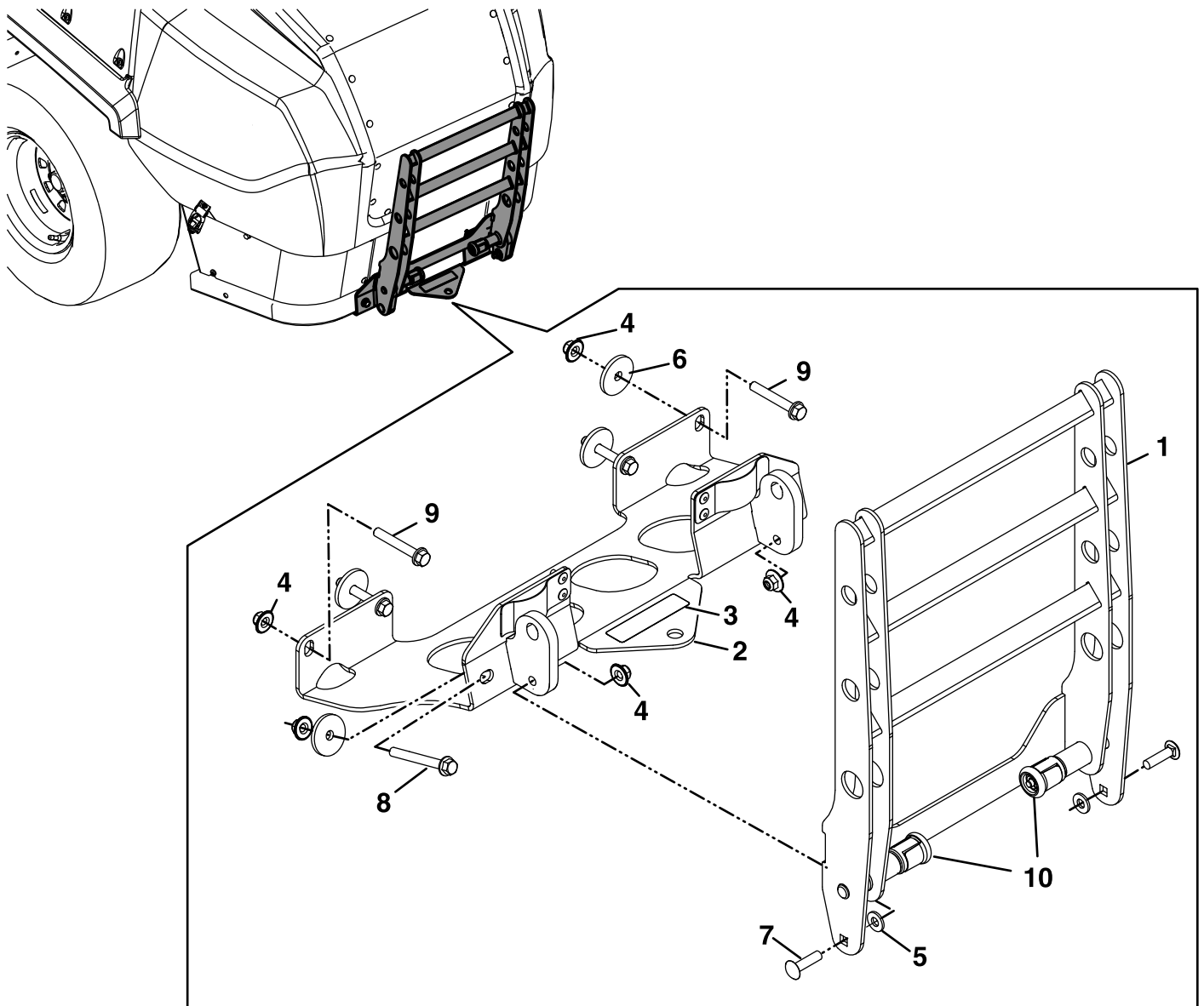

Figure 2

g253193

Installation Instructions

⚠ CAUTION

Components around engine will be hot if the machine has been running. Touching hot components can cause burns.

- **Allow the machine to cool before performing maintenance.**
 - **Do not touch engine components when hot.**
1. Make sure the machine is on a level surface and the PTO is disengaged.
 2. Stop engine, wait for all moving parts to stop, engage the parking brake remove the key, and disconnect the negative battery cable.
 3. Mount the guard mount bracket to the rear frame using the hardware shown in .
 4. Attach the rear guard to the guard mount bracket using two 3/8-16 x 1 1/2 inch carriage bolts, washers, and 3/8 inch nyloc flanged nuts as shown in .

Towing Information

1. Do not attach towed equipment except at the hitch point.
2. Follow the manufacturer's recommendation for weight limits, as shown in [Figure 3](#), for towed equipment and towing on slopes.



g028472

Figure 3

1. Tow or pull weights that are less than or equal to 36 kg (80 lbs).
 2. Read the Operator's Manual.
-
3. Never allow children or others in or on towed equipment.
 4. On slopes, the weight of the towed equipment may cause loss of traction and loss of control.
 5. Travel slowly and allow extra distance to stop.