



# TimeMaster 30in Lawn Mower

Model No. 21199—Serial No. 403600000 and Up

Model No. 21199HD—Serial No. 404314000 and Up

Model No. 21200—Serial No. 403600000 and Up

## Operator's Manual

# Introduction

This rotary-blade, walk-behind lawn mower is intended to be used by residential homeowners. It is designed primarily for cutting grass on well-maintained lawns on residential properties. It is not designed for cutting brush or for agricultural uses.

Read this information carefully to learn how to operate and maintain your product properly and to avoid injury and product damage. You are responsible for operating the product properly and safely.

You may contact Toro directly at [www.Toro.com](http://www.Toro.com) for product and accessory information, help finding a dealer, or to register your product.

Whenever you need service, genuine Toro parts, or additional information, contact an Authorized Service Dealer or Toro Customer Service and have the model and serial numbers of your product ready. [Figure 1](#) identifies the location of the model and serial numbers on the product. Write the product model and serial numbers in the space provided.

**Important:** With your mobile device, you can scan the QR code on the serial number decal (if equipped) to access warranty, parts, and other product information.



Figure 1

g226622

1. Model and serial number location

|                  |
|------------------|
| Model No. _____  |
| Serial No. _____ |

This manual identifies potential hazards and has safety messages identified by the safety-alert symbol ([Figure 2](#)), which signals a hazard that may cause

serious injury or death if you do not follow the recommended precautions.



Figure 2

Safety-alert symbol

g000502

This manual uses 2 words to highlight information. **Important** calls attention to special mechanical information and **Note** emphasizes general information worthy of special attention.

It is a violation of California Public Resource Code Section 4442 or 4443 to use or operate the engine on any forest-covered, brush-covered, or grass-covered land unless the engine is equipped with a spark arrester, as defined in Section 4442, maintained in effective working order or the engine is constructed, equipped, and maintained for the prevention of fire.

The enclosed *Engine Owner's Manual* is supplied for information regarding the US Environmental Protection Agency (EPA) and the California Emission Control Regulation of emission systems, maintenance, and warranty. Replacements may be ordered through the engine manufacturer.

**Gross or Net Torque:** The gross or net torque of this engine was laboratory rated by the engine manufacturer in accordance with the Society of Automotive Engineers (SAE) J1940 or J2723. As configured to meet safety, emission, and operating requirements, the actual engine torque on this class of mower will be significantly lower. Please refer to the engine manufacturer's information included with the machine.



## **⚠ WARNING**

### **CALIFORNIA**

#### **Proposition 65 Warning**

**The engine exhaust from this product contains chemicals known to the State of California to cause cancer, birth defects, or other reproductive harm.**

**Battery posts, terminals, and related accessories contain lead and lead compounds, chemicals known to the State of California to cause cancer and reproductive harm. Wash hands after handling.**

**Use of this product may cause exposure to chemicals known to the State of California to cause cancer, birth defects, or other reproductive harm.**

|   |    |
|---|----|
| After Operation .....                     | 22 |
| After Operation Safety .....              | 22 |
| Cleaning under the Machine .....          | 22 |
| Maintenance .....                         | 24 |
| Recommended Maintenance Schedule(s) ..... | 24 |
| Maintenance Safety .....                  | 24 |
| Preparing for Maintenance .....           | 24 |
| Servicing the Air Filter .....            | 25 |
| Changing the Engine Oil .....             | 25 |
| Charging the Battery .....                | 26 |
| Replacing the Fuse .....                  | 27 |
| Replacing the Battery .....               | 27 |
| Adjusting the Self-Propel Drive .....     | 28 |
| Servicing the Blade-Drive System .....    | 28 |
| Servicing the Blades .....                | 29 |
| Checking for Bent Blades .....            | 30 |
| Removing the Blades .....                 | 31 |
| Installing the Blades .....               | 31 |
| Storage .....                             | 32 |
| General Information .....                 | 32 |
| Preparing the Fuel System .....           | 32 |
| Preparing the Engine .....                | 33 |
| Removing the Machine from Storage .....   | 33 |

# Contents

|   |    |
|---|----|
| Introduction .....                          | 1  |
| Safety .....                                | 3  |
| General Safety .....                        | 3  |
| Safety and Instructional Decals .....       | 3  |
| Setup .....                                 | 6  |
| 1 Assembling and Unfolding the Handle ..... | 6  |
| 2 Installing the Blade-Control Bar .....    | 6  |
| 3 Filling the Engine with Oil .....         | 8  |
| 4 Assembling the Grass Bag .....            | 8  |
| 5 Charging the Battery .....                | 9  |
| Product Overview .....                      | 9  |
| Operation .....                             | 10 |
| Before Operation .....                      | 10 |
| Before Operation Safety .....               | 10 |
| Filling the Fuel Tank .....                 | 11 |
| Checking the Engine-Oil Level .....         | 12 |
| Adjusting the Handle Height .....           | 13 |
| Adjusting the Cutting Height .....          | 14 |
| During Operation .....                      | 14 |
| During Operation Safety .....               | 14 |
| Starting the Engine .....                   | 15 |
| Using the Self-Propel Drive .....           | 17 |
| Shutting Off the Engine .....               | 17 |
| Engaging the Blades .....                   | 18 |
| Disengaging the Blades .....                | 18 |
| Checking the Blade-Stop System              |    |
| Operation .....                             | 19 |
| Recycling the Clippings .....               | 19 |
| Bagging the Clippings .....                 | 20 |
| Side-Discharging the Clippings .....        | 20 |
| Operating Tips .....                        | 21 |

# Safety

This machine has been designed in accordance with ANSI B71.1-2012.

## General Safety

This product is capable of amputating hands and feet and of throwing objects. Always follow all safety instructions to avoid serious personal injury.

Using this product for purposes other than its intended use could prove dangerous to you and bystanders.

- Read, understand, and follow the instructions and warnings in this *Operator's Manual* and on the machine and attachments before starting the engine.
- Do not put your hands or feet near moving parts of or under the machine. Keep clear of any discharge opening.

- Do not operate the machine without all guards and other safety protective devices in place and working on the machine.
- Keep bystanders and children a safe distance away from the machine. Do not allow children to operate the machine. Allow only people who are responsible, trained, familiar with the instructions, and physically capable to operate the machine.
- Stop the machine and shut off the engine before servicing, fueling, or unclogging the machine.

Improperly using or maintaining this machine can result in injury. To reduce the potential for injury, comply with these safety instructions and always pay attention to the safety-alert symbol, which means Caution, Warning, or Danger—personal safety instruction. Failure to comply with these instructions may result in personal injury or death.

You can find additional safety information where needed throughout this manual.

## Safety and Instructional Decals



Safety decals and instructions are easily visible to the operator and are located near any area of potential danger. Replace any decal that is damaged or missing.

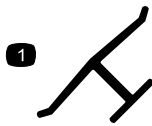

**Manufacturer's Mark**

decaloemmark

1. This mark indicates that the blade is identified as a part from the original machine manufacturer.



**94-8072**

decal94-8072

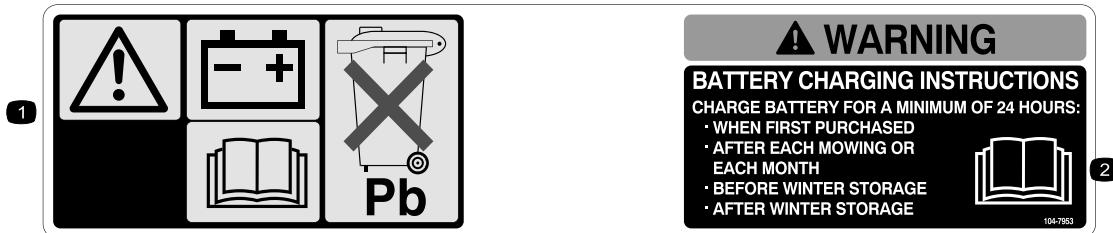

**104-7953**

Electric-Start Model Only

decal104-7953

1. Warning—read the *Operator's Manual* for information on charging the battery; contains lead; do not discard.
2. Read the *Operator's Manual*.

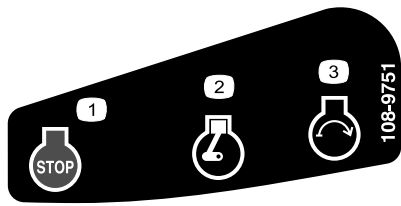

decal108-9751

**108-9751**

Electric-Start Model Only

1. Engine—stop (shut off)
2. Engine—run
3. Engine—start

**⚠ WARNING:** Cancer and Reproductive Harm - [www.P65Warnings.ca.gov](http://www.P65Warnings.ca.gov).  
For more information, please visit [www.ticoCProp65.com](http://www.ticoCProp65.com)  
**CALIFORNIA SPARK ARRESTER WARNING**  
Operation of this equipment may create sparks that can start fires around dry vegetation. A spark arrester may be required. The operator should contact local fire agencies for laws or regulations relating to fire prevention requirements.

decal133-8062

**133-8062**



decal120-9570

**120-9570**

1. Warning—stay away from moving parts; keep all guards and shields in place.

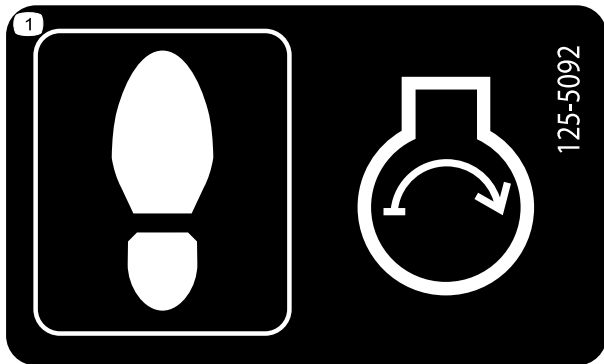

decal125-5092

**125-5092**

1. Step on the mower housing to start the engine.

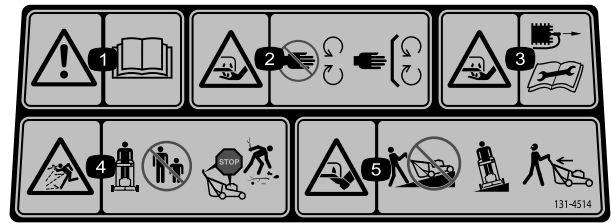

decal131-4514b

**131-4514**

1. Warning—read the *Operator's Manual*.
2. Cutting/dismemberment hazard of hand or foot, mower blade—stay away from moving parts; keep all guards and shields in place.
3. Cutting/dismemberment hazard of hand or foot, mower blade—disconnect the spark-plug wire and read the instructions before servicing or performing maintenance.
4. Thrown object hazard—keep bystanders a safe distance away from the machine; shut off the engine before leaving the operating position; pick up any debris before mowing.
5. Cutting/dismemberment hazard of hand or foot, mower blade—do not operate up and down slopes; operate side to side on slopes; look behind you when backing up.

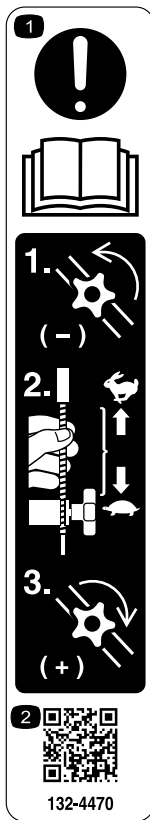

decal132-4470

### 132-4470

#### Traction Adjustment

1. Attention; read the *Operator's Manual*—1) Loosen the knob by turning it counterclockwise; 2) Pull the cable(s) away from the engine to decrease the traction, or push the cable(s) toward the engine to increase the traction; 3) Tighten the knob by turning it clockwise.
  2. Scan the QR code for more information on traction adjustment.
-

# Setup

**Important:** Remove and discard the protective plastic sheet that covers the engine and any other plastic or wrapping on the machine.

**Important:** To prevent accidental starting, do not insert the key into the electric-start ignition (if equipped) until you are ready to start the engine.

1

## Assembling and Unfolding the Handle

No Parts Required

### Procedure

#### **⚠ WARNING**

Assembling and unfolding the handle improperly can damage the cables, causing an unsafe operating condition.

- Do not damage the cables when unfolding the handle.
- If a cable is damaged, contact an Authorized Service Dealer.

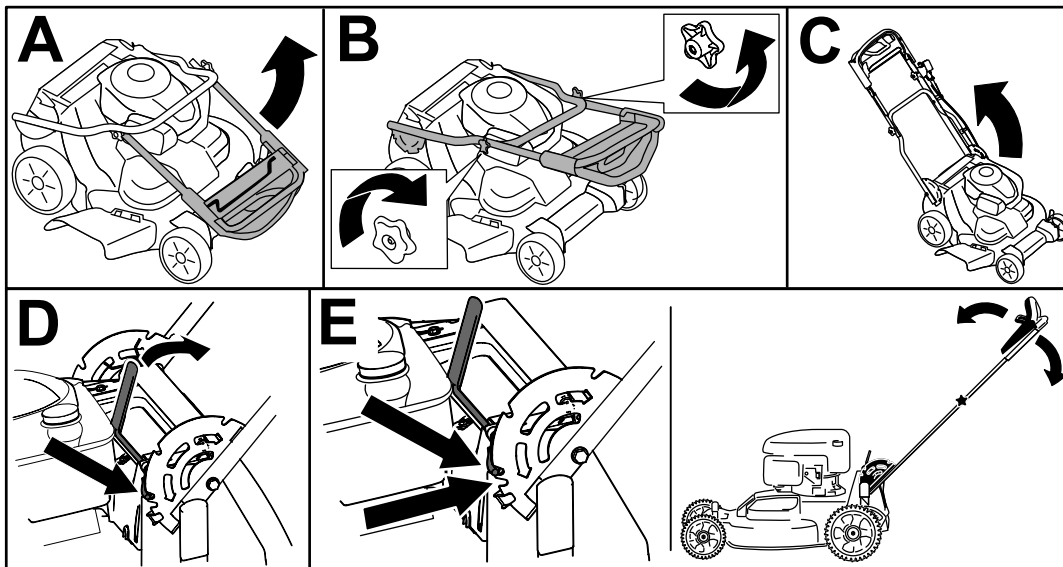

Figure 3

g224528

# 2

## Installing the Blade-Control Bar

No Parts Required

### Procedure

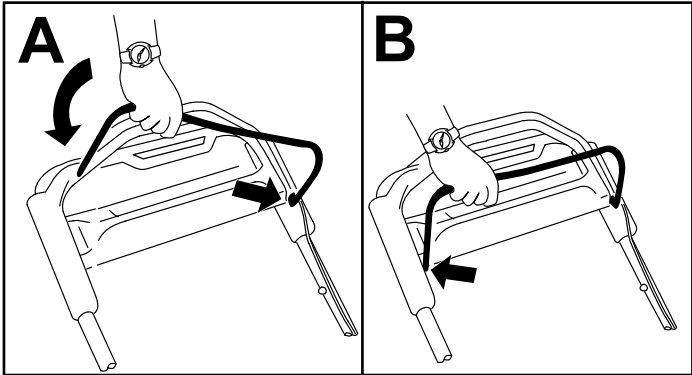

Figure 4

g225133

# 3

## Filling the Engine with Oil

No Parts Required

### Procedure

**Important:** Your machine does not come with oil in the engine, but it does come with a bottle of oil. Before starting the engine, fill the engine with oil.

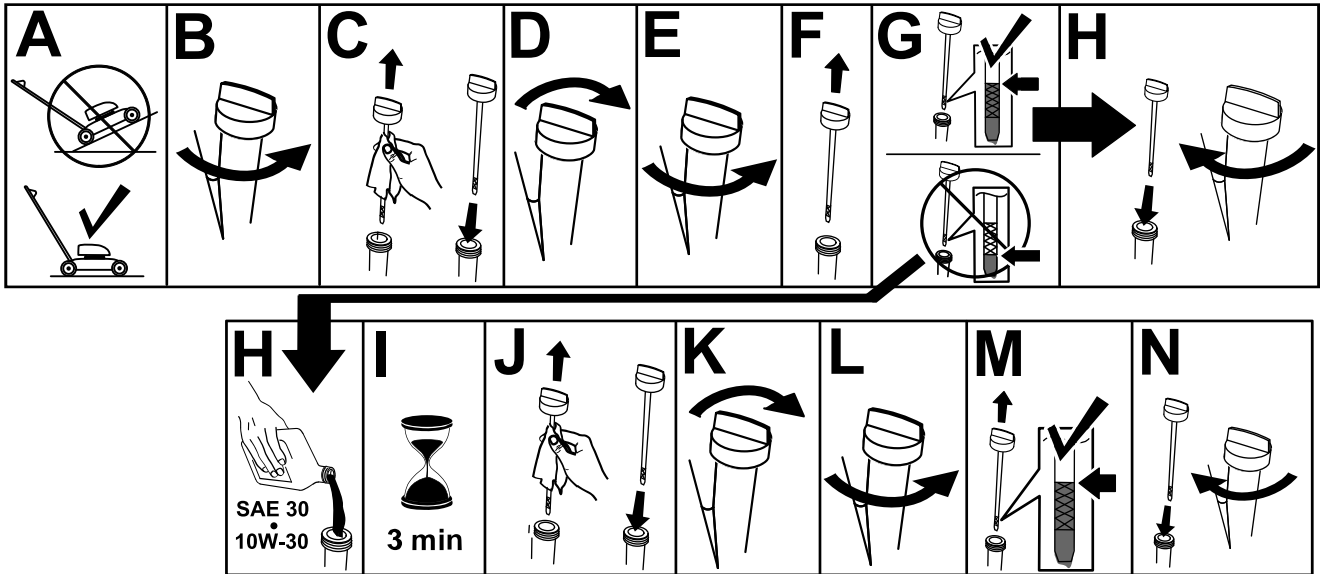

Figure 5

g222533

# 4

## Assembling the Grass Bag

No Parts Required

### Procedure

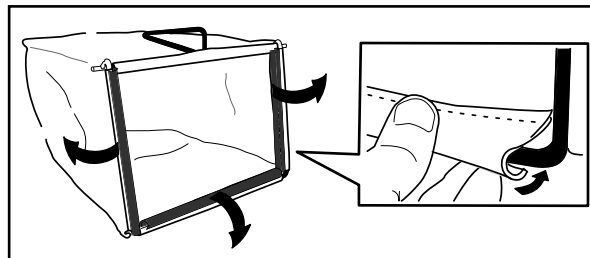

Figure 6

g230447



# 5

## Charging the Battery

No Parts Required

### Procedure

Electric-Start Model Only

Refer to [Charging the Battery](#) (page 26).

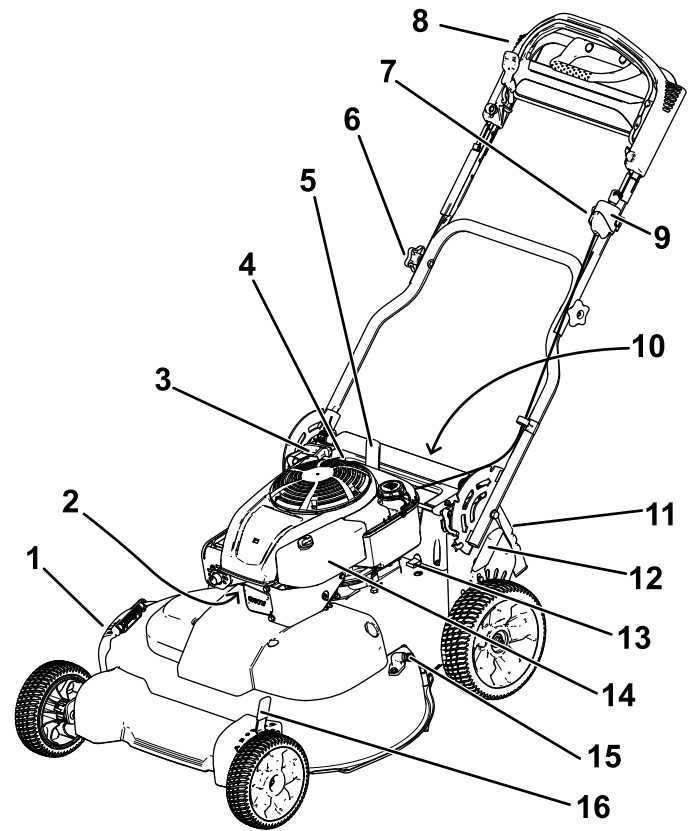

g191969

Figure 7

- |  |   |
|--|---|
| 1. Side-discharge deflector                  | 9. Ignition switch (electric-start model only) or toggle switch (standard model only) |
| 2. Spark plug                                | 10. Battery (electric-start model only; not shown)                                    |
| 3. Recoil-start handle                       | 11. Rear door   |
| 4. Oil fill/dipstick                         | 12. Rear cutting-height lever   |
| 5. Handle-lock lever                         | 13. Fuse  |
| 6. Handle knob (2)                           | 14. Air filter  |
| 7. Adjustment knob for the self-propel drive | 15. Washout port  |
| 8. Upper handle                              | 16. Front cutting-height lever  |

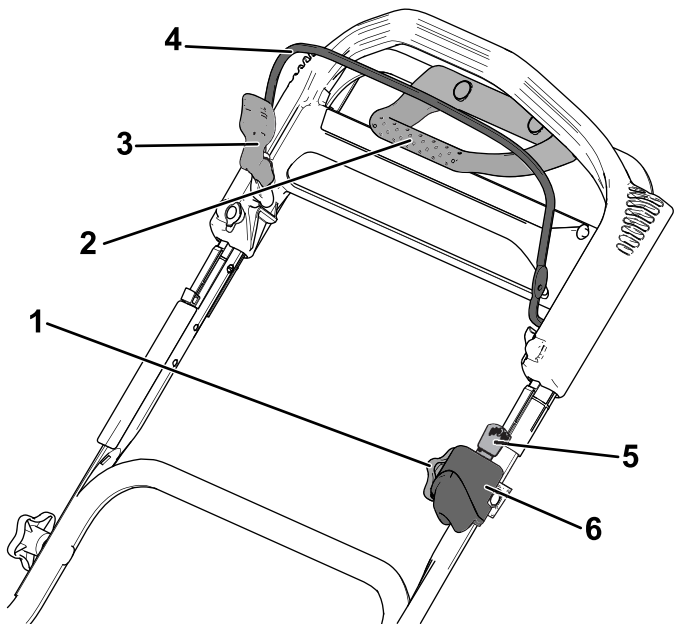

g191981

**Figure 8**  
Upper handle

- |  |   |
|--|---|
| 1. Adjustment knob for the self-propel drive | 4. Blade-control bar  |
| 2. Traction-assist handle                    | 5. Ignition key (electric-start model only)   |
| 3. Blade-control-bar lock                    | 6. Ignition switch (electric-start model only) or toggle switch (standard model only) |

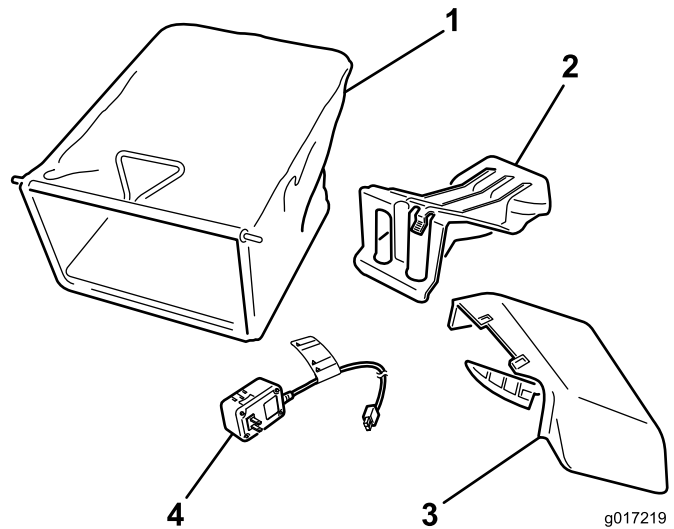

g017219  
g017219

**Figure 9**

- |                                    |  |
|------------------------------------|--|
| 1. Grass bag                       | 3. Side-discharge chute                        |
| 2. Rear-discharge plug (installed) | 4. Battery charger (electric-start model only) |

# Operation

**Note:** Determine the left and right sides of the machine from the normal operating position.

## Before Operation

### Before Operation Safety

#### General Safety

- Become familiar with the safe operation of the equipment, operator controls, and safety signs.
- Check that all guards and safety devices, such as deflectors and/or grass catcher, are in place and working properly.
- Always inspect the machine to ensure that the blades, blade bolts, and cutting assembly are not worn or damaged.
- Inspect the area where you will use the machine, and remove all objects that could interfere with the operation of the machine or that the machine could throw.
- Adjusting the cutting height may bring you into contact with the moving blade, causing serious injury.
  - Shut off the engine, remove the ignition key (electric-start model only), and wait for all moving parts to stop.
  - Do not put your fingers under the housing when adjusting the cutting height.

#### Fuel Safety

- Fuel is extremely flammable and highly explosive. A fire or explosion from fuel can burn you and others and can damage property.
  - To prevent a static charge from igniting the fuel, place the container and/or machine directly on the ground before filling, not in a vehicle or on an object.
  - Fill the fuel tank outdoors, in an open area, when the engine is cold. Wipe up any fuel that spills.
  - Do not handle fuel when smoking or around an open flame or sparks.
  - Do not remove the fuel cap or add fuel to the tank while the engine is running or hot.
  - If you spill fuel, do not attempt to start the engine. Avoid creating a source of ignition until the fuel vapors have dissipated.

- Store fuel in an approved container and keep it out of the reach of children.
- Fuel is harmful or fatal if swallowed. Long-term exposure to vapors can cause serious injury and illness.
  - Avoid prolonged breathing of vapors.
  - Keep your hands and face away from the nozzle and the fuel-tank opening.
  - Keep fuel away from your eyes and skin.

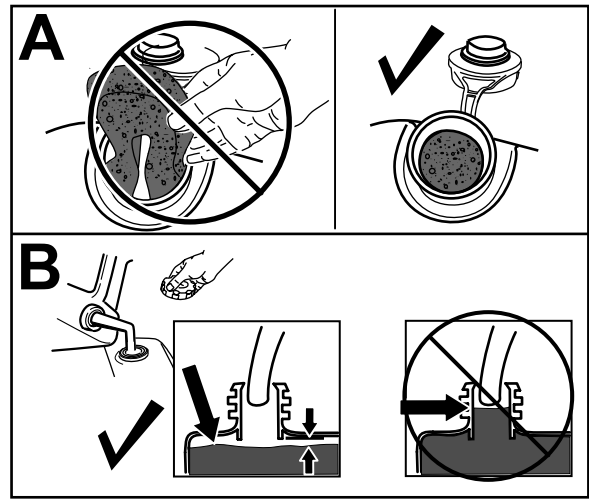

Figure 10

g234916

## Filling the Fuel Tank

- For best results, use only clean, fresh, unleaded gasoline with an octane rating of 87 or higher ((R+M)/2 rating method).
- Oxygenated fuel with up to 10% ethanol or 15% MTBE by volume is acceptable.
- **Do not** use ethanol blends of gasoline, such as E15 or E85, with more than 10% ethanol by volume. Performance problems and/or engine damage may result, which may not be covered under the warranty.
- **Do not** use gasoline containing methanol.
- **Do not** store fuel either in the fuel tank or in fuel containers over the winter unless fuel stabilizer has been added to the fuel.
- **Do not** add oil to gasoline.

Fill the fuel tank with fresh unleaded regular gasoline from a major name-brand service station.

**Important:** To reduce starting problems, add fuel stabilizer to the gasoline all season. Mix the stabilizer with gasoline less than 30 days old.

1. Clean around the fuel-tank cap and remove the cap from the tank (A of Figure 10).

**Important:** This machine is equipped with a premium fuel tank that uses a foam insert to prevent fuel agitation. Never remove the foam element, because it allows the engine to use all the fuel in the tank (B of Figure 10).

2. Install the fuel-tank cap and tighten it securely by hand.

# Checking the Engine-Oil Level

Service Interval: Before each use or daily

**Important:** If the oil level in the crankcase is too low or too high and you run the engine, you may damage the engine.

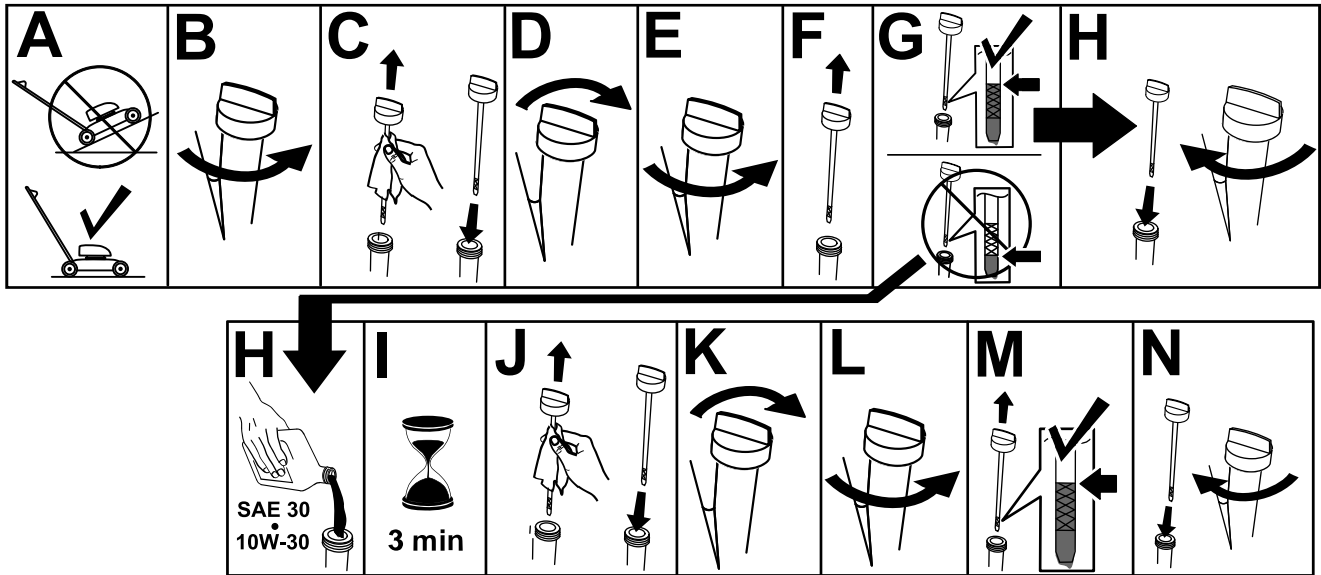

g222533

Figure 11

# Adjusting the Handle Height

You can raise or lower the handle to a position more comfortable for you.

1. Pull the handle-lock lever rearward to disengage the handle-lock pins ([Figure 12](#)).

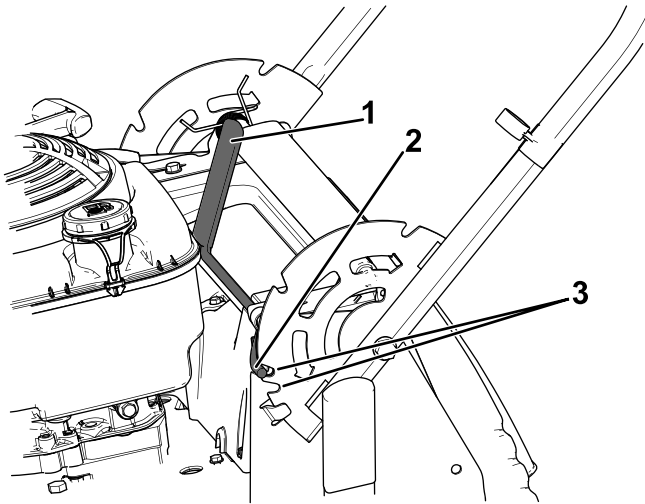

g191982

**Figure 12**

- |                        |            |
|------------------------|------------|
| 1. Handle-lock lever   | 3. Notches |
| 2. Handle-lock pin (2) |            |
- 
2. Rotate the handle and align the desired notch in the handle bracket to the handle-lock pins; refer to [Figure 12](#).
  3. Release the handle-lock lever to secure the handle in place.

# Adjusting the Cutting Height

## ⚠ CAUTION

If the engine has been running, the muffler will be hot and can severely burn you.

Keep away from the hot muffler.

**Note:** To raise the machine, move the front and rear cutting-height levers forward; to lower the machine, move the cutting-height levers rearward. Set all the wheels to the same height unless special circumstances require otherwise; refer to [Operating Tips](#) (page 21).

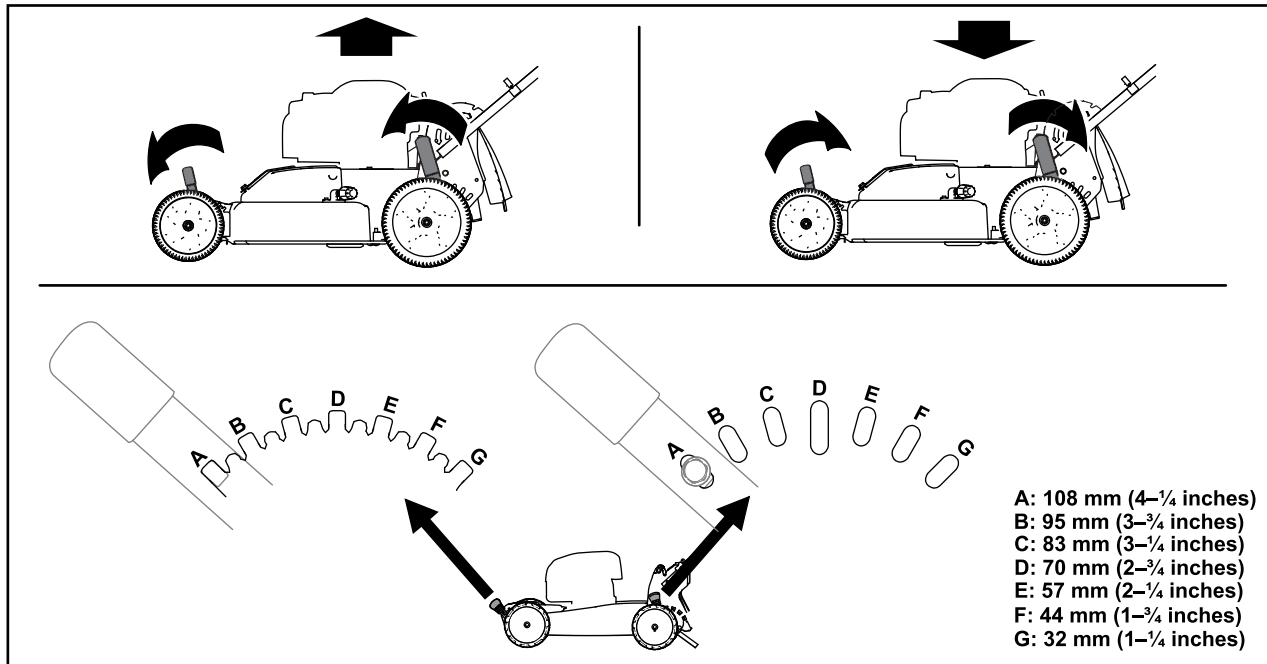

Figure 13

g224172

## During Operation

### During Operation Safety

#### General Safety

- Wear appropriate clothing, including eye protection; long pants; slip-resistant, substantial footwear; and hearing protection. Tie back long hair, secure loose clothing, and do not wear jewelry.
- Do not operate the machine while ill, tired, or under the influence of alcohol or drugs.
- The blade is sharp; contacting the blade can result in serious personal injury. Shut off the engine, remove the ignition key (electric-start model only), and wait for all moving parts to stop before leaving the operating position.
- When you release the blade-control bar, the engine should shut off and the blade should stop within 3 seconds. If not, stop using your machine immediately and contact an Authorized Service Dealer.
- Keep bystanders, especially small children, out of the operating area. Stop the machine if anyone enters the area.
- Always look down and behind you before moving the machine in reverse.
- Operate the machine only in good visibility and appropriate weather conditions. Do not operate the machine when there is the risk of lightning.
- Wet grass or leaves can cause serious injury if you slip and contact the blade. Avoid mowing in wet conditions.
- Use extreme care when approaching blind corners, shrubs, trees, or other objects that may block your view.
- Watch for holes, ruts, bumps, rocks, or other hidden objects. Uneven terrain could cause the

machine to overturn or cause you to lose your balance or footing.

- Stop the machine and inspect the blades after striking an object or if there is an abnormal vibration in the machine. Make all necessary repairs before resuming operation.
- Before leaving the operating position, shut off the engine, remove the ignition key (electric-start model only), and wait for all moving parts to stop.
- If the engine has been running the muffler will be hot and can severely burn you. Keep away from the hot muffler.
- Check the grass catcher components and the discharge chute frequently for any wear or deterioration and replace them with the

manufacturer's recommended parts when necessary.

- Use accessories and attachments approved by The Toro® Company only.

## Slope Safety

- Mow across the face of slopes; never up and down. Use extreme caution when changing direction on slopes.
- Do not mow on excessively steep slopes. Poor footing could cause a slip-and-fall accident.
- Mow with caution near drop-offs, ditches, or embankments.

## Starting the Engine

### Standard Model

Pull the recoil handle slowly until you feel resistance, then pull it sharply. Allow the rope to return to the engine slowly.

**Note:** If the machine does not start after several attempts, contact an Authorized Service Dealer.

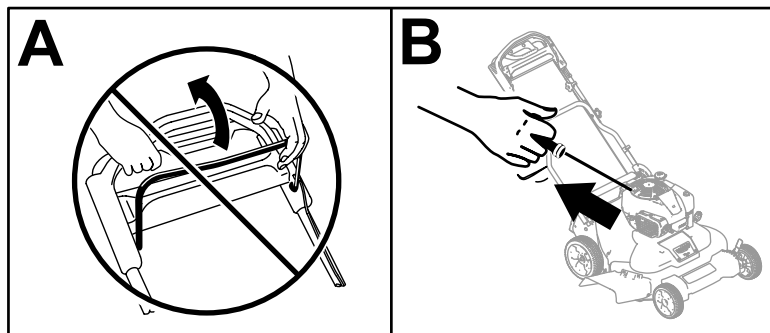

Figure 14

g234917

### Electric-start Model

You can start the engine on an electric-start model by using either the ignition key or the recoil-start handle.

- **Ignition Key:**
  1. Charge the battery for 24 hours before using the machine for the first time (A of [Figure 15](#)).

**Important:** Do not attempt to start the engine with the blade-control bar engaged; otherwise, you may blow the fuse (B of [Figure 15](#)).
  2. Insert the ignition key into the ignition (C of [Figure 15](#)).
  3. Turn and hold the ignition key to the Start position; when the engine starts, release the key (D of [Figure 15](#)).

**Note:** Do not hold the ignition key in the Start position for longer than 5 seconds to prevent burning out the starter motor.

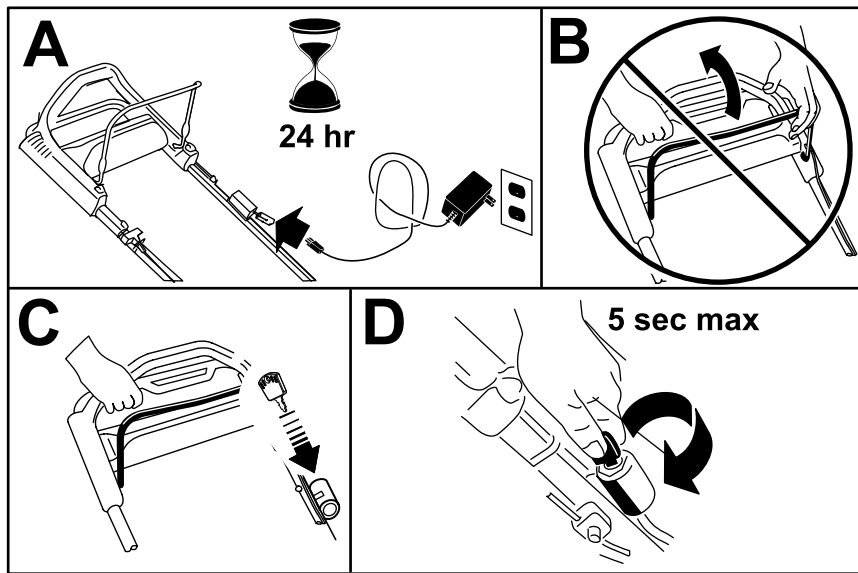

Figure 15

g234919



• **Recoil-Start Handle:**

1. Turn the ignition key to the RUN position (A of [Figure 16](#)).

**Important:** Do not attempt to start the engine with the blade-control bar engaged; otherwise, you may blow the fuse (B of [Figure 16](#)).

2. Pull the recoil handle slowly to the rear until you feel resistance, then pull sharply (C of [Figure 16](#)). Allow the rope to return to the engine slowly.

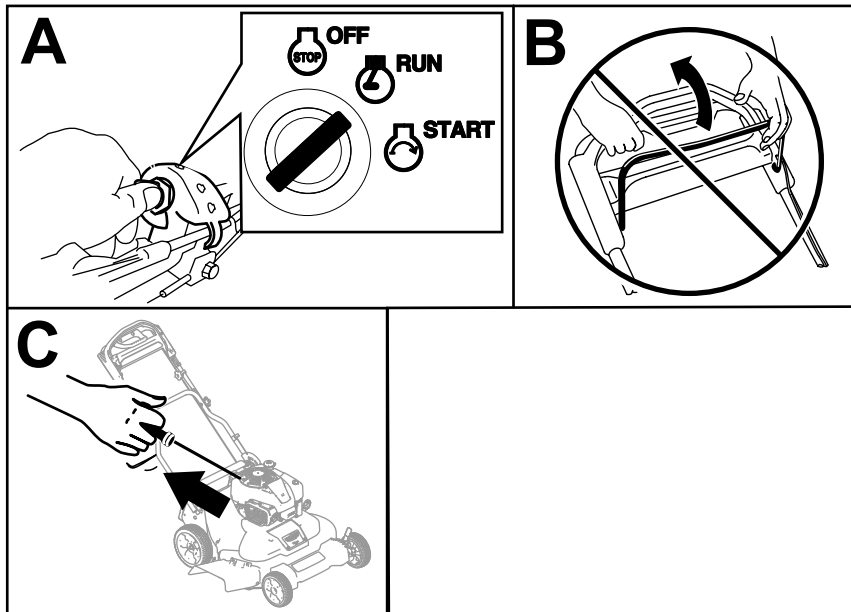

Figure 16

g234918

## Using the Self-Propel Drive

To operate the self-propel drive, simply walk with your hands gripping the upper handle and your elbows at your sides, and the machine will automatically keep pace with you ([Figure 17](#)).

**Note:** You can self-propel the machine with the blades engaged or disengaged.

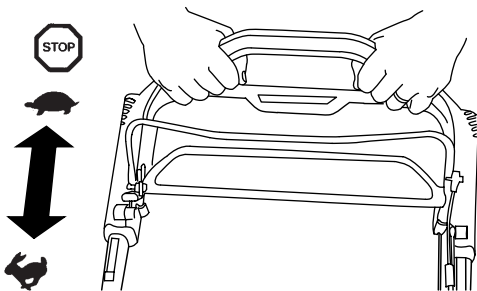

Figure 17

g193359

## Shutting Off the Engine

### Standard Model

Press the toggle switch ([Figure 17](#)) to the STOP position and hold it until the engine shuts off.

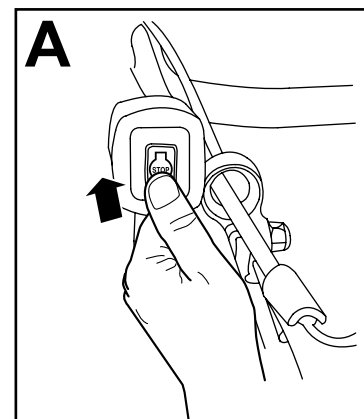

Figure 18

g234921

**Note:** Use the traction-assist handle in situations when you need more control than you have with the self-propel drive alone.

### Electric-Start Model

1. Turn the ignition key to the OFF position (A of [Figure 18](#)).

- When the engine shuts off, remove the ignition key and take it with you when you leave the machine (B of Figure 18).

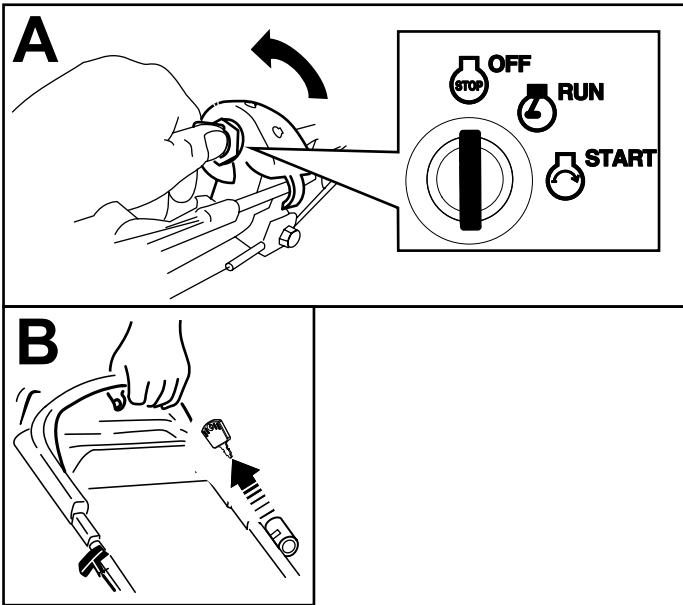

Figure 19

g234920

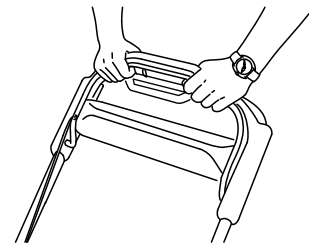

Figure 21

g193334

## Disengaging the Blades

Release the blade-control bar (Figure 22).

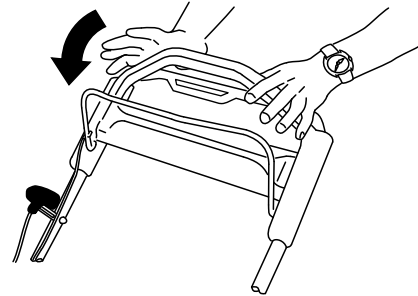

Figure 22

g193345

## Engaging the Blades

When you start your engine, the blades do not turn. You must engage the blades to mow.

- Pull the blade-control-bar lock back to the blade-control bar (Figure 20).

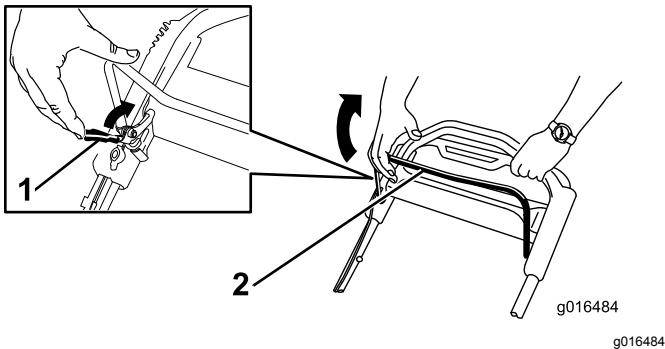

Figure 20

g016484

g016484

- Blade-control bar lock
- Blade-control bar

- Slowly** pull the blade-control bar back to the handle (Figure 20).
- Hold the blade-control bar against the handle (Figure 21).

**Important:** When you release the blade-control bar, the blades should stop within 3 seconds. If they do not stop properly, stop using your machine immediately and contact an Authorized Service Dealer.

# Checking the Blade-Stop System Operation

**Service Interval:** Before each use or daily

Check that the blades stop within 3 seconds of releasing the blade-control bar.

## Using the Grass Bag

You can use the grass bag to check the blade-stop system.

1. Remove the rear-discharge plug.
2. Install the empty grass bag on the machine.
3. Start the engine.
4. Engage the blades.

**Note:** The bag should begin to inflate, indicating that the blades are rotating.

5. While watching the bag, release the blade-control bar.

**Note:** If the bag does not deflate within 3 seconds of releasing the blade-control bar, the blade-stop system may be deteriorating and, if ignored, could result in an unsafe operating condition. Have the machine inspected and serviced by an Authorized Service Dealer.

6. Shut off the engine and wait for all moving parts to stop.

## Not Using the Grass Bag

1. Move the machine onto a paved surface in a non-windy area.
2. Set all 4 wheels to the 89 mm (3-1/2 inch) cutting height setting.
3. Take a half sheet of newspaper and crumple it into a ball small enough to go under the machine housing (about 76 mm (3 inches) in diameter).
4. Place the newspaper ball about 13 cm (5 inches) in front of the machine.
5. Start the engine.
6. Engage the blades.
7. Release the blade-control bar and begin counting out 3 seconds.
8. On the count of 3, push the machine quickly forward over the newspaper.
9. Shut off the engine and wait for all moving parts to stop.
10. Go to the front of the machine and check the newspaper ball.

**Note:** If the newspaper ball did not go under the machine, repeat steps 4 through 10.

11. If the newspaper is unravelled or shredded, the blades did not stop properly, which could result in an unsafe operating condition. Contact an Authorized Service Dealer.

## Recycling the Clippings

This machine comes from the factory ready to recycle grass and leaf clippings back into the lawn. To prepare the machine to recycle, do the following:

- If the side-discharge chute is on the machine, remove it and lower the side-discharge door; refer to [Removing the Side-Discharge Chute \(page 21\)](#).
- If the grass bag is on the machine, remove it; refer to [Removing the Grass Bag \(page 20\)](#).
- If the rear-discharge plug is not installed, grip it by the handle, raise the rear door, and insert it into the rear-discharge chute until the latch locks into place; refer to [Figure 22](#).

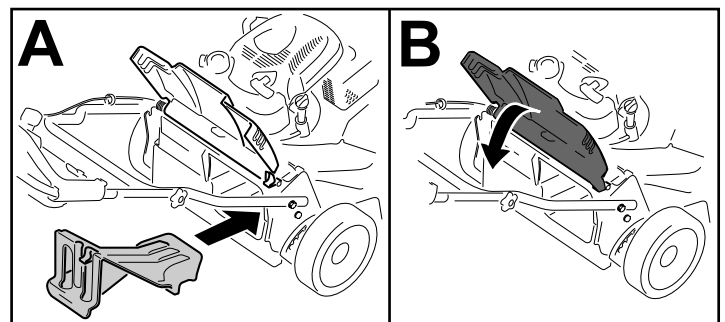

Figure 23

### **⚠ WARNING**

**Operating the machine to recycle lawn clippings without the plug in place allows objects to be thrown toward you or bystanders. Also, contact with the blades could occur. Thrown objects or blade contact can cause serious injury or death.**

**Ensure that the rear-discharge plug is in place before you recycle the clippings. Never engage the blades without either the rear-discharge plug or the grass bag installed on the machine.**

# Bagging the Clippings

Use the grass bag when you want to collect grass and leaf clippings from the lawn.

If the side-discharge chute is on the mower, remove it before bagging the clippings; refer to [Removing the Side-Discharge Chute \(page 21\)](#).

## Installing the Grass Bag

1. Raise and hold up the rear door (A of [Figure 24](#)).
2. Remove the rear-discharge plug by pulling down on the latch with your thumb and pulling the plug out from the machine (B of [Figure 24](#)).
3. Install the bag rod into the notches at the base of the handle and rock the bag back and forth to ensure that the rod is seated at the bottom of both notches (C of [Figure 24](#))
4. Lower the rear door until it rests on the grass bag.

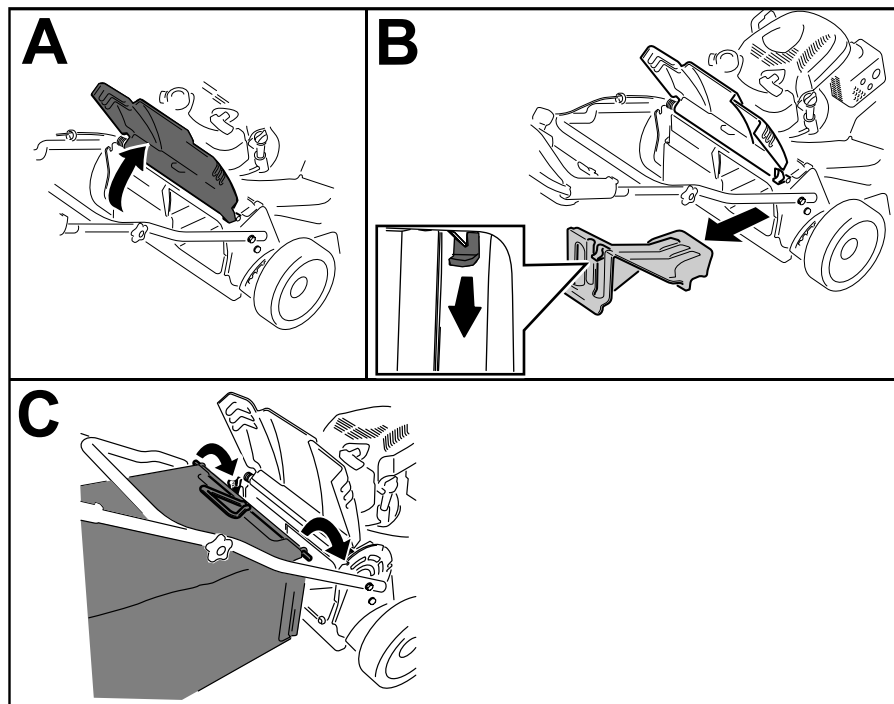

Figure 24

g234922

## Removing the Grass Bag

To remove the bag, reverse the steps in [Installing the Grass Bag \(page 20\)](#).

## Side-Discharging the Clippings

Use the side discharge for cutting very tall grass.

If the bag is on the machine, remove it and insert the rear-discharge plug; refer to [Removing the Grass Bag \(page 20\)](#) before side-discharging the clippings.

**Important:** Ensure that the rear-discharge plug is in place before you recycle the clippings ([Figure 23](#)).

## Installing the Side-Discharge Chute

1. Lift open the side-discharge door (A of [Figure 25](#)).
2. Install the side-discharge chute and close the door onto the chute (B and C of [Figure 25](#)).

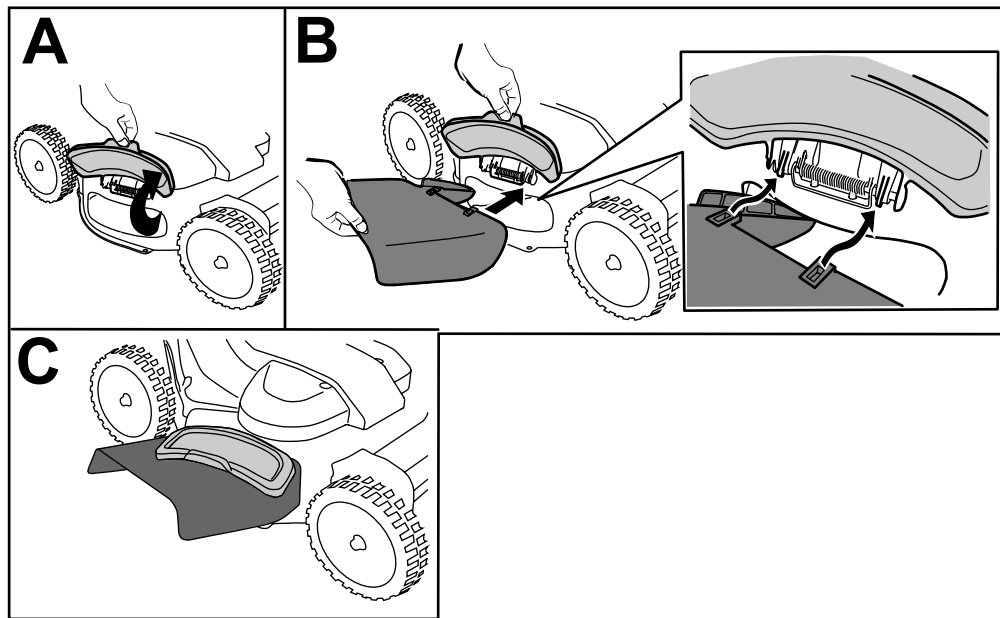

Figure 25

g234923

## Removing the Side-Discharge Chute

To remove the side-discharge chute, reverse the steps in [Installing the Side-Discharge Chute \(page 20\)](#).

## Operating Tips

### General Mowing Tips

- Inspect the area where you will use the machine and remove all objects that the machine could throw.
- Avoid striking solid objects with the blades. Never deliberately mow over any object.
- If the machine strikes an object or starts to vibrate, immediately shut off the engine, remove the key (if equipped), disconnect the wire from the spark plug, and examine the machine for damage.
- For best performance, install new blades before the cutting season begins.
- Replace the blades when necessary with Toro replacement blades.

### Cutting Grass

- Cut only about a third of the grass blade at a time. Do not cut below 51 mm (2 inches) unless the grass is sparse or it is late fall when grass growth begins to slow down.
- When cutting grass over 15 cm (6 inches) tall, mow at the highest cutting height setting and walk slower; then mow again at a lower setting for the best lawn appearance. If the grass is too long, the machine may plug and cause the engine to stall.

- Wet grass and leaves tend to clump on the yard and can cause the machine to plug or the engine to stall. Avoid mowing in wet conditions.
- Be aware of a potential fire hazard in very dry conditions, follow all local fire warnings, and keep the machine free of dry grass and leaf debris.
- Alternate the mowing direction. This helps disperse the clippings over the lawn for even fertilization.
- If the finished lawn appearance is unsatisfactory, try 1 or more of the following:
  - Replace the blades or have them sharpened.
  - Walk at a slower pace while mowing.
  - Raise the cutting height on your machine.
  - Cut the grass more frequently.
  - Overlap cutting swaths instead of cutting a full swath with each pass.

### Cutting Leaves

- After cutting the lawn, ensure that half of the lawn shows through the cut leaf cover. You may need to make more than a single pass over the leaves.
- If there are more than 13 cm (5 inches) of leaves on the lawn, mow at a higher cutting height and then again at the desired cutting height.
- Slow down your mowing speed if the machine does not cut the leaves finely enough.

# After Operation

## After Operation Safety

### General Safety

- Clean grass and debris from the machine to help prevent fires. Clean up oil or fuel spills.
- Allow the engine to cool before storing the machine in any enclosure.
- Never store the machine or fuel container where there is an open flame, spark, or pilot light, such as on a water heater or on other appliances.

### Hauling Safety

- Remove the ignition key (if equipped) before loading the machine for hauling.
- Use care when loading or unloading the machine.
- Secure the machine from rolling.

# Cleaning under the Machine

**Service Interval:** Before each use or daily

1. Move the machine to a level surface.
2. Shut off the engine and wait for all moving parts to stop before leaving the operating position.
3. Lower the machine to its lowest cutting-height setting. Refer to [Adjusting the Cutting Height \(page 14\)](#).
4. Attach a hose to the washout fitting, and turn the water on high ([Figure 26](#)).

**Note:** Spread petroleum jelly on the washout fitting O-ring to make the coupling slide on easier and protect the O-ring.

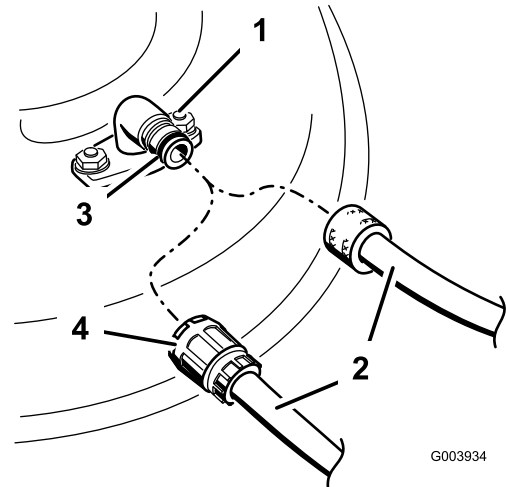

**Figure 26**

- |                    |             |
|--------------------|-------------|
| 1. Washout fitting | 3. O-ring   |
| 2. Hose            | 4. Coupling |

5. Start the engine, engage the blade-control lever, and let the machine run for 1 to 3 minutes with the blades turning.
6. Disengage the blade-control lever, shut off the engine, and wait for all moving parts to stop.
7. Shut off the water and remove the coupling from the washout fitting.

**Note:** If the machine is not clean after a single washing, soak it and let it stand for 30 minutes. Then repeat the process.

8. Run the machine again and engage the blades for 1 to 3 minutes to remove the excess water.

## **⚠ WARNING**

**A broken or missing washout fitting could expose you and others to thrown objects or blade contact. Contact with a blade or thrown debris can cause injury or death.**

- **Replace a broken or missing washout fitting immediately, before using the machine again.**
- **Never put your hands or feet under the machine or through openings in the machine.**

# Maintenance

## Recommended Maintenance Schedule(s)

| Maintenance Service Interval | Maintenance Procedure  |
|------------------------------|--|
| After the first 5 hours      | <ul style="list-style-type: none"><li>• Change the engine oil.</li></ul>   |
| Before each use or daily     | <ul style="list-style-type: none"><li>• Check the engine-oil level and add oil as needed.</li><li>• Check the blade-brake-clutch operation.</li><li>• Clean grass clippings and dirt from under the machine.</li><li>• Check the air filter and clean or replace it, if necessary.</li><li>• Check the cutting blades.</li></ul> |
| Every 25 hours               | <ul style="list-style-type: none"><li>• Charge the battery for 24 hours (electric-start model only).</li></ul>   |
| Every 50 hours               | <ul style="list-style-type: none"><li>• Clean the air filter; clean it more frequently in dusty operating conditions.</li><li>• Change the engine oil.</li><li>• Service the blade-drive system.</li></ul>   |
| Every 200 hours              | <ul style="list-style-type: none"><li>• Replace the air filter; replace it more frequently in dusty operation conditions.</li></ul>  |
| Yearly                       | <ul style="list-style-type: none"><li>• Service the air filter; service it more frequently in dusty operating conditions.</li><li>• Change the engine oil.</li><li>• Service the blades.</li></ul>   |
| Yearly or before storage     | <ul style="list-style-type: none"><li>• Charge the battery (electric-start model only).</li><li>• Empty the fuel tank before repairs as directed and before yearly storage.</li></ul>  |

**Important:** Refer to your engine owner's manual for additional maintenance procedures.

## Maintenance Safety

- Disconnect the spark-plug wire from the spark plug and remove the ignition key (electric-start model only) before performing any maintenance procedure.
- Wear gloves and eye protection when servicing the machine.
- The blade is sharp; contacting the blade can result in serious personal injury. Wear gloves when servicing the blade. Do not repair or alter the blade(s).
- Never tamper with safety devices. Check their proper operation regularly.
- Tipping the machine may cause the fuel to leak. Fuel is flammable and explosive, and can cause personal injury. Run the engine dry to remove the fuel with a hand pump; never siphon the fuel.
- To ensure optimum performance and continued safety certification of the machine, use only genuine Toro replacement parts and accessories. Replacement parts and accessories made by other manufacturers could be dangerous, and such use could void the product warranty.

## Preparing for Maintenance

1. Shut off the engine, remove the ignition key (if equipped), and wait for all moving parts to stop.
2. Disconnect the spark-plug wire from the spark plug (Figure 27).

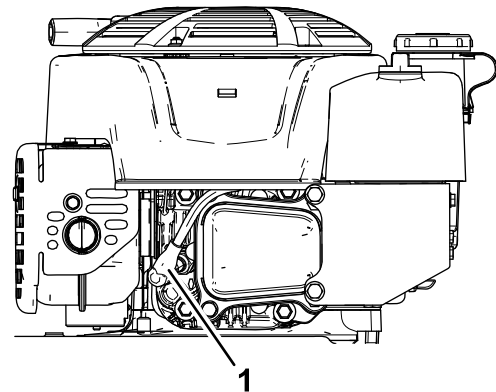

Figure 27

g191983

1. Spark-plug wire

3. After performing the maintenance procedure(s), connect the spark-plug wire to the spark plug.

**Important:** Before tipping the machine to change the oil or replace the blades, allow the fuel tank to run dry through normal



usage. If you must tip the machine prior to running out of fuel, use a hand fuel pump to remove the fuel. Always tip the machine onto its side, with the dipstick down.

## ⚠ WARNING

Tipping the machine may cause the fuel to leak. Fuel is flammable, explosive, and can cause personal injury.

Run the engine dry or remove the fuel with a hand pump; never siphon.

## Servicing the Air Filter

**Service Interval:** Before each use or daily—Check the air filter and clean or replace it, if necessary.

Every 50 hours—Clean the air filter; clean it more frequently in dusty operating conditions.

Yearly—Service the air filter; service it more frequently in dusty operating conditions.

Every 200 hours—Replace the air filter; replace it more frequently in dusty operation conditions.

1. Loosen the fastener and remove the air-filter cover (Figure 28).

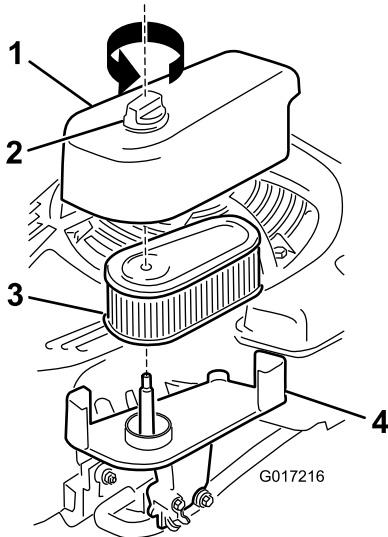

Figure 28

- |             |           |
|-------------|-----------|
| 1. Cover    | 3. Filter |
| 2. Fastener | 4. Base   |

2. Remove and inspect the filter.
  - If the filter is damaged or is wet with oil or fuel, replace it.
  - If the filter is dirty, tap it on a hard surface several times or blow the debris outward from the interior of the filter using compressed air at less than 207 kPa (30 psi).

**Note:** Do not brush or blow dirt from the outside of the filter; either forces dirt into the fibers.

3. Clean the air-filter body and cover using a damp rag. **Keep dirt away from the air opening.**
4. Install the filter onto the base.
5. Install the cover and screw the fastener down securely.

## Changing the Engine Oil

**Service Interval:** After the first 5 hours

Every 50 hours

Yearly

**Note:** Run the engine a few minutes before changing the oil to warm it. Warm oil flows better and carries more contaminants.

### Engine Oil Specifications

|                            |                                    |
|----------------------------|------------------------------------|
| Engine oil capacity        | 0.53 L (18 fl oz)                  |
| Oil viscosity              | SAE 30 or SAE 10W-30 detergent oil |
| API service classification | SJ or higher                       |

1. Move the machine to a level surface.
2. Refer to [Maintenance \(page 24\)](#).
3. Remove the dipstick by rotating the cap counterclockwise and pulling it out (Figure 29).

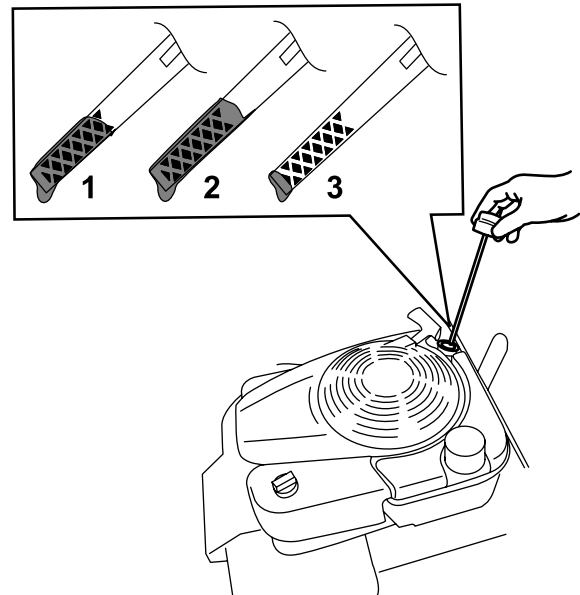

Figure 29

- |         |        |
|---------|--------|
| 1. Full | 3. Low |
| 2. High |        |

- Tip the machine onto its side (so that the air filter is up) to drain the used oil from the oil-fill tube (Figure 30).

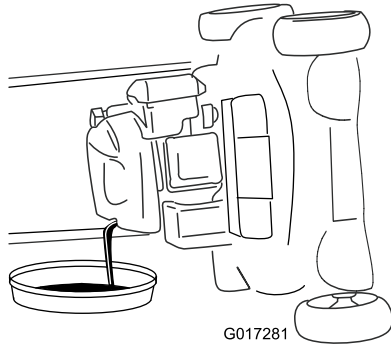

Figure 30

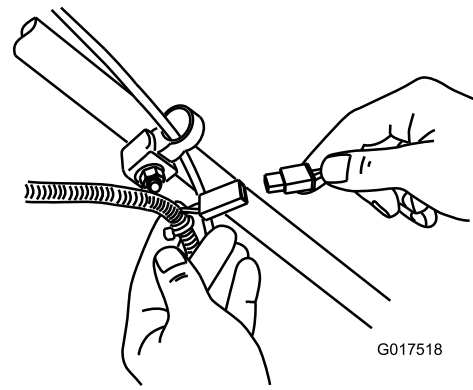

Figure 31

- After draining the used oil, return the machine to the operating position.
- Carefully pour about 3/4 of the engine capacity of oil into the oil-fill tube.
- Wait 3 minutes for the oil to settle in the engine.
- Wipe the dipstick clean with a clean cloth.
- Insert the dipstick into the oil-fill tube, then remove the dipstick.
- Read the oil level on the dipstick (Figure 29).
  - If the oil level on the dipstick is too low, carefully pour a small amount of oil into the oil-fill tube, wait 3 minutes, and repeat steps 8 through 10 until the oil level on the dipstick is correct.
  - If the oil level on the dipstick is too high, drain the excess oil until the oil level on the dipstick is correct.
- Install the dipstick into the oil-fill tube securely.
- Recycle the used oil properly.

- Plug the charger into a wall outlet.

**Note:** When the battery no longer holds a charge, recycle or dispose of the lead-acid battery according to local codes.

**Note:** Your battery charger may have a 2-color LED display that indicates the following states of charging:

- A red light indicates that the charger is charging the battery.
- A green light indicates that the charger is fully charged or is disconnected from the battery.
- A flashing light that alternates between red and green indicates that the battery is nearly fully charged. This state lasts only a few minutes until the battery is fully charged.

## Charging the Battery

### Electric-Start Model Only

**Service Interval:** Every 25 hours  
Yearly or before storage

Charge the battery for 24 hours initially, then monthly (every 25 starts) or as needed. Always use the charger in a sheltered area, and charge the battery at room temperature (about 22°C or 70°F) whenever possible.

**Note:** The machine is not equipped with an alternator charging system.

- Connect the charger to the wire harness located below the ignition key (Figure 31).

# Replacing the Fuse

## Electric-Start Model Only

If the battery does not charge or the engine does not run with the electric starter, the fuse may be blown. Replace it with a 40 A plug-in type fuse.

**Important:** You cannot start the machine with the electric starter or charge the battery unless a working fuse is installed.

1. Open the sealed fuse holder and replace the fuse (Figure 32).

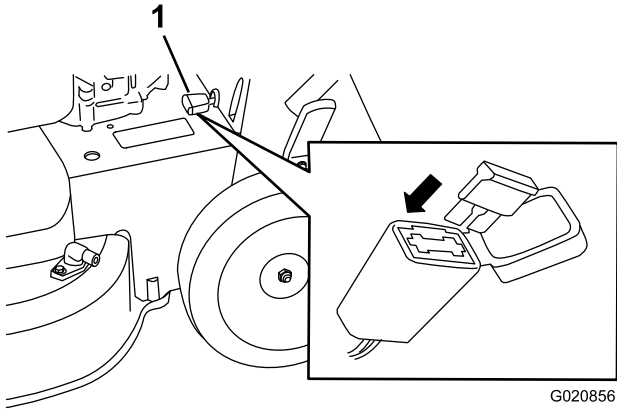

Figure 32

1. Fuse holder

2. Close the cover to the fuse holder, and ensure that it is sealed tightly.

# Replacing the Battery

Electric-start model only

## Removing the Old Battery

1. Contact an Authorized Toro Parts Dealer to obtain a replacement battery.
2. Remove the belt cover; refer to step 1 of [Servicing the Blade-Drive System \(page 28\)](#).
3. Remove the rear-discharge plug.
4. Move the handle to the vertical position.
5. Remove the 4 small bolts that hold the rear door and handle-lock-lever assembly in place.
6. Fold the handle all the way forward.
7. Remove the rear door and handle-lock lever assembly (Figure 33).

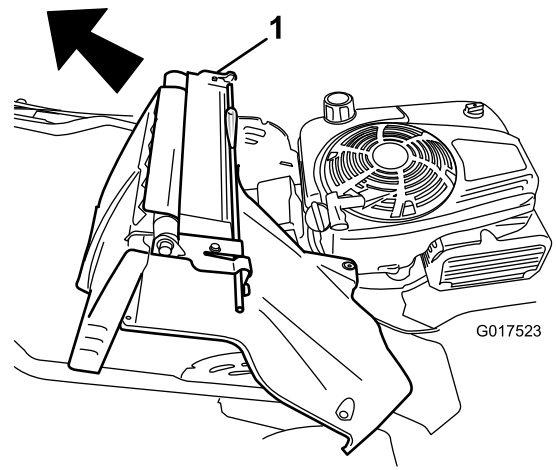

Figure 33

1. Rear door and handle-lock-lever assembly

8. Remove the cover from the battery.
9. Disconnect the leads from the battery.
10. Remove the battery and recycle it.

**Note:** Recycle the battery according to your state and local regulations.

## Installing the New Battery

1. Clean the battery-holding area on the machine housing.
2. Set the new battery in place on the machine housing.
3. Connect the leads to the new battery.  
**Note:** Ensure that you connect the black (negative) wire to the negative (-) terminal and the red (positive) wire to the positive (+) terminal.
4. Install the cover onto the battery.  
**Note:** Ensure that the cover fits properly over the wire harness.
5. Install the rear door and handle-lock-lever assembly onto the machine.
6. Raise the handle to the vertical position.
7. Secure the shroud with the 4 small bolts that you removed in step 5 of [Removing the Old Battery \(page 27\)](#).
8. Install the rear-discharge plug.
9. Return the handle to the operating position.

# Adjusting the Self-Propel Drive

Whenever you install a new self-propel cable or if the self-propel drive is out of adjustment, adjust the self-propel drive.

1. Turn the adjustment knob counterclockwise to loosen the cable adjustment (Figure 34).

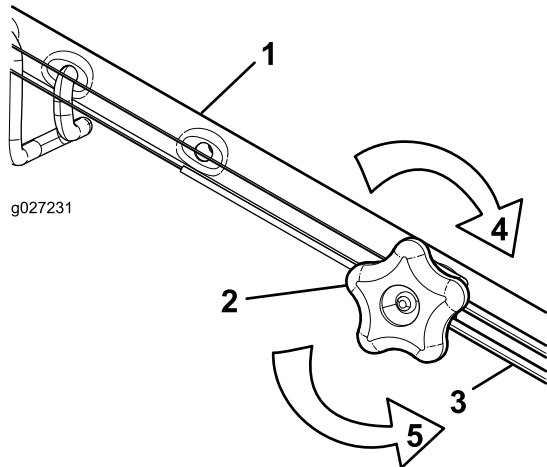

Figure 34

- |                            |   |
|----------------------------|---|
| 1. Handle (left side)      | 4. Turn the knob clockwise to tighten the adjustment.       |
| 2. Adjustment knob         | 5. Turn the knob counterclockwise to loosen the adjustment. |
| 3. Self-propel-drive cable |   |

2. Adjust the tension on the cable (Figure 34) by pulling it back or pushing it forward and holding that position.

**Note:** Push the cable toward the engine to increase the traction; pull the cable away from the engine to decrease the traction.

3. Turn the adjustment knob clockwise to tighten the cable adjustment.

**Note:** Tighten the knob firmly by hand.

# Servicing the Blade-Drive System

**Service Interval:** Every 50 hours

1. Remove the blade-drive system cover (Figure 35).

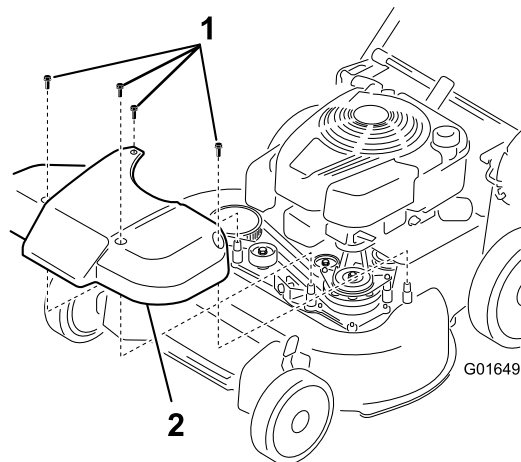

Figure 35

- |          |          |
|----------|----------|
| 1. Bolts | 2. Cover |
|----------|----------|

2. Brush or blow out debris from the inside of the shield and around all the parts.
3. Hold a 0.25 mm (0.010 inch) feeler gauge, a piece of paper, or a note card against the wall and slide it down behind the belt tension spring.

**Note:** If there is a visible gap between the gauge and the spring, tighten the adjusting bolt and the nut until the paper barely slides freely in and out of the gap (Figure 36).

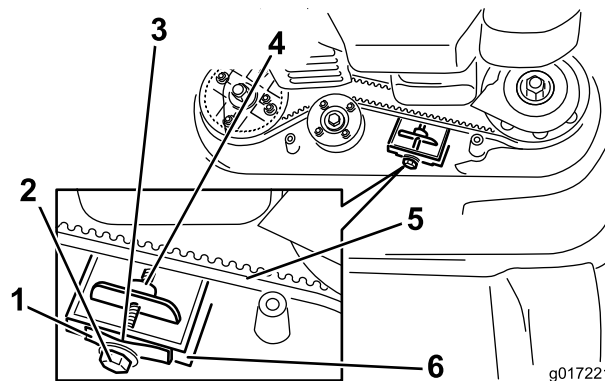

Figure 36

- |                        |                     |
|------------------------|---------------------|
| 1. Belt-tension spring | 4. Adjusting nut    |
| 2. Adjusting bolt      | 5. Blade-drive belt |
| 3. Gap                 | 6. Wall             |

**Important:** Do not overtighten the adjusting bolt. This could damage the blade-drive belt.

4. Install the blade-drive system cover that you previously removed.

## Servicing the Blades

**Service Interval:** Yearly

**Important:** You will need a torque wrench to install the blades properly. If you do not have a torque wrench or are uncomfortable performing this procedure, contact an Authorized Service Dealer.

Examine the blades whenever you run out of fuel. If the blades are damaged or cracked, replace them immediately. If the blade edges are dull or nicked, have them sharpened and balanced, or replace them.

**Important:** Always wear padded gloves when working with the blade.

### **⚠ DANGER**

A worn or damaged blade can break, and a piece of the blade could be thrown toward you or bystanders, resulting in serious personal injury or death.

- Inspect the blades periodically for wear or damage.
- Replace a worn or damaged blade.

**Note:** Maintain sharp blades throughout the cutting season, because sharp blades cut cleanly without tearing or shredding the grass blades.

## Preparing to Service the Cutting Blades

1. Lock the handle in the vertical position (Figure 37); refer to [Adjusting the Handle Height](#) (page 13).

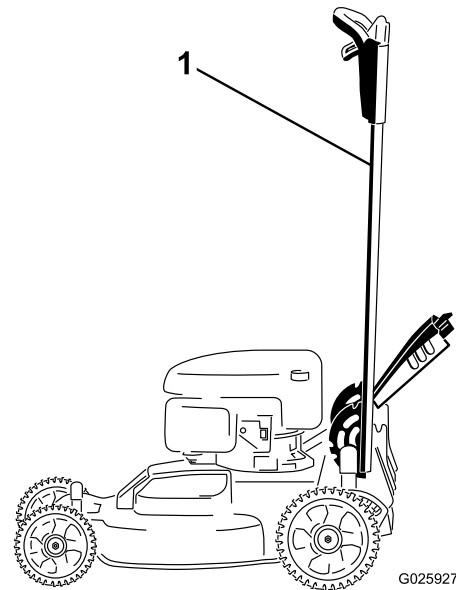

**Figure 37**

1. Handle locked in the vertical position
- 
2. Tip the machine onto its side, with the dipstick down, until the upper handle rests on the ground.

## Inspecting the Blades

**Service Interval:** Before each use or daily

1. Inspect the cutting edges (Figure 38). If the edges are not sharp or have nicks, remove the blades and have them sharpened or replace them.

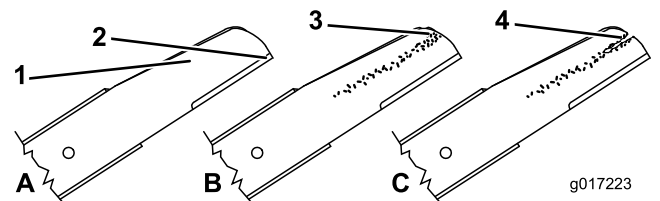

**Figure 38**

1. Cutting edge
2. Curved area
3. Wear/slot forming
4. Crack

2. Inspect the blades themselves, especially the curved area (Figure 38). If you notice any damage, wear, or a slot forming in this area, immediately replace it with a new blade.

## ⚠ DANGER

If you allow a blade to wear, a slot will form between the sail and flat part of the blade. Eventually a piece of the blade may break off and be thrown from under the housing, possibly resulting in serious injury to you or bystanders.

- Inspect the blade periodically for wear or damage.
  - Never try to straighten a blade that is bent or weld a broken or cracked blade.
  - Replace a worn or damaged blade.
3. Check for bent blades; refer to [Checking for Bent Blades](#) (page 30).

## Checking for Bent Blades

1. Rotate the blades to the position shown in [Figure 39](#).

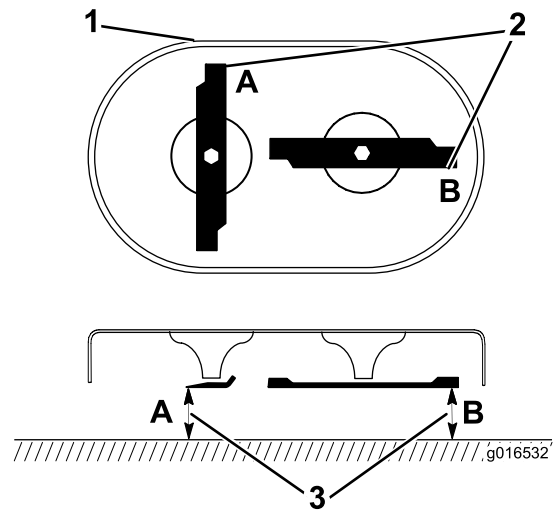

Figure 39

g016532

1. Front of cutting deck
2. Measure at locations A and B
3. Measure from the cutting edge to a smooth, level surface

2. Measure from a level surface to the cutting edges at locations **A** and **B** ([Figure 39](#)), and record both dimensions.
3. Rotate the blades so that their opposite ends are at locations **A** and **B** ([Figure 39](#)).
4. Repeat the measurements in step 2 and record them.

**Note:** If the difference between the dimensions **A** and **B** obtained in steps 2 and 4 exceeds 3 mm (1/8 inch), the blade is bent and you will need to replace it. Refer to [Removing the Blades](#) (page 31) and [Installing the Blades](#) (page 31).

## ⚠ WARNING

A blade that is bent or damaged could break apart and could seriously injure or kill you or bystanders.

- Always replace a bent or damaged blade with a new blade.
- Never file or create sharp notches in the edges or surfaces of a blade.

# Removing the Blades

Replace the blades when the machine hits a solid object or when a blade is out of balance or bent. Use only genuine Toro replacement blades.

1. Use a block of wood to hold each blade steady and turn the blade bolt counterclockwise as shown in [Figure 40](#).

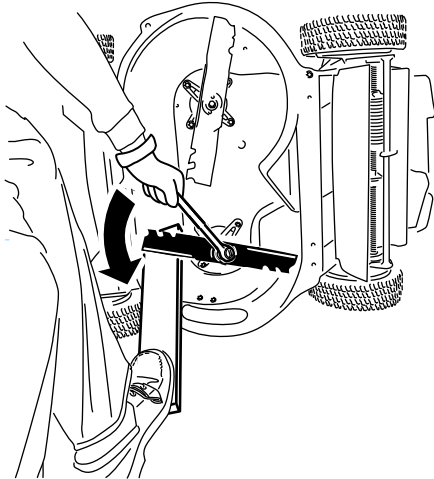

Figure 40

g232790

2. Remove each blade as shown in [Figure 41](#).

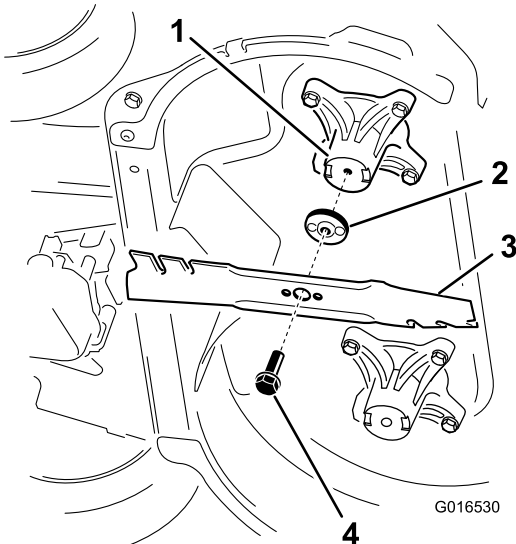

Figure 41

G016530

g016530

- |                     |                   |
|---------------------|-------------------|
| 1. Spindle (2)      | 3. Blade (2)      |
| 2. Blade driver (2) | 4. Blade bolt (2) |
3. Inspect the pins on the blade drivers for wear and damage.

# Installing the Blades

1. Install the first blade so that it is horizontal, along with all mounting hardware as shown in [Figure 41](#).

**Note:** Tighten the bolt with your fingers.

**Important:** Position the curved ends of the blades to point toward the machine housing. Be sure to nest the raised areas on each blade driver with the recesses in the head of its corresponding spindle, and the pins on the other side of each blade driver with the holes in its corresponding blade.

2. Steady each blade with a board and turn the blade bolt clockwise with a torque wrench as shown in [Figure 42](#); torque the blade bolt to 82 N·m (60 ft·lb).

**Important:** A bolt torqued to 82 N·m (60 ft·lb) is very tight. Put your weight behind the wrench and tighten the bolt securely. This bolt is very difficult to overtighten.

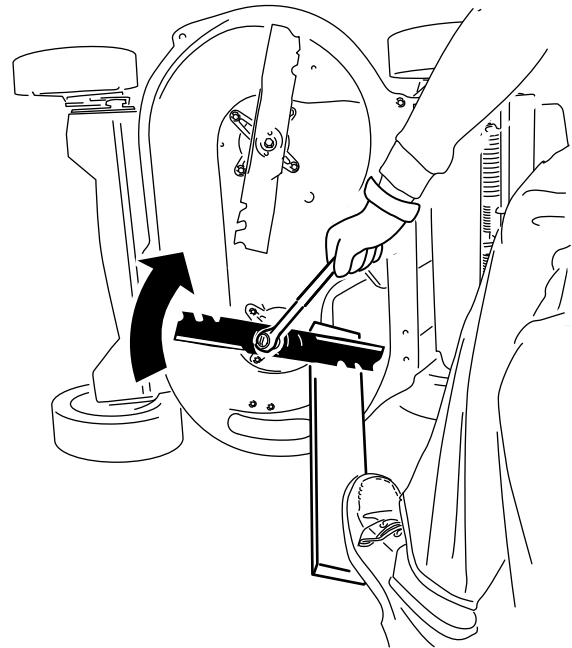

Figure 42

g232801

3. Rotate the installed blade 1/4 turn until it is vertical, and install the other blade in the same manner as the first (refer to step 1).

**Note:** The blades should be perpendicular, forming an inverted "T" as shown in [Figure 43](#).

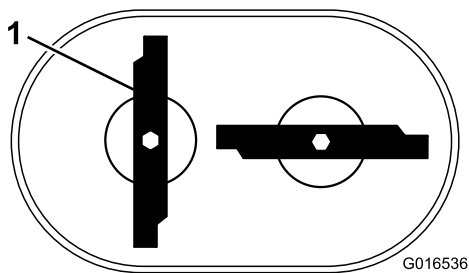

Figure 43

g016536

1. Blade (2)

4. Tighten the second blade; refer to step 2.
5. Rotate the blades by hand a full 360° turn to ensure that they do not touch.

**Note:** If the blades touch each other, they are not mounted correctly. Repeat steps 1 through 3, until the blades no longer touch each other.

### **⚠ WARNING**

**Incorrectly installing the blades could damage the machine or cause an injury to you or bystanders.**

**Use care when installing the blades.**

## Storage

Store the machine in a cool, clean, dry place.

## General Information

1. Perform the recommended annual maintenance procedures; refer to [Maintenance \(page 24\)](#).
2. Clean under the machine housing; refer to [Cleaning under the Machine \(page 22\)](#).
3. Remove chaff, dirt, and grime from the external parts of the engine, the shrouding, and the top of the machine.
4. Check the condition of the blades; refer to [Inspecting the Blades \(page 29\)](#).
5. Service the air filter; refer to [Servicing the Air Filter \(page 25\)](#).
6. Tighten all nuts, bolts, and screws.
7. Touch up all rusted or chipped paint surfaces with paint available from an Authorized Service Dealer.
8. **Electric-start model only:** Charge the battery for 24 hours, then unplug the battery charger and store the machine in an unheated area. If you must store the machine in a heated area, you must charge the battery every 90 days.
9. Fold the handle for storage.

## Preparing the Fuel System

### **⚠ WARNING**

**Fuel can vaporize if you store it over long periods of time and explode if it comes into contact with an open flame.**

- **Do not store fuel over long periods of time.**
- **Do not store the machine with fuel in the fuel tank or the carburetor in an enclosure with an open flame. (For example, a furnace or a water heater pilot light.)**
- **Allow the engine to cool before storing it in any enclosure.**

On the last refueling of the year, add fuel stabilizer to the fuel as directed by the engine manufacturer. Empty the fuel tank when mowing the last time before storing the machine.

1. Run the machine until the engine shuts off from running out of fuel.
2. Start the engine again and allow it to run until it shuts off. When you can no longer start the engine, it is sufficiently dry.



## Preparing the Engine

1. While the engine is still warm, change the engine oil; refer to [Changing the Engine Oil \(page 25\)](#).
2. Disconnect the wire from the spark plug and remove the ignition key (electric-start model only).
3. Remove the spark plug.
4. Using an oil can, add about 30 ml (1 fl oz), of motor oil to the engine through the spark-plug hole.
5. Slowly pull the starter rope several times to distribute oil throughout the cylinder.
6. Install the spark plug but do not connect the wire to the spark plug. Secure the wire so that it does not come into contact with the spark plug.

## Removing the Machine from Storage

1. Unfold the handle; refer to [1 Assembling and Unfolding the Handle \(page 6\)](#).
2. Check and tighten all fasteners.
3. Remove the spark plug and spin the engine rapidly using the starter to blow excess oil from the cylinder.
4. Inspect the spark plug and replace it if it is dirty, worn, or cracked; refer to the engine owner's manual.
5. Install the spark plug and tighten it to the recommended torque of 20 N·m (15 ft·lb).
6. Perform any needed maintenance procedures; refer to [Maintenance \(page 24\)](#).
7. Check the engine-oil level; refer to [Checking the Engine-Oil Level \(page 12\)](#).
8. Fill the fuel tank with fresh fuel; refer to [Filling the Fuel Tank \(page 11\)](#).
9. **Electric-start model only:** Charge the battery; refer to [5 Charging the Battery \(page 9\)](#).
10. Connect the wire to the spark plug.

**Notes:**

# California Proposition 65 Warning Information

## What is this warning?

You may see a product for sale that has a warning label like the following:



**WARNING: Cancer and Reproductive Harm—[www.p65Warnings.ca.gov](http://www.p65Warnings.ca.gov).**

## What is Prop 65?

Prop 65 applies to any company operating in California, selling products in California, or manufacturing products that may be sold in or brought into California. It mandates that the Governor of California maintain and publish a list of chemicals known to cause cancer, birth defects, and/or other reproductive harm. The list, which is updated annually, includes hundreds of chemicals found in many everyday items. The purpose of Prop 65 is to inform the public about exposure to these chemicals.

Prop 65 does not ban the sale of products containing these chemicals but instead requires warnings on any product, product packaging, or literature with the product. Moreover, a Prop 65 warning does not mean that a product is in violation of any product safety standards or requirements. In fact, the California government has clarified that a Prop 65 warning "is not the same as a regulatory decision that a product is 'safe' or 'unsafe.'" Many of these chemicals have been used in everyday products for years without documented harm. For more information, go to <https://oag.ca.gov/prop65/faqs-view-all>.

A Prop 65 warning means that a company has either (1) evaluated the exposure and has concluded that it exceeds the "no significant risk level"; or (2) has chosen to provide a warning based on its understanding about the presence of a listed chemical without attempting to evaluate the exposure.

## Does this law apply everywhere?

Prop 65 warnings are required under California law only. These warnings are seen throughout California in a wide range of settings, including but not limited to restaurants, grocery stores, hotels, schools, and hospitals, and on a wide variety of products. Additionally, some online and mail order retailers provide Prop 65 warnings on their websites or in catalogs.

## How do the California warnings compare to federal limits?

Prop 65 standards are often more stringent than federal and international standards. There are various substances that require a Prop 65 warning at levels that are far lower than federal action limits. For example, the Prop 65 standard for warnings for lead is 0.5 µg/day, which is well below the federal and international standards.

## Why don't all similar products carry the warning?

- Products sold in California require Prop 65 labelling while similar products sold elsewhere do not.
- A company involved in a Prop 65 lawsuit reaching a settlement may be required to use Prop 65 warnings for its products, but other companies making similar products may have no such requirement.
- The enforcement of Prop 65 is inconsistent.
- Companies may elect not to provide warnings because they conclude that they are not required to do so under Prop 65; a lack of warnings for a product does not mean that the product is free of listed chemicals at similar levels.

## Why does Toro include this warning?

Toro has chosen to provide consumers with as much information as possible so that they can make informed decisions about the products they buy and use. Toro provides warnings in certain cases based on its knowledge of the presence of one or more listed chemicals without evaluating the level of exposure, as not all the listed chemicals provide exposure limit requirements. While the exposure from Toro products may be negligible or well within the "no significant risk" range, out of an abundance of caution, Toro has elected to provide the Prop 65 warnings. Moreover, if Toro does not provide these warnings, it could be sued by the State of California or by private parties seeking to enforce Prop 65 and subject to substantial penalties.



**Count on it.**