



Count on it.

Parts Catalog

66in Rake-O-Vac® Sweeper

Model No. 07050—Serial No. 311000001 and Up



Ordering Replacement Parts

To order replacement parts, please supply the part number, the quantity, and the description of each part desired.

Understanding Reference Numbers

Each identified part in an illustration has a reference number. The reference number for a part also appears in the parts list, along with other information about the part.

This catalog uses two special reference number formats, one to indicate parts in a service assembly and another to indicate the quantity of a given part in an illustration.

Service Assembly Reference Numbers

Parts in service assemblies have reference numbers in the form a:b. The a represents the reference number of the entire service assembly and the b represents a sequential number unique to each part within the service assembly.

For example, a wheel assembly might be identified by reference number 6, the tire by 6:1, the valve by 6:2, and the wheel by 6:3. When you order the assembly identified by reference number 6, you receive all parts identified by reference numbers 6:1, 6:2, and 6:3. However, you may also order any part individually. Reference numbers of this type appear in illustration and in parts lists.

Reference Numbers Indicating Quantity

In an illustration, if a reference number indicates more than one part, the reference number has the form nX y. The n represents the quantity of the part, the X is the multiplication symbol, and the y represents the reference number.

For example, in an illustration, the reference number 2X 37 means that two of the parts identified by reference number 37 are indicated.

Contents

Frame and Wheel Assembly	4
Axle and Hub Assembly	5
Blower and Throat Mounting Assembly	6
Blower and Throat Assembly	7
Blower Decal and Cover Assembly	8
Hopper Mounting Assembly	9
Hopper Assembly	10
Rake and LH Trailing Arm Assembly	11
LH Trailing Arm Assembly No. 117-8470	12
Rake Assembly	13
RH Trailing Arm Mounting Assembly	14
RH Trailing Arm Assembly No. 117-8460	15
Engine, Clutch and Muffler Assembly	16
Centrifugal Clutch Assembly No. 107-1050	18
Clutch Assembly No. 107-1070	19
Idler, Pully and Belt Assembly	20
Fuel Tank and Battery Assembly	21
Fuel Tank Assembly No. 117-8454	22
Attachments and Accessories	23

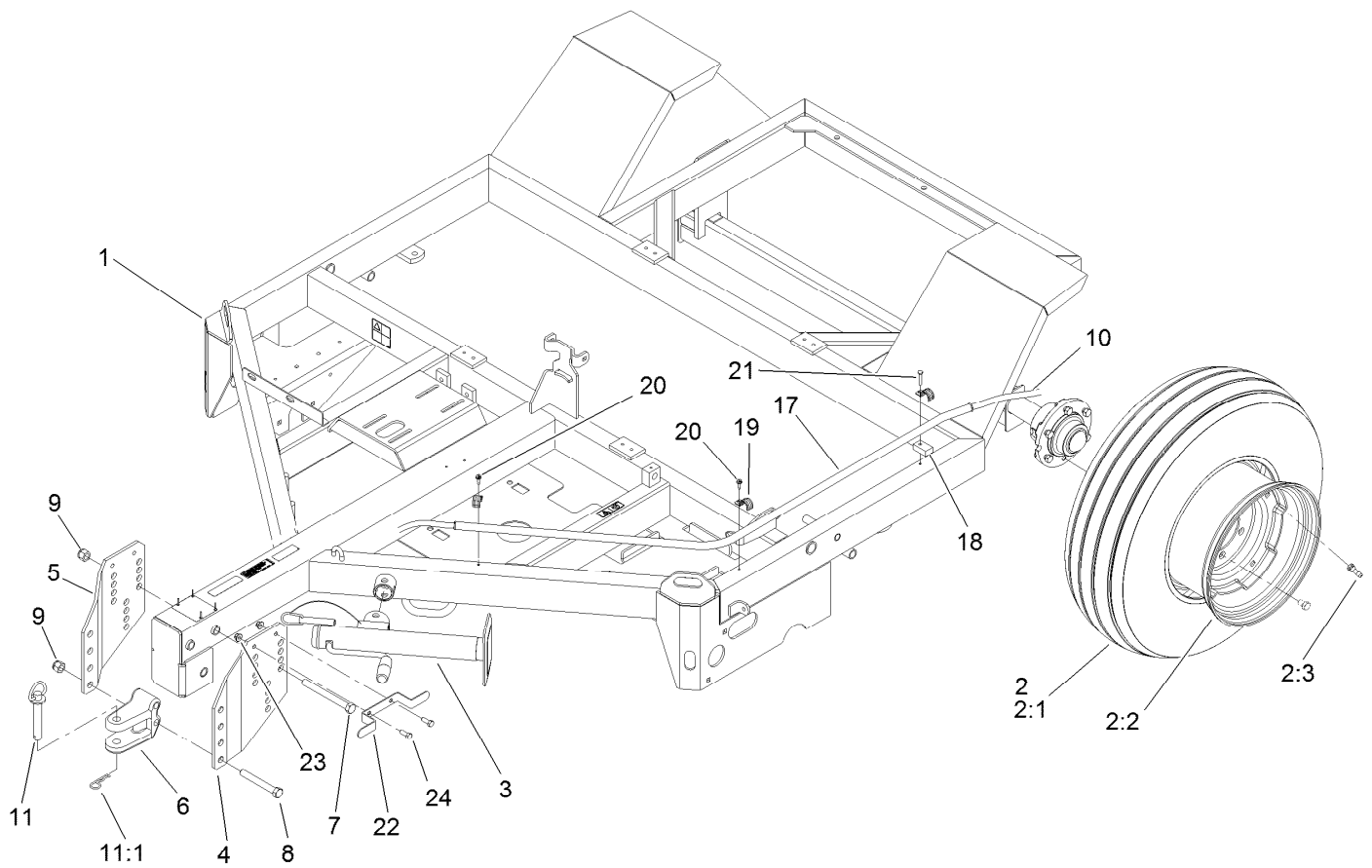

Frame and Wheel Assembly

<i>Ref.</i>	<i>Part Number</i>	<i>Qty.</i>	<i>Description</i>	<i>Ref.</i>	<i>Part Number</i>	<i>Qty.</i>	<i>Description</i>
1	119-6272	1	Frame	10	20-9580	1	Latch-Rope
2	119-6224	2	Wheel And Tire ASM	11	13-6200	1	Pin-Hitch, Pointed
2:1	119-6225	1	Tire	11:1	3290-343	1	Pin-Hair
2:2	119-6226	1	Wheel	17	13-6890-01	1	Guide-Rope
2:3	232-27	1	Stem-Valve	18	13-6910-01	1	Spacer-Guide, Rope
3	106-9699	1	Jack	19	2412-40	3	Clamp-Conduit
4	110-7518-03	1	Plate-Hitch, LH	20	32104-95	2	Screw-HWH
5	110-7519-03	1	Plate-Hitch, RH	21	32104-96	1	Screw-HH
6	47-3550-03	1	Hitch-Clevis	22	106-0262-01	1	Mount-Harness
7	327-17	3	Screw-HH	23	104-8301	2	Nut-HF, NI
8	327-12	2	Screw-HH	24	323-6	2	Screw-HH
9	3296-53	5	Nut-Lock, NI				

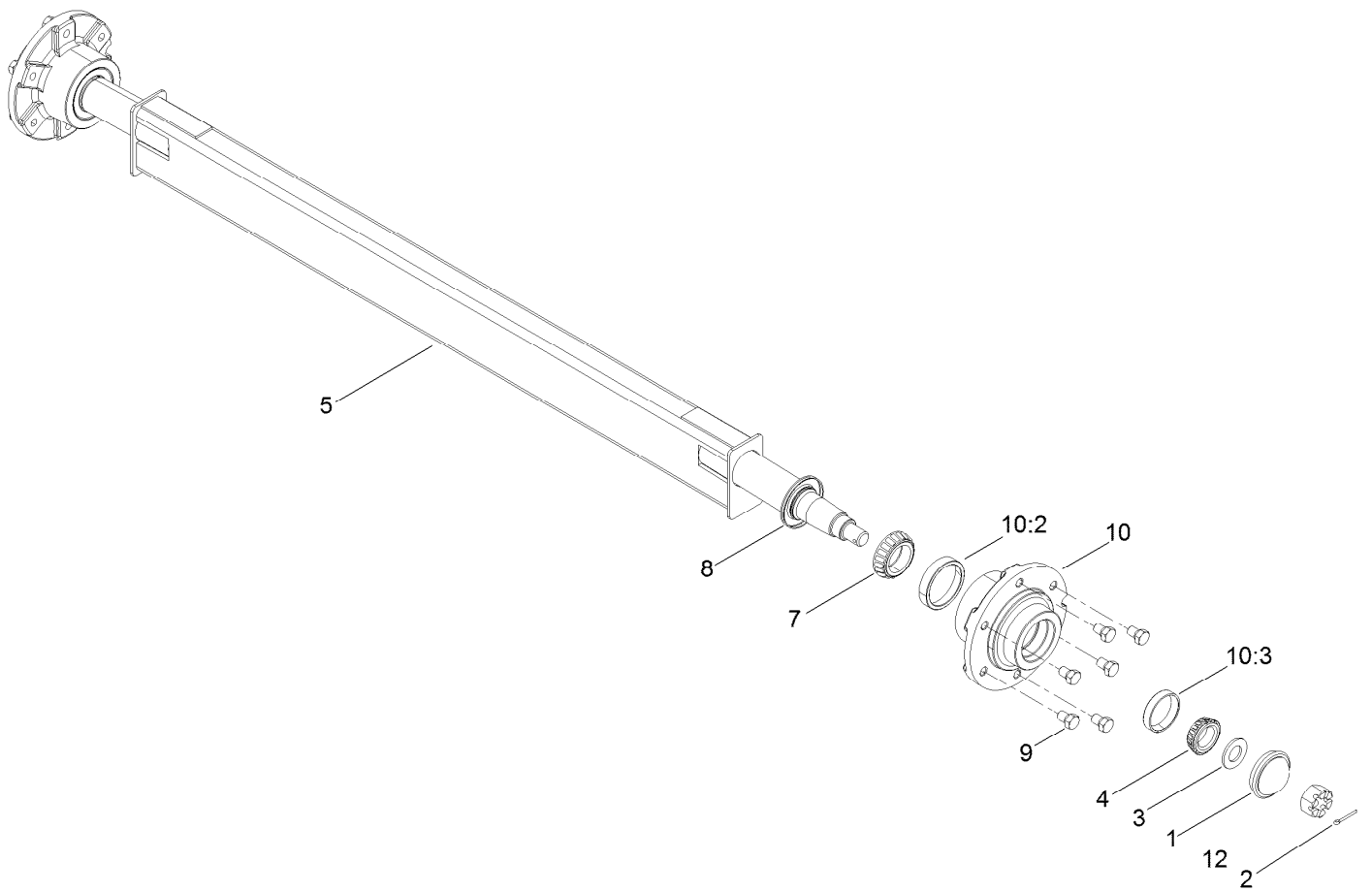

Axle and Hub Assembly

<i>Ref.</i>	<i>Part Number</i>	<i>Qty.</i>	<i>Description</i>
1	217-111	2	Cap-Hub
2	3272-17	2	Pin-Cotter
3	3256-29	2	Washer-Flat
4	254-62	2	Bearing-Roller, Cone
5	117-8450	1	Axle
7	254-65	2	Bearing-Roller, Cone
8	253-127	2	Seal
9	217-103	12	Bolt-Wheel
10	117-8535	2	Hub-Cupped
10:2	254-66	1	Cup-Bearing, Roller
10:3	254-61	1	Cup-Bearing, Roller
12	32136-1	2	Nut-Slotted

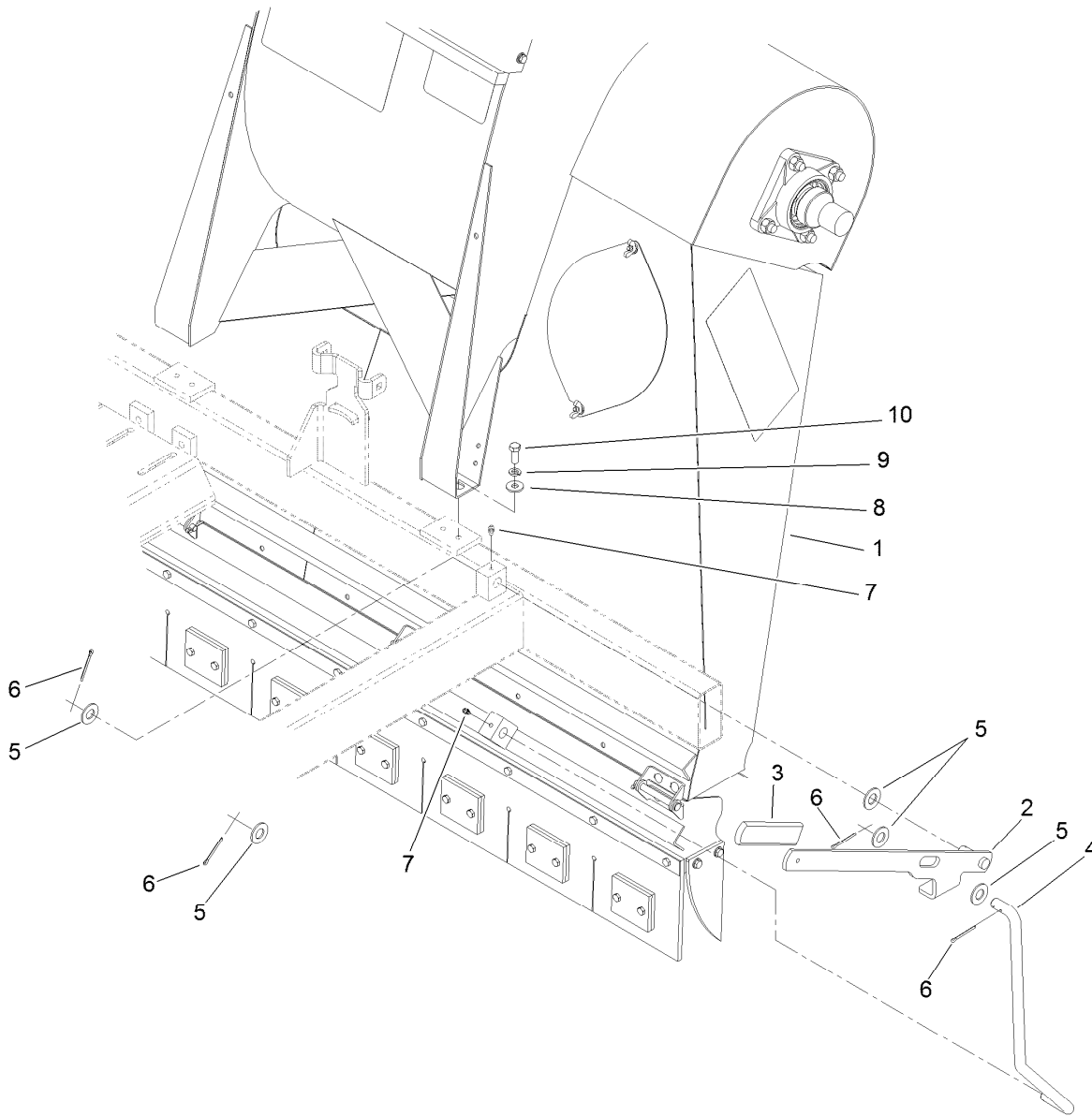

Blower and Throat Mounting Assembly

Ref.	Part Number	Qty.	Description
1		1	Blower And Throat ASM ●
2	119-6205-03	1	Handle-Flap
3	105-3450	1	Grip-Lever, Lift
4	119-2978	1	Rod-Flap Lift
5	3256-27	5	Washer-Flat
6	3272-13	4	Pin-Cotter
7	302-5	2	Fitting-Grease
8	80-6990	8	Washer-Hardened
9	3253-21	8	Washer-Lock
10	323-6	8	Screw-HH

● Not serviced separately

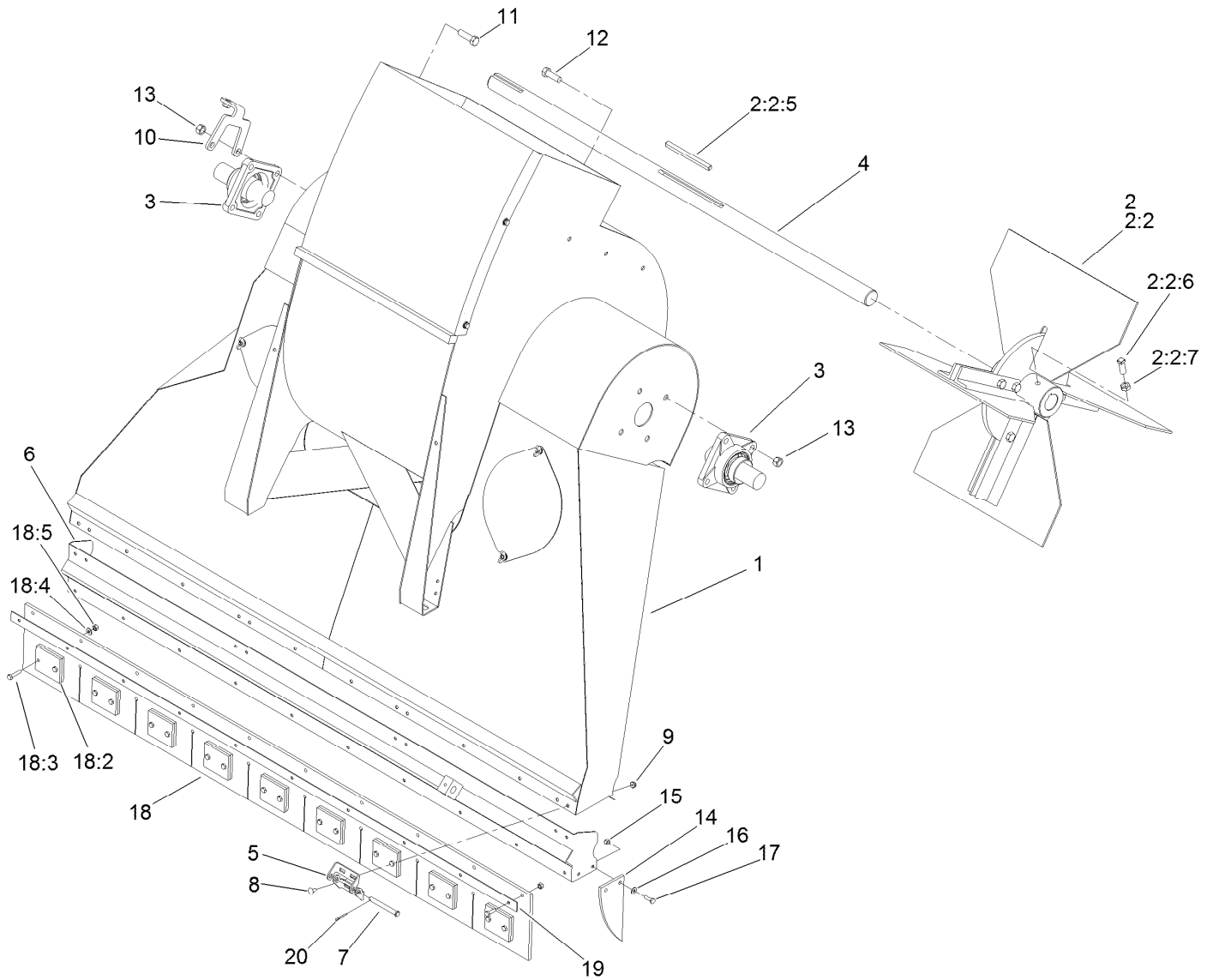

Blower and Throat Assembly

Ref.	Part Number	Qty.	Description	Ref.	Part Number	Qty.	Description
1	13-6280	1	Blower And Throat ASM	11	325-7	4	Screw-HH
2	13-3420-03	1	Fan ASM	12	325-6	4	Screw-HH
2:2		1	Fan ●	13	32153-5	8	Nut-Hex
2:2:5	13-2810	1	Square Key	14	13-3130	2	End-Flap
2:2:6	3244-14	4	Screw-Set, SQH	15	3296-42	4	Nut-Lock, NI
2:2:7	3218-5	4	Nut-Jam	16	3256-22	4	Washer-Flat
3	56-6220	2	Bearing	17	321-5	4	Screw-HH
4	13-3790	1	Fan Shaft	18	13-4700	1	Lower Flap ASM
5	107-1549	8	Hinge-Half	18:2	13-4560-03	18	Weight-Flap
6	119-2995-01	1	Lower Blade Flap ASM	18:3	321-8	18	Screw-HH
7	80-2570	4	Pin-Clevis	18:4	3256-22	18	Washer-Flat
8	3229-11	16	Screw-CARR	18:5	3296-42	18	Nut-Lock, NI
9	104-7201	16	Nut-HF	19	13-1390-01	1	Retainer-Flap
10	108-0893-01	1	Mount-Guard, Fan	20	3272-11	4	Pin-Cotter

● Not serviced separately

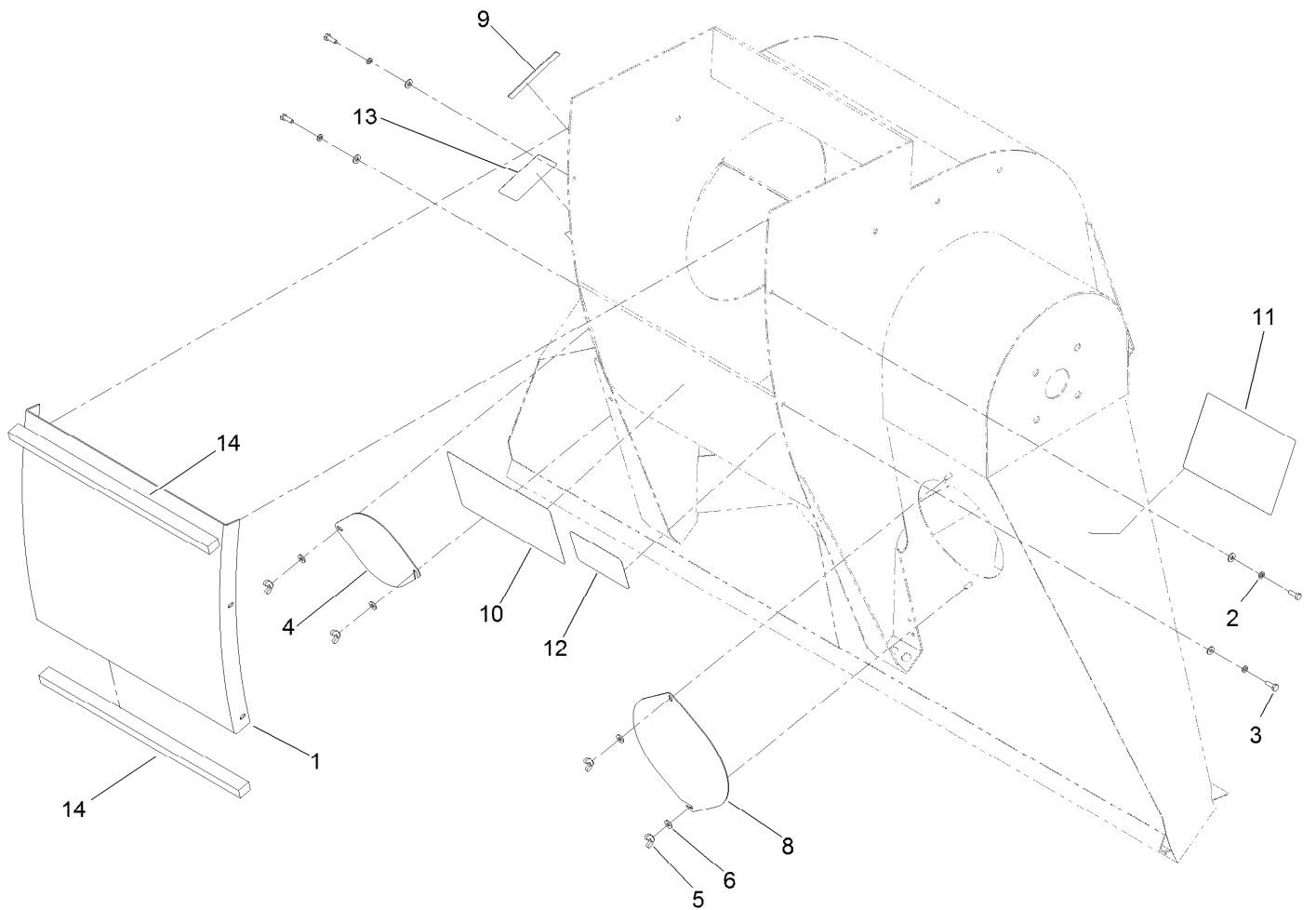

Blower Decal and Cover Assembly

Ref.	Part Number	Qty.	Description
1	13-3850-01	1	Boot-Blower
2	3253-3	4	Washer-Lock
3	321-4	4	Screw-HH
4	13-1420-01	1	Cover-Inspection
5	32103-12	4	Nut-Wing
6	3256-22	8	Washer-Flat
8	93-4020-01	1	Cover-Inspection
9	67-5360	1	Decal-Danger
10	13-6410	1	Decal-Caution
11	93-4041	1	Decal-Instruction
12	93-7307	1	Decal-Warning
13	92-8309	1	Decal-Injury
14	93-7708	2	Strip-Seal

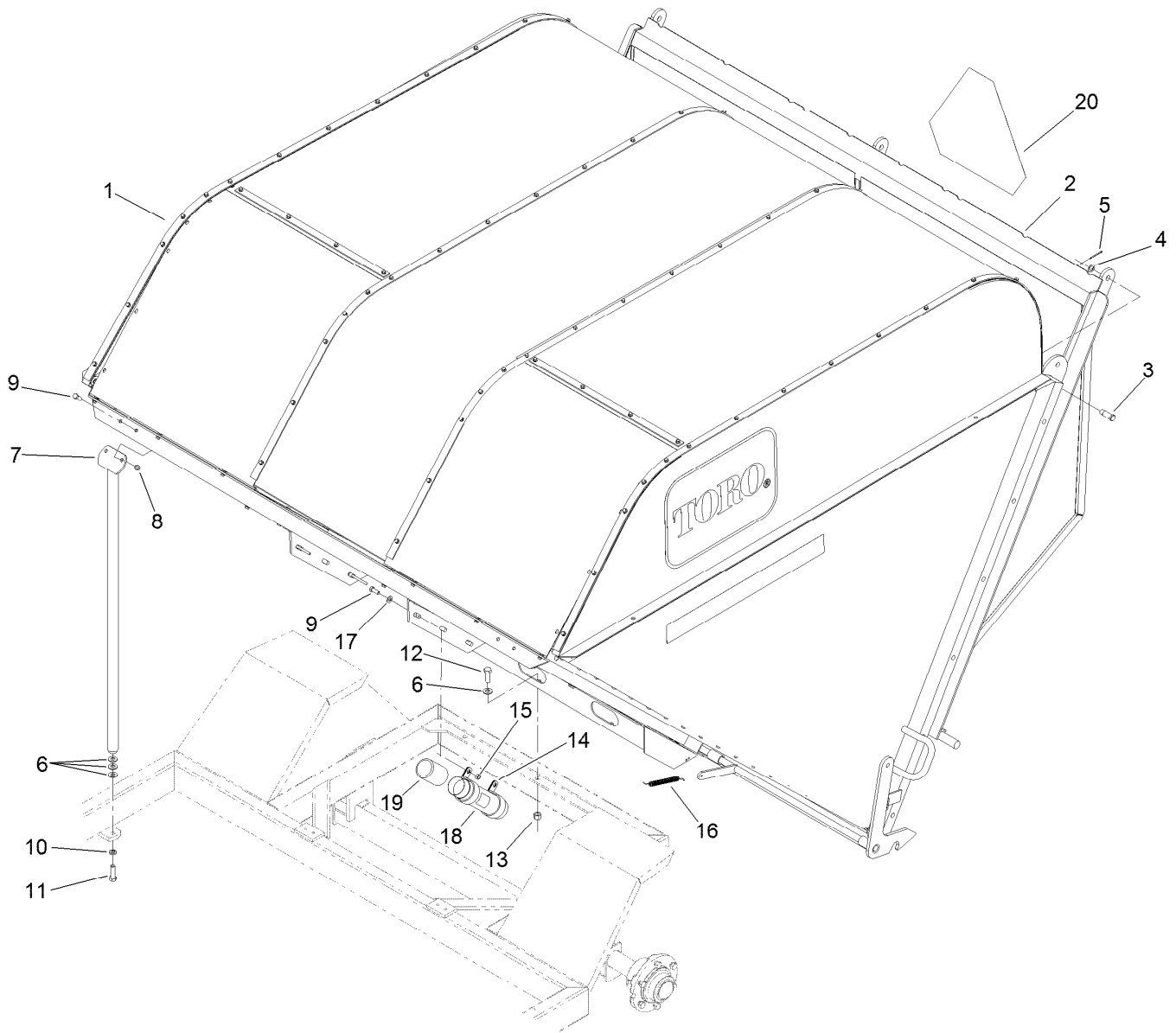

Hopper Mounting Assembly

Ref.	Part Number	Qty.	Description	Ref.	Part Number	Qty.	Description
1		1	Hopper ASM ●	11	325-7	2	Screw-HH
2	119-6268	1	Door-Hopper	12	325-6	3	Screw-HH
3	119-6242	3	Pin-Hinge	13	3296-23	3	Nut-Lock, NI
4	107-3041	3	Washer-Flat	14	2412-133	2	Clamp-R
5	1-806800	3	Pin-Cotter	15	32153-2	2	Nut-Lock, Side
6	3256-26	9	Washer-Flat	16	12-8810	2	Spring-Extension
7	93-4042-01	2	Support-Hopper	17	3256-24	2	Washer-Flat
8	3296-39	4	Nut-Lock, NI	18	104-7050	1	Tube-Manual
9	323-6	6	Screw-HH	19	104-7048	1	Cap-Housing
10	3253-7	2	Washer-Lock	20	13-2930	1	Decal

● Not serviced separately

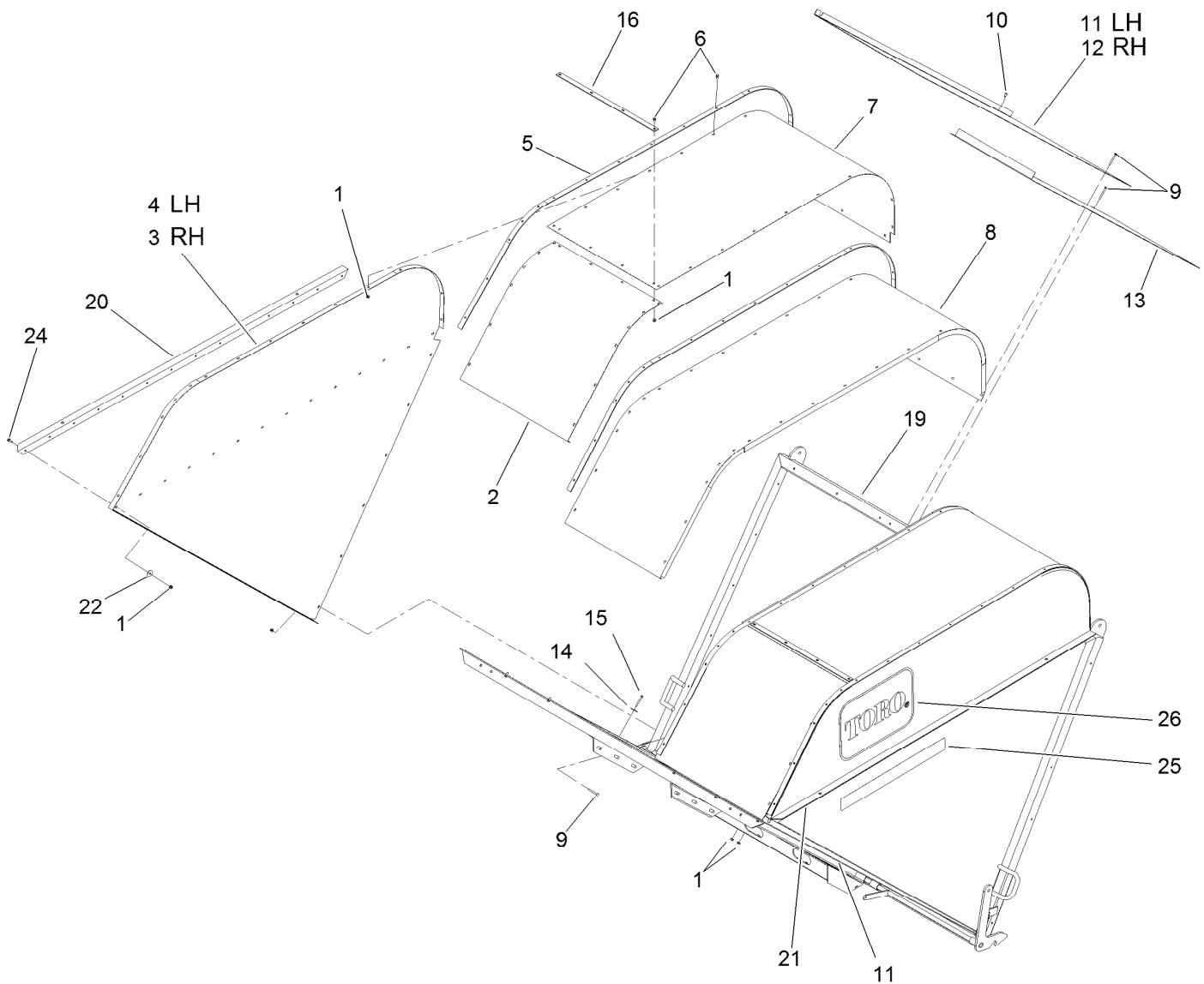

Hopper Assembly

Ref.	Part Number	Qty.	Description	Ref.	Part Number	Qty.	Description
1	32128-32	193	Nut-HHF	14	13-3710	2	Washer
2	94-9128-01	2	Panel-Front	15	3258-165	2	Screw-PRH
3	94-9133-01	1	Panel-Hopper, RH	16	93-4030-01	2	Strap-Hopper, Front
4	94-9129-01	1	Panel-Hopper, LH	17	7420805	38	Vinyl Foam Tape ●
5	93-4031-01	4	Strap-Hopper, Top	19	137-6535	1	Frame ASM
6	3234-33	105	Screw-HHF	20	13-7330	1	Stiffener
7	94-9141-01	2	Screen	21	13-7340	1	Stiffener L
8	94-9135-01	1	Top Panel ASM	22	3256-55	28	Washer-Flat
9	3229-7	50	Screw-CARR	24	3234-33	28	Screw-HHF
10	32122-42	36	Screw	25	93-0184	2	Decal-Hopper
11	94-9139-01	1	Panel-Bottom, LH	26	67-7920	2	Decal
12	94-9137-01	1	Panel-Bottom, RH	27	7420901	27	Vinyl Foam Tape ●
13	94-9138-01	1	Panel-Bottom, Center				

● Not illustrated

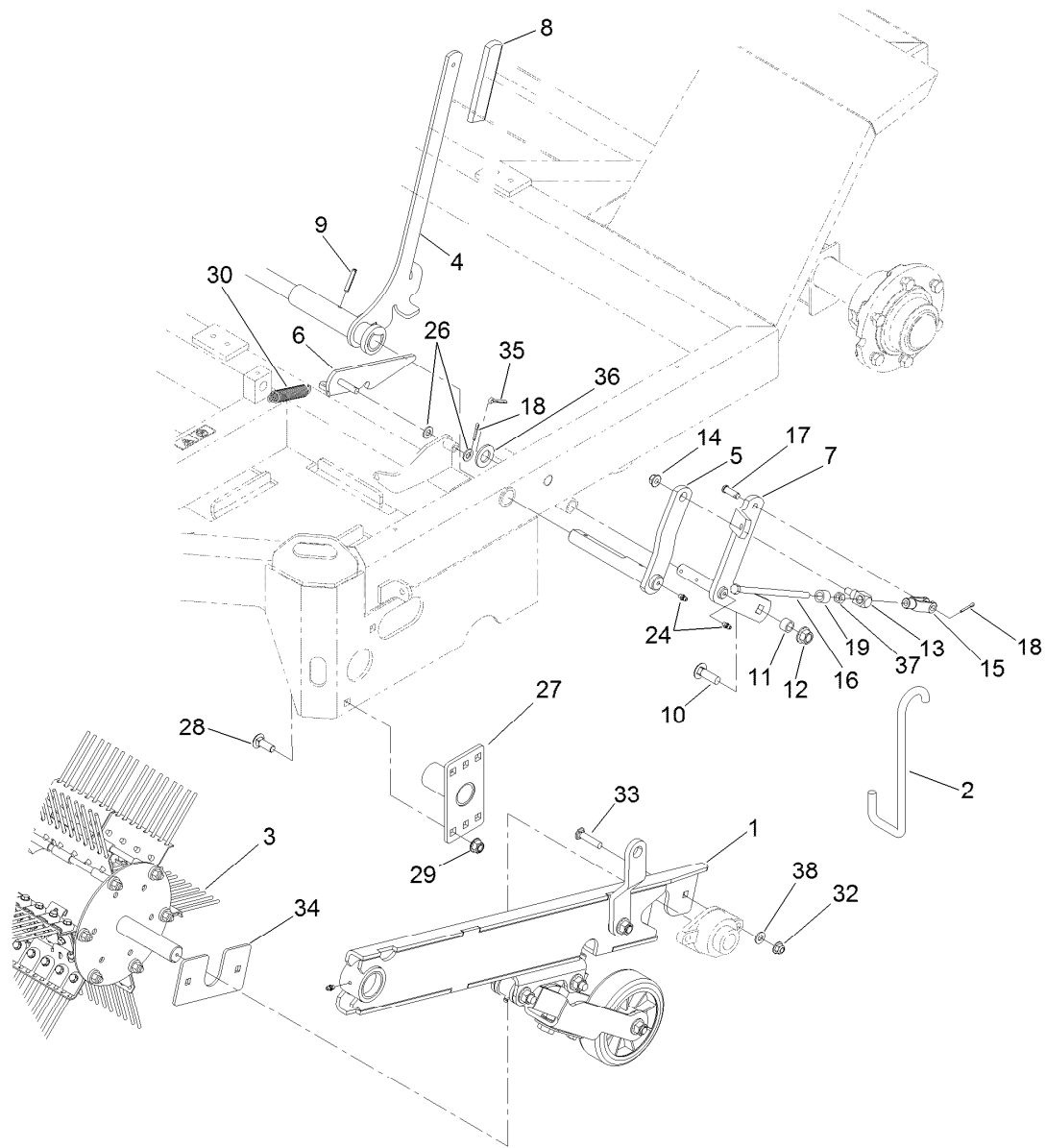

Rake and LH Trailing Arm Assembly

Ref.	Part Number	Qty.	Description	Ref.	Part Number	Qty.	Description
1	117-8470	1	LH Trailing Arm ASM	17	283-2	2	Pin-Clevis
2	120-5986	2	Hook-Transport	18	3272-10	3	Pin-Cotter
3		1	Flex Tip Reel ASM ●	19	95-8603	2	Spacer
4	119-6200-03	1	Handle-Lift	24	302-5	4	Fitting-Grease
5	119-2994-03	2	Crank-Lifting, Rake	26	3256-24	2	Washer-Flat
6	117-8490-03	1	Handle-Trip	27	117-8506-03	1	Mount-Guard
7	117-8503-03	1	Crank-Bell, Lifting LH	28	3232-3	2	Bolt-CARR
8	105-3450	1	Grip-Lever, Lift	29	114-8417	4	Nut-HF, NI
9	32121-15	2	Pin-Roll	30	13-0480	1	Spring
10	3233-2	2	Screw-CARR	32	104-8301	2	Nut-HF, NI
11	119-6188	2	Tube-Pivot	33	3231-29	2	Screw-CARR
12	99-5107	2	Nut-Lock	34	119-6217-03	1	Support-Arm, Trailing
13	13-0100	2	Pivot-Link, Rake Lift	35	3272-22	1	Pin-Cotter
14	104-8301	2	Nut-HF, NI	36	3256-28	1	Washer-Flat
15	282-22	2	Clevis	37	3219-3	2	Nut-Hex
16	27-7900	2	Screw-Adjusting	38	3256-24	2	Washer-Flat

● Not serviced separately

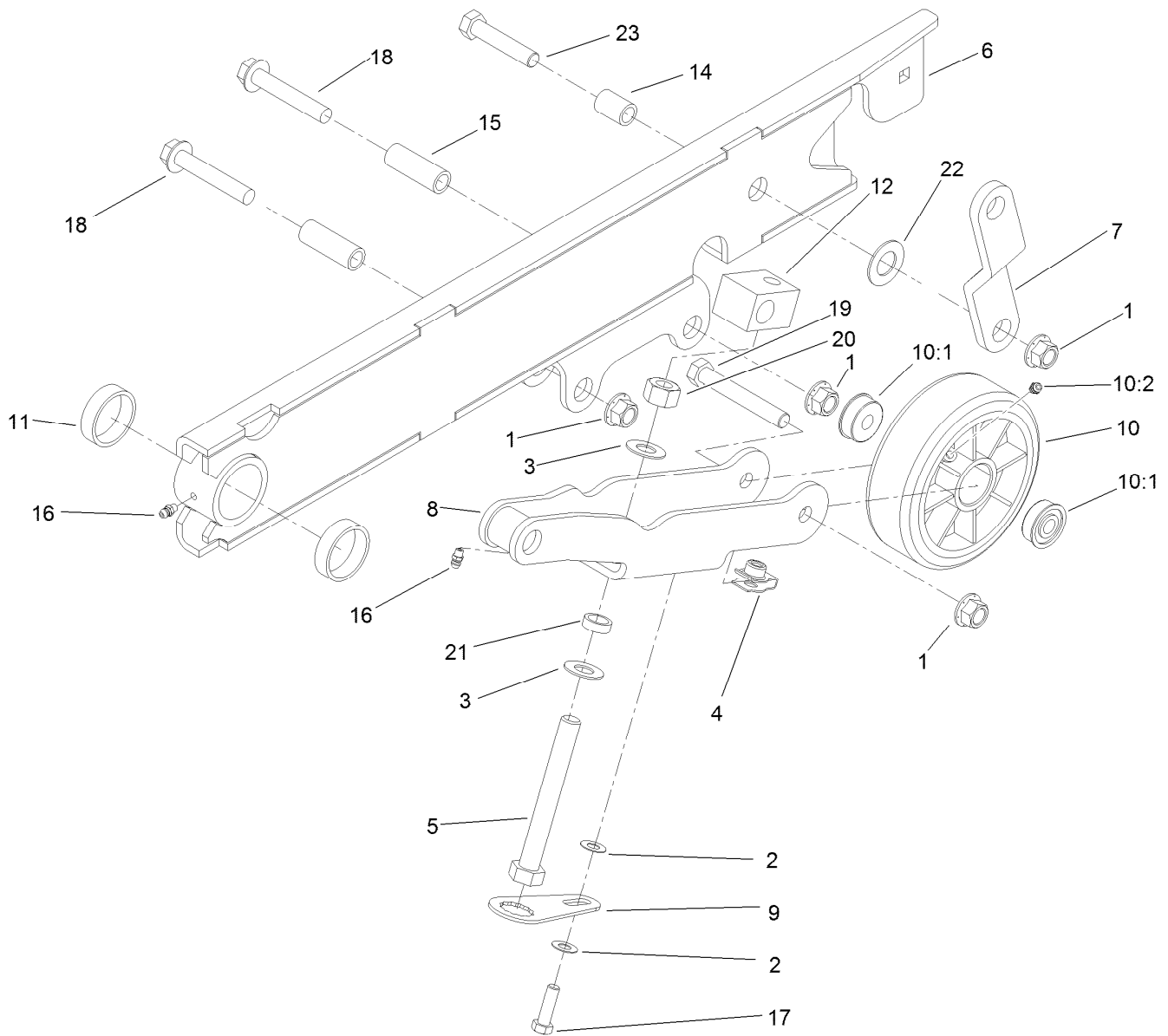

LH Trailing Arm Assembly No. 117-8470

<i>Ref.</i>	<i>Part Number</i>	<i>Qty.</i>	<i>Description</i>	<i>Ref.</i>	<i>Part Number</i>	<i>Qty.</i>	<i>Description</i>
1	99-5107	4	Nut-Lock	11	119-2985	2	Bushing
2	108-1438	2	Washer-Hardened	12	119-6184	1	Block-Pivot
3	99-7667	2	Washer-Flat	14	119-6191	1	Tube-Pivot
4	112-4576	1	Nut-Clip, U	15	119-6192	2	Tube-Pivot
5	112-4874	1	Screw-HH, TAP	16	302-5	2	Fitting-Grease
6	120-5905-03	1	Arm-Trailing	17	323-7	1	Screw-HH
7	117-8465-03	1	Link-Lift	18	3234-40	2	Screw-HF
8	119-6301-03	1	Arm-Gauge, Wheel	19	325-14	1	Screw-HH
9	117-8484	1	Tab-Locking	20	3217-11	1	Nut-Hex
10	117-8544	1	Wheel-Caster	21	119-6253	1	Spacer-Limiter
10:1	119-6254	2	Bearing-Ball	22	69-8930	1	Washer
10:2	302-5	1	Fitting-Grease	23	325-10	1	Screw-HH

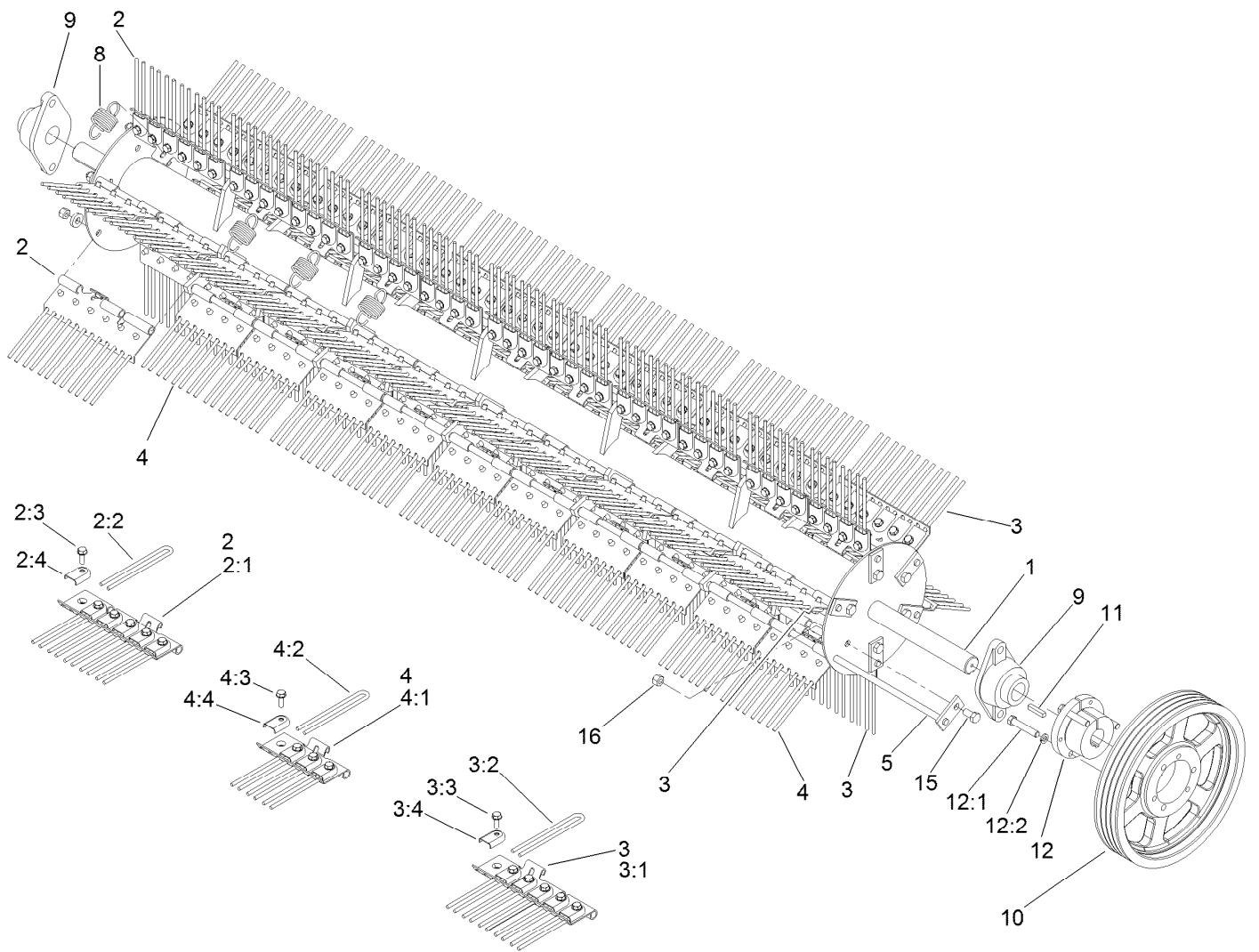

Rake Assembly

Ref.	Part Number	Qty.	Description	Ref.	Part Number	Qty.	Description
1	93-0197-01	1	Reel ASM	4:2	115-9022	4	Finger-Plastic
2		3	Left Plate ASM ●	4:3	32140-94	4	Screw-HH, Sems
2:1	115-9028	1	End Plate ASM	4:4	115-9023	4	Clamp-Finger
2:2	115-9022	6	Finger-Plastic	5	13-4960	6	Shaft-Plate, Finger
2:3	32140-94	6	Screw-HH, Sems	8	13-3090	66	Spring-Finger
2:4	115-9023	6	Clamp-Finger	9	56-6230	2	Bearing-Roller
3		3	Right Plate ASM ●	10	93-4001	1	Pulley-4 Groove
3:1	115-9026	1	End Plate ASM	11	13-2840	1	Key-Square
3:2	115-9022	6	Finger-Plastic	12	13-2680	1	Bushing
3:3	32140-94	6	Screw-HH, Sems	12:1	322-10	3	Screw-HH
3:4	115-9023	6	Clamp-Finger	12:2	3256-23	3	Washer-Plain
4		60	Center Plate ASM ●	15	323-4	6	Screw-HH
4:1	115-9024	1	Plate-Center	16	32152-2	12	Nut-Lock, Cone

● Not serviced separately

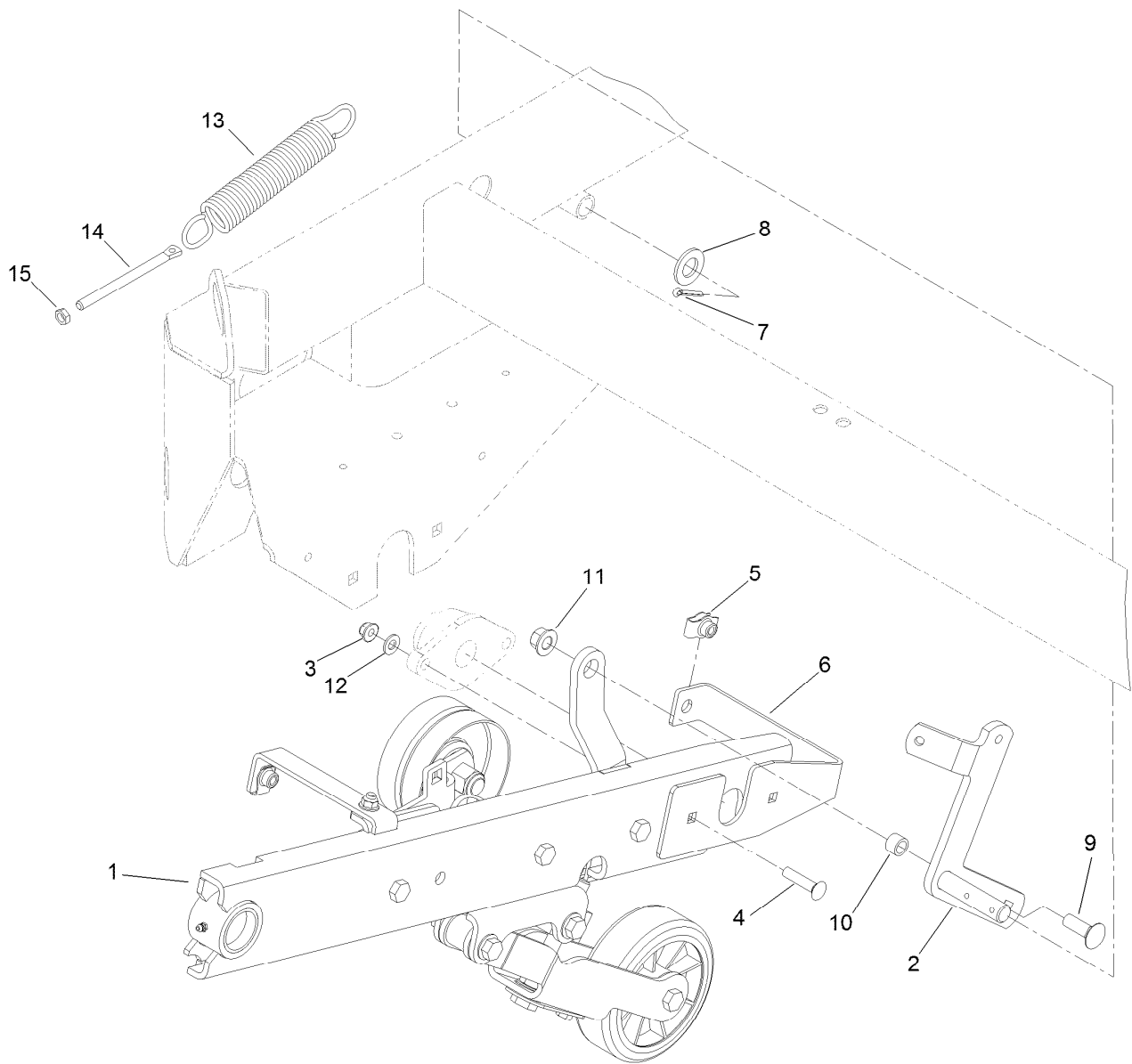

RH Trailing Arm Mounting Assembly

Ref.	Part Number	Qty.	Description
1	117-8460	1	RH Trailing Arm ASM
2	117-8504-03	1	Crank-Bell, Lifting RH
3	104-8301	2	Nut-HF, NI
4	3231-29	2	Screw-CARR
5	112-4576	1	Nut-Clip, U
6	119-6190-03	1	Brace-Cover, Belt
7	3272-22	1	Pin-Cotter
8	3256-28	1	Washer-Flat
9	3233-2	1	Screw-CARR
10	119-6188	1	Tube-Pivot
11	99-5107	1	Nut-Lock
12	3256-24	2	Washer-Flat
13	13-0050	1	Spring-Extension
14	13-5530	1	Rod-Adjust, Spring
15	3218-3	1	Nut-Jam

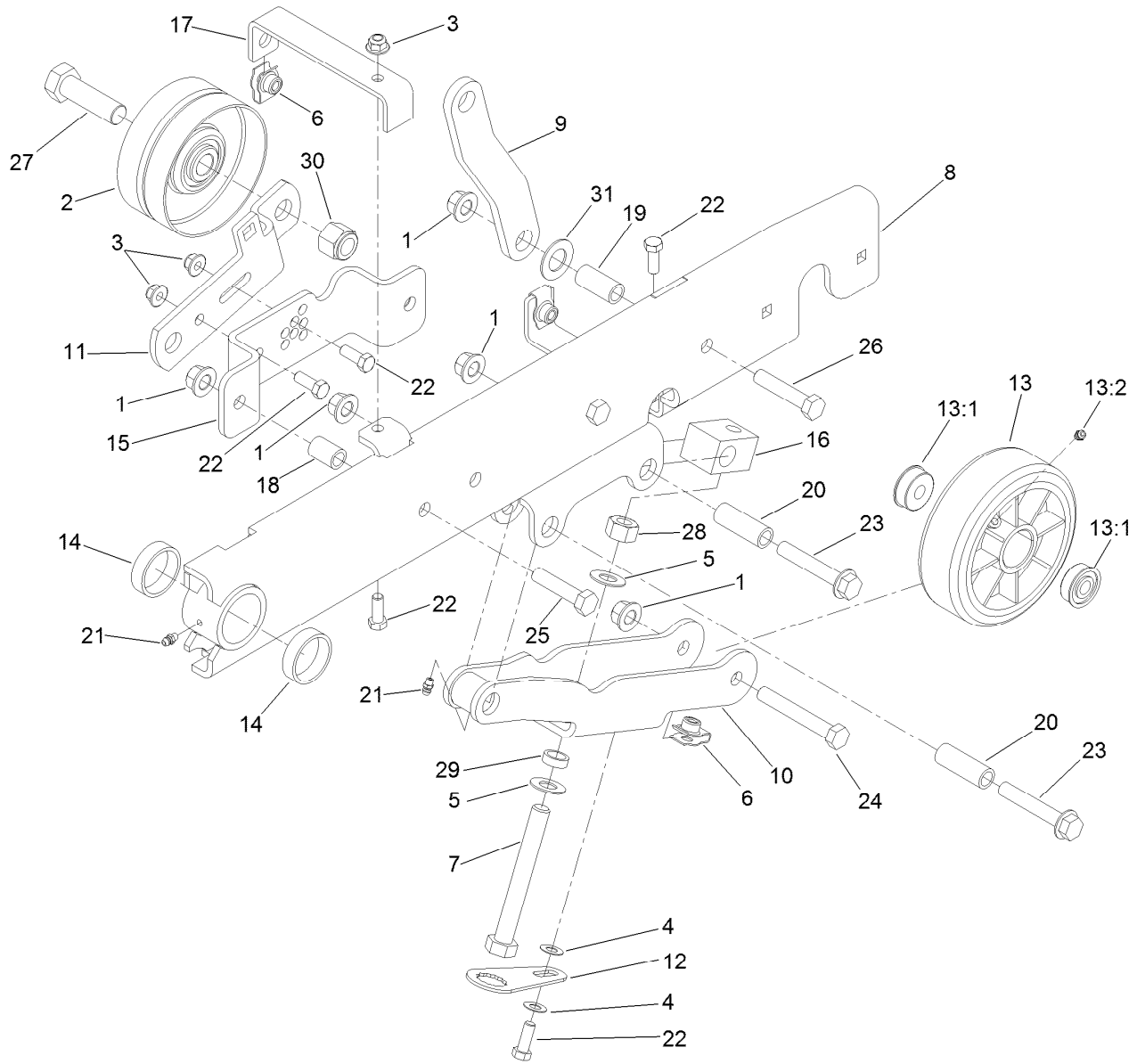

RH Trailing Arm Assembly No. 117-8460

Ref.	Part Number	Qty.	Description	Ref.	Part Number	Qty.	Description
1	99-5107	6	Nut-Lock	16	119-6184	1	Block-Pivot
2	100-7631	1	Pulley-Idler	17	119-6187-03	2	Brace-Cover
3	104-8301	4	Nut-HF, NI	18	119-6189	2	Tube-Pivot
4	108-1438	2	Washer-Hardened	19	119-6191	1	Tube-Pivot
5	99-7667	2	Washer-Flat	20	119-6192	2	Tube-Pivot
6	112-4576	3	Nut-Clip, U	21	302-5	2	Fitting-Grease
7	112-4874	1	Screw-HH, TAP	22	323-6	5	Screw-HH
8	117-8461-03	1	Arm-Trailing	23	3234-40	2	Screw-HF
9	117-8465-03	1	Link-Lift	24	325-14	1	Screw-HH
10	119-6301-03	1	Arm-Gauge, Wheel	25	325-9	2	Screw-HH
11	117-8469-03	1	Bracket-Pulley	26	325-10	1	Screw-HH
12	117-8484	1	Tab-Locking	27	328-2	1	Screw-HH
13	117-8544	1	Wheel-Caster	28	3217-11	1	Nut-Hex
13:1	119-6254	2	Bearing-Ball	29	119-6253	1	Spacer-Limiter
13:2	302-5	1	Fitting-Grease	30	3296-51	1	Nut-Lock, NI
14	119-2985	2	Bushing	31	69-8930	1	Washer
15	119-2992-03	1	Bracket-Adjust,Tension				

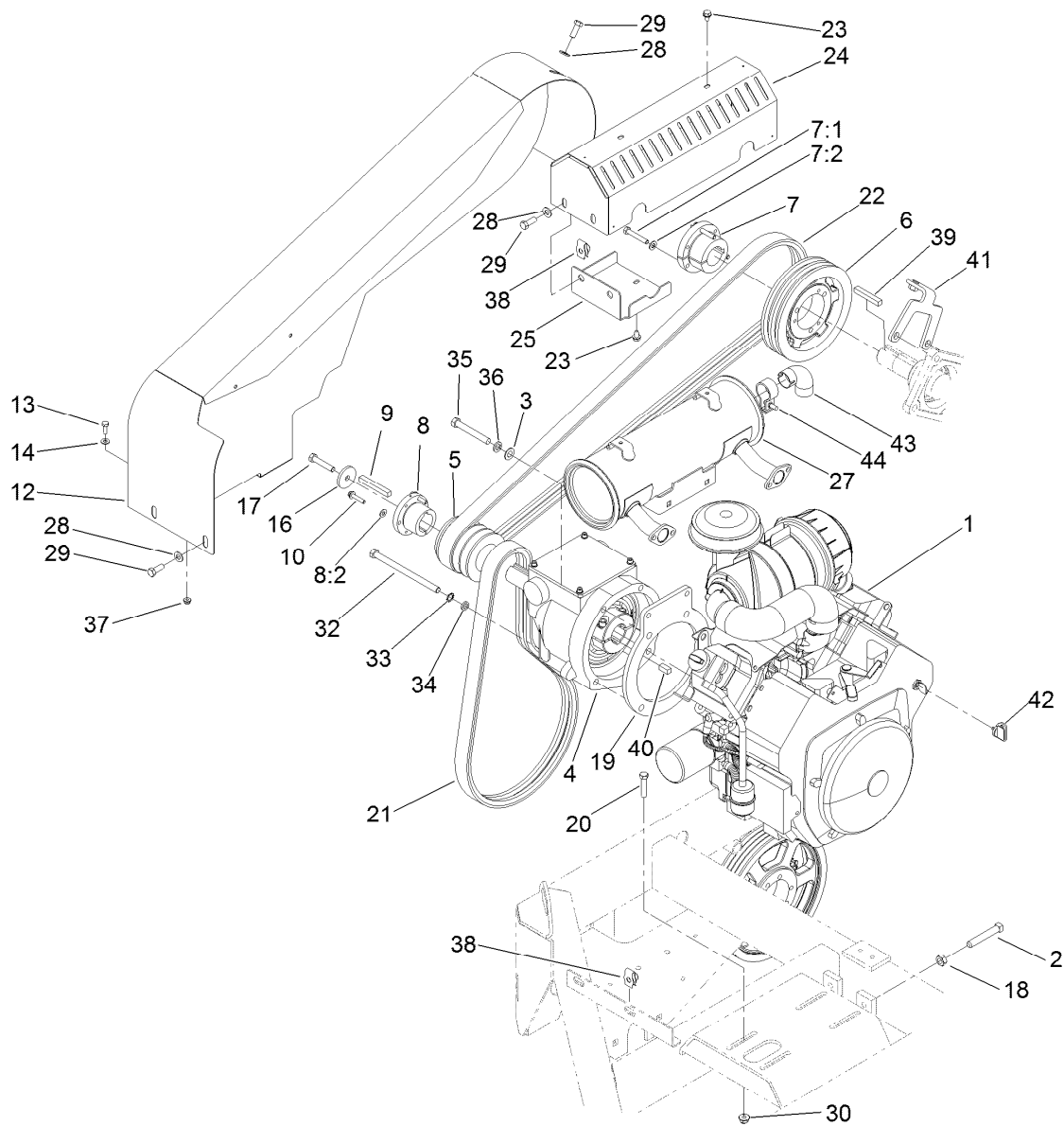

Engine, Clutch and Muffler Assembly

Ref.	Part Number	Qty.	Description	Ref.	Part Number	Qty.	Description
1		1	Engine-Kohler, Ch680-Ps660062 ■▲	16	4-1920	1	Washer
1:1	108-3847	1	Filter-Oil ●	17	323-10	1	Screw-HH
2	3244-21	2	Screw-SQH	18	3218-5	2	Nut-Jam
3	3256-25	2	Washer-Flat	19	119-6137-03	1	Plate-Adapter
4	107-1050	1	Clutch-Centrifugal	20	323-9	4	Screw-HH
5	13-3320	1	Sheave	21	13-2650	1	Belt-V
6	13-2800	1	Sheave	22	93-0183	1	Belt-V, Impeller
7	13-2970	1	Bushing	23	32104-82	3	Screw-HHF
7:1	120-6000	3	Bolt-TAP, HH	24	119-6221-03	1	Shield-Heat
7:2	3253-3	3	Washer-Lock	25	119-6222-03	1	Cap-Bottom, Heat Shield
8	13-3330	1	Bushing	27	119-6106	1	Muffler ASM
8:2	3253-4	3	Washer-Lock	28	3256-24	5	Washer-Flat
9	3-9155	1	Key-Square	29	323-6	5	Screw-HH
10	321-6	3	Screw-HH	30	104-8301	4	Nut-HF, NI
12	119-6271	1	Guard-Fan Belt	32	324-31	2	Screw-HH
13	321-4	2	Screw-HH	33	3255-16	2	Washer-Lock/EXT
14	3256-22	2	Washer-Flat	34	37-4700	2	Spacer-Wheel
				35	324-13	2	Screw-HH

● Not illustrated

▲ Obtain parts from www.kohlerplus.com

■ Not serviced separately

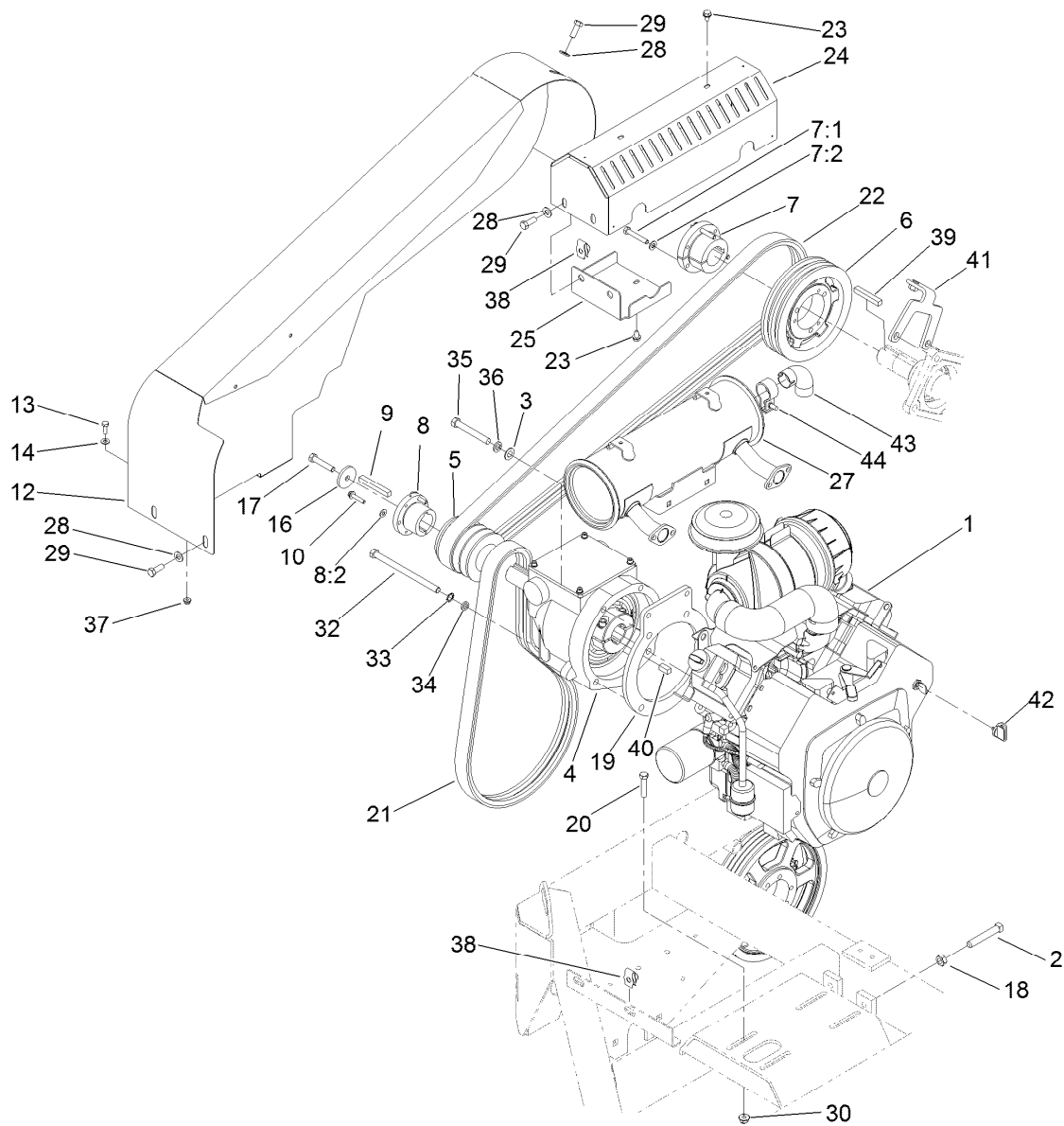

Engine, Clutch and Muffler Assembly (continued)

<i>Ref.</i>	<i>Part Number</i>	<i>Qty.</i>	<i>Description</i>	<i>Ref.</i>	<i>Part Number</i>	<i>Qty.</i>	<i>Description</i>
36	3253-6	2	Washer-Lock	41	108-0893-01	1	Mount-Guard, Fan
37	104-7201	2	Nut-HF	42	63-8360	1	Key-Ignition
38	105-4886	4	Nut-Tinnerman	43	95-4797	1	Exhaust-Outlet, 90 DEG
39	13-2240	1	Key-Square	44	103-1514	1	Clamp-Muffler
40	105-7864	1	Key-Square				

● Not illustrated
▲ Obtain parts from www.kohlerplus.com

■ Not serviced separately

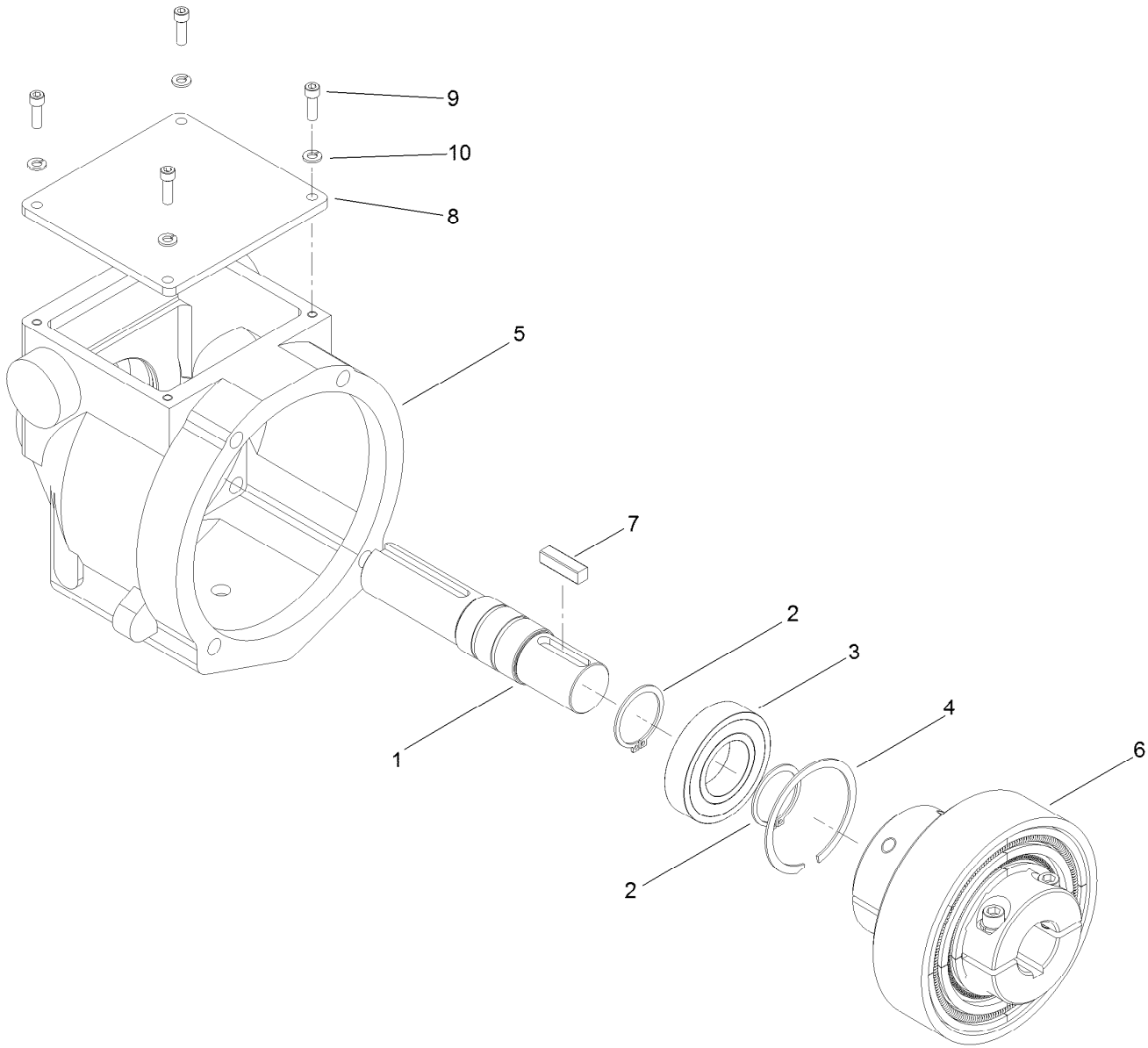

Centrifugal Clutch Assembly No. 107-1050

Ref.	Part Number	Qty.	Description
1	107-1052	1	Shaft
2	107-1053	2	Ring-Retaining
3	107-1054	1	Bearing
4	107-1055	1	Ring-Retaining
5		1	Housing ●
6	107-1070	1	Centrifugal Clutch ASM
7	107-1057	1	Key
8	107-1058	1	Cover
9	3274-8	4	Screw-HSH
10	3253-3	4	Washer-Lock

● Not serviced separately

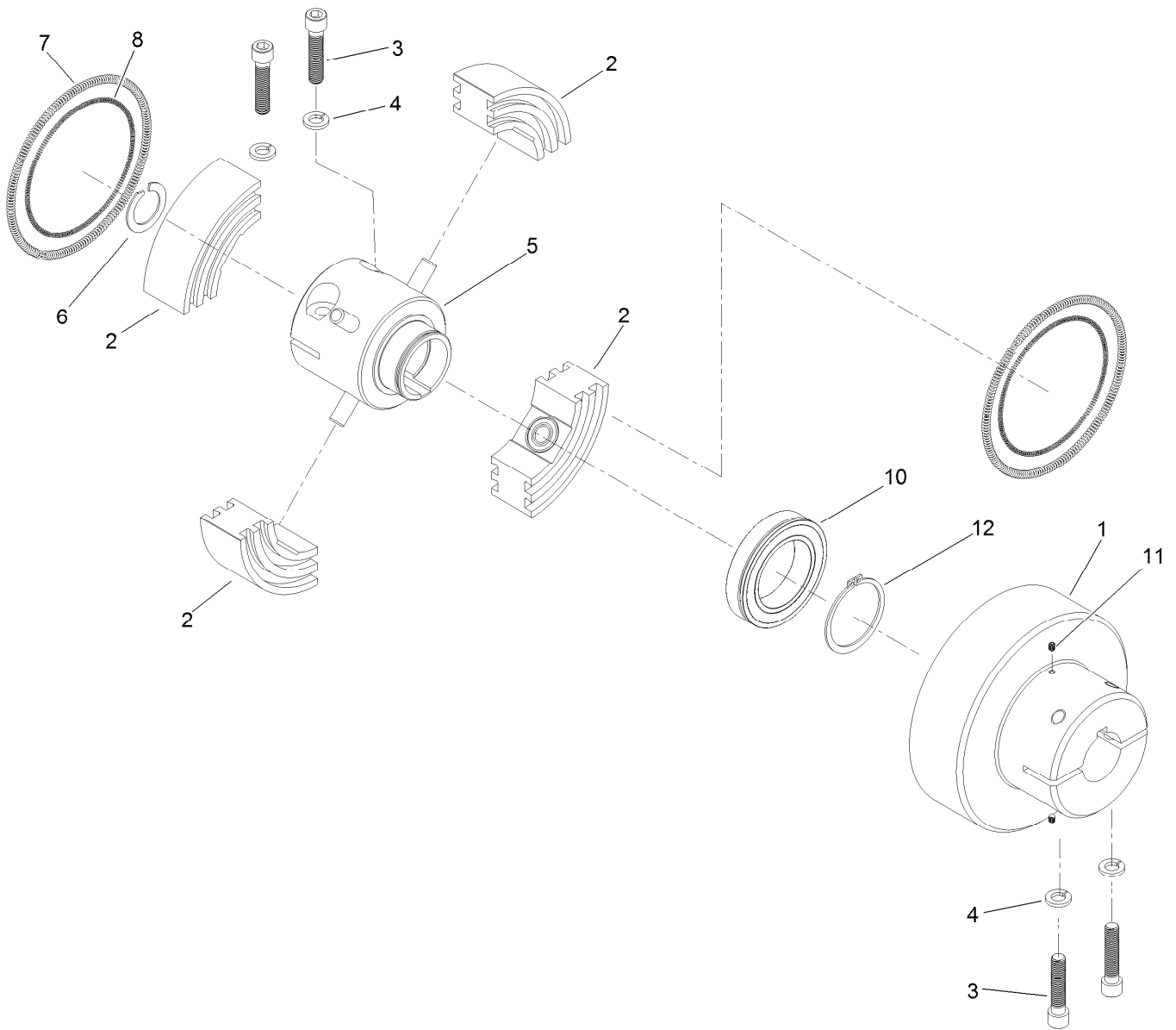

Clutch Assembly No. 107-1070

Ref.	Part Number	Qty.	Description
1		1	Housing-Clutch ●
2	107-1072	4	Shoe ASM
3	3274-3	4	Screw-HSH
4	3253-21	4	Washer-Lock
5	107-1081	1	Hub ASM
6	107-1074	1	Ring-Retaining
7	107-1075	2	Spring
8	107-1076	2	Spring
10	107-1078	1	Bearing
11	107-1079	2	Point-Cone
12	107-1080	1	Ring-Retaining

● Not serviced separately

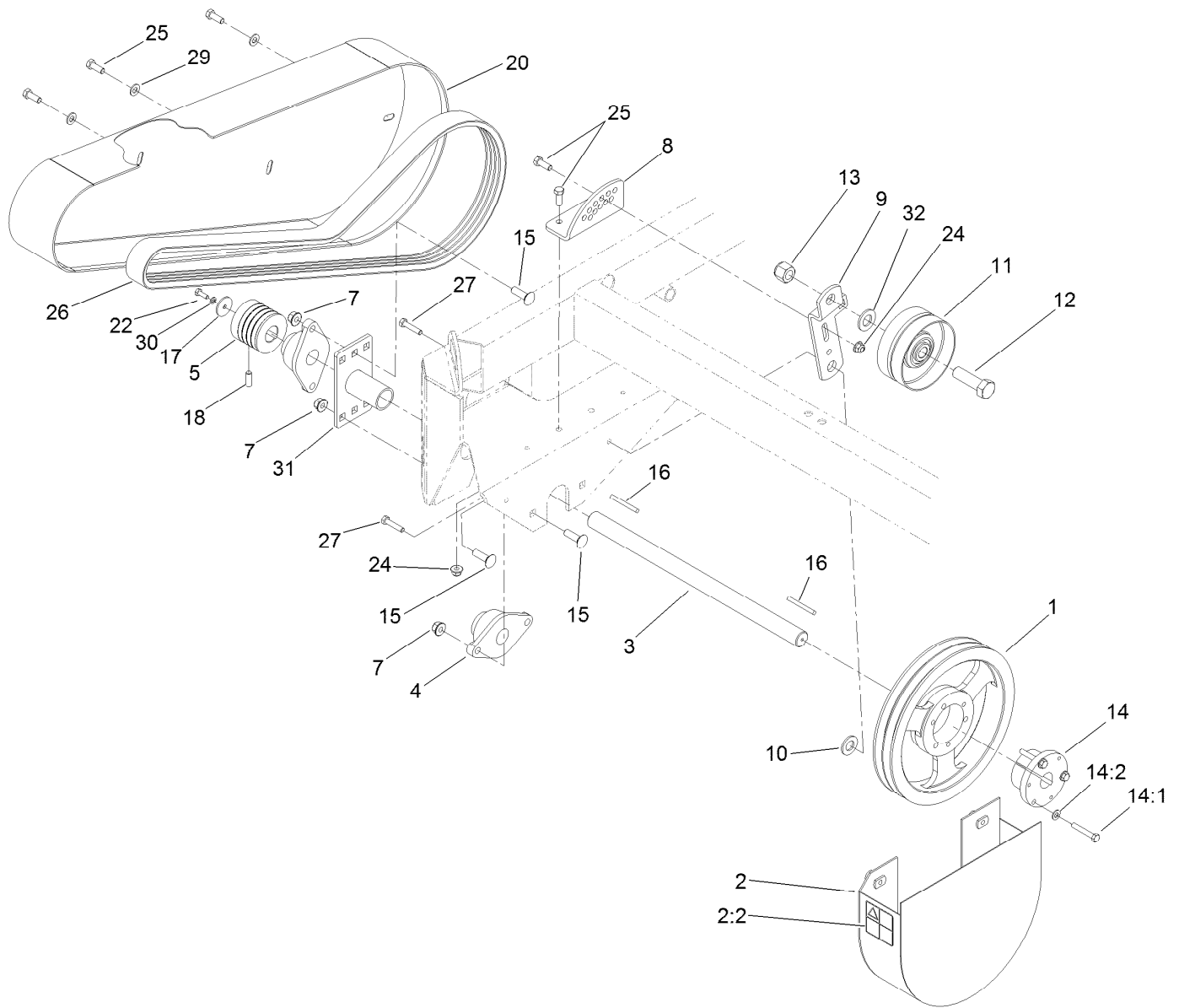

Idler, Pully and Belt Assembly

Ref.	Part Number	Qty.	Description	Ref.	Part Number	Qty.	Description
1	13-2670	1	Sheave	14:2	3256-23	3	Washer-Plain
2	119-6267	1	Sheave Guard	15	3232-3	6	Bolt-CARR
2:2	105-4586	1	Decal-Shield	16	68-3220	2	Key-Stock
3	93-4032	1	Shaft-Jack	17	13-3710	1	Washer
4	56-6230	2	Bearing-Roller	18	3247-6	2	Screw-Set
5	93-4033	1	Pulley-Driver	20	119-6266	1	Guard-Lower Belt
7	114-8417	6	Nut-HF, NI	22	321-4	1	Screw-HH
8	117-8538-03	1	Bracket-Idler Arm	24	104-8301	3	Nut-HF, NI
9	117-8469-03	1	Bracket-Pulley	25	323-6	6	Screw-HH
10	3-8448	1	Washer-Thrust	26	93-4034	1	V-Belt
11	100-7631	1	Pulley-Idler	27	322-7	2	Screw-HH
12	328-25	1	Screw-HH	29	3256-24	3	Washer-Flat
13	3296-51	1	Nut-Lock, NI	30	3253-3	1	Washer-Lock
14	13-2680	2	Bushing	31	117-8506-03	1	Mount-Guard
14:1	322-10	3	Screw-HH	32	3256-28	2	Washer-Flat

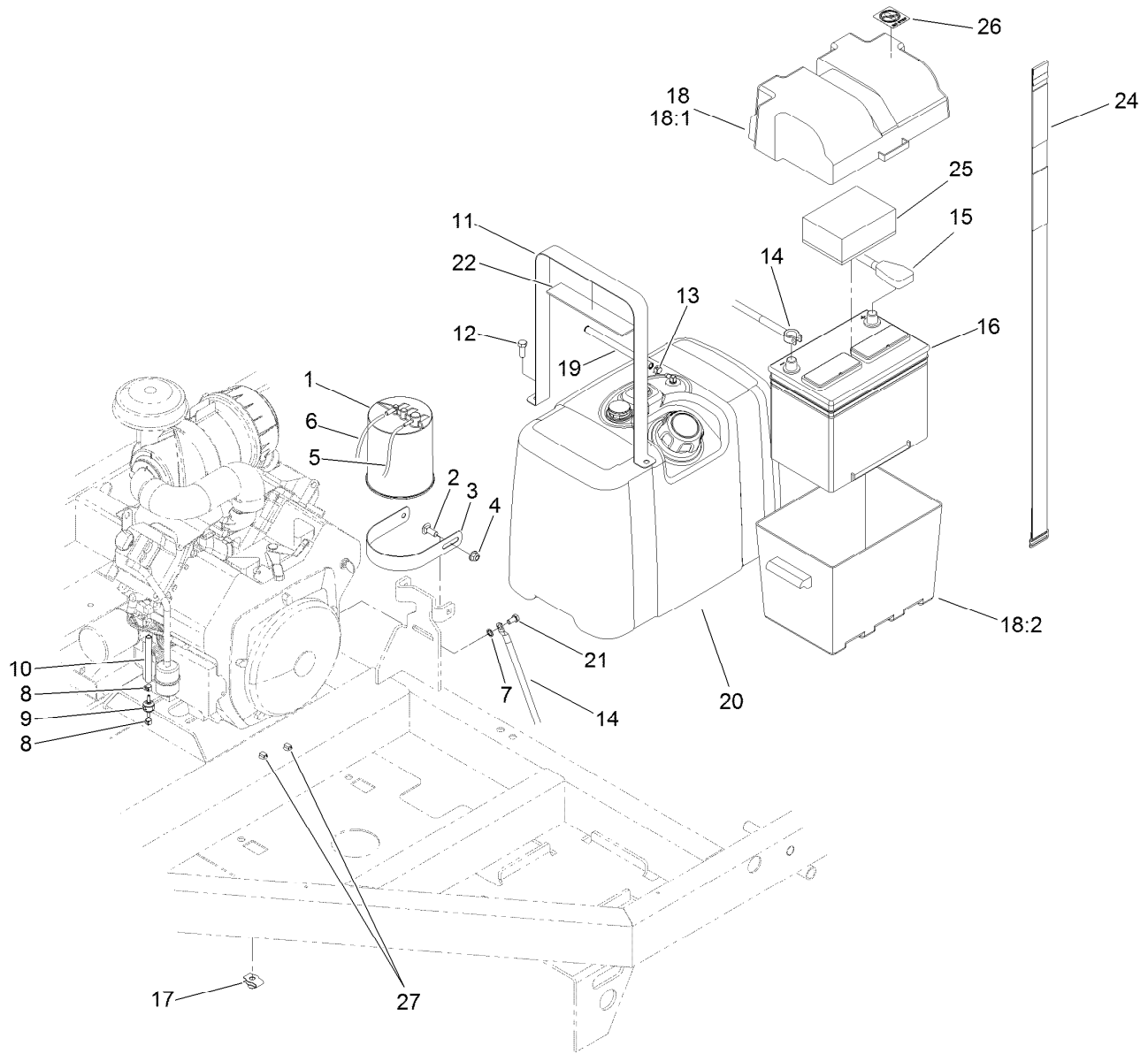

Fuel Tank and Battery Assembly

<i>Ref.</i>	<i>Part Number</i>	<i>Qty.</i>	<i>Description</i>	<i>Ref.</i>	<i>Part Number</i>	<i>Qty.</i>	<i>Description</i>
1	114-0289	1	Canister-Carbon	15	112-6808	1	Cable-Battery, Positive
2	3231-2	2	Bolt-CARR	16	106-5190	1	Battery
3	117-8399	1	Strap-Mounting	17	105-4886	4	Nut-Tinnerman
4	104-8301	2	Nut-HF, NI	18	93-7595	1	Battery Box ASM
5	110-3254	1	Hose-Fuel	18:1	105-2914	1	Top-Battery Box
6	115-7872	1	Hose-Fuel	18:2	105-2915	1	Bottom-Battery Box
7	3254-2	1	Washer-Lock, Internal	19	109-1395	1	Hose-Fuel
8	2412-80	2	Clamp-Hose	20	117-8454	1	Fuel Tank ASM
9	115-7868	1	Valve-Check, Vacuum	21	33114-016	1	Screw-HH
10	115-7871	1	Hose-Fuel	22	104-7102	2	Pad-Battery
11	119-2965	2	Strap-Tank	24	94-1445	1	Strap-Battery
12	323-6	4	Screw-HH	25	93-7968	1	Pad-Foam
13	2412-98	2	Clamp-Hose	26	61-5950	1	Decal-No Step
14	120-5908	1	Cable-Battery, Negative	27	32180-030	4	Clip-Tie

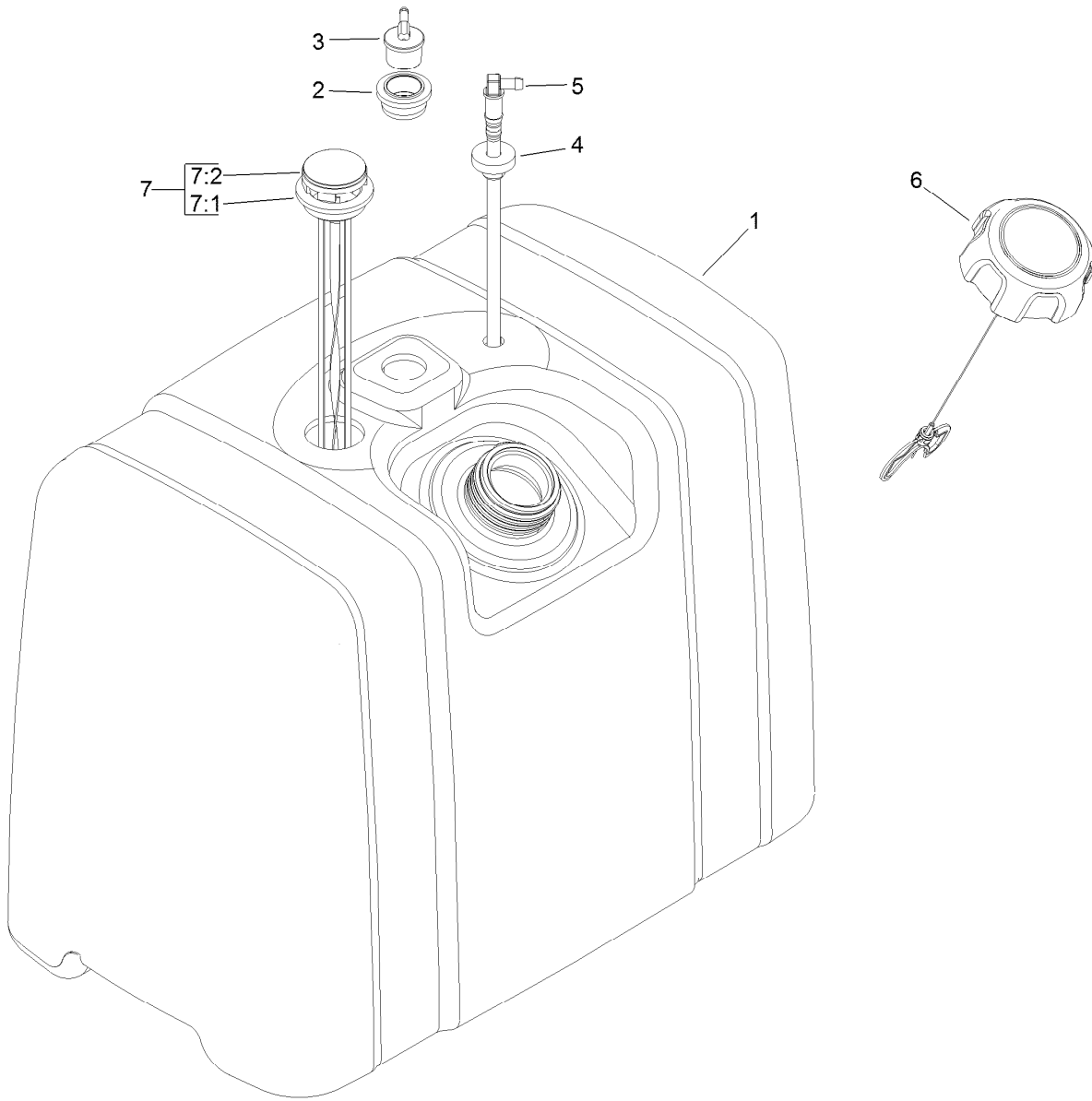

Fuel Tank Assembly No. 117-8454

Ref.	Part Number	Qty.	Description
1	117-8452	1	Tank-Fuel
2	114-0284	1	Grommet
3	114-0285	1	Valve-Rollover
4	46-6560	1	Bushing
5	115-9046	1	Stand Pipe
6	115-7788	1	Cap-Fuel
7	119-0507	1	Gauge-Fuel
7:1	119-0508	1	Seal
7:2	117-8404	1	Dial-Gauge

Attachments and Accessories

For 07050 66in Rake-O-Vac Sweeper

Product Name

Model/Part

Spark Arrestor Screen 94-8157



Count on it.