



**Count on it.**

**Operator's Manual**

# STX-26 Stump Grinder

Model No. 23208—Serial No. 40200000 and Up

Model No. 23208G—Serial No. 40200000 and Up

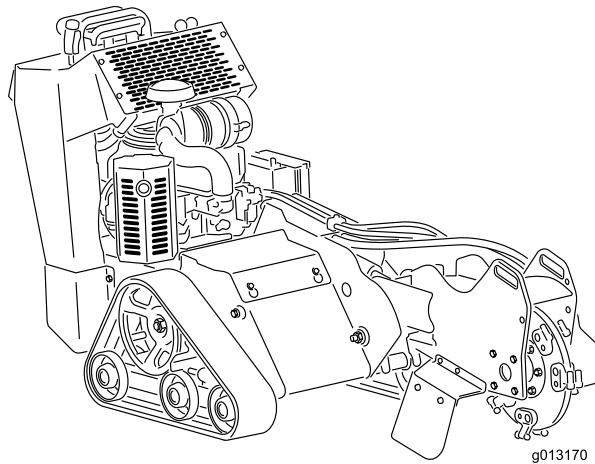

g013170



This product complies with all relevant European directives; for details, please see the separate product specific Declaration of Conformity (DOC) sheet.

It is a violation of California Public Resource Code Section 4442 or 4443 to use or operate the engine on any forest-covered, brush-covered, or grass-covered land unless the engine is equipped with a spark arrester, as defined in Section 4442, maintained in effective working order or the engine is constructed, equipped, and maintained for the prevention of fire.

The enclosed engine owner's manual is supplied for information regarding the US Environmental Protection Agency (EPA) and the California Emission Control Regulation of emission systems, maintenance, and warranty. Replacements may be ordered through the engine manufacturer.

## **⚠ WARNING**

### **CALIFORNIA Proposition 65 Warning**

**The engine exhaust from this product contains chemicals known to the State of California to cause cancer, birth defects, or other reproductive harm.**

**Battery posts, terminals, and related accessories contain lead and lead compounds, chemicals known to the State of California to cause cancer and reproductive harm. Wash hands after handling.**

**Use of this product may cause exposure to chemicals known to the State of California to cause cancer, birth defects, or other reproductive harm.**

# Introduction

This machine is designed to grind and remove tree stumps and surface roots. It is not intended to cut rock or any other material other than wood and the soil around a stump.

Read this information carefully to learn how to operate and maintain your product properly and to avoid injury and product damage. You are responsible for operating the product properly and safely.

You may contact Toro directly at [www.Toro.com](http://www.Toro.com) for product safety and operation training materials, accessory information, help finding a dealer, or to register your product.

Whenever you need service, genuine Toro parts, or additional information, contact an Authorized Service Dealer or Toro Customer Service and have the model and serial numbers of your product ready. [Figure 1](#) illustrates the location of the model and serial numbers on the product. Write the numbers in the space provided.

**Important:** With your mobile device, you can scan the QR code on the serial number decal (if equipped) to access warranty, parts, and other product information.

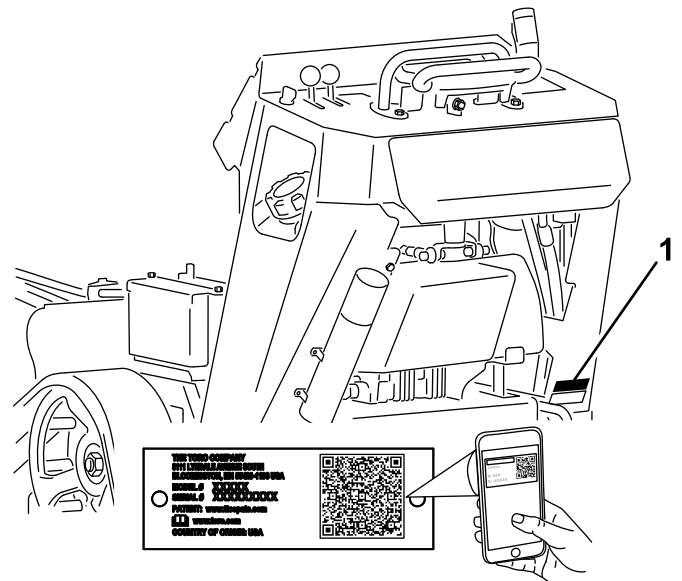

**Figure 1**

g242084

1. Model and serial number plate

Model No. \_\_\_\_\_

Serial No. \_\_\_\_\_

This manual identifies potential hazards and has safety messages identified by the safety-alert symbol

(Figure 2), which signals a hazard that may cause serious injury or death if you do not follow the recommended precautions.



Figure 2

g000502

1. Safety-alert symbol

This manual uses 2 words to highlight information. **Important** calls attention to special mechanical information and **Note** emphasizes general information worthy of special attention.

# Contents

Safety .....	4
Safe Operating Practices .....	4
Safety and Instructional Decals .....	6
Setup .....	10
1 Installing the Grinder Control Lever .....	10
2 Checking the Fluid Levels .....	10
3 Charging the Battery .....	10
Product Overview .....	11
Controls .....	11
Specifications .....	14
Attachments/Accessories .....	14
Operation .....	14
Adding Fuel .....	14
Performing Daily Maintenance .....	16
Starting the Engine .....	16
Driving the Machine .....	17
Shutting off the Engine .....	17
Grinding a Stump .....	17
Moving a Non-Functioning Machine .....	18
Securing the Machine for Transport .....	18
Lifting the Machine .....	19
Operating Tips .....	19
Maintenance .....	20
Recommended Maintenance Schedule(s) .....	20
Pre-Maintenance Procedures .....	21
Removing the Cover Plate .....	21
Removing the Bottom Shield .....	21
Lubrication .....	22
Greasing the Machine .....	22
Engine Maintenance .....	23
Servicing the Air Cleaner .....	23
Servicing the Engine Oil .....	24
Servicing the Spark Plug(s) .....	26
Fuel System Maintenance .....	27
Draining the Fuel Tank .....	27
Replacing the Fuel Filter .....	28
Electrical System Maintenance .....	28
Servicing the Battery .....	28
Replacing the Fuses .....	31

Drive System Maintenance .....	31
Servicing the Tracks .....	31
Belt Maintenance .....	34
Replacing the Pump-Drive Belt .....	34
Controls System Maintenance .....	35
Adjusting the Traction-Control Alignment .....	35
Hydraulic System Maintenance .....	37
Hydraulic Fluid Specifications .....	37
Checking the Hydraulic-Fluid Level .....	37
Changing the Hydraulic Fluid .....	38
Grinder Maintenance .....	39
Replacing the Teeth .....	39
Cleaning .....	40
Removing Debris from the Machine .....	40
Storage .....	40
Troubleshooting .....	42
Schematics .....	43

# Safety

Improper use or maintenance by the operator or owner can result in injury. To reduce the potential for injury, comply with these safety instructions and always pay attention to the safety-alert symbol (Figure 2), which means **Caution**, **Warning**, or **Danger**—personal safety instruction. Failure to comply with the instruction may result in personal injury or death.

## **⚠ DANGER**

**There may be buried power, gas, and/or telephone lines in the work area. Digging into them may cause a shock or an explosion.**

**Have the property or work area marked for buried lines and do not dig in marked areas. Contact your local marking service or utility company to have the property marked (for example, in the US, call 811 or in Australia, call 1100 for the nationwide marking service).**

## Safe Operating Practices

This product is capable of amputating hands and feet. Always follow all safety instructions to avoid serious injury or death.

## **⚠ WARNING**

**Engine exhaust contains carbon monoxide, an odorless poison that is fatal if inhaled.**

**Do not run the engine indoors or in an enclosed area.**

## Training

- Read the *Operator's Manual* and other training material. If the operator(s) or mechanic(s) cannot read this information, it is the owner's responsibility to explain this material to them.
- Become familiar with the safe operation of the equipment, operator controls, and safety signs.
- All operators and mechanics should be trained. The owner is responsible for training the users.
- Never let children or untrained people operate or service the equipment. Local regulations may restrict the age of the operator.
- The owner/user can prevent and is responsible for accidents or injuries occurring to himself or herself, other people or property.

## Preparation

- Before using the machine, have the area marked for underground utilities and do not use the machine in marked areas.

- Evaluate the terrain to determine what accessories and attachments you need to properly and safely perform the job. Use only the accessories and attachments that are approved by the manufacturer.
- Wear appropriate clothing including gloves, eye protection, long pants, substantial slip-resistant footwear, and hearing protection. Tie back long hair and do not wear loose clothing or loose jewelry.
- Inspect the area where you will use the equipment and remove all objects, such as rocks, toys, and wire, that the machine could throw.
- Check that the operator's presence controls, safety switches, and shields are attached and functioning properly. Do not operate the machine unless they are functioning properly.

## Fuel Safety

- Use extra care when handling fuel. It is flammable and its vapors are explosive.
- Extinguish all cigarettes, cigars, pipes, and other sources of ignition.
- Use only an approved fuel container.
- Do not remove the fuel cap or fill the fuel tank while the engine is running or hot.
- Do not add or drain fuel in an enclosed space.
- Do not store the machine or fuel container where there is an open flame, spark, or pilot light, such as on a water heater or other appliance.
- If you spill fuel, do not attempt to start the engine; avoid creating any source of ignition until the fuel vapors have dissipated.

## Operation

- Use your full attention while operating the machine. Do not engage in any activity that causes distractions; otherwise, injury or property damage may occur.
- **Clean debris from the hydraulic lift, drives, mufflers, and engine after each use to help prevent fires.**
- Park the machine on a level surface, lower the hydraulic lift, disengage the hydraulics, engage the parking brake (if applicable), shut off the engine, and remove the key before leaving the operator's position for any reason.
- Do not touch parts that may be hot from operation. Allow them to cool before attempting to maintain, adjust, or service the machine.
- Never run an engine in an enclosed area.
- Operate the machine only in good light, keeping away from holes and hidden hazards.

- Ensure that all the drives are in neutral and the parking brake is engaged (if applicable) before starting the engine. Start the engine only from the operator's position.
- Slow down and use extra care on hillsides. Ensure to travel in the recommended direction on hillsides. Turf conditions can affect the stability of the machine.
- Slow down and use caution when making turns, crossing roads and sidewalks, and when changing directions on slopes.
- Do not change the engine-governor setting or overspeed the engine.
- Keep your hands and feet away from moving parts.
- Look behind and down before backing up to ensure that the path is clear.
- Never carry passengers and keep pets and bystanders away.
- Do not operate the machine when you are tired, ill, or under the influence of alcohol or drugs.
- Use care when loading or unloading the machine into a trailer or truck.
- Use care when approaching blind corners.
- Ensure that the area is clear of people before operating the machine. Stop the machine if anyone enters the area.
- Never jerk the controls; use a steady motion.
- Operate the machine in areas where there are no obstacles in close proximity to you. Failure to maintain adequate distance from trees, walls, and other barriers may result in injury as the machine backs up during operation if you are not attentive to the surroundings. Operate the machine only in areas where there is sufficient clearance for you to safely maneuver.
- Locate the pinch point areas marked on the machine and keep your hands and feet away from these areas.
- Lightning can cause severe injury or death. If lightning is seen or thunder is heard in the area, do not operate the machine; seek shelter.

## Slope Operation

- Slopes are a major factor related to loss-of-control and tip-over accidents, which can result in severe injury or death. The operator is responsible for safe slope operation. operating the machine on any slope requires extra caution. Before using the machine on a slope, you must:
  - Review and understand the slope instructions in the manual and on the machine.
  - Evaluate the site conditions of the day to determine if the slope is safe for machine operation. Always use common sense

and good judgment when performing this evaluation. Changes in the terrain, such as moisture, can quickly affect the operation of the machine on a slope.

- **Operate up and down slopes with the front of the machine uphill.**
- Identify hazards at the base of the slope. Do not operate the machine near drop-offs, ditches, embankments, water or other hazards. The machine could suddenly roll over if a wheel or track goes over the edge or the edge collapses. Keep a safe distance (twice the width of the machine) between the machine and any hazard.
- Avoid starting, stopping, or turning the machine on a slope. Avoid making sudden changes in speed or direction; turn slowly and gradually.
- Keep all movements on slopes slow and gradual. Do not make sudden changes in speed or direction.
- Do not operate the machine under any conditions where traction, steering, or stability is in question. Be aware that operating the machine on wet grass, across slopes or downhill may cause the machine to lose traction. Loss of traction to the wheels or tracks may result in sliding and a loss of braking and steering. The machine can slide even if the wheels or tracks are stopped.
- Identify hazards at the base of the slope. Do not operate the machine near drop-offs, ditches, embankments, water or other hazards. The machine could suddenly roll over if a wheel or track goes over the edge or the edge collapses. Keep a safe distance (twice the width of the machine) between the machine and any hazard.
- Remove or mark obstacles such as ditches, holes, ruts, bumps, rocks or other hidden hazards. Tall grass can hide obstacles. Uneven terrain could overturn the machine.
- Do not park the machine on a hillside or slope without lowering the hydraulic lift to the ground.

## Maintenance and Storage

- Park the machine on a level surface, lower the hydraulic lift, disengage the hydraulics, engage the parking brake (if applicable), shut off the engine, and remove the key. Wait for all moving parts to stop before adjusting, cleaning, or repairing the machine.
- Clean debris from the hydraulic lift, drives, mufflers, and engine to help prevent fires. Wipe up any spilled oil or fuel.
- Allow the engine to cool before storing and do not store the machine near flames.
- Never allow untrained personnel to service the machine.

- Use jack stands to support the components when required.
- Carefully release pressure from components with stored energy.
- Keep your hands and feet away from the moving parts. If possible, do not make adjustments with the engine running.
- Disconnect the battery or remove the spark-plug wires before making any repairs. Disconnect the negative terminal first and the positive last; connect the positive first and the negative last.
- Charge the battery in an open, well-ventilated area, away from spark and flames. Unplug the charger before connecting or disconnecting it from the battery. Wear protective clothing and use insulated tools.
- Battery acid is poisonous and can cause burns. Avoid contact with skin, eyes, and clothing. Protect your face, eyes, and clothing when working with a battery.
- Battery gasses can explode. Keep cigarettes, sparks, and flames away from the battery.
- Keep all parts in good working condition and all hardware tightened. Replace all worn or damaged decals.
- Keep all nuts and bolts tight. Keep the equipment in good condition.
- Never tamper with the safety devices.
- Keep the machine free of debris buildup. Wipe up any spilled oil or fuel.
- Shut off the engine, remove the key, and inspect the machine if you strike an object. Make any necessary repairs before starting.
- Use only genuine Toro replacement parts.
- Keep your body and hands away from pinhole leaks or nozzles that eject high-pressure hydraulic fluid. Use cardboard or paper to find hydraulic leaks; never use your hands. Hydraulic fluid escaping under pressure can penetrate skin and cause injury requiring surgery within a few hours by a qualified surgeon; otherwise, gangrene may result.

## Safety and Instructional Decals



Safety decals and instructions are easily visible to the operator and are located near any area of potential danger. Replace any decal that is damaged or missing.

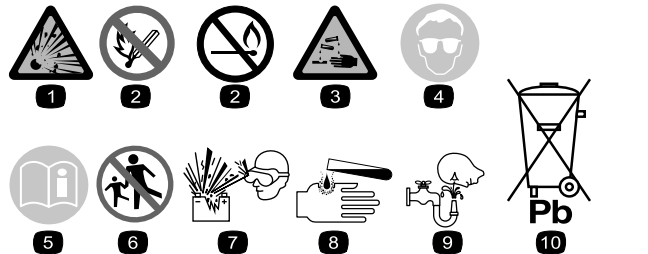

decalbatterysymbols

### Battery Symbols

Some or all of these symbols are on your battery.

- |  |   |
|--|---|
| 1. Explosion hazard                    | 6. Keep bystanders a safe distance from the battery.                            |
| 2. No fire, open flame, or smoking     | 7. Wear eye protection; explosive gases can cause blindness and other injuries. |
| 3. Caustic liquid/chemical burn hazard | 8. Battery acid can cause blindness or severe burns.                            |
| 4. Wear eye protection.                | 9. Flush eyes immediately with water and get medical help fast.                 |
| 5. Read the <i>Operator's Manual</i> . | 10. Contains lead; do not discard   |



decal93-6686

93-6686

1. Hydraulic fluid
2. Read the *Operator's Manual*.



decal93-7321

93-7321

1. Cutting/dismemberment hazard of hands and feet, rotating knives/blades—stay away from moving parts.

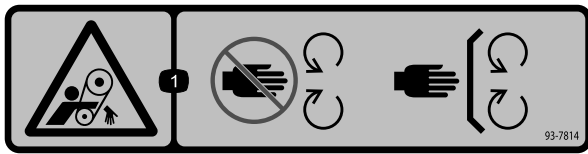

93-7814

decal93-7814

1. Entanglement hazard, belt—stay away from moving parts; keep all guards and shields in place.

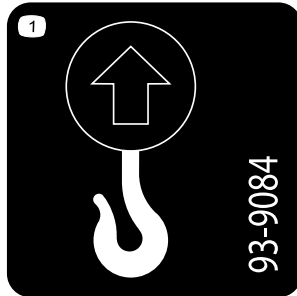

93-9084

decal93-9084

1. Lift point/Tie-down point

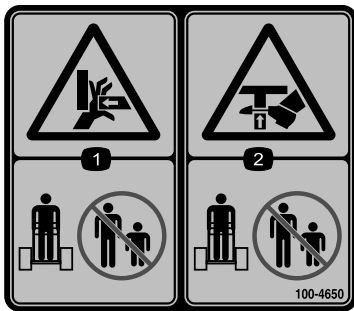

100-4650

decal100-4650

1. Crushing hazard of hand—keep bystanders a safe distance away from the machine.
2. Crushing hazard of foot—keep bystanders a safe distance away from the machine.

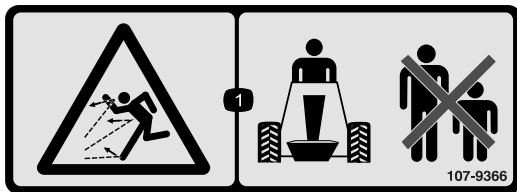

107-9366

decal107-9366

1. Thrown object hazard—keep bystanders a safe distance away from the machine.

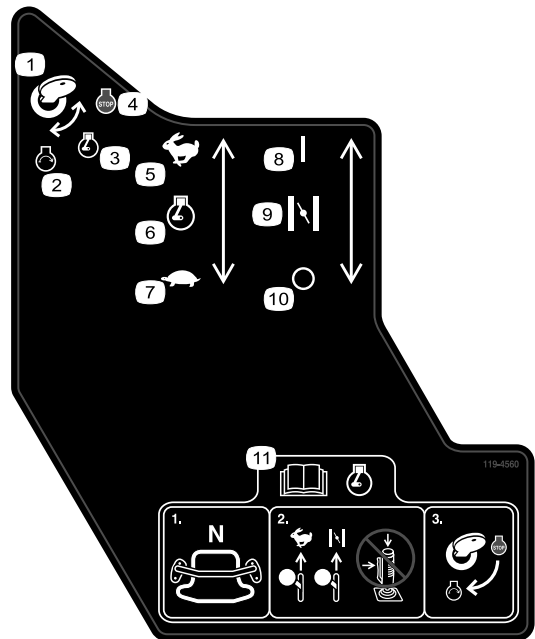

119-4560

decal119-4560

1. Ignition key
2. Engine—start
3. Engine—run
4. Engine—stop
5. Fast
6. Engine speed
7. Slow
8. On/Closed
9. Choke
10. Off/Open
11. Read the *Operator's Manual* before starting the engine—1) Ensure that the traction control is in the NEUTRAL position; 2) Move the throttle lever to the FAST position, close the choke (if applicable), and do not operate the joystick; 3) Turn the key to start the engine.

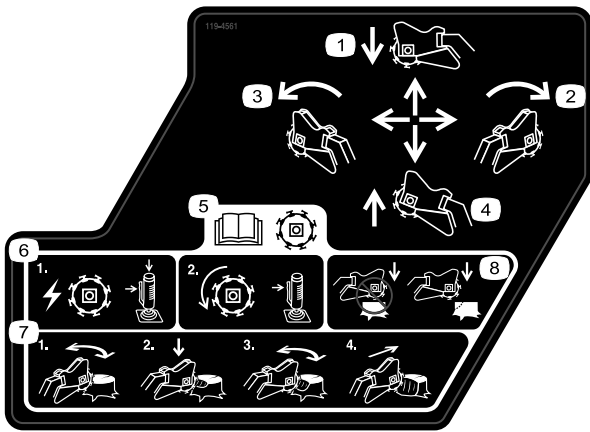

119-4561

decal119-4561

1. Push forward to lower the stump grinder.
2. Move right to move the stump grinder to the right.
3. Pull back to raise the stump grinder.
4. Move left to move the stump grinder to the left.
5. Read the *Operator's Manual* before operating the cutter; engage the side lever and top button of the joystick to start the cutter blade; continue engaging the side lever to maintain cutter rotation.
6. 1) To power the grinder, press the safety lock and the trigger together; 2) To keep the grinder running, hold the trigger.
7. 1) Grind horizontally along the edge of the stump; 2) Lower the grinder slightly into the stump; 3) Grind horizontally down to ground level; 4) Move the grinder forward.
8. Do not start grinding in the middle of the stump; start grinding at the edge of the stump.

**WARNING:** Cancer and Reproductive Harm - [www.P65Warnings.ca.gov](http://www.P65Warnings.ca.gov). For more information, please visit [www.toro.com/CAProp65](http://www.toro.com/CAProp65)

**CALIFORNIA SPARK ARRESTER WARNING**

Operation of this equipment may create sparks that can start fires around dry vegetation. A spark arrester may be required. The operator should contact local fire agencies for laws or regulations relating to fire prevention requirements.

133-8056

decal133-8056

**STX-26 MODEL 23208 QUICK REFERENCE AID**

**CHECK/SERVICE (DAILY)**

1. OIL LEVEL, ENGINE
2. OIL LEVEL, HYDRAULIC TANK
3. BELT
4. AIR CLEANER
5. BRAKE FUNCTION
6. GREASE - LUBE POINTS (8)

**SPECIFICATIONS/CHANGE INTERVALS**

SEE OPERATOR'S MANUAL FOR INITIAL CHANGES.	FLUID TYPE	CAPACITY	CHANGE INTERVAL		FILTER TORQUE
			FLUID	FILTER	
Ⓐ ENGINE OIL	SAE 10W-30, SAE 10W-40	51 OZ (1.5 L) w/o FILTER 59 OZ (1.7 L) w/ FILTER	100 HRS	200 HRS	3/4 TURN PAST FIRST CONTACT
Ⓑ HYDRAULIC OIL	TORO PREMIUM HYD FLUID TORO PREMIUM TRACTOR FLUID	6 GAL (23 L)	400 HRS	200 HRS	110-140 in-lbs 13-15.5 Nm
Ⓒ AIR FILTER	—	—	—	250 HRS	—
Ⓓ FUEL FILTER	—	—	—	200 HRS	—
Ⓔ FUEL	UNLEADED GASOLINE	4.8 GAL (18 L)	—	—	—

**SERVICE PARTS**

DESCRIPTION / LOCATION	PART NO.
BELT	114-2991
FILTER - OIL	119-5352
FILTER - FUEL	121-4370
FILTER - AIR (OUTER)	119-5944
FILTER - HYDRAULIC (IN TANK)	114-3039
TRACK - RUBBER	112-4816
WHEEL TENSIONER	112-4817
GASKET - BOGIE	106-7585
GRINDER TOOTH KIT	115-9385
POCKET - ANGLED	115-9384
POCKET - STRAIGHT	115-9388

137-3875

decal137-3875

1. Read the *Operator's Manual*.

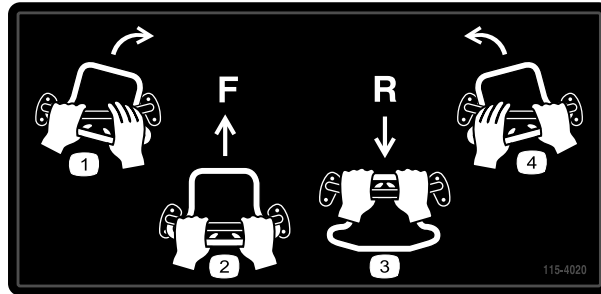

115-4020

decal115-4020

1. Turn right
2. Forward
3. Reverse
4. Turn left





decal119-4606

**119-4606**

1. Warning—read the *Operator's Manual*.
2. Cutting/dismemberment hazard; grinder—keep bystanders a safe distance away from the machine; do not operate the grinder head while transporting the machine.
3. Warning—stay away from moving parts; wait for all moving parts to stop.
4. Warning—do not operate this machine unless you are trained.
5. Explosion and electric shock hazard—do not dig in areas with buried utility lines; contact local power organizations before digging.
6. Tipping/crushing hazard—lower the cutter head when operating on slopes.
7. Explosion hazard, fueling—shut off the engine and extinguish all flames when fueling.
8. Warning—lower the grinder head, engage the parking brake (if applicable), shut off the engine, and remove the key before leaving the machine.

# Setup

## Loose Parts

Use the chart below to verify that all parts have been shipped.

Procedure	Description	Qty.	Use
<b>1</b>	Grinder control lever	1	Install the grinder control lever.
	Jam nut	1	
<b>2</b>	No parts required	–	Check the fluid levels.
<b>3</b>	No parts required	–	Charge the battery.

# 1

## Installing the Grinder Control Lever

Parts needed for this procedure:

1	Grinder control lever
1	Jam nut

### Procedure

1. Thread the jam nut onto the grinder control lever (Figure 3).

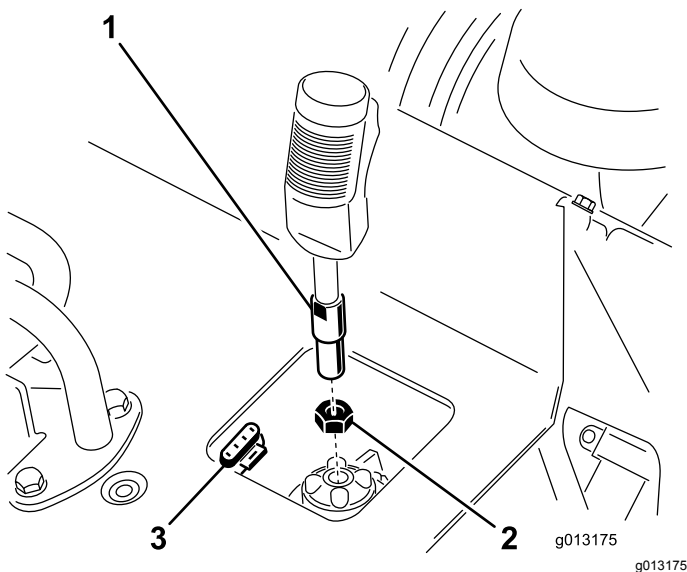

Figure 3

1. Grinder control lever
2. Jam nut
3. 4-pin connector

2. Thread the grinder control lever into the receptacle on the control panel (Figure 3).
3. With the trigger oriented forward, tighten the jam nut against the receptacle to secure the lever in place (Figure 3).
4. Connect the wire on the lever to the 4-pin connector under the control panel (Figure 3).

# 2

## Checking the Fluid Levels

No Parts Required

### Procedure

Before starting the engine for the first time, check the engine-oil and hydraulic-fluid levels. Refer to the following sections for more information:

- [Checking the Engine-Oil Level \(page 24\)](#)
- [Checking the Hydraulic-Fluid Level \(page 37\)](#)

# 3

## Charging the Battery

No Parts Required

### Procedure

Charge the battery; refer to [Charging the Battery \(page 29\)](#) for more information.

# Product Overview

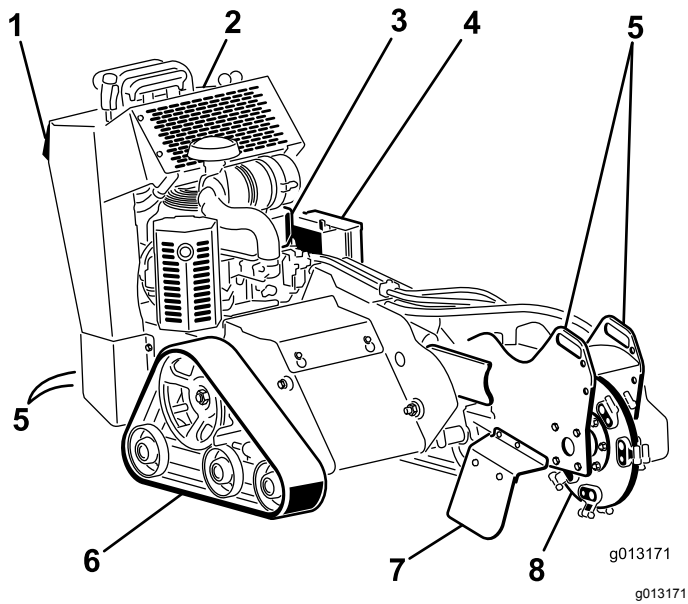

**Figure 4**

- |                         |            |                        |                |
|-------------------------|------------|------------------------|----------------|
| 1. Reverse safety plate | 3. Engine  | 5. Tie-down/lift point | 7. Chip shield |
| 2. Control panel        | 4. Battery | 6. Track               | 8. Grinder     |

# Control Panel

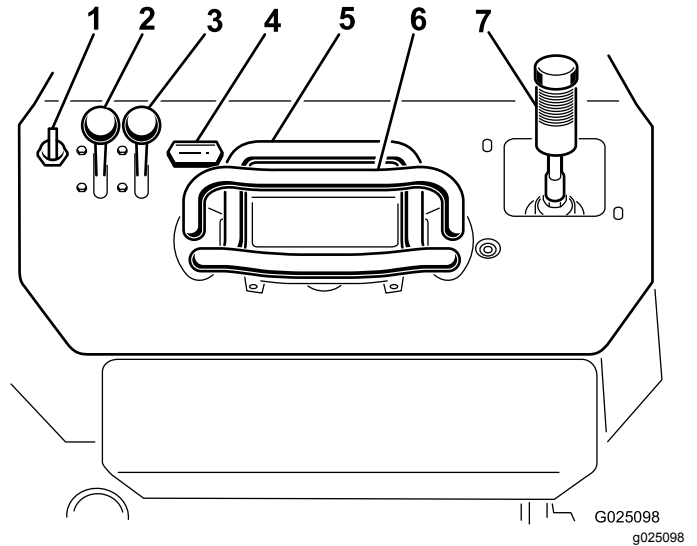

**Figure 5**

- |                   |   |
|-------------------|---|
| 1. Key switch     | 5. Traction control                     |
| 2. Throttle lever | 6. Reference bar                        |
| 3. Choke lever    | 7. Grinder control/hydraulic-lift lever |
| 4. Hour meter     |   |

## Controls

Become familiar with all the controls ([Figure 5](#)) before you start the engine and operate the machine.

### Key Switch

The key switch, used to start and shut off the engine, has 3 positions: OFF, RUN, and START. Refer to [Starting the Engine \(page 16\)](#).

### Throttle Lever

Move the control forward to increase the engine speed and rearward to decrease the engine speed.

### Choke Lever

Before starting a cold engine, move the choke lever forward. After the engine starts, regulate the choke to keep the engine running smoothly. As soon as possible, move the choke lever all the way rearward.

**Note:** A warm engine requires little or no choking.

### Hour Meter

When the engine is off, the hour meter displays the number of hours of operation that have been logged on the machine.

## Reference Bar

When driving the machine, use the reference bar as a handle and a leverage point for controlling the machine. To ensure smooth, controlled operation, do not take both hands off the reference bar while operating the machine.

## Traction Control

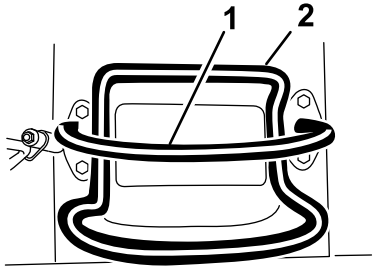

G008128

g008128

Figure 6

1. Reference bar
2. Traction control

- To move forward, move the traction control forward (Figure 7).

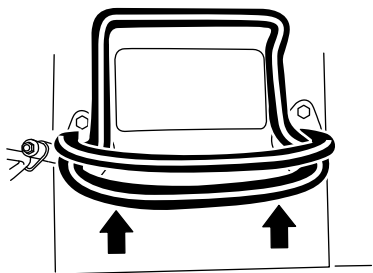

G008129

g008129

Figure 7

- To move rearward, move the traction control rearward (Figure 8).

**Important:** When reversing, look behind you for obstructions and keep your hands on the reference bar.

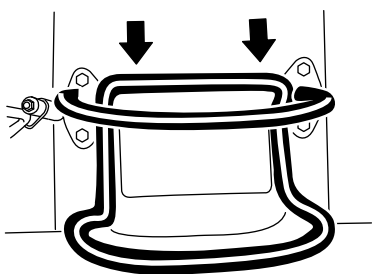

G008130

g008130

Figure 8

- To turn right, rotate the traction control clockwise (Figure 9).

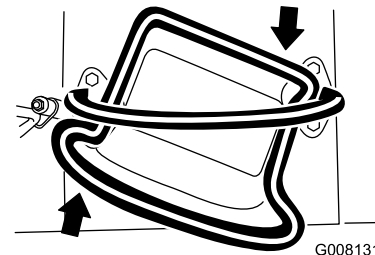

G008131

g008131

Figure 9

- To turn left, rotate the traction control counterclockwise (Figure 10).

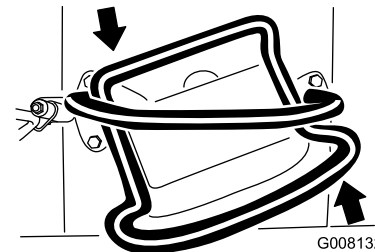

G008132

g008132

Figure 10

- To stop the machine, release the traction control (Figure 6).

**Note:** The farther you move the traction control in any direction, the faster the machine moves in that direction.

# Grinder Control/Hydraulic-Lift Lever

Operate the grinder using the grinder control lever as follows:

- To start the grinder (Figure 11), squeeze the trigger and then press the red button on the top of the lever. Once the grinder has started, you can release the red button.
- To stop the grinder (Figure 11), release the trigger for more than a half second.

**Note:** If you are operating the grinder and momentarily release the trigger (i.e., less than a half second), the grinder continues to operate.

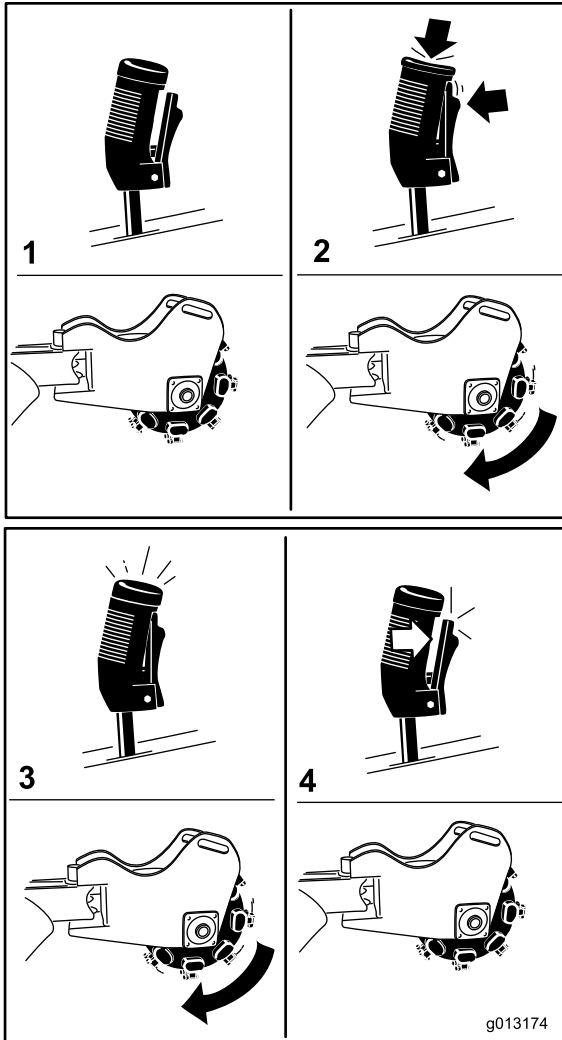

Figure 11

- |                      |                     |
|----------------------|---------------------|
| 1. Neutral           | 3. Run the grinder  |
| 2. Start the grinder | 4. Stop the grinder |

- To raise the grinder, pull the lever rearward (Figure 12).

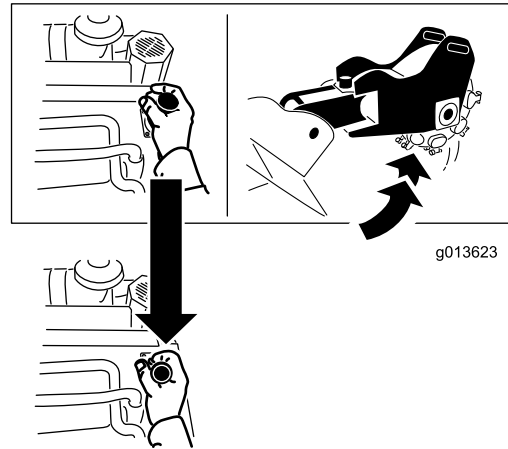

Figure 12

- To lower the grinder, push the lever forward (Figure 13).

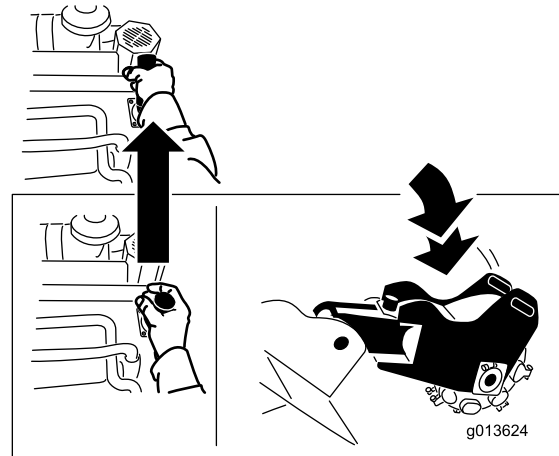
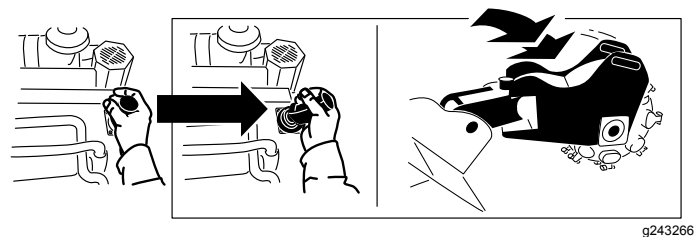
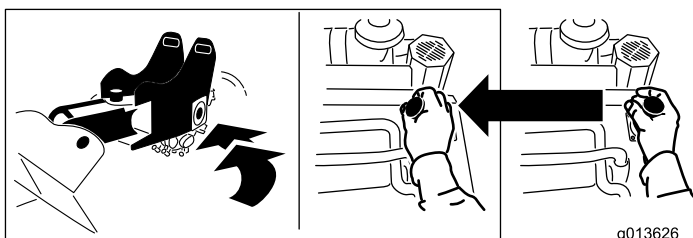

Figure 13

- To rotate the grinder to the right or left, move the lever in the desired direction (Figure 14).



g243266



g013626  
g013626

Figure 14

# Operation

**Note:** Determine the left and right sides of the machine from the normal operating position.

**Important:** Before operating, check the fuel and oil level, and remove debris from the machine. Also, ensure that the area is clear of people and debris. You should also know and have marked the locations of all utility lines.

Shut off the engine, remove the key, and wait for all moving parts to stop before leaving the operator position.

## Adding Fuel

### **⚠ DANGER**

In certain conditions, fuel is extremely flammable and highly explosive. A fire or explosion from fuel can burn you and others and can damage property.

- Fill the fuel tanks outdoors, in an open area, when the engine is cold. Wipe up any fuel that spills.
- Never fill the fuel tanks inside an enclosed trailer.
- Never smoke when handling fuel and stay away from an open flame or where fuel fumes may be ignited by a spark.
- Store fuel in an approved container and keep it out of the reach of children. Never buy more than a 30-day supply of fuel.
- Do not operate without entire exhaust system in place and in proper working condition.

## Specifications

**Note:** Specifications and design are subject to change without notice.

Width	84 cm (33 inches)
Length	198.5 cm (78 inches)
Height	113 cm (44.5 inches)
Weight	544 Kg (1,200 lb)

## Attachments/Accessories

A selection of Toro approved attachments and accessories is available for use with the machine to enhance and expand its capabilities. Contact your Authorized Service Dealer or authorized Toro distributor or go to [www.Toro.com](http://www.Toro.com) for a list of all approved attachments and accessories.

To ensure optimum performance and continued safety certification of the machine, use only genuine Toro replacement parts and accessories. Replacement parts and accessories made by other manufacturers could be dangerous, and such use could void the product warranty.

## **⚠ DANGER**

In certain conditions during fueling, static electricity can be released, causing a spark that can ignite the fuel vapors. A fire or explosion from fuel can burn you and others and can damage property.

- Always place fuel containers on the ground away from your vehicle before filling.
- Do not fill fuel containers inside a vehicle or on a truck or trailer bed, because interior carpets or plastic truck bed liners may insulate the container and slow the loss of any static charge.
- When practical, remove equipment from the truck or trailer and refuel the equipment with its wheels on the ground.
- If this is not possible, then refuel such equipment on a truck or trailer from a portable container rather than from a fuel-dispenser nozzle.
- If you must use a fuel-dispenser nozzle, keep the nozzle in contact with the rim of the fuel tank or container opening at all times until fueling is complete.

## **⚠ WARNING**

Fuel is harmful or fatal if swallowed. Long-term exposure to vapors can cause serious injury and illness.

- Avoid prolonged breathing of vapors.
- Keep your face away from the nozzle and fuel tank opening.
- Keep fuel away from your eyes and skin.

## **Recommended Fuel**

- For best results, use only clean, fresh (less than 30 days old), unleaded gasoline with an octane rating of 87 or higher ((R+M)/2 rating method).
- **Ethanol:** Gasoline with up to 10% ethanol (gasohol) or 15% MTBE (methyl tertiary butyl ether) by volume is acceptable. Ethanol and MTBE are not the same. Gasoline with 15% ethanol (E15) by volume is not approved for use. **Never use gasoline that contains more than 10% ethanol by volume**, such as E15 (contains 15% ethanol), E20 (contains 20% ethanol), or E85 (contains up to 85% ethanol). Using unapproved gasoline may cause performance problems and/or engine damage which may not be covered under warranty.
- **Do not** use gasoline containing methanol.
- **Do not** store fuel either in the fuel tank or fuel containers over the winter unless you use a fuel stabilizer.
- **Do not** add oil to gasoline.

## **Using Stabilizer/Conditioner**

Use fuel stabilizer/conditioner in the machine at all times to keep the fuel fresh longer when used as directed by the fuel-stabilizer manufacturer.

**Important:** Do not use fuel additives containing methanol or ethanol.

Add the amount of fuel stabilizer/conditioner to fresh fuel as directed by the fuel-stabilizer manufacturer.

## Filling the Fuel Tank

1. Park the machine on a level surface, engage the parking brake (if applicable), and lower the hydraulic lift.
2. Shut off the engine, remove the key, and allow the engine to cool.
3. Clean around the fuel-tank cap and remove it (Figure 15).

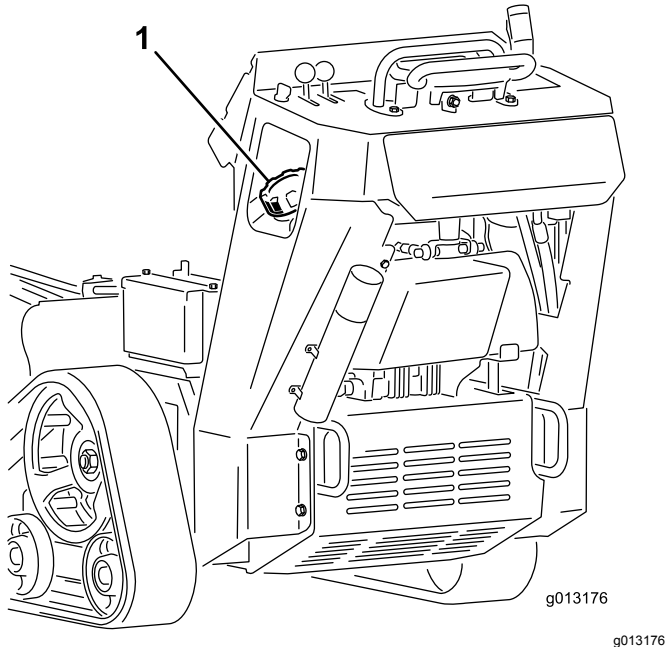

Figure 15

1. Fuel-tank cap

4. Fill the tank with fuel to about 6 to 13 mm (1/4 to 1/2 inch) below the bottom of the filler neck.

**Important:** This space in the tank allows fuel to expand. Do not fill the fuel tank completely full.

5. Install the fuel-tank cap securely.
6. Wipe up any spilled fuel.

## Performing Daily Maintenance

Before starting the machine each day, perform the Each Use/Daily procedures listed in [Maintenance \(page 20\)](#).

## Starting the Engine

1. Move the throttle lever midway between the SLOW and FAST positions (Figure 16).

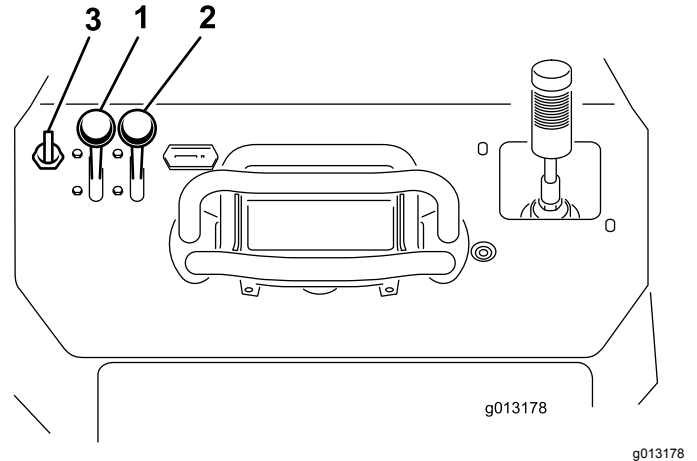

Figure 16

1. Throttle lever
2. Choke lever
3. Key

2. Move the choke lever to the ON position (Figure 16).

**Note:** A warm or hot engine may not require choking.

3. Turn the key to the ON position (Figure 16). When the engine starts, release the key.

**Important:** Do not engage the starter for more than 10 seconds at a time. If the engine fails to start, allow a 30-second cooldown period between attempts. Failure to follow these instructions can burn out the starter motor.

4. Gradually move the choke lever to the OFF position (Figure 16). If the engine stalls or hesitates, engage the choke again until the engine warms up.
5. Move the throttle lever to the desired setting (Figure 16).

**Important:** Running the engine at high speeds when the hydraulic system is cold (i.e., when the air temperature is at or below freezing) could damage the hydraulic system. When starting the engine in cold conditions, allow it to run in the middle throttle position for 2 to 5 minutes before moving the throttle to the FAST position.

**Note:** If the outdoor temperature is below freezing, store the machine in a garage to keep it warmer and aid in starting.



# Driving the Machine

Use the traction controls to move the machine. The farther you move the traction controls in any direction, the faster the machine moves in that direction. Release the traction controls to stop the machine.

## ⚠ CAUTION

**When reversing, you may back into stationary objects or over bystanders and cause serious personal injury or death.**

**Look behind you for obstructions or bystanders and keep your hands on the reference bar.**

The throttle control regulates the engine speed as measured in rpm (revolutions per minute). Place the throttle lever in the FAST position for best performance. You can, however, use the throttle position to operate at slower speeds.

# Shutting off the Engine

1. Park the machine on a level surface, engage the parking brake (if applicable), and lower the hydraulic lift.
2. Move the throttle lever to the SLOW position (Figure 16).
3. If the engine has been working hard or is hot, let it idle for a minute before turning the key switch to the OFF position.

**Note:** This helps to cool the engine before you shut it off. In an emergency, you can shut off the engine immediately.

4. Turn the key switch to the OFF position and remove the key.

## ⚠ CAUTION

**A child or untrained bystander could attempt to operate the machine and be injured.**

**Remove the key from the switch when leaving the machine, even if just for a few seconds.**

# Grinding a Stump

## ⚠ DANGER

**This machine is capable of amputating hands and feet.**

- Always wear substantial, slip-resistant footwear.
- Stay in the operating position while the machine is running, and keep away from moving parts.
- Keep all bystanders a safe distance away from the machine.
- Stop the machine immediately if any people or animals enter the work area.

## ⚠ WARNING

**Grinding a stump throws wood chips, soil, and other debris into the air, which could injure you or bystanders.**

- Always wear eye protection and long pants when using the grinder.
- Keep all bystanders a safe distance away from the grinder.

## ⚠ WARNING

**The grinder is very loud when cutting a stump and can damage your ears.**

**Always wear hearing protection when using the grinder.**

1. Start the engine, raise the grinder, set the throttle lever to the FAST position, and move the machine to the stump to be ground.
2. Use the grinder control lever and the traction control to position the grinder to the side of the front of the stump, about 2 cm (1 inch) below the surface (Figure 17).
3. Start the grinder and wait for it to get up to full speed.
4. Use the grinder control lever to swing the grinder slowly across the face of the stump, cutting away a swath of chips (Figure 17).

**Important:** The grinder automatically slows down the speed at which it swings into the stump to maintain the optimum flywheel speed and not bog down in the wood.

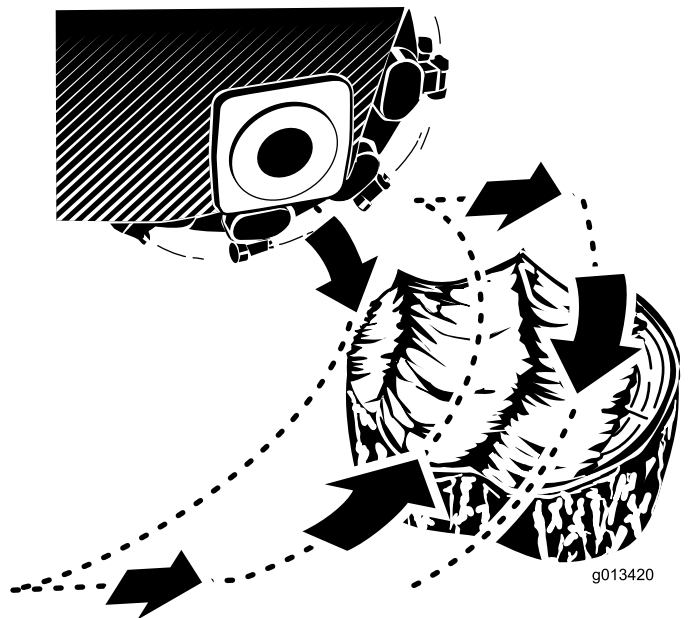

Figure 17

## Moving a Non-Functioning Machine

**Important:** Do not tow or pull the machine without first opening the tow valves, or you will damage the hydraulic system.

1. Engage the parking brake and lower the hydraulic lift.
2. Shut off the engine and remove the key.
3. Remove the bottom shield.
4. Using a wrench, turn the tow valves on the hydraulic pumps twice counter-clockwise (Figure 18).

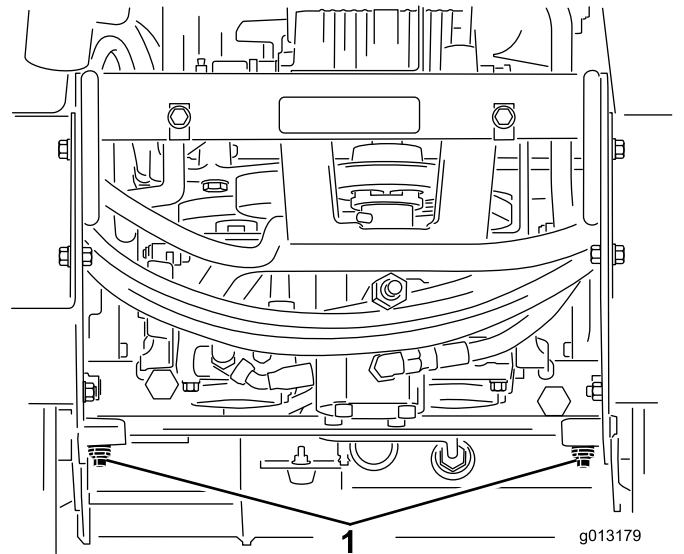

Figure 18

1. Tow valves

5. Install the bottom shield and tow the machine as required.
6. After repairing the machine, close the tow valves before operating it.

5. Move the machine forward a few centimeters (inches) and repeat step 4 (Figure 17).
6. Repeat steps 4 through 5 until you have ground off the entire face of the stump (Figure 17).
7. Back up the machine, position the grinder to the side of the front of the stump, and lower it to about 2 cm (1 inch) below the surface.
8. Repeat steps 4 through 7 until the stump is ground away.
9. If there are any large roots to be ground, position the grinder over each root and use the traction control and grinder control to move the grinder along the root, grinding it away.
10. Clean debris from the hydraulic lift, drives, mufflers, and engine after each use; refer to [Removing Debris from the Machine](#) (page 40).

## Securing the Machine for Transport

**Important:** Do not operate or drive the machine on roadways. Use care when loading or unloading the machine into a trailer or truck.

1. Park the machine on a level surface, engage the parking brake (if applicable), and lower the hydraulic lift.
2. Shut off the engine and remove the key.
3. Secure the machine to a trailer with chains or straps using the tie-down/lift loops at the front and rear of the machine (Figure 19 and Figure

20). Refer to your local ordinances for trailer and tie-down requirements.

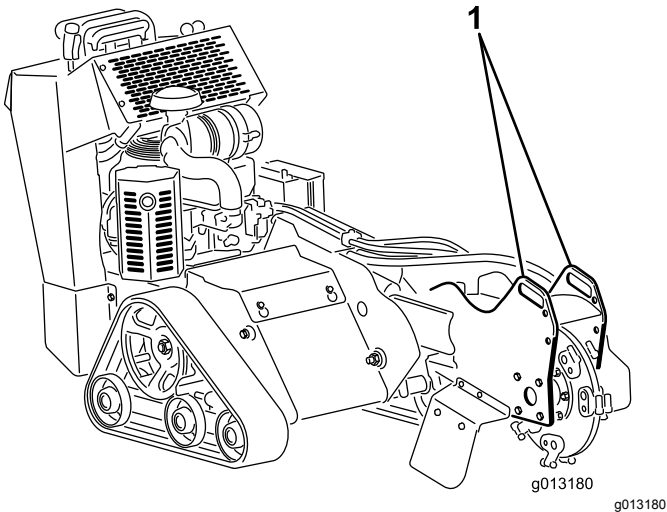

**Figure 19**

1. Front tie-down loop

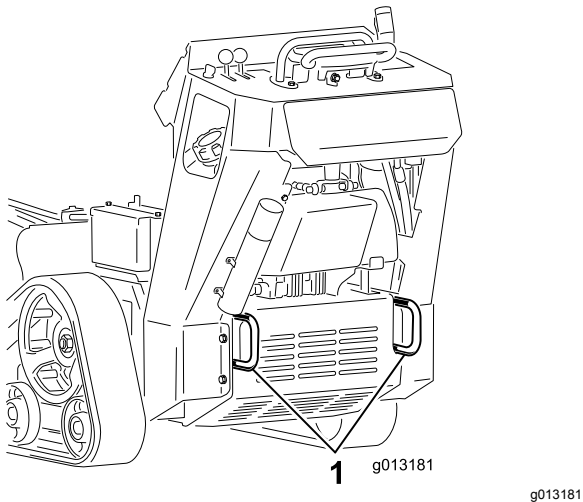
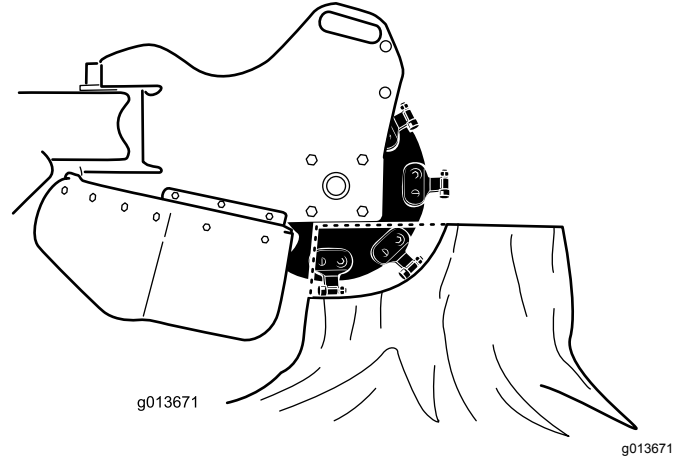

**Figure 20**

1. Rear tie-down loops

## Operating Tips

- Clean the area of trash, branches, and rocks before operating to prevent equipment damage.
- Always use full throttle (maximum engine speed) when grinding.
- Cut the edges of the stump for more efficient grinding. Once your cutting swath is close to 1/4 of the wheel diameter, lower the grinder and begin cutting on the edge again.



**Figure 21**

- Listen to the engine and watch the grinder wheel speed to maintain the speed of the wheel. Slow down the head sweep by feathering the joystick as cutting becomes difficult.
- As you grind from left to right, most of the debris goes to the left of the grinder wheel. When you grind from the right to left, the debris goes to the right.
- You may also grind a stump from the side to lessen turf damage.

## Lifting the Machine

You can lift the machine using the tie-down/lift loops as lift points (Figure 19 and Figure 20).

# Maintenance

**Note:** Determine the left and right sides of the machine from the normal operating position.

## Recommended Maintenance Schedule(s)

Maintenance Service Interval	Maintenance Procedure
After the first 8 hours	<ul style="list-style-type: none"><li>• Change the engine oil.</li></ul>
After the first 50 hours	<ul style="list-style-type: none"><li>• Check and adjust the track tension.</li></ul>
Before each use or daily	<ul style="list-style-type: none"><li>• Grease the machine. (Grease immediately after every washing.)</li><li>• Check the engine-oil level.</li><li>• Check the condition of and clean the tracks.</li><li>• Check the condition of the teeth; rotate or replace any that are worn or damaged and torque the nuts for all teeth.</li><li>• Check for loose fasteners.</li></ul>
After each use	<ul style="list-style-type: none"><li>• Remove debris from the machine.</li></ul>
Every 25 hours	<ul style="list-style-type: none"><li>• Check the battery electrolyte level.</li><li>• Check the hydraulic-fluid level.</li></ul>
Every 100 hours	<ul style="list-style-type: none"><li>• Change the engine oil.</li><li>• Replace or clean and gap the spark plug(s).</li><li>• Check and adjust the track tension.</li><li>• Check the hydraulic lines for leaks, loose fittings, kinked lines, loose mounting supports, wear, weather, and chemical deterioration and repair if necessary.</li></ul>
Every 200 hours	<ul style="list-style-type: none"><li>• Change the engine-oil filter.</li><li>• Replace the fuel filter.</li></ul>
Every 250 hours	<ul style="list-style-type: none"><li>• Replace the primary air filter and check the condition of the safety filter (more often in dirty or dusty conditions).</li><li>• Check and grease the road wheels.</li></ul>
Every 400 hours	<ul style="list-style-type: none"><li>• Change the hydraulic fluid.</li></ul>
Every 500 hours	<ul style="list-style-type: none"><li>• Replace the safety air filter (more often in dirty or dusty conditions).</li></ul>
Every 1,500 hours	<ul style="list-style-type: none"><li>• Replace all moving hydraulic hoses.</li></ul>
Yearly or before storage	<ul style="list-style-type: none"><li>• Check and adjust the track tension.</li><li>• Touch up chipped paint.</li></ul>

**Important:** Refer to your engine owner's manual for additional maintenance procedures.

### **⚠ CAUTION**

If you leave the key in the key switch, someone could accidentally start the engine and seriously injure you or other bystanders.

Remove the key from the key switch and disconnect the wires from the spark plugs before you do any maintenance. Set the wires aside so that they do not accidentally contact the spark plugs.

# Pre-Maintenance Procedures

**Important:** The fasteners on the covers of this machine are designed to remain on the cover after removal. Loosen all fasteners on each cover a few turns so that the cover is loose but still attached, then go back and loosen them until the cover comes free. This prevents you from accidentally stripping the bolts free of the retainers.

## Removing the Cover Plate

1. Park the machine on a level surface, engage the parking brake (if applicable), and lower the hydraulic lift.
2. Shut off the engine and remove the key.

### ⚠ WARNING

There is a belt under the cover that is moving when the machine is running and can catch fingers, hands, loose hair, and clothing, causing serious injury, amputation, or death.

Always shut off the engine and wait for all moving parts to stop before removing the cover.

3. Loosen the bolt at the rear of the cover plate.
4. Loosen the 3 bolts securing the cover plate to the frame sequentially until the cover is loose (Figure 22).

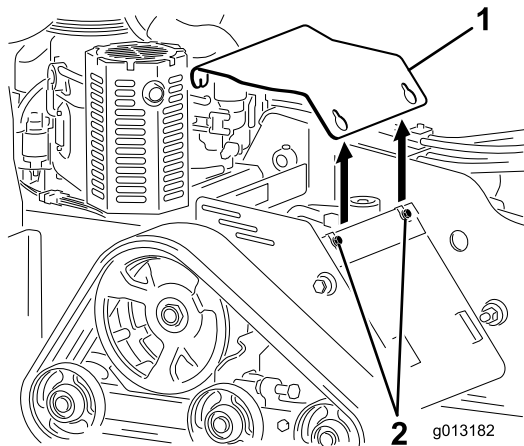

Figure 22

1. Cover plate
2. Bolts

5. Pull up the rear of the cover plate until it clears the engine and then pull it off over the bolt heads and off the machine.

6. To install the cover plate before operating the machine, slide the plate into place and secure it with the 3 bolts you loosened previously (Figure 22).

## Removing the Bottom Shield

1. Park the machine on a level surface, engage the parking brake (if applicable), and lower the hydraulic lift.
2. Shut off the engine and remove the key.
3. Loosen the 2 bolts securing the bottom shield sequentially until the shield is free (Figure 23).

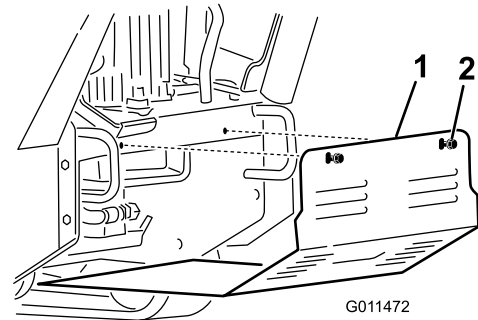

Figure 23

1. Bottom shield
2. Bolts

4. Pull the shield back and out of the machine.
5. To install the shield before operating the machine, slide the bottom shield into the machine so that it rests on all 4 tabs and secure it with the 2 bolts you loosened previously (Figure 23).

**Note:** You may need to lift up on the bottom shield to ensure that it rests on the front tabs.

# Lubrication

## Greasing the Machine

**Service Interval:** Before each use or daily (Grease immediately after every washing.)

**Grease Type:** General-purpose grease

1. Park the machine on a level surface and lower the hydraulic lift.
2. Shut off the engine and remove the key.
3. Clean the grease fittings with a rag.
4. Connect a grease gun to each fitting ([Figure 24](#) and [Figure 25](#)).
5. Pump grease into the fittings until grease begins to ooze out of the bearings (approximately 3 pumps).
6. Wipe up any excess grease.

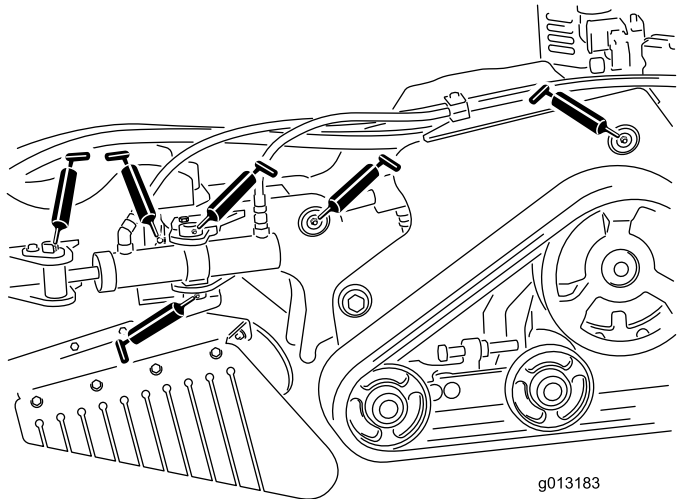

**Figure 24**

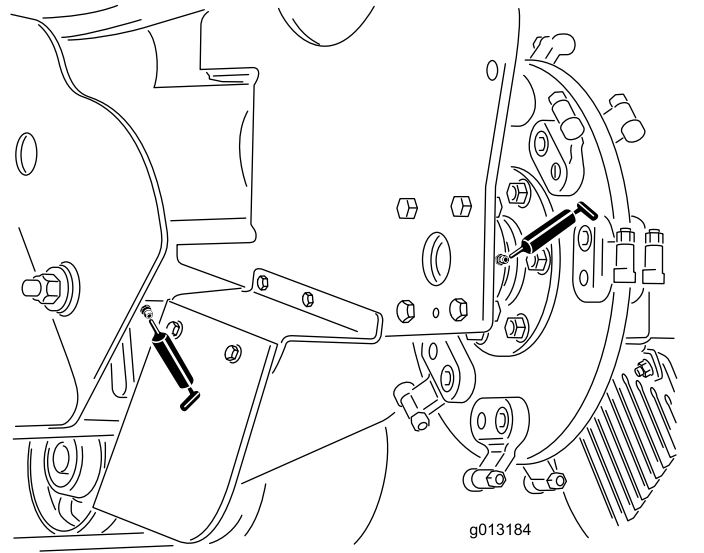

**Figure 25**

# Engine Maintenance

## Servicing the Air Cleaner

**Service Interval:** Every 250 hours—Replace the primary air filter and check the condition of the safety filter (more often in dirty or dusty conditions).

Every 500 hours—Replace the safety air filter (more often in dirty or dusty conditions).

### Removing the Filters

1. Park the machine on a level surface, engage the parking brake (if applicable), and lower the hydraulic lift.
2. Shut off the engine and remove the key.
3. Release the latches on the air cleaner and pull the air-cleaner cover off the air-cleaner body (Figure 26).

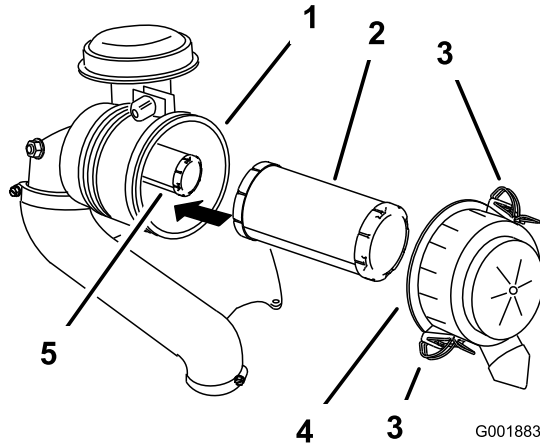

Figure 26

- |                     |                      |
|---------------------|----------------------|
| 1. Air-cleaner body | 4. Air-cleaner cover |
| 2. Primary filter   | 5. Safety filter     |
| 3. Latch            |                      |

4. Clean the inside of the air-cleaner cover with compressed air.
5. Gently slide the primary filter out of the air-cleaner body (Figure 26).

**Note:** Avoid knocking the filter into the side of the body.

6. Remove the safety filter only if you intend to replace it.

**Important:** Do not attempt to clean the safety filter. If the safety filter is dirty, then the primary filter is damaged. Replace both filters.

## Servicing the Primary Filter

Inspect the primary filter for damage by looking into the filter while shining a bright light on the outside of the filter.

**Note:** Holes in the filter appear as bright spots. If the filter is dirty, bent, or damaged, replace it. Do not clean the primary filter.

## Servicing the Safety Filter

Replace the safety filter; never clean it.

**Important:** Do not attempt to clean the safety filter. If the safety filter is dirty, then the primary filter is damaged. Replace both filters.

## Installing the Filters

**Important:** To prevent engine damage, always operate the engine with both air filters and the cover installed.

1. If installing new filters, check each filter for shipping damage.
2. If you are replacing the safety filter, carefully slide it into the filter body (Figure 26).
3. Carefully slide the primary filter over the safety filter (Figure 26).

**Note:** Do not use a damaged filter.

**Note:** If you are replacing the safety filter, carefully slide it into the filter body (Figure 26).

**Note:** Carefully slide the primary filter over the safety filter (Figure 26).

**Note:** Ensure that the primary filter is fully seated by pushing on its outer rim while installing it.

**Important:** Do not press on the soft inside area of the filter.

4. Install the air-cleaner cover with the side indicated as **up** facing upward and secure the latches (Figure 26).

# Servicing the Engine Oil

**Service Interval:** After the first 8 hours—Change the engine oil.

Before each use or daily—Check the engine-oil level.

Every 100 hours—Change the engine oil.

Every 200 hours—Change the engine-oil filter.

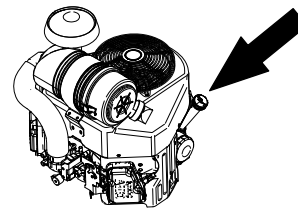

g242254

## Engine-Oil Specifications

**Note:** Change the oil more frequently when the operating conditions are extremely dusty or sandy.

**Oil Type:** Detergent oil (API service SF, SG, SH, or SJ)

**Crankcase Capacity:** 2.1 L (71 fl oz) with the filter removed; 1.8 L (61 fl oz) without the filter removed

**Viscosity:** Refer to the table below.

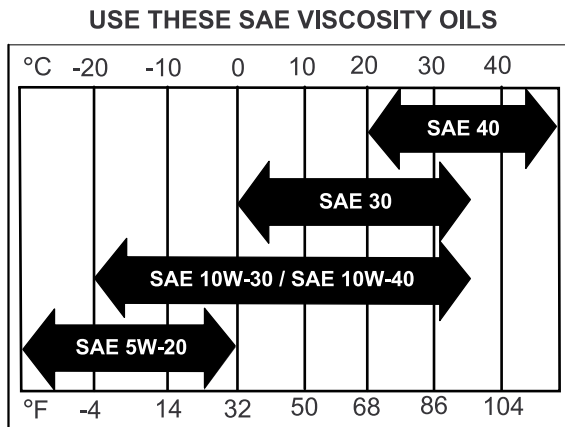

G004216

g004216

Figure 27

## Checking the Engine-Oil Level

1. Park the machine on a level surface, engage the parking brake (if applicable), and lower the hydraulic lift.
2. Shut off the engine and remove the key.

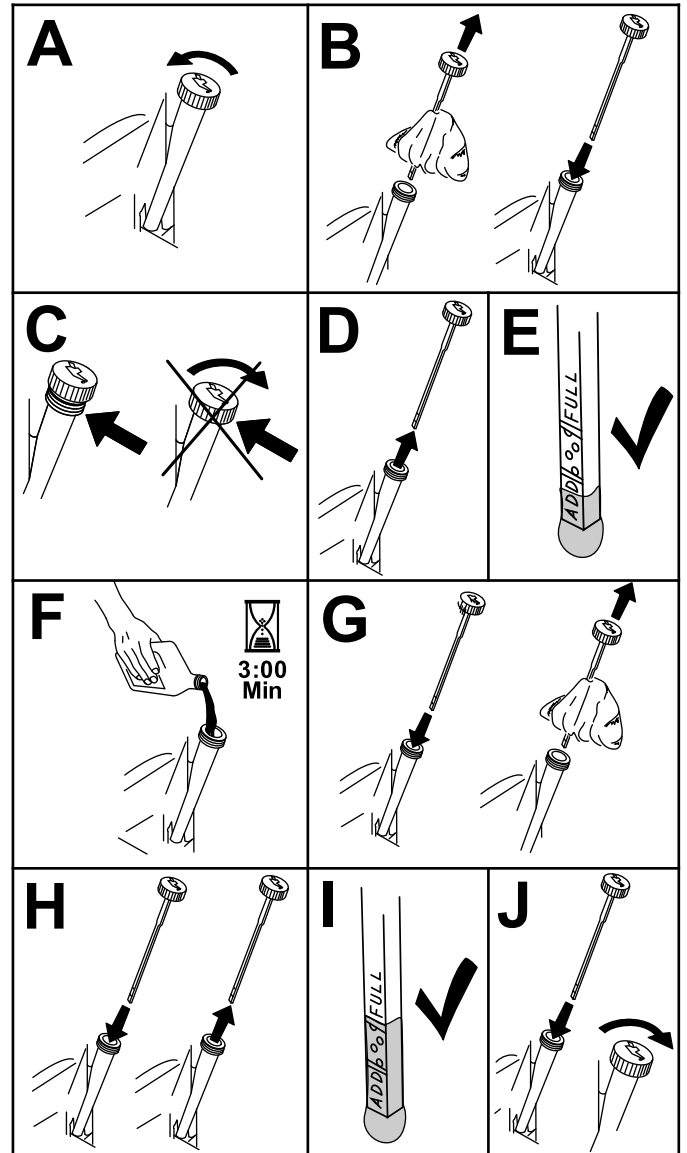

g194611

Figure 28



# Changing the Engine Oil

**Note:** Dispose of the used oil at a recycling center.

1. Start the engine and let it run for 5 minutes.
 

**Note:** This warms the oil so that it drains better.
2. Park the machine on a level surface, engage the parking brake (if applicable), and lower the hydraulic lift.
3. Shut off the engine and remove the key.
4. Change the oil as shown in (Figure 29).

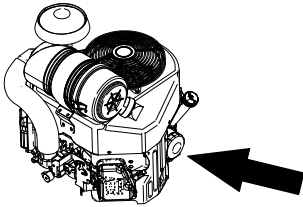

g242255

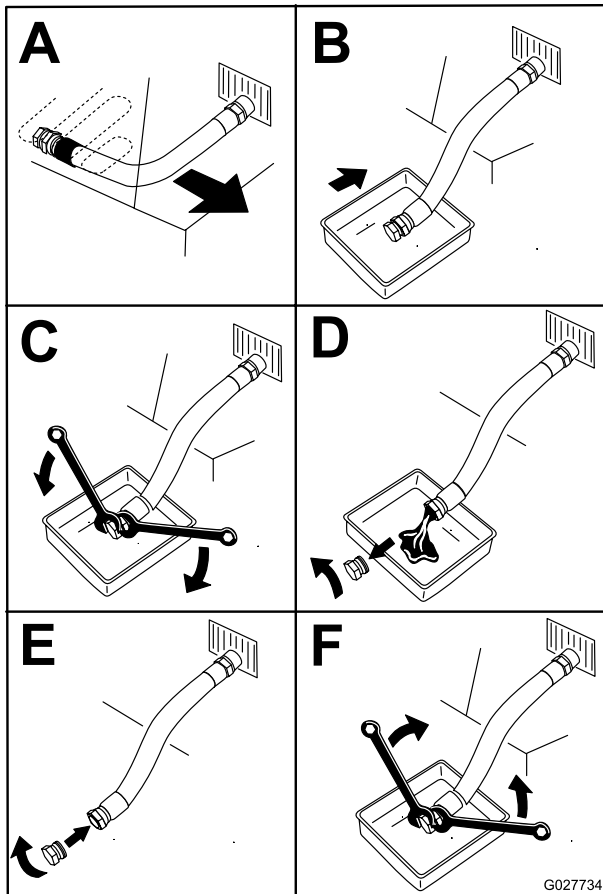

G027734

g027734

Figure 29

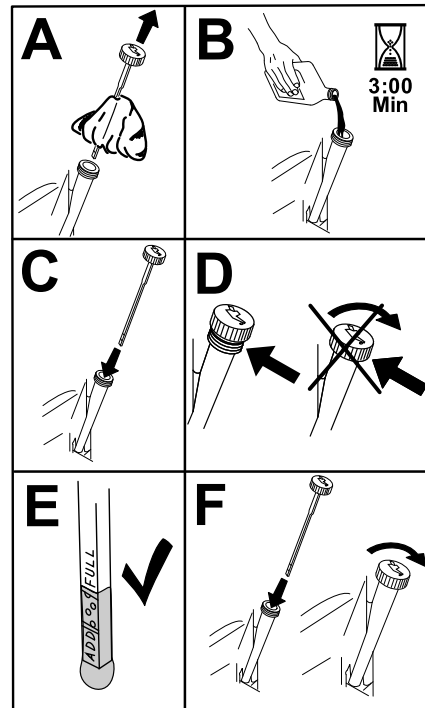

Figure 30

g194610

6. Start the engine and drive to a flat area.
7. Check the oil level again.

5. Slowly pour approximately 80% of the specified oil into the filler tube and slowly add the additional oil to bring it to the **Full** mark (Figure 30).

## Changing the Engine-Oil Filter

1. Drain the oil from the engine; refer to [Changing the Engine Oil \(page 25\)](#).
2. Change the engine-oil filter ([Figure 31](#)).

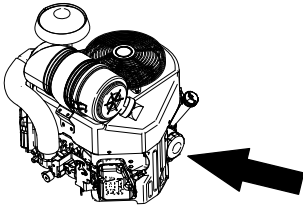

g242255

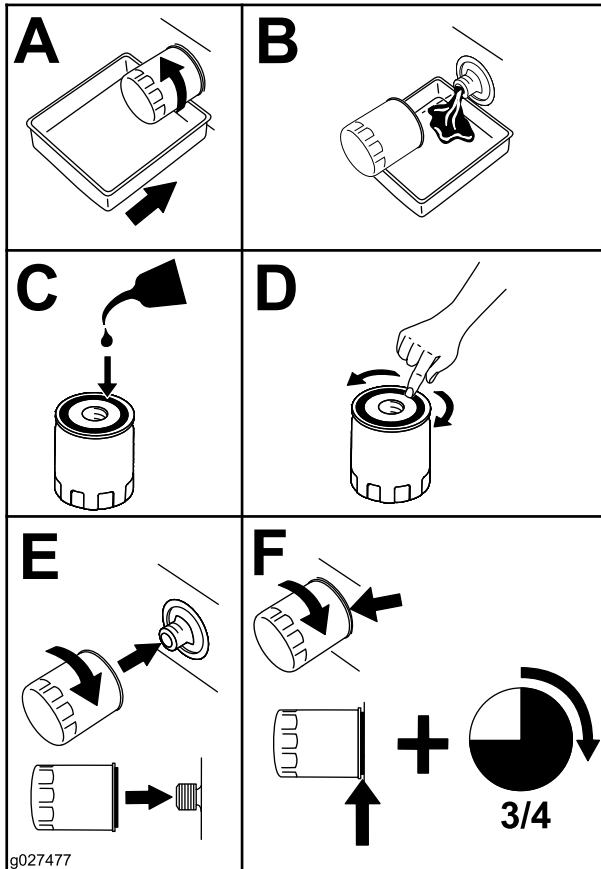

g027477

g027477

Figure 31

## Servicing the Spark Plug(s)

**Service Interval:** Every 100 hours

Make sure that the air gap between the center and side electrodes is correct before installing the spark plug(s). Use a spark plug wrench for removing and installing the spark plug(s) and a gapping tool/feeler gauge to check and adjust the air gap. Install a new spark plug(s) if necessary.

**Type of Spark Plug:** NGK® BPR4ES or equivalent

**Air Gap:** 0.75 mm (0.03 inch)

### Removing the Spark Plug(s)

1. Park the machine on a level surface, engage the parking brake (if applicable), and lower the hydraulic lift.
2. Shut off the engine and remove the key.
3. Locate and remove the spark plug(s) as shown in [Figure 32](#).

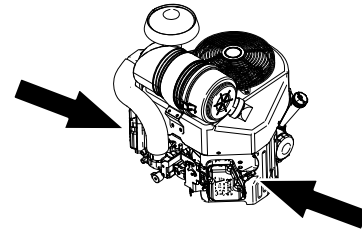

g249482

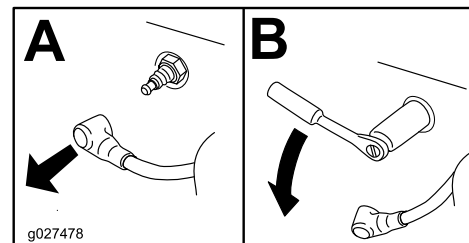

g027478

g027478

Figure 32

**Note:** Ensure that the oil-filter gasket touches the engine, and then turn the oil filter an extra 3/4 turn.

3. Fill the crankcase with the proper type of new oil; refer to [Engine-Oil Specifications \(page 24\)](#).

## Checking the Spark Plug(s)

**Important:** Do not clean the spark plug(s). Always replace the spark plug(s) when it has: a black coating, worn electrodes, an oily film, or cracks.

If you see light brown or gray on the insulator, the engine is operating properly. A black coating on the insulator usually means the air cleaner is dirty.

Set the gap to 0.75 mm (0.03 inch).

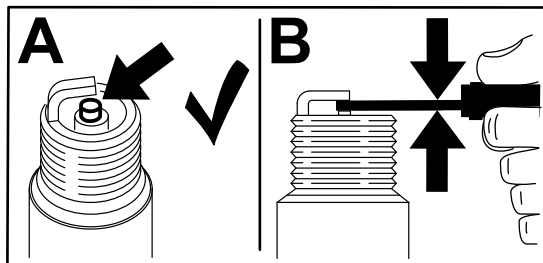

Figure 33

g206628

## Installing the Spark Plug(s)

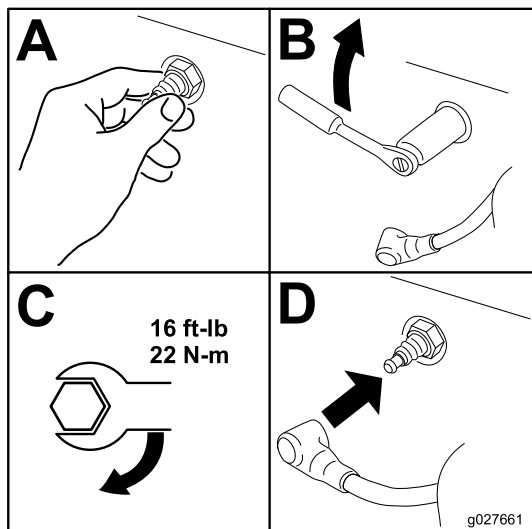

Figure 34

g027661

g027661

# Fuel System Maintenance

## Draining the Fuel Tank

### **⚠ DANGER**

In certain conditions, fuel is extremely flammable and highly explosive. A fire or explosion from fuel can burn you and others and can damage property.

Refer to [Fuel Safety \(page 4\)](#) for a complete list of fuel related precautions.

1. Park the machine on a level surface, engage the parking brake, and lower the hydraulic lift.
2. Shut off the engine and remove the key.
3. Turn the fuel-shutoff valve to the closed position ([Figure 35](#)).

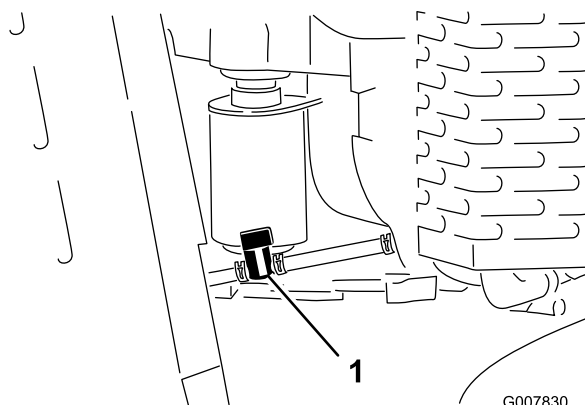

Figure 35

G007830

g007830

1. Fuel-shutoff valve
  4. Squeeze the ends of the hose clamp on the engine side of the valve together and slide it up the fuel line away from the valve ([Figure 35](#)).
  5. Pull the fuel line off the valve ([Figure 35](#)).
  6. Open the fuel-shutoff valve and allow the fuel to drain into a fuel can or drain pan.
- Note:** If desired, you can replace the fuel filter at this time; refer to [Replacing the Fuel Filter \(page 28\)](#).
7. Install the fuel line onto the fuel-shutoff valve. Slide the hose clamp close to the valve to secure the fuel line.
  8. Wipe up any spilled fuel.

# Replacing the Fuel Filter

**Service Interval:** Every 200 hours

1. Park the machine on a level surface, engage the parking brake, and lower the hydraulic lift.
2. Shut off the engine and remove the key.

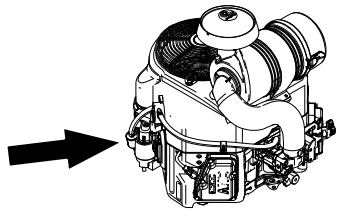

g242257

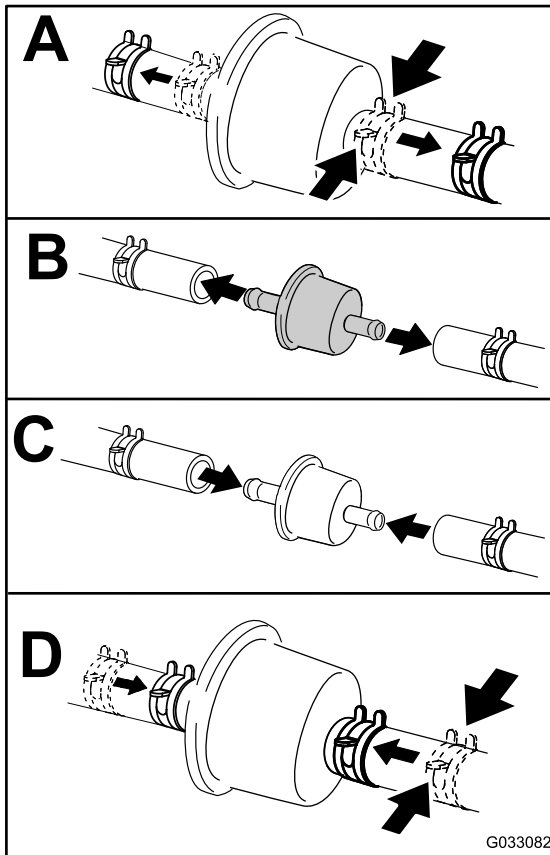

Figure 36

g033082

# Electrical System Maintenance

## Servicing the Battery

**Service Interval:** Every 25 hours—Check the battery electrolyte level.

Always keep the battery clean and fully charged. Use a paper towel to clean the battery case. If the battery terminals are corroded, clean them with a solution of 4 parts water and 1 part baking soda. Apply a light coating of grease to the battery terminals to reduce corrosion.

Voltage: 12 V with 300 A (cold cranking) at -18°C (0°F).

### ⚠ WARNING

Incorrect battery cable routing could damage the machine and cables, causing sparks. Sparks can cause the battery gasses to explode, resulting in personal injury.

- Always disconnect the negative (black) cable before disconnecting the positive (red) cable.
- Always connect the positive (red) cable before connecting the negative (black) cable.

### ⚠ WARNING

Battery terminals or metal tools could short against metal components, causing sparks. Sparks can cause the battery gasses to explode, resulting in personal injury.

- When removing or installing the battery, do not allow the battery terminals to touch any metal parts of the traction unit.
- Do not allow metal tools to short between the battery terminals and metal parts of the traction unit.

## Removing the Battery

1. Park the machine on a level surface, engage the parking brake, and lower the hydraulic lift.
2. Shut off the engine and remove the key.
3. Lift the black rubber cover on the negative cable. Disconnect the negative battery cable from the negative (-) battery terminal (Figure 37).

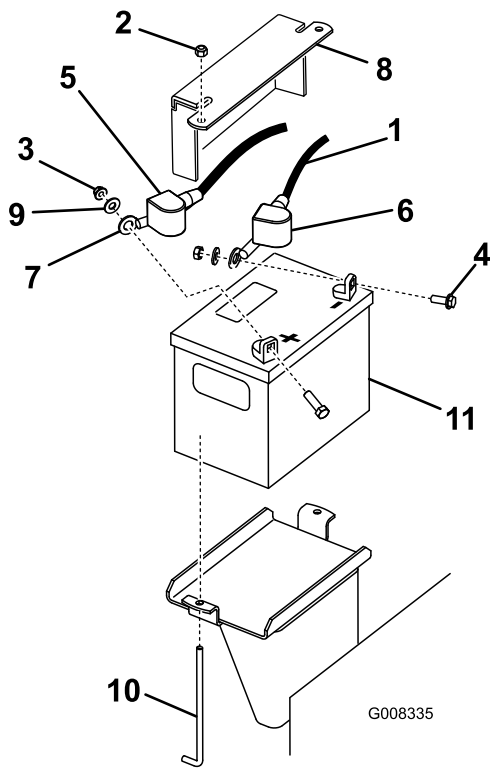

Figure 37

- |                         |                            |
|-------------------------|----------------------------|
| 1. Negative cable       | 7. Positive cable          |
| 2. Nut (1/4 inch)       | 8. Battery hold down plate |
| 3. Nut (5/16 inch)      | 9. Washer                  |
| 4. Bolt                 | 10. J-bolt                 |
| 5. Rubber cover (red)   | 11. Battery                |
| 6. Rubber cover (black) |                            |

- Slide the red terminal boot off the positive (red) battery terminal, then remove the positive (red) battery cable (Figure 37).
- Remove the hold down plate, J-bolts, and locknuts securing the battery (Figure 37) and remove the battery.

## Charging the Battery

### ⚠ WARNING

Charging the battery produces gasses that can explode.

Never smoke near the battery and keep sparks and flames away from battery.

**Important:** Always keep the battery fully charged (1.265 specific gravity). This is especially important to prevent battery damage when the temperature is below 0°C (32°F).

- Remove the battery from the machine; refer to [Removing the Battery \(page 28\)](#).

- Charge the battery at a rate of 3 to 4 A for 4 to 8 hours (Figure 38). Do not overcharge the battery.

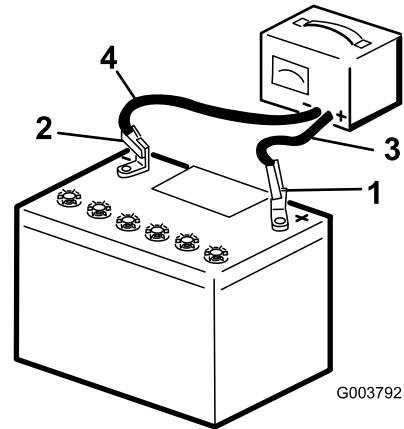

Figure 38

- |                          |                           |
|--------------------------|---------------------------|
| 1. Positive battery post | 3. Red (+) charger lead   |
| 2. Negative battery post | 4. Black (-) charger lead |

- When the battery is fully charged, unplug the charger from the electrical outlet, then disconnect the charger leads from the battery posts (Figure 38).

## Checking the Battery Electrolyte Level

### ⚠ DANGER

Battery electrolyte contains sulfuric acid which is fatal if consumed and causes severe burns.

- Do not drink electrolyte and avoid contact with skin, eyes or clothing. Wear safety glasses to shield your eyes and rubber gloves to protect your hands.
- Fill the battery where clean water is always available for flushing the skin.

- Park the machine on a level surface, engage the parking brake, and lower the hydraulic lift.
- Shut off the engine and remove the key.
- Look at the side of the battery. The electrolyte must be up to the **upper** line (Figure 39). Do not allow the electrolyte to fall below the Lower line (Figure 39).

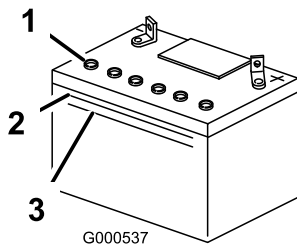

**Figure 39**

g000537

1. Vent caps
2. Upper line
3. Lower line

- 
4. If the electrolyte is low, add the required amount of distilled water; refer to [Adding Water to the Battery \(page 30\)](#).

## Adding Water to the Battery

The best time to add distilled water to the battery is just before you operate the machine. This lets the water mix thoroughly with the electrolyte solution.

1. Park the machine on a level surface, engage the parking brake, and lower the hydraulic lift.
2. Shut off the engine and remove the key.
3. Remove the battery from the machine; refer to [Removing the Battery \(page 28\)](#).

**Important:** Never fill the battery with distilled water while the battery is installed in the machine. Electrolyte could spill on other parts and cause corrosion.

4. Clean the top of the battery with a paper towel.
5. Remove the vent caps from the battery ([Figure 39](#)).
6. Slowly pour distilled water into each battery cell until the electrolyte level is up to the Upper line ([Figure 39](#)) on the battery case.

**Important:** Do not overfill the battery; electrolyte (sulfuric acid) can cause severe corrosion and damage to the chassis.

7. Wait 5 to 10 minutes after filling the battery cells. Add distilled water, if necessary, until the electrolyte level is up to the Upper line ([Figure 39](#)) on the battery case.
8. Install the battery vent caps.

## Cleaning the Battery

**Note:** Keep the terminals and the entire battery case clean, because a dirty battery discharges slowly.

1. Park the machine on a level surface, engage the parking brake, and lower the hydraulic lift.
2. Shut off the engine and remove the key.
3. Remove the battery from the machine; [Removing the Battery \(page 28\)](#).
4. Wash the entire case with a solution of baking soda and water.
5. Rinse the battery with clear water.
6. Coat the battery posts and cable connectors with Grafo 112X (skin-over) grease (Toro Part No. 505-47) or petroleum jelly to prevent corrosion.
7. Install the battery; refer to [Installing the Battery \(page 30\)](#).

## Installing the Battery

1. Using the fasteners previously removed, install the positive (red) battery cable to the positive (+) battery terminal ([Figure 37](#)).
2. Slide the red terminal boot onto the positive battery post.
3. Using the fasteners previously removed, install the negative (black) battery cable to the negative (-) battery terminal ([Figure 37](#)).
4. Secure the battery using the bar and wing nuts ([Figure 37](#)).

**Important:** Ensure that the battery cables do not contact any sharp edges or each other.

# Replacing the Fuses

There are 4 fuses in the electrical system. They are under the control panel on the left side (Figure 40).

Start circuit	30 A
Charge circuit	25 A
Cooler fan circuit	20 A
Headlight (optional)	15 A

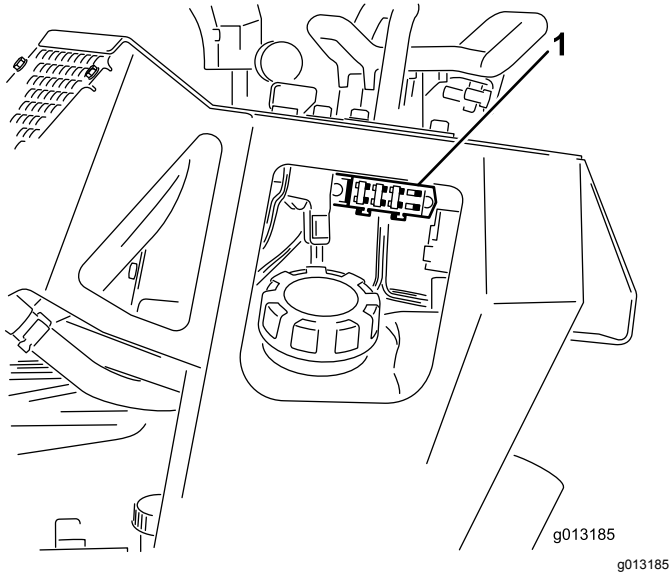

Figure 40

1. Fuse block

# Drive System Maintenance

## Servicing the Tracks

### Cleaning the Tracks

**Service Interval:** Before each use or daily

Check the tracks for excessive wear and clean them periodically. If the tracks are worn, replace them.

1. Park the machine on a level surface, engage the parking brake, and lower the hydraulic lift.
2. Shut off the engine and remove the key.
3. Using a water hose or pressure washer, remove dirt from each track system.

**Important:** Ensure that you use high-pressure water to wash only the track area. Do not use a high-pressure washer to clean the rest of the machine. High-pressure washing can damage the electrical system and hydraulic valves or deplete grease.

**Important:** Ensure that you fully clean the road wheels and the drive wheel (Figure 41). The road wheels should rotate freely when clean.

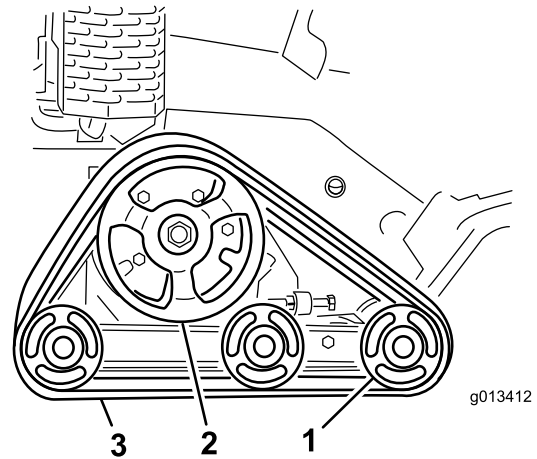

Figure 41

1. Road wheels
2. Drive wheel
3. Track

# Checking and Adjusting the Track Tension

**Service Interval:** After the first 50 hours  
Every 100 hours

To check the tension of each track, place 20.4 kg (45 lb) on the track midway between the front road wheel and the drive wheel. The track should flex no more than 0.6 to 1 cm (1/4 to 3/8 inch). If it does, adjust the track tension using the following procedure:

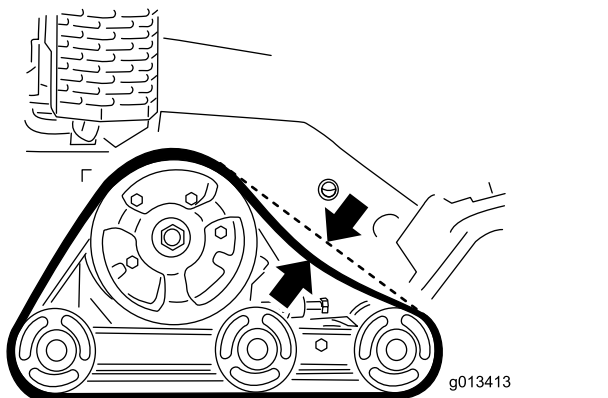

Figure 42

1. Park the machine on a level surface, engage the parking brake, and lower the hydraulic lift.
2. Shut off the engine and remove the key.
3. Loosen the jam nut on the track tensioning bolt and the clamp bolts on the tension arm (Figure 43).

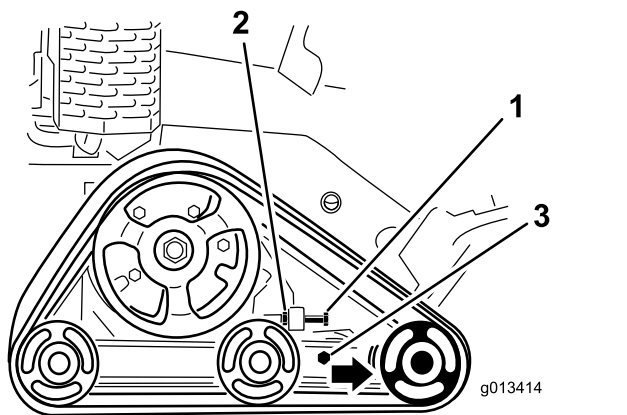

Figure 43

1. Tensioning bolt
2. Jam nut
3. Clamp bolts

4. Torque the tensioning bolt to 32.5 to 40 N·m (24 to 30 ft·lb) to tighten the track (Figure 43).
5. Ensure that the track deflects less than 0.6 to 1 cm (1/4 to 3/8 inch) when 20.6 kg (45 lb) of force

is applied to the track span. Adjust the torque on the tensioning bolt as needed.

6. Tighten the jam nut.
7. Tighten the clamp bolts and torque to 102 N·m (75 ft·lb).

## Replacing the Tracks

When the tracks are badly worn, replace them.

1. Park the machine on a level surface, engage the parking brake, and lower the hydraulic lift.
2. Shut off the engine and remove the key.
3. Lift and support the side of the unit to be worked on so that the track is 7.6 to 10 cm (3 to 4 inches) off the ground.
4. Back out the tensioning bolt and jam nut (Figure 43).
5. Loosen the clamp bolts (Figure 43).
6. Push the front road wheel rearward as far as it can go (Figure 44).

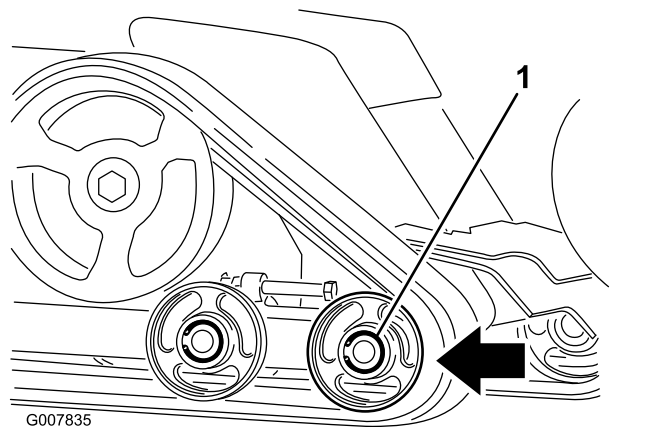

Figure 44

1. Front road wheel
7. Begin removing the track at the top of the front road wheel, peeling it off the wheel while rotating the track forward.

**Note:** You may need to remove the front, outside road wheel. To remove it, remove the snap ring and cap from the center of the road wheel (Figure 45). Next remove the bolt and gasket from the center of the wheel and pull the wheel off the machine.



# Checking and Greasing the Road Wheels

**Service Interval:** Every 250 hours

1. Park the machine on a level surface, engage the parking brake, and lower the hydraulic lift.
2. Shut off the engine and remove the key.
3. Remove the tracks; refer to [Replacing the Tracks \(page 32\)](#).
4. Remove the snap ring and cap from a road wheel ([Figure 46](#)).

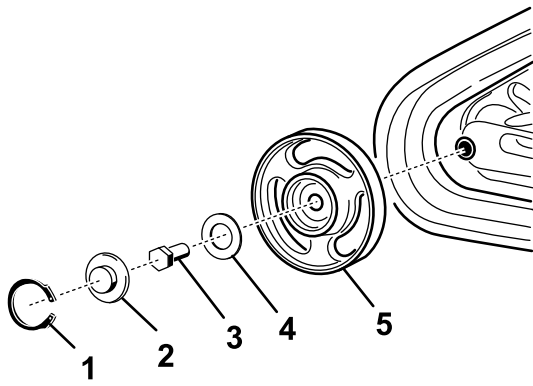
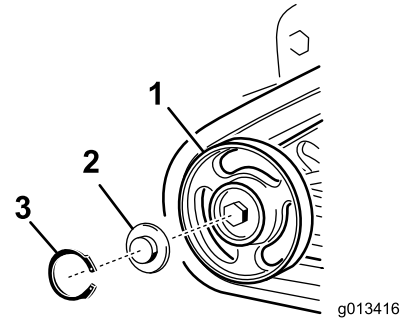

**Figure 45**

g242269

- |              |                        |
|--------------|------------------------|
| 1. Snap ring | 4. Gasket              |
| 2. Cap       | 5. Wheel with bearings |
| 3. Bolt      |                        |

8. When the track is off the road wheel, remove it from the machine ([Figure 44](#)).
9. Beginning at the drive wheel, coil the new track around the wheel, ensuring that the lugs on the track fit between the spacers on the wheel ([Figure 44](#)).
10. Push the track under and between the rear and center road wheels ([Figure 44](#)).
11. Starting at the bottom of the front road wheel, install the track around the wheel by rotating the track rearward while pushing the lugs into the wheel.
12. If you removed the front, outside road wheel, install it at this time using the bolt and gasket removed previously. Torque the bolt to 102 N·m (75 ft-lb) and then clean, grease, and install the cap and snap ring as instructed in the [Checking and Greasing the Road Wheels \(page 33\)](#).
13. Install the tensioning bolt and jam nut.
14. Torque the tensioning bolt to 32.5 to 40 N·m (24 to 30 ft-lb) to tighten the track.
15. Ensure that the track deflects less than 0.6 to 1 cm (1/4 to 3/8 inch) when 20.6 kg (45 lb) of force is applied to the track span. Adjust the torque on the tensioning bolt as needed.
16. Tighten the jam nut.
17. Tighten the clamp bolts and torque to 102 N·m (75 ft-lb).
18. Lower the machine to the ground.
19. Repeat the procedure to replace the other track.



**Figure 46**

g013416

g013416

- |                   |              |
|-------------------|--------------|
| 1. Road wheel     | 3. Snap ring |
| 2. Road wheel cap |              |

5. Check the grease under the cap and around the gasket ([Figure 46](#)). If it is dirty, gritty, or depleted, clean out all of the grease, replace the gasket, and add new grease.
6. Ensure that the road wheel turns smoothly on the bearing. If it is frozen, contact your Authorized Service Dealer to replace the road wheel.
7. Place the greased road wheel cap over the bolt head ([Figure 46](#)).
8. Secure the road wheel cap with the snap ring ([Figure 46](#)).
9. Repeat steps 4 through 8 for all 12 road wheels.
10. Install the tracks; refer to [Replacing the Tracks \(page 32\)](#).

# Belt Maintenance

## Replacing the Pump-Drive Belt

If the pump drive belt begins to squeal or is cracked, worn, or frayed, replace it. Contact your Authorized Service Dealer for a replacement belt.

1. Park the machine on a level surface, engage the parking brake, and lower the hydraulic lift.
2. Shut off the engine and remove the key.
3. Raise the back of the machine and support it on jack stands.
4. Remove the bottom shield; refer to [Removing the Bottom Shield \(page 21\)](#).
5. Loosen the 2 pump bolts ([Figure 47](#)).

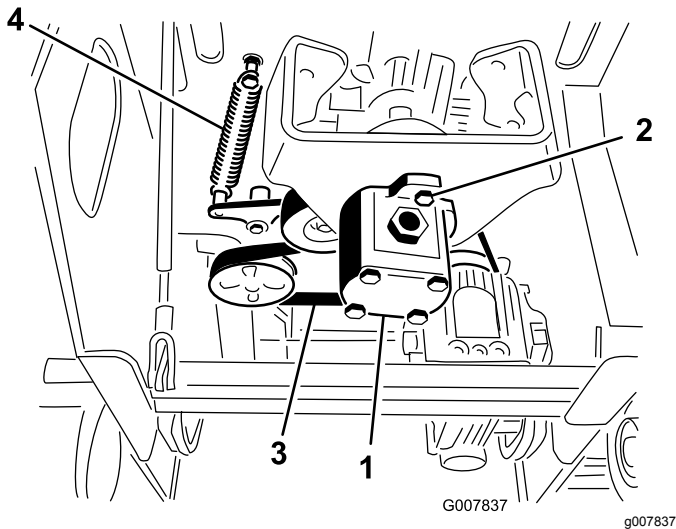

**Figure 47**

- |               |                        |
|---------------|------------------------|
| 1. Pump       | 3. Belt                |
| 2. Pump bolts | 4. Idler-pulley spring |

6. Twist the pump counterclockwise and allow it to drop down away from the pulley ([Figure 47](#)).

**Note:** Ensure that the spider coupler drops down with the pump.

7. Using a spring puller (contact your Authorized Service Dealer) or stiff metal hook, pull the end of the idler pulley spring off the spring bolt to release tension on the belt ([Figure 47](#)).
8. Remove the belt.
9. Route a new belt around the pulleys.
10. Install the idler-pulley spring on the bolt.
11. Ensure that the spider coupler is in place on the pump and then insert it into the pulley, twisting it clockwise to seat it on the pump bolts.

12. Torque the pump bolts to 68 N·m (50 ft-lb).
13. Install the bottom shield.

# Controls System Maintenance

## Adjusting the Traction-Control Alignment

The factory adjusts the traction controls before shipping the machine. However, after many hours of use, you may need to adjust the traction-control alignment, the neutral position of the traction control, and the tracking of the traction control in the full forward position.

**Important:** To adjust the controls properly, complete each procedure in the order listed.

## Adjusting the Traction-Control Reverse Position

If the traction control bar does not rest flush and square with the reference bar when in the full reverse position, immediately complete the following procedure:

1. Park the machine on a level surface, engage the parking brake (if applicable), and lower the hydraulic lift.
2. Shut off the engine and remove the key.
3. Pull back the traction control so that the front of the control contacts the reference bar (Figure 48).

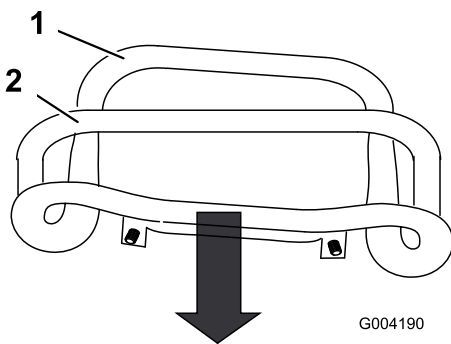

Figure 48

1. Front of the control (out of alignment)
2. Reference bar

4. If the front of the traction control does not rest square and flush with the reference bar, loosen the nut and bolt in the stem of the traction control (Figure 49).

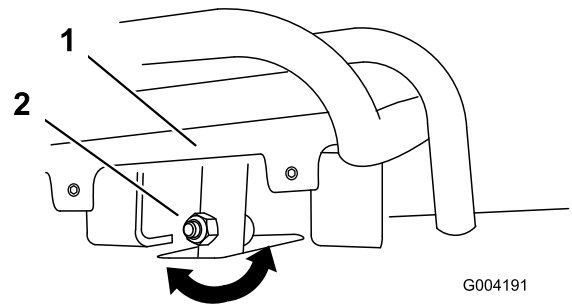

Figure 49

1. Traction control
2. Stem, bolt, and nut

5. Adjust the traction control so that it rests flush against the reference bar when it is pulled straight back (Figure 49 and Figure 50).

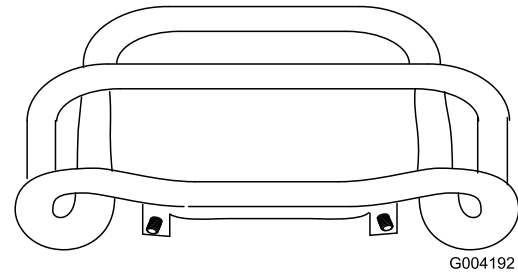
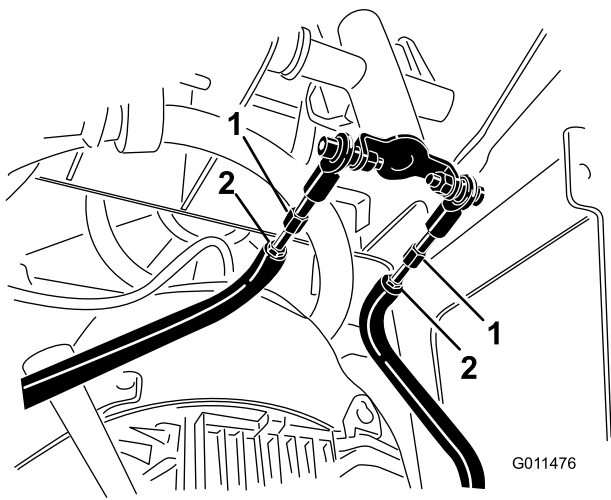

Figure 50

6. Tighten the flange nut and bolt in the traction control stem.
7. Start the engine.
8. Drive the machine in reverse with the traction control tight to the reference bar. If the machine does not back up straight, complete the following procedure:
  - A. Shut off the engine
  - B. Lift and support the machine so that both tracks are off the ground and are free to run.
  - C. Loosen the flange nut and bolt in the stem of the traction control (Figure 49).
  - D. Loosen the jam nuts on the traction rods, under the control panel (Figure 51).



**Figure 51**

1. Traction rod                      2. Jam nut

- E. Start the machine and set the throttle to about the 1/3 open position.

**⚠ WARNING**

**When the machine is running, you could be caught and injured in moving parts or burned on hot surfaces.**

**Stay away from pinch points, moving parts, and hot surfaces when adjusting the running machine.**

- F. Have a helper hold the traction control tight to the reference bar in reverse.  
 G. Adjust the length of the traction rods until both tracks are running at the same speed.

**Note:** You can also adjust the maximum reverse speed of the tracks at this time.

- H. Tighten the jam nuts.  
 I. Adjust the traction control so that it rests flush against the reference bar when it is pulled straight back (Figure 49 and Figure 50).  
 J. Tighten the flange nut and bolt in the traction control stem.  
 K. Shut off the engine and lower the machine to the ground.  
 L. Drive the machine in full reverse, checking to see if the machine tracks straight. If it does not, note the direction the machine veers. Repeat the adjustment so that the machine tracks straight in reverse.

## Adjusting the Traction-Control Neutral Position

If the machine creeps forward or backward when the traction control is in neutral and the machine is warm, you may need to adjust the return-to-neutral mechanism on the pumps; contact your Authorized Service Dealer.

## Adjusting the Traction-Control Forward Position

If the machine does not drive straight when you hold the traction control forward against the reference bar, complete the following procedure:

1. Drive the machine with the traction control against the reference bar, noting which direction the machine veers.
2. Release the traction control.
3. If the machine veers to the **left**, loosen the **right** jam nut and adjust the tracking set screw on the front of the traction control (Figure 52).
4. If the machine veers to the **right**, loosen the **left** jam nut and adjust the tracking set screw on the front of the traction control (Figure 52).

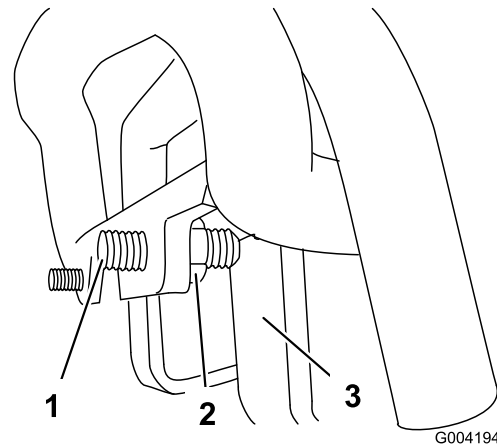

**Figure 52**

1. Set screw                              3. Stop  
 2. Jam nut

5. Repeat the procedure until the machine drives straight in the full forward position.

**Important:** Ensure that the set screws touch the stops in the full forward position to avoid overstroking the hydraulic pumps.

# Hydraulic System Maintenance

## ⚠ WARNING

Hydraulic fluid escaping under pressure can penetrate skin and cause injury. Fluid injected into the skin must be surgically removed within a few hours by a doctor familiar with this form of injury; otherwise, gangrene may result.

- Keep your body and hands away from pinhole leaks or nozzles that eject high-pressure hydraulic fluid.
- Use cardboard or paper to find hydraulic leaks; never use your hands.

## Hydraulic Fluid Specifications

Every 1,500 hours/Every 2 years (whichever comes first)—Replace all moving hydraulic hoses.

**Hydraulic Tank Capacity:** 23 L (6 US gallons)

Use only 1 of the following fluids in the hydraulic system:

- **Toro Premium Transmission/Hydraulic Tractor Fluid** (refer to your Authorized Toro Dealer for more information)
- **Toro Premium All Season Hydraulic Fluid** (refer to your Authorized Toro Dealer for more information)
- If either of the above Toro fluids are not available, you may use another **Universal Tractor Hydraulic Fluid (UTHF)**, but they must be only **conventional, petroleum-based** products. The specifications must fall within the listed range for all the following material properties and the fluid should meet the listed industry standards. Check with your hydraulic fluid supplier to determine if the fluid meets these specifications.

**Note:** Toro will not assume responsibility for damage caused by improper substitutions, so use only products from reputable manufacturers who will stand behind their recommendations.

Material Properties	
Viscosity, ASTM D445	cSt at 40°C: 55 to 62
	cSt at 100°C: 9.1 to 9.8
Viscosity index, ASTM D2270	140 to 152

Pour Point, ASTM D97	-37 to -43°C (-35 to -46°F)
<b>Industry Standards</b>	
API GL-4, AGCO Powerfluid 821 XL, Ford New Holland FNHA-2-C-201.00, Kubota UDT, John Deere J20C, Vickers 35VQ25 and Volvo WB-101/BM	

**Note:** Many hydraulic fluids are almost colorless, making it difficult to spot leaks. A red dye additive for the hydraulic system fluid is available in 20 ml (0.67 fl oz) bottles. One bottle is sufficient for 15 to 22 L (4 to 6 US gallons) of hydraulic fluid. Order Part No. 44-2500 from your Authorized Toro Dealer.

## Checking the Hydraulic-Fluid Level

**Service Interval:** Every 25 hours

Refer to [Hydraulic Fluid Specifications \(page 37\)](#).

1. Park the machine on a level surface, engage the parking brake (if applicable), and lower the hydraulic lift.
2. Shut off the engine and remove the key.
3. Look into the glass bubble on the right side of the machine. If you cannot see hydraulic fluid in the bubble, continue this procedure to add fluid.

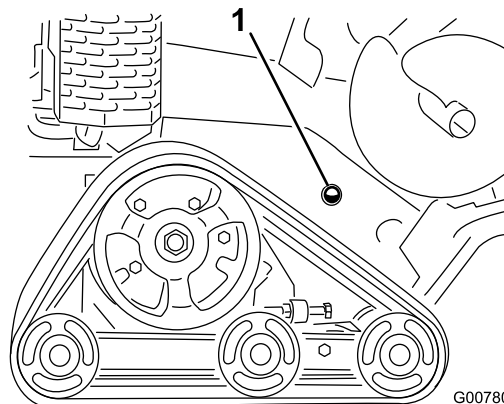

**Figure 53**

1. Hydraulic-fluid check bubble
4. Remove the cover plate; refer to [Removing the Cover Plate \(page 21\)](#).
5. Clean the area around the filler neck of the hydraulic tank and remove the cap and filter from the filler neck using a socket ([Figure 54](#)).

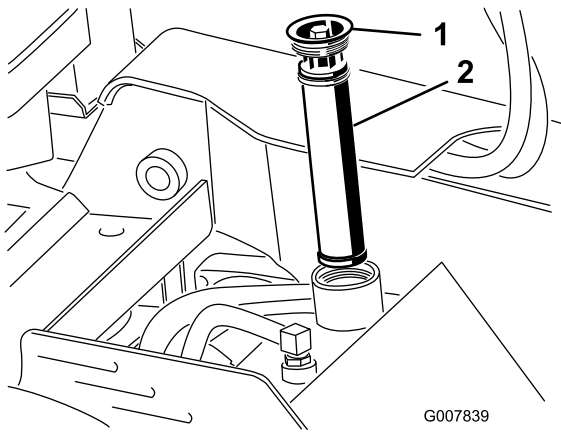

**Figure 54**

1. Filler-neck cap
2. Hydraulic-fluid filter

6. If the level is low, add fluid until it is visible in the glass bubble.
7. Install the cap and filter on the filler neck and torque bolt on top to 13 to 15.5 N·m (110 to 140 in-lb).
8. Install the cover plate; refer to [Removing the Cover Plate \(page 21\)](#).

## Changing the Hydraulic Fluid

**Service Interval:** Every 400 hours/Yearly (whichever comes first)

1. Park the machine on a level surface, engage the parking brake (if applicable), and lower the hydraulic lift.
2. Shut off the engine and remove the key.
3. Allow the machine to cool completely.
4. Remove the top cover.
5. Remove the hydraulic-tank filler cap and filter ([Figure 54](#)).
6. Place a drain pan capable of holding 37.8 L (10 US gallons) under the hydraulic tank.
7. Pinch the hose clamp and slide the clamp and hose off the fitting on the hydraulic tank, allowing the hydraulic fluid to drain from the hose and tank into the pan.

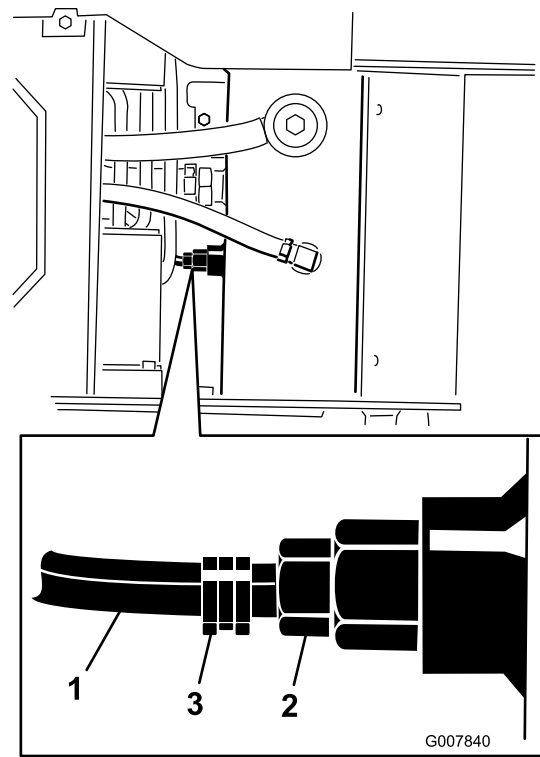

**Figure 55**

1. Hose
2. Hydraulic-tank fitting
3. Hose clamp

8. When finished, install the hose onto the fitting and secure it with the hose clamp.

**Note:** Dispose of the used oil at a certified recycling center.

9. Fill the hydraulic tank with hydraulic fluid; refer to [Hydraulic Fluid Specifications \(page 37\)](#).
10. Install the hydraulic filter and filler cap ([Figure 54](#)) and torque the bolt on top to 13 to 15.5 N·m (110 to 140 in-lb).
11. Start the engine and let it run for a few minutes.
12. Shut off the engine.
13. Check the hydraulic-fluid level and top it off if necessary; refer to [Checking the Hydraulic-Fluid Level \(page 37\)](#).
14. Clean up any spilled fluid.
15. Install the top cover.

# Grinder Maintenance

## Replacing the Teeth

**Service Interval:** Before each use or daily—Check the condition of the teeth; rotate or replace any that are worn or damaged and torque the nuts for all teeth.

Due to the high amount of wear placed on the teeth, you need to rotate and replace them periodically (Figure 56).

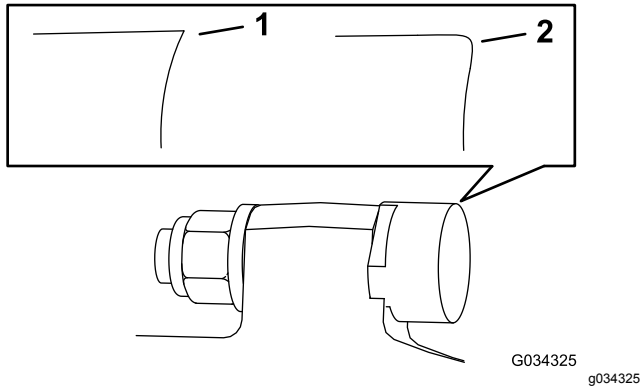

**Figure 56**

1. Sharp tooth
2. Worn tooth

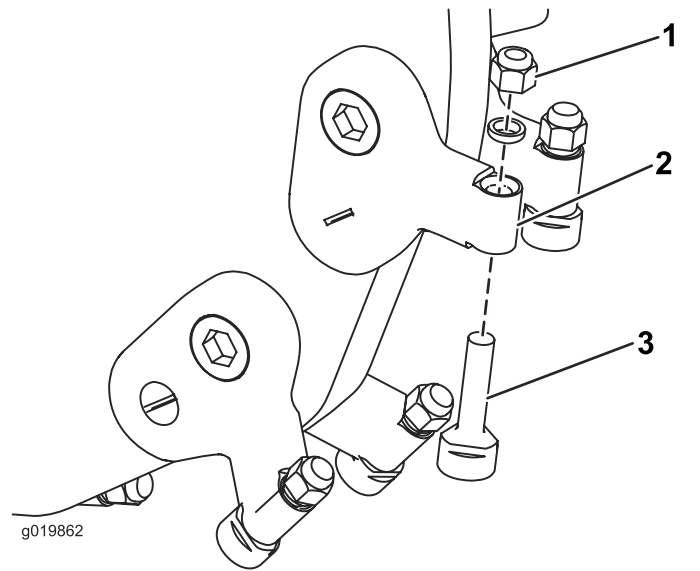

**Figure 57**

1. Nut
2. Tooth holder
3. Tooth

Each tooth is indexed with 3 positions so you can rotate it twice, exposing a new sharp edge before replacing the tooth. To rotate a tooth, loosen the nut securing the tooth (Figure 57). Push the tooth forward and rotate it one third of a turn, bringing an unused edge to the outside. Torque the nut securing the tooth to 37 to 45 N·m (27 to 33 ft-lb).

To replace a tooth, remove the nut securing the tooth to remove it, then install a new tooth, spacer, and nut in the same position (Figure 57). Torque the nut securing the tooth to 37 to 45 N·m (27 to 33 ft-lb).

# Cleaning

## Removing Debris from the Machine

**Service Interval:** After each use

**Important:** Operating the engine with blocked screens, dirty or plugged cooling fins, and/or cooling shrouds removed will result in engine damage from overheating.

1. Park the machine on a level surface, engage the parking brake (if applicable), and lower the hydraulic lift.
2. Shut off the engine, remove the key, and wait for the engine to cool.
3. Wipe away debris from the air cleaner.
4. Clean any debris buildup on the engine and muffler with a brush or blower.

**Important:** It is preferable to blow dirt out, rather than washing it out. If you use water, keep it away from electrical items and hydraulic valves. Do not use a high-pressure washer. High-pressure washing can damage the electrical system and hydraulic valves or deplete grease.

5. Clean debris from the oil cooler.

# Storage

1. Park the machine on a level surface, engage the parking brake, and lower the hydraulic lift.
2. Shut off the engine, remove the key, and wait for the engine to cool.
3. Remove dirt and grime from the external parts of the entire machine, especially the engine. Clean dirt and chaff from the outside of the engine cylinder head fins and blower housing.

**Important:** You can wash the machine with mild detergent and water. Do not pressure wash the machine. Avoid excessive use of water, especially near the control panel, engine, hydraulic pumps, and motors.

4. Service the air cleaner; refer to [Servicing the Air Cleaner \(page 23\)](#).
5. Grease the machine; refer to [Greasing the Machine \(page 22\)](#).
6. Change the crankcase oil; refer to [Changing the Engine Oil \(page 25\)](#).
7. Remove the spark plug and check the condition of it; refer to [Servicing the Spark Plug\(s\) \(page 26\)](#).
8. For storage over 30 days, prepare the machine as follows:
  - A. Add a petroleum-based stabilizer/conditioner to fuel in the tank. Follow the mixing instructions from the stabilizer manufacturer. Do not use an alcohol-based stabilizer (ethanol or methanol).

**Note:** A fuel stabilizer/conditioner is most effective when it is mixed with fresh fuel and is used at all times.
  - B. Run the engine to distribute conditioned fuel through the fuel system for 5 minutes.
  - C. Shut off the engine, allow it to cool, and drain the fuel tank using a pump type syphon.
  - D. Start the engine and run it until it shuts off.
  - E. Engage the choke.
  - F. Start and run the engine until it does not start again.
  - G. Dispose of fuel properly. Recycle as per local codes.

**Important:** Do not store fuel containing stabilizer/conditioner longer than the duration recommended by the fuel-stabilizer manufacturer.



9. With the spark plug removed from the engine, pour 2 tablespoons of engine oil into the spark-plug hole.
10. Place a rag over the spark-plug hole to catch any oil spray, then use the starter or recoil handle to crank the engine and distribute the oil inside the cylinder.
11. Install the spark plug, but do not install the wire on the spark plug.
12. Charge the battery; refer to [Charging the Battery \(page 29\)](#).
13. Check and adjust the track tension; refer to [Checking and Adjusting the Track Tension \(page 32\)](#).
14. Check and tighten all fasteners. Repair or replace any part that is damaged.
15. Paint all scratched or bare metal surfaces with paint available from your Authorized Service Dealer.
16. Store the machine in a clean, dry garage or storage area. Remove the key from the ignition switch and keep it in a memorable place.
17. Cover the machine to protect it and keep it clean.

# Troubleshooting

Problem	Possible Cause	Corrective Action
The starter does not crank.	<ol style="list-style-type: none"> <li>1. The battery is discharged.</li> <li>2. The electrical connections are corroded or loose.</li> <li>3. The relay or switch is damaged.</li> </ol>	<ol style="list-style-type: none"> <li>1. Charge the battery or replace it.</li> <li>2. Check the electrical connections for good contact.</li> <li>3. Contact your Authorized Service Dealer.</li> </ol>
The engine does not start, starts hard, or fails to keep running.	<ol style="list-style-type: none"> <li>1. The fuel tank is empty.</li> <li>2. The fuel-shutoff valve is closed.</li> <li>3. The controls are not in neutral.</li> <li>4. The choke is not on.</li> <li>5. The air cleaner is dirty.</li> <li>6. The spark-plug wire is loose or disconnected.</li> <li>7. The spark plug is pitted, fouled, or the gap is incorrect.</li> <li>8. Dirt, water, or stale fuel is in fuel system.</li> </ol>	<ol style="list-style-type: none"> <li>1. Fill the tank with fresh fuel.</li> <li>2. Open the fuel-shutoff valve.</li> <li>3. Move the controls to neutral.</li> <li>4. Move the choke lever fully forward.</li> <li>5. Clean or replace the air-cleaner elements.</li> <li>6. Install the wire on the spark plug.</li> <li>7. Install a new, correctly gapped spark plug.</li> <li>8. Contact your Authorized Service Dealer.</li> </ol>
The engine loses power.	<ol style="list-style-type: none"> <li>1. The engine load is excessive.</li> <li>2. The air cleaner is dirty.</li> <li>3. The oil level in the crankcase is low.</li> <li>4. The cooling fins and air passages under the engine blower housing are plugged.</li> <li>5. The spark plug is pitted, fouled, or the gap is incorrect.</li> <li>6. Dirt, water, or stale fuel is in the fuel system.</li> </ol>	<ol style="list-style-type: none"> <li>1. Reduce the ground speed.</li> <li>2. Clean or replace the air-cleaner elements.</li> <li>3. Check and add oil to the crankcase.</li> <li>4. Remove any obstructions from the cooling fins and air passages.</li> <li>5. Install a new, correctly gapped spark plug.</li> <li>6. Contact your Authorized Service Dealer.</li> </ol>
The engine overheats.	<ol style="list-style-type: none"> <li>1. The engine load is excessive.</li> <li>2. The oil level in crankcase is low.</li> <li>3. The cooling fins and air passages under the engine blower housing are plugged.</li> </ol>	<ol style="list-style-type: none"> <li>1. Reduce the ground speed.</li> <li>2. Check and add oil to the crankcase.</li> <li>3. Remove any obstructions from the cooling fins and air passages.</li> </ol>
There is abnormal vibration.	<ol style="list-style-type: none"> <li>1. The engine mounting bolts are loose.</li> </ol>	<ol style="list-style-type: none"> <li>1. Tighten the engine mounting bolts.</li> </ol>
The machine does not drive.	<ol style="list-style-type: none"> <li>1. The hydraulic-fluid level is low.</li> <li>2. The tow valves are open.</li> <li>3. The hydraulic system is damaged.</li> </ol>	<ol style="list-style-type: none"> <li>1. Check and add hydraulic fluid.</li> <li>2. Close the tow valves.</li> <li>3. Contact your Authorized Service Dealer.</li> </ol>
The grinder does not turn.	<ol style="list-style-type: none"> <li>1. A chunk of wood or a rock is caught in the grinder.</li> <li>2. The grinder drive system is damaged.</li> <li>3. The hydraulic system is obstructed, contaminated, or damaged.</li> </ol>	<ol style="list-style-type: none"> <li>1. Shut off the engine and remove the obstruction with a stick.</li> <li>2. Contact your Authorized Service Dealer.</li> <li>3. Contact your Authorized Service Dealer.</li> </ol>
The grinder does not cut fast enough.	<ol style="list-style-type: none"> <li>1. The teeth are worn.</li> <li>2. The hydraulic system is overheated.</li> <li>3. The hydraulic system is obstructed, contaminated, or damaged.</li> </ol>	<ol style="list-style-type: none"> <li>1. Rotate or replace the teeth.</li> <li>2. Shut down and allow the system to cool.</li> <li>3. Contact your Authorized Service Dealer.</li> </ol>

# Schematics

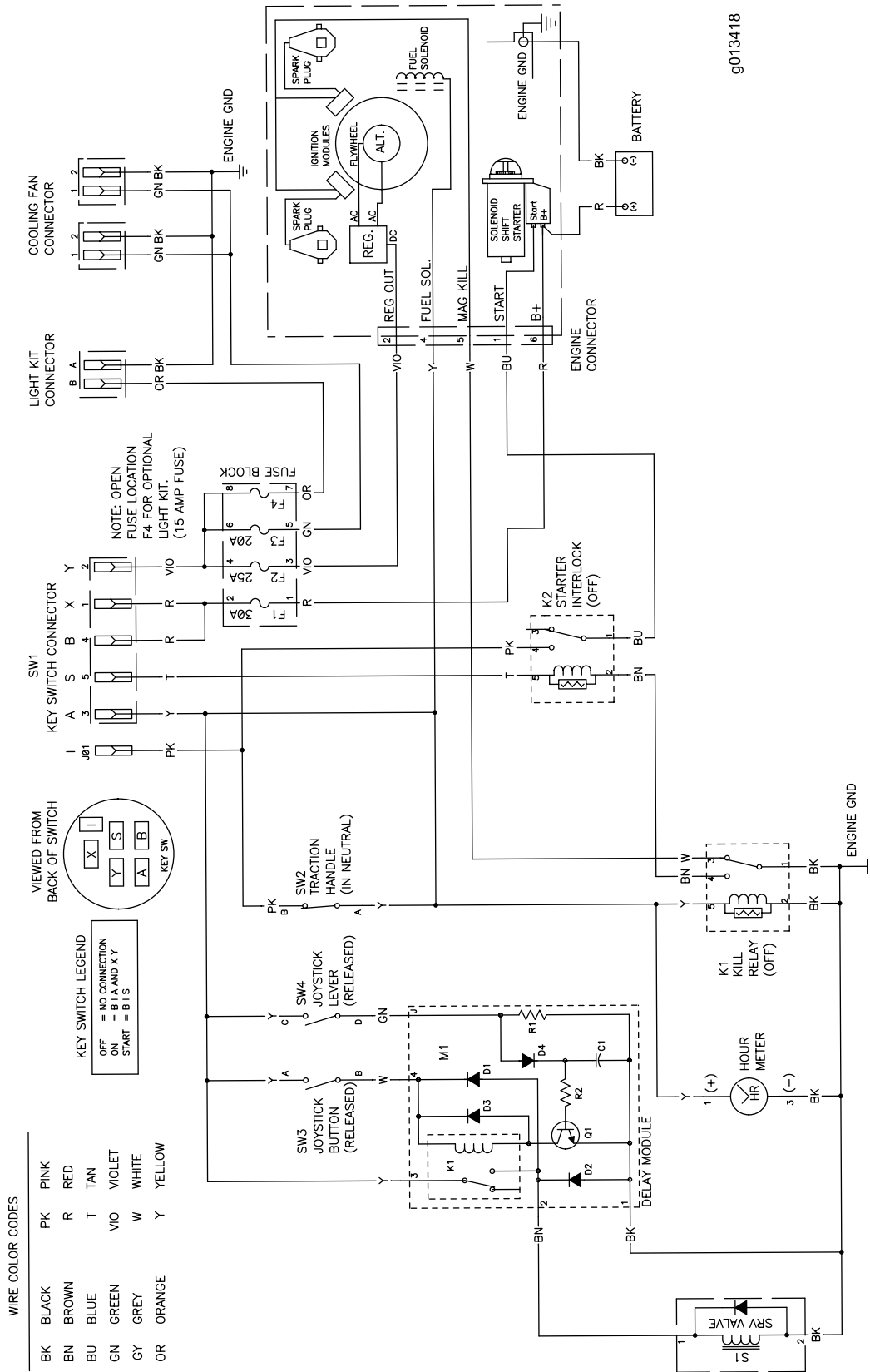

9013418

Electrical Schematic (Rev. A)

9013418

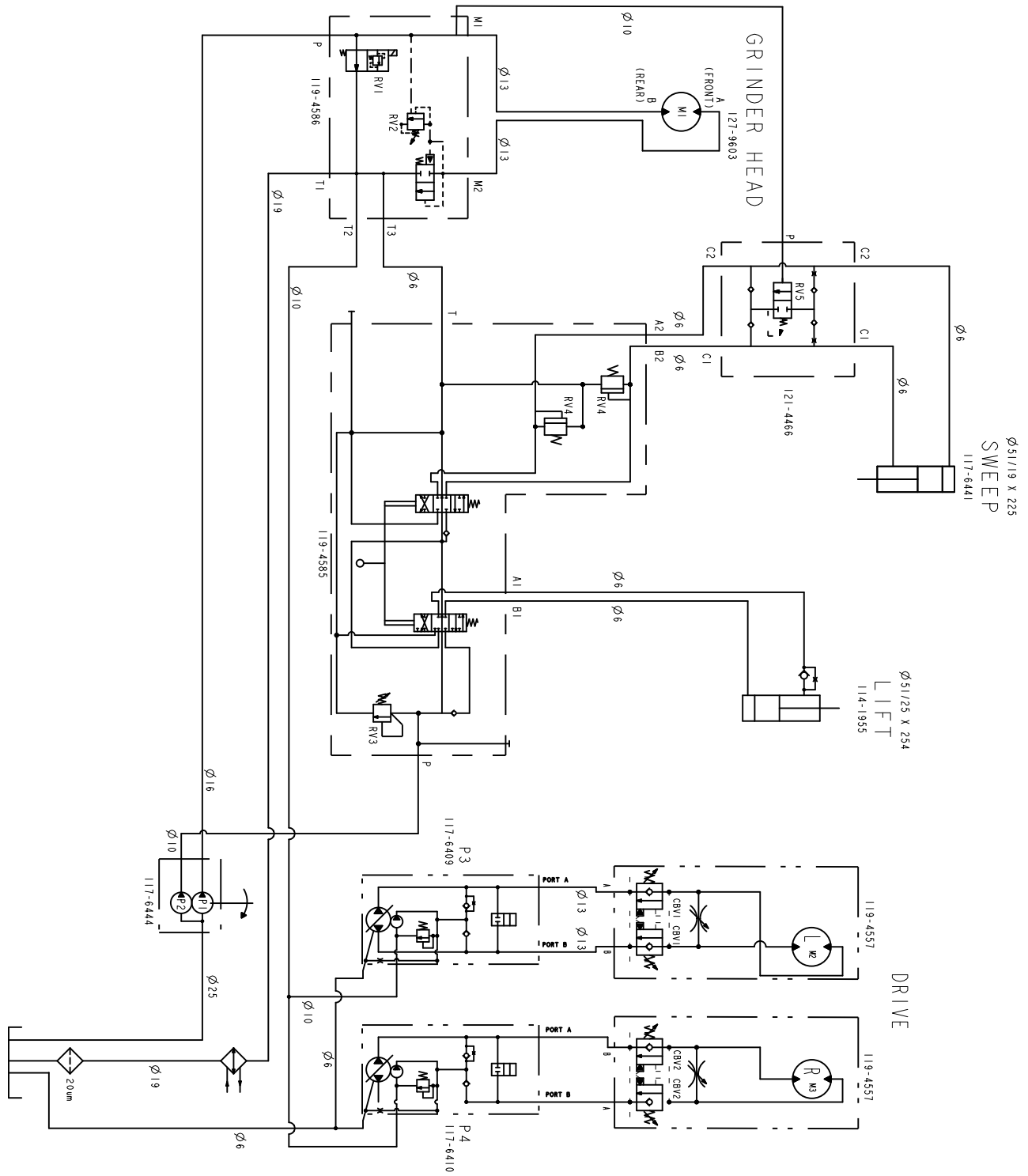

G025169

g025169

Hydraulic Schematic (Rev. A)

**Notes:**

**Notes:**

## **European Privacy Notice**

### **The Information Toro Collects**

Toro Warranty Company (Toro) respects your privacy. In order to process your warranty claim and contact you in the event of a product recall, we ask you to share certain personal information with us, either directly or through your local Toro company or dealer.

The Toro warranty system is hosted on servers located within the United States where privacy law may not provide the same protection as applies in your country.

**BY SHARING YOUR PERSONAL INFORMATION WITH US, YOU ARE CONSENTING TO THE PROCESSING OF YOUR PERSONAL INFORMATION AS DESCRIBED IN THIS PRIVACY NOTICE.**

### **The Way Toro Uses Information**

Toro may use your personal information to process warranty claims, to contact you in the event of a product recall and for any other purpose which we tell you about. Toro may share your information with Toro's affiliates, dealers or other business partners in connection with any of these activities. We will not sell your personal information to any other company. We reserve the right to disclose personal information in order to comply with applicable laws and with requests by the appropriate authorities, to operate our systems properly or for our own protection or that of other users.

### **Retention of your Personal Information**

We will keep your personal information as long as we need it for the purposes for which it was originally collected or for other legitimate purposes (such as regulatory compliance), or as required by applicable law.

### **Toro's Commitment to Security of Your Personal Information**

We take reasonable precautions in order to protect the security of your personal information. We also take steps to maintain the accuracy and current status of personal information.

### **Access and Correction of your Personal Information**

If you would like to review or correct your personal information, please contact us by email at [legal@toro.com](mailto:legal@toro.com).

## **Australian Consumer Law**

Australian customers will find details relating to the Australian Consumer Law either inside the box or at your local Toro Dealer.

# California Proposition 65 Warning Information

## What is this warning?

You may see a product for sale that has a warning label like the following:



**WARNING: Cancer and Reproductive Harm—[www.p65Warnings.ca.gov](http://www.p65Warnings.ca.gov).**

## What is Prop 65?

Prop 65 applies to any company operating in California, selling products in California, or manufacturing products that may be sold in or brought into California. It mandates that the Governor of California maintain and publish a list of chemicals known to cause cancer, birth defects, and/or other reproductive harm. The list, which is updated annually, includes hundreds of chemicals found in many everyday items. The purpose of Prop 65 is to inform the public about exposure to these chemicals.

Prop 65 does not ban the sale of products containing these chemicals but instead requires warnings on any product, product packaging, or literature with the product. Moreover, a Prop 65 warning does not mean that a product is in violation of any product safety standards or requirements. In fact, the California government has clarified that a Prop 65 warning "is not the same as a regulatory decision that a product is 'safe' or 'unsafe.'" Many of these chemicals have been used in everyday products for years without documented harm. For more information, go to <https://oag.ca.gov/prop65/faqs-view-all>.

A Prop 65 warning means that a company has either (1) evaluated the exposure and has concluded that it exceeds the "no significant risk level"; or (2) has chosen to provide a warning based on its understanding about the presence of a listed chemical without attempting to evaluate the exposure.

## Does this law apply everywhere?

Prop 65 warnings are required under California law only. These warnings are seen throughout California in a wide range of settings, including but not limited to restaurants, grocery stores, hotels, schools, and hospitals, and on a wide variety of products. Additionally, some online and mail order retailers provide Prop 65 warnings on their websites or in catalogs.

## How do the California warnings compare to federal limits?

Prop 65 standards are often more stringent than federal and international standards. There are various substances that require a Prop 65 warning at levels that are far lower than federal action limits. For example, the Prop 65 standard for warnings for lead is 0.5 µg/day, which is well below the federal and international standards.

## Why don't all similar products carry the warning?

- Products sold in California require Prop 65 labelling while similar products sold elsewhere do not.
- A company involved in a Prop 65 lawsuit reaching a settlement may be required to use Prop 65 warnings for its products, but other companies making similar products may have no such requirement.
- The enforcement of Prop 65 is inconsistent.
- Companies may elect not to provide warnings because they conclude that they are not required to do so under Prop 65; a lack of warnings for a product does not mean that the product is free of listed chemicals at similar levels.

## Why does Toro include this warning?

Toro has chosen to provide consumers with as much information as possible so that they can make informed decisions about the products they buy and use. Toro provides warnings in certain cases based on its knowledge of the presence of one or more listed chemicals without evaluating the level of exposure, as not all the listed chemicals provide exposure limit requirements. While the exposure from Toro products may be negligible or well within the "no significant risk" range, out of an abundance of caution, Toro has elected to provide the Prop 65 warnings. Moreover, if Toro does not provide these warnings, it could be sued by the State of California or by private parties seeking to enforce Prop 65 and subject to substantial penalties.