

FORM NO. 3321-244 GB



MODEL NO. 03706—80001 & UP
MODEL NO. 03707—80001 & UP

**OPERATOR'S
MANUAL**

REELMASTER® 4000-D
TRACTION UNITS



This operator's manual has instructions on safety, operation, and maintenance.

This manual emphasizes safety, mechanical and general product information. DANGER, WARNING and CAUTION identify safety messages. Whenever the triangular safety alert symbol appears, understand the safety message that follows. "IMPORTANT" highlights special mechanical information and "NOTE" emphasizes general product information worthy of special attention.

IDENTIFICATION AND ORDERING

MODEL AND SERIAL NUMBER

The model and serial number for the traction unit is on a plate that is mounted on the left front frame member. The model and serial number for the cutting unit is on a plate that is mounted on the top front of the center cutting unit. Use model and serial number in all correspondence and when ordering parts.

To order replacement parts from an authorized TORO Distributor, supply the following information:

1. Model and serial numbers of the machine.
2. Part number, description and quantity of parts desired.

NOTE: Do not order by reference number if a parts catalog is being used; use the part number.

Table of Contents

	Page
Safety	3
Specifications	9
Before Operating	11
Controls	13
Operating	17
Maintenance	22

Safety

Training

1. Read the instructions carefully. Be familiar with the controls and the proper use of the equipment.
2. Never allow children or people unfamiliar with these instructions to use the lawn mower. Local regulations may restrict the age of the operator.
3. Never mow while people, especially children, or pets are nearby.
4. Keep in mind that the operator or user is responsible for accidents or hazards occurring to other people or their property.
5. Do not carry passengers.
6. All drivers should seek and obtain professional and practical instruction. Such instruction should emphasize:
 - the need for care and concentration when working with ride-on machines;
 - control of a ride-on machine sliding on a slope will not be regained by the application of the brake. The main reasons for loss of control are:
 - insufficient wheel grip;
 - being driven too fast;
 - inadequate braking;
 - the type of machine is unsuitable for its task;
 - lack of awareness of the effects of ground conditions, especially slopes;
 - incorrect hitching and load distribution.

Preparation

1. While mowing, always wear substantial footwear and long trousers. Do not operate the equipment when barefoot or wearing open sandals.
2. Thoroughly inspect the area where the equipment is to be used and remove all objects which may be thrown by the machine.

3. **WARNING—Petrol is highly flammable.**

- Store fuel in containers specifically designed for this purpose.
- Refuel outdoors only and do not smoke while refueling.
- Add fuel before starting the engine. Never remove the cap of the fuel tank or add petrol while the engine is running or when the engine is hot.
- If petrol is spilled, do not attempt to start the engine but move the machine away from the area of spillage and avoid creating any source of ignition until petrol vapors have dissipated.
- Replace all fuel tanks and container caps securely.

4. Replace faulty silencers.

Operation

1. Do not operate the engine in a confined space where dangerous carbon monoxide fumes can collect.
2. Mow only in daylight or in good artificial light.
3. Before attempting to start the engine, disengage all blade attachment clutches and shift into neutral.
4. Do not use on slopes of more than:
 - Never mow side hills over 5°
 - Never mow uphill over 10°
 - Never mow downhill over 15°
5. Remember there is no such thing as a “safe” slope. Travel on grass slopes requires particular care. To guard against overturning:
 - do not stop or start suddenly when going up or downhill;
 - engage the clutch slowly, and always keep the machine in gear, especially when travelling downhill;
 - machine speeds should be kept low on slopes and during tight turns;

- stay alert for bumps and hollows and other hidden hazards;
 - never mow across the face of the slope, unless the lawn mower is designed for this purpose.
6. Use care when pulling loads or using heavy equipment.
 - Use only approved drawbar hitch points.
 - Limit loads to those you can safely control.
 - Do not turn sharply. Use care when reversing.
 - Use counterweight(s) or wheel weights when suggested in the instruction handbook.
 7. Watch out for traffic when crossing or near roadways.
 8. Stop the blades rotating before crossing surfaces other than grass.
 9. When using any attachments, never direct discharge of material toward bystanders nor allow anyone near the machine while in operation .
 10. Never operate the lawn mower with defective guards, shields or without safety protective devices in place.
 11. Do not change the engine governor settings or overspeed the engine. Operating the engine at excessive speeds may increase the hazard of personal injury.
 12. Before leaving the operator's position:
 - disengage the power take-off and lower the attachments;
 - change into neutral and set the parking brake;
 - stop the engine and remove the key.
 13. Disengage the drive to attachments when transporting or not in use.
 14. Stop the engine and disengage the drive to the attachment
 - before refueling;
 - before removing the grass catcher;
 - before making height adjustments unless the

adjustment can be made from the operator's position.

- before clearing blockages;
- before checking, cleaning or working on the lawnmower;
- after striking a foreign object. Inspect the lawnmower for damage and make repairs before restarting and operating the equipment.

15. Reduce the throttle setting during engine runout and, if the engine is provided with a shutoff valve, turn the fuel off at the conclusion of mowing.

Maintenance and Storage

1. Keep all nuts, bolts and screws tight to be sure the equipment is in safe working condition.
2. Never store the equipment with petrol in the tank inside a building where fumes may reach an open flame or spark.
3. Allow the engine to cool before storing in any enclosure.
4. To reduce the fire hazard, keep the engine, silencer, battery compartment and petrol storage area free of grass, leaves, or excessive grease.
5. Check the grass catcher frequently for wear or deterioration.
6. Replace worn or damaged parts for safety.
7. If the fuel tank has to be drained, this should be done outdoors.
8. Be careful during adjustment of the machine to prevent entrapment of the fingers between moving blades and fixed parts of the machine.
9. On multi-bladed machines, take care as rotating one blade can cause other blades to rotate.
10. When the machine is to be parked, stored or left unattended, lower the cutting means unless a positive mechanical lock is used.

Sound & Vibration Levels

Sound Levels

This unit has an equivalent continuous A-weighted sound pressure at the operator ear of: 90 dB(A), based on measurements of identical machines per SAE J1174—Mar 85 procedures.

This unit has a sound power level of 105 dB(A)/1pW, based on measurements of identical machines per procedures outlined in Directive 79/113/EEC and amendments

Vibration Levels

This unit has a vibration level of 4.5 m/s² at the posterior, based on measurements of identical machines per ISO 2631 procedures.

This unit does not exceed a vibration level of 0.5 m/s² at the posterior based on measurements of identical machines per ISO 2631 procedures.

Symbol Glossary

Caustic liquids, chemical burns to fingers or hand	Poisonous fumes or toxic gases, asphyxiation	Electrical shock, electrocution	High pressure fluid, injection into body	High pressure spray, erosion of flesh	High pressure spray, erosion of flesh	Crushing of fingers or hand, force applied from above	Crushing of toes or foot, force applied from above



Crushing of whole body, applied from above	Crushing of torso, force applied from side	Crushing of fingers or hand, force applied from side	Crushing of leg, force applied from side	Crushing of whole body	Crushing of head, torso and arms	Cutting of fingers or hand	Cutting of foot

Cutting or entanglement of foot, rotating auger	Severing of foot, rotating knives	Severing of fingers or hand, impeller blade	Wait until all machine components have completely stopped before touching them	Severing of fingers or hand, engine fan	Whole body entanglement, implement input drive line	Fingers or hand entanglement, chain drive

Hand & arm entanglement, belt drive	Thrown or flying objects, whole body exposure	Thrown or flying objects, face exposure	Runover/back-over, (relevant machine to appear in dashed box)	Machine tipping, riding mower	Machine rollover, ROPS (relevant machine to appear in dashed box)	Stored energy hazard, kickback or upward motion	Hot surfaces, burns to fingers or hands

Explosion	Fire or open flame	Secure lifting cylinder with locking device before getting in hazardous area	Stay a safe distance from the machine	Stay clear of articulation area while engine is running	Do not open or remove safety shields while engine is running	Do not step on loading platform if PTO is connected to tractor & engine is running	Do not step

Shut off engine & remove key before performing maintenance or repair work	Riding on this machine is allowed only on a passenger seat & only if the driver's view is not hindered	Consult technical manual for proper service procedures	Fasten seat belts	Safety alert triangle	outline safety alert symbol	Read operator's manual

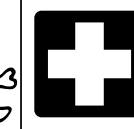
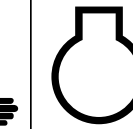
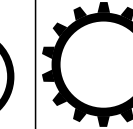
							
Eye protection must be worn	Head protection must be worn	Hearing protection must be worn	Caution, toxic risk	First aid	Flush with water	Engine	Transmission

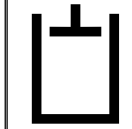
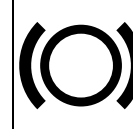
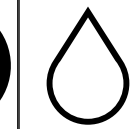
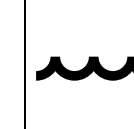
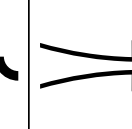
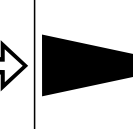
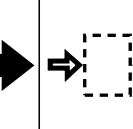
							
Fire, open light & smoking prohibited	Hydraulic system	Brake system	Oil	Coolant (water)	Intake air	Exhaust gas	Pressure

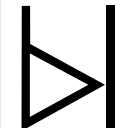
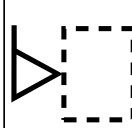
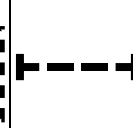
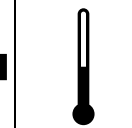
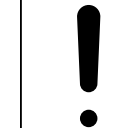
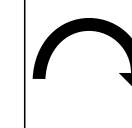
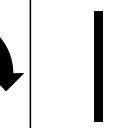
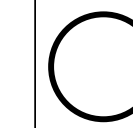
							
Level indicator	Liquid level	Filter	Temperature	Failure/ Malfunction	Start switch/ mechanism	On/start	Off/stop

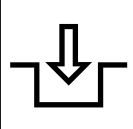
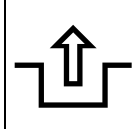
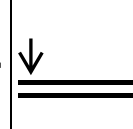
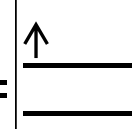
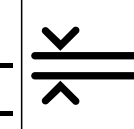
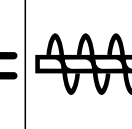
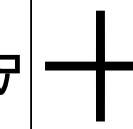
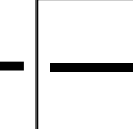
							
Engage	Disengage	Attachment lower	Attachment raise	Spacing distance	Snow thrower, collector auger	Plus/increase/ positive polarity	Minus/decrease/ negative polarity

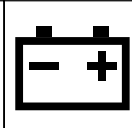
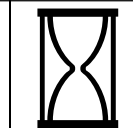
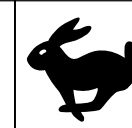
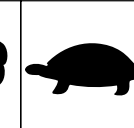
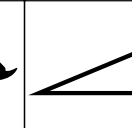
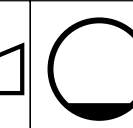
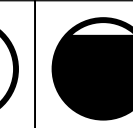
							
Horn	Battery charging condition	Hourmeter/elapsed operating hours	Fast	Slow	Continuous variable, linear	Volume empty	Volume full

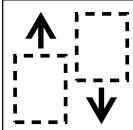
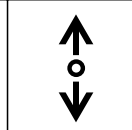
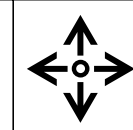
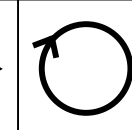
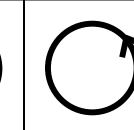
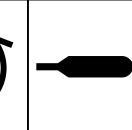
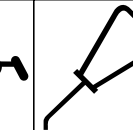
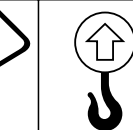
							
Machine travel direction, forward/rearward	Control lever operating direction, dual direction	Control lever operating direction, multiple direction	Clockwise rotation	Counter-clockwise rotation	Grease lubrication point	Oil lubrication point	Lift point

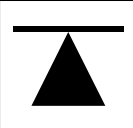
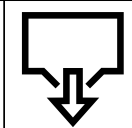
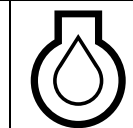
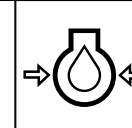
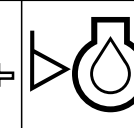
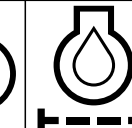
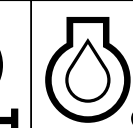
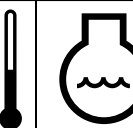
							
Jack or support point	Draining/ emptying	Engine lubricating oil	Engine lubricating oil pressure	Engine lubricating oil level	Engine lubricating oil filter	Engine lubricating oil temperature	Engine coolant

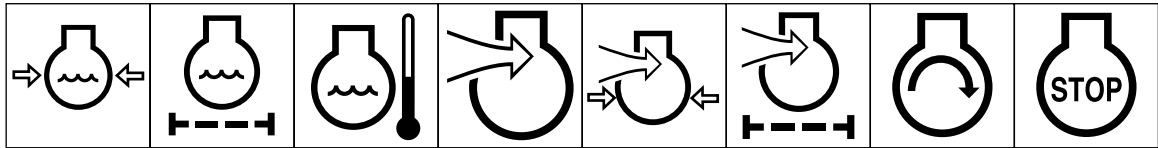

Engine coolant pressure Engine coolant filter Engine lubricating oil pressure Engine intake/combustion air Engine intake/combustion air pressure Engine intake/air filter Engine start Engine stop

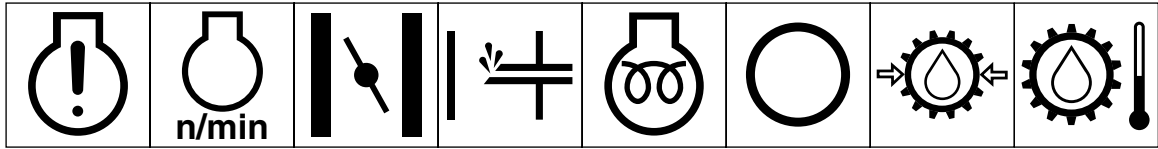

Engine failure/malfunction Engine rotational speed/frequency Choke Primer (start aid) Electrical preheat (low temperature start aid) Transmission oil Transmission oil pressure Transmission oil temperature

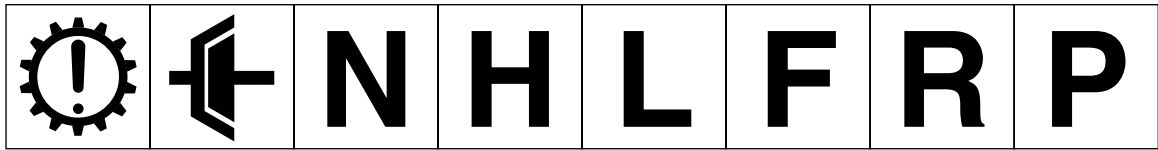

Transmission failure/malfunction Clutch Neutral High Low Forward Reverse Park

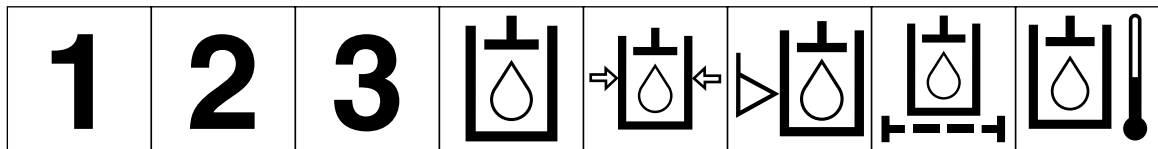

First gear Second gear Third gear (other #'s may be used until the maximum # of forward gears is reached.) Hydraulic oil Hydraulic oil pressure Hydraulic oil level Hydraulic oil filter Hydraulic oil temperature

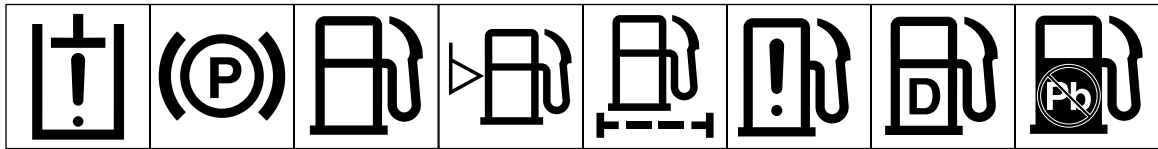

Hydraulic oil failure/malfunction Parking brake Fuel Fuel level Fuel filter Fuel system failure/malfunction Diesel fuel Unleaded fuel

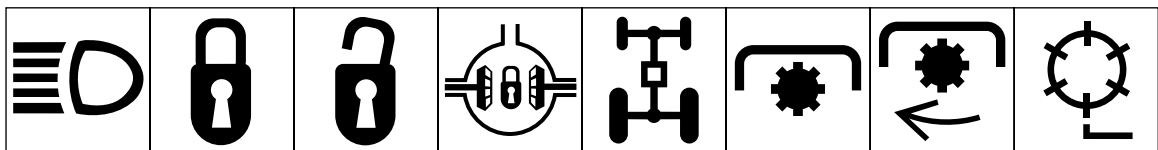

Headlights Lock Unlock Differential lock 4-Wheel drive Power Take-Off Power Take-Off, rotational speed Reel cutting element

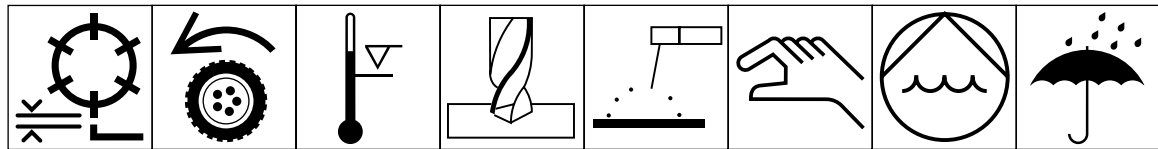

Reel cutting element, height adjustment Traction Above working temperature range Drilling Manual metal arc welding Manual 0356 Water pump 0626 Keep dry

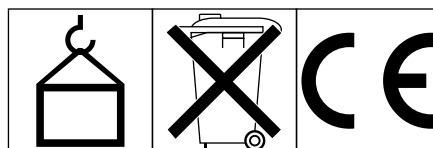

0430 weight Do not dispose in the garbage CE logo

Specifications

Engine: Kubota, four-cycle, four-cylinder, 134 cu-in. displacement, water-cooled diesel engine. Rated 40 hp @ 2,300 rpm, 23:1 compression ratio. Low idle—1,200 rpm, high idle—2,500 rpm. Injection Timing -17° – -18° BTDC. Oil capacity is 8 qt (7.6 L) with filter.

Cooling System: Capacity is 3.7 gal. (14 L) of 50/50 mixture of ethylene glycol anti-freeze.

Fuel System: Capacity is 15 gal. (56.8 L) of #2 diesel fuel.

Hydraulic System: Reservoir capacity is 9.3 gal. (35.2 L) and total system capacity is 18.2 gal. (69 L). Replaceable breather element. Replaceable spin-on filter element.

Traction System: Ground speed is 0–12.5 mph (0–20 km/h).

Cutting Unit Drive System: Adjustable reel speed to match the grass clip to the ground speed. Backlap reel speed is 385 rpm.

Seat: Adjusts 6 in. (15.2 cm) forward and backward. Adjustable backrest with three-positions for operator weight. Integral seat switch in the bottom of the seat cushion.

Diagnostic System: Test ports for the traction system, cutting unit drive system, lift/counterbalance, lift/relief, steering circuits and charge pressure.

Steering System: Automotive type, full power.

Brakes: The hand brake automatically locks the traction linkage in neutral. With the traction motor wheel locks engaged, twin disc brakes provide positive emergency braking.

Electrical System: 12-volt, 66-amp hour (DIN) battery and 40-amp alternator. Negative ground.

Interlock System: Designed to stop the engine if you get off the seat while the cutting unit drive lever is either in forward or reverse. Prevents the engine from starting unless the parking brake is engaged, the traction pedal is in neutral and the cutting units are disengaged. Low

hydraulic oil level and high engine temperature protection systems stop the engine.

Warning Systems:

- Water in fuel
- Hydraulic oil filter
- Engine coolant temperature
- Engine oil pressure
- Voltage indicator
- Air cleaner clogged
- Hydraulic oil temperature
- Hydraulic oil level

General Specifications:

Width-of-Cut:

- 5 Cutting Units 137 in. (348 cm)
- 4 Cutting Units 110 in. (279 cm)
- 3 Cutting Units 83 in. (211 cm)
- 1 Cutting Unit 29-1/2 in. (75 cm)

Overall Width:

Cutting Units Raised	91-1/2 in. (232 cm)
Cutting Units Down	147 in. (373 cm)
Overall Length:	110 in. (282 cm)

Height: 55-1/2 in. (141 cm)

Ground Clearance: approx. 7 in. (17.8 cm)

Recommended Height-of-Cut:

5-Blade Cutting Unit:	1–3 in. (25–76 mm)
7-Blade Cutting Unit:	3/8–1-3/4 in. (9.5–44 mm)
11-Blade Cutting Unit:	3/8–3/4 in. (9.5–19 mm)

Wheel Tread: 53 in. (135 cm)

Wheel Base: 57 in. (145 cm)

Operating Circle: 60 in. (152 cm)

Dry Weight: 4,360 lbs. (1,627 kg)

Reel Speed: 800–1,000 rpm

Clip (variable to match conditions):

5-Blade Cutting Unit:	.176 in. per mph (0.352 in. at 2 mph-1.32 in. at 7.5 mph)
-----------------------	--

7-Blade Cutting Unit: .126 in. per mph
(0.252 in. at 2 mph -945 in.at 7.5 mph)

11-Blade Cutting Unit: .080 in. per mph
(0.16 in. at 2 mph.600 in. at 7.5 mph)

Fluids

Engine Oil: SAE 10W30 SF, CD

Diesel Fuel: #2

Cooling System: 50/50 Water & Anti-Freeze

Hydraulic Oils (Interchangeable): Mobil DTE 26/Shell Tellus
68 Equivalent*

*Equivalent hydraulic oils (interchangeable)

Mobil	DTE 15 M
Amoco	Rykon Oil #68
Conoco	Super Hydraulic Oil 68
Exxon	Nuto H 68
Kendall	Kenoil R & 0 AW 68
Pennzoil	Penreco 68
Phillips	Magnus A 68
Standard	Energol HLP 68
Sun	Sunvis 831 WR
Union	Unax AW 68

Before Operating

CHECK THE ENGINE OIL DAILY



CAUTION

Before servicing the machine, stop the engine and remove the key from the switch.

1. Park the machine on a level surface.
2. Release the engine cover latches (Fig. 1) and open the engine cover.
3. Check the dipstick (Fig. 2); the oil level should be up to the FULL mark.
4. If the oil is below the FULL mark, remove the fill cap (Fig. 3) and add SAE 10W-30 oil until the level reaches the FULL mark. **DO NOT OVERFILL.** Crankcase capacity is 6.9 qt. (6.5 l) with the filter.
5. Install the oil fill cap and dipstick.
6. Close the engine cover and secure it with the latches.

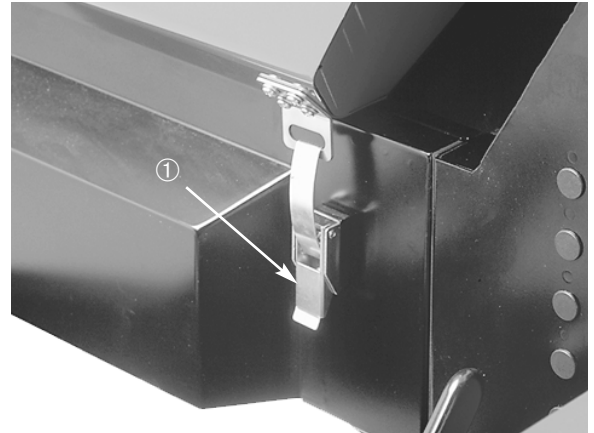

Figure 1

1. Engine Cover Latch

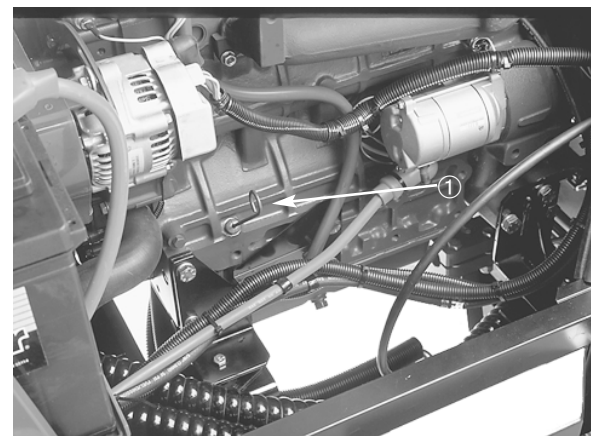

Figure 2

1. Dipstick

CHECK THE COOLING SYSTEM DAILY



CAUTION

If the engine is hot, pressurized coolant can escape and cause burns when you remove the radiator cap. Remove the cap slowly and carefully if the engine coolant is hot.

Capacity of the system is 3.7 gal. (14 l).

1. Remove the radiator cap (Fig. 4). The coolant should be one inch from the bottom of the fill hole.
2. The radiator should be filled to the top of the filler neck and the expansion tank filled to the marks on its side.

Use a 50/50 mixture of water and ethylene glycol anti-freeze. **DO NOT USE WATER ONLY OR ALCOHOL/METHANOL BASE COOLANTS.**

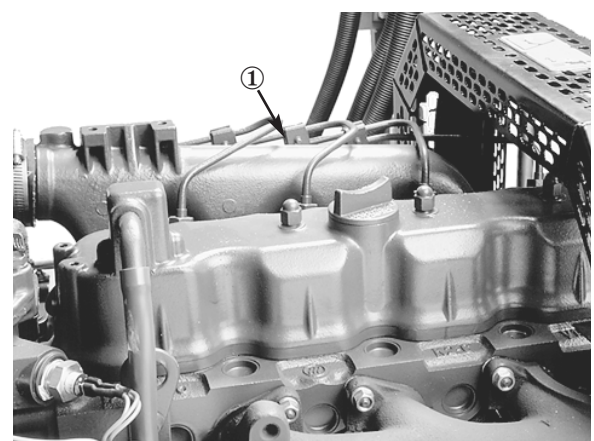

Figure 3

1. Oil Fill Cap

FILL THE FUEL TANK (Fig. 5).

DANGER

Because diesel fuel is flammable, use caution when storing or handling it. Do not smoke while filling the fuel tank. Do not fill the fuel tank while the engine is running, hot, or when the machine is in an enclosed area. Always fill the fuel tank outside and wipe up any spilled diesel fuel before starting the engine. Store fuel in a clean, safety-approved container and keep the cap in place. Use diesel fuel for the engine only; not for any other purpose.



Figure 4

1. Expansion tank

CHECK THE HYDRAULIC SYSTEM DAILY

The oil level should be even with the arrows in the sight glass (Fig. 6) when checking warm oil. The oil will be 64-127 mm (1/4 to 1/2) inches below the arrows when cold.

CHECK THE REEL-TO-KNIFE CONTACT DAILY

There must be light contact across the full length of the reel and knife. Refer to your cutting unit manual for adjustment instructions.

CHECK THE TIRE PRESSURE DAILY

For normal mowing conditions and use these tire pressures: 90 kPa front and 103 kPa rear. When the turf is either wetter or drier than normal, you may need to change the tire pressure. On hard turf, use high tire pressure 124kPa front and rear. When turf is soft, use low pressure (62kPa front and 83 kPa rear.

IMPORTANT: Maintain even pressure in the two front tires and both rear tires. Do not exceed 16 kph (10 mph) transport speed (for extended periods) when the tire pressure is 83kPa or less because the tires may be damaged. Maximum transport speed can be used when the front tire pressure is higher than 90 kPa.

REAR BALLAST

IMPORTANT: If a puncture occurs in a tire with calcium chloride, remove the unit from the turf area quickly and immediately soak the affected area with water.



Figure 5

1. Radiator Cap
2. Fuel Tank Cap

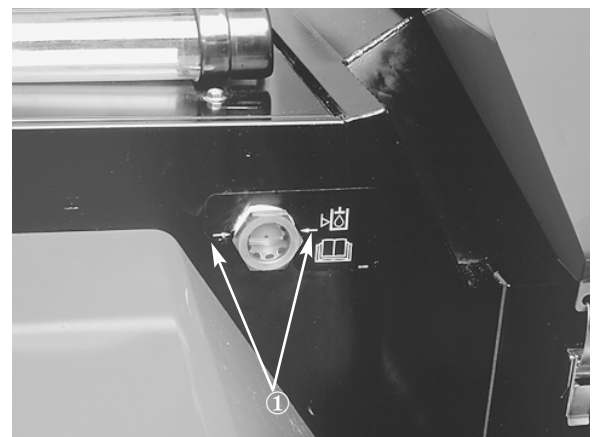

Figure 6

1. Sight Glass Arrows

Controls

Seat Adjustment (Fig. 7) The seat adjusting lever allows 15 cm (5.9 inches) fore and aft adjustment in 15 mm increments.

Arm Rest (Fig. 8) The arm rest pivots up and down.

Backrest Knob (Fig. 8)—The backrest knob adjusts the backrest angle from 5–20 degrees.

Suspension Lever (Fig. 8). The suspension lever adjusts the seat to the operator's weight. Use the up position for light-weight operators, the down position for heavy-weight operators. The backrest cushion and bottom seat cushion are removable.



Figure 7

1. Seat Adjusting Lever



CAUTION

To make sure the interlock switch operates correctly, the seat suspension must be set for the weight of each operator. If the suspension is not set correctly, the engine will run intermittently and tend to stall. To correct this, set the suspension lighter.

Warning Light Test Button (Fig. 9)—Before operating, press the test button. All lights on the steering tower should illuminate. Any light that does not come on indicates an electrical malfunction that should be repaired immediately. The oil pressure and no-charge indicator lights illuminate when turning the key switch “ON”.

Hydraulic and Engine Indicator Lights (Fig. 9)—If these lights come on, stop the machine and make repairs immediately.

Engine Oil Pressure Warning (Fig. 9)—Dangerously low engine oil pressure is indicated by both a warning indicator light and an audible signal. When this occurs, stop the engine immediately and correct the problem.

Fuel System Warning (Fig. 9)—A warning indicator light and audible signal warn of excess water in the fuel system.

Coolant Temperature Warning (Fig. 9)—If the engine coolant temperature exceeds 221° F (105° C) a warning indicator light illuminates and audible signal sounds. The engine shuts down if the coolant's temperature exceeds 230° F (110° C). The switch resets automatically when system and engine cool down.

No Charge Warning (Fig. 9)—No charge to the batteries is indicated by a warning indicator light and audible signal.

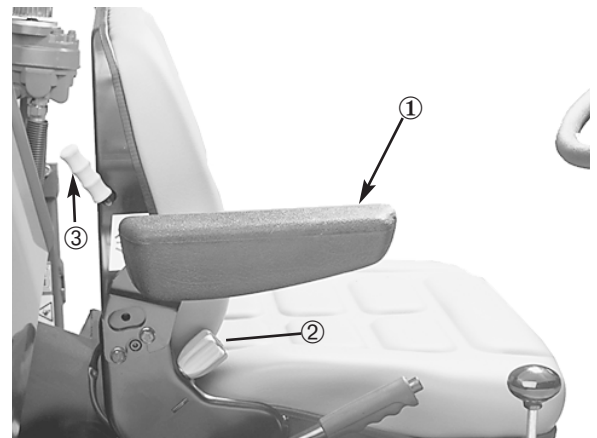

Figure 8

1. Arm Rest
2. Backrest knob
3. Suspension Lever

Hydraulic Oil Temperature Warning (Fig. 9)—A warning indicator light and audible signal warn of excessively high hydraulic temperature.

Hydraulic Oil Level Warning (Fig. 9)—A warning indicator light and audible signal warn of low hydraulic oil level. If the oil level drops further, the engine will automatically stop. The engine cannot be restarted until the oil supply is brought to a safe level.

Hydraulic Oil Filter Warning (Fig. 9)—A warning indicator light and audible signal warn of a clogged hydraulic filter.

Air Cleaner Warning (Fig. 9)—A warning indicator light and audible signal warn that the filter is clogged and in need of service.

Alarm Silence Button (Fig. 9)—Pressing this button silences the alarm. The alarm system will disengage and automatically reset when the problem is corrected or the alarm silence button is pressed.

Traction Pedal (Fig. 10)—Controls forward and reverse operation. Depress the top of the pedal to move forward and the bottom to move backward. The ground speed depends on how far the pedal is depressed.

- For no load, maximum ground speed, fully press the pedal while the throttle is in FAST.
- For maximum power under load or when going uphill, keep the engine rpm high by having the throttle in FAST and the traction pedal held stationary against the ground speed limiter. If the engine rpm begins to decrease due to load, gradually reduce the traction pedal pressure until the engine speed increases.

To stop, reduce foot pressure on the traction pedal and allow it to return to the center position. On extreme downhill slopes, apply pressure to the REVERSE side of the pedal, or operate with your heel on REVERSE and your toe on FORWARD part of the pedal.

Ground Speed Limiter (Fig. 10) controls the traction pedal movement. Limiter lever helps control the rate of grass clip and eliminates sudden speed variations over rough terrain.

IMPORTANT: The cam lever nut (Fig. 9 inset) can be tightened if the limiter stop will not hold traction pedal in desired position.

Transport Latches (Fig. 10 and 11)—Latches secure the

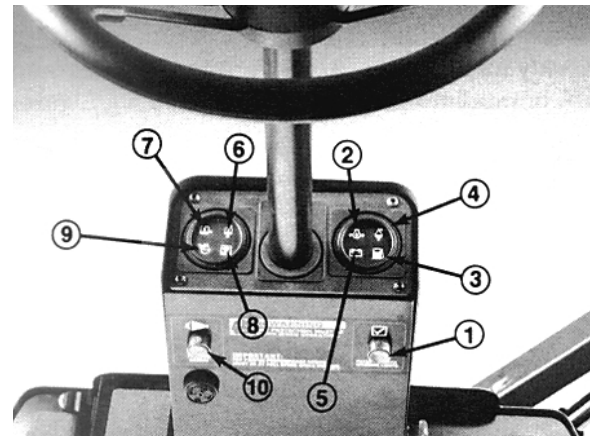

Figure 9

1. Warning light check switch
2. Engine oil pressure warning
3. Fuel system warning
4. Coolant temperature warning
5. No charge warning
6. Hydraulic oil temperature warning
7. Hydraulic oil level warning
8. Hydraulic oil filter warning
9. Air cleaner warning
10. Alarm silence button



Figure 10

1. Top of the traction pedal—forward
2. Bottom of the traction pedal—reverse
3. Speed limiter
4. Transport latch—front cutting units

cutting units in upright position for transport. The latch for the front cutting units is foot-operated (Fig. 10). Hand-operated latches control the center and outside cutting units (Fig. 11).

Cutting Unit Lift Controls (Fig. 12)—The two outside levers raise and lower the two outside cutting units. The center lever raises and lowers the two front and the center cutting units. The engine must be running to lower the cutting units. When the cutting units are lifted, the reels automatically stop. Do not allow the levers to snap-back to neutral, or the cutting units may not float freely.

Engine Override Button (Fig. 12)—When the button is depressed, the engine can be operated after it has overheated and automatically been stopped by the electrical safety system. Use only for short intervals.

Fuel Level Gauge (Fig. 12)—Indicates the amount of fuel in the tank.

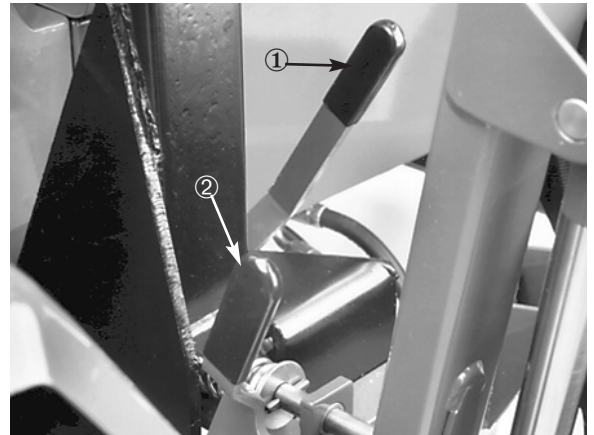

Figure 11

1. Center cutting unit latch
2. Outside cutting unit latch

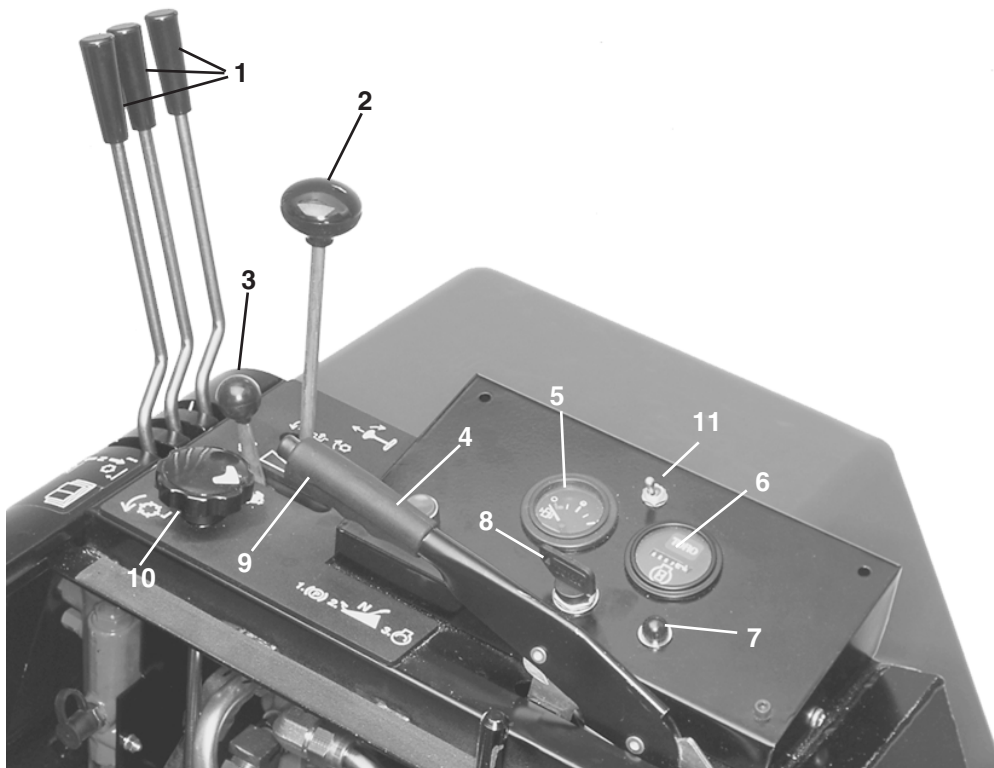

Figure 12

- | | |
|-------------------------------|-----------------------------------|
| 1. Cutting unit lift controls | 7. Engine preheat indicator light |
| 2. Mow/backlap lever | 8. Key switch |
| 3. Throttle | 9. Hand brake |
| 4. Engine over ride button | 10. Reel speed control |
| 5. Fuel gauge | 11. 4-Wheel drive switch |
| 6. Hour meter | |

Hour Meter (Fig. 12)—Indicates total hours that the machine has been operated. **Note:** Lines circling in the small window at the left side of gauge indicate that the hour meter is operating.

Engine Preheat Indicator Light (Fig. 12)—Light turns on when the key is turned to the ON position. Glow plugs engage for 10 seconds, then the light goes off and the engine is ready to start..

Key Switch (Fig. 12)—This switch has three positions: OFF, ON and START. Turn the key to START and release it when the engine begins running. To stop the engine, turn the key to OFF.

Parking Brake Lever (Fig. 12)—Pull the lever up to lock the brake. To release the brake, pull up on the lever, press the button and lower lever. The brake must be engaged to start the engine. Always engage the parking brake before getting off the seat.

Mow-Backlap Lever (Fig. 12)—Move the lever forward to engage the cutting units. Move the lever to the center to stop the cutting units. To backlap the cutting units, lift the lever over stop and hold in the rear position.



CAUTION

Do not move the lever directly between the MOW and BACKLAP positions. Pause briefly in the STOP position.

Reel Speed Control (Fig. 12)—Turn the knob clockwise to increase the reel speed, counter-clockwise to decrease reel speed. Use with the ground speed limiter to get an appropriate rate of grass clip.

Throttle Control (Fig. 12)—Move the control forward to increase the engine speed, backward to decrease speed.

4-Wheel Drive Switch (Fig. 12)—(4-wheel drive model only) Move the switch forward to engage 4-wheel drive. Move the switch to the rear position to disengage 4-wheel drive.

Operating Instructions

STARTING AND STOPPING

1. Sit on the seat, keep your foot off the traction pedal. Make sure the parking brake is engaged (Fig. 11). The traction pedal and the mow/backlap lever must be in neutral.
2. Turn the ignition switch to ON. When the glow plug light goes off, turn the ignition key to start the engine.
3. To stop, disengage and move all controls to neutral and set the parking brake. Raise and latch all cutting units in transport position. Turn the key to OFF and remove it from the switch.

PRIMING THE FUEL SYSTEM

IMPORTANT: The fuel system must be primed when a new engine is started for the first time, if it runs out of fuel or if maintenance is done on the fuel system.

1. Raise the engine cover.
2. Insert a 3/16" hose over the fuel pump bleed screw and run the other end into a container to catch fuel.
3. Loosen the fuel filter bleed plug a few turns (Fig. 13). Pump the priming plunger (Fig. 13) until a steady stream of fuel runs out of the hole in the bleed screw. When the fuel stops foaming, tighten the bleed screw during the downstroke of the priming plunger. Wipe up any spilled fuel.

Note: Priming the fuel filter without opening the bleed screw may damage the priming plunger.

4. Pump the plunger until you feel resistance, then try to start the engine. If the engine doesn't start, repeat step 3.

Note: It may be necessary to bleed the air out of the fuel line between the fuel filter and the injection pump. To do this, loosen the knob (Fig. 14) on the injection pump and repeat the bleeding procedure.

CHECKING THE WARNING INDICATOR LIGHTS

Each day before operating, make sure all warning lights are working.

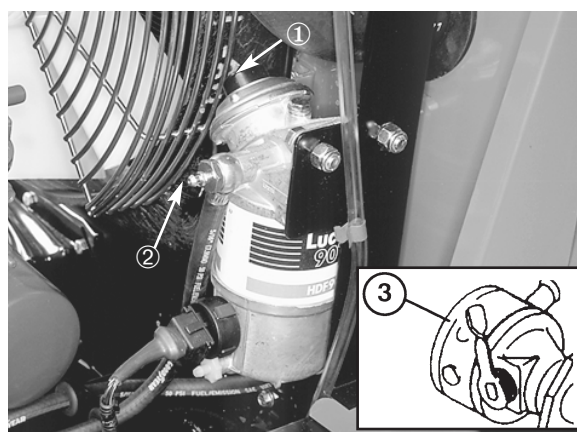

Figure 13

1. Primer plunger
2. Bleed screw
3. Fuel pump



Figure 14

1. Injection pump knob

1. Apply the parking brake, turn the ignition key ON. Push the warning indicator light button (Fig. 15). All lights should illuminate and the alarm will sound.

Note: The alarm will continue to sound until the problem is corrected or until the alarm silence button is pressed. If a second problem is encountered, the alarm will not sound but the indicator light will illuminate.

CHECKING THE INTERLOCK SYSTEM



CAUTION

THE INTERLOCK SWITCHES ARE FOR THE OPERATOR'S PROTECTION, SO DO NOT DISCONNECT THEM. CHECK SWITCH OPERATION DAILY TO MAKE SURE THE INTERLOCK SYSTEM IS OPERATING. IF A SWITCH IS DEFECTIVE, REPLACE IT BEFORE OPERATING. REGARDLESS OF WHETHER THE SWITCHES ARE OPERATING CORRECTLY, REPLACE THEM EVERY TWO YEARS TO ASSURE MAXIMUM SAFETY.



Figure 15

1. Warning indicator light test button

1. In a wide open area free of debris and bystanders, lower the cutting units to the ground. Stop the engine.
2. Sit on the seat and engage the parking brake (Fig. 12). Turn the key and try to start the engine with the Mow/Backlap lever (Fig. 12) in both the MOW and BACKLAP positions. If the engine cranks, there is a malfunction that must be repaired immediately. If the engine does not crank, the cutter drive switch is operating correctly.
3. Sit on the seat and disengage the parking brake. Turn the key and try to start the engine with the Mow/Backlap lever in STOP. If the engine cranks, there is a malfunction that must be repaired immediately. If the engine doesn't crank, the brake switch is operating correctly.
4. Engage the parking brake, start the engine and lower the cutting units. Move the Mow/Backlap lever to MOW. Rise off the seat; the engine should stop within a few seconds, which indicates the interlock system is operating. Also rise off the seat with the lever in BACKLAP. The engine should stop, indicating the interlock system is operating. If the engine does not stop, there is a malfunction that must be repaired immediately.

Note: There is a 1–2 second delay between rising off the

seat and the engine shuts off.

5. Engage the parking brake, move the Mow-Backlap lever to NEUTRAL, start the engine, disengage the hand brake and raise off the seat. If the engine stops, the interlock system is operating. If the engine does not stop, there is a malfunction that must be repaired immediately.

PUSHING OR TOWING THE TRACTION UNIT

In an emergency, the traction unit can be pushed or towed for a very short distance by using the traction pump by-pass valve.

IMPORTANT: Do not push or tow the traction unit faster than 2 to 3 mph (3 to 5 km/hr) because the hydraulic system may be damaged. If the traction unit must be moved a considerable distance, transport it on a truck or trailer.

1. Remove the retainer clip from the seat lock rod (Fig. 16)
2. Raise the seat and support it in an upright position with the seat support rod (Fig. 17)
3. Lift and remove the front panel.
4. Turn the by-pass valve 90 degrees (Fig. 18). Opening the valve opens an internal passage in the traction pump, bypassing hydraulic oil. Because the oil is by-passed, the traction unit can be moved without damaging the hydraulic system.

IMPORTANT: Make sure that the hand brake is engaged before opening the by-pass valve.

5. Before starting the engine, close the by-pass valve. Do not start the engine when the valve is open.

IMPORTANT: Running the machine with the bypass valve open will cause the hydraulic system to overheat.



CAUTION

The vehicle will roll with the front wheel motors disengaged. The vehicle must be on a level surface or the wheels must be blocked. There is no effective braking with the wheel motors disengaged.

If towing with the front wheel motors disengaged, the Tow Bar Assembly, Toro part no. 58-7020, must be used.

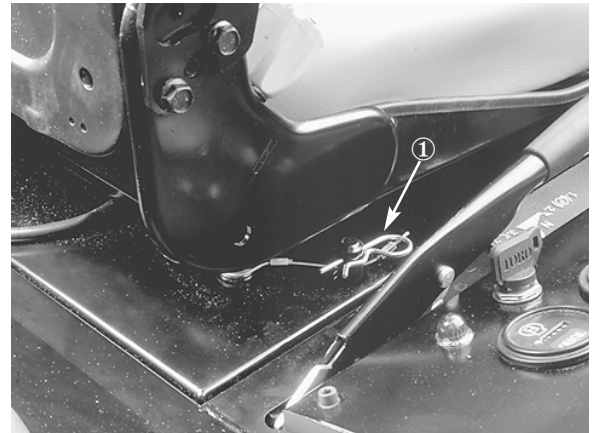

Figure 16

1. Retainer clip

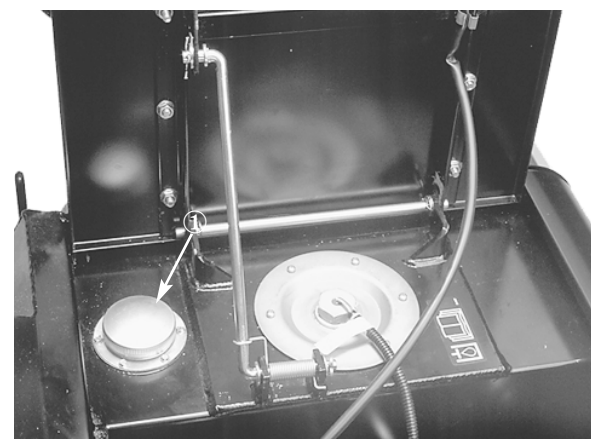

Figure 17

1. Seat support rod

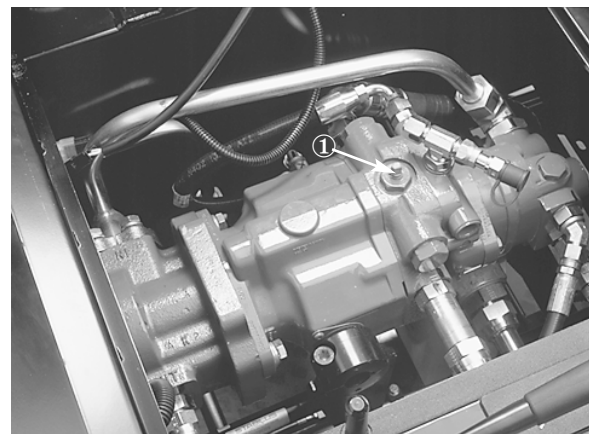

Figure 18

1. By-pass valve

OPERATING CHARACTERISTICS

Familiarization—Before mowing grass, practice in an open area. Start and stop the engine. Operate the machine in forward and reverse. Lower and raise the cutting units simultaneously and individually. Engage and disengage the reels. Operate with all cutting units down, then with only an individual cutting unit. When you feel familiar with the machine, practice operating around trees and obstacles. Also drive up and down slopes using both mowing and transport speeds.



WARNING

When operating the 4-wheel drive model, always use the seat belt and the roll over protection system..

Warning System—If a warning light comes on during operation, stop the machine immediately and correct the problem before continuing operation. Serious damage could occur if you operate the machine when it has a malfunction. *For short intervals*, however, you can use the emergency engine override button (Fig. 11) to operate the engine if it stops because of overheating.

Mowing—When you are at the area to be mowed, release the front cutting unit transport latch, center latch and outside latches. Lower the cutting units, engage the hand brake and stop the engine.

Cutting Unit Grass Deflectors—Adjust the grass deflectors to the horizontal position (Fig. 19), so grass clippings disperse backward; out and away from the cutting units. This will prevent clumps of grass clippings—especially wet grass clippings—dropping off the machine or cutting units, which affects the turf's appearance.

Note: Generally you can adjust the deflectors down slightly in dry grass and up slightly in wet grass.

While checking the speedometer, match the ground speed limiter (Fig. 20) and the reel speed control knob to the desired height-of-cut: refer to the cutting unit charts (Fig. 21). Use the decal at side of steering column as a guide only.

Start the engine and move the throttle to FAST so the engine runs at maximum speed. Move the Mow/Backlap lever to MOW (Fig. 11). The reels are now spinning. Disengage the hand brake. To move forward and cut grass, press the traction pedal forward (Fig. 20). Maintain traction pedal contact with the ground speed limiter to assure consistent grass clip and

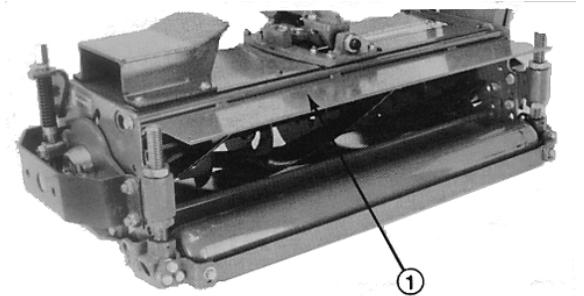

Figure 19

1. Grass deflector

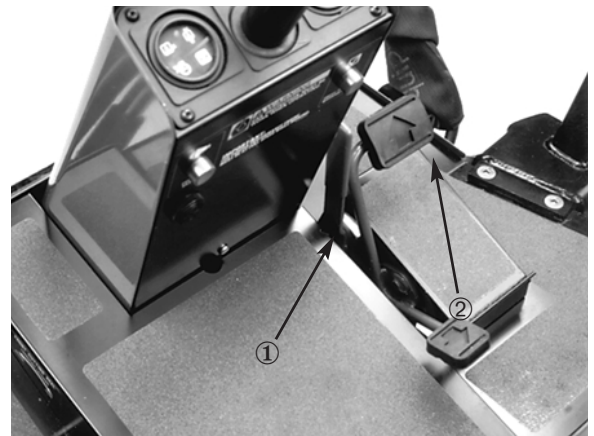

Figure 20

1. Ground speed limiter
2. Traction pedal

quality-of-cut.

Transport—When mowing is complete, move the MOW/BACKLAP lever to STOP. Raise the cutting units by pulling back on the lift control levers. Hold the levers back until the cutting units are raised fully (a squeal from the hydraulic system means the cutting units are fully raised). Lock the cutting units in place with the transport latches. When driving from one area to another, use a slower ground speed. Be careful when driving between objects so you do not accidentally damage the machine or the cutting units.



CAUTION

This product may exceed noise levels of 85 dB(A) at the operator position. Ear protectors are recommended for prolonged exposure to reduce the potential of permanent hearing damage.

Matching Ground Speed and Reel Speed—Vary the reel speed (while maintaining constant ground speed) to establish the best quality of cut for the area being mowed. Reel speeds either too fast or too slow for conditions may affect the quality of cut. Use the following cutting chart (Fig. 21) and the decal on steering console as a guide for initial adjustment of the ground and reel speeds.

Relate Height of cut and the ground speed to required reel speed setting on a 1 through 5 scale on the reel speed knob.

Note: 1 = 800 RPM; 2 = 900 RPM; 3 = 1000 RPM; 4 = 1,100 RPM and 5 = 1,200 RPM.

Recommended Reel Speed Settings

		5-Blade Reel					7-Blade Reel					11-Blade Reel				
		Speed km/h					Speed km/h					Speed km/h				
		5	6	8	10	11	5	6	8	10	11	5	6	8	10	11
Cut (mm)	25	1	3	5			2	5				1	3	5		
	31		1	3	5		1	3	5				1	3	4	
	38			2	3	3		1	3	5				1	2	4
	50				1	2			1	2	3				1	2
	63					1				1	2					
		31														

Figure 21

Maintenance

Minimum Recommended Maintenance Intervals

Maintenance Procedure	Maintenance Interval & Service																									
<table border="1"> <tr> <td>Lubricate reel control valve grease fitting</td> <td>Every 50 hours</td> <td>Every 100 hours</td> <td>Every 200 hours</td> <td>Every 400 hours</td> <td rowspan="4">Every 800 hours</td> </tr> <tr> <td>Lubricate reel speed valve with oil</td> <td></td> <td></td> <td></td> <td></td> </tr> <tr> <td>Lubricate all grease fittings</td> <td></td> <td></td> <td></td> <td></td> </tr> <tr> <td>Check batter condition & connections</td> <td></td> <td></td> <td></td> <td></td> </tr> </table>	Lubricate reel control valve grease fitting	Every 50 hours	Every 100 hours	Every 200 hours	Every 400 hours	Every 800 hours	Lubricate reel speed valve with oil					Lubricate all grease fittings					Check batter condition & connections									
Lubricate reel control valve grease fitting	Every 50 hours	Every 100 hours	Every 200 hours	Every 400 hours	Every 800 hours																					
Lubricate reel speed valve with oil																										
Lubricate all grease fittings																										
Check batter condition & connections																										
<ul style="list-style-type: none"> ‡ Change engine oil and filter Drain water from the hydraulic tank † Check engine fan and alternator belt Inspect cooling system hoses 																										
<ul style="list-style-type: none"> Inspect cutting unit reel drive belts †Torque wheel lug nuts 																										
<ul style="list-style-type: none"> Service the air cleaner Replace the fuel filter Inspect fuel lines and connections ‡ Torque cylinder head bolts ‡ Check engine rpm (idle and full throttle) 																										
<ul style="list-style-type: none"> Drain and clean the fuel tank ‡ Replace the hydraulic oil filter ‡ Adjust the valves Replace the hydraulic tank breather Change the front planetary gear lubricant Pack the rear wheel bearings †Replace transmission filter Check rear wheel toe-in 																										
<ul style="list-style-type: none"> † Initial break in at 10 hours ‡ Initial break in at 50 hours 																										
<ul style="list-style-type: none"> Replace moving hydraulic hoses Replace safety switches Flush the cooling system and replace fluid Change hydraulic oil 					<p>Annual Recommendations: Items are recommended every 1500 hours or two years, whichever occurs first.</p>																					

Check Daily:

- Check Interlock Switch Operation
- Check Parking Brake Operation
- Check Engine Oil Level
- Check Fuel level
- Check cooling system fluid level
- Drain the water/fuel separator
- Check the air restriction indicator
- Check the radiator, oil cooler and screen for debris
- Clean the traction pedal lockout
- Check for unusual engine noises
- Check for unusual operating noises
- Check the hydraulic system fluid level
- Check hydraulic hoses for damage
- Check for fluid leaks
- Check tire pressure
- Check instrument operation
- Check warning lam operation
- Check reel to mower knife adjustment
- Check height-of-cut adjustment
- Lubricate all grease fittings
- Touch-up damaged paint

LUBRICATION

Lubricate grease fittings after every 50 hours with No. 2 general purpose lithium-base grease. Also lubricate immediately after every washing.

Note: Remove the plastic caps over the fittings on the floating- or fixed-head kit pivots and replace them after greasing (Fig. 24).

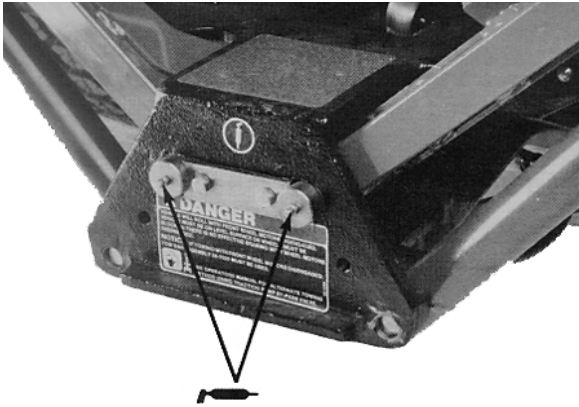

Figure 22
Lift Arms (5 fittings)

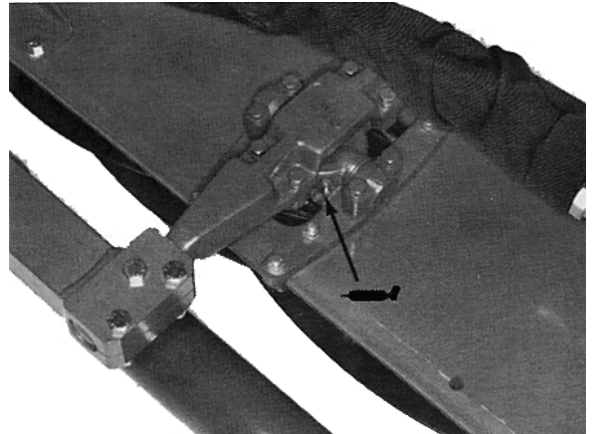

Figure 24
Floating or Fixed Head Kit Pivots
(Floating Head Kit Shown)

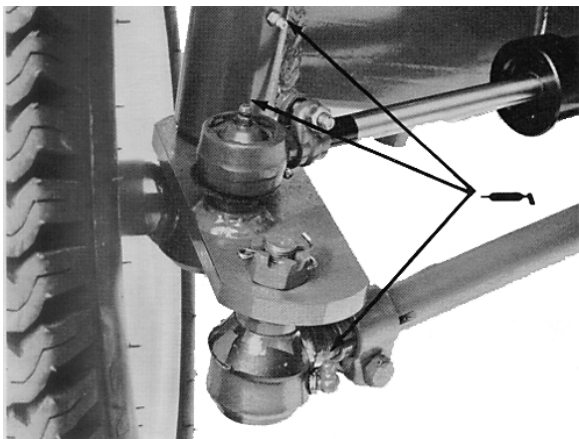

Figure 23
Rear Axle (3 fittings)

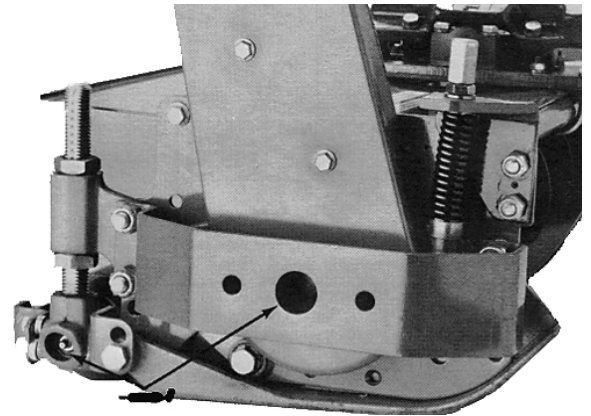

Figure 25
Reel & Roller Bearings

AIR CLEANER

1. Check the air cleaner housing for damage and replace if necessary.
2. Service air cleaner filters when the air cleaner indicator light illuminates and the warning signal sounds, or every 400 hours (more often in extreme dusty or dirty conditions).
3. Be sure the cover is sealing around the air cleaner body.

To Service:

1. Remove rear screen (Fig. 26).
2. Release the air cleaner cover latches, remove the cover and clean it.
3. Slide the primary filter out gently to minimize dust falling from it. **Do not remove the safety filter.**
4. If the primary filter is damaged, replace it. If just dirty, clean it with a solution of filter cleaner and water. Refer to directions on the filter cleaner carton.

IMPORTANT: Never try to clean a safety filter (located inside the primary filter). Replace the safety filter with a new one after every three primary filter cleanings.

5. Inspect the new filter for shipping damage. Check the sealing end of the filter. Do not install a damaged filter.
6. Insert the filter into the air cleaner body. Seal the filter by applying pressure to its outer rim. Do not press on the filter's flexible center.

ENGINE OIL AND FILTER

Change oil and filter after the first 50 hours of operation and every 100 hours thereafter.

FUEL SYSTEM

1. Drain and clean the fuel tank every 800 hours or yearly, whichever comes first.
2. Check fuel lines and connections every 400 hours or yearly, whichever comes first.



Figure 26

1. Rear screen
2. Knob

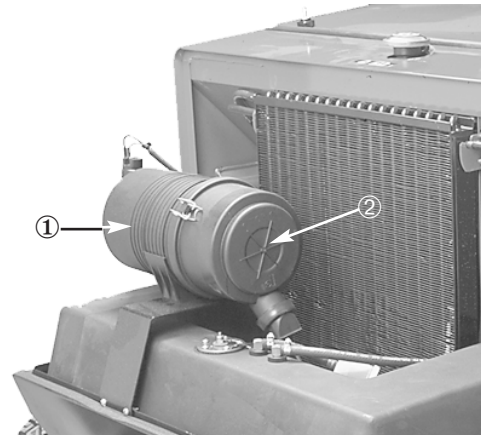

Figure 27

1. Air cleaner body
2. Air cleaner cover

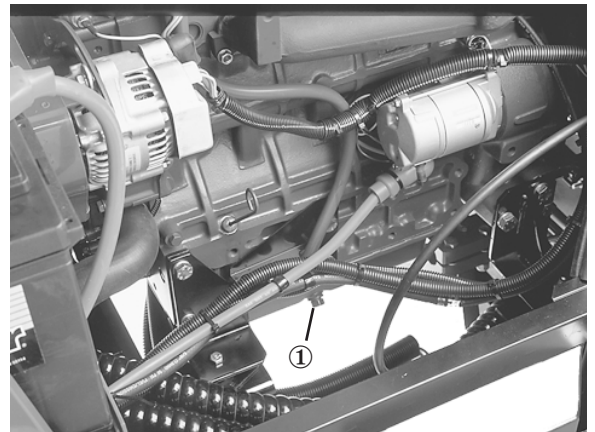

Figure 28

1. Drain plug

3. Drain water or other contaminants from the fuel filter daily.

DRAINING WATER FROM THE HYDRAULIC RESERVOIR

After every 100 operating hours, drain water from the hydraulic reservoir. Open the drain plug one-half turn and let fluid flow into a drain pan until water is not noticed in the hydraulic oil.

REAR WHEEL TOE-IN

1. Measure the center-to-center distance (at axle height) at the front and rear of the steering tires (Fig. 34). The front measurement must be 1/8 in. less than the rear measurement.
2. Loosen the clamps at both ends of the tie rods (Fig. 34).
3. Rotate the tie rod to move the front of the tire inward or outward.
4. Tighten the tie rod clamps when the adjustment is correct.

Note: Make sure the tie rod clamps are positioned so they do not interfere with the steering linkage.

CHECK THE PLANETARY GEAR DRIVE

To check the oil level, the oil should be at the bottom of the check/drain plug hold (Fig. 35) when the hole is placed in the 3 o'clock or 9 o'clock position. The traction unit must be on level ground when making this check.



Figure 29

1. Oil filter

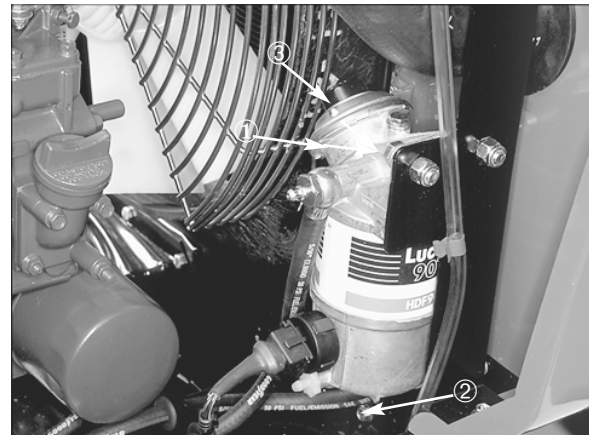

Figure 30

1. Fuel filter
2. Drain screw
3. Primer plunger

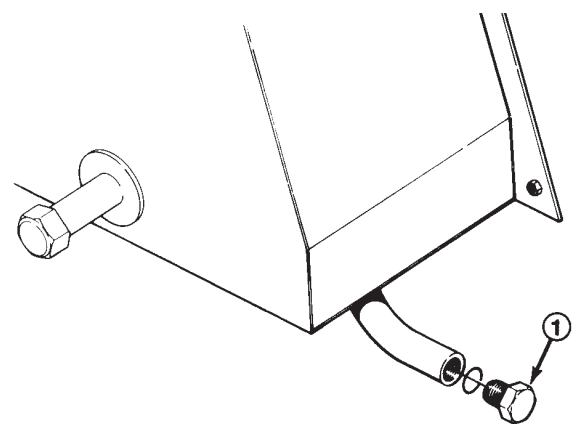

Figure 31

1. Drain plug



Figure 34

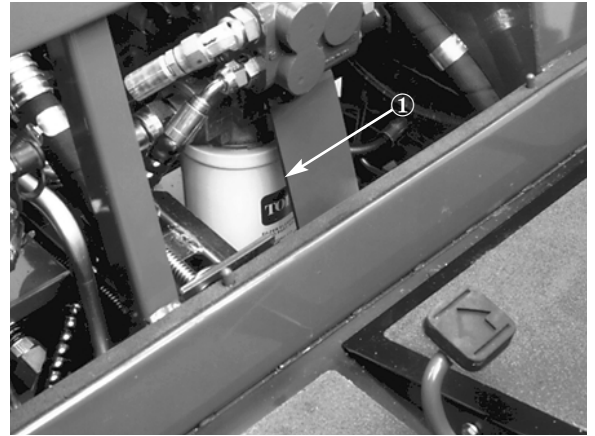

Figure 32

- 1. Hydraulic filter

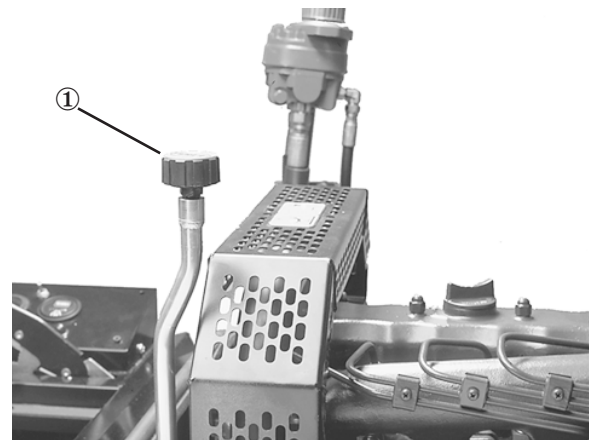

Figure 33

- 1. Breather



Figure 35

- 1. Check/Drain Plug