



Count on it.

Parts Catalog

20in Turf Seeder

Model No. 23508—Serial No. 40000000 and Up



Ordering Replacement Parts

To order replacement parts, please supply the part number, the quantity, and the description of each part desired.

Understanding Reference Numbers

Each identified part in an illustration has a reference number. The reference number for a part also appears in the parts list, along with other information about the part.

This catalog uses two special reference number formats, one to indicate parts in a service assembly and another to indicate the quantity of a given part in an illustration.

Service Assembly Reference Numbers

Parts in service assemblies have reference numbers in the form a:b. The a represents the reference number of the entire service assembly and the b represents a sequential number unique to each part within the service assembly.

For example, a wheel assembly might be identified by reference number 6, the tire by 6:1, the valve by 6:2, and the wheel by 6:3. When you order the assembly identified by reference number 6, you receive all parts identified by reference numbers 6:1, 6:2, and 6:3. However, you may also order any part individually. Reference numbers of this type appear in illustration and in parts lists.

Reference Numbers Indicating Quantity

In an illustration, if a reference number indicates more than one part, the reference number has the form nX y. The n represents the quantity of the part, the X is the multiplication symbol, and the y represents the reference number.

For example, in an illustration, the reference number 2X 37 means that two of the parts identified by reference number 37 are indicated.

Contents

Engine Assembly	4
Frame Assembly No. 121-6196.....	6
Handle Assembly	8
Cutting Wheel Assembly.....	10
Shaft Assembly No. 126-0034	12
Seed Gate Assembly	14
Belt Drive Assembly.....	16
Transmission Assembly	18
Transmission Assembly No. 121-1908.....	20

Engine Assembly

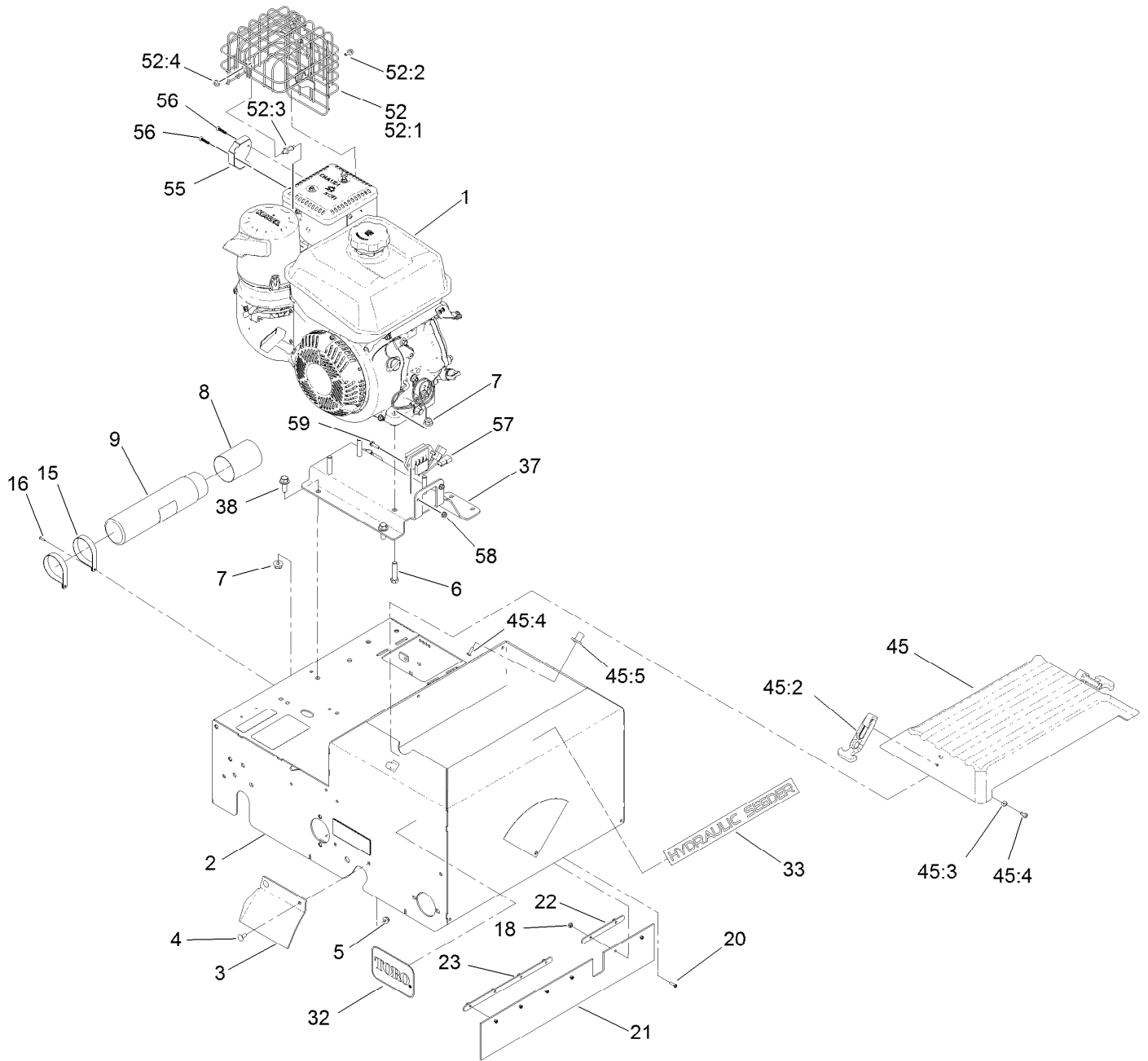

Engine Assembly (continued)

<i>Ref.</i>	<i>Part Number</i>	<i>Qty.</i>	<i>Description</i>	<i>Ref.</i>	<i>Part Number</i>	<i>Qty.</i>	<i>Description</i>
1		1	Engine-Kohler, Ch395●	37	135-0690-01	1	Plate-Engine
2	121-6196	1	Frame ASM	38	3234-42	3	Screw-HHF
3	121-1896-01	1	Guard-RH	45	126-1665	1	Seeder Cover Kit
4	3229-11	2	Screw-CARR	45:2	103-4080	2	Latch-Rubber
5	104-7201	2	Nut-HF	45:3	3256-14	4	Washer-Flat
6	323-9	4	Screw-HH	45:4	3290-500	6	Screw-PPH
7	104-8301	7	Nut-HF, NI	45:5	103-4081	2	Latch-Keeper
8	104-7048	1	Cap-Housing	52	135-3505	1	Guard-Muffler
9	104-7050	1	Tube-Manual	52:1	135-3932	1	Cage
15	2412-120	2	Clamp-R	52:2	135-3933	1	Bolt
16	3269-17	2	Rivet-Pop	52:3	135-3927	3	Stud
18	3296-1	6	Nut-Lock	52:4	135-3929	3	Nut
20	3290-392	6	Screw-SHH	55	135-3975	1	Deflector-Exhaust
21	121-1990	1	Guard-Dust	56	363-8572	2	Screw-PPH
22	121-1991	1	Plate-Retainer	57	135-3924	1	Regulator
23	121-1992	1	Plate-Retainer	58	32128-17	2	Nut-Lock, Flange
32	67-1300	2	Decal	59	32105-13	2	Screw-HWH
33	121-6177	1	Decal				

● Not serviced separately

Frame Assembly No. 121-6196

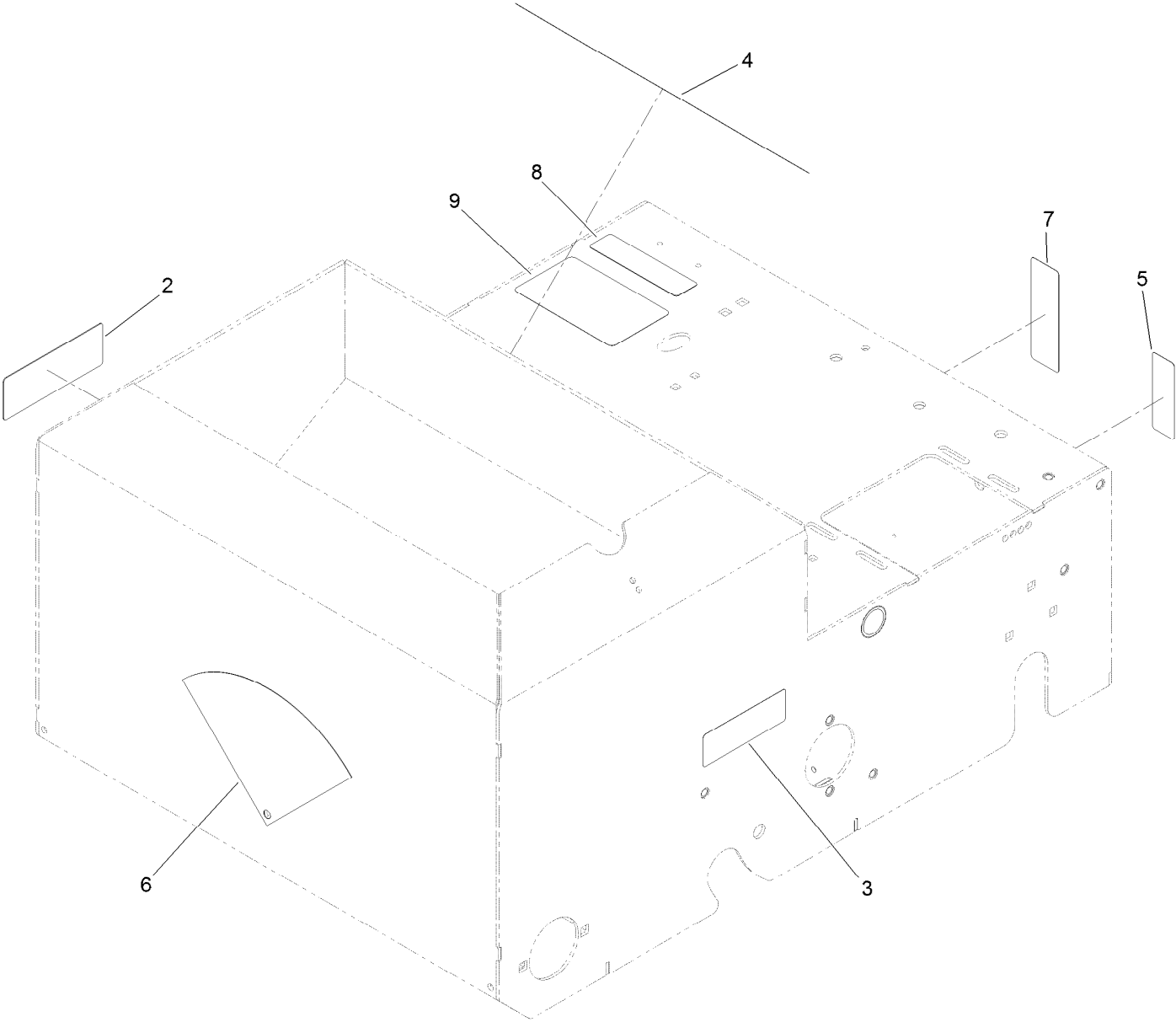

Frame Assembly No. 121-6196 (continued)

<i>Ref.</i>	<i>Part Number</i>	<i>Qty.</i>	<i>Description</i>
2	93-7321	1	Decal-Danger
3	117-4979	1	Decal-Warning
4	121-2011	1	Decal-Warning
5	115-9625	1	Decal-Brake, Parking

<i>Ref.</i>	<i>Part Number</i>	<i>Qty.</i>	<i>Description</i>
6	116-8535	1	Decal-Flow, Seed
7	121-6203	1	Decal-Bypass
8	117-2718	1	Decal-Arrester, Spark
9	126-0296	1	Decal-Aid, Service

Handle Assembly

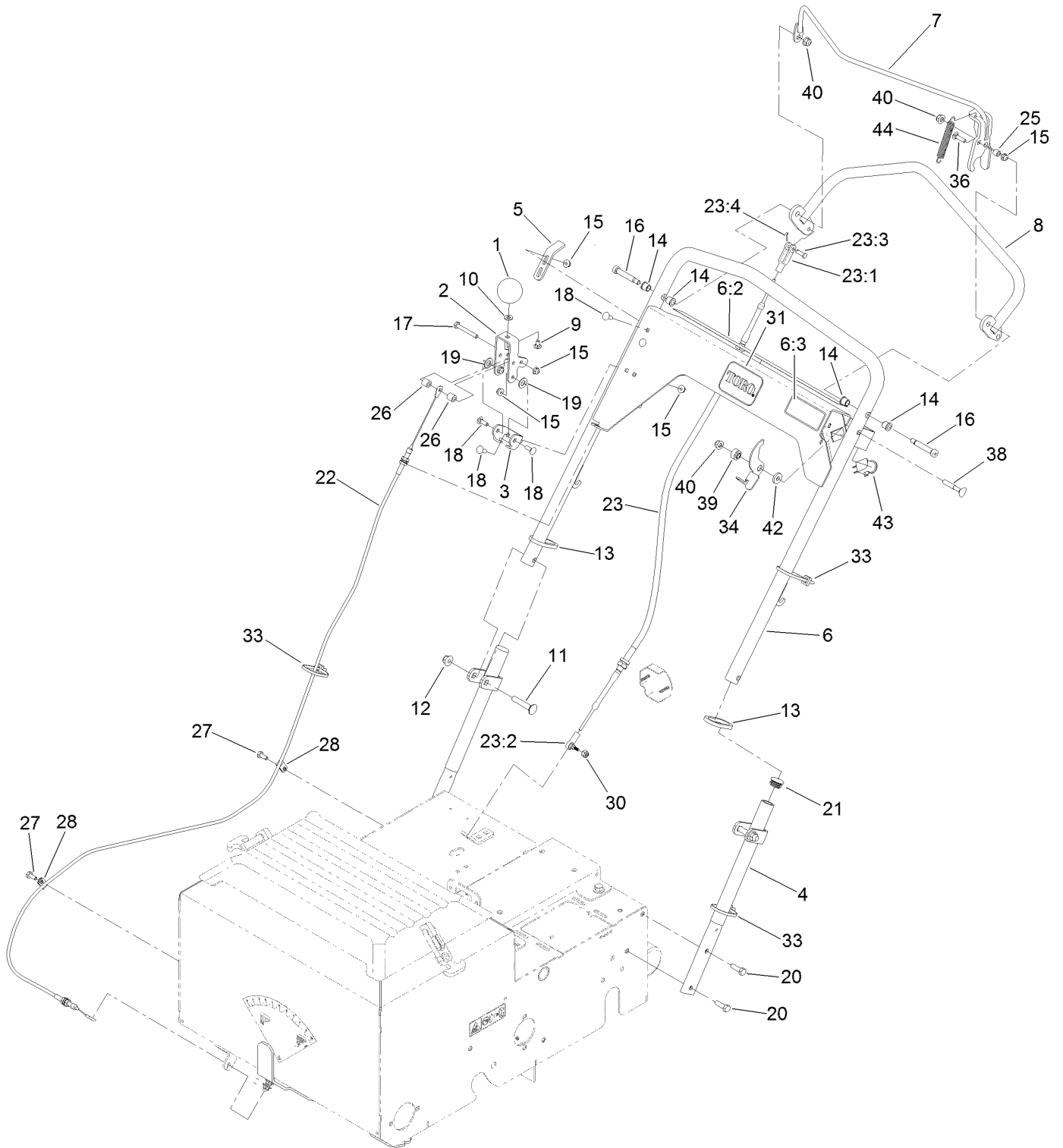

Handle Assembly (continued)

<i>Ref.</i>	<i>Part Number</i>	<i>Qty.</i>	<i>Description</i>	<i>Ref.</i>	<i>Part Number</i>	<i>Qty.</i>	<i>Description</i>
1	121-1877	1	Knob-Rate, Flow	21	121-4870	2	Plug
2	121-1878	1	Lever-Adjust, Flow	22	126-0042	1	Cable-Flow, Seed
3	121-1879	1	Bracket-Adjust, Flow	23	116-8252	1	Cable-Push Pull
4	121-1893-03	2	Handle-Lower	23:1	121-2000	1	Clevis
5	121-1928	1	Bracket-Adjust, Drive	23:2	117-9720	1	Ball Joint
6	116-9735	1	Handle	23:3	283-67	1	Pin-Clevis
6:2	116-8648	1	Decal-Control Panel, Seeder	23:4	3272-5	1	Pin-Cotter
6:3	116-8536	1	Decal-Safety Latch	25	66-8010	1	Spacer
7	126-0509-03	1	Bail-Clutch	26	22-7810	2	Spacer
8	121-1948-03	1	Handle-Drive	27	321-3	2	Screw-HH
9	3229-10	1	Screw-CARR ●	28	2412-149	2	Clamp-R
10	3256-22	1	Washer-Flat	30	3296-3	1	Nut-Lock
11	3231-6	2	Screw-CARR	31	70-2200	1	Decal
12	104-8301	2	Nut-HF, NI	33	3290-378	3	Tie-Cable
13	121-6202	2	Ring-Handle Lock	34	126-0205	1	Latch-Bail
14	103-9928	4	Bearing	36	3229-2	1	Screw-CARR
15	104-7201	8	Nut-HF	38	112-8876	1	Screw-Handle
16	126-0277	2	Screw-Shoulder	39	116-2690	1	Bushing-Stepped
17	321-11	1	Screw-HH	40	104-8300	3	Nut-HF, NI
18	3229-1	6	Bolt-CARR	42	88-7200	1	Washer-Flat
19	48-9220	2	Washer-Plain	43	82-2190	1	Switch-Bail
20	322-5	4	Screw-HH	44	95-3805	1	Spring

● Use Pro-Lock, Nut Type (P/N 1-840022, .5ml tube) on threads.

Cutting Wheel Assembly

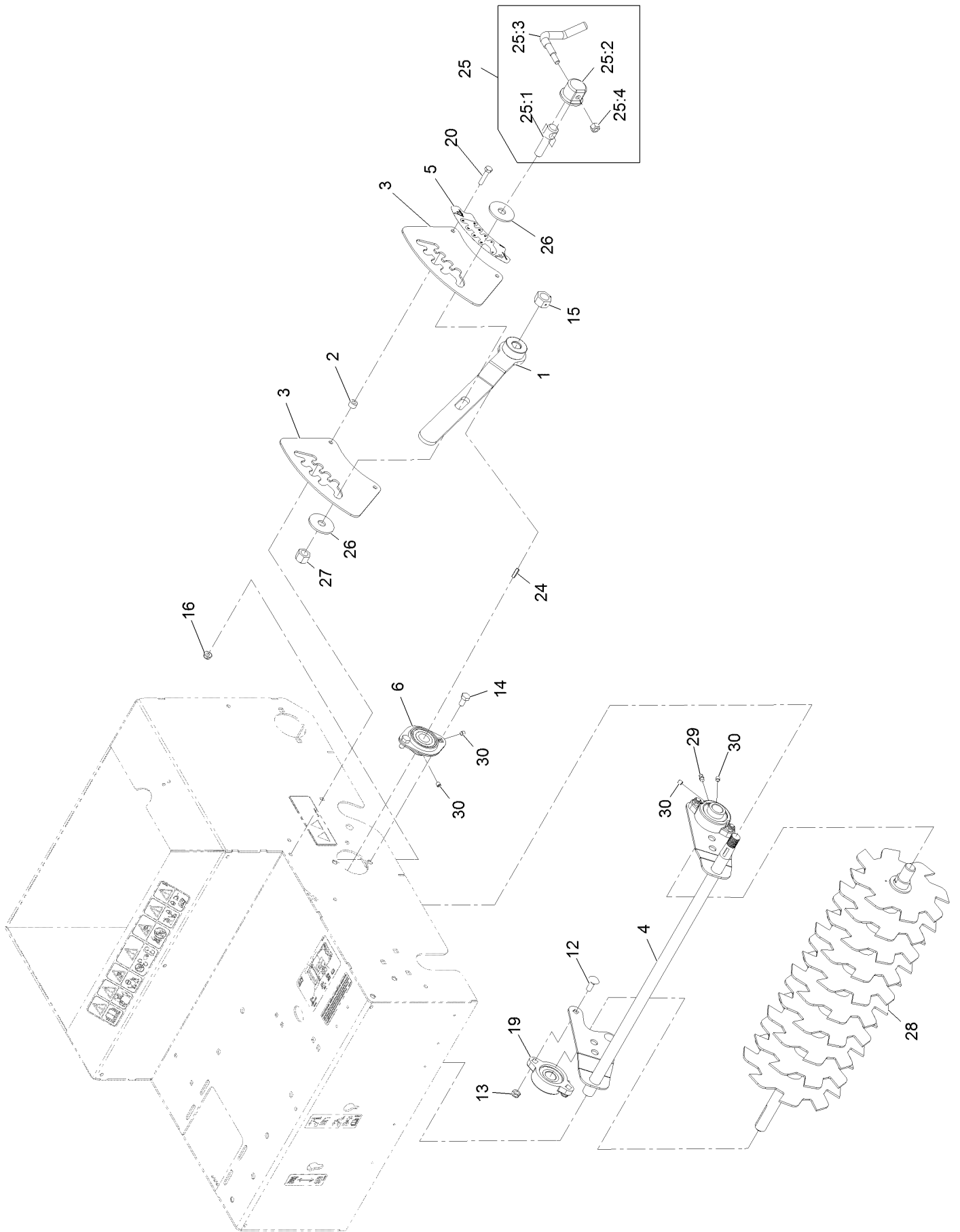

Cutting Wheel Assembly (continued)

<i>Ref.</i>	<i>Part Number</i>	<i>Qty.</i>	<i>Description</i>	<i>Ref.</i>	<i>Part Number</i>	<i>Qty.</i>	<i>Description</i>
1	116-9932-03	1	Handle-Height	20	321-8	2	Screw-HH
2	98-4799	2	Spacer	24	3257-5	1	Key-Woodruff
3	116-9928	2	Plate-Height	25	107-1664	1	Lever ASM
4	126-0010-03	1	Pivot-Height	25:1	106-3239	1	Screw-Lock
5	126-2446	1	Decal-Cut Depth, Slicer/Seeder	25:2	107-1644	1	Cap-Lock
6	121-1961	2	Bearing	25:3	106-3241	1	Lever-Lock
12	3230-16	4	Screw-CARR	25:4	3296-29	1	Nut-Lock, NI
13	3296-47	4	Nut-Lock, NI	26	86-1990	2	Washer-Thrust
14	322-2	4	Screw-HH	27	3296-23	1	Nut-Lock, NI
15	603164	1	Nut-Blade	28	126-0034	1	Slicer Shaft ASM
16	104-7201	2	Nut-HF	29	302-19	2	Fitting-Grease ●
19	116-9992	2	Bearing-Flange	30	3245-35	8	Screw-Set, HSH ●

● Use Pro-Lock, Nut Type (P/N 1-840022, .5ml tube) on threads.

Shaft Assembly No. 126-0034

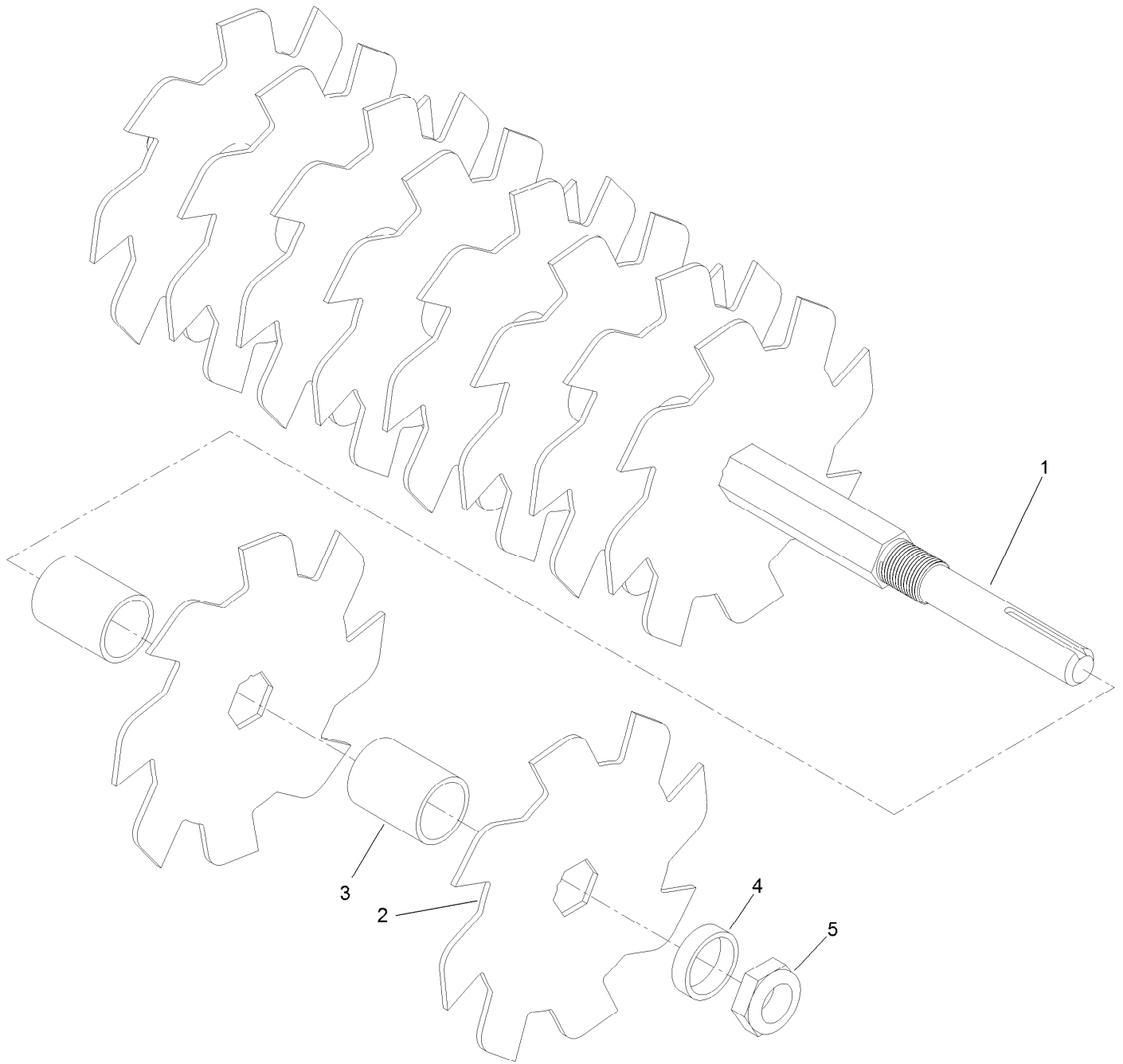

Shaft Assembly No. 126-0034 (continued)

<i>Ref.</i>	<i>Part Number</i>	<i>Qty.</i>	<i>Description</i>
1	126-0009	1	Shaft-Slicer
2	121-1931	10	Blade-Cutting, Seeder
3	126-0041	9	Spacer-Blade

<i>Ref.</i>	<i>Part Number</i>	<i>Qty.</i>	<i>Description</i>
4	126-0033	1	Spacer
5	3296-60	1	Nut-Lock, NI

Seed Gate Assembly

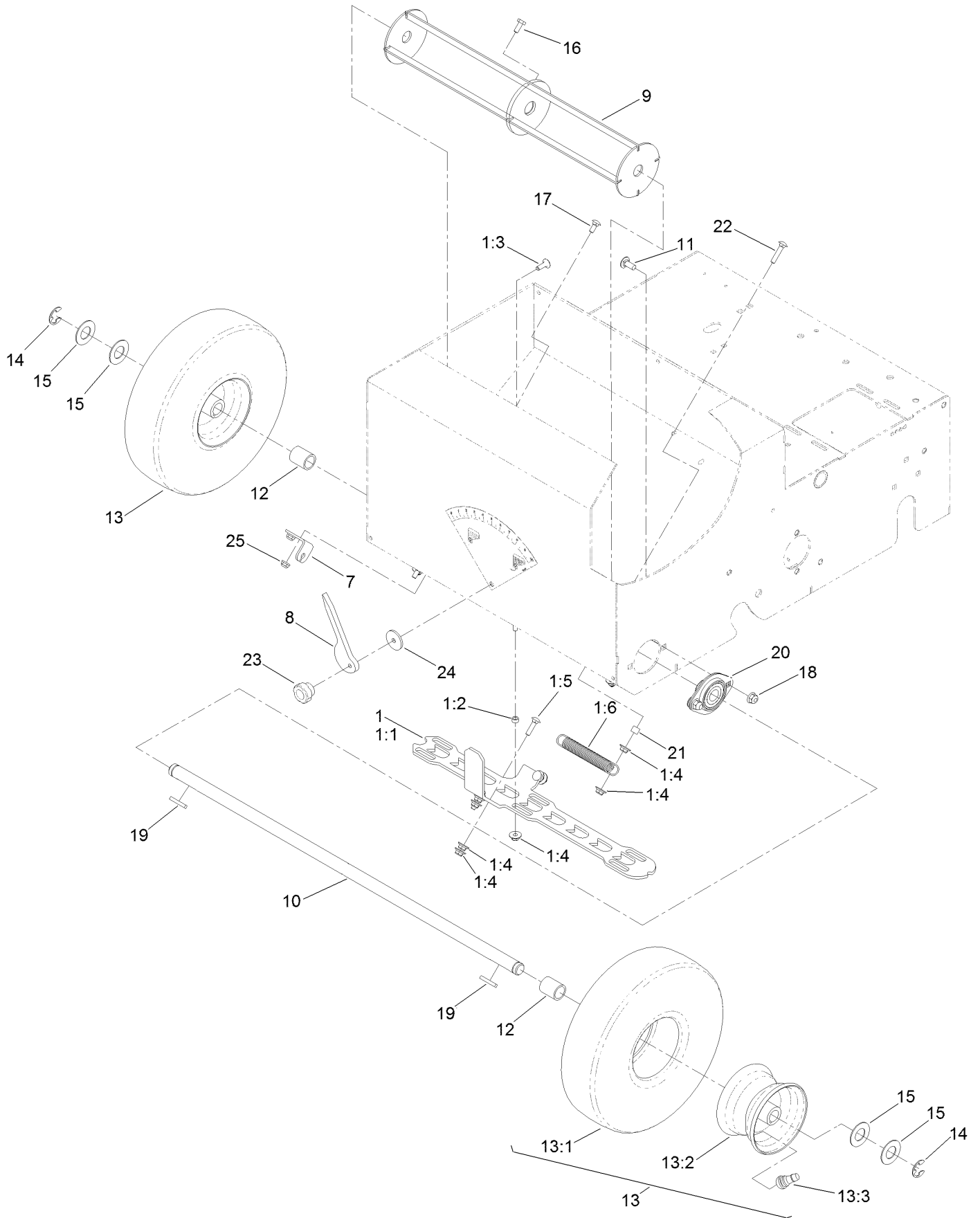

Seed Gate Assembly (continued)

<i>Ref.</i>	<i>Part Number</i>	<i>Qty.</i>	<i>Description</i>	<i>Ref.</i>	<i>Part Number</i>	<i>Qty.</i>	<i>Description</i>
1	126-0815	1	Seed Gate Kit	13:2	120-3706	1	Wheel-Rim
1:1	126-0415	1	Gate-Seed	13:3	5108	1	Valve
1:2	126-0416	6	Spacer	14	32151-48	2	E-Ring
1:3	1-807512	6	Bolt-CARR	15	3256-39	4	Washer-Flat
1:4	114-3778	12	Nut-HF	16	321-3	1	Screw-HH ●
1:5	3229-2	3	Screw-CARR	17	3229-11	2	Screw-CARR
1:6	121-2016	2	Spring-Extension	18	104-8300	4	Nut-HF, NI
7	121-1907	1	Bracket-Flow, Seed	19	92-0049	2	Key-Square
8	121-1912	1	Gauge-Flow, Seed	20	121-1961	2	Bearing
9	125-3782-03	1	Mixer	21	66-8010	2	Spacer
10	121-1929	1	Axle-Front ■	22	3229-3	2	Screw-CARR
11	3230-23	4	Screw-CARR	23	233-67	1	Knob-Chute
12	105-3838	2	Spacer	24	103995	1	Washer
13	120-3707	2	Wheel ASM	25	104-7201	2	Nut-HF
13:1	121-6081	1	Tire				

- Use Pro-Lock, Nut Type (P/N 1-840022, .5ml tube) on threads.
- Apply anti-seize compound to axle ends before installing tires.

Belt Drive Assembly

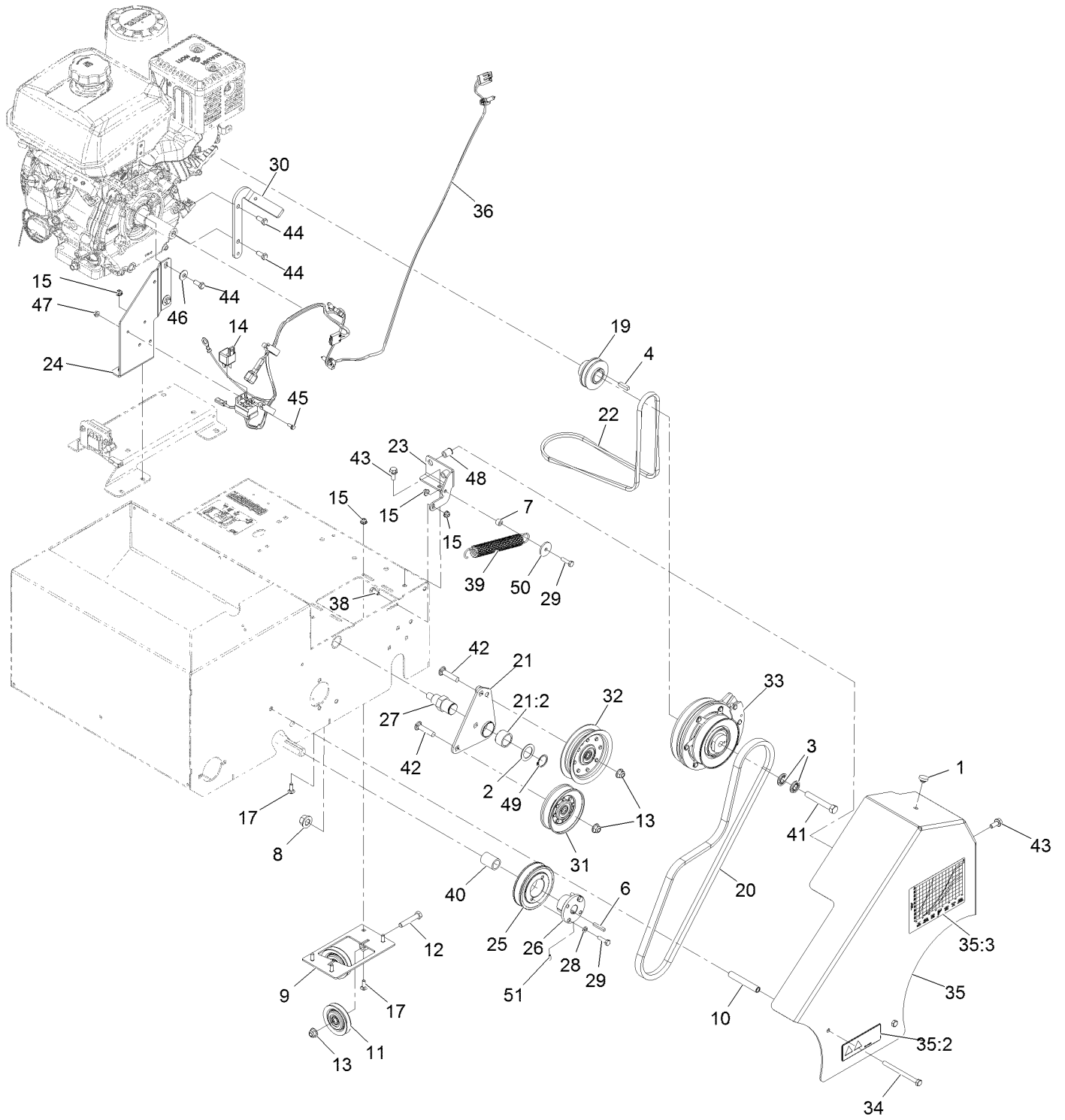

Belt Drive Assembly (continued)

<i>Ref.</i>	<i>Part Number</i>	<i>Qty.</i>	<i>Description</i>	<i>Ref.</i>	<i>Part Number</i>	<i>Qty.</i>	<i>Description</i>
1	1-513658	1	Bumper	28	3253-3	2	Washer-Lock
2	1-543436	1	Washer-Spacer	29	321-6	3	Screw-HH
3	1-603610	2	Washer-Spring	30	135-2030	1	Stop-Clutch
4	1-807259	1	Key	31	116-9623	1	Pulley-Idler V
6	92-0049	1	Key-Square	32	116-9728	1	Pulley-Idler Flat (4.06-Inch)
7	98-4799	1	Spacer	33	116-9852	1	Clutch-Electric
8	99-5107	1	Nut-Lock	34	322-19	2	Screw-HH
9	126-0418-03	1	Pulley-Tension	35	116-9925	1	Belt Guard ASM
10	104-0502	2	Spacer-Kickstand, Long	35:2	93-7321	1	Decal-Danger
11	121-1965	2	Pulley-Idler	35:3	116-8537	1	Decal-Graph, Seed
12	323-10	2	Screw-HH	36	135-3883	1	Harness-Wire
13	104-8301	4	Nut-HF, NI	38	321-3	1	Screw-HH
14	105-4145	1	Relay	39	126-0091	1	Spring-Extension
15	104-7201	7	Nut-HF	40	126-0108	1	Spacer
17	3229-1	6	Bolt-CARR	41	3212-12	1	Screw-HH ●
19	116-9471	1	Pulley-Mule Drive	42	3231-29	2	Screw-CARR
20	116-9518	1	Belt-Seeder, Clutch	43	3234-47	3	Screw-HHF
21	116-9519	1	Idler Arm ASM	44	3235-6	4	Screw-HH
21:2	116-9538	1	Bushing	45	3290-321	1	Screw-HWH
22	116-9532	1	Belt-Mule Drive	46	3290-456	2	Washer-Belleville
23	116-9533-01	1	Bracket-Spring	47	32128-17	2	Nut-Lock, Flange
24	135-2029-01	1	Guard-Belt	48	32148-7	2	Nut-Clinch
25	121-2019	1	Sheave-Taper Lock	49	32151-29	1	Ring-Retaining
26	121-2022	1	Bushing-Taper Lock	50	103995	1	Washer
27	116-9539	1	Pivot-Idler	51	126-0284	1	Screw-Set, Hs

● Use Pro-Lock, Nut Type (P/N 1-840022, .5ml tube) on threads.

Transmission Assembly

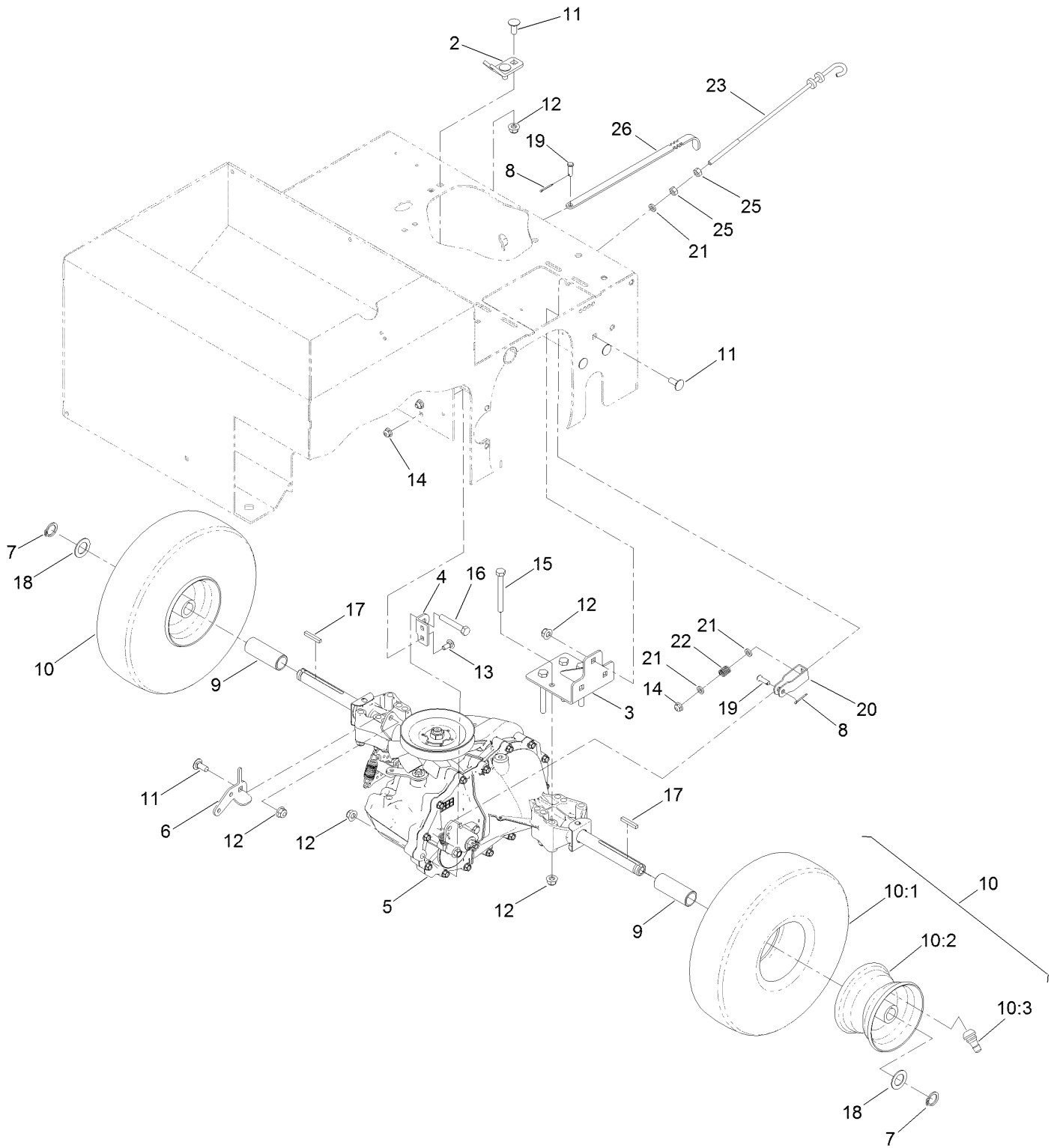

Transmission Assembly (continued)

<i>Ref.</i>	<i>Part Number</i>	<i>Qty.</i>	<i>Description</i>	<i>Ref.</i>	<i>Part Number</i>	<i>Qty.</i>	<i>Description</i>
2	121-1897	1	Bracket-Cable	13	3229-11	2	Screw-CARR
3	121-1901-03	2	Bracket-Axle	14	104-7201	3	Nut-HF
4	121-1904	1	Bracket-Transaxle, Torque	15	322-13	8	Screw-HH
5	121-1908	1	Transaxle ASM ●	16	322-10	1	Screw-HH
6	121-1909	1	Bracket-Transaxle	17	92-0049	2	Key-Square
7	32120-93	2	Ring-Retaining	18	67-9410	2	Washer
8	3272-4	2	Pin-Cotter	19	1-808265	2	Pin-Clevis
9	121-1988	2	Spacer	20	39-3080	1	Clevis
10	120-3707	2	Wheel ASM	21	55-9620	3	Spacer-Plate, Pivot
10:1	121-6081	1	Tire	22	63-4220	1	Spring-Compression
10:2	120-3706	1	Wheel-Rim	23	121-2018	1	Rod-Brake
10:3	5108	1	Valve	25	3217-5	2	Nut-Hex
11	3230-23	9	Screw-CARR	26	121-2039	1	Lever-Bypass
12	104-8300	18	Nut-HF, NI				

● Apply anti-seize compound to axle ends before installing tires.

Transmission Assembly No. 121-1908

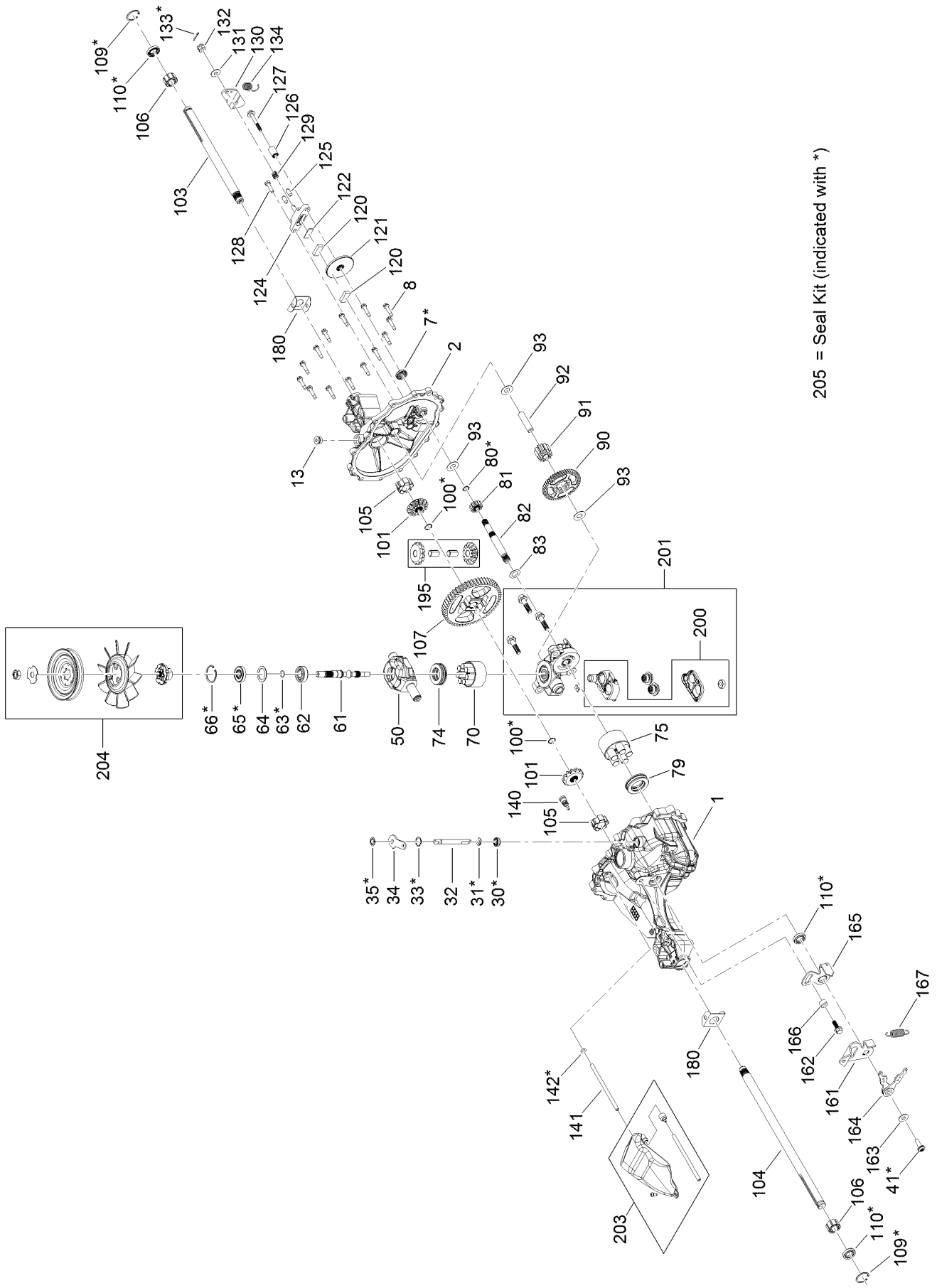

205 = Seal Kit (indicated with *)

Transmission Assembly No. 121-1908 (continued)

<i>Ref.</i>	<i>Part Number</i>	<i>Qty.</i>	<i>Description</i>	<i>Ref.</i>	<i>Part Number</i>	<i>Qty.</i>	<i>Description</i>
1	115-8313	1	Main Housing Kit	105	115-8314	2	Bushing-Inboard
2	119-5538	1	Housing Side Kit	106	115-8304	2	Bushing-Outboard
7	115-8335	1	Seal-Lip	107	115-8325	1	Gear-53T, Bull
8	117-5359	14	Screw-HHF	109	115-8303	2	Ring-Retaining, Internal
10	104-2147	1	Sealant ●	110	121-0970	3	Seal-Lip
13	104-2189	1	Plug-Thread, Straight	120	104-2171	2	Puck-Brake
30	106-8676	1	Seal-Lip	121	115-8337	1	Rotor-Brake
31	106-8677	1	Ring-Retaining, External	122	104-2181	1	Puck-Plate
32	115-8312	1	Rod-Bypass, Actuator	124	104-5343	1	Yoke-Brake
33	106-8679	1	Ring-Retaining, Internal	125	104-2176	2	Pin-Brake
34	115-8311	1	Arm-Bypass	126	104-2180	1	Spacer
35	106-8681	1	Ring-Retaining, External	127	104-5345	1	Screw-HF
41	107-2488	1	Screw	128	115-8339	1	Screw-HHCS
50	115-8319	1	Trunnion-Plate, Swash	129	104-2188	1	Spring-Brake, Anti Drag
61	115-8317	1	Shaft-Input	130	112-6195	1	Brake-Arm
62	94-1904	1	Bearing-Shaft, Ball	131	114-8491	1	Washer
63	119-5531	1	Ring-Retaining, Wire	132	119-5543	1	Nut-Castle
64	104-2104	1	Spacer	133	3272-7	1	Pin-Cotter
65	119-5532	1	Seal-Lip	134	104-2184	1	Spring-Arm, Brake (Bias)
66	119-5533	1	Ring-Retaining	140	104-5349	1	Fitting-SAE
70	121-0967	1	Piston Block ASM	141	115-8302	1	Hose
74	115-8320	1	Bearing-Thrust, Ball	142	104-5361	1	O-Ring
75	103-2666	1	Cylinder Block Kit	161	115-8308	1	Arm-Control, Return
79	94-6922	1	Bearing-Thrust	162	104-5312	1	Screw-HF
80	115-8331	1	Ring-Retaining, External	163	114-8491	1	Washer
81	119-5539	1	Gear-Pinion	164	115-8306	1	Bi Directional Return Kit
82	115-8329	1	Shaft-Motor	165	115-8310	1	Arm-Neutral
83	115-8328	1	Washer	166	115-8309	1	Bushing
90	119-5540	1	Gear	167	115-8307	1	Spring-Extension
91	115-8333	1	Gear-Jackshaft, 11T	180	119-5527	2	Spring Clip-Housing Thrust
92	115-8334	1	Pin-Jackshaft	195	137-0656	1	Miter Gears W/Pins Kit
93	94-1933	3	Washer	200	115-8323	1	Filter Kit
100	104-5328	2	Ring-Retaining, Spiral	201	137-0657	1	Centersection W/Filter Kit
101	115-8315	2	Gear-Bevel, 12T (Spline, ID)	203	115-8301	1	Expansion Tank Kit
103	121-0968	1	Shaft-Axle, Keyed	204	137-0658	1	Fan/Pulley Kit
104	121-0969	1	Shaft-Axle, Keyed	205	115-8316	1	Seal Kit

● Not illustrated

Notes:

Notes:



Count on it.