



Count on it.

Operator's Manual

**PowerPlex™ 14in 40V MAX
Chainsaw**

Model No. 51880—Serial No. 318000001 and Up

Model No. 51880T—Serial No. 318000001 and Up

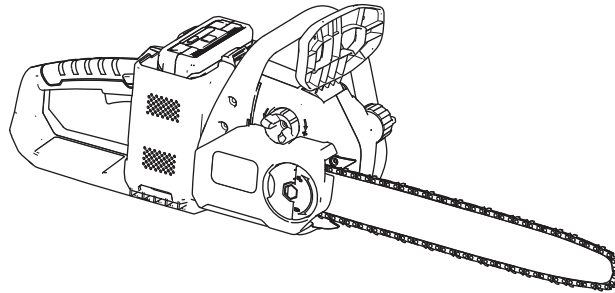

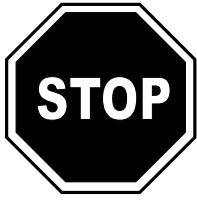

If you have questions or problems, call toll free 1-855-340-7689 before returning this product.

⚠ WARNING

CALIFORNIA Proposition 65 Warning

This product contains a chemical or chemicals known to the State of California to cause cancer, birth defects, or reproductive harm.

Introduction

This chain saw is designed for cutting tree branches, logs, and wooden beams of a diameter no longer than the cutting length of the guide bar. It is to be used only by adults. It is designed to use only battery pack Model 88540 (provided with Model 51880) or Model 88541.

Read this information carefully to learn how to operate and maintain your product properly and to avoid injury and product damage. You are responsible for operating the product properly and safely.

You may contact Toro directly at www.Toro.com for product and accessory information, help finding a dealer, complete warranty details, or to register your product.

Model 51880T does not include a battery pack or a charger.

Safety

When using electric power tools, basic safety precautions should always be followed to reduce the risk of fire, electric shock, and personal injury, including the following:

⚠ WARNING

Failure to follow all warnings and instructions may result in electric shock, fire and/or serious personal injury.

Read all safety warnings and all instructions.

Save all warnings and instructions for future reference.

The term “power tool” in all the warnings refers to your corded power tool or battery-operated (cordless) power tool.

1. Work area safety

- A. **Keep work area clean and well lit.** *Cluttered or dark areas invite accidents.*
- B. **Do not operate power tools in explosive atmospheres, such as in the presence of flammable liquids, gasses, or dust.** *Power tools create sparks, which may ignite the dust or fumes.*
- C. **Keep children and bystanders away while operating a power tool.** *Distractions can cause you to lose control.*

2. Personal safety

- A. **Stay alert, watch what you are doing, and use common sense when operating a power tool. Do not use a power tool while you are tired or under the influence of drugs, alcohol, or medication.** *A moment of inattention while operating power tools could result in serious personal injury.*
- B. **Use personal protective equipment. Always wear eye protection.** *Protective equipment such as a dust mask, non-skid safety shoes, hard hat, or hearing protection used for appropriate conditions reduces personal injuries.*
- C. **Prevent unintentional starting. Ensure that the switch is in the OFF position before you connect the tool to a power source and/or battery pack, pick it up, or carry it.** *Carrying power tools with your finger on the switch or energizing power tools that have the switch on invites accidents.*
- D. **Remove any adjusting key or wrench before turning the power tool on.** *A*

wrench or a key left attached to the power tool may result in personal injury.

- E. **Do not overreach. Keep proper footing and balance at all times.** *This enables better control of the power tool in unexpected situations.*
 - F. **Dress properly. Do not wear loose clothing or jewelry. Tie back and keep your hair, clothing, and gloves away from moving parts.** *Loose clothes, jewelry, or long hair can get caught in moving parts.*
 - G. **If devices are provided for the dust extraction and collection, ensure that these are connected and properly used.** *Using these devices can reduce dust-related hazards.*
 - H. **Keep your hands and feet away from the cutting area.**
3. **Power tool use and care**
- A. **Do not force the power tool. Use the correct power tool for your application.** *The correct power tool will do the job better and safer at the rate for which it was designed.*
 - B. **Do not use the power tool if the switch does not turn it on and off.** *Any power tool that cannot be controlled with the switch is dangerous and must be repaired.*
 - C. **Disconnect the plug from the power source and/or the battery pack from the power tool before adjusting it, changing accessories on it, or storing it.** *Such preventive safety measures reduce the risk of starting the power tool accidentally.*
 - D. **Store idle power tools out of the reach of children, and do not allow persons unfamiliar with the power tool or these instructions to operate the power tool.** *Power tools are dangerous in the hands of untrained users.*
 - E. **Store idle appliances indoors.** *When not in use, appliances should be stored indoors in a dry and high or locked-up place, out of the reach of children.*
 - F. **Maintain power tools. Check for misalignment or binding of moving parts, broken parts, and any other condition that may affect the operation of the power tools. If damaged, have the power tool repaired before use.** *Many accidents are caused by poorly maintained power tools.*
 - G. **Keep cutting tools sharp and clean.** *Properly maintained cutting tools with sharp*

cutting edges are less likely to bind and are easier to control.

- H. **Use the power tool, accessories, tool bits, etc. in accordance with these instructions and in the manner intended for the particular type of power tool, taking into account the working conditions and the work to be performed.** *Using the power tool for operations different from those intended could result in a hazardous situation.*
 - I. **Keep guards in place and in working order.**
 - J. **Use only replacement guide bars and chains specified by the manufacturer.** *Incorrect replacement guide bars and chains may cause chain breakage and/or kickback.*
 - K. **Follow the manufacturer's sharpening and maintenance instructions for the saw chain.** *Decreasing the depth gauge height can lead to increased kickback.*
4. **Chain Saw Safety**
- A. **Hold the power tool by insulated gripping surfaces only, because the saw chain may contact hidden wiring or its own cord.** *Saw chains contacting a live wire may make exposed metal parts of the power tool live and could give you an electric shock.*
 - B. **Wear safety glasses, hearing protection, and protective equipment for your head, hands, legs, and feet.** *Wearing adequate protective clothing reduces personal injury by flying debris or accidental contact with the saw chain.*
 - C. **Cutting trees can be hazardous and requires expertise.** *Do not use the chain saw to fell large trees that have a diameter greater than the length of the guide bar.*
 - D. **Do not operate a chain saw in a tree.** *Operating a chain saw while up in a tree may result in personal injury.*
 - E. **Always keep proper footing and operate the chain saw only when standing on a fixed, secure, and level surface.** *Slippery or unstable surfaces such as ladders may cause a loss of balance or control of the chain saw.*
 - F. **When cutting a limb that is under tension, be alert for spring back.** *When the tension in the wood fiber is released, the spring loaded limb may strike you and/or throw the chain saw out of control.*

- G. **Use extreme caution when cutting brush and saplings.** *The slender material may catch the saw chain and be whipped toward you or pull you off balance.*
 - H. **Carry the chain saw by the front handle with the chain saw switched off and away from your body. When transporting or storing the chain saw, always use the guide bar cover.** *Proper handling of the chain saw reduces the likelihood of accidental contact with the moving saw chain.*
 - I. **Follow the instructions for lubricating, chain tensioning, and changing accessories.** *Improperly tensioned or lubricated chain may either break or increase the chance for kickback.*
 - J. **Keep handles dry, clean, and free from oil and grease.** *Greasy, oily handles are slippery, causing loss of control.*
 - K. **Avoid kickback.** *Kickback may occur when the nose or tip of the guide bar touches an object, or when the wood pinches the saw chain while you are cutting. Tip contact may cause a sudden reverse reaction, kicking the guide bar up and back toward you; pinching the saw chain along the top of the guide bar may push the guide bar rapidly back toward you. Either of these reactions may cause you to lose control of the saw, which could result in a serious personal injury. You can avoid kickback by taking proper precautions as given below:*
 - **Use both hands whenever you operate the chain saw. Maintain a firm grip, with thumbs and fingers encircling the chain saw handles, with both hands on the saw, and with your body and arm in position that allows you to resist kickback forces.** *You can control kickback forces if proper precautions are taken. Do not let go of the chain saw!*
 - **Do not overreach and do not cut above shoulder height.** *This helps prevent unintended tip contact and enables better control of the chain saw in unexpected situations.*
- A. *Do not charge the power tool in rain or in wet locations.*
 - B. *Do not use a battery-operated power tool in the rain.*
 - C. *Use only the following type and size of battery(ies): Toro battery Model 88540 or 88541 and battery charger Model 88542.*
 - D. *Remove or disconnect the battery before servicing, cleaning, or removing material from the power tool.*
 - E. *Do not dispose of the battery in a fire; the cell may explode. Check with local codes for possible special disposal instructions.*
 - F. *Do not open or mutilate the battery. Released electrolyte is corrosive and may cause damage to the eyes or skin. It may be toxic if swallowed.*
 - G. *Do not open or mutilate the battery. Released electrolyte is flammable and can cause damage if exposed to fire.*
 - H. *Exercise care in handling batteries to prevent shorting the battery with conducting materials such as rings, bracelets, and keys. The battery or conductor may overheat and cause burns.*
 - I. *Charging time increases if the battery pack is not charged within the appropriate temperature range.*

SAVE THESE INSTRUCTIONS

5. Service

Have your power tool serviced by a qualified repair person using only identical replacement parts. *This ensures that the safety of the power tool is maintained.*

6. Battery Safety

Safety and Instructional Decals



Safety decals and instructions are easily visible to the operator and are located near any area of potential danger. Replace any decal that is damaged or missing.

WARNING TO REDUCE THE RISK OF INJURY, USER MUST READ INSTRUCTION MANUAL. Do not expose to rain. Use only TORO PowerPlex battery. Contact of the guide bar tip with any object should be avoided. Tip contact can cause the guide bar to move suddenly upward and backward, which can cause serious injury. Always use two hands when operating the chain saw.

AVERTISSEMENT POUR RÉDUIRE LES RISQUES DE BLESSURES, LISEZ ATTENTIVEMENT LE MANUEL DE L'UTILISATEUR. Ne l'exposez pas à la pluie. Utilisez uniquement avec batterie TORO PowerPlex. Évitez tout contact de l'avant de la barre de guidage avec des objets. Ce contact peut faire remonter brusquement la barre de guidage et la repousser en arrière, et causer de graves blessures. Tenez toujours la tronçonneuse à deux mains lorsque vous l'utilisez.

BAR LENGTH: 14in / LONGUEUR DU GUIDE-CHAÎNE: 350mm
 BAR / BARRE: 88580 SAW CHAIN / TRONÇONNEUSE : 88581
 40V MAX* DC CLASS 2C / CLASSE 2C

PATENT: www.ttcopats.com
 THE TORO COMPANY
 8111 Lyndale Avenue South
 Bloomington, MN 55420-1196 USA

*Battery manufacturer rating = 40V maximum & 36V rated. Actual voltage varies with load.
 Country of Origin: PRC
 Pays d'origine: PRC

Model: 51880
 Modèle: [REDACTED]

Serial Number: [REDACTED]
 Numéro de série: [REDACTED]

Date Code: [REDACTED]
 Code de date: [REDACTED]

Conforms to UL STD 60745-1 & 60745-2-13
 Certified to CSA
 Intertek
 STD 60745-1 & 60745-2-13 3131666

136-2469

decal136-2469

WARNING TO REDUCE THE RISK OF INJURY, USER MUST READ INSTRUCTION MANUAL. Do not expose to rain. Use only TORO PowerPlex battery. Contact of the guide bar tip with any object should be avoided. Tip contact can cause the guide bar to move suddenly upward and backward, which can cause serious injury. Always use two hands when operating the chain saw.

AVERTISSEMENT POUR RÉDUIRE LES RISQUES DE BLESSURES, LISEZ ATTENTIVEMENT LE MANUEL DE L'UTILISATEUR. Ne l'exposez pas à la pluie. Utilisez uniquement avec batterie TORO PowerPlex. Évitez tout contact de l'avant de la barre de guidage avec des objets. Ce contact peut faire remonter brusquement la barre de guidage et la repousser en arrière, et causer de graves blessures. Tenez toujours la tronçonneuse à deux mains lorsque vous l'utilisez.

BAR LENGTH: 14in / LONGUEUR DU GUIDE-CHAÎNE: 350mm
 BAR / BARRE: 88580 SAW CHAIN / TRONÇONNEUSE : 88581
 40V MAX* DC CLASS 2C / CLASSE 2C

PATENT: www.ttcopats.com
 THE TORO COMPANY
 8111 Lyndale Avenue South
 Bloomington, MN 55420-1196 USA

*Battery manufacturer rating = 40V maximum & 36V rated. Actual voltage varies with load.
 Country of Origin: PRC
 Pays d'origine: PRC

Model: 51880T
 Modèle: [REDACTED]

Serial Number: [REDACTED]
 Numéro de série: [REDACTED]

Date Code: [REDACTED]
 Code de date: [REDACTED]

Conforms to UL STD 60745-1 & 60745-2-13
 Certified to CSA
 Intertek
 STD 60745-1 & 60745-2-13 3131666

136-2470

decal136-2470

TORO

LITHIUM-ION BATTERY CHARGER
 CHARGEUR DE BATTERIE LITHIUM-ION
 Input: 100-120V AC 50/60Hz Max 3.0A
 Output: 41.8V MAX* DC 2.5A

*Battery manufacturer rating = 40V maximum & 36V nominal. Actual voltage varies with load.
 *Tension indiquée par le fabricant de la batterie = 40 V max., 36 V nominale. La tension réelle varie en fonction de la charge.

Backfeed Protection / Protection contre le retour d'énergie

CAUTION To reduce the risk of injury, user must read the instruction manual. Charge only TORO PowerPlex type rechargeable battery. Other types of batteries may burst causing personal injury and damage. Risk of electric shock. Do not expose to liquid, vapor, or rain. Do not interconnect output terminal. For indoor use only.

ATTENTION Pour réduire le risque de blessures, l'utilisateur doit lire le manuel d'utilisation. Utilisez uniquement pour les batteries rechargeables type TORO PowerPlex. D'autres types de batteries pourraient exploser et causer des blessures ou des dommages. Risque de décharge électrique. Ne pas exposer à des liquides, à la vapeur ou à la pluie. Ne pas interconnecter la borne de sortie. Pour usage intérieur uniquement.

Country of Origin: PRC / Pays d'origine: PRC

THE TORO COMPANY
 8111 Lyndale Avenue South
 Bloomington, MN 55420-1196 USA
 PATENT: www.ttcopats.com

Model: 88542 SL
 Modèle: [REDACTED]

Serial Number: [REDACTED]
 Numéro de série: [REDACTED]

Date Code: [REDACTED]
 Code de date: [REDACTED]

Conforms to UL STD 1012
 Certified to CSA
 STD C22.2 No. 107.2-91
 Intertek
 3131666

136-2473

decal136-2473

WARNING To reduce the risk of injury, user must read the instruction manual. Use only with TORO PowerPlex battery charger. Wear eye protection. Do not short terminals. Do not throw into fire. Risk of fire, explosion and burns. Do not disassemble, crush, expose to heat or incinerate. Keep battery out of reach of children. To reduce risk of injury to persons, remove battery pack when not in use.

AVERTISSEMENT Pour réduire le risque de blessures, l'utilisateur doit lire le manuel d'utilisation. Utilisez uniquement avec chargeur de batterie TORO PowerPlex. Portez des lunettes de protection. Ne pas court-circuiter. Ne jetez pas au feu. Risque d'incendie, d'explosion et des brûlures. Ne pas démonter, écraser, exposer à une température au-dessus de 100°C. Conservez la batterie hors de portée des enfants. Pour réduire les risques de blessures corporelles, retirez l'ensemble batterie quand la machine ne sert pas.

TORO 40V MAX* DC 90 Wh
 Li-Ion Battery / Batterie au Lithium-ion

*Battery manufacturer rating = 40V maximum & 36V nominal. Actual voltage varies with load.
 *Tension indiquée par le fabricant de la batterie = 40 V max., 36 V nominale. La tension réelle varie en fonction de la charge.

THE TORO COMPANY
 8111 Lyndale Avenue South
 Bloomington, MN 55420-1196 USA
 PATENT: www.ttcopats.com

Model: 88540
 Modèle: [REDACTED]

Serial Number: [REDACTED]
 Numéro de série: [REDACTED]

Date Code: [REDACTED]
 Code de date: [REDACTED]

136-2471

Model 88540

decal136-2471



136-2475

decal136-2475

1. Read the *Operator's Manual*; wear hearing and eye protection; do not contact objects with the guide bar tip; tip contact can cause serious personal injury; always use 2 hands when operating the chain saw.

POWERPLEX™ 40V^{MAX} LITHIUM

CHARGING PROCEDURE (LED INDICATOR) / PROCEDURE DE CHARGEMENT (VOYANT DEL)
 DO NOT REMOVE THIS DECAL / NE PAS RETIRER CET AUTOCOLLANT

1 [REDACTED] 2 100% 3 [REDACTED] 4 [REDACTED]

136-2476

decal136-2476

1. The battery pack is charging.
2. The battery pack is fully charged.
3. The battery pack is too warm.
4. Replace the battery pack.

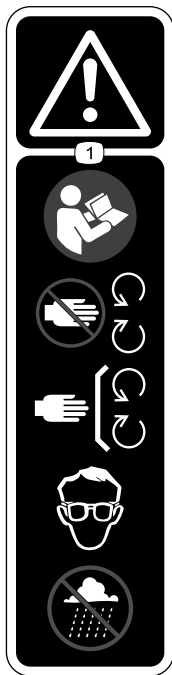

136-2533

decal136-2533

1. Warning—read the *Operator's Manual*; keep away from moving parts; keep all guards and covers in place; wear eye protection; do not operate in wet conditions.

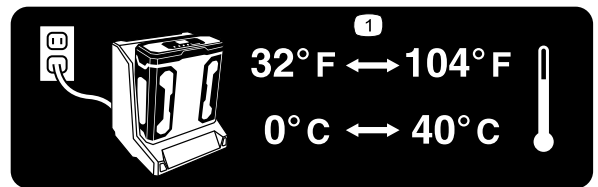

136-2539

decal136-2539

1. Charge the battery where the temperature is between 0°C and 40°C (32°F and 104°F).

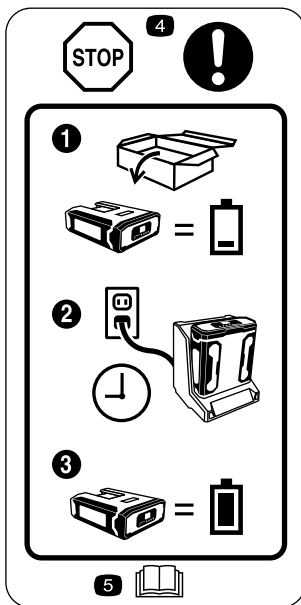

136-2534

decal136-2534

1. The battery does not come out of the box fully charged.
2. Place the battery in the battery charger.
3. Wait until the battery is fully charged before the first use.
4. Stop—follow these instructions before first use.
5. Read the *Operator's Manual*.

Setup

Note: The battery pack is not fully charged when you purchase it. Before using the tool for the first time, refer to [Charging the Battery Pack](#) (page 14).

Filling the Chain Saw with Bar and Chain Oil

Important: Use only bar and chain oil (sold separately).

1. Place the chain saw on a level surface.
2. Clean the area around the oil cap ([Figure 1](#)).

Note: Make sure that you do not allow debris/wood chips to enter the oil tank.

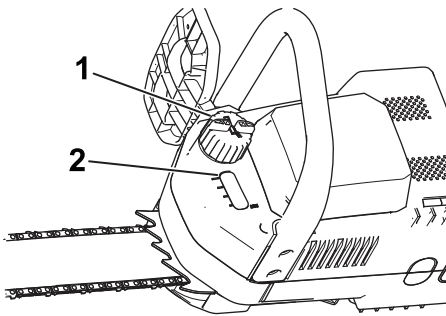

Figure 1

g192110

1. Oil cap
2. Oil window

3. Remove the cap and pour oil into the chain saw until the oil fills the window ([Figure 1](#)).

Do not fill the chain saw higher than the bottom of the fill neck.

4. Clean up any spilled oil and replace the oil cap.

Mounting the Battery Charger (Optional)

If desired, mount the battery charger securely on a wall using the wall-mount key holes on the back of the charger.

Mount it indoors (such as a garage or other dry place), near a power outlet, and out of the reach of children.

Refer to [Figure 2](#) for assistance in mounting the charger.

Note: Slide and twist the charger over the appropriately positioned hardware to secure the charger in place (hardware not included).

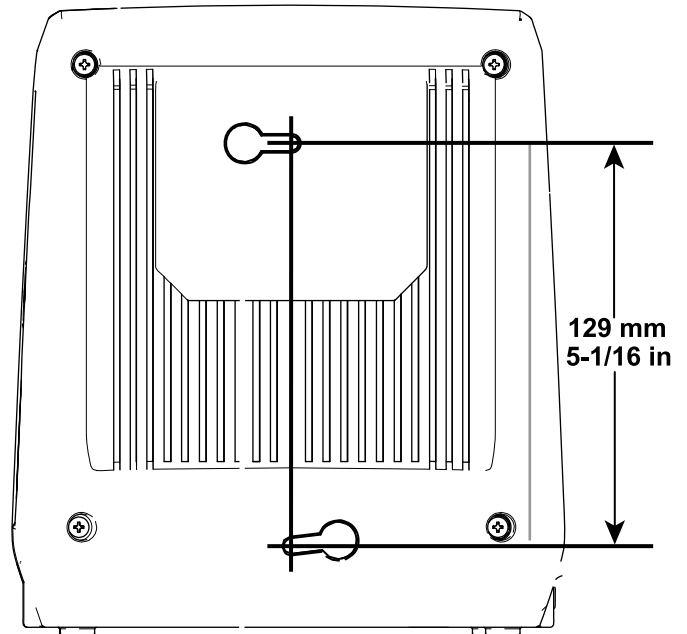
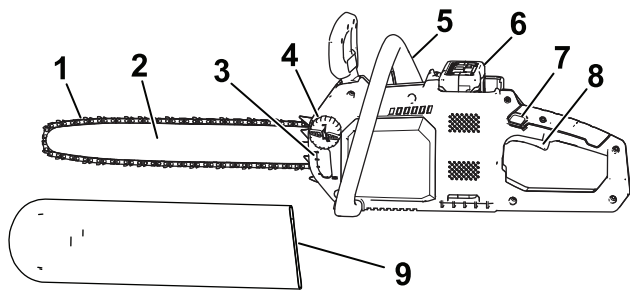

Figure 2

g194202

Product Overview



g192115

Figure 3
Left Side of Chain Saw

- | | |
|-----------------|-----------------------------|
| 1. Chain | 6. Battery pack |
| 2. Guide bar | 7. Trigger lock |
| 3. Oil window | 8. Trigger (on rear handle) |
| 4. Oil cap | 9. Guide bar cover |
| 5. Front handle | |

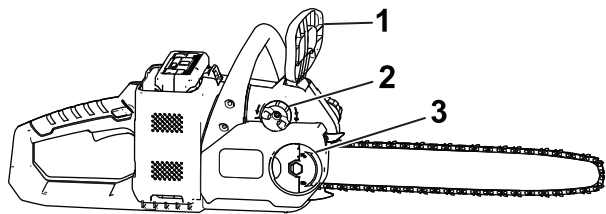

g192114

Figure 4
Right Side of Chain Saw

- | | |
|--------------------------|-------------|
| 1. Chain brake | 3. Wing nut |
| 2. Chain tensioning knob | |

Specifications

Appropriate Temperature Ranges

Charge the battery at	0°C (32°F) to 40°C (104°F)*
Use products at	-15°C (5°F) to 60°C (140°F)
Store products at	-15°C (5°F) to 60°C (140°F)
Unplug the charger if	Below 0°C (32°F) or above 40°C (104°F)

*Charging time will increase if you do not charge the battery within this range.

Store the tool, battery pack, and battery charger in an enclosed clean, dry area.

Operation

Before Using the Chain Saw

Before using the chain saw, do the following:

- Check the chain tension; refer to [Adjusting the Chain Tension \(page 17\)](#).
- Clean and check the chain components for excessive wear or damage and replace them as needed; refer to [Servicing the Guide Bar, Chain, and Drive Sprocket \(page 17\)](#) and [Sharpening the Chain \(page 19\)](#).
- Check the oil level; refer to [Checking the Oil Level and Adding Bar and Chain Oil \(page 16\)](#).
- Check the chain brake; refer to [Checking the Chain Brake \(page 16\)](#).

Starting the Chain Saw

1. Make sure that the vents on the chain saw ([Figure 5](#) and [Figure 6](#)) are free from dust and debris.

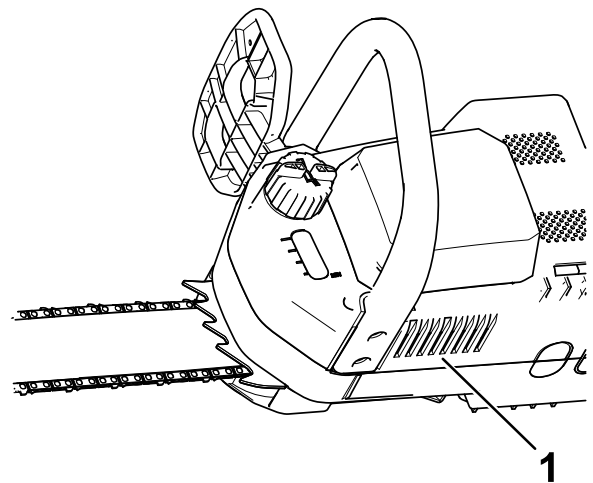

g197204

Figure 5

1. Vent

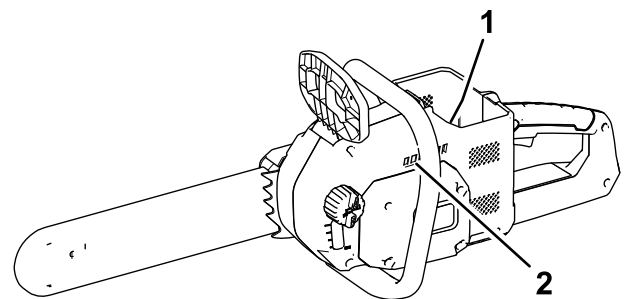

g197205

Figure 6

1. Vent (inside the battery cavity)
2. Vent cavity

- Set the chain saw down on a level surface.
- Align the tongue of the battery pack with the battery cavity in the chain saw (Figure 7).

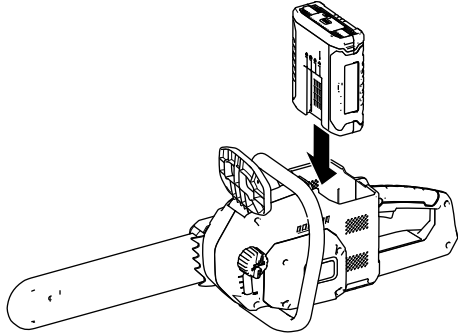

Figure 7

g228731

- Push the battery pack into the battery cavity until the battery pack locks into place.
- Remove the protective cover from the chain.
- Ensure that the chain brake is in the OPERATING position (Figure 8).

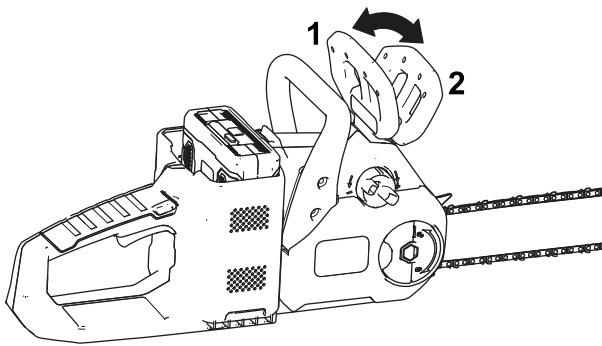

Figure 8

g192111

- Chain brake (OPERATING position)
- Chain brake (STOP position)

- With 1 hand on the front handle and the other on the rear handle, press the trigger lock, then squeeze the trigger (Figure 9).

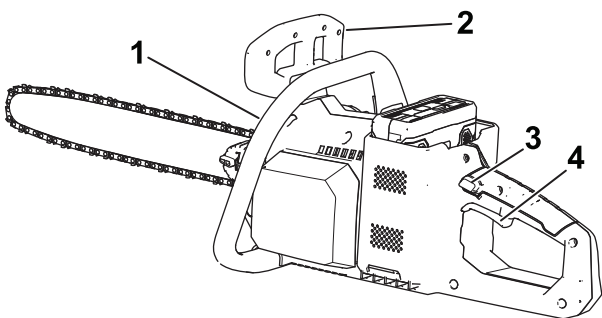

Figure 9

g192113

- Front handle
- Chain brake
- Trigger lock
- Trigger

Shutting Off the Chain Saw

To shut off the chain saw, release the trigger.

Whenever you are not using the saw or are transporting the saw to or from the work area, move the chain brake to the STOP position (Figure 8) and remove the battery.

Cutting with the Chain Saw

⚠ WARNING

Operating a chain saw improperly can cause serious personal injury or death.

Read and follow all operating instructions carefully to avoid possible personal injury.

⚠ WARNING

Kickback can cause serious or fatal injury to you.

Always ensure that the chain brake system is working properly before you operate the chain saw.

Avoid touching objects to be cut with the tip of the chain saw.

There are 2 types of kickback:

- A fast **upward** motion of the chain saw that results when the chain at the nose or top of the bar contacts an object
- A fast **backward** motion of the chain saw that results when the chain at the nose or top of the bar is pinched by the object being cut

Figure 10 shows the area of the bar to avoid contacting an object to prevent kickback.

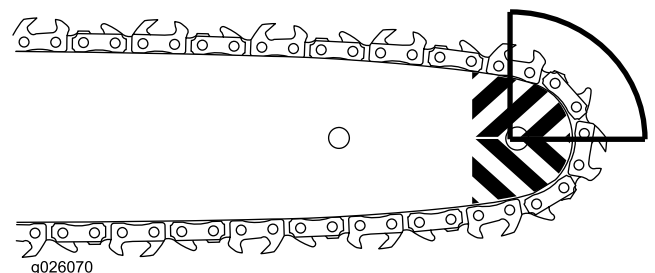

g026070

g026070

Figure 10

- Grip the chain saw with 2 hands, with your left hand on the front handle and your right hand on the rear handle as shown in Figure 11.

Note: Keeping your left arm straight with your elbow locked helps reduce kickback.

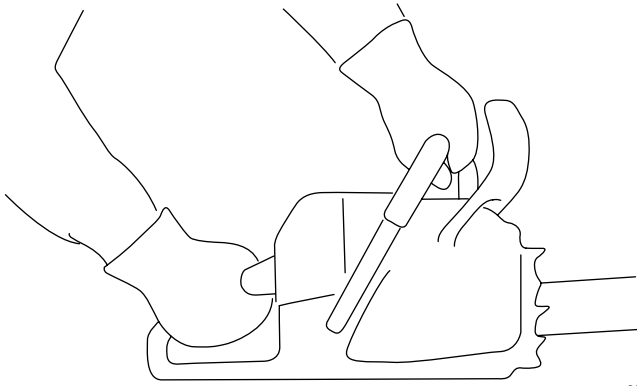

Figure 11

g204033

2. Stand to the left side of the chain saw and not in line with the chain, and position yourself for balanced, stable footing while sawing.
3. Stand on solid, even ground in front of the wood to be cut.
4. While cutting, have the wood near the chain saw head, at the exposed near end of the guide bar.

You can use the bucking teeth (Figure 12) to add pressure but it works best with a sharp-toothed chain.

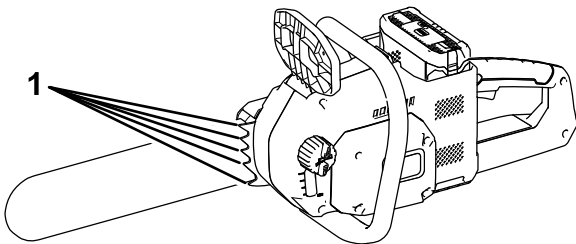

Figure 12

g200720

1. Bucking teeth

5. Press the chain saw lightly against the wood, allowing the weight of the chain saw to drive the cutting.
6. Keep steady pressure on the chain saw throughout the cut, and release pressure only near the end of the cut.

Pruning a Tree

⚠ WARNING

Cutting higher limbs from a tree off the ground can put you in an unstable position that could be unsafe for you while handling a chain saw, resulting in possible serious personal injury or death to you or bystanders.

When cutting limbs from a standing tree, use the following practices:

- Do not climb on limbs or branches with a chain saw.
- Do not overreach, and cut with both hands on the chain saw.
- Ensure that all bystanders are away from the area where branches may fall.

1. Grip the chain saw as shown in Figure 11.
2. While cutting small branches, apply light pressure to the branch to be cut.
3. While cutting larger branches, make a shallow undercut and then complete the cut from the topside of the branch.
 - A. Cut from the underside of the limb about 15 cm (6 inches) from the trunk. Cut a third of the way through the limb.
 - B. Cut 5.0 to 10.0 cm (2 to 4 inches) farther out on the limb and from above. Cut the limb until it falls.
 - C. Cut about a third of the diameter of the limb stub from underneath as close to the trunk as possible.
 - D. Cut the limb stub from above so that it meets the previous cut as close to the trunk as possible.

Felling a Tree

⚠ WARNING

Cutting standing trees requires expertise and poses hazards.

- Before attempting to cut a big tree, practice cutting a few branches, limbs, or small logs to familiarize yourself with the chain saw.
- Do not use this chain saw to fell large trees with a diameter larger than the length of the guide bar.

The proper operator stance for felling a tree is shown in Figure 13.

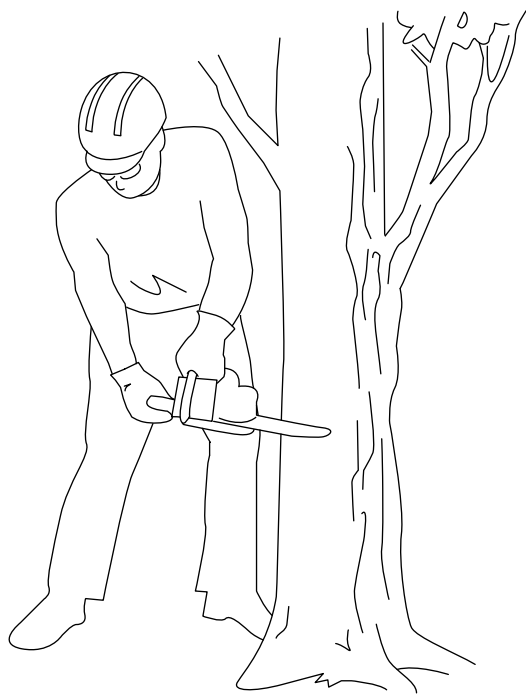
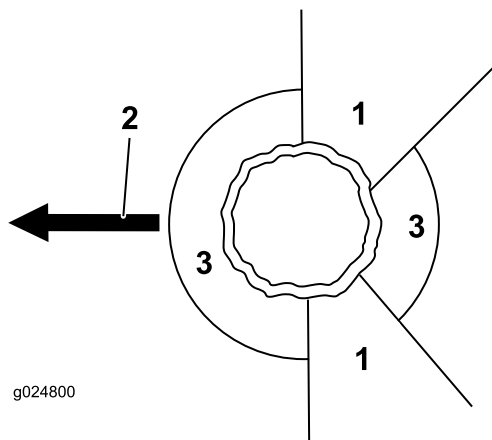

Figure 13

g195831

1. Determine the direction that the tree will fall. Consider the wind direction, if there are heavier limbs on 1 side of the tree, and the natural tilt of the tree, if any.
2. Determine a clear, safe retreat path away from the danger area; refer to Figure 14.



g024800

Figure 14

g024800

1. Retreat path
2. 45 degree angle
3. Danger area

3. Grip the chain saw as shown in (Figure 11).
4. Make the first cut a third of the way through the tree diameter on the side where you want the tree to fall (Figure 15).

Note: Making this cut prevents the chain saw from being pinched while making the next cut.

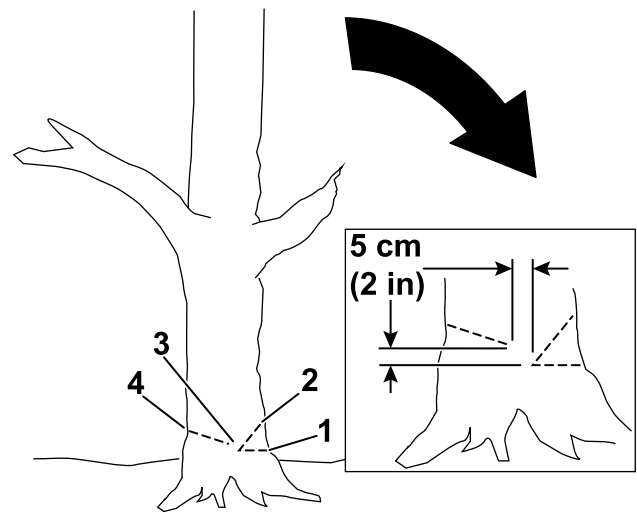

g228707

Figure 15

1. First cut
2. Second cut
3. Hinge
4. Back cut

5. Make a second cut to form a notch, starting the cut at least 5 cm (2 inches) above and away from the first cut (Figure 15).
6. Make the back cut from the opposite side of the notch and about 5 cm (2 inches) higher than the bottom of the notch as shown in Figure 15.

Important: Stop the third cut 2.5 to 5.0 cm (1 to 2 inches) from the notch to form a hinge between the cuts (Figure 15), which keeps the tree from falling in the wrong direction or twisting as it falls.

Note: As the back cut nears the hinge (Figure 15), the tree should begin to fall.

7. When the tree begins to fall, remove the chain saw, shut it off, put it down, and retreat along the path you determined in step 2.

Important: If the tree begins to fall in an undesired direction, immediately stop the cut, shut off the chain saw, put the chain saw down, and use a wedge to open the cut and push the tree in the desired direction.

Limbing a Fallen Tree

1. Grip the chain saw as shown in [Figure 11](#).
2. Cut off the smaller limbs from the tree that are not supporting its weight off the ground.

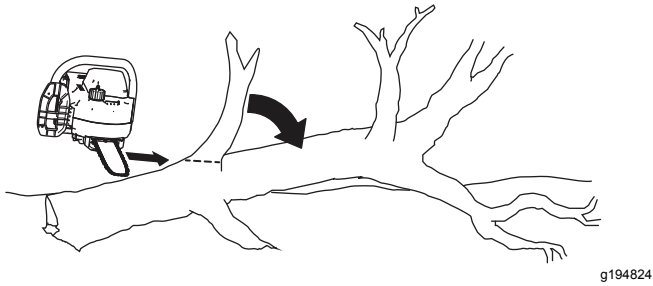

Figure 16



Figure 17

3. Cut the larger limbs that support the weight of the tree from the bottom upward so that the limbs do not pinch the saw blade ([Figure 18](#)).

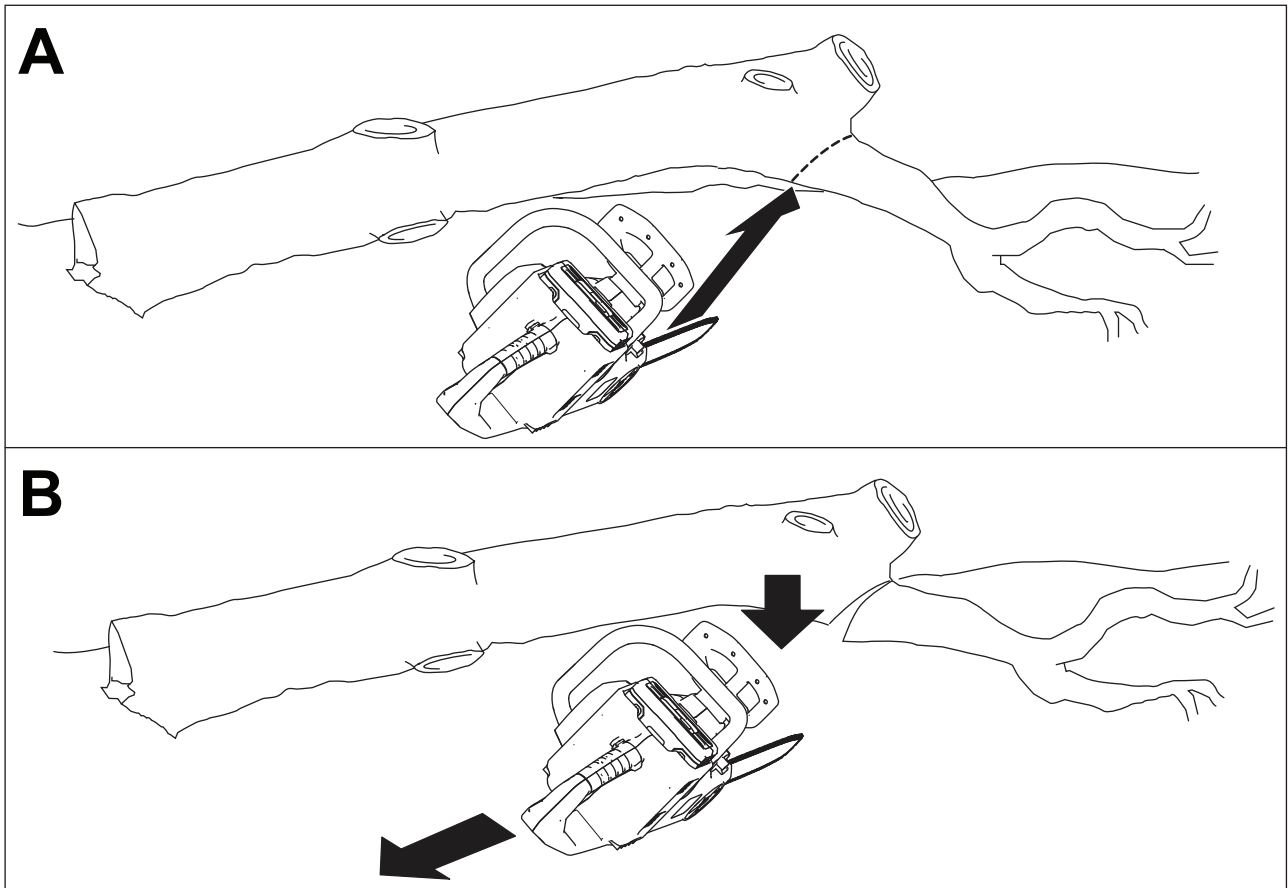

Figure 18

Bucking a Log

- If you are cutting branches from a fallen tree or cutting a log into lengths, support the log off the ground (preferably on a sawbuck); refer to [Figure 19](#).

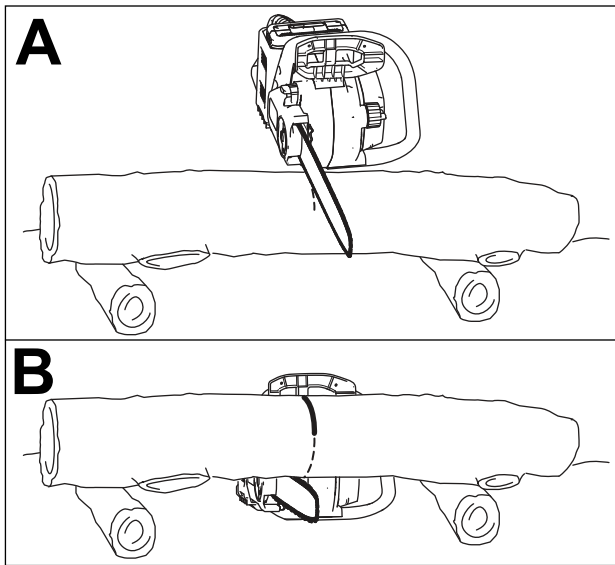

Figure 19

g194820

- If the log is supported on an end, cut from the top. If the chain saw binds in the cut, do not attempt to free it by running the motor. Shut off the saw, then use a wedge to pry open the cut and release the saw.
- If the log is supported on both ends, start from the top and cut about a third of the way through the log ([Figure 19A](#)). Make a second cut from the underside to meet the first cut ([Figure 19B](#)). This keeps the log from pinching the saw.
- If the log is supported along its entire length, cut all the way through the log from the top.
- If the log is supported on both ends but not in the middle, cut a third of the diameter from the top, then either cut from the bottom or roll the log over to meet the first cut ([Figure 20](#)).

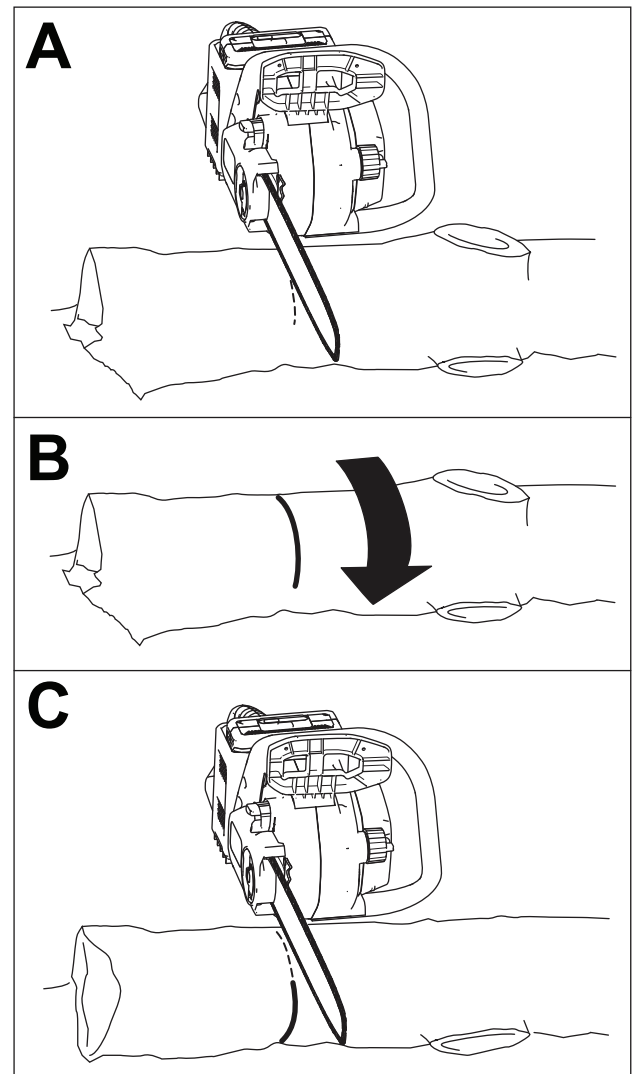
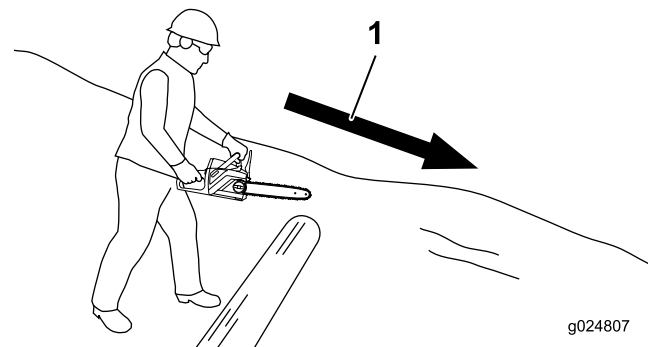

Figure 20

g194819

- If the log is on a hill, always stand on the uphill side of the log ([Figure 21](#)).



g024807

Figure 21

g024807

1. Direction of slope

Removing the Battery Pack

1. Place the chain saw on a flat surface.
2. Press down on the latch and remove the battery pack from the cavity.

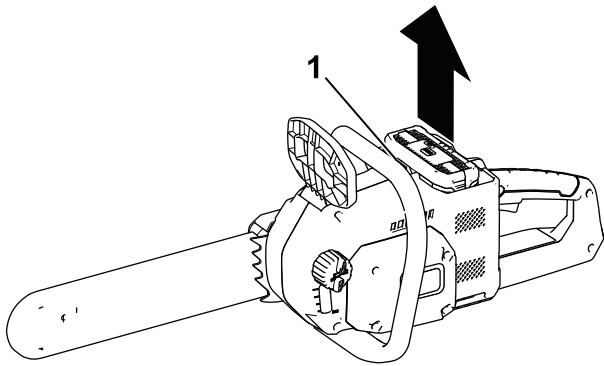
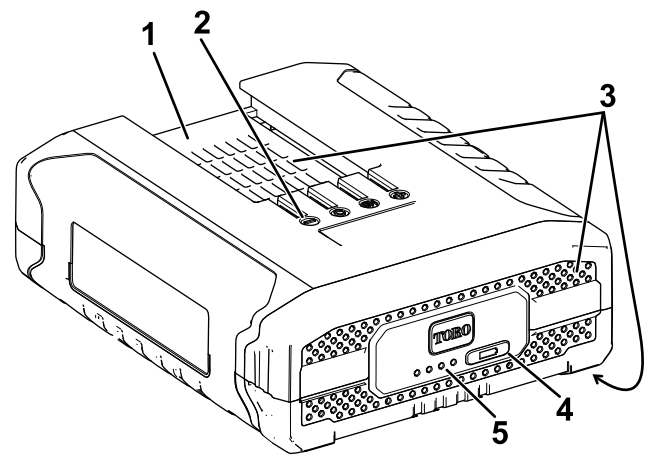

Figure 22

g192109

1. Latch



g228487

Figure 23

1. Battery pack cavity
2. Battery pack terminals
3. Battery pack venting areas
4. Battery-charge-indicator button
5. LED indicators (current charge)

Charging the Battery Pack

Important: Read all safety precautions.

Important: Charge the battery pack only in temperatures that are within the appropriate range; refer to [Specifications \(page 8\)](#).

Note: At any time, press the battery-charge-indicator button on the battery pack to display the current charge (LED indicators).

1. Make sure that the vents on the battery pack are clear of any dust and debris.
2. Line up the cavity in the battery pack ([Figure 23](#)) with the tongue on the charger.

3. Make sure that the vents on the battery charger are clear of any dust and debris.
4. Slide the battery pack into the charger until it is fully seated ([Figure 24](#)).

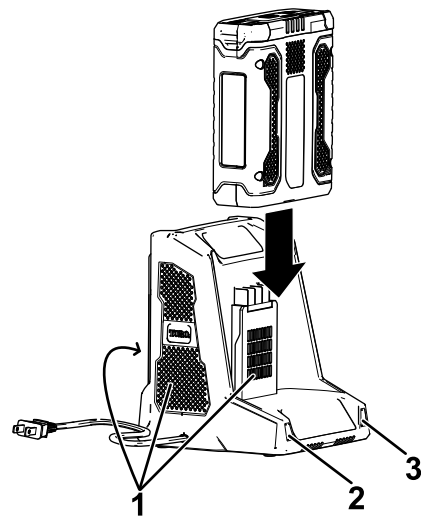

Figure 24

g194423

1. Charger venting areas
2. Left indicator light
3. Right indicator light

5. To remove the battery pack, slide the battery backward out of the charger.
6. Refer to the following table to interpret the LED indicators on the battery charger.

Left Light	Right Light	Indicates:
Off	Red	Charger is on; no battery pack inserted
Red	Red	Battery pack is charging
Green	Red	Battery pack is charged
Orange	Red	Battery pack is too warm
Red Blinking	Red	Replace the battery pack

Installing the Battery Pack

1. Set the chain saw down on a level surface.
2. Align the tongue of the battery pack with the battery cavity in the chain saw ([Figure 25](#)).

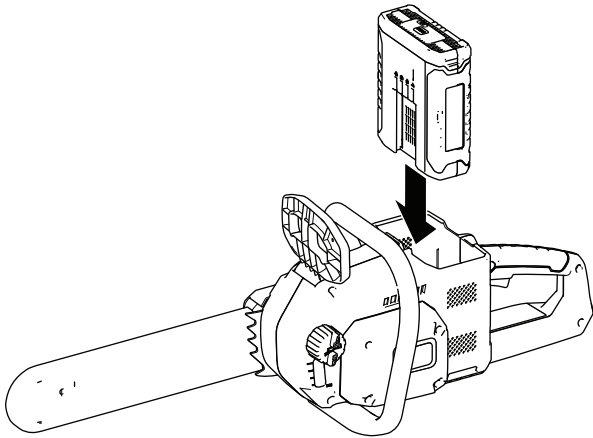

Figure 25

g192108

-
3. Push the battery pack into the battery cavity until the battery pack locks into place.

Maintenance

Recommended Maintenance Schedule(s)

Maintenance Service Interval	Maintenance Procedure
Before each use or daily	<ul style="list-style-type: none"> • Check the oil level and add bar and chain oil if necessary. • Check the chain brake. • Check the chain tension and adjust it if necessary. • Check the chain for sharpness; contact an Authorized Service Dealer to have the chain sharpened or replaced.
After each battery drain cycle	<ul style="list-style-type: none"> • Check the oil level and add bar and chain oil if necessary. • Check the chain brake. • Check the chain tension and adjust it if necessary.
Yearly or before storage	<ul style="list-style-type: none"> • Service the guide bar, chain, and drive sprocket. • Check the chain for sharpness; contact an Authorized Service Dealer to have the chain sharpened or replaced.

Checking the Oil Level and Adding Bar and Chain Oil

Service Interval: Before each use or daily

After each battery drain cycle

1. Place the chain saw on a flat surface and remove the battery pack; refer to [Removing the Battery Pack \(page 14\)](#).
2. Check the oil level in the window. If you cannot see oil in the window, add bar and chain oil to the chain saw ([Figure 26](#)).

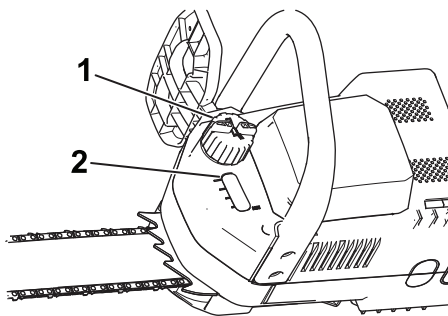

Figure 26

g192110

1. Oil cap
2. Window

3. Clean the area around the oil cap ([Figure 26](#)).

Note: Make sure that you do not allow debris/wood chips to enter the oil tank.
4. Remove the cap and pour oil into the chain saw until the oil fills the window ([Figure 26](#)).

Note: Do not fill the chain saw higher than the bottom of the fill neck.
5. Clean up any spilled oil and replace the oil cap.

Checking the Chain Brake

Service Interval: Before each use or daily

After each battery drain cycle

1. Place the chain saw on a flat surface and remove the battery pack; refer to [Removing the Battery Pack \(page 14\)](#).
2. Engage the chain brake by moving the chain brake forward to the STOP position ([Figure 27](#)).

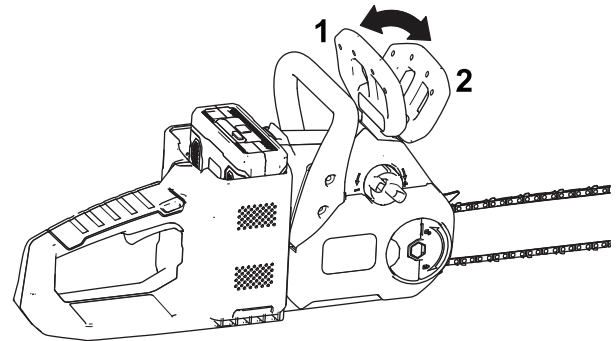

Figure 27

g192111

1. Chain brake (OPERATING position)
2. Chain brake (STOP position)

3. Grip the chain with a gloved hand and attempt to pull it around the guide bar; the chain should not move around the guide bar. If it does, take the chain saw to an Authorized Service Dealer for repair.
4. Disengage the chain brake by moving the chain brake rearward to the OPERATING position ([Figure 27](#)).
5. Grip the chain with a gloved hand and attempt to pull it around the guide bar; the chain should

move around the guide bar. If it does not, take the chain saw to an Authorized Service Dealer for repair.

Adjusting the Chain Tension

Service Interval: Before each use or daily
After each battery drain cycle

Ensure that the chain is properly tensioned. A loose chain will shorten the life of the drive sprocket and the guide bar and may break the chain. An overtightened chain will overheat the guide bar and chain, causing rapid wear and possible motor burnout. Also, check the chain tension after a few cuts. A new chain usually stretches and requires adjustment after its first use.

The chain tension is correct when you are able to use a gloved hand to pull the chain smoothly around the guide bar. The chain should remain in contact with the bottom edge of the guide bar.

⚠ DANGER

Contact with the chain saw teeth can cause serious personal injury.

- **Remove the battery pack before adjusting or maintaining the chain saw.**
 - **Always wear gloves when adjusting or maintaining the chain saw.**
1. Place the chain saw on a level surface and remove the battery pack; refer to [Removing the Battery Pack \(page 14\)](#).
 2. Unfold the wing-nut tab and loosen, but do not remove the wing nut on the cover ([Figure 27](#)).
 3. Hold up the tip of the guide bar ([Figure 28](#)).

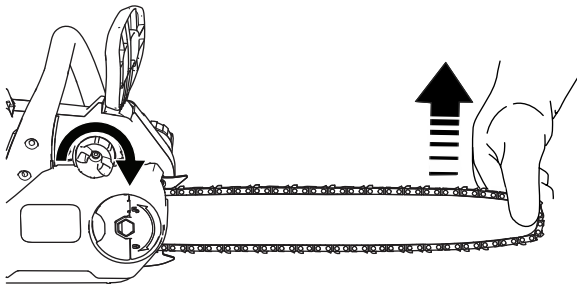

Figure 28

g192117

4. Adjust the chain.
 - **To tighten the chain**, turn the chain tensioning knob clockwise.
 - **To loosen the chain**, turn the chain tensioning knob counterclockwise

Adjust the chain until the chain touches the bottom edge of the guide bar, then tighten the knob an additional 1/8 to 1/4 turn.

5. Tighten the wing nut until it is snug and fold the wing-nut tab ([Figure 29](#)).
6. Check the chain tension; if the chain is loose, repeat this procedure.

Servicing the Guide Bar, Chain, and Drive Sprocket

Service Interval: Yearly or before storage

⚠ DANGER

Contact with the chain saw teeth can cause serious personal injury.

- **Remove the battery pack before adjusting or maintaining the chain saw.**
- **Always wear gloves when adjusting or maintaining the chain saw.**

1. Place the chain saw on a flat surface and remove the battery pack; refer to [Removing the Battery Pack \(page 14\)](#).
2. Unfold the wing-nut tab and remove the wing nut that secures the cover ([Figure 29](#)).

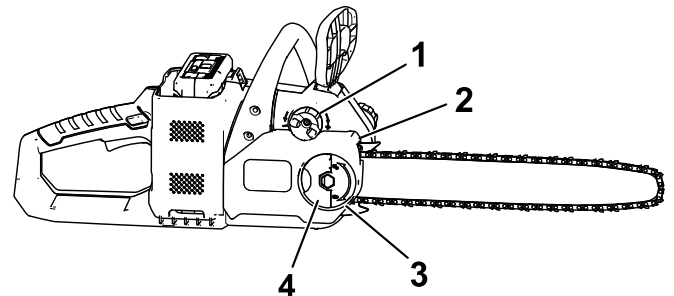

Figure 29

g228710

- | | |
|--------------------------|-----------------|
| 1. Chain tensioning knob | 3. Wing nut |
| 2. Cover | 4. Wing-nut tab |

3. Loosen the chain by turning the chain-tightening screw counterclockwise ([Figure 29](#)).
4. Separate the chain from the guide bar and set them aside.
5. Remove the clip, spacer, and drive sprocket from the chain saw ([Figure 30](#)).

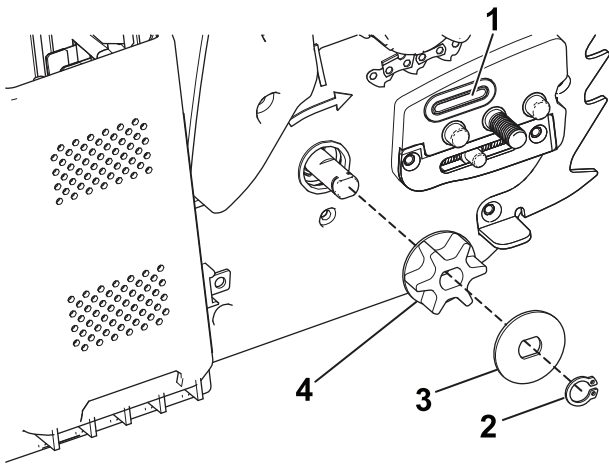

Figure 30

g192116

- | | |
|----------------|-------------------|
| 1. Oil passage | 3. Spacer |
| 2. Clip | 4. Drive sprocket |

6. Inspect the drive sprocket; if it is excessively worn or damaged, replace it.
7. Check the oil passage (Figure 30) for debris and clean the area if necessary.
8. Install the drive sprocket, spacer, and clip.
9. Clean the guide bar and chain; use a wire or a small flat-head screwdriver to remove dirt and debris from the groove along the edge of the guide bar, starting from the sprocket on the front end and moving rearward.

If the guide bar or grooves are damaged or the sprocket on the front end does not rotate freely, replace the guide bar; if the chain is excessively worn or damaged, replace it.

10. Place the chain around the drive sprocket on the front end of the guide bar, **with the cutting edge of the chain teeth on the top of the bar facing forward** as shown in the diagram on the side of the chain saw (Figure 31C).

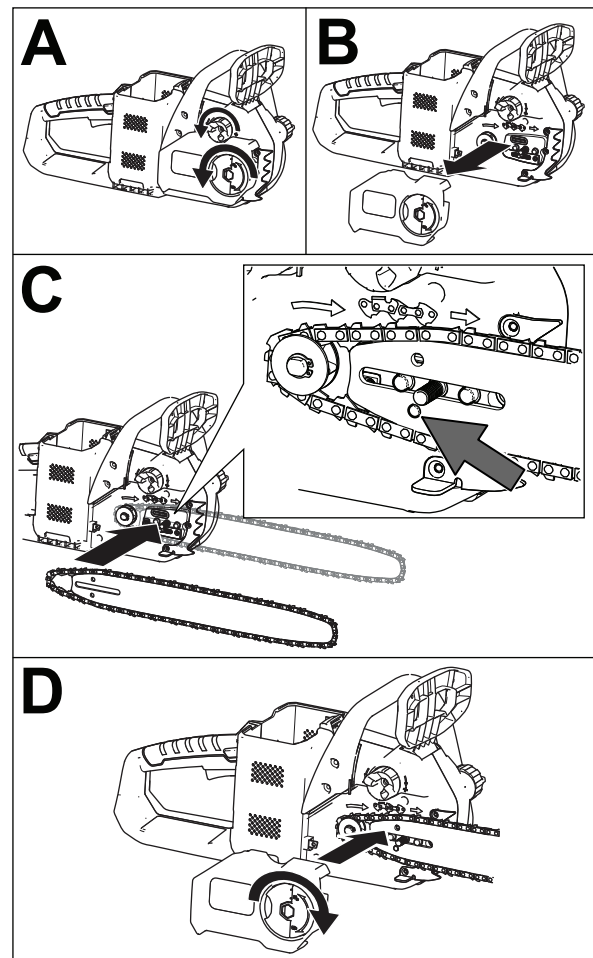

Figure 31

g192112

11. Feed the chain around the guide bar and align the chain teeth into the groove of the bar.
12. Position the open loop of the chain (not on the guide bar) around the drive sprocket on the chain saw and install the guide bar and attached chain onto the chain saw as shown in Figure 31.

Important: Ensure that the chain adjusting stud is inserted into the hole indicated by the arrow in Figure 31C. You may need to rotate the chain tensioning knob to fit the stud into the hole in the guide bar.

13. Install the cover and the wing nut, but do not fully tighten the wing nut (Figure 31D). Fold the wing-nut tab.
14. Adjust the chain tension; refer to [Adjusting the Chain Tension](#) (page 17).

Sharpening the Chain

Service Interval: Before each use or daily
Yearly or before storage

The chain needs sharpening or replacement when you must force it onto the wood or it produces smaller chips than when it was new.

Contact an Authorized Service Dealer to have the chain sharpened or replaced.

Preparing the Battery Pack for Recycling

Important: Upon removal, cover the terminals of the battery pack with heavy-duty adhesive tape. Do not attempt to destroy or disassemble the battery pack or remove any of its components. Recycle or properly dispose of lithium-ion battery packs at a battery recycling facility.



For more information on recycling lithium-ion battery packs and to locate the battery recycling facility closest to you, visit www.Call2Recycle.org (US and Canada only). If you are located outside of the US and Canada, please contact your authorized Toro distributor.

Service

Should the chain saw need service, take the product to your Authorized Service Dealer.

Storage

Important: Store the tool, battery pack, and charger only in temperatures that are within the appropriate range; refer to [Specifications \(page 8\)](#).

Important: If you are storing the tool for a year or longer, remove the battery pack from the tool and charge the battery pack until 2 or 3 LED indicators turn blue on the battery. Do not store a fully charged or fully depleted battery. When you are ready to use the tool again, charge the battery pack until the left indicator light turns green on the charger or all 4 LED indicators turn blue on the battery.

- Clean all foreign material from the product.
- Store the tool, battery pack, and battery charger in a well-ventilated place that is inaccessible to children.
- Keep the tool, battery pack, and battery charger away from corrosive agents such as garden chemicals and de-icing salts.
- To reduce the risk of serious personal injury, do not store the battery pack outside or in vehicles.
- Store the tool, battery pack, and battery charger in an enclosed clean, dry area.

Troubleshooting

Perform only the steps described in these instructions. All further inspection, maintenance, and repair work must be performed by an authorized service center or a similarly qualified specialist if you cannot solve the problem yourself.

Problem	Possible Cause	Corrective Action
The motor does not run or runs intermittently.	<ol style="list-style-type: none"> 1. The chain brake is engaged. 2. The battery pack is low on charge. 3. The battery pack is not fully seated. 4. The battery pack is too hot. 5. The battery pack has exceeded high amperage limits. 6. There is debris under the cover. 	<ol style="list-style-type: none"> 1. Disengage the chain brake by moving the chain brake rearward. 2. Charge the battery pack. 3. Ensure that the battery pack is inserted all the way into the housing. 4. Allow the battery pack to cool. 5. Release the trigger, then press the trigger switch. 6. Remove the cover and clean out any debris.
The motor runs, but the chain does not rotate.	<ol style="list-style-type: none"> 1. The chain is not properly seated on the drive sprocket. 	<ol style="list-style-type: none"> 1. Install the chain and ensure that the links are properly seated in the drive sprocket.
The chain brake does not engage.	<ol style="list-style-type: none"> 1. There is a chain brake malfunction. 	<ol style="list-style-type: none"> 1. Immediately take the chain saw to a Authorized Service Dealer.
The chain saw does not properly cut.	<ol style="list-style-type: none"> 1. The chain is not tensioned correctly. 2. The chain is dull. 3. The chain is installed backward. 4. The chain is dry. 	<ol style="list-style-type: none"> 1. Set the proper tension on the chain. 2. Replace the chain. 3. Install the chain correctly. 4. Check the oil level.
The chain oil is not lubricating properly.	<ol style="list-style-type: none"> 1. The oil port is plugged. 2. The oil groove in the guide bar is plugged. 3. The strainer in the oil tank is plugged (if equipped). 	<ol style="list-style-type: none"> 1. Clean out debris from the oil port. 2. Clean out debris in the bar. 3. Clean debris out of the strainer in the oil tank (if equipped).
The battery pack loses charge quickly.	<ol style="list-style-type: none"> 1. The battery pack is over or under the appropriate temperature range. 	<ol style="list-style-type: none"> 1. Move the battery pack to a place where it is dry and the temperature is between 0°C (32°F) and 40°C (104°F).
The battery charger is not working.	<ol style="list-style-type: none"> 1. The battery charger is over or under the appropriate temperature range. 2. The outlet that the battery charger is plugged into does not have power. 	<ol style="list-style-type: none"> 1. Unplug the battery charger and move it to a place where it is dry and the temperature is between 0°C (32°F) and 40°C (104°F). 2. Contact your licensed electrician to repair the outlet.
The chain saw does not run or run continuously.	<ol style="list-style-type: none"> 1. There is moisture on the leads of the battery pack. 2. The battery pack is not fully installed into the chain saw. 	<ol style="list-style-type: none"> 1. Allow the battery pack to dry or wipe it dry. 2. Remove and then replace the battery pack into the chain saw making sure that it is fully installed and latched.
The battery pack shows only 3 LED indicators after only a few seconds of using a fully charged battery.	<ol style="list-style-type: none"> 1. This is a normal occurrence. 	<ol style="list-style-type: none"> 1. Shut off the tool and press the battery-charge-indicator button or the remove the battery from the tool to display the actual battery charge.
All 4 LED indicators are blinking on the battery pack after you press the battery-charge-indicator button on the battery pack and the current charge displays (when the battery pack is not in use).	<ol style="list-style-type: none"> 1. The battery pack is over or under the appropriate temperature range. 	<ol style="list-style-type: none"> 1. Move the battery pack to a place where it is dry and the temperature is between 0°C (32°F) and 40°C (104°F).

Problem	Possible Cause	Corrective Action
All 4 LED indicators are blinking on the battery pack after releasing the trigger (when the battery pack is in use).	1. The battery pack is over or under the appropriate temperature range.	1. Move the battery pack to a place where it is dry and the temperature is between 0°C (32°F) and 40°C (104°F).
2 LED indicators are blinking on the battery pack after you press the battery-charge-indicator button on the battery pack and the current charge displays (when the battery pack is not in use).	1. There is a difference in voltage between cells in the battery pack.	1. Place the battery on the charger until it is fully charged.
2 LED indicators are blinking on the battery pack after releasing the trigger (when the battery pack is in use).	1. There is a difference in voltage between cells in the battery pack.	1. Place the battery on the charger until it is fully charged.
1 LED indicator is blinking on the battery pack.	1. The battery pack voltage is low.	1. Place the battery pack on the charger.
It is difficult to remove the battery pack from the tool.	1. The battery pack/tool is new or there is corrosion in the battery terminals and/or the terminals on the tool.	1. Clean the terminals on the battery pack and the tool. Then apply dielectric grease to the battery terminals; do not use any other type of lubricant as it can damage the terminals.

Notes:

Notes:



Count on it.