



**Count on it.**

**Operator's Manual**

# 53cm Heavy-Duty Recycler®/Rear Bagger Lawn Mower

Model No. 22291—Serial No. 402100000 and Up

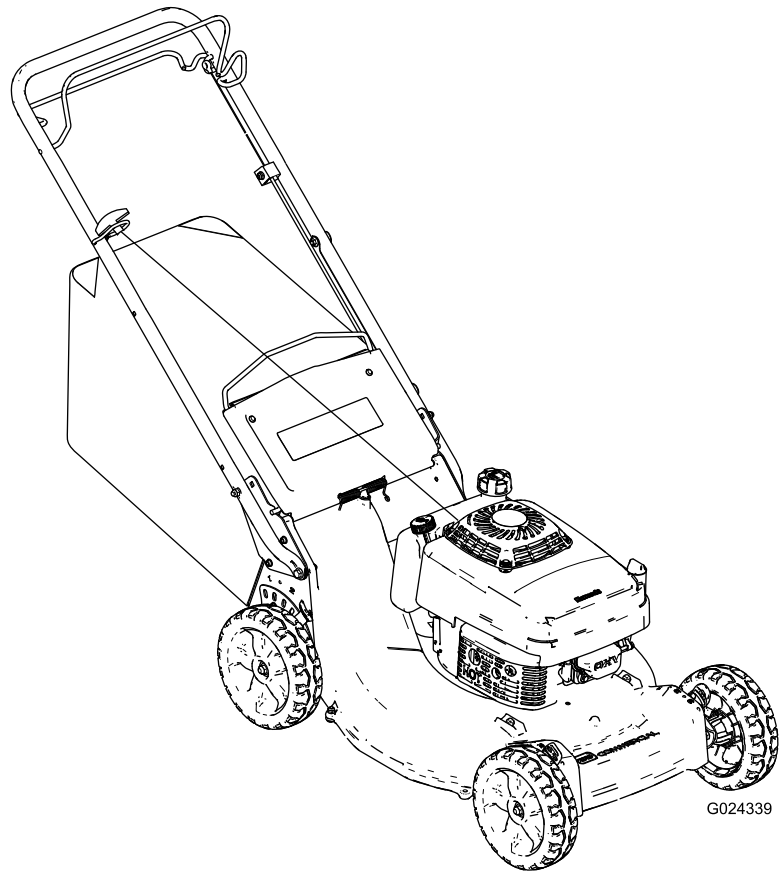

G024339



This product complies with all relevant European directives; for details, please see the separate product specific Declaration of Conformity (DOC) sheet.



g000502

**Figure 2**  
Safety-alert symbol

# Introduction

This rotary-blade, walk-behind lawn mower is intended to be used by residential homeowners or professional, hired operators. It is designed primarily for cutting grass on well-maintained lawns on residential or commercial properties. It is not designed for cutting brush or for agricultural uses.

Read this information carefully to learn how to operate and maintain your product properly and to avoid injury and product damage. You are responsible for operating the product properly and safely.

You may contact Toro directly at [www.Toro.com](http://www.Toro.com) for product and accessory information, help finding a dealer, or to register your product.

Whenever you need service, genuine Toro parts, or additional information, contact an Authorized Service Dealer or Toro Customer Service and have the model and serial numbers of your product ready. [Figure 1](#) identifies the location of the model and serial numbers on the product. Write the numbers in the space provided.

**Important:** With your smartphone or tablet, scan the QR code on the serial number decal to access warranty, parts, and other product information.

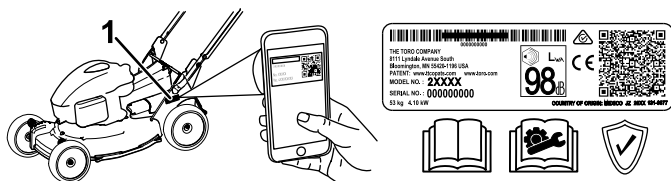

g226628

**Figure 1**

1. Model and serial number plate

Model No. _____
Serial No. _____

This manual identifies potential hazards and has safety messages identified by the safety-alert symbol ([Figure 2](#)), which signals a hazard that may cause serious injury or death if you do not follow the recommended precautions.

This manual uses 2 words to highlight information. **Important** calls attention to special mechanical information and **Note** emphasizes general information worthy of special attention.

**Gross or Net Torque:** The gross or net torque of this engine was laboratory rated by the engine manufacturer in accordance with the Society of Automotive Engineers (SAE) J1940 or J2723. As configured to meet safety, emission, and operating requirements, the actual engine torque on this class of mower will be significantly lower. Please refer to the engine manufacturer's information included with the machine.

Do not tamper with or disable safety devices on the machine, and check their proper operation regularly. Do not attempt to adjust or tamper with the engine speed control; doing so may create an unsafe operating condition, resulting in personal injury.

# Contents

Safety .....	3
General Safety .....	3
Safety and Instructional Decals .....	4
Setup .....	6
1 Installing the Handle .....	6
2 Installing the Recoil-Starter Rope in the Rope Guide.....	8
3 Filling the Crankcase with Oil .....	8
4 Adjusting the Self-Propel Drive .....	9
5 Assembling the Grass Bag.....	9
Product Overview .....	10
Specifications .....	10
Before Operation .....	11
Before Operation Safety .....	11
Filling the Fuel Tank.....	11
Checking the Engine-Oil Level.....	12
Adjusting the Cutting Height .....	12
During Operation .....	12
During Operation Safety .....	12
Starting the Engine .....	13
Shutting Off the Engine.....	14
Operating the Self-Propel Drive .....	14
Recycling the Clippings .....	14
Bagging the Clippings.....	15
Operating Tips .....	15
After Operation .....	16
After Operation Safety .....	16
Cleaning under the Machine .....	17
Maintenance .....	18
Recommended Maintenance Schedule(s) .....	18
Maintenance Safety.....	18
Servicing the Air Filter.....	19
Changing the Engine Oil.....	19
Servicing the Spark Plug.....	20
Adjusting the Self-Propel Drive .....	20
Maintaining the Blade .....	21
Storage .....	24
Preparing the Fuel System .....	24
Preparing the Engine .....	24
General Information.....	24
Removing the Machine from Storage.....	24
Troubleshooting .....	25

# Safety

This machine has been designed in accordance with EN ISO 5395:2013.

**Improperly using or maintaining this machine can result in injury. To reduce the potential for injury, comply with these safety instructions.**

**To ensure maximum safety, best performance, and to gain knowledge of the product, it is essential that you and any other operator of the mower read and understand the contents of this manual before the engine is ever started. Pay particular attention to the safety-alert symbol (Figure 2), which means Caution, Warning, or Danger. Read and understand the instruction because it has to do with safety. Failure to comply with the instruction may result in personal injury.**

## General Safety

This product is capable of amputating hands and feet and of throwing objects. Always follow all safety instructions to avoid serious personal injury.

Using this product for purposes other than its intended use could prove dangerous to you and bystanders.

- Read, understand, and follow the instructions and warnings in this *Operator's Manual* and on the machine and attachments before starting the engine.
- Do not put your hands or feet near moving parts of or under the machine. Keep clear of any discharge opening.
- Do not operate the machine without all guards and other safety protective devices in place and working on the machine.
- Keep bystanders and children a safe distance away from the machine. Do not allow children to operate the machine. Allow only people who are responsible, trained, familiar with the instructions, and physically capable to operate the machine.
- Stop the machine, shut off the engine, and wait for all moving parts to stop before servicing, fueling, or unclogging the machine.

Improperly using or maintaining this machine can result in injury. To reduce the potential for injury, comply with these safety instructions and always pay attention to the safety-alert symbol, which means Caution, Warning, or Danger—personal safety instruction. Failure to comply with these instructions may result in personal injury or death.

You can find additional safety information where needed throughout this manual.

# Safety and Instructional Decals

**Important:** Safety and instruction decals are located near areas of potential danger. Replace damaged decals.

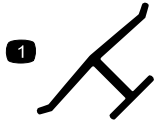

decaloemmarkt

## Manufacturer's Mark

1. This mark indicates that the blade is identified as a part from the original machine manufacturer.

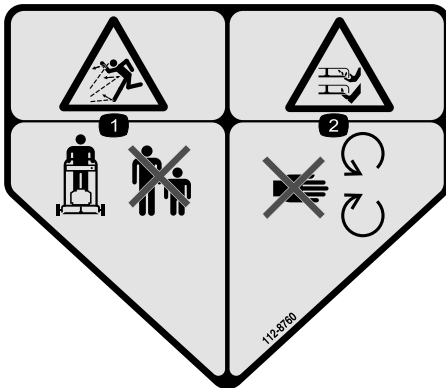

decal112-8760

## 112-8760

1. Thrown object hazard—keep bystanders a safe distance away from the machine.
2. Cutting/dismemberment of hand or foot—stay away from moving parts.

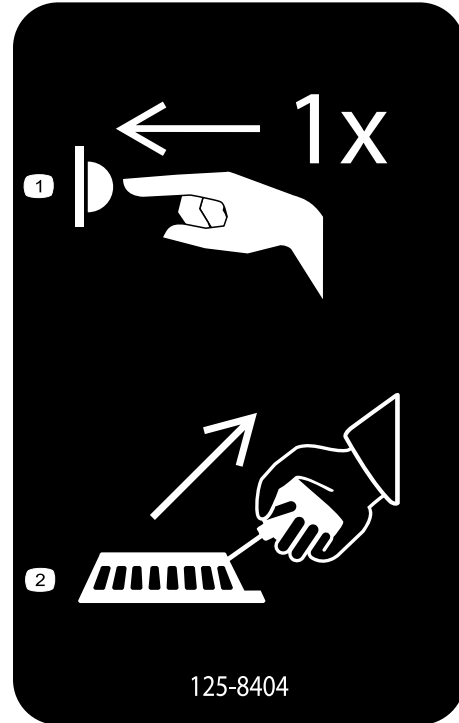

decal125-8404

## 125-8404

1. Push the primer once.
2. Pull the recoil-start handle.



decal125-8403

## 125-8403

### Kawasaki Non-BBC Units

1. Push the primer once.
2. Pull the recoil-start handle.

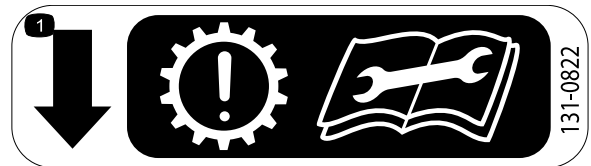

decal131-0822

## 131-0822

1. Self-propel drive—Attention; premature wear of the transmission may occur if the belt is over-tightened; before servicing or performing maintenance, read the *Operator's Manual*.



116-7583

decal116-7583

1. Warning—read the *Operator's Manual*. Do not operate this machine unless you are trained.
2. Thrown object hazard—keep bystanders a safe distance away from the machine.
3. Thrown object hazard—do not operate the machine without the rear-discharge plug or bag in place.
4. Cutting/dismemberment hazard of hand or foot, mower blade—stay away from moving parts; keep all guards in place.
5. Warning—wear hearing protection.
6. Cutting/dismemberment hazard of hand or foot, mower blade—do not operate up and down slopes; operate side to side on slopes; shut off the engine before leaving the operating position—pick up objects that the blades could throw; and look behind you when backing up.

# Setup

## Loose Parts

Use the chart below to verify that all parts have been shipped.

Procedure	Description	Qty.	Use
<b>1</b>	Handle	1	Install the handle.
	Hex-head-flange bolt (5/16 x 1-1/2 inches)	2	
	Carriage bolt (5/16 x 1-1/2 inches)	2	
	Flange nut (5/16 inch)	4	
<b>2</b>	No parts required	–	Install the recoil-starter rope in the rope guide.
<b>3</b>	No parts required	–	Fill the crankcase with oil.
<b>4</b>	No parts required	–	Adjust the self-propel drive.
<b>5</b>	No parts required	–	Assemble the grass bag.

**Important:** Remove and discard the protective plastic sheet that covers the engine and any other plastic or wrapping on the machine.

**Note:** Determine the left and right sides of the machine from the normal operating position.

# 1

## Installing the Handle

Parts needed for this procedure:

1	Handle
2	Hex-head-flange bolt (5/16 x 1-1/2 inches)
2	Carriage bolt (5/16 x 1-1/2 inches)
4	Flange nut (5/16 inch)

## Procedure

1. Remove the cable guard from the handle (Figure 3) by removing the 2 carriage bolts and 2 locknuts that hold the cable guard to the handle.

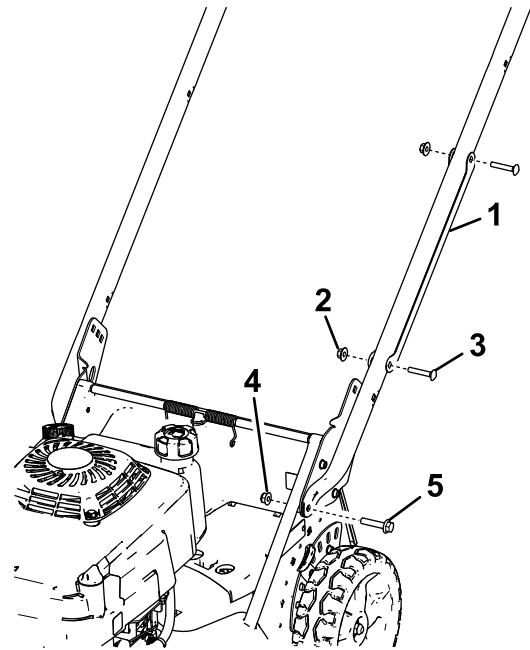

g024341

g024341

**Figure 3**

- |   |   |
|---|---|
| 1. Cable guard                          | 4. Flange nut—5/16 inch (2)                     |
| 2. Locknut (2)                          | 5. Hex-head-flange bolt—5/16 x 1-1/2 inches (2) |
| 3. Carriage bolt—1/4 x 1-1/2 inches (2) |   |

**Note:** Save the guard, the carriage bolts, and the locknuts so that you can install them onto the handle later in this procedure.

2. Install the handle ends onto the mower housing with 2 hex-head-flange bolts (5/16 x 1-1/2 inches) and 2 flange nuts (5/16 inch) as shown in [Figure 3](#).
3. Set the machine to the desired cutting height; refer to [Adjusting the Cutting Height \(page 12\)](#).
4. Route the control cables between the deck and the handle to protect the cables from being damaged ([Figure 4](#)).

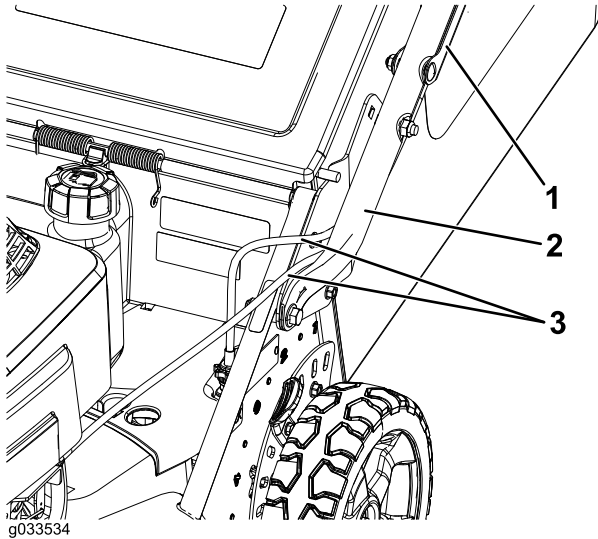

**Figure 4**

1. Cable guard
2. Handle
3. Cable(s)

5. Stand in the operating position to determine the handle height that is most comfortable for you ([Figure 5](#)).

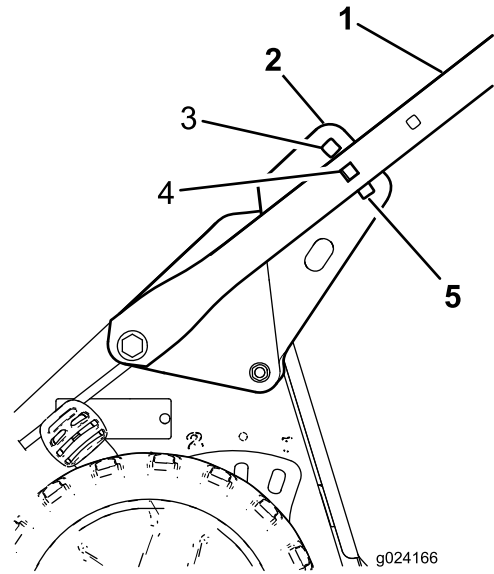
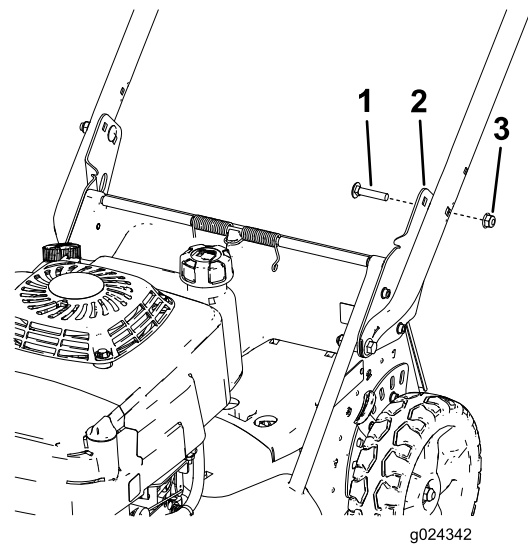

**Figure 5**

1. Handle
2. Handle bracket (2)
3. Highest handle height
4. Medium handle height
5. Lowest handle height

6. Secure the handle onto the handle brackets at your desired handle height with 2 carriage bolts (5/16 x 1-1/2 inches) and 2 flange nuts (5/16 inch) as shown in [Figure 6](#).

**Important:** Ensure that the bolt heads are on the inside of the handle and that the nuts are on the outside of the handle.



**Figure 6**

1. Carriage bolt—5/16 x 1-1/2 inches (2)
2. Handle bracket (2)
3. Flange nut—5/16 inch (2)

7. Position the cable guard onto the handle **with the cable(s) inside the guard**, and secure the guard to the handle with the 2 carriage bolts

and the 2 locknuts that you previously removed (Figure 3).

**Important:** Ensure that you do not pinch the cable(s) to the handle when you install the cable guards onto the handle.

# 3

## Filling the Crankcase with Oil

No Parts Required

### Procedure

**Important:** Your machine does not come with oil in the engine. Before starting the engine, fill the engine with oil.

### Engine Oil Specifications

Engine oil capacity	0.65 L (22 fl oz)
Oil viscosity	SAE 30 or SAE 10W-30 detergent oil
API service classification	SJ or higher

1. Move the machine to a level surface.
2. Remove the dipstick by rotating the cap counterclockwise and pulling it out (Figure 8).

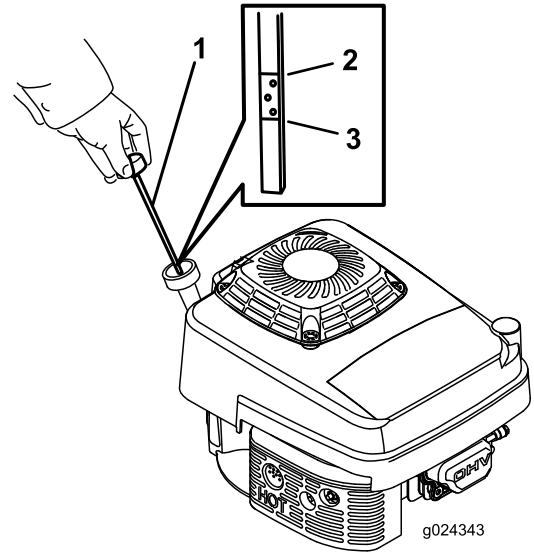

Figure 8

1. Dipstick
2. Full
3. Add

3. Carefully pour about 3/4 of the engine capacity of oil into the oil-fill tube.
4. Wait 3 minutes for the oil to settle in the engine.
5. Wipe the dipstick clean with a clean cloth.
6. Insert the dipstick into the oil-fill tube, then remove the dipstick.
7. Read the oil level on the dipstick (Figure 8).

# 2

## Installing the Recoil-Starter Rope in the Rope Guide

No Parts Required

### Procedure

**Important:** To start the engine safely and easily whenever you use the machine, install the recoil-starter rope in the rope guide.

Hold the blade-control bar to the upper handle and pull the recoil-starter rope through the rope guide on the handle (Figure 7).

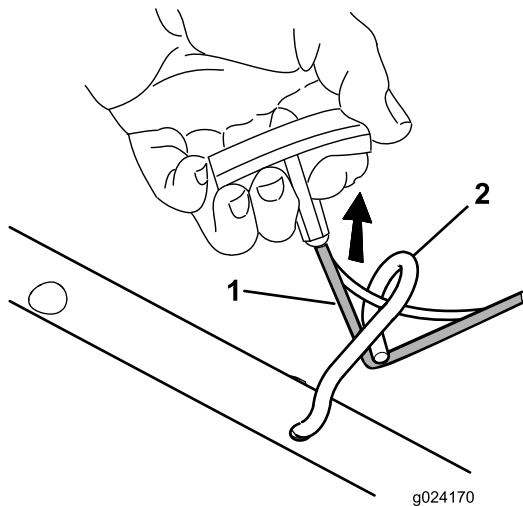

Figure 7

1. Recoil-starter rope
2. Rope guide



- If the oil level on the dipstick is too low, carefully pour a small amount of oil into the oil-fill tube, wait 3 minutes, and repeat steps 5 through 7 until the oil on the dipstick is at the correct level.
- If the oil level on the dipstick is too high, drain the excess oil until the oil on the dipstick is at the correct level; refer to [Changing the Engine Oil \(page 19\)](#).

**Important:** If the oil level in the engine is too low or too high and you run the engine, you may damage the engine.

8. Install the dipstick into the oil-fill tube securely.

## 4

### Adjusting the Self-Propel Drive

No Parts Required

#### Procedure

**Important:** You must adjust the self-propel-drive cable before you operate the machine for the first time. Refer to [4 Adjusting the Self-Propel Drive \(page 9\)](#).

## 5

### Assembling the Grass Bag

No Parts Required

#### Procedure

1. Slip the grass bag over the frame as shown in [Figure 9](#).

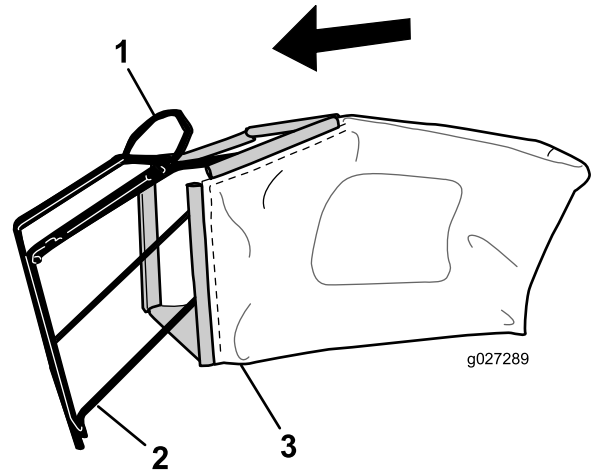
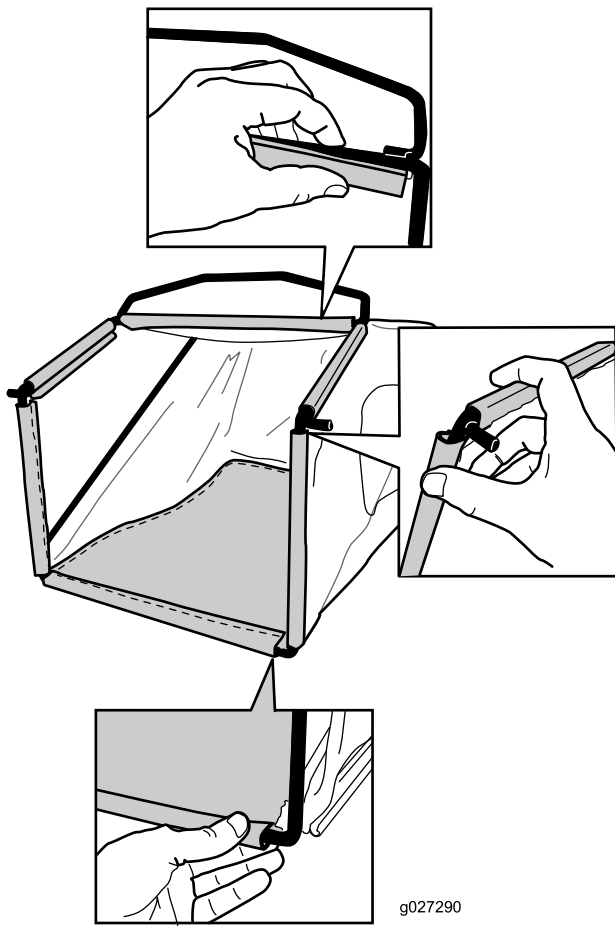

Figure 9

1. Handle
2. Frame
3. Grass bag

**Note:** Do not slip the bag over the handle ([Figure 9](#)).

2. Hook the bottom channel of the bag onto the bottom of the frame ([Figure 10](#)).



**Figure 10**

g027290

g027290

3. Hook the top and side channels of the bag onto the top and sides of the frame, respectively (Figure 10).

# Product Overview

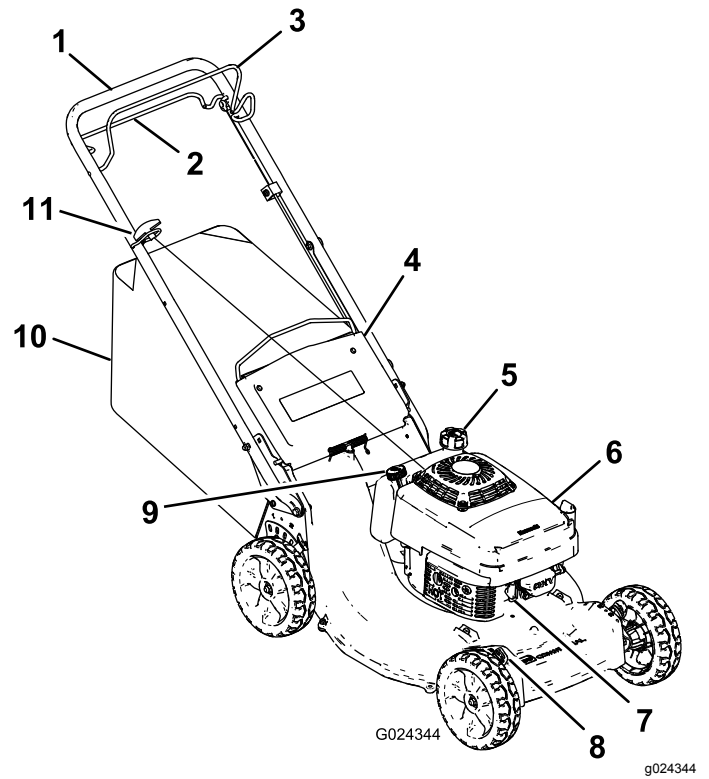

**Figure 11**

- |                          |                             |
|--------------------------|-----------------------------|
| 1. Handle                | 7. Spark plug               |
| 2. Self-propel-drive bar | 8. Cutting-height lever (4) |
| 3. Blade-control bar     | 9. Oil fill/dipstick        |
| 4. Rear door             | 10. Grass bag               |
| 5. Fuel-tank cap         | 11. Recoil-start handle     |
| 6. Air cleaner           |                             |

## Specifications

Model	Weight	Length	Width	Height
22291	56 kg (124 lb)	161 cm (64 inches)	55 cm (22 inches)	88 cm (35 inches)

# Operation

## Before Operation

### Before Operation Safety

#### General Safety

- Become familiar with the safe operation of the equipment, operator controls, and safety signs.
- Check that all guards and safety devices, such as deflectors and/or grass catcher, are in place and working properly.
- Always inspect the machine to ensure that the blades, blade bolts, and cutting assembly are not worn or damaged.
- Inspect the area where you will use the machine, and remove all objects that could interfere with the operation of the machine or that the machine could throw.
- Adjusting the cutting height may bring you into contact with the moving blade, causing serious injury.
  - Shut off the engine, remove the ignition key (electric-start model only), and wait for all moving parts to stop.
  - Do not put your fingers under the housing when adjusting the cutting height.

#### Fuel Safety

- Fuel is extremely flammable and highly explosive. A fire or explosion from fuel can burn you and others and can damage property.
  - To prevent a static charge from igniting the fuel, place the container and/or machine directly on the ground before filling, not in a vehicle or on an object.
  - Fill the fuel tank outdoors, in an open area, when the engine is cold. Wipe up any fuel that spills.
  - Do not handle fuel when smoking or around an open flame or sparks.
  - Do not remove the fuel cap or add fuel to the tank while the engine is running or hot.
  - If you spill fuel, do not attempt to start the engine. Avoid creating a source of ignition until the fuel vapors have dissipated.
  - Store fuel in an approved container and keep it out of the reach of children.
- Fuel is harmful or fatal if swallowed. Long-term exposure to vapors can cause serious injury and illness.

- Avoid prolonged breathing of vapors.
- Keep your hands and face away from the nozzle and the fuel-tank opening.
- Keep fuel away from your eyes and skin.

### Filling the Fuel Tank

#### **⚠ DANGER**

**Gasoline is extremely flammable and explosive. A fire or explosion from gasoline can burn you and others.**

- **To prevent a static charge from igniting the gasoline, place the container and/or machine directly on the ground before filling, not in a vehicle or on an object.**
- **Fill the tank outdoors when the engine is cold. Wipe up spills.**
- **Do not handle gasoline when smoking or around an open flame or sparks.**
- **Store gasoline in an approved fuel container, out of the reach of children.**
- For best results, use only clean, fresh (less than 30 days old), unleaded gasoline with an octane rating of 87 or higher ((R+M)/2 rating method).
- Oxygenated fuel with up to 10% ethanol or 15% MTBE by volume is acceptable.
- **Ethanol:** Gasoline with up to 10% ethanol (gasohol) or 15% MTBE (methyl tertiary butyl ether) by volume is acceptable. Ethanol and MTBE are not the same. Gasoline with 15% ethanol (E15) by volume is not approved for use. **Never use gasoline that contains more than 10% ethanol by volume**, such as E15 (contains 15% ethanol), E20 (contains 20% ethanol), or E85 (contains up to 85% ethanol). Using unapproved gasoline may cause performance problems and/or engine damage which may not be covered under warranty.
- **Do not** use gasoline containing methanol.
- **Do not** store fuel either in the fuel tank or in fuel containers over the winter unless you use a fuel stabilizer.
- **Do not** add oil to gasoline.

**Important:** To reduce starting problems, add fuel stabilizer to the gasoline all season. Mix the stabilizer with gasoline less than 30 days old.

**Note:** The capacity of the fuel tank is 1.8 L (0.47 US gallon).

# Checking the Engine-Oil Level

1. Move the machine to a level surface.
2. Remove the dipstick by rotating the cap counterclockwise and pulling it out (Figure 12).

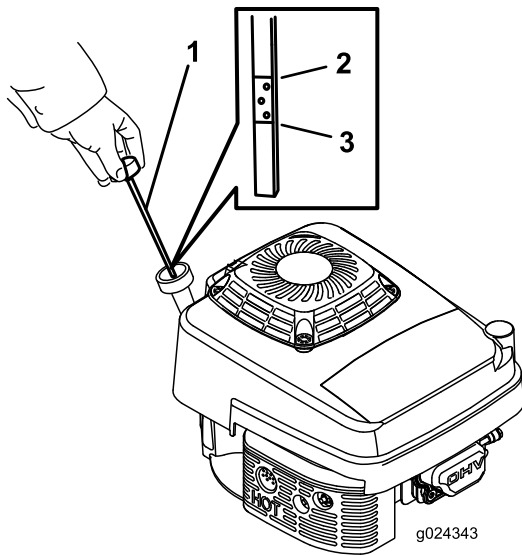

Figure 12

g024343

1. Dipstick
2. Full

3. Add

3. Wipe the dipstick clean with a clean cloth.
4. Insert the dipstick into the oil-fill tube, but do not screw it in, then remove the dipstick.
5. Read the oil level on the dipstick (Figure 12).
  - If the oil level on the dipstick is too low (Figure 12), carefully pour a small amount of SAE 30 or SAE 10W-30 detergent oil into the oil-fill tube, wait 3 minutes, and repeat steps 3 through 5 until the oil on the dipstick is at the correct level.
  - If the oil level on the dipstick is too high (Figure 12), drain the excess oil until the oil on the dipstick is at the correct level; refer to Changing the Engine Oil (page 19).

**Important:** If the oil level in the engine is too low or too high and you run the engine, you may damage the engine.

6. Install the dipstick into the oil-fill tube securely.

# Adjusting the Cutting Height

You can change the cutting height at each wheel by adjusting a cutting-height lever. Cutting heights are 25 mm (1 inch), 38 mm (1-1/2 inches), 51 mm (2 inches), 64 mm (2-1/2 inches), 76 mm (3 inches), 89 mm (3-1/2 inches), 102 mm (4 inches), 114 mm (4-1/2 inches).

## ⚠ DANGER

Adjusting the cutting-height levers could bring your hands into contact with a moving blade and result in serious injury.

- Shut off the engine and wait for all movement to stop before adjusting the cutting height.
- Do not put your fingers under the housing when adjusting the cutting height.

1. Pull the cutting-height lever toward the wheel (Figure 13) and move the lever to the desired setting.

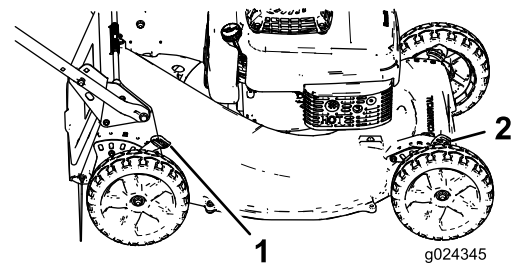

Figure 13

g024345

1. Rear cutting-height lever (2)
2. Front cutting-height lever (2)

2. Release the cutting-height lever and seat it securely in the notch.
3. Adjust all the wheels to the same cutting-height setting.

## During Operation

### During Operation Safety

#### General Safety

- Wear appropriate clothing, including eye protection; long pants; slip-resistant, substantial footwear; and hearing protection. Tie back long hair, secure loose clothing, and do not wear loose jewelry.
- Do not operate the machine while ill, tired, or under the influence of alcohol or drugs.

- The blade is sharp; contacting the blade can result in serious personal injury. Shut off the engine, remove the ignition key (electric-start model only), and wait for all moving parts to stop before leaving the operating position.
- When you release the blade-control bar, the engine should shut off and the blade should stop within 3 seconds. If not, stop using your machine immediately and contact an Authorized Service Dealer.
- Keep bystanders, especially small children, out of the operating area. Stop the machine if anyone enters the area.
- Always look down and behind you before moving the machine in reverse.
- Operate the machine only in good visibility and appropriate weather conditions. Do not operate the machine when there is the risk of lightning.
- Wet grass or leaves can cause serious injury if you slip and contact the blade. Avoid mowing in wet conditions.
- Use extreme care when approaching blind corners, shrubs, trees, or other objects that may block your view.
- Watch for holes, ruts, bumps, rocks, or other hidden objects. Uneven terrain could cause the machine to overturn or cause you to lose your balance or footing.
- If the machine strikes an object or starts to vibrate, immediately shut off the engine, remove the key (if equipped), wait for all moving parts to stop, and disconnect the wire from the spark plug before examining the machine for damage. Make all necessary repairs before resuming operation.
- Before leaving the operating position, shut off the engine, remove the ignition key (electric-start model only), and wait for all moving parts to stop.
- If the engine has been running the muffler will be hot and can severely burn you. Keep away from the hot muffler.
- Check the grass catcher components and the discharge chute frequently for any wear or deterioration and replace them with the manufacturer's recommended parts when necessary.
- Use accessories and attachments approved by The Toro® Company only.

## Slope Safety

- Mow across the face of slopes; never up and down. Use extreme caution when changing direction on slopes.

- Do not mow on excessively steep slopes. Poor footing could cause a slip-and-fall accident.
- Mow with caution near drop-offs, ditches, or embankments.

## Starting the Engine

1. Connect the spark-plug wire to the spark plug.
2. Firmly push in the primer (Figure 14), holding the primer bulb for 1 second.

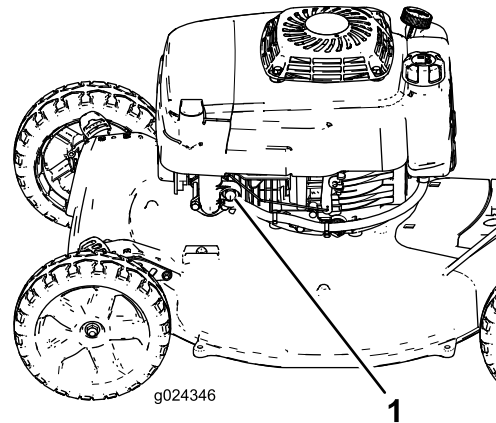

Figure 14

1. Primer

3. Pull the blade-control bar to the upper handle and hold it (Figure 15).

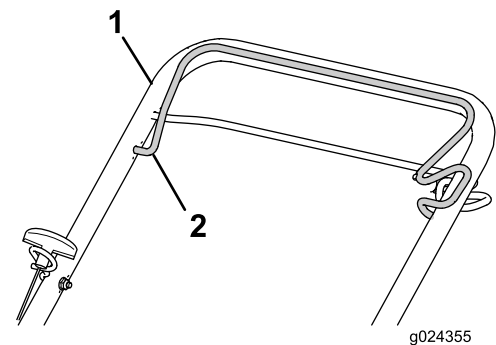

Figure 15

1. Upper handle
2. Blade-control bar

4. Pull the recoil-start handle lightly until you feel resistance, then pull it sharply, and allow it to return to the rope guide on the handle.

**Note:** If the engine does not start, repeat steps 2 through 4.

# Shutting Off the Engine

**Service Interval:** Before each use or daily—Ensure that the engine shuts off within 3 seconds after releasing the blade-control bar.

To shut off the engine, release the blade-control bar.

**Important:** When you release the blade-control bar, both the engine and blade should stop within 3 seconds. If they do not stop properly, stop using your machine immediately and contact an Authorized Service Dealer.

# Operating the Self-Propel Drive

- **To engage the self-propel-drive:** Pull the self-propel-drive bar to the handle and hold it (Figure 16).

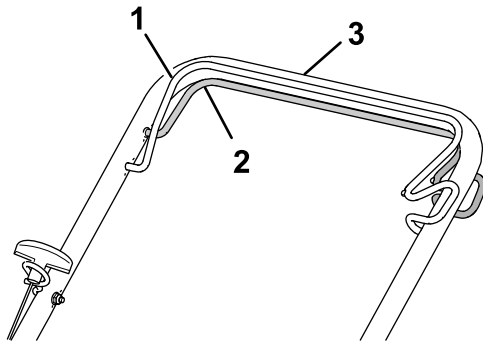

Figure 16

1. Blade-control bar (shown engaged)
2. Self-propel-drive bar
3. Upper handle

**Note:** The maximum self-propel-drive speed is fixed. To reduce the speed, increase the space between the self-propel-drive bar and the handle.

- **To disengage the self-propel drive:** Release the self-propel-drive bar.

**Note:** The machine comes with freewheeling clutches that make it easier to pull the machine rearward. To disengage the clutches, you may need to push the machine forward about 2.5 cm (1 inch) or more after you release the self-propel-drive bar.

# Recycling the Clippings

This machine comes from the factory ready to recycle grass and leaf clippings back into the lawn. To prepare the machine to recycle:

- If the grass bag is on the machine, remove it; refer to [Removing the Grass Bag \(page 15\)](#).
- If the rear-discharge plug is not installed, grip it by the handle, raise the rear deflector, and insert it into the rear-discharge chute until the latch locks into place (Figure 17).

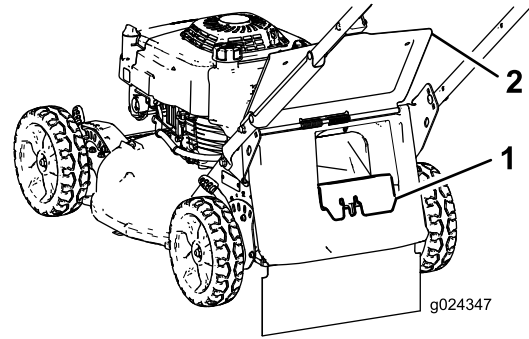

Figure 17

1. Rear-discharge plug
2. Rear deflector

## ⚠ WARNING

Operating the machine to recycle lawn clippings without the plug in place allows objects to be thrown toward you or bystanders. Also, contact with the blades could occur. Thrown objects or blade contact can cause serious injury or death.

Ensure that the rear-discharge plug is in place before you recycle the clippings. Never engage the blades without either the rear-discharge plug or the grass bag installed on the machine.



# Bagging the Clippings

Use the grass bag when you want to collect grass and leaf clippings from the lawn.

## ⚠ WARNING

A worn grass bag could allow small stones and other similar debris to be thrown toward you or bystanders, resulting in serious personal injury or death.

Check the grass bag frequently. If it is damaged, install a new Toro replacement bag.

## ⚠ WARNING

The blades are sharp; contacting the blades can result in serious personal injury.

Shut off the engine and wait for all moving parts to stop before leaving the operating position.

## Installing the Grass Bag

1. Shut off the engine and wait for all moving parts to stop.
2. Raise and hold up the rear deflector (Figure 18).

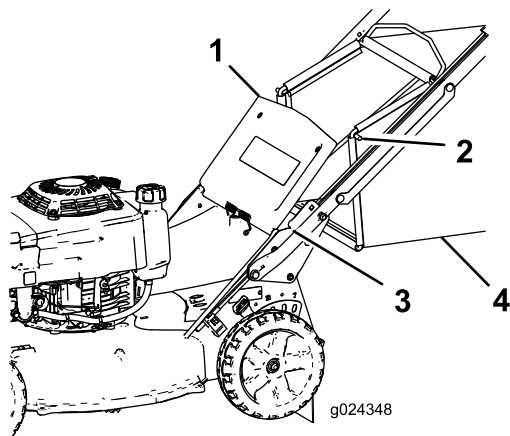

Figure 18

- |                    |              |
|--------------------|--------------|
| 1. Rear deflector  | 3. Notch (2) |
| 2. Bag-rod end (2) | 4. Grass bag |

3. Remove the rear-discharge plug by pushing in the latch with your thumb and pulling the plug out from the machine (Figure 17).
4. Install the bag-rod ends into the notches at the base of the handle, and rock the bag back and forth to ensure that the bag-rod ends are seated at the bottom of both notches (Figure 18).
5. Lower the rear deflector until it rests on the grass bag.

# Removing the Grass Bag

## ⚠ DANGER

The machine can throw grass clippings and other objects through an opening in the machine housing. Objects thrown with enough force could cause serious personal injury or death to you or to bystanders.

- Never remove the grass bag and then start the engine without the discharge plug installed on the machine.
  - Never open the rear deflector on the machine when the engine is running.
1. Shut off the engine and wait for all moving parts to stop.
  2. Raise the rear deflector.
  3. Remove the bag rod on the grass bag from the notches at the base of the handle (Figure 18).
  4. Install the discharge plug; refer to Recycling the Clippings (page 14).
  5. Lower the rear deflector.

## Operating Tips

### General Tips

- Review the safety instructions and read this manual carefully before operating the machine.
- Clear the area of sticks, stones, wire, branches, and other debris that the blade could hit and throw.
- Keep everyone, especially children and pets, away from the area of operation.
- Avoid striking trees, walls, curbs, or other solid objects. Never deliberately mow over any object.
- If the machine strikes an object or starts to vibrate, immediately shut off the engine, disconnect the wire from the spark plug, and examine the machine for damage.
- Maintain a **sharp blade** throughout the cutting season. Periodically file down nicks on the blade.
- Replace the blade when necessary with an original Toro replacement blade.
- Mow only dry grass or leaves. Wet grass and leaves tend to clump on the yard and can cause the machine to plug or the engine to stall.

## ⚠ WARNING

Wet grass or leaves can cause serious injury if you slip and contact the blade.

Mow only in dry conditions.

- Clean under the machine after each mowing; refer to [Cleaning under the Machine \(page 17\)](#).
- Keep the engine in good running condition.
- Clean the air filter frequently. Mulching stirs up more clippings and dust which clogs the air filter and reduces engine performance.
- Set the engine speed to the fastest position for the best cutting results.
- For light leaf coverage, set all the wheels at the same cutting-height setting.
- Slow down your mowing speed if the machine does not cut the leaves finely enough.

## **⚠ WARNING**

**Operating a machine with its engine running at a speed greater than the factory setting can cause the machine to throw a part of the blade or engine toward you or bystanders, resulting in serious personal injury or death.**

- **Do not change the engine speed setting.**
- **If you suspect the engine speed is faster than normal, contact an Authorized Service Dealer.**

## **Cutting Grass**

- Grass grows at different rates at different times of the year. In the summer heat, it is best to cut grass at the 64 mm (2-1/2 inch), 76 mm (3 inch), or 89 mm (3-1/2 inch) cutting-height settings. Cut only about a third of the grass blade at a time. Do not cut below the 64 mm (2-1/2 inch) setting unless the grass is sparse or it is late fall when grass growth begins to slow down.
- When cutting grass over 15 cm (6 inches) tall, first mow at the highest cutting-height setting and walk slower; then mow again at a lower setting for the best lawn appearance. If the grass is too long and the leaves clump on top of the lawn, the machine may plug and cause the engine to stall.
- Alternate the mowing direction. This helps disperse the clippings over the lawn for even fertilization.

If the finished lawn appearance is unsatisfactory, try 1 or more of the following:

- Sharpen the blade.
- Walk at a slower pace while mowing.
- Raise the cutting height on your machine.
- Cut the grass more frequently.
- Overlap cutting swaths instead of cutting a full swath with each pass.

## **Cutting Leaves**

- After cutting the lawn, ensure that half of the lawn shows through the cut leaf cover. You may need to make more than a single pass over the leaves.

# ***After Operation***

## **After Operation Safety**

### **General Safety**

- Clean grass and debris from the machine to help prevent fires. Clean up oil or fuel spills.
- Allow the engine to cool before storing the machine in any enclosure.
- Never store the machine or fuel container where there is an open flame, spark, or pilot light, such as on a water heater or on other appliances.

### **Hauling Safety**

- Remove the ignition key (if equipped) before loading the machine for hauling.
- Use care when loading or unloading the machine.
- Secure the machine from rolling.



# Cleaning under the Machine

To ensure the best performance, keep the underside of the machine clean. Be especially careful to keep the kickers free of debris (Figure 19).

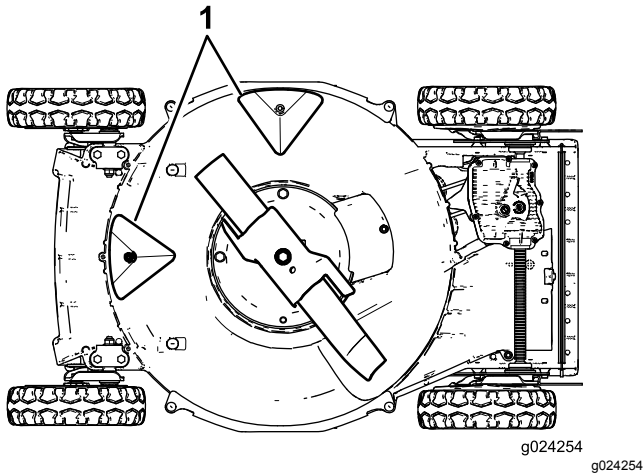

Figure 19

1. Kickers

## Washing Method

Service Interval: Before each use or daily

### ⚠ WARNING

The machine may dislodge material from under the machine.

- Wear eye protection.
  - Always wear gloves when working near the blade
  - Stay in the operating position (behind the handle) while the engine is running.
  - Do not allow bystanders in the area.
1. Move the machine to a paved level surface near a garden hose.
  2. Start the engine.
  3. Hold the running garden hose at handle level and direct the water to flow on the ground just in front of the right, rear wheel (Figure 20).

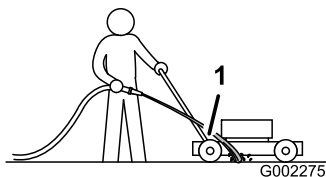

Figure 20

1. Right, rear wheel

**Note:** The blade will draw in water and wash out the clippings. Let the water run until you no longer see clippings being washed out from under the machine.

4. Shut off the engine and wait for all moving parts to stop.
5. Turn off the water.
6. Start the machine and let it run for a few minutes to dry out the underside of the machine.

## Scraping Method

If washing does not remove all debris from under the machine, scrape it clean.

1. Disconnect the wire from the spark plug.
2. Drain the fuel from the fuel tank.

### ⚠ WARNING

Tipping the machine may cause the fuel to leak from the carburetor or the fuel tank. Fuel is extremely flammable, highly explosive, and, under certain conditions, can cause personal injury or property damage.

Avoid fuel spills by running the engine dry or by removing the fuel with a hand pump; never siphon.

3. Tip the machine onto its **right** side (air cleaner up).
4. Remove the dirt and grass clippings with a hardwood scraper. Avoid burrs and sharp edges.
5. Return the machine to the operating position.
6. Connect the wire to the spark plug.

# Maintenance

## Recommended Maintenance Schedule(s)

Maintenance Service Interval	Maintenance Procedure
After the first 8 hours	<ul style="list-style-type: none"> <li>• Change the engine oil.</li> </ul>
After the first 25 hours	<ul style="list-style-type: none"> <li>• Tighten any loose fasteners.</li> </ul>
Before each use or daily	<ul style="list-style-type: none"> <li>• Ensure that the engine shuts off within 3 seconds after releasing the blade-control bar.</li> <li>• Remove grass clippings and dirt from under the machine.</li> <li>• Inspect the mower blades for wear or damage.</li> <li>• Inspect the accelerator for wear or damage.</li> <li>• Check the stopping time of the blade brake. The blade must stop within 3 seconds of releasing the blade-control bar; if it does not, contact an Authorized Service Dealer for repair.</li> <li>• Check for loose or missing fasteners on the engine.</li> <li>• Check for fuel or oil leaks.</li> <li>• Check or clean the recoil starter and the air-intake screen.</li> </ul>
Every 25 hours	<ul style="list-style-type: none"> <li>• Clean the foam pre-filter (more frequently in dusty conditions).</li> </ul>
Every 40 hours	<ul style="list-style-type: none"> <li>• Clean the wheels and gears.</li> </ul>
Every 50 hours	<ul style="list-style-type: none"> <li>• Change the engine oil (more frequently in dusty conditions).</li> <li>• Sharpen or replace the blade. Maintain it more frequently if the edge dulls quickly in rough or in sandy conditions.</li> <li>• Remove grass clippings and debris from under the belt cover.</li> </ul>
Every 100 hours	<ul style="list-style-type: none"> <li>• Inspect, clean, and adjust the spark plug gap; replace the spark plug if necessary.</li> <li>• Tighten any loose fasteners.</li> <li>• Check or clean the recoil starter and the air-intake screen.</li> </ul>
Every 200 hours	<ul style="list-style-type: none"> <li>• Have an authorized engine servicing dealer check for leaks in the fuel system and/or a deteriorating fuel hose. Replace parts if necessary.</li> </ul>
Every 300 hours	<ul style="list-style-type: none"> <li>• Replace the paper air filter (more frequently in dusty conditions).</li> <li>• Clean the cylinder and the cylinder-head fins.</li> <li>• Have an authorized engine servicing dealer check and adjust the engine idle speed.</li> <li>• Have an authorized engine servicing dealer clean the combustion chamber.</li> <li>• Have an authorized engine servicing dealer check and adjust the valve clearance.</li> <li>• Have an authorized engine servicing dealer clean and lap the valve seating surface.</li> </ul>

## Maintenance Safety

- Disconnect the spark-plug wire from the spark plug before performing any maintenance procedure.
- Wear gloves and eye protection when servicing the machine.
- The blade is sharp; contacting the blade can result in serious personal injury. Wear gloves when servicing the blade. Do not repair or alter the blade(s).
- Never tamper with safety devices. Check their proper operation regularly.
- Tipping the machine may cause the fuel to leak. Fuel is flammable and explosive, and can cause personal injury. Run the engine dry or remove the fuel with a hand pump; never siphon the fuel.
- To ensure optimum performance and continued safety certification of the machine, use only genuine Toro replacement parts and accessories. Replacement parts and accessories made by other manufacturers could be dangerous, and such use could void the product warranty.

# Servicing the Air Filter

**Service Interval:** Every 25 hours—Clean the foam pre-filter (more frequently in dusty conditions).

Every 300 hours—Replace the paper air filter (more frequently in dusty conditions).

**Important:** Do not operate the engine without the air filter assembly in place; otherwise, extreme engine damage will occur.

1. Shut off the engine and wait for all moving parts to stop.
2. Disconnect the wire from the spark plug.
3. Loosen the screw on the air-filter cover (Figure 21).

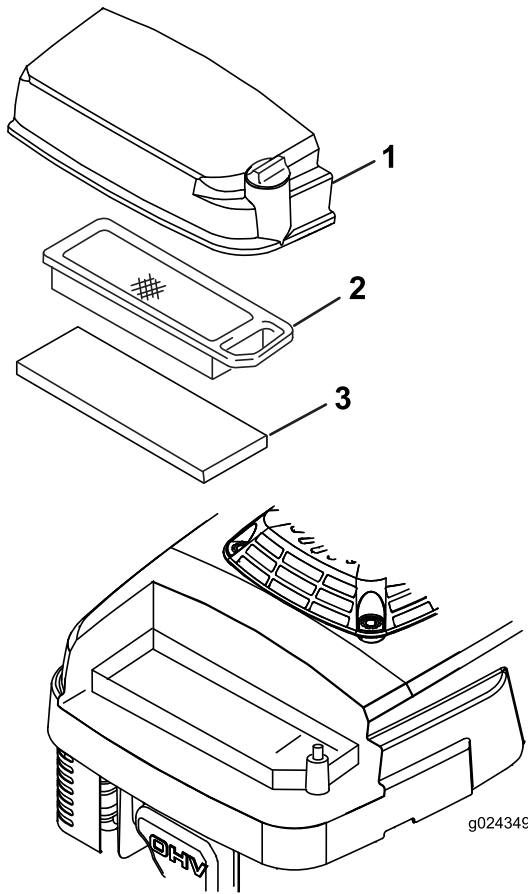

Figure 21

1. Air-filter cover
2. Paper air filter
3. Foam pre-filter

4. Remove the cover and clean it thoroughly.
5. Remove and inspect the paper air filter (Figure 21), and replace it if it is excessively dirty.

**Important:** Do not try to clean a paper filter.

6. Remove the foam pre-filter (Figure 21) and wash it with a mild detergent and water, then blot it dry.

7. Install the foam pre-filter.
8. Install the paper air filter.
9. Install the cover and secure it with the screw.

# Changing the Engine Oil

**Service Interval:** After the first 8 hours

Every 50 hours

Run the engine a few minutes before changing the oil to warm it. Warm oil flows better and carries more contaminants.

## Engine Oil Specifications

Engine oil capacity	0.65 L (22 fl oz)
Oil viscosity	SAE 30 or SAE 10W-30 detergent oil
API service classification	SJ or higher

1. Shut off the engine and wait for all moving parts to stop.
2. Disconnect the wire from the spark plug.
3. Drain the fuel from the fuel tank.
4. Place a suitable drain pan under the dipstick/oil drain.
5. Clean around the dipstick.
6. Remove the dipstick by rotating the cap counterclockwise and pulling it out.
7. Tip the machine onto its **right** side (air filter up) to drain the oil into the drain pan.
8. After draining the oil, return the machine to the operating position.
9. Fill the crankcase to the correct level on the dipstick with fresh oil; refer to [3 Filling the Crankcase with Oil \(page 8\)](#).
10. Insert the dipstick into the filler neck and rotate the cap clockwise until it is tight.
11. Wipe up any spilled oil.
12. Recycle the used oil according to local codes.

# Servicing the Spark Plug

**Service Interval:** Every 100 hours—Inspect, clean, and adjust the spark plug gap; replace the spark plug if necessary.

Use an **NGK BPR5ES** spark plug or equivalent.

1. Shut off the engine and wait for all moving parts to stop.
2. Disconnect the wire from the spark plug.
3. Clean around the spark plug.
4. Remove the spark plug from the cylinder head.

**Important:** Replace a cracked, fouled, or dirty spark plug. Do not clean the electrodes because grit entering the cylinder can damage the engine.

5. Set the gap on the plug to 0.76 mm (0.030 inch); refer to [Figure 22](#).

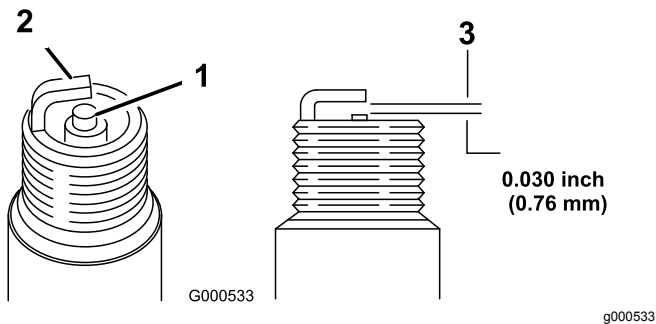

**Figure 22**

1. Center-electrode insulator
2. Side electrode
3. Air gap (not to scale)

6. Carefully install the spark plug by hand (to avoid cross threading) until it is hand tight.
7. Tighten the spark plug to 23 N·m (2.3 kgf·m, 17 ft·lb).

**Important:** A loose spark plug can become very hot and can damage the engine; overtightening a spark plug may damage the threads in the cylinder head.

8. Connect the wire to the spark plug.

# Adjusting the Self-Propel Drive

If the machine is new, does not self-propel, or it tends to creep forward, adjust the drive cable.

1. Move the machine outside and onto a paved surface near a solid wall to safely prevent the

machine from moving forward while the engine is running.

2. Position the machine with the front tires against the wall.

**Note:** Ensure that the area is well ventilated and clear of debris that could be thrown by the machine.

3. Shift the transmission to third gear.
4. Start the engine; refer to [Starting the Engine \(page 13\)](#).

5. Pull the self-propel-drive bar to the handle.

**Note:** The wheels should start to turn as the self-propel-drive bar just touches the handle.

6. Shut off the engine.
7. If you must adjust the machine, do the following:
  - If the wheels do not spin when you engage the self-propel-drive bar, the traction belt is too loose. Rotate the wheel-drive-control knob ([Figure 23](#)) clockwise 1 turn and repeat steps 4 through 6.

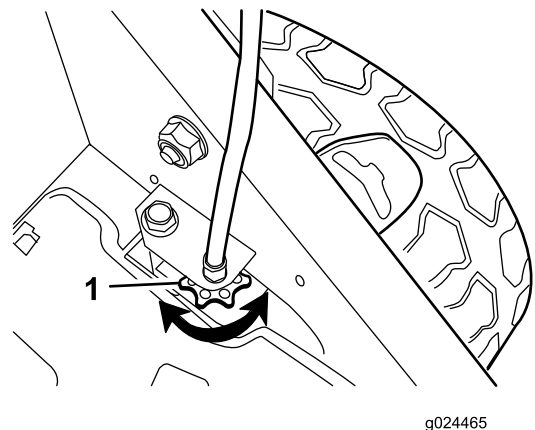

**Figure 23**

1. Wheel-drive-control knob

- If the wheels spin before you fully engage the self-propel-drive bar, the traction belt is too tight. Rotate the wheel-drive-control knob ([Figure 23](#)) counterclockwise 1 turn and repeat steps 4 through 6.

8. For a new traction belt, rotate the drive-cable-adjustment knob clockwise 1 additional turn to allow for the normal stretching of the belt during the break-in period.

**Note:** You can skip this step if you are adjusting a used belt.

# Maintaining the Blade

Always mow with a sharp blade. A sharp blade cuts cleanly and without tearing or shredding the grass blades.

## Preparing the Machine

1. Shut off the engine and wait for all moving parts to stop.
2. Disconnect the wire from the spark plug.
3. Drain the fuel from the fuel tank.
4. Tip the machine onto its **right** side (air cleaner up) as shown in [Figure 24](#).

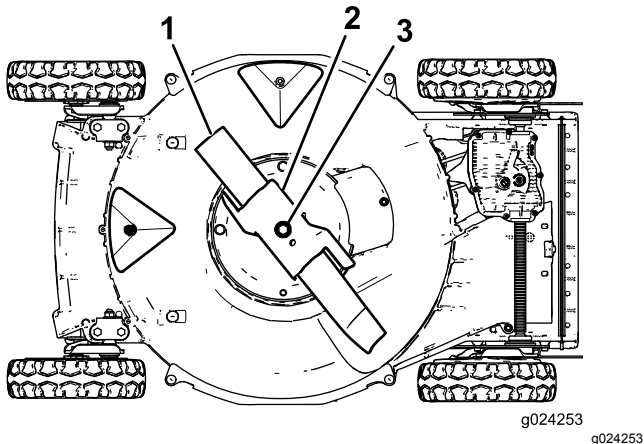

**Figure 24**

- |                |                               |
|----------------|-------------------------------|
| 1. Blade       | 3. Blade bolt and lock washer |
| 2. Accelerator |                               |

## Inspecting the Blade

**Service Interval:** Before each use or daily—Inspect the mower blades for wear or damage.

Carefully examine the blade for sharpness and wear, especially where the flat and the curved parts meet ([Figure 25A](#)). Because sand and abrasive material can wear away the metal that connects the flat and curved parts of the blade, check the blade before using the machine. If you notice a slot or wear ([Figure 25B](#) and [Figure 25C](#)), replace the blade; refer to [Removing the Blade](#) (page 22).

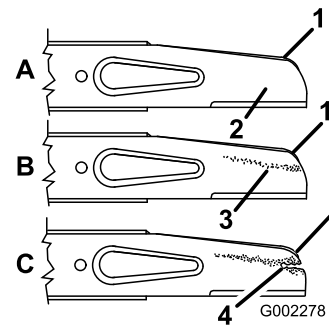

**Figure 25**

- |                           |                |
|---------------------------|----------------|
| 1. Sail                   | 3. Wear        |
| 2. Flat part of the blade | 4. Slot formed |

**Note:** For the best performance, install a new blade before the mowing season begins. During the year, file down any small nicks to maintain the cutting edge.

### **⚠ DANGER**

A worn or damaged blade can break, and a piece of the blade could be thrown toward you or bystanders, resulting in serious personal injury or death.

- Inspect the blade periodically for wear or damage.
- Replace a worn or damaged blade.

## Inspecting the Accelerator

**Service Interval:** Before each use or daily—Inspect the accelerator for wear or damage.

Carefully examine the accelerator for excessive wear ([Figure 26](#)). Because sand and abrasive material can wear away the metal (especially in the area shown as item 2 in [Figure 26](#)), check the accelerator before using the machine. If you notice that a tab on the accelerator has been worn down to a sharp edge or there is a crack, replace the accelerator; refer to [Removing the Blade](#) (page 22).

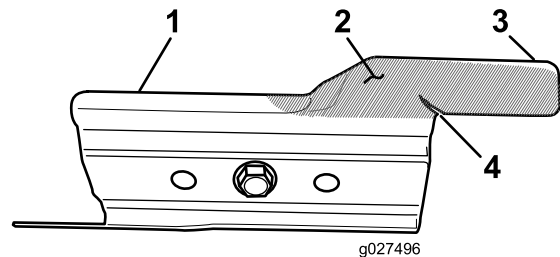

**Figure 26**

- |                |                 |
|----------------|-----------------|
| 1. Accelerator | 3. Tab          |
| 2. Wear area   | 4. Crack formed |

## ⚠ WARNING

A worn or damaged accelerator can break, and a piece of the accelerator could be thrown toward you or bystanders, resulting in serious personal injury or death.

- Inspect the accelerator periodically for wear or damage.
- Replace a worn or damaged accelerator.

## Removing the Blade

1. Grasp the end of the blade using a rag or a thickly padded glove.
2. Remove the blade nuts, the accelerator, and the blade (Figure 25).

## Sharpening the Blade

**Service Interval:** Every 50 hours—Sharpen or replace the blade. Maintain it more frequently if the edge dulls quickly in rough or in sandy conditions.

File the top side of the blade to maintain its original cutting angle (Figure 27A) and inner cutting edge radius (Figure 27B). The blade will remain balanced if you remove the same amount of material from both cutting edges.

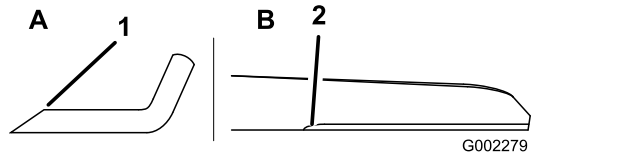

Figure 27

1. Sharpen the blade at this angle only.
2. Maintain the original radius here.

## Balancing the Blade

1. Check the balance of the blade by placing the center hole of the blade over a nail or screwdriver shank clamped horizontally in a vise (Figure 28).

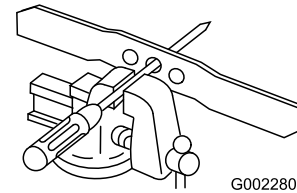

Figure 28

**Note:** You can also check the balance using a commercially manufactured blade balancer.

2. If either end of the blade rotates downward, file that end (not the cutting edge or the end near the cutting edge) until neither end of the blade drops.

## Installing the Blade

1. Install a sharp, balanced Toro blade, the accelerator, and the blade nuts. The sail of the blade must point toward the top of the mower housing for proper installation.

**Note:** Torque the blade nuts to 20 to 37 N·m (15 to 27 ft·lb).

## ⚠ WARNING

Operating the machine without the accelerator in place can cause the blade to flex, bend, or break, resulting in serious injury or death to you or to bystanders.

**Do not operate the machine without the accelerator in place.**

2. Return the machine to the operating position.

## Cleaning under the Belt Cover

**Service Interval:** Every 50 hours—Remove grass clippings and debris from under the belt cover.

1. Shut off the engine and wait for all moving parts to stop.
2. Disconnect the wire from the spark plug.
3. Remove the belt cover (Figure 29) from the mower housing.

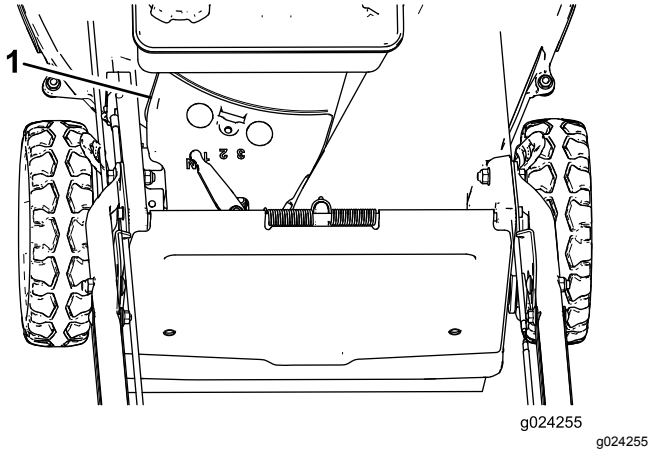

Figure 29

1. Belt cover
- 
4. Lift off the cover and brush out all the debris around the belt area.
  5. Install the belt cover.
  6. Connect the wire to the spark plug.

## Cleaning the Wheels

**Service Interval:** Every 40 hours

**Important:** To prevent damage to the bearing seals, do not use a high-pressure water spray on the bearings.

**Note:** If you operate the machine in extreme conditions, cleaning the wheels more frequently than recommended will increase gear life.

1. Remove the flange lock nut and wheel assembly from the axle bolt (Figure 30).
2. Clean any debris from the wheel-gear area (Figure 30).

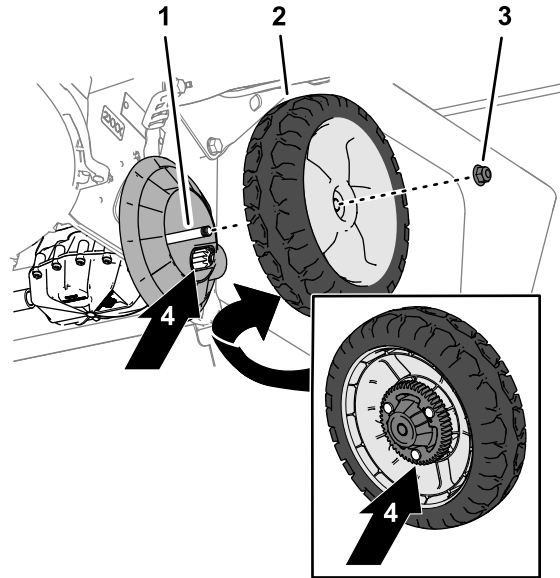

Figure 30

1. Axle bolt
2. Wheel assembly
3. Flange lock nut
4. Gears

- 
3. After cleaning, apply a small amount of anti-seize compound to the gears (Figure 30).
  4. Assemble the wheel assembly to the axle bolt with the flange lock nut (Figure 30).



# Storage

To prepare the machine for off-season storage, perform the recommended maintenance procedures; refer to [Storage \(page 24\)](#).

Store the machine in a cool, clean, dry place. Cover the machine to keep it clean and protected.

## Preparing the Fuel System

Empty the fuel from the fuel tank when mowing for the last time before storing the machine.

1. Run the engine until it shuts off from running out of fuel.
2. Choke the engine and start it again.
3. Allow the engine to run until it shuts off. When you can no longer start the engine, it is sufficiently dry.

## Preparing the Engine

1. While the engine is still warm, change the oil in the crankcase; refer to [Changing the Engine Oil \(page 19\)](#).
2. Remove the spark plug.
3. Using an oil can, add about 30 ml (1 fl oz) of engine oil to the engine crankcase through the spark-plug hole.
4. Slowly rotate the engine several times by pulling the recoil-start handle to distribute the oil throughout the engine crankcase.
5. Install the spark plug but **do not** connect the wire to the spark plug.

## General Information

1. Clean under the machine; refer to [Cleaning under the Machine \(page 17\)](#).
2. Clean any dirt and chaff from the cylinder, cylinder head fins, and blower housing.
3. Remove grass clippings, dirt, and grime from the external parts of the engine, the shrouding, and the top of the mower housing.
4. Check the condition of the blade; refer to [Inspecting the Blade \(page 21\)](#).
5. Check the condition of the accelerator; refer to [Inspecting the Accelerator \(page 21\)](#).
6. Service the air filter; refer to [Servicing the Air Filter \(page 19\)](#).
7. Tighten all nuts, bolts, and screws.

8. Touch up all rusted or chipped paint surfaces with paint available from an Authorized Service Dealer.

## Removing the Machine from Storage

1. Check and tighten all fasteners.
2. Remove the spark plug and spin the engine rapidly using the starter to blow out the excess oil from the cylinder.
3. Clean the spark plug or replace it if it is cracked, broken, or if the electrodes are worn.
4. Install the spark plug; refer to [Servicing the Spark Plug \(page 20\)](#).
5. Perform any needed maintenance procedures; refer to [Maintenance \(page 18\)](#).
6. Fill the fuel in the fuel tank with fresh fuel.
7. Check the engine-oil level.
8. Connect the wire to the spark plug.



# Troubleshooting

Problem	Possible Cause	Corrective Action
The engine does not start.	<ol style="list-style-type: none"> <li>1. The fuel tank is empty or the fuel system contains stale fuel.</li> <li>2. The throttle lever is not in the CHOKE position.</li> <li>3. The wire is not connected to the spark plug.</li> <li>4. The spark plug is pitted, fouled, or the gap is incorrect.</li> </ol>	<ol style="list-style-type: none"> <li>1. Drain and/or fill the fuel tank with fresh fuel. If the problem persists, contact an Authorized Service Dealer.</li> <li>2. Move the throttle lever to the CHOKE position.</li> <li>3. Connect the wire to the spark plug.</li> <li>4. Check the spark plug and adjust the gap if necessary. Replace the spark plug if it is pitted, fouled, or cracked.</li> </ol>
The engine starts hard or loses power.	<ol style="list-style-type: none"> <li>1. The fuel tank contains stale fuel.</li> <li>2. The air-filter element is dirty and is restricting the air flow.</li> <li>3. The underside of the machine contains clippings and debris.</li> <li>4. The spark plug is pitted, fouled, or the gap is incorrect.</li> <li>5. The engine-oil level is low or the oil is dirty.</li> </ol>	<ol style="list-style-type: none"> <li>1. Drain and fill the fuel tank with fresh fuel.</li> <li>2. Clean the air-filter pre-cleaner and/or replace the paper air filter.</li> <li>3. Clean the underside of the machine.</li> <li>4. Check the spark plug and adjust the gap if necessary. Replace the spark plug if it is pitted, fouled, or cracked.</li> <li>5. Check the engine oil. Change the oil if it is dirty or add oil if it is low.</li> </ol>
The engine runs rough.	<ol style="list-style-type: none"> <li>1. The wire is not connected to the spark plug.</li> <li>2. The spark plug is pitted, fouled, or the gap is incorrect.</li> <li>3. The throttle lever is not in the FAST position.</li> <li>4. The air-filter element is dirty and is restricting the air flow.</li> </ol>	<ol style="list-style-type: none"> <li>1. Connect the wire to the spark plug.</li> <li>2. Check the spark plug and adjust the gap if necessary. Replace the spark plug if it is pitted, fouled, or cracked.</li> <li>3. Move the throttle lever to the FAST position.</li> <li>4. Clean the air-filter pre-cleaner and/or replace the paper air filter.</li> </ol>
The machine or engine vibrates excessively.	<ol style="list-style-type: none"> <li>1. The blade is bent or is out of balance.</li> <li>2. The blade mounting nuts are loose.</li> <li>3. The underside of the machine contains clippings and debris.</li> <li>4. The engine mounting bolts are loose.</li> </ol>	<ol style="list-style-type: none"> <li>1. Balance the blade. If the blade is bent, replace it.</li> <li>2. Tighten the blade mounting nuts.</li> <li>3. Clean the underside of the machine.</li> <li>4. Tighten the engine mounting bolts.</li> </ol>
The cutting pattern is uneven.	<ol style="list-style-type: none"> <li>1. All 4 wheels are not at the same height.</li> <li>2. The blade is dull.</li> <li>3. You are mowing in the same pattern repeatedly.</li> <li>4. The underside of the machine contains clippings and debris.</li> </ol>	<ol style="list-style-type: none"> <li>1. Place all 4 wheels at the same height.</li> <li>2. Sharpen and balance the blade.</li> <li>3. Change the mowing pattern.</li> <li>4. Clean the underside of the machine.</li> </ol>
The discharge chute plugs up.	<ol style="list-style-type: none"> <li>1. The throttle lever is not in the FAST position.</li> <li>2. The cutting height is too low.</li> <li>3. You are mowing too fast.</li> <li>4. The grass is wet.</li> <li>5. The underside of the machine contains clippings and debris.</li> </ol>	<ol style="list-style-type: none"> <li>1. Move the throttle lever to the FAST position.</li> <li>2. Raise the cutting height.</li> <li>3. Slow down.</li> <li>4. Allow the grass to dry before mowing.</li> <li>5. Clean the underside of the machine.</li> </ol>
The machine does not self-propel.	<ol style="list-style-type: none"> <li>1. The self-propel drive cable is out of adjustment or is damaged.</li> <li>2. There is debris under the belt cover.</li> </ol>	<ol style="list-style-type: none"> <li>1. Adjust the self-propel drive cable. Replace the cable if necessary.</li> <li>2. Clean the debris from under the belt cover.</li> </ol>

**Notes:**

**Notes:**

## **European Privacy Notice**

### **The Information Toro Collects**

Toro Warranty Company (Toro) respects your privacy. In order to process your warranty claim and contact you in the event of a product recall, we ask you to share certain personal information with us, either directly or through your local Toro company or dealer.

The Toro warranty system is hosted on servers located within the United States where privacy law may not provide the same protection as applies in your country.

**BY SHARING YOUR PERSONAL INFORMATION WITH US, YOU ARE CONSENTING TO THE PROCESSING OF YOUR PERSONAL INFORMATION AS DESCRIBED IN THIS PRIVACY NOTICE.**

### **The Way Toro Uses Information**

Toro may use your personal information to process warranty claims, to contact you in the event of a product recall and for any other purpose which we tell you about. Toro may share your information with Toro's affiliates, dealers or other business partners in connection with any of these activities. We will not sell your personal information to any other company. We reserve the right to disclose personal information in order to comply with applicable laws and with requests by the appropriate authorities, to operate our systems properly or for our own protection or that of other users.

### **Retention of your Personal Information**

We will keep your personal information as long as we need it for the purposes for which it was originally collected or for other legitimate purposes (such as regulatory compliance), or as required by applicable law.

### **Toro's Commitment to Security of Your Personal Information**

We take reasonable precautions in order to protect the security of your personal information. We also take steps to maintain the accuracy and current status of personal information.

### **Access and Correction of your Personal Information**

If you would like to review or correct your personal information, please contact us by email at [legal@toro.com](mailto:legal@toro.com).

## **Australian Consumer Law**

Australian customers will find details relating to the Australian Consumer Law either inside the box or at your local Toro Dealer.