



ProLine

44" Mower

for 120 Traction Unit

Model No. 30546- 990001 & Up

Operator's Manual

IMPORTANT: Read this manual carefully. It contains information about your safety and the safety of others. Also become familiar with the controls and their proper use before you operate the product.

Introduction

We want you to be completely satisfied with your new product, so feel free to contact your local Authorized Service Dealer for help with service, genuine replacement parts, or other information you may require.

Whenever you contact your Authorized Service Dealer or the factory, always know the model and serial numbers of your product. These numbers will help the Service Dealer or Service Representative provide exact information about your specific product. You will find the model and serial number plate located in a unique place on the product as shown below.

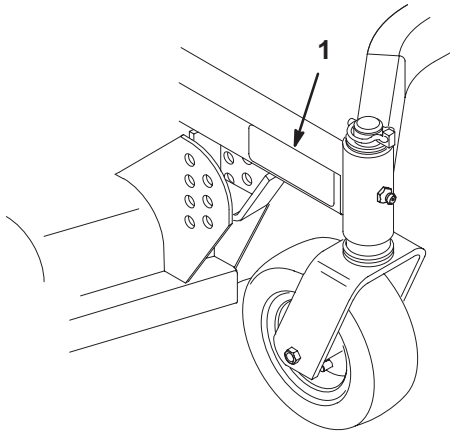

m-3151

1. Model and Serial Number Plate

For your convenience, write the product model and serial numbers in the space below.

Model No: _____
Serial No. _____

The warning system in this manual identifies potential hazards and has special safety messages that help you and others avoid personal injury, even death. DANGER, WARNING and CAUTION are signal words used to identify the level of hazard. However, regardless of the hazard, be extremely careful.

DANGER signals an extreme hazard that will cause serious injury or death if the recommended precautions are not followed.

WARNING signals a hazard that may cause serious injury or death if the recommended precautions are not followed.

CAUTION signals a hazard that may cause minor or moderate injury if the recommended precautions are not followed.

Two other words are also used to highlight information. “Important” calls attention to special mechanical information and “Note” emphasizes general information worthy of special attention.

The left and right side of the machine is determined by sitting on the seat in the normal operator’s position.

Contents

	Page		Page
Safety and Instruction Decals	2	Correcting Cutting Unit Mismatch	10
Installation	3	Setting the Front-to-Rear Pitch	10
Loose Parts	3	Setting the Side-to-Side Leveling	11
Installing the Castor Wheels	4	Greasing and Lubrication	12
Installing the Carrier Frame to the Traction Unit	4	Replacing the Deck Belt	13
Installing the Cutting Deck	5	Replacing the Drive Belt	13
Installing the Drive Belt	5	Replacing Spindle and Bearings	14
Operation	6	Removing the Right Side Recycler [®] Baffle for Discharge Mowing	15
Operating the Power Take Off (PTO)	6	Replacing the Castor Wheel Fork Bushings	16
Implement Lift Lever	6	Servicing the Castor Wheels and Bearings	17
Maintenance	7	Replacing the Grass Deflector	18
Service Interval Chart	7	Storage	18
Cutting Blades	7	Troubleshooting	19

Safety and Instruction Decals



Safety decals and instructions are easily visible to the operator and are located near any area of potential danger. Replace any decal that is damaged or lost.

**ON BOTH SIDES OF CUTTING UNIT
(Part No. 93-7316)**

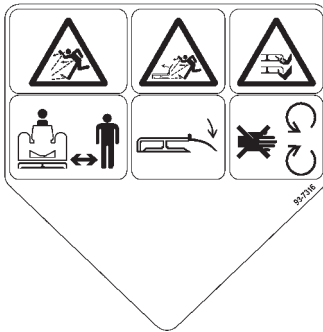

**ON FRONT OF CUTTING UNIT
(Part No. 93-7824)**



**ON LEFT, CENTER AND RIGHT SIDES
OF DECK, UNDER SHIELDS
(Part No. 93-7273)**



**UNDER DEFLECTOR
(Part No. 93-7828)**



**ON SIDES OF CUTTING UNIT
(Part No. 93-7819)**

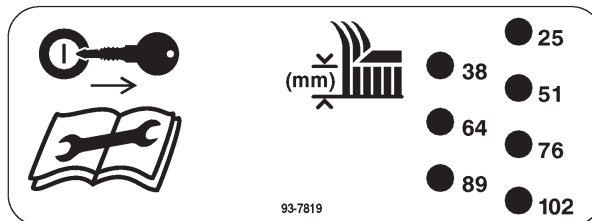

Installation

Loose Parts

Note: Use the chart below to identify parts used for assembly.

DESCRIPTION	QTY.	USE
Castor Wheel Assembly	2	Install castor wheels to carrier frame
Thrust Washer	8	
Lynch Pin	2	
Carrier Frame	1	Install carrier frame to traction unit
Bolt 3/8"-16 x 1-3/4" (45 mm)	6	
Locknut, 3/8"-16	6	
Bolt 3/8"-16 x 7/8" (22 mm)	4	
Shim	2	
Clevis Pin	4	Install cutting unit to carrier frame
Hairpin Cotter	4	
Operator's Manual	1	Read before operating
Parts Catalog	1	Ordering parts

Installing the Castor Wheels

1. Place a thrust washer onto the castor wheel fork (Fig. 1).
2. Insert the castor wheel fork into the carrier frame mounting tube (Fig. 1).
3. Install two (2) thrust washers onto the castor wheel fork, then secure with lynch pin (Fig. 1).

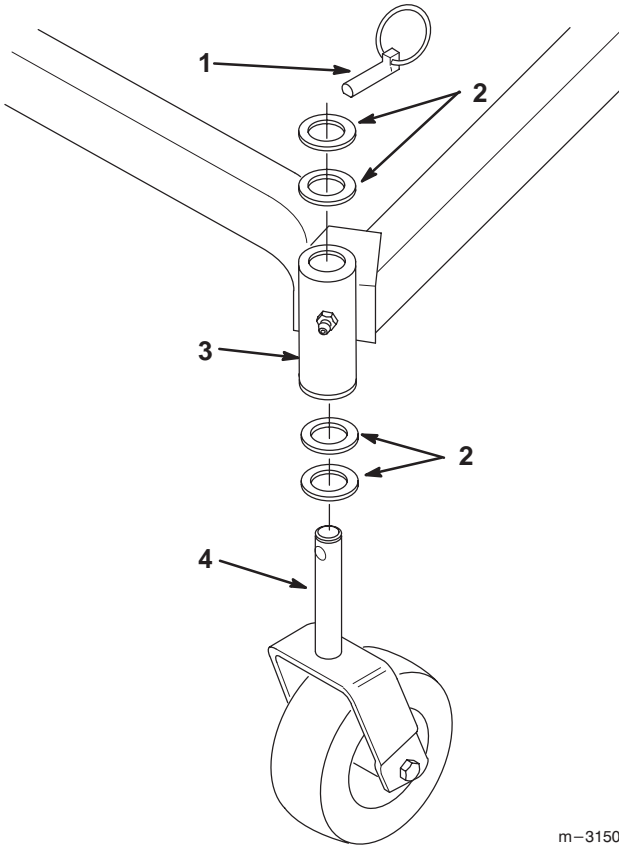

Figure 1

- | | |
|----------------------|--------------------------------|
| 1. Lynch Pin | 3. Carrier Frame Mounting Tube |
| 2. Thrust Washer (4) | 4. Castor Wheel Fork |

Installing the Carrier Frame to the Traction Unit

1. Place shims on top of traction unit lift arms. Align the carrier frame holes with the mounting holes in the traction unit lift arms (Fig. 2).
2. Fasten each side of the carrier frame to the traction unit lift arms with (2) 3/8"- 7/8" (22 mm) bolts from the top and (2) 3/8"- 1-3/4" (45 mm) bolts and 3/8" locknuts from the side (Fig. 2).
3. Torque the mounting screws to 60–80 ft-lb (81–109 N•m).

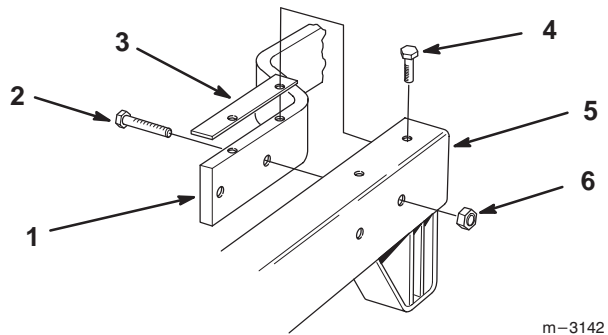

Figure 2

- | | |
|-----------------------------|---------------------------|
| 1. Traction Unit Frame | 4. Bolt 3/8"-7/8" (22 mm) |
| 2. Bolt 3/8"-1-3/4" (45 mm) | 5. Carrier Frame |
| 3. Shim | 6. Locknut 3/8" |

4. Set the castor wheel tire pressure to 25–30 psi (172–207 kPa).

Installing the Cutting Deck

1. Position the cutting deck under the carrier frame.
2. Mount the cutting deck to the carrier frame with four (4) clevis pins and hairpin cotters (Fig. 3).

Note: All four pins must be in the same hole locations to prevent uneven cutting.

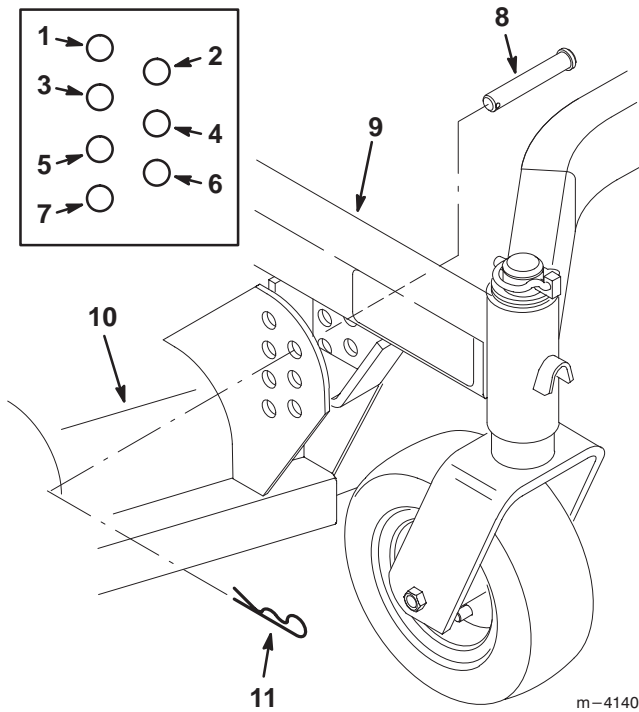

Figure 3

- | | |
|------------------------------|---------------------------|
| 1. 1" (25 mm) Cut Height | 7. 4" (102 mm) Cut Height |
| 2. 1-1/2" (38 mm) Cut Height | 8. Clevis Pin |
| 3. 2" (51 mm) Cut Height | 9. Carrier Frame |
| 4. 2-1/2" (64 mm) Cut Height | 10. Cutting Deck |
| 5. 3" (76 mm) Cut Height | 11. Hairpin Cotter |
| 6. 3-1/2" (89 mm) Cut Height | |

Installing the Drive Belt

1. Remove wing studs holding belt cover to the top of the cutting unit and remove belt cover.
2. Install the drive belt around the drive pulley on the traction unit, lift up on the idler and place belt around gearbox pulley (Fig. 4).
3. Install the belt cover onto the cutting unit.

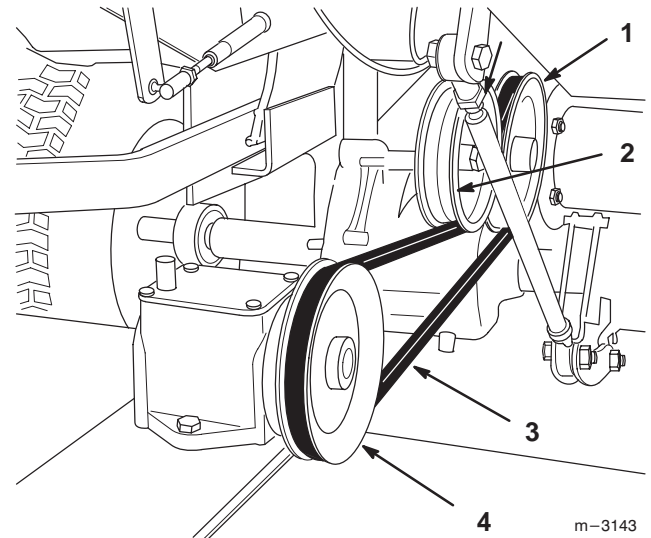

Figure 4

- | | |
|-------------------------------|-------------------|
| 1. Traction Unit Drive Pulley | 3. Drive Belt |
| 2. Idler Pulley | 4. Gearbox Pulley |

Operation

Operating the Power Take Off (PTO)

The power take off (PTO) switch engages and disengages power to the electric clutch.

Engaging the PTO

1. Release the parking brake.
2. Release pressure on the traction pedal to stop movement.
3. To engage lift cover and move the PTO switch to the “ON” position (Fig. 5).

Disengaging the PTO

1. Closing the cover moves the PTO switch to the “OFF” position (Fig. 5).

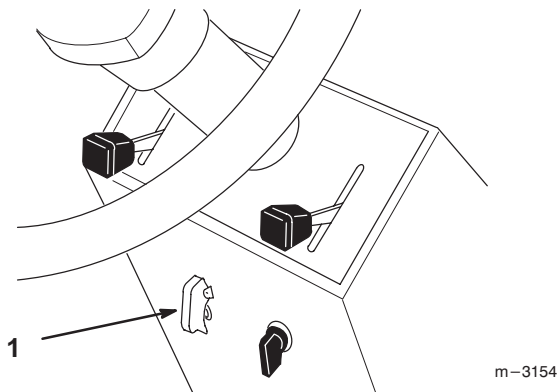

Figure 5

1. PTO switch

Implement Lift Lever

The implement lift lever (Fig. 6) is used to raise and lower various attachments.

Raising Attachments

1. Remove pressure from traction pedal to stop the machine.
2. Pull implement lift lever (Fig. 6) rearward to raise attachment to the desired height.

Lowering Attachments

1. Remove pressure from traction pedal to stop the machine.
2. Push implement lift lever (Fig. 6) forward to lower attachment.

Note: Hold lift lever in down position 1–2 seconds after attachment in down to extend lift cylinder allowing attachment to float with changes in ground contour.

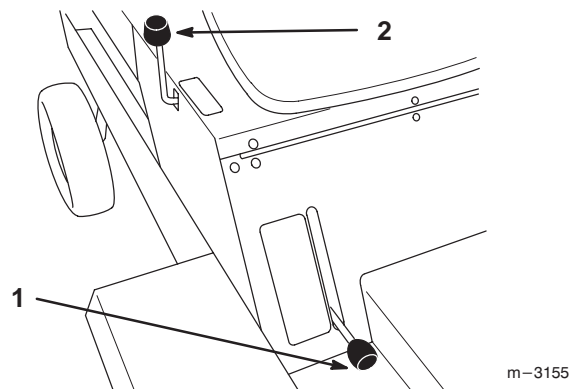

Figure 6

1. Parking brake
2. Implement lift lever

Maintenance

Service Interval Chart

Service Operation	Each Use	8 Hours	25 Hours	Storage Service	Notes
Cutting Blades – check		X		X	
Belts – check for wear/cracks				X	
Blade Spindle Bearings – grease		X			
Idler Arm – grease			X		
Castor Wheels – grease			X		
Mower Housing – clean	X	X		X	
Chipped Surfaces – paint				X	

Cutting Blades

To ensure a superior quality of cut, keep the blades sharp. For convenient sharpening and replacement, you may want to keep extra blades on hand.

WARNING

POTENTIAL HAZARD

- A blade that is worn or damaged could break apart and pieces could be thrown at bystanders or at you as you use the mower.

WHAT CAN HAPPEN

- Pieces of blade that may be thrown could seriously injure or kill you or bystanders.

HOW TO AVOID THE HAZARD

- Periodically inspect the blade for wear and damage. Immediately install a new blade if it is worn or damaged.

Before Inspecting or Servicing the Blades

Park the machine on a level surface, disengage the blade control (PTO) and set the parking brake. Turn the ignition key to “OFF” to stop the engine. Remove the key and disconnect the spark plug wire(s) from the spark plug(s).

Inspecting the Blades

1. Inspect the cutting edges (Fig 7). If the edges are not sharp or have nicks, remove and sharpen the blades. Refer to Sharpening the Blades on page 9.
2. Inspect the blades, especially the curved area (Fig. 7). If you notice any damage, wear, or a slot forming in this area (item 3 in Fig. 7), immediately install a new blade.

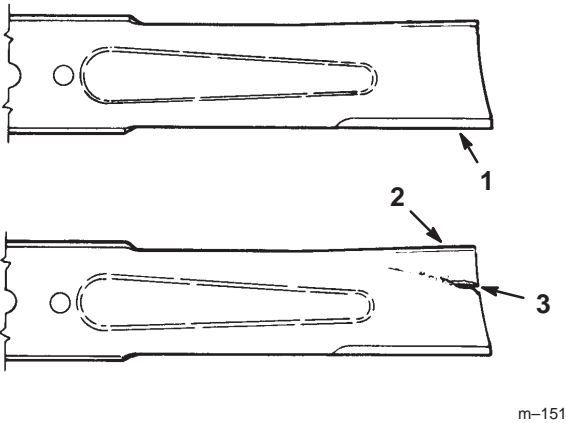

Figure 7

1. Cutting Edge
2. Curved Area
3. Wear/slot Forming

m-151

Checking for Bent Blades

1. Rotate the blades until the ends face forward and backward (Fig. 8). Measure from a level surface to the cutting edge of the blades (Fig. 9). Note this dimension.

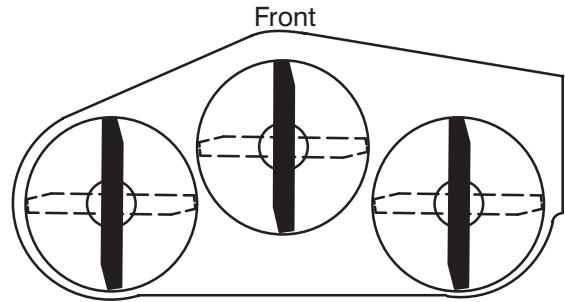

m-1078

Figure 8

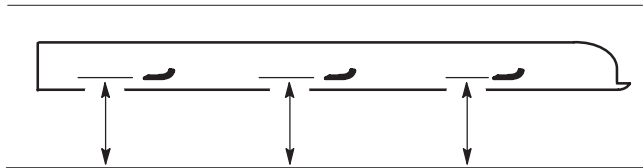

MEASURE FROM
CUTTING EDGE TO A
LEVEL SURFACE

m-2539

Figure 9

2. Rotate the opposite ends of the blades forward. Measure from a level surface to the cutting edge of the blades at the same position as in step 1 above. The difference between the dimensions obtained in steps 1 and 2 must not exceed 1/8" (3 mm). If this dimension exceeds 1/8" (3 mm), the blade is bent and must be replaced. Refer to Removing the Blades, and Installing the Blades on page 9.

! WARNING

POTENTIAL HAZARD

- A blade that is bent or damaged could break apart and pieces could be thrown at bystanders or at you as you use the mower.

WHAT CAN HAPPEN

- Pieces of blade that may be thrown could seriously injure or kill you or bystanders.

HOW TO AVOID THE HAZARD

- Always replace bent or damaged blade with a new blade.
- Never file or create sharp notches in the edges or surfaces of blade.

Removing the Blades

Blades must be replaced if a solid object is hit, if the blade is out of balance or is bent. To ensure optimum performance and continued safety conformance of the machine, use genuine TORO replacement blades. Replacement blades made by other manufacturers may result in non-conformance with safety standards.

Hold the blade end using a rag or thickly-padded glove. Remove the blade bolt, lock washer, anti-scalp cup and blade from the spindle shaft (Fig. 10).

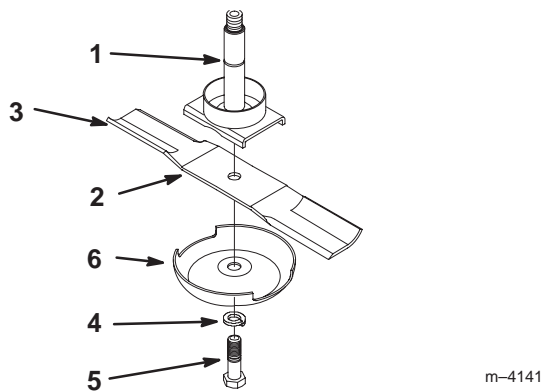

Figure 10

- | | |
|-----------------------|-------------------|
| 1. Spindle | 4. Lock Washer |
| 2. Blade | 5. Blade Bolt |
| 3. Sail Area of Blade | 6. Anti-Scalp Cup |

Sharpening the Blades

1. Use a file to sharpen the cutting edge at both ends of the blade (Fig. 11). Maintain the original angle. The blade retains its balance if the same amount of material is removed from both cutting edges.

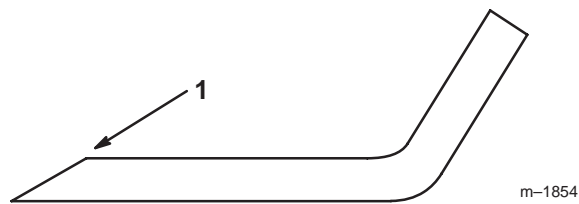

Figure 11

1. Sharpen at original angle

2. Check the balance of the blade by putting it on a blade balancer (Fig. 12). If the blade stays in a horizontal position, the blade is balanced and can be used. If the blade is not balanced, file some metal off the end of the sail area only (Fig. 10). Repeat this procedure until the blade is balanced.

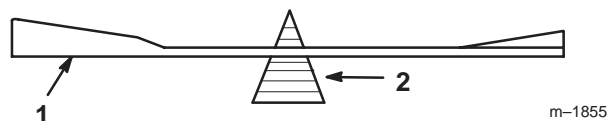

Figure 12

1. Blade
2. Balancer

Installing the Blades

1. Install the blade onto the spindle shaft (Fig. 10).

IMPORTANT: The curved part of the blade must be pointing upward toward the inside of the mower to ensure proper cutting.

2. Install the lock washer and blade bolt (Fig. 10). Torque the blade bolt to 85–110 ft-lb (115–140 N•m).

Correcting Cutting Unit Mismatch

If one cutter blade cuts lower than the other, correct as follows:

1. Stop the engine, remove the key and disconnect the spark plug wire(s) from the spark plug(s).
2. Adjust the tire pressure in all tires to specifications and check that the blades are not bent. Refer to Checking for Bent Blades on page 8.
3. Set the height-of-cut to the 2-1/2" position. Refer to Adjusting the Height-Of-Cut in the Operation section. Make sure the clevis pins are resting on the frame cushions.
4. Rotate the blades so the tips line up with one another. The blade tips must be within 1/8" (3 mm) of each other. If the blade tips are not within 1/8" (3 mm) of each other, add shims (Part No. 3256-24) between the appropriate spindle housing and the bottom of the cutting unit to align the blades.

Setting the Front-to-Rear Pitch

1. Check the tire pressure.
2. Position the blades front-to-rear (Fig. 13). Measure at "C" and "D" locations (Fig. 13) from a level surface to the cutting edge of the blades (Fig. 14).
3. The mower should be 1/8"-5/8" (3-16 mm) lower in front "C" than in the rear "D".

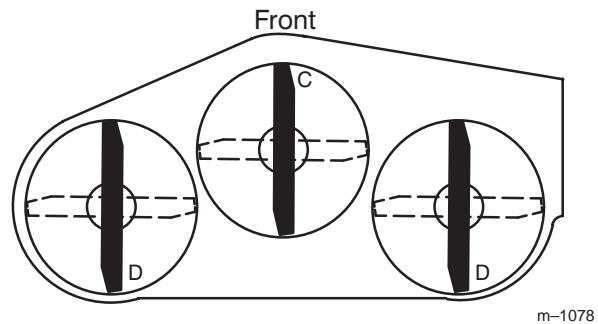
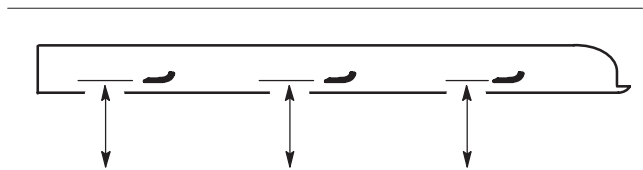

Figure 13



MEASURE FROM
CUTTING EDGE TO A
LEVEL SURFACE

m-2539

Figure 14

4. To change the front-to-rear pitch, move an equal number of thrust washers on both castor wheel forks. Move the thrust washers from the top of the carrier frame mounting tube to the bottom to raise the front of the mower. Move the thrust washers from the bottom of the mounting tube to the top to lower the front of the mower. (Fig. 15).
5. Check the side-to-side leveling of the cutting unit.

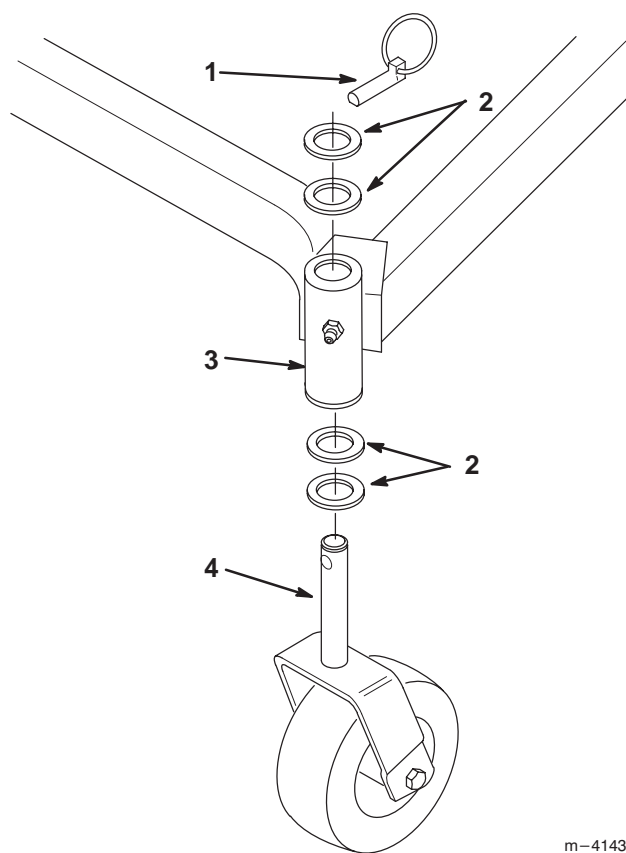

Figure 15

- | | |
|----------------------|--------------------------------|
| 1. Lynch Pin | 3. Carrier Frame Mounting Tube |
| 2. Thrust Washer (4) | 4. Castor Wheel Fork |

Setting the Side-to-Side Leveling

1. Check the tire pressure.
2. Position the blades side-to-side (Fig. 16). Measure at "A" and "B" locations (Fig. 16) from a level surface to the cutting edge of blades (Fig. 17).
3. The difference between measurements "A" and "B" should be no more than 1/4" (6 mm).

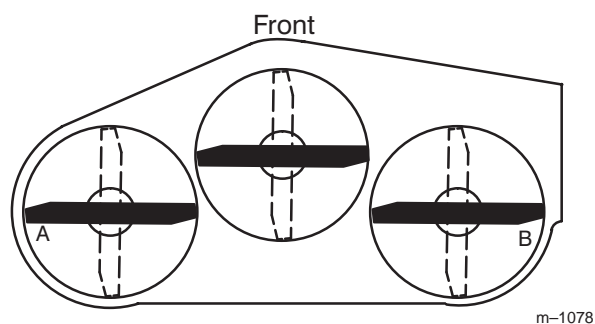
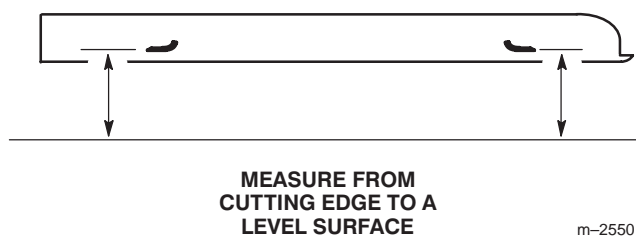

Figure 16



MEASURE FROM
CUTTING EDGE TO A
LEVEL SURFACE

Figure 17

4. To change the side-to-side leveling, move the thrust washers on one castor wheel fork only. Move the thrust washers from the top of the carrier frame mounting tube to the bottom to raise the corresponding side of the mower. Move the thrust washers from the bottom of the mounting tube to the top to lower the corresponding side of the mower. (Fig. 15).
5. Recheck the front-to-rear pitch of the cutting unit.

Greasing and Lubrication

The cutting unit must be lubricated regularly. Refer to the Service Interval Chart on page 7. Grease with No. 2 general purpose lithium base or molybdenum base grease.

1. Stop the engine, remove the key and disconnect the spark plug wire(s) from the spark plug(s).
2. Grease the fittings on the three spindle bearings and the idler arm (Fig. 18).
3. Remove plug on gearbox and check the level of lubrication in the gearbox. If level is low, add SAE EP-90 wt. gear oil until level is up to horizontal (input) shaft of gearbox. (Fig. 18).

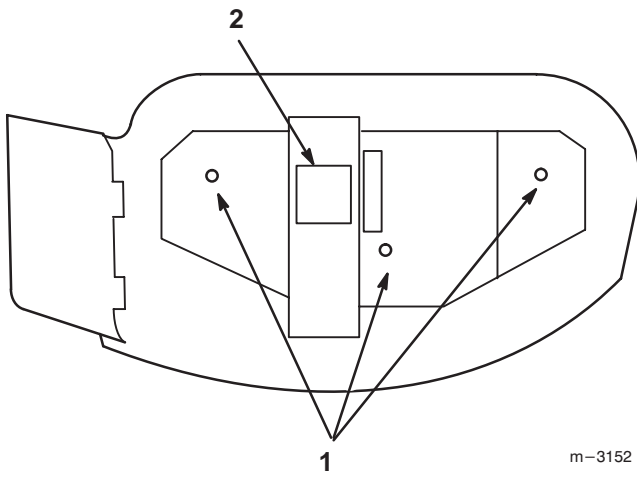

Figure 18

1. Spindle Bearing
2. Plug

4. Grease the fittings on the carrier frame mounting tubes and castor wheels (Fig. 19).

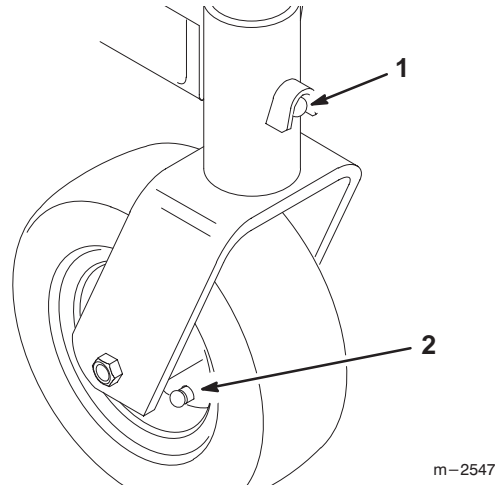

Figure 19

1. Carrier Frame Mounting Tube Grease Fitting
2. Castor Wheel Grease Fitting

Replacing the Deck Belt

Squealing when the belt is rotating, blades slipping when cutting grass, frayed belt edges, burn marks and cracks are signs of a worn deck belt. Replace the deck belt if any of these conditions are evident.

1. Stop the engine, remove the key and disconnect the spark plug wire(s) from the spark plug(s).
2. Open the latches holding the deck covers to the top of the cutting unit and remove the deck covers.
3. Remove the drive belt. Refer to: Replacing the Drive Belt, page 13.
4. Disconnect the Tension bracket and spring to relieve tension on the idler arm and idler pulley, then remove the worn deck belt (Fig. 20).
5. Install the new deck belt around the two outboard spindle pulleys, the fixed idler pulley, and center spindle pulley (Fig. 20).
6. Reconnect the idler arm spring and tension bracket and secure with lock nut (Fig. 20).

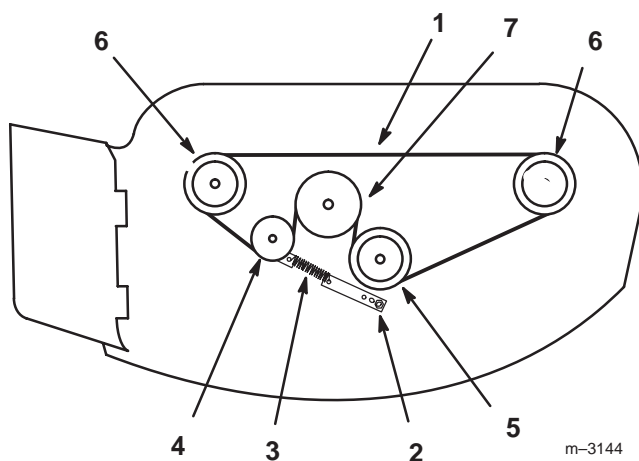

Figure 20

Top View

- | | |
|--------------------|--------------------------------|
| 1. Deck Belt | 5. Center Spindle Pulley |
| 2. Tension bracket | 6. Outboard Spindle Pulley (2) |
| 3. Spring | 7. Fixed Idler Arm Spring |
| 4. Idler Pulley | |

7. Reinstall the drive belt. Refer to Replacing the Drive Belt, page 13.

8. Reinstall the deck covers.

Replacing the Drive Belt

Squealing when the belt is rotating, blades slipping when cutting grass, frayed belt edges, burn marks and cracks are signs of a worn drive belt. Replace the drive belt if any of these conditions are evident.

1. Stop the engine, remove the key and disconnect the spark plug wire(s) from the spark plug(s).
2. Remove wing studs holding belt cover to the top of the cutting unit and remove belt cover.
3. Remove existing drive belt.
4. Install the drive belt around the drive pulley on the traction unit, lift up on the idler and place belt around gearbox pulley (Fig. 21).
5. Install the belt cover onto the cutting unit.

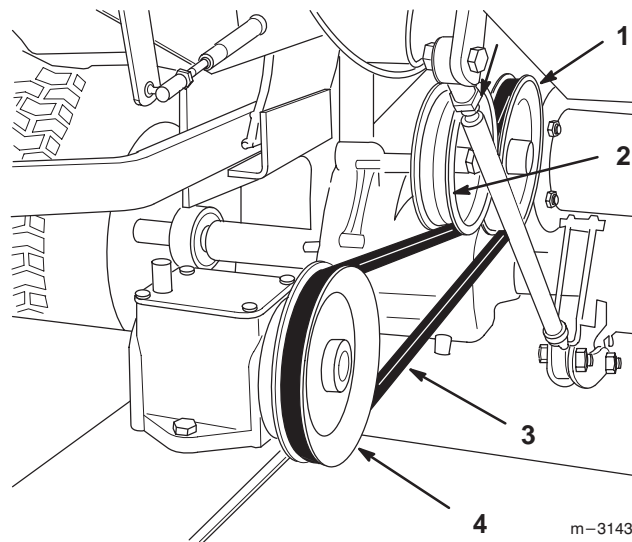

Figure 21

- | | |
|-------------------------------|-------------------|
| 1. Traction Unit Drive Pulley | 3. Drive Belt |
| 2. Idler Pulley | 4. Gearbox Pulley |

Replacing Spindle and Bearings

1. Stop the engine, remove the key and disconnect the spark plug wire(s) from the spark plug(s).
2. Remove wing studs holding belt cover to the top of the cutting unit and remove belt cover.
3. Remove the deck belt: refer to Replacing the Deck Belt, page 13.
4. Remove locknut retaining spindle pulley on spindle shaft. Slide pulley off shaft, which will allow spindle shaft to be removed from spindle housing (Fig. 21).
5. Remove bolts and nuts holding spindle housing and support ring against cutting unit. Slide spindle assemble out bottom of cutting unit (Fig. 21).
6. If spindle shaft is to be replaced, remove blade bolt, lock washer, anti-scalp cup and blade. Otherwise blade can be left attached to spindle.
7. Reposition spacer and bearings in spindle housing. Make sure bearings have open side toward the center and hole in spacer is aligned with groove in shaft (Fig. 21).
8. Install spindle in spindle housing. Make sure bearings and spacer are properly positioned on shaft (Fig. 21).
9. Slide pulley end of spindle assembly through hole in cutting unit. Secure spindle assembly in place with support ring, bolts and nuts previously removed (Fig. 21).
10. Slide pulley onto spindle shaft and secure with locknut (Fig. 21). Torque locknut to 100–120 ft–lb. (135–162 N•m). Rotate shaft to check for free rotation.
11. Grease bearings with No. 2 General purpose lithium base grease until grease is visible at lower seal.

12. Install the belts and belt covers onto the cutting unit.

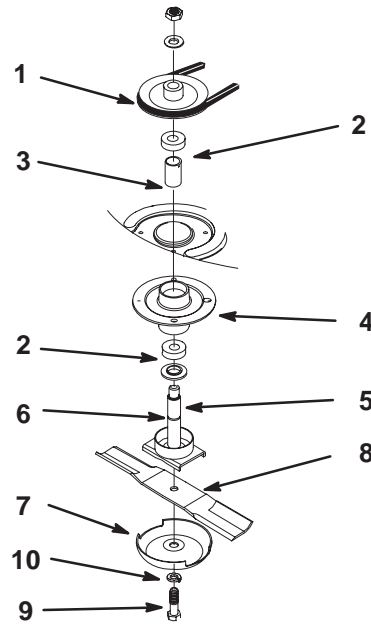

m-4142

Figure 22

- | | |
|--------------------|-------------------|
| 1. Pulley | 6. Spindle Shaft |
| 2. Bearing | 7. Anti-Scalp Cup |
| 3. Spacer | 8. Blade |
| 4. Spindle Housing | 9. Blade Bolt |
| 5. Groove | 10. Washer |

IMPORTANT: If you change to the optional high sail bagging blades, you must remove the right and left side baffles, and rear kickers.

Replacing the Castor Wheel Fork Bushings

The castor wheel forks are mounted in bushings pressed into the top and bottom of the carrier frame mounting tubes. To check the bushings, move the castor forks back and forth and side-to-side. If a castor fork is loose, the bushings are worn and must be replaced.

1. Raise the cutting unit so the castor wheels are off the floor, then block up the front of the mower with jack stands.
2. Remove the lynch pin and thrust washer(s) from the top of the castor wheel fork (Fig. 23).
3. Pull the castor wheel fork out of the mounting tube, leaving the thrust washers on the bottom of the fork. Remember the location of the thrust washers and spacer on each fork to ensure correct installation, and to maintain a level deck.

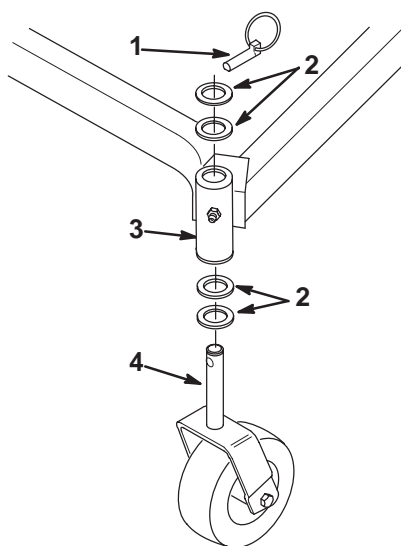

m-4143

Figure 23

- | | |
|--|--------------------------------|
| 1. Lynch Pin | 3. Carrier Frame Mounting Tube |
| 2. Thrust Washers (locate as required) | 4. Castor Wheel Fork |

4. Insert a pin punch into the mounting tube and carefully drive out the bushings (Fig. 24). Clean the inside of the mounting tube.
 5. Grease the inside and outside of the new bushings. Use a hammer and flat plate to carefully drive the bushings into the mounting tube (Fig. 24).
 6. Inspect the castor wheel fork for wear and replace if necessary (Fig. 23).
 7. Slide the castor wheel fork through the bushings in the mounting tube. Replace the thrust washer(s) onto the fork and secure with the lynch pin (Fig. 23).
- IMPORTANT: The inside diameter of the bushings may collapse slightly when installed. If the castor wheel fork does not slide into the new bushings, ream both bushings to an inside diameter of 1.126 in. (28.6mm).**
8. Grease the fitting on the carrier frame mounting tube using No. 2 general purpose lithium base or molybdenum base grease.

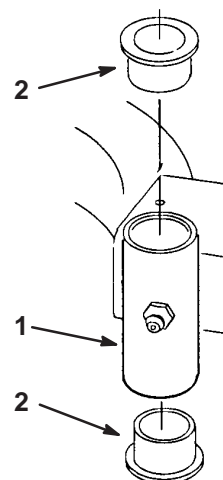

m-1076

Figure 24

- | | |
|--------------------------------|------------|
| 1. Carrier Frame Mounting Tube | 2. Bushing |
|--------------------------------|------------|

Servicing the Castor Wheels and Bearings

The castor wheels rotate on a roller bearing supported by a spanner bushing. If the bearing is kept well lubricated, wear will be minimal. Failure to keep the bearing well lubricated will cause rapid wear. A wobbly castor wheel usually indicates a worn bearing.

1. Remove the locknut and wheel bolt holding the castor wheel to the castor fork (Fig. 25).
2. Remove the washer and bushing, then pull the spanner bushing and roller bearing out of the wheel hub (Fig. 25).
3. Remove the other bushing from the wheel hub and clean any grease and dirt from the wheel hub (Fig. 25).
4. Inspect the roller bearing, bushings, spanner bushing and inside of the wheel hub for wear. Replace any defective or worn parts (Fig. 25).

5. To assemble, place one (1) bushing into the wheel hub. Grease the roller bearing and spanner bushing and slide them into the wheel hub. Place the second bushing into the wheel hub (Fig. 25).
6. Install the castor wheel into the castor fork and secure with the wheel bolt and locknut. Tighten the locknut until the spanner bushing bottoms against the inside of the castor forks (Fig. 25).
7. Grease the fitting on the castor wheel.

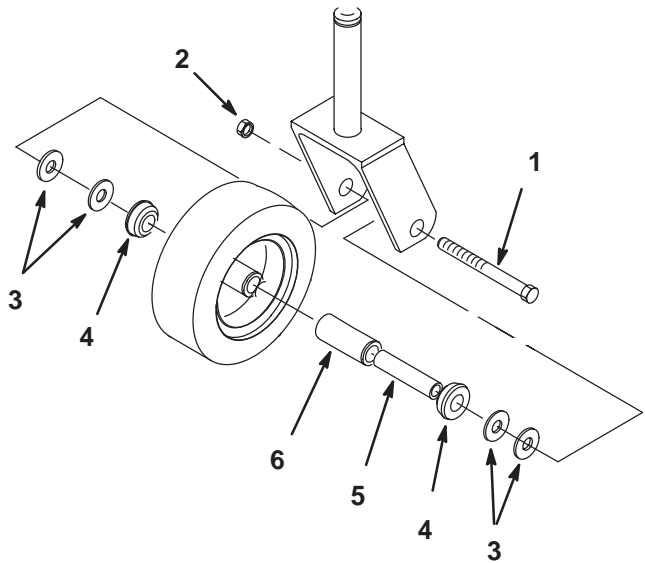

m-3986

Figure 25

- | | |
|---------------|--------------------|
| 1. Locknut | 4. Bushing |
| 2. Wheel bolt | 5. Spanner bushing |
| 3. Washer (4) | 6. Roller bearing |

Replacing the Grass Deflector

1. Remove the locknuts, bolts and springs holding the deflector mounts to the pivot brackets (Fig. 26).
2. If the pivot brackets need to be replaced, remove the carriage bolts and cone locknuts holding the old brackets to the top of the discharge opening, then install the replacement pivot brackets. Make sure the carriage bolt heads are on the inside of the cutting unit (Fig. 26).
3. Install the deflector mounts onto the pivot brackets with the bolts, springs and locknuts. Make sure the straight ends of the springs are positioned between the deflector mounts and the grass deflector (Fig. 26).
4. Tighten the locknuts until they contact the pivot brackets (Fig. 26).

IMPORTANT: The grass deflector must be spring-loaded in the down position. Lift the deflector up to test that it snaps to the full down position.

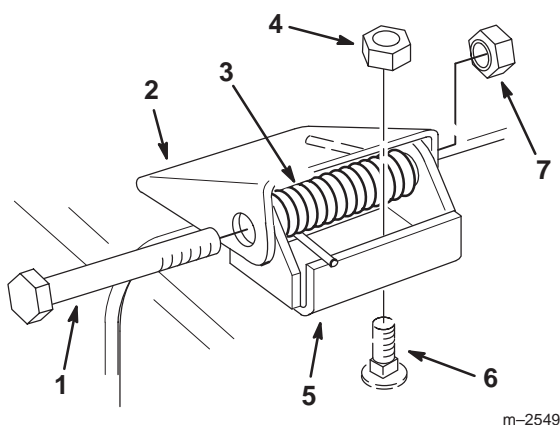

Figure 26

- | | |
|--------------------|------------------|
| 1. Bolt | 5. Pivot Bracket |
| 2. Deflector Mount | 6. Carriage Bolt |
| 3. Spring | 7. Locknut |
| 4. Cone Locknut | |

Storage

1. Clean any dirt and chaff from the top of the mower.
2. Scrape any heavy buildup of grass and dirt from the underside of the mower, then wash the mower with a garden hose.
3. Check the condition of the blades. Refer to Cutting Blades on page 7.
4. Check the condition of the drive and deck belts.
5. Check and tighten all bolts, nuts and screws. Repair or replace any part that is damaged or defective.
6. Paint all scratched or bare metal surfaces. Paint is available from your Authorized Service Dealer.
7. Store the machine in a clean, dry garage or storage area. Cover the machine to protect it and keep it clean.

Troubleshooting

PROBLEM	POSSIBLE CAUSES	CORRECTIVE ACTION
Abnormal vibration.	<ol style="list-style-type: none"> 1. Cutting blade(s) is/are bent or unbalanced. 2. Blade mounting bolt is loose. 3. Engine mounting bolts are loose. 4. Loose engine pulley, idler pulley, or blade pulley. 5. Engine pulley is damaged. 6. Blade spindle bent. 	<ol style="list-style-type: none"> 1. Install new cutting blade(s). 2. Tighten blade mounting bolt. 3. Tighten engine mounting bolts. 4. Tighten the appropriate pulley. 5. Contact Authorized Service Dealer. 6. Contact Authorized Service Dealer.
Uneven cutting height.	<ol style="list-style-type: none"> 1. Blade(s) not sharp. 2. Cutting blade(s) is/are bent. 3. Mower is not level. 4. Underside of mower is dirty. 5. Tire pressure is incorrect. 6. Blade spindle bent. 	<ol style="list-style-type: none"> 1. Sharpen blade(s). 2. Install new cutting blade(s). 3. Level mower from side-to-side and front-to-rear. 4. Clean the underside of the mower. 5. Adjust tire pressure. 6. Contact Authorized Service Dealer.
Blades do not rotate.	<ol style="list-style-type: none"> 1. Drive belt is worn, loose or broken. 2. Drive belt is off pulley. 3. Deck belt is worn, loose or broken. 4. Deck belt is off pulley. 	<ol style="list-style-type: none"> 1. Install new drive belt. 2. Install drive belt and check adjusting shafts and belt guides for correct position. 3. Install new deck belt. 4. Install deck pulley and check the idler pulley, idler arm and spring for correct position and function.