

# **R-TEK/DURAFORCE (E) ENGINE SERVICE MANUAL**

Table of Contents – Page 1 of 1

[PREFACE](#)

[SAFETY](#)

[SPECIFICATIONS](#)

[SPECIAL TOOLS](#)

[TROUBLESHOOTING](#)

[MAINTENANCE](#)

[CARBURETOR](#)

[FUEL SYSTEM](#)

[IGNITION SYSTEM](#)

[REWIND STARTER](#)

[ENGINE](#)

[PIVOTING ZONE START BRAKE](#)

[ELECTRIC START SYSTEM \(120 VOLT\)](#)

[ELECTRIC START SYSTEM \(12 VOLT\)](#)

**TORO**®

**E Engine**

# SERVICE MANUAL

**LAWN-BOY**

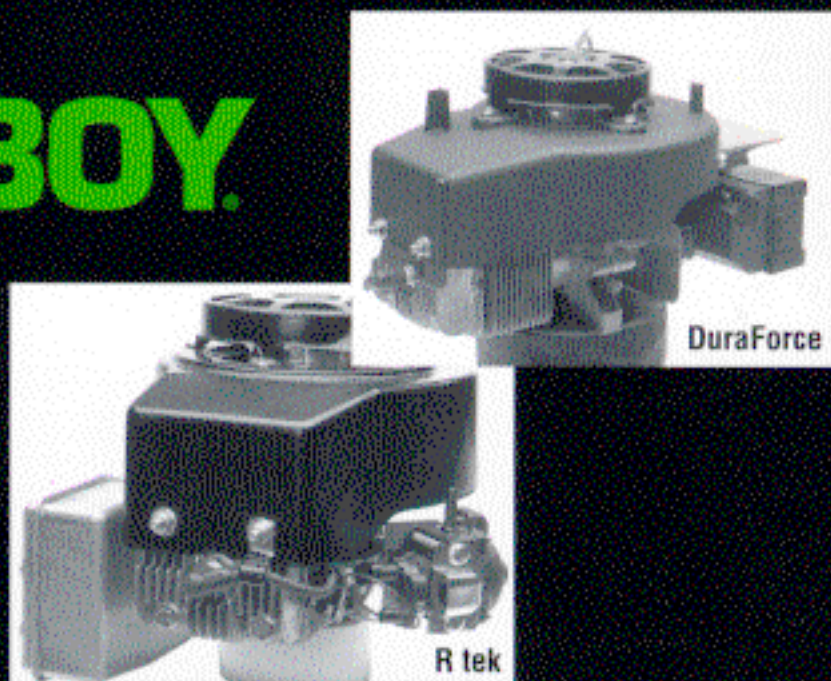

DuraForce

R tek

# PREFACE

---

## ABOUT THIS MANUAL

This manual was written expressly for the E series engines. There are two engines in this series. One is piston ported (R tek) and the other is a reed valve (DuraForce). As these engines are of the same family, they will both be covered here. Where there are differences between the two versions, a heading will state which engine is being discussed. We have made every effort to make this information complete and correct.

We hope that you find this manual a valuable addition to your service shop. If you have questions or comments regarding this manual, please contact us at the following address:

The Toro Company  
Consumer Service Department  
8111 Lyndale Ave. So.  
Minneapolis, MN 55420-1196

The Toro Company reserves the right to change product specifications or this manual without notice.

# TABLE OF CONTENTS

## TABLE OF CONTENTS

- SAFETY** ..... 1
  
- SPECIFICATIONS** ..... 2
  - Engine Specifications (All dimensions are for a new engine) .....2
  - Engine Fastener Torque Requirements ..... 3
  - Standard Torques .....4
  - Carburetor Specifications .....4
  
- SPECIAL TOOL REQUIREMENTS** ..... 5
  
- TROUBLESHOOTING** .....6
  - Engine Will Not Start When “Cold” ..... 6
  - Engine Will Start When “Cold”, But Not When “Hot” .....6
  - Engine Will Not Produce Spark .....7
  - Engine Flooded With Fuel .....7
  - Engine Has Low Compression .....7
  - Engine Lacks Power .....8
  - Engine Surges .....8
  - Engine Backfires ..... 8
  - Engine Overheats .....9
  - Engine Vibrates Excessively .....9
  - Engine Crankshaft Will Not Turn .....9
  - Engine Produces Mechanical Knocking Sound .....9
  - Engine Pre-Ignites .....10
  - Engine Smokes Excessively (Smoke is light colored, engine runs well) .....10
  - Engine Smokes Excessively (Smoke is dark, engine runs poorly) .....10
  - Engine Stalls .....11
  - Spark Plug Fouled .....11
  
- MAINTENANCE** .....13
  - Recommended Maintenance Schedule .....13
  - Air Filter (Mower Only) .....14
  - Spark Plug .....14
  - Cleaning the Exhaust System (Lawn Mower) .....15
  - Cleaning the Exhaust System (Snowthrower) .....16
  - Reassembling Exhaust System (Mower Only) .....16

# TABLE OF CONTENTS

---

<b>CARBURETOR</b> .....	<b>17</b>
Identification .....	17
Theory of Operation .....	17
Troubleshooting .....	18
Preliminary Check .....	19
Removal of DuraForce Carburetor .....	20
Removal of R tek Carburetor .....	20
Disassembly .....	21
Cleaning and Inspection .....	23
Assembly .....	23
Installation .....	25
Governor Theory .....	26
Reed Valve Engine (DuraForce Engines Only) .....	26
Piston Ported Engine (R tek Engines Only) .....	26
Presetting the Governor (DuraForce Engines Only) .....	26
Servicing the Air Filter (DuraForce Engines Only) .....	27
<b>FUEL SYSTEM</b> .....	<b>29</b>
Operation .....	29
Fuel Cap Service .....	29
Cleaning .....	29
<b>IGNITION SYSTEM</b> .....	<b>31</b>
Troubleshooting .....	31
Testing .....	31
Spark Plug Operation .....	31
Spark Plug Service .....	32
CD Pack Operation .....	32
CD Pack Air Gap Adjustment .....	33
CD Pack Removal/Installation .....	33
Flywheel Operation .....	34
Flywheel Removal .....	34
Flywheel Installation .....	35

# TABLE OF CONTENTS

---

<b>REWIND STARTER</b> .....	<b>.37</b>
Operation .....	.37
Removal and Disassembly .....	.37
Reassembly .....	.37
<b>ENGINE</b> .....	<b>.39</b>
General Information .....	.39
Theory of Operation .....	.39
Reed Valve Engine .....	.39
Piston Ported Engine .....	.40
Both Piston Ported and Reed Valve Engines .....	.40
Service Tips .....	.41
Disassembly .....	.41
Inspection and Repair .....	.42
Reed Valve Service (DuraForce Engines Only) .....	.43
Reassembly .....	.44
Reinstalling External Components .....	.45
Crankshaft Seal Replacement .....	.46
<b>PIVOTING ZONE START BRAKE</b> .....	<b>.47</b>
Introduction .....	.47
Operation .....	.47
Disassembly .....	.48
Assembly .....	.49
<b>ELECTRIC START SYSTEM (120 VOLT)</b> .....	<b>.51</b>
Troubleshooting .....	.51
Introduction .....	.51
Starter Removal .....	.51
Starter Disassembly .....	.52
Starter Assembly .....	.52
Starter Installation .....	.52

# TABLE OF CONTENTS

---

<b>ELECTRIC START SYSTEM (12 VOLT)</b> .....	<b>.53</b>
Troubleshooting .....	.53
Introduction .....	.53
Starter Removal .....	.53
Starter Testing .....	.54
Starter Disassembly .....	.54
Starter Assembly .....	.55
Starter Installation .....	.55
Alternator Introduction .....	.56
Alternator Output Testing .....	.57
Alternator Air Gap Adjustment .....	.57
Alternator Resistance Check .....	.57
Cup Assembly Test .....	.57

## SAFETY INFORMATION

### General



This safety symbol means WARNING or PERSONAL SAFETY INSTRUCTION - read the instruction because it has to do with your safety. Failure to comply with the instruction may result in personal injury or even death.

This manual is intended as a service and repair manual only. The safety instructions provided herein are for troubleshooting, service, and repair of the engine only. The individual Operator's manual will contain safety information on the complete product powered by the E series engine. Operator's manuals with complete instructions are available through:

Lawn-Boy Corporation / The Toro Company  
Parts Department  
8111 Lyndale Avenue South  
Bloomington, MN 55420 U.S.A.

## Safety Tips

### **Avoid unexpected starting of engine...**

Always turn off the powered product and disconnect the spark plug wire before attempting cleaning, adjustment, or repair.

### **Avoid lacerations and amputations...**

Stay clear of all moving parts whenever the engine is running. Treat all normally moving parts as if they were moving whenever the engine is running or has the potential to start.

### **Avoid burns...**

.Do not touch the engine while it is running or shortly after it has been running.

### **Avoid Falls...**

Do not operate the powered product on slippery surfaces or if footing is questionable.

### **Avoid fires...**

Wipe up any spilled fuel or oil immediately.

### **Avoid asphyxiation...**

Never operate an engine in a confined area without proper ventilation.

### **Avoid fires and explosions...**

Use a container designed for gasoline. Avoid spilling fuel and never smoke while working with any type of fuel.

### **Avoid accidental misuse of fuel...**

Always store fuel in a properly labeled container designed for gasoline.

### **Avoid injury due to inferior parts...**

Use only Toro/Lawn-Boy original parts to ensure that important safety criteria are met.

### **Avoid injury to bystanders...**

Always clear the area of bystanders before starting or testing powered equipment.

### **Avoid injury due to projectiles...**

Always clear the area of sticks, rocks, or any other debris that could be picked up and thrown by the powered equipment. Keep all safety shields in place.

### **Avoid modifications...**

Never alter or modify any part unless it is a factory approved procedure.

### **Avoid unsafe operation...**

Always test the safety systems after making adjustments or repairs on the machine.



# SPECIFICATIONS

## Specifications

### Engine Specifications (All dimensions are for a new engine)

Item	DuraForce	R tek
Type	Reed valve 2-cycle	Piston ported 2-cycle
Bore	2.5000" $\pm$ .0005 (63.5mm $\pm$ .0127)	
Stroke	1.75" (44.45mm)	
Wrist pin diameter	.5000" + .0000 - .0002 (12.70mm + .000 - .005)	
Crankpin diameter	.7427" + .0003 - .0002 (18.85mm + .008 - .005)	
End play (crankshaft)	0 - .017" (0 - .431mm) Walk mower	0 - .017" (0 - .431mm) 1998 Snow 0 - .0215" (0 - .533mm) 1999 and later Snow
Side play (crankshaft) near lower main	.0006" + .0003 - .0006 (.015mm + .008 - .015)	
Piston cyl. Clearance (tightest loc.)	.0035" to .0059" (.089 to .150mm)	
Wrist pin hole diameter	.500"/.5005" (12.705mm / 12.712mm)	
Bottom ring thickness, new	.0600 $\pm$ .0005 (1.52mm $\pm$ .013)	
End gap, new (both rings)	.016/.008 in. (.40/.20mm)	
Displacement	8.6 cu in. (141cc)	
Horsepower	6.5HP	4 or 5HP
Compression ratio	5.8:1	
Compression	Approximately 115 psi. Service limit 80 psi.	
Carburetor	Dual-circuit Lawn-Boy with fixed jets, float type with primer and choke	
Fuel required	Unleaded regular (87 octane R+M/2):2-cycle oil	
Mix ratio	32:1	50:1
Recommended Oil	Lawn-Boy Generation II 2-cycle oil or NMMA TCW3	Toro 2-cycle oil or NMMA TCW3
Fuel tank capacity	Varies with product	
Ignition type	Solid-state CD Pack, magneto type	
CD Pack air gap	.010" (.25mm)	
Spark plug / air gap	NGK projected nose / NGK BPMR4A .030" (.76mm)	
Start system	Rope rewind or 12 VDC	Rope rewind or 120 VAC
Governor	Air vane	
Governed Engine Speed	2900 $\pm$ 300 rpm	4HP runs at 3700 $\pm$ 300 CCR 2400 - 3700 5HP runs at 3800 $\pm$ 300 rpm CCR 2450 & 2500 - 3800 rpm CCR 3600 - 3900 rpm CCR 3650 - 4000 rpm Snow Commander - 4000 rpm All snow engines are $\pm$ 300 rpm
Idle Speed	2200 - 2800 rpm	N/A
Air Cleaner	Oiled foam type with Centrifugal pre-cleaner	N/A

# SPECIFICATIONS

Item	DuraForce	R tek
Choke	Manual, butterfly type	
Fuel filter	In-tank and in-carburetor	
Piston rings	Cast iron, semi-keystone top ring. Second ring is rectangular. Anti-rotation pin in piston.	
Piston	Permanent mold, high silicon aluminum	

## ***Engine Fastener Torque Requirements***

Item	DuraForce	R tek
Bolt, Head	140 - 200 in. lbs. (16 - 22 Nm)	140 - 200 in. lbs. (16 - 22 Nm)
Jet, Main	4 - 6 in. lbs. (.44 - .66 Nm)	4 - 6 in. lbs. (.44 - .66 Nm)
Jet, Pilot*	10 - 12 in. lbs. (1.1 - 1.3 Nm)	6 - 8 in. lbs. (.66 - .88 Nm)*
Nozzle, Carburetor*	16 - 28 in. lbs. (1.7 - 4.0 Nm)	20 - 30 in. lbs. (2.2 - 3.4 Nm)
Nut, Blade	45 - 50 ft. in. (60 - 67 Nm)	NA
Nut, Flywheel	375 - 425 in. lbs. (42 - 47 Nm)	375 - 425 in. lbs. (42 - 47 Nm)
Seat, Float Valve*	16 - 28 in. lbs. (1.7 - 4.0 Nm)	22-32 in. lbs. (2.4 - 3.5 Nm)
Screw, Brake Plate Assembly	60 - 70 in. lbs. (6.7 - 7.8 Nm)	NA
Screw, Carburetor Mounting	20 - 30 in. lbs. (2.2 - 3.4 Nm)	20 - 30 in. lbs. (2.2 - 3.4 Nm)
Screw, CD Ignition Pack	90 - 110 in. lbs. (10 - 12 Nm)	90 - 110 in. lbs. (10 - 12 Nm)
Screw, Cylinder to Crankcase	55 - 90 in. lbs. (6.2 - 10.0 Nm)	55 - 90 in. lbs. (6.2 - 10.0 Nm)
Screws, Engine Mounting	170 - 220 in. lbs. (19 - 25 Nm)	170 - 220 in. lbs. (19 - 25 Nm)
Screw, Float Bowl	10 - 13 in. lbs. (1.1 - 1.5 Nm)	10 - 13 in. lbs. (1.1 - 1.5 Nm)
Screw, Muffler (611228)	55 - 90 in. lbs. (6.2 - 10.0 Nm)	55 - 90 in. lbs. (6.2 - 10.0 Nm)
Screw, Muffler Cover	55 - 90 in. lbs. (6.2 - 10.0 Nm)	NA
Screw, Muffler Plate	140 - 200 in. lbs. (16 - 22 Nm)	NA
Screw, Reed	10 - 13 in. lbs. (1.1 - 1.5 Nm)	NA
Screw, Rod Cap to Rod	65 - 75 in. lbs. (7.3 - 8.4 Nm)	65 - 75 in. lbs. (7.3 - 8.4 Nm)
Screw, Shroud	58 - 70 in. lbs. (6.5 - 7.8 Nm)	58 - 70 in. lbs. (6.5 - 7.8 Nm)
Screw, Shroud Base	58 - 70 in. lbs. (6.5 - 7.8 Nm)	58 - 70 in. lbs. (6.5 - 7.8 Nm)
Spark Plug	150 - 200 in. lbs. (17 - 23 Nm)	150 - 200 in. lbs. (17 - 23 Nm)
Rewind Starter to blower housing	NA	20-30 in. lbs. (2.2 - 3.4 Nm)
Screw, Manifold	NA	55 - 70 in. lbs. (6.2 - 7.8 Nm)
Screw, Muffler	NA	100 - 130 in. lbs.

\* Overtorquing will crack the carb body and cause the engine to run rich

page rev 8/06

# SPECIFICATIONS

Item	DuraForce	R tek
Nut, Shroud	100 - 130 in. lbs. (10 - 14 Nm)	140 - 170 in. lbs. (16 - 19 Nm)
Screw, Starter Bracket to Recoil	NA	30 - 35 in. lbs. (3.4 - 3.8 Nm)
Screw, Gov Pivot Block to Cyl.	NA	30 - 35 in. lbs. (3.4 - 3.8 Nm)
Screw, Elect Start to Crankcase	140 - 200 in. lbs. (16 - 22 Nm)	75 - 100 in. lbs. (8.2 - 11 Nm)

## Standard Torques

Size	US (Metric)
#10 - 24	20 - 30 in. lbs. (5.1 - 6.21 Nm)
1/4 - 20	55 - 90 in. lbs. (6.2 - 10.0 Nm)
5/16 - 18	140 - 200 in. lbs. (16 - 22 Nm)

## Carburetor Specifications

Item	DuraForce	R tek
Type	Lawn-Boy, float type, dual-circuit, with primer and choke	
Body Material	Minlon	
Seat material	Brass with Viton tipped needle. Both are replaceable.	
Inlet Needle "Pop-Off" Pressure	5 psi (.7 kg/cm <sup>2</sup> ) (Wet)	
Main Jet	77.5	73.8
Main Nozzle	Brass	
Pilot Jet	37.5	42.5
High Altitude	NA	
Float Adjustment	Float height .500 ± .030" bowl flange (no gasket) to top of float	

## SPECIAL TOOL REQUIREMENTS

### *Listing*

Description	Order From	Part Number	Comments/Use
Air Gap Gauge	Toro	604659	Sets .010" (.25 mm) gap between flywheel and coil
Piston Ring Compressor	OTC	TOR 4089	Compresses piston rings to allow installation into the cylinder
Wrist Pin Knockout Tool	Toro	602884	Used to drive wrist pin out of piston

OTC Tool & Equipment Division  
SPX Corporation  
Industrial Park  
2013 4th Street NW  
Owatonna, MN 55060  
Telephone: 800-533-0492  
Fax: 507-455-7011

# TROUBLESHOOTING

---

## TROUBLESHOOTING

### *Engine Will Not Start When “Cold”*

Possible Causes	Remedies
Fuel tank is empty	Fill with clean, fresh, properly-mixed, unleaded fuel
Bad fuel	Drain tank and float bowl. Fill the tank with clean, fresh, unleaded, properly-mixed fuel.
Fuel filter plugged	Replace fuel tank
Air cleaner plugged	Wash and re-oil air cleaner element (DuraForce only)
Fouled spark plug	Remove and replace the spark plug
No spark at spark plug	See “Engine Will Not Produce Spark” table
Insufficient momentum	Check for loose blade, mower only
Incorrect ignition timing	Check for sheared flywheel key
Low compression	See “Engine Has Low Compression” table
Engine flooded with fuel	See “Engine Flooded With Fuel” table
Reed valves not closed	Replace reed valves (DuraForce only)
Reed valves stuck closed	Free up and run engine to clean (DuraForce only)
Primer or choke not operating	Fix or replace

### *Engine Will Start When “Cold”, But Not When “Hot”*

Possible Causes	Remedies
Engine is flooded	See “Engine Flooded With Fuel” table
Excessive alcohol in fuel	Use no more than 10% ethanol blend. Avoid methanol
Engine is overheated	See “Engine Overheats” table
Clogged bowl vent	Clean bowl vent
Fuel percolation (vapor lock)	Use current season gas for fuel mixture

# TROUBLESHOOTING

## ***Engine Will Not Produce Spark***

<b>Possible Causes</b>	<b>Remedies</b>
Spark plug wire disconnected	Reconnect spark plug wire
Spark plug fouled or damaged	Replace spark plug
Spark plug wire damaged	Replace CD pack
Coil kill wire grounded	Locate and eliminate the unwanted ground
Ignition coil failed	Replace CD pack
Flywheel magnets weak	Replace flywheel

## ***Engine Flooded With Fuel***

<b>Possible Causes</b>	<b>Remedies</b>
Overuse of choke position	Take throttle off choke
Throttle cable misadjusted	Adjust throttle cable, if present
Air cleaner plugged	Wash and re-oil air cleaner element (DuraForce only)
Fouled spark plug	Replace spark plug
Carburetor inlet needle stuck open or leaking	Clean carburetor, replace failed parts, and pressure test
Carburetor Air Vent	Clean Air Vent

## ***Engine Has Low Compression***

<b>Possible Causes</b>	<b>Remedies</b>
Worn piston rings	Replace piston rings or short block
Piston ring(s) stuck in groove	Replace piston and rings
Cylinder worn	Remove and replace short block

# TROUBLESHOOTING

---

## ***Engine Lacks Power***

<b>Possible Causes</b>	<b>Remedies</b>
Dull blade	Sharpen or replace blade, mower only
Housing choked with grass and debris	Clean housing thoroughly, mower only
Plugged exhaust system	Clean exhaust ports
Muffler plugged	Clean or replace muffler
Flywheel key sheared	Replace flywheel key
Carburetor dirty	Clean carburetor
Intake air leak	Repair or replace failed components(s)
Low compression	See "Engine Has Low Compression" table

## ***Engine Surges***

<b>Possible Causes</b>	<b>Remedies</b>
Fouled idle circuit	Clean idle circuit
Air leak	Check sealing surfaces, oil seals, gaskets, and port plugs
Restricted fuel flow	Check filters and fuel line
Engine RPM low	Adjust to proper specification. Note: A slight surge at no load is normal.
Governor link misadjusted (R tek)	Adjust
Air vane sticking	Clean or replace

## ***Engine Backfires***

<b>Possible Causes</b>	<b>Remedies</b>
Flywheel key sheared	Replace key
Muffler filled with carbon	Clean muffler
Exhaust ports plugged	Clean ports
Air leak to crankcase	Replace seals or re-seal crankcase to cylinder
Spark plug partly fouled	Clean or replace

## ***Engine Overheats***

<b>Possible Causes</b>	<b>Remedies</b>
Cylinder head cooling fins clogged	Clean fins thoroughly
Restricted carburetor jets	Clean carburetor and jet
Improper gas to oil mix ratio	Ensure mixture is correct
Cooling air intake plugged	Remove foreign material and clean

## ***Engine Vibrates Excessively***

<b>Possible Causes</b>	<b>Remedies</b>
Blade out of balance	Balance blade or replace if damaged
Bent blade	Replace blade
Loose engine mounting screws	Tighten engine mounting screws (engine to plate, plate to mower housing)
Bent crankshaft	Replace crankshaft
Flywheel out of balance (damaged)	Replace flywheel

## ***Engine Crankshaft Will Not Turn***

<b>Possible Causes</b>	<b>Remedies</b>
Engine brake incorrectly engaged	Disengage brake and inspect and repair as necessary, mower only
Blade jammed in housing	Inspect and repair or replace, mower only
Piston seized in its cylinder	Inspect and repair or replace
Starter jammed	Repair starter

## ***Engine Produces Mechanical Knocking Sound***

<b>Possible Causes</b>	<b>Remedies</b>
Loose blade	Inspect and tighten blade nut to correct torque, mower only
Loose flywheel	Inspect and tighten flywheel nut to correct torque
Pre-ignition is occurring	See "Engine Pre-Ignites" table
Loose rod cap	Replace rod and bearings
Loose engine mounting bolts	Tighten bolts



# TROUBLESHOOTING

---

## ***Engine Pre-Ignites***

<b>Possible Causes</b>	<b>Remedies</b>
Wrong spark plug - too hot	Install the correct type of spark plug
Low quality fuel (old or stale)	Replace with fresh, unleaded regular fuel
Carbon buildup in engine	Decarbon engine and muffler
Excessive alcohol in fuel	Replace with fresh unleaded fuel having no more than 10% ethanol
Sheared flywheel key	Inspect and repair

## ***Engine Smokes Excessively (Smoke is light colored, engine runs well)***

<b>Possible Causes</b>	<b>Remedies</b>
Slight oil accumulation in crankcase	None; normal on start-up
Air cleaner element clogged	Clean and re-oil or replace air cleaner element, mower only
Fuel/oil mixture too rich	Drain fuel tank and fill with fuel of correct mixture
Choke is in "On" position	Move to high speed or "Off" position

## ***Engine Smokes Excessively (Smoke is dark, engine runs poorly)***

<b>Possible Causes</b>	<b>Remedies</b>
Carburetor running too rich	Clean and check carburetor
Choke is in "On" position	Move to high speed or "Off" position

# TROUBLESHOOTING

## ***Engine Stalls***

<b>Possible Causes</b>	<b>Remedies</b>
Engine out of fuel	Refill with fresh fuel of the correct mixture
Engine overloaded	Unload engine and restart
Fuel filter plugged	Clean fuel filter/tank
Spark plug fouled	See "Spark Plug Fouled" table
Fuel cap vent plugged	Replace fuel cap
Ignition inadvertently grounded	Inspect and repair to remove unwanted ground
Carburetor vent plugged	Clear vent of obstruction
Engine overheated	Clear debris from fins or cause of overheating
Improper lubrication	Tear down and inspect for damage

## ***Spark Plug Fouled***

<b>Possible Causes</b>	<b>Remedies</b>
Incorrect spark plug	Use correct spark plug
Carburetor running too rich	Clean/rebuild carburetor
Clogged air cleaner element	Clean and re-oil element or replace, mower only
Overuse of "choke" position	Move control off "choke" position and check throttle cable adjustment
Weak ignition system	Replace CD ignition pack
Worn rings and/or cylinder	Rebuild engine or short block
Use of poor fuel	Drain fuel tank and replace with fresh, unleaded regular fuel having the correct oil mixture
Fuel/oil mixture too rich	Drain fuel tank and fill with fuel of correct mixture
Wrong Oil	Use Toro 2-cycle oil, Lawn-Boy DuraForce oil, or NMMA TCW3 approved oil

**THIS PAGE INTENTIONALLY LEFT BLANK**

## *Recommended Maintenance Schedule*

Frequency	Item	Comments
5 Hours	Fasteners	Check blade and engine mounting fasteners frequently. Keep all nuts, bolts, and screws tight to ensure safe operation.
25 Hours	Housing	(Mower only.) Remove the buildup of grass clippings and dirt.  (Self-propelled mower only.) Clean grass clippings and debris under drive belt mechanism cover and drive belt.
	Spark Plug	Clean, inspect, and regap; replace if necessary.
50 Hours	Air Filter	(Mower only.) Remove and clean each mowing season or every 50 hours; more frequently if operating conditions are dusty.
	Blade  Blade Brake	(Mower only.) Sharpen or replace; maintain more frequently if edge is dulled quickly in rough or sandy conditions.  Check stopping time every 50 hours or at start of each mowing season. Blade must stop within 3 seconds of releasing bail. If not, repair or replace.
	Lubrication	(Self-propelled mowers only.) Grease rear height adjuster brackets.
	Exhaust Ports	Clean every 50 hours or at least once each season.
	Fuel System	Check for leakage and/or deterioration of fuel hose. Replace if necessary.
100 Hours	Cooling System	Clean grass clippings, debris, or dirt that clog engine air cooling fins; clean more frequently under dirty or high chaff conditions.

# MAINTENANCE

## Air Filter (Mower Only)

Once every season, or every 50 hours, clean the air filter housing and element. Do so more frequently under dusty conditions.

Note: Do not operate the engine without the air filter in place. Doing so may damage the engine or cause excessive engine wear.

1. To remove air filter (A), snap cover latch open, swing to side, and unhook. Remove the cover (B) and air filter. (See Figure 1.)

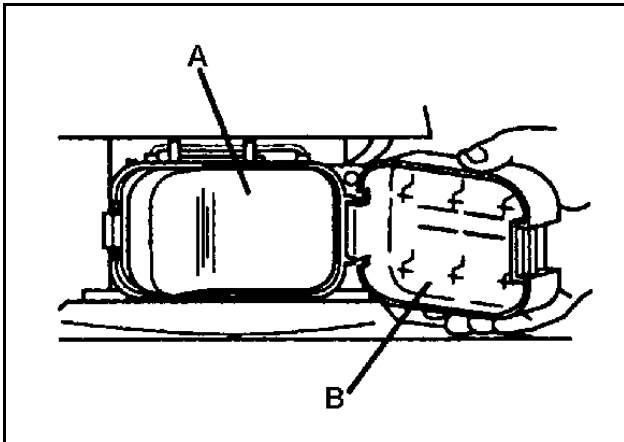

Figure 1

3297-005

2. Wash air filter in laundry detergent and water. Squeeze filter to remove excess liquid and blot dry with a paper towel or rag (see Figure 2). Do not wring out the element or damage may occur.

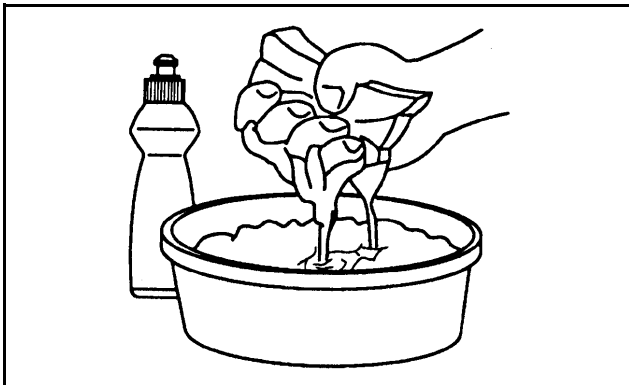

Figure 2

3329-006

3. Apply one tablespoon SAE 30 or similar oil to the air filter (see Figure 3). Lightly squeeze filter until oil is distributed evenly throughout the filter. Blot lightly with paper towel to remove excess oil. Replace filter with cleanest side facing carburetor.

Note: Be sure filter is properly seated in air box and is not puckered (allowing direct passage of air and dirt to carburetor).

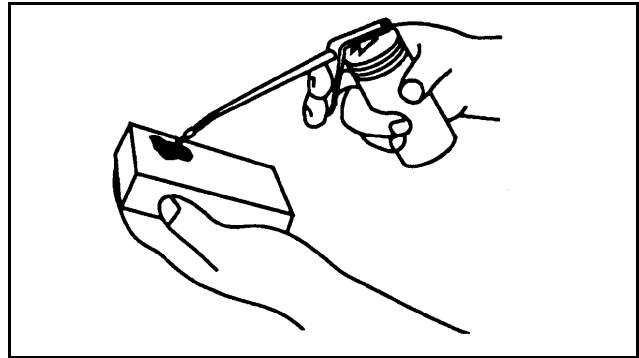

Figure 3

3297-007

## Spark Plug

A spark plug that is dirty, pitted, carbon covered, or has worn electrodes may cause hard starting and poor operation.

Replace spark plug once a season or every 25 hours, whichever occurs first. Use NGK BPMR 4A or equivalent.

1. Set spark plug gap to .030 (.76 mm). (See Figure 4.)

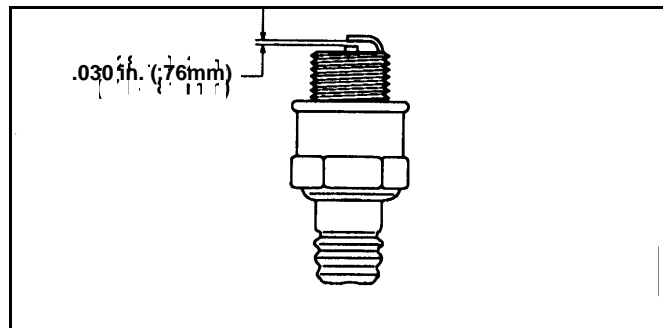

Figure 4

3297-008

2. Install spark plug finger tight, then torque per specifications. (See Figure 5.)

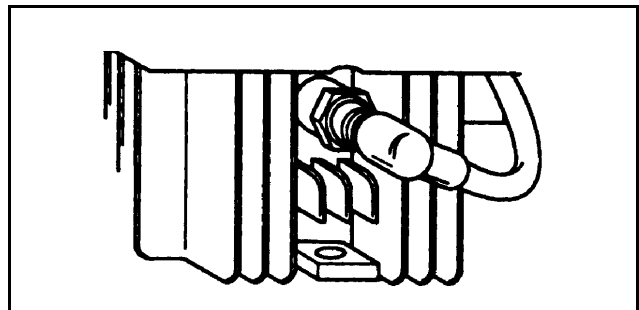

Figure 5

3297-009

## Cleaning the Exhaust System (Lawn Mower)

Warning: Disconnect the spark plug wire to prevent accidentally starting the engine.

1. (Mower) Using a 1/2" drive with a 15/16" socket, remove the blade nut that secures both the mulch fan and blade to the engine. Use heavy-duty gloves to hold the blade while removing the nut. (See Figure 6.) Note: Removing the blade is merely for convenience while working.

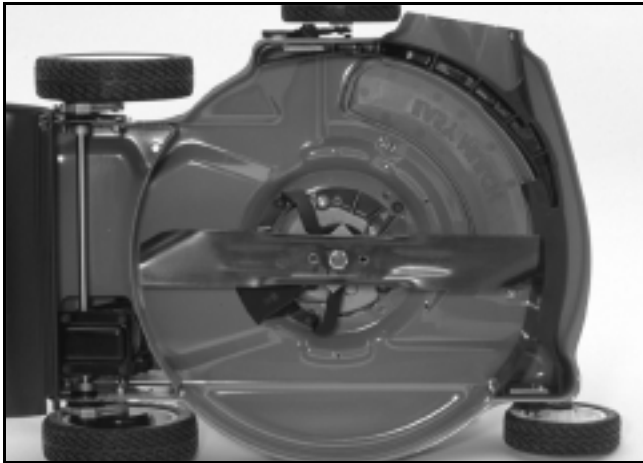

Figure 6

0893-011

(Snowthrower) Remove 2 bolts holding the muffler to the engine block. Remove the muffler. Proceed to step 3.

2. Remove the cover and the exhaust pipe under the cover. (See Figure 7.)

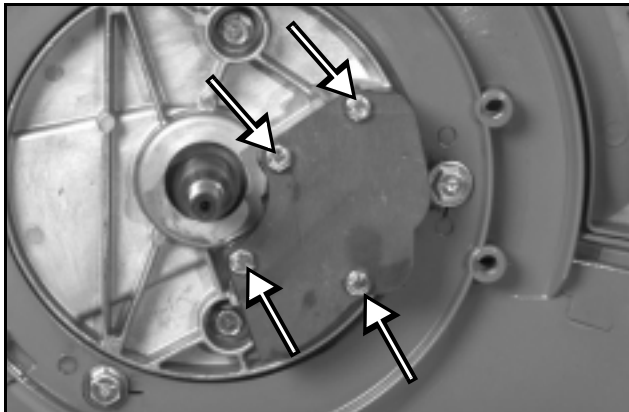

Figure 7

1657-010

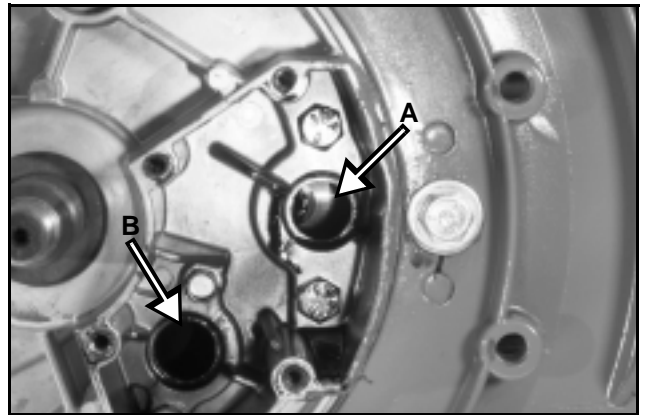

Figure 8

1657-001

3. With the cover and exhaust pipe removed, you can see into the passage leading to the exhaust port of the engine (A) and passage to the muffler (B). If the exhaust requires cleaning, remove the engine and separate the engine and base for access to the exhaust ports. If the muffler requires cleaning, it can be removed by removing the 2 screws on either side of the muffler passage (see Figure 8) and one through the side of the muffler (see A in Figure 9). Use a stick of wood to scrape the carbon loose. Do not use a metal scraper.

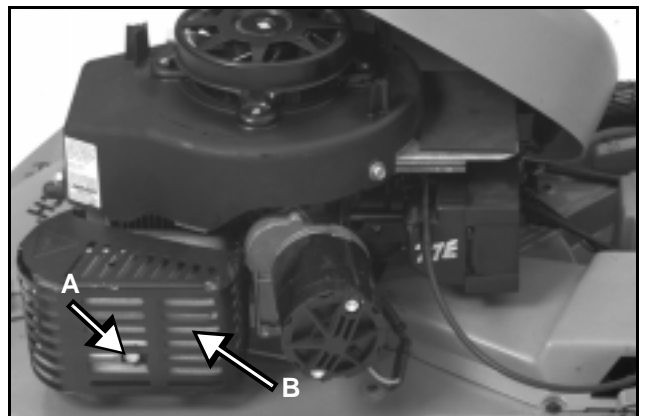

Figure 9

16057-009

4. The muffler (B) can be removed from the top of the mower to inspect for carbon buildup. (See Figure 9.)

# MAINTENANCE

## ***Cleaning the Exhaust System (Snowthrower)***

1. Remove the muffler (see Figure 10.) Clean as needed.



**Figure 10** 0893-012

2. Inspect exhaust port (see Figure 11). If cleaning is necessary, rotate piston to cover exhaust port, and scrape carbon from exhaust port area. Use wood only to clean this area.

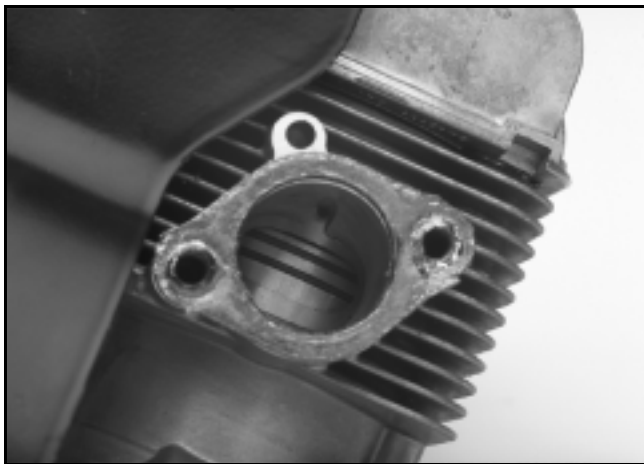

**Figure 11** 0893-035

3. Install the muffler and torque the bolts per specifications.

## ***Reassembling Exhaust System (Mower Only)***

1. Install the exhaust pipe into the engine base (see Figure 12).



**Figure 12** 16547-006

2. The cover on the exhaust portion of the engine base uses a high temperature silicone to seal the joint. Apply a coat of Loctite 598 or equivalent to the sealing surfaces before assembly. Torque the four screws per specifications.
3. Re-install the blade and mulch fan, if removed. Tighten the nut per specifications.

## Identification

The E series engines use two versions of the primer start carburetor. One with an air filter box on the mower engines (DuraForce) and one without an air filter box on the snowthrower engines (R tek). Differences include a plug in the snowthrower carburetor vent passage and some minor differences in the throttle shafts, jetting and throttle valve bleed hole. Both carburetors have two circuits and use both a choke and primer for starting. (See Figure 13.)

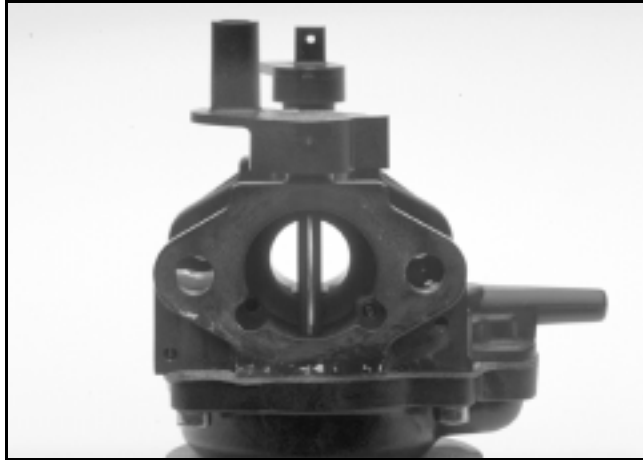

Figure 13

0720-012

## Theory of Operation

As the crankshaft rotates, the piston moves back and forth in the cylinder, alternately creating a pressure or a partial vacuum in the crankcase. (See Figure 16.)

As the piston moves toward the spark plug, the reed valve opens (see Figure 15) or the inlet ports are uncovered (see Figure 16). This causes air to rush through the carburetor throat to equalize the pressure in the crankcase. The carburetor throat is formed into a venturi (large at each end but with a smaller center passage). When air rushes through the venturi, air pressure at the center of the passage is lowered.

By inserting a tube from the carburetor float bowl into the venturi (see Figure 14), the lower air pressure at the venturi causes the normal air pressure in the bowl to push fuel up the tube.

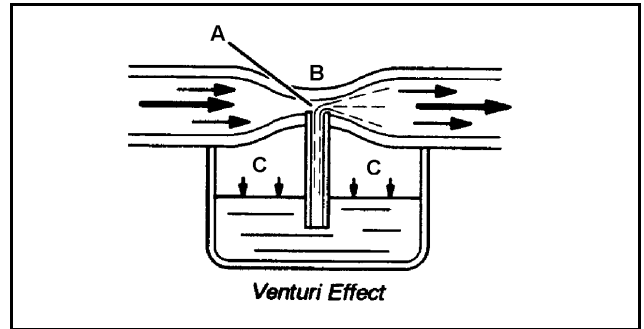

Venturi Effect

Figure 14

3297-012

- A. Venturi
- B. Center Passage Area
- C. Air Pressure

The fuel/oil mix is then picked up by, and mixed with, the moving air, the amount of fuel determined by throttle opening and jet size. This fuel/oil/air mixture enters the crankcase through the reed valves (DuraForce), or ports (R tek). (See Figure 15 and Figure 16.) When the piston moves away from the spark plug, the cylinder intake ports are opened and the now pressurized crankcase causes the mixture to move into the combustion chamber.

## Reed Valve

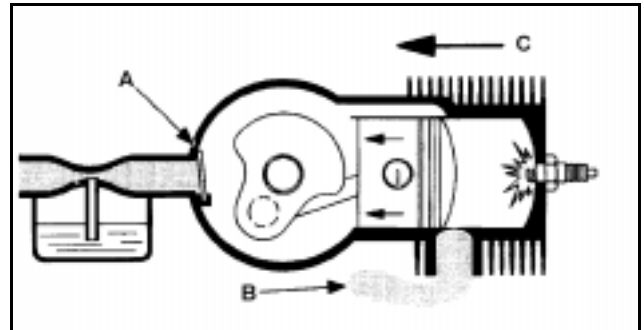

Figure 15

3297-021-3

- A. Reed Valve Closed
- B. Exhaust Gases
- C. Second Stroke

## Piston Ported

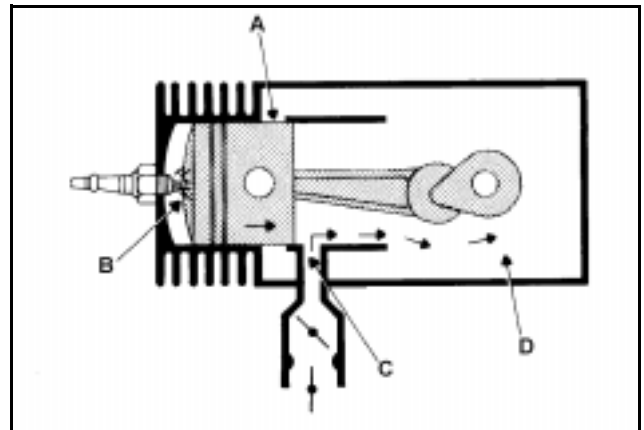

Figure 16

3297-002

- A. Intake Ports Closed
- B. Ignition
- C. Third Port Open
- D. Partial Vacuum



# CARBURETOR

---

## Troubleshooting

### Engine Starts Hard

Possible Causes	Remedies
Primer malfunction	Repair or replace as necessary
No fuel in carburetor	Add the proper fuel-oil mix
Carburetor bolts loose	Tighten bolts to 20 - 30 in.lbs. (2.2 - 6.2 Nm)
Mislocated gaskets	Loosen bolts, realign gaskets, and tighten
Choke not closing fully	Adjust choke or throttle/choke cable

### Engine Runs Rich

Possible Causes	Remedies
Dirty air cleaner	Clean or replace and re-oil air filter element (DuraForce engines)
Dirt in carburetor	Clean carburetor, fuel line and tank
Primer line pinched	Inspect and correct problem
Dirt in primer vent	Clean and/or replace as necessary
Choke not opening fully	Adjust choke or throttle/choke cable

### Engine Runs Lean

Possible Causes	Remedies
Carburetor bolts not tight	Tighten bolts to specifications
Crankcase gaskets or seals leaking	Replace or reseal
Main jet partially clogged	Clean jet
Pilot jet or circuit clogged	Clean pilot jet and passages

### Fuel Leaks From Carburetor (Leaking is continuous and fully drains fuel tank)

Possible Causes	Remedies
Dirt under inlet needle	Remove inlet needle and seat. Then clean or replace and pressure check.
Bowl vent plugged	Remove bowl and clean with compressed air
Float sinking (heavy)	Replace float
Float stuck (gummed carburetor)	Remove bowl and clean carburetor

## Fuel Leaks From Carburetor (Leaking starts after running, stops after shutdown)

**Note:** This condition which does NOT drain the fuel tank is called “spit-back”.

Possible Causes	Remedies
Engine RPM out of proper range	Adjust to proper range (experimentation within the RPM range may be necessary)
Exhaust partially plugged	Decarbon exhaust port and muffler
Rings leaking	Break in new engine or repair worn rings/cylinder
Float height incorrect	Re-set float
Reeds not sealing	Repair/replace reeds (DuraForce only)

### Preliminary Check

The primer start carburetor used in E Engines has an all Minlon housing with a fixed high speed and pilot jet and an adjustable float.

Perform the following preliminary checks to eliminate some of the possibilities that may contribute to carburetor malfunction:

1. Ignition system - ensure that all components are adjusted to specs and are the correct components.
2. Fuel tank filter - must not be plugged.
3. Fuel cap vent - hole must not be plugged.
4. Air filter - must be clean and oiled (DuraForce engines).
5. Crankcase seal - Crankcase seals must be installed properly and in good condition; torque value on the bolts must be correct.
6. Carburetor flange gaskets and heat shield - must be installed correctly.
7. Exhaust ports - must not be restricted.
8. Fuel - mixture must be fresh. As gasoline ages, it becomes more difficult to ignite.
9. Governor air vane - must move freely.

### Removal of DuraForce Carburetor

1. Disconnect spark plug wire. We strongly recommend cleaning the exterior of the carburetor before removal from the machine. This reduces the chance that dirt can get into the carburetor and will extend the life of the solvent in your cleaning tank.
2. Remove fuel line and drain; remove the fuel tank. On snowthrowers, it will be necessary to remove the lower shroud to access the carburetor and fuel line.
3. Open and remove air cleaner cover and air filter element (mower only). (See Figure 17.)
4. Detach carburetor from engine by removing two mounting screws. Discard the two smaller carburetor gaskets on either side of the carburetor shield. Keep the heat shield for later installation. (See Figure 17.)

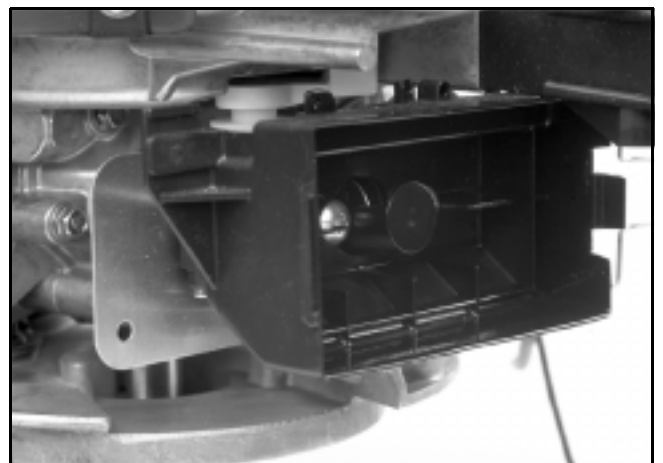

**Figure 17**

0893-045

# CARBURETOR

5. Disconnect the primer tube from the carburetor fitting. (See Figure 19.)
6. Pull the carburetor assembly down and away from the engine such that the air vane governor clears the hole in the shroud mounting base.
7. Remove the throttle cable screw and nut from the throttle cable mounting bracket.

**CAUTION:** Be careful in the next step to avoid damage to the delicate governor spring.

8. Slide the plastic control lever to either end of its adjustment and snap it to the locked position to help restrict its movement while you disconnect the throttle cable from the control lever.

## **Removal of R tek Carburetor**

1. Disconnect spark plug wire. We strongly recommend cleaning the exterior of the carburetor before removal from the machine. This reduces the chance that dirt can get into the carburetor and will extend the life of the solvent in your cleaning tank.
2. Remove fuel line and drain; remove the fuel tank. On snowthrowers, it will be necessary to remove the lower shroud to access the carburetor and fuel line.
3. The carburetor is attached to the intake pipe by two screws, which are screwed into two captured nuts. The nuts are held in their pockets by a rubber band during the manufacturing process. If the rubber band is no longer in place, smear some general purpose grease on the nuts to prevent them from falling out of the pockets. Remove the two screws and discard the gasket. (See Figure 18.)

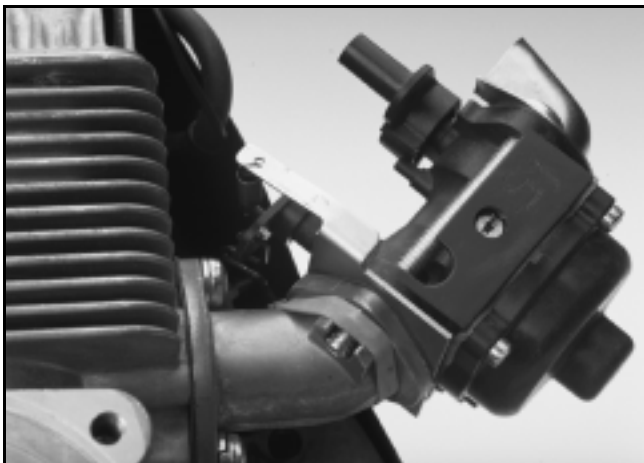

**Figure 18**

0893-009

4. Disconnect the primer tube from the carburetor fitting (see Figure 19).
5. Disconnect the governor spring from the adjustment arm, and remove the choke cable. (See Figure 19.)



**Figure 19**

0893-039

6. Pull the carburetor assembly down and away from the engine such that the air vane governor clears the hole in the shroud mounting base.

## **Disassembly**

1. **NOTE:** The exterior of the carburetor should be cleaned before removal from the machine. If this has not been done, clean the outside before disassembly. At the throat of the carburetor, using needle nose pliers, gently pull the throttle plate out of the throttle shaft. (See Figure 20.) Notice the orientation of the small protrusions on the throttle plate as you pull it out.

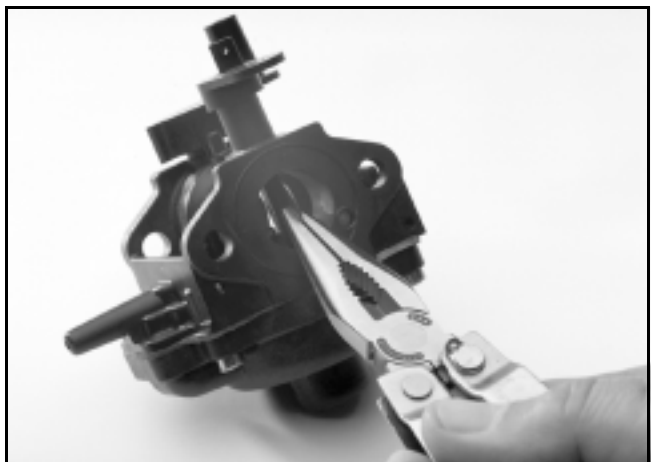
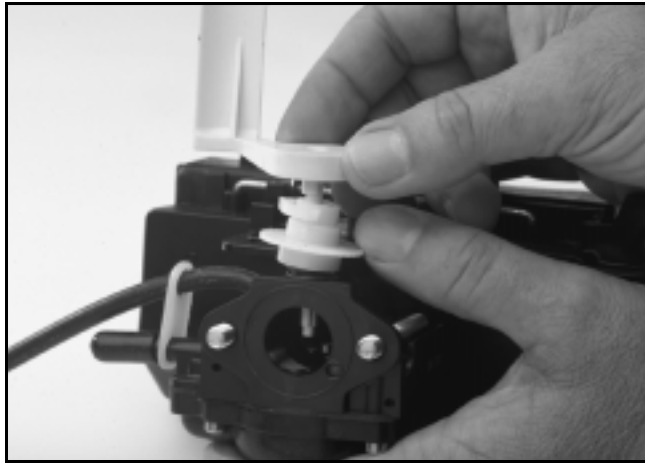

**Figure 20**

0893-007

# CARBURETOR

2. Hold the governor collar on the carburetor and lift the air vane/throttle shaft out of the carburetor. For DuraForce engines only - Lift the collar and spring up, detaching the spring from the speed control lever. (See Figure 21.)



**Figure 21**

0893-005

3. Turn the carburetor over. Remove the four bowl retaining screws, the bowl gasket, and the bowl. (See Figure 22.) Discard the bowl gasket.

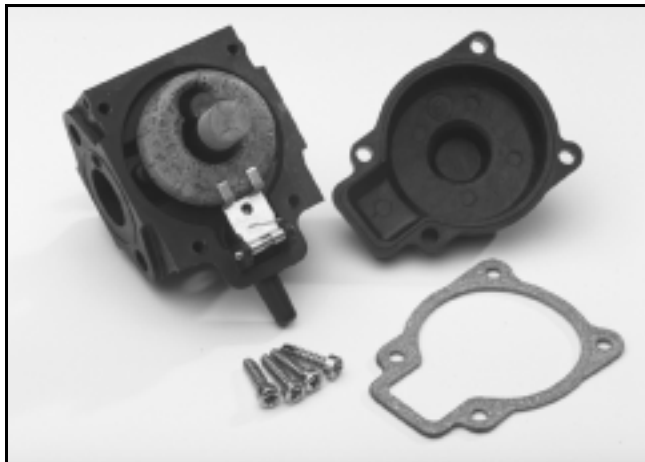

**Figure 22**

0893-002

4. The pilot jet is located under the decal on the side of the carburetor. Remove the decal and the pilot jet. Note: The threads have Loctite on them. (See Figure 23.)

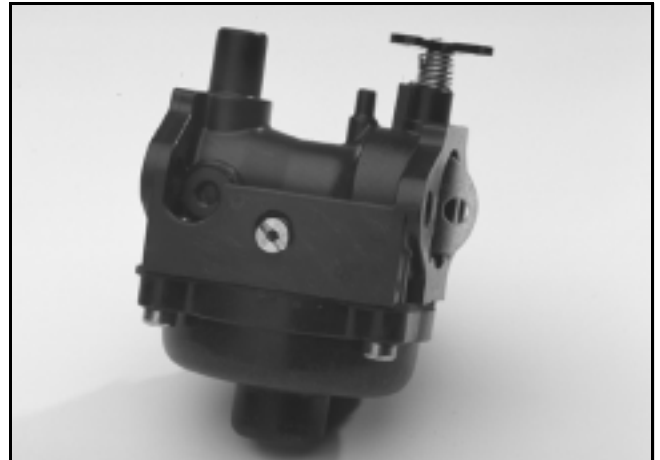

**Figure 23**

0893-30

5. Remove the fuel filter from the fuel nozzle (see Figure 24).

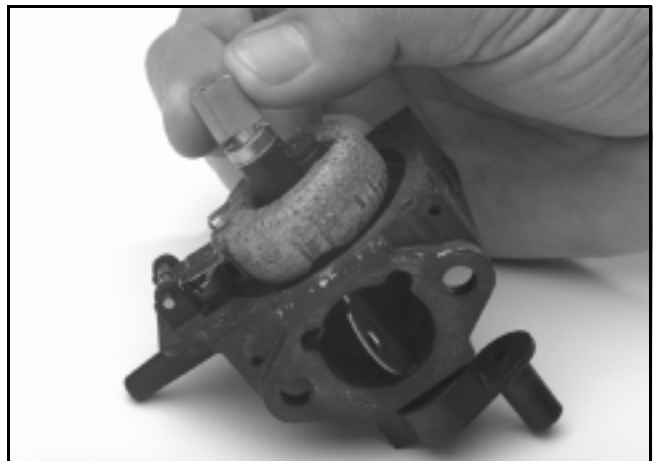
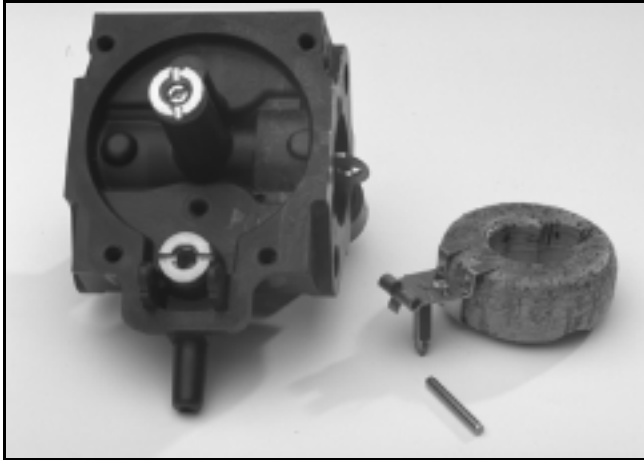

**Figure 24**

0893-22

# CARBURETOR

- Remove the float hinge pin, the inlet valve needle assembly (with its clip), and the float (see Figure 25). Discard the needle and clip.



**Figure 25** 0893-18

- Inspect the float for cracks or deterioration of the cork (see Figure 26).



**Figure 26** 0893-001

- Remove the brass inlet fuel valve seat and discard it. (See Figure 27.)

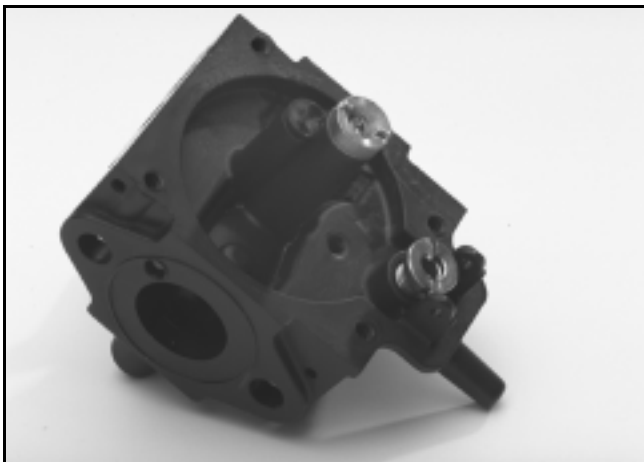

**Figure 27** 0893-041

- Remove the high speed jet (A) from the nozzle (B). It is best to clean the nozzle in place. If the nozzle is not sealed into the carburetor body, the air/fuel mixture will be affected (see Figure 28).

Note: There are two white nylon plugs in each carburetor. Do not attempt to remove them or the carburetor will be damaged.

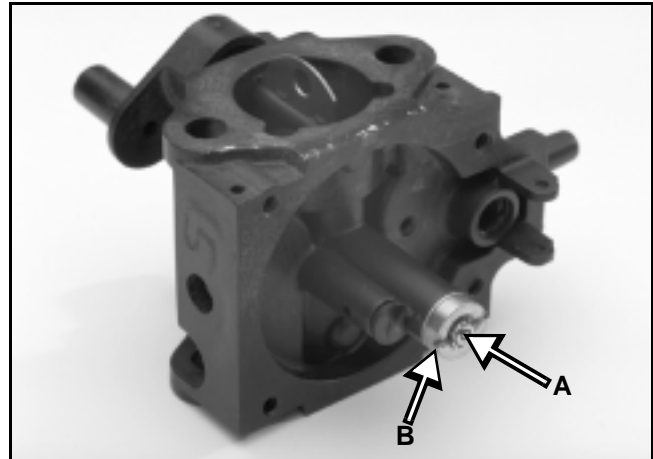

**Figure 28** 0893-037

## ***Cleaning and Inspection***

- With the carburetor completely disassembled, thoroughly clean all parts in a parts cleaning solution. Do not soak the carburetor. Leave it in the solvent only long enough to clean it. Inspect for wear or deterioration. Use a spray can of carburetor cleaner with the hose, and flush all passages with cleaner. Blow dry all carburetor passages with compressed air.

CAUTION: If tag wire is used, never enlarge or restrict any passageway in the carburetor.

- Always check the carburetor mounting flange and the fuel bowl mounting flange to be sure they are smooth and undamaged.

## Assembly

1. Install the high speed jet into the fuel nozzle.
2. If the nozzle has been removed, turn the carburetor over. Apply one drop of Loctite 242 blue or equivalent to the nozzle threads, and install the nozzle assembly into the carburetor body (see Figure 29).

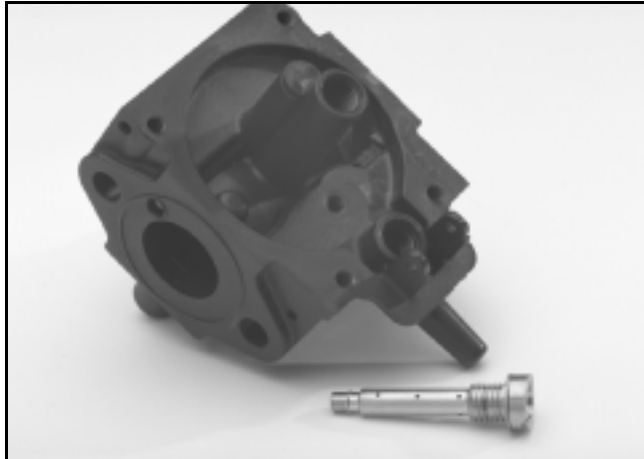

**Figure 29**

0893-038

3. Apply one drop of Loctite 242 blue to the threads, and install the pilot jet (see Figure 30).

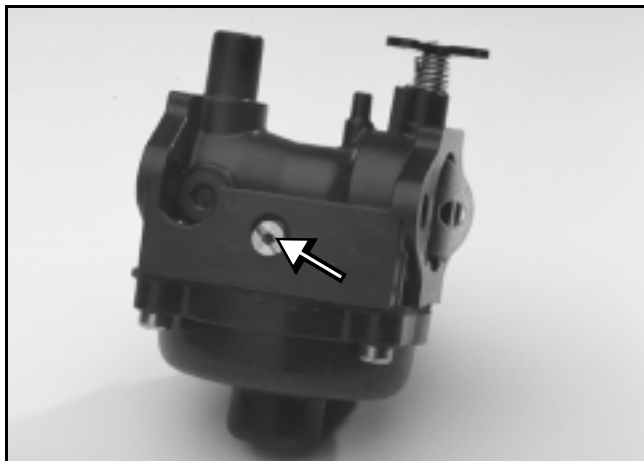

**Figure 30**

0893-030

4. Apply one drop of Loctite 242 or equivalent to the seat threads, and install a new brass inlet fuel valve seat (see Figure 31).

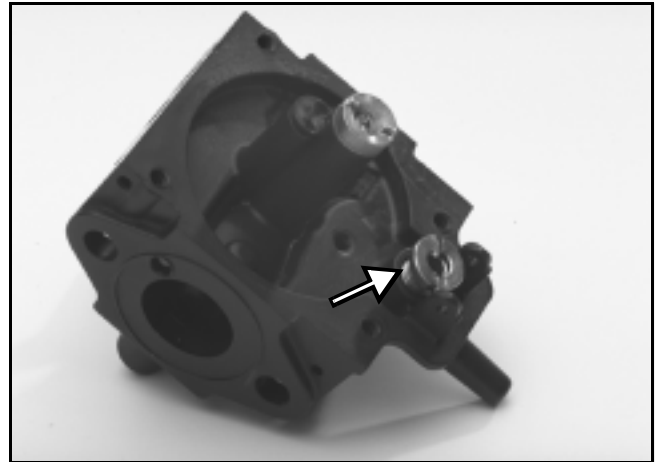

**Figure 31**

0893-041

5. Install a new inlet valve needle and clip on the float.
6. Install the float assembly with a new float hinge pin in the bottom of the carburetor. Ensure that the hinge pin is positioned properly to keep the float level. The float should be free to move up and down easily in the carburetor body.
7. Adjust float so height is  $1/2 \pm .03$ " (.76 mm) from bowl flange (gasket not in place) to top of float (see Figure 32).

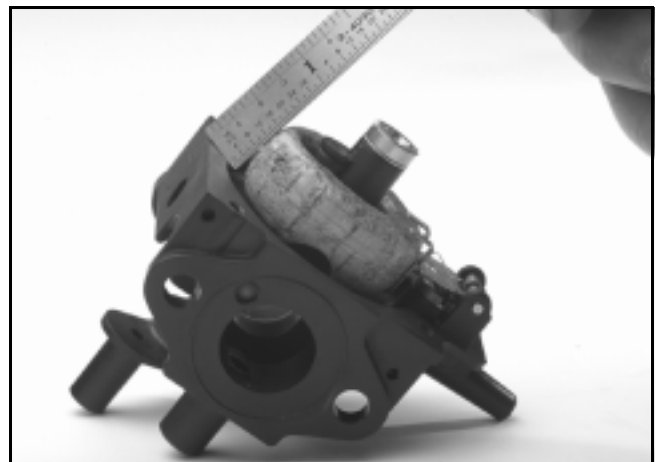
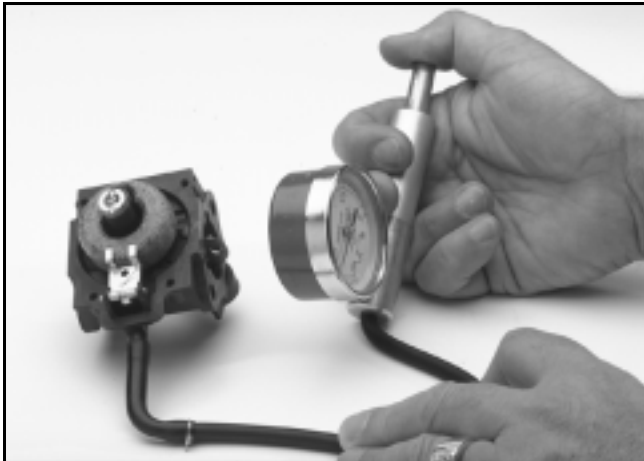

**Figure 32**

0893-054

# CARBURETOR

8. Pressure check carburetor. Attach pump with pressure gauge to fuel inlet fitting on carburetor (see Figure 33). With carburetor upside down (float up), raise float and lower to its normal position. Pump pressure to 5 psi. It should hold this pressure indefinitely. For practical purposes, test for 10 or 15 seconds. If it does not hold, wet the needle and seat, and repeat the test.



**Figure 33** 0893-026

9. Install the fuel filter over the fuel nozzle. Pressure check before proceeding (see Figure 34).



**Figure 34** 0893-22

10. Install a new fuel bowl gasket and the fuel bowl with the four bowl retaining screws (see Figure 35).

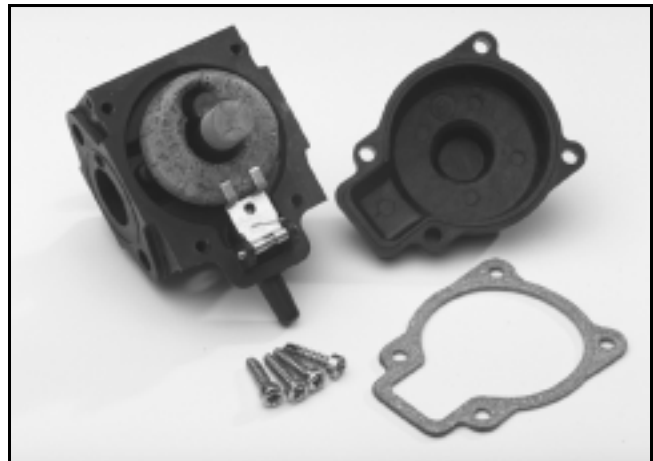

**Figure 35** 0893-002

11. Hook the governor spring into the bottom of the governor collar (DuraForce engines). See Figure 36.

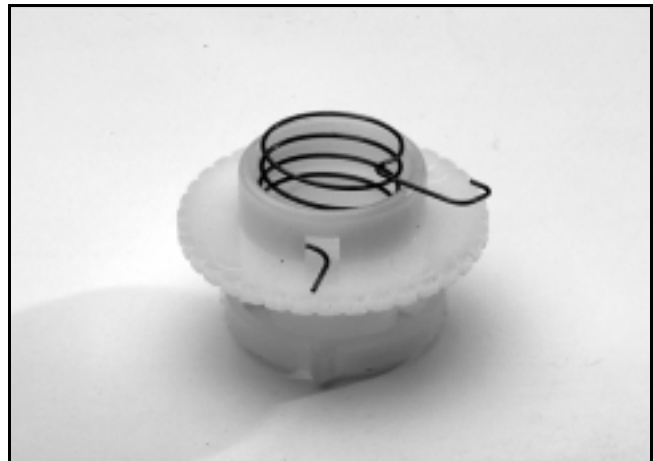

**Figure 36** 0893-050

12. Place the collar and spring over the carburetor fitting (DuraForce engines). See Figure 37.



**Figure 37** 0893-005

13. Install the air vane and throttle shaft into the carburetor body by very carefully pushing the shaft through the collar into the carburetor body. (See Figure 37.)
14. Push the throttle plate into the throttle shaft. (The plate only inserts one way.) If the throttle plate does not fit snugly, replace the throttle shaft. The governor spring can now be attached to the throttle shaft.

Note: Be sure air vane operates smoothly and does not stick or bind.

## Installation

1. DuraForce - Assemble the carburetor, gaskets, heat shield, and air filter box. Use the two mounting screws to hold the parts together during assembly.  
  
R tek - Assemble the carburetor, spit cup, heat shield, and gaskets. Use the mounting screws to hold parts together during assembly.
2. DuraForce engines - Guide the air vane through the opening in the shroud base from the bottom of the base, and attach the carburetor to the engine with two mounting screws. Tighten them to specifications.
3. DuraForce engines - Insert the bent wire of the throttle cable into the vertical tab of the speed control lever. Set the throttle to fast and the speed control lever so that the throttle plate is in the full open position. The cable is adjusted at the cable clamp on top of the air filter box.

R tek engines - Connect the governor spring to the throttle plate and the tab on the block. Connect the governor rod adjusting loop (A) up to the air vane, and connect the choke cable. Assure the throttle is in the full open position. (See Figure 38 and Figure 40.)

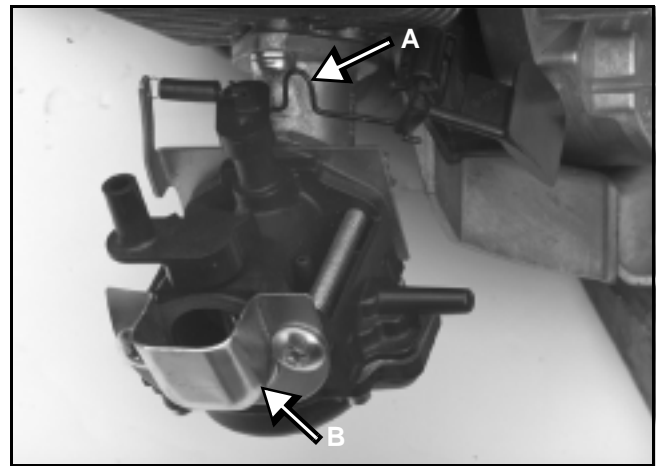

Figure 38

724-004

4. Install the fuel line and primer tube on the appropriate carburetor fittings.
5. Check that the choke and air vane assembly move freely and is properly adjusted. If the air vane requires adjusting, see Presetting the Governor on page 26.
6. Install the air filter element and cover (DuraForce engines only). The R tek engine has a spit cup (B) only. Note: The opening of the spit cup should be pointed up. (See Figure 38.)

## Governor Theory

### Reed Valve Engine (DuraForce Engines Only)

The shaft of the governor air vane is attached to the throttle disc of the carburetor so that air flow, created by the rotating flywheel, attempts to close the throttle. The governor spring resists this force and attempts to open the throttle. The balance between these two forces is the governed engine speed. Spring tension may be changed via an adjustable collar which produces a 50 - 75 RPM change in engine speed for each adjustment "click" it is moved. (See Figure 39.)



# CARBURETOR

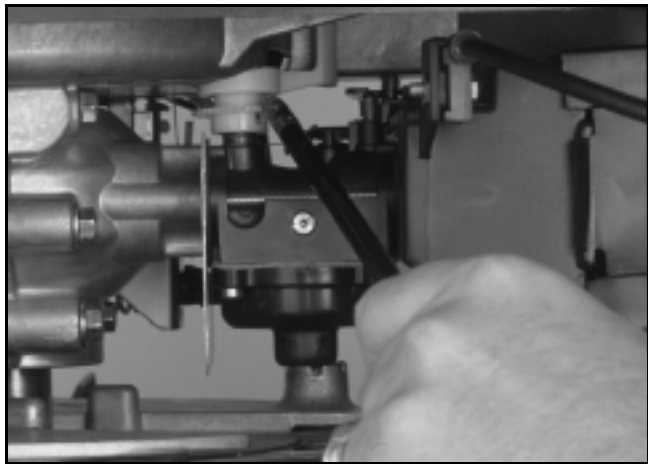

Figure 39

0720-07

## ***Piston Ported Engine (R tek Engines Only)***

The piston ported engine does not use the “click” type adjustment. For the piston ported engines, the governor is adjusted by bending the bracket that the governor spring is attached to. Otherwise, the function of the governor is the same (see Figure 40).

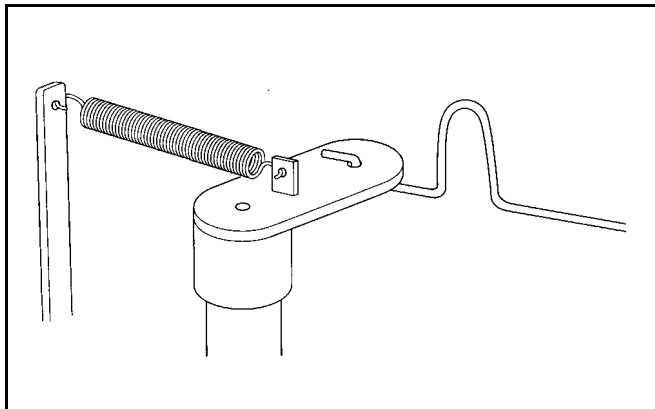

Figure 40

3S-001

## ***Presetting the Governor (DuraForce Engines Only)***

Note: Each “click” of the governor collar represents approximately 50-75 RPMs.

1. Turn the collar clockwise to increase spring tension (and engine RPMs) or counterclockwise to decrease spring tension and RPMs. (See Figure 39.) Preset the governor collar 3 or 4 clicks clockwise.

2. Use a tachometer to check engine speed;  $2900 \pm 300$  RPM for DuraForce engines on mowers.

For R tek (piston ported) engines refer to the specification pages.

Should the governor link (A) be bent or replaced, adjustment will be necessary. (See Figure 41.)

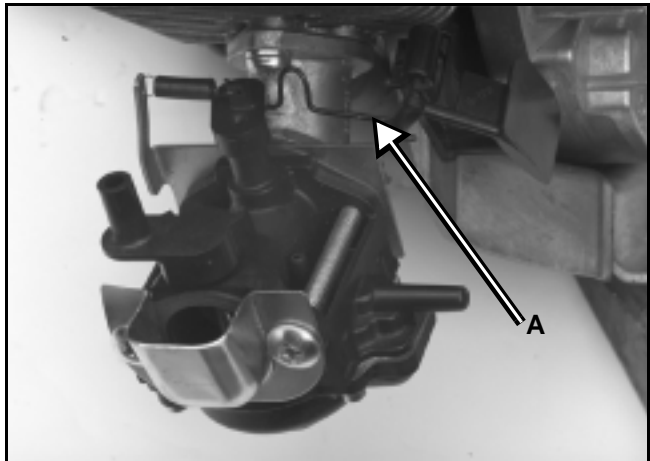

Figure 41

0893-039

A good starting point is about  $1\frac{1}{4}$ ” (31.75 mm) from the casting to the end of the air vane. (See Figure 42.) Then move the air vane until the throttle is full open. The air vane must not contact the CD ignition. Should the governor spring be removed, reinstall with both the open ends of the spring facing you.

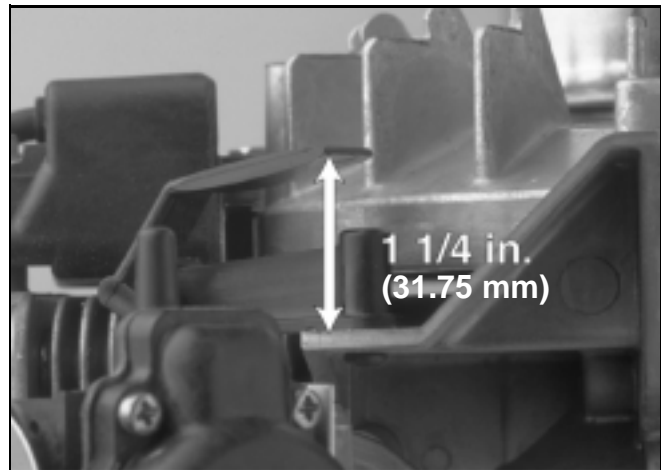
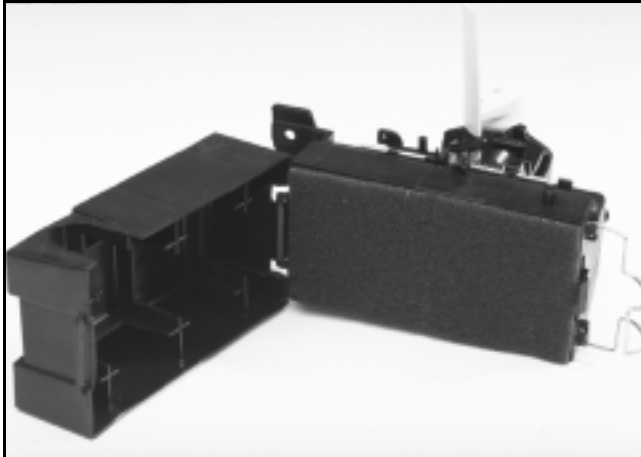

Figure 42

7.tif

## ***Servicing the Air Filter (DuraForce Engines Only)***

1. To remove the air filter, unsnap the wire holder on the right side of the cover the cover. Rotate the cover open. The air filter element can now be removed. If you wish to remove the cover, rotate it full open and unhook it from the hinge. (See Figure 43.)



**Figure 43**

0893-017

2. Clean and re-oil the air filter element according to the procedure in Maintenance section.

**CAUTION:** Do not operate the engine without a filter element or with a dry element; engine life will be shortened.

**Note:** Snowthrower engines do not have an air filter for two reasons:

- a. The snow prevents dirt from getting into the air.
- b. In colder weather, the snow will blow around. Fine particles of snow would clog the air filter. The engine will ingest snow, but that small amount will not cause a problem.

**THIS PAGE INTENTIONALLY LEFT BLANK**

## Operation

The E engine uses a plastic fuel tank with a non-replaceable 75 micron in-tank filter screen. The filter is welded in the bottom of the tank over a sediment reservoir. The tank is mounted above the level of the carburetor and uses gravity to supply fuel through a .25" I.D. (6.35 mm) rubber hose to the carburetor. The fuel hose is friction-fitted to the tank outlet at one end and to the carburetor at the other end.

The fuel tank is vented through an opening in the fuel cap. The fuel opening on the tank is opposite the fuel outlet, helping to prevent damage to the filter screen by funnels and gasoline filler spouts that may be inserted into the fuel tank during refueling. The placement of the cap also prevents interference with the starting rope in Zone Start mower applications.

The fuel cap is a four piece design (see Figure 44) with an inner sealing disc that is vented to a baffle assembly in the body of the cap. The baffle assembly allows expansion in the tank or splash against the bottom of the cap, without the loss of fuel. Atmospheric pressure is allowed into the tank from an opening in the cap to allow gravity to feed fuel to the carburetor. (If an individual part of the cap fails, the entire assembly must be replaced.)

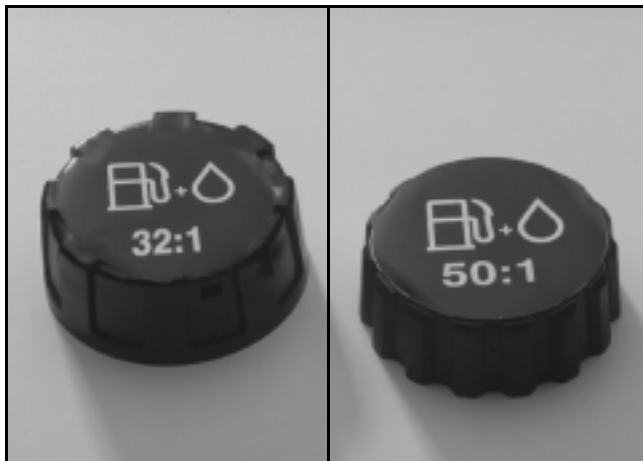

Figure 44

0720-022

## Fuel Cap Service

1. The fuel cap may not be disassembled; however, the vent opening on the cap and inner sealing disc should be kept free of debris.
2. The venting ability of the cap may be tested by filling the cap with water and observing the flow of water out of the vent opening in the top of the cap. If water does not drain, the vent opening may be plugged or restricted.
3. If the fuel cap will not vent properly, replace the entire cap assembly.
4. Should you encounter a situation where fuel leaks around the threads of the fuel cap (not out the vent), inspect the top of the neck of the fuel tank and the area in the cap where the fuel tank neck contacts the cap. This is the sealing area, not the threads. (See Figure 45.)

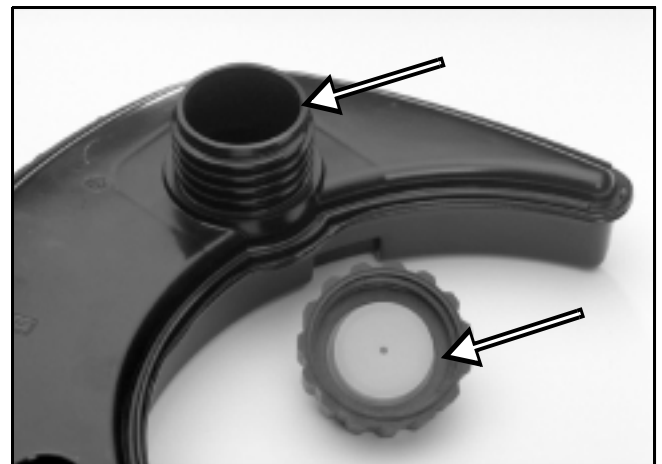

Figure 45

720-021

## Cleaning

1. Remove the fuel tank. Take it to an appropriate area, and wash the tank in clean solvent intended for cleaning engine parts.
2. Backwash the filter screen by directing cleaning solvent, under moderate pressure, through the sediment reservoir and screen, opposite the direction of fuel flow.
3. Wash the tank again with clean solvent.
4. Clean or replace the fuel hose.

**THIS PAGE INTENTIONALLY LEFT BLANK**

## Troubleshooting

Problem	Possible Cause	Suggested Remedy
Misfiring, no firing, engine surges, engine dies (Note: these symptoms may also be caused by fuel system problems)	Spark plug or lead wire loose	Tighten plug
	Spark plug in poor condition	Replace plug
	CD Pack air gap wrong	Adjust
	CD Pack high tension lead loose	Secure with GE silicon sealant
	CD Pack leads loose, dirty, or grounding	Clean and tighten leads/replace
	CD Pack defective	Replace CD Pack
	Flywheel key damaged or sheared	Replace key and check keyway (see Servicing the Flywheel in this section)
	Flywheel magnets demagnetized or weak	Replace flywheel
Engine will not stop	Broken ground wire	Check the ground wire between the mag and kill switch. Look for breaks or loose connections.

## Testing

Check the ignition system in the following order:

1. Spark plug (connection & wire, condition).
2. CD Pack (air gap, connections or spark).
3. Flywheel (key and magnets).

Use the table above to aid in diagnosing the problem.

## Spark Plug Operation

The spark plug ignites the oil-fuel mixture by producing a spark just before the piston reaches top dead center (TDC). A spark plug is typically constructed as shown. (See Figure 46.)

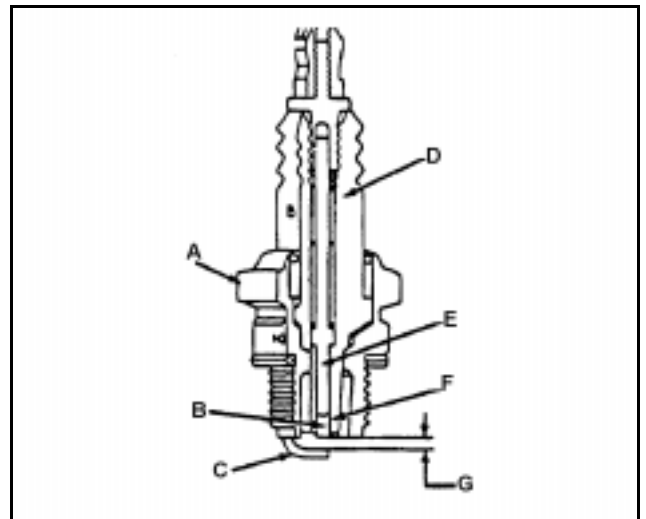

**Figure 46**

3297-014

- |                     |                   |
|---------------------|-------------------|
| A. Metal Shell      | D. Head Insulator |
| B. Center Electrode | E. Copper core    |
| C. Ground Electrode | F. Leg Insulator  |
|                     | G. Gap            |

# IGNITION SYSTEM

## Spark Plug Service

1. Check spark plug with the chart in this subsection and replace following the specifications given on this page.

CAUTION: Do not clean plug with a sand blaster.

2. Clean with a wire brush removing the carbon buildup. Check conditions of the plug for cracking or damage. Replace as necessary.

Item	Specification/Action
Plug type	NGK BPMR4A or equivalent
Frequency of change	As needed
Check, clean, and gap	Every 50 hours
Gap	See specifications
Torque value	See specifications

## CD Pack Operation

The Capacitive Discharge (CD) system (see Figure 47) is breakerless and contains electronic components that replace mechanical points and related accessories (such as a breaker cam, spark advance assembly, etc.).

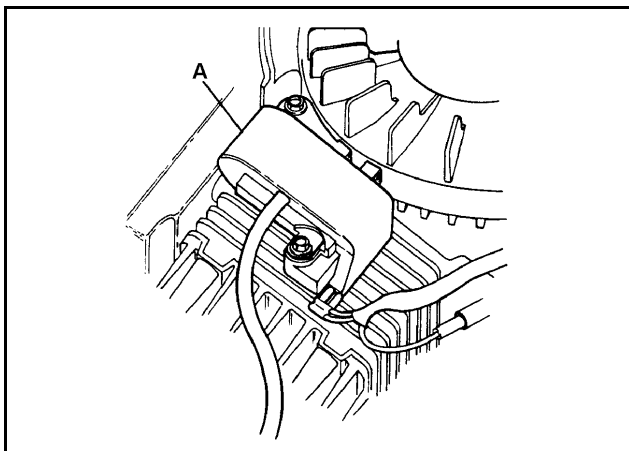

Figure 47

3297-015

A. CD Ignition Module

As the flywheel magnet passes the CD Pack, an AC voltage is induced into the charge coil. This AC voltage is converted by a rectifier into a DC signal, which is then stored in a capacitor. (See Figure 48.)

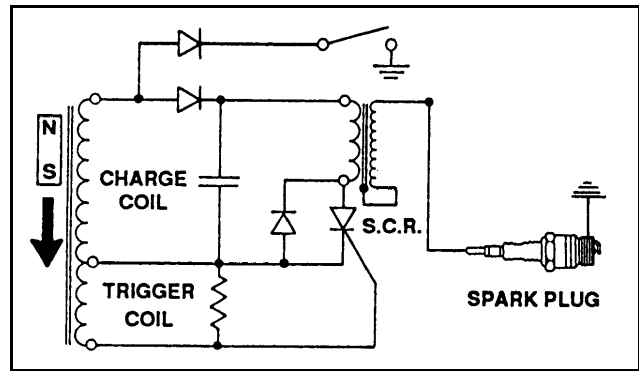

Figure 48

3297-016

When the SCR is triggered or “fires”, up to 200 volts DC, stored in the capacitor, travels to the spark coil. Here it is stepped up to as much as 25,000 volts and is discharged across the electrodes of the spark plug. (See Figure 49.)

Ignition timing (when the SCR fires) is also determined by the flywheel key and the keyways in the flywheel and crankshaft. Damage to any of these parts will affect the ignition timing.

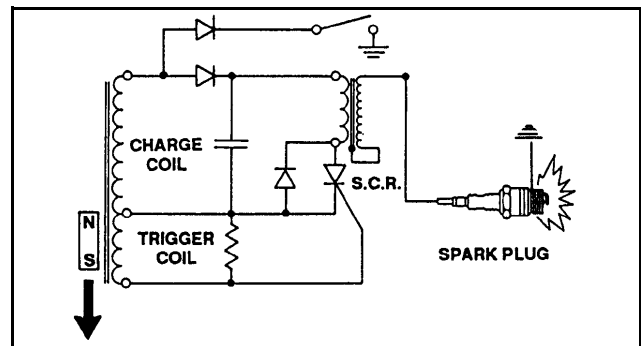
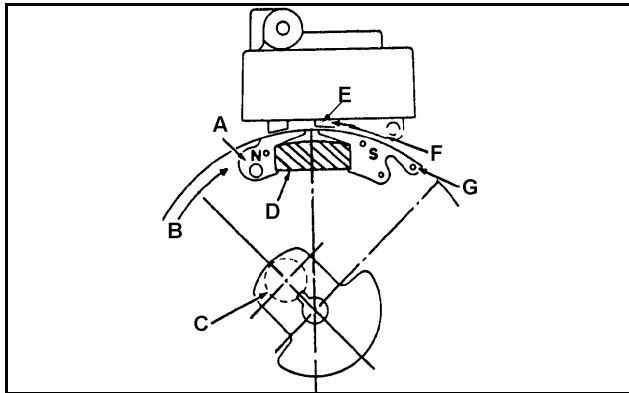

Figure 49

3297-017

At slower speeds, the flywheel magnet induces a smaller charge in the trigger coil. This action triggers the silicon controlled rectifier (SCR) enabling easier starting in a “retarded firing position” about 5 degrees before top dead center (BTDC). (See Figure 50.)

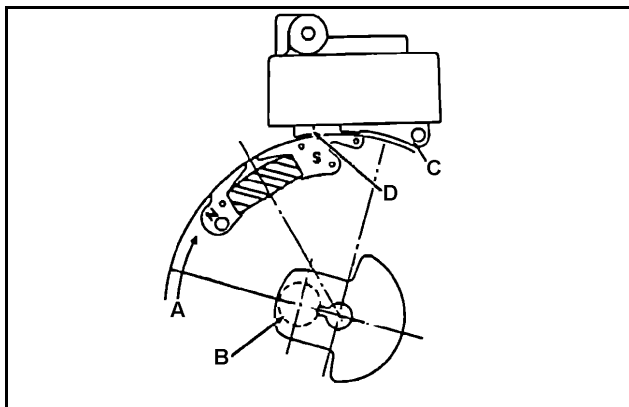

**Figure 50**

3297-018

- |                          |                 |
|--------------------------|-----------------|
| A. Pole Shoe             | D. Magnet       |
| B. Flywheel Rotation     | E. Starting Leg |
| C. Crankshaft at 5° BTDC | F. Charging Leg |
|                          | G. Pole Shoe    |

At faster speeds (about 800 RPM), the flywheel magnets induce a large enough charge in the trigger coil to trigger the SCR in the “advanced firing position” (about 28 degrees BTDC). (See Figure 51.)



**Figure 51**

3297-019

- |                           |                            |
|---------------------------|----------------------------|
| A. Flywheel Rotation      | C. Charging Leg            |
| B. Crankshaft at 25° BTDC | D. Running Leg 25° Advance |

## CD Pack Air Gap Adjustment

1. Rotate the flywheel until the magnets are directly adjacent to the CD Pack as shown. (See Figure 52.)

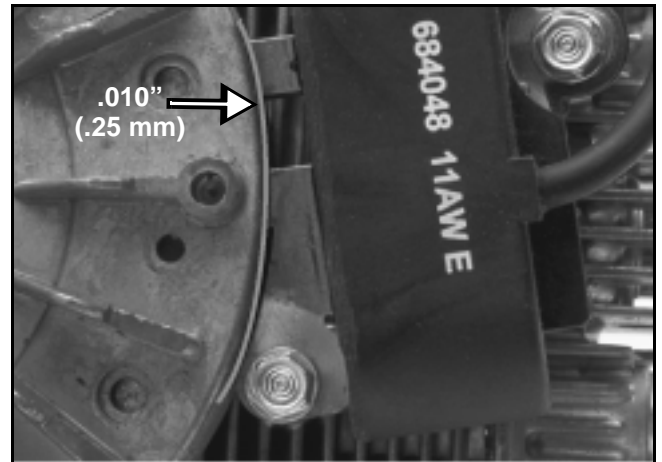

**Figure 52**

lbv0040a

2. Adjust gap by loosening screws, inserting Lawn-Boy gauge (P/N 604659) or a piece of .010" (.25 mm) shim stock and tightening screws. Remove the shim stock or gauge.

## CD Pack Removal/Installation

1. Disconnect leads and remove mounting screws.
2. Replace CD Pack, and set gap as outlined in step 1 above. Tighten screws. See specifications for torque values. (See Figure 53.)

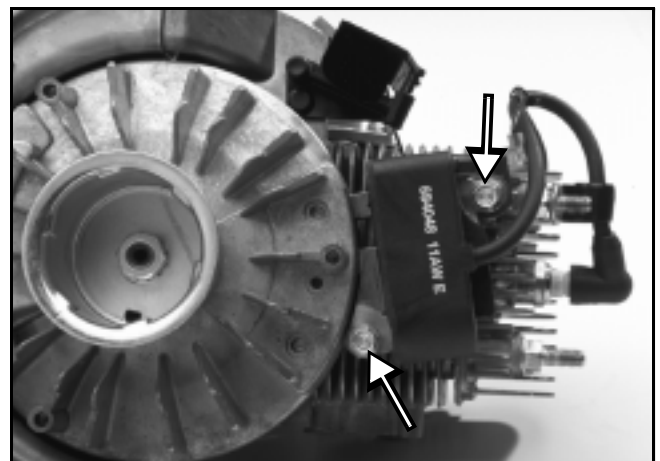

**Figure 53**

lbv0040b



# IGNITION SYSTEM

## ***Flywheel Operation***

The flywheel is connected directly to the crankshaft (secured by a flywheel key and nut) and turns at the same speed as the crankshaft. Two permanent magnets, imbedded in the flywheel, rotate past the coil in the CD Pack to begin the generation of electricity.

Imbedded in the opposite side of the flywheel are steel counterweights which offset the weight of the magnets. These counterweights are not magnetic.

A flywheel key and keyway in the flywheel and crankshaft are used to assure alignment during assembly. The tapered fit of the flywheel and crankshaft along with the torque of the bolt or nut actually holds the parts together. The surfaces of both tapers must be good to obtain a good friction fit. The key is designed as a light duty part so that if the engine stops rapidly, due to blade impact, the key will shear. If the key were too hard and the impact occurred, the more expensive flywheel could crack.

## ***Flywheel Removal***

1. Remove shroud and fuel hoses.
2. Remove flywheel nut and starter cup. Reinstall nut flush with the end of the crankshaft. (See Figure 54.)

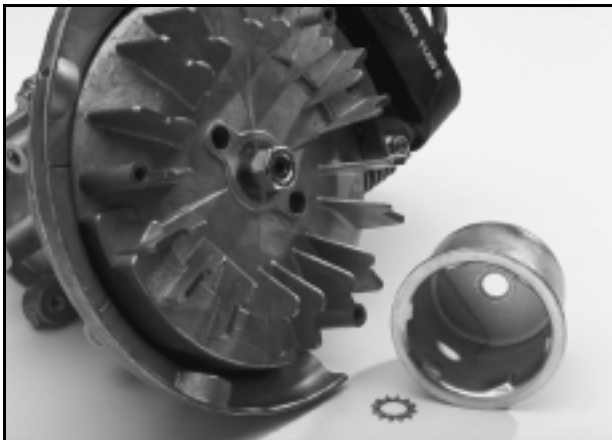

**Figure 54**

0893-21

3. Remove the flywheel by pulling up on the edge of flywheel while striking the flywheel nut with a soft hammer. (See Figure 55.)

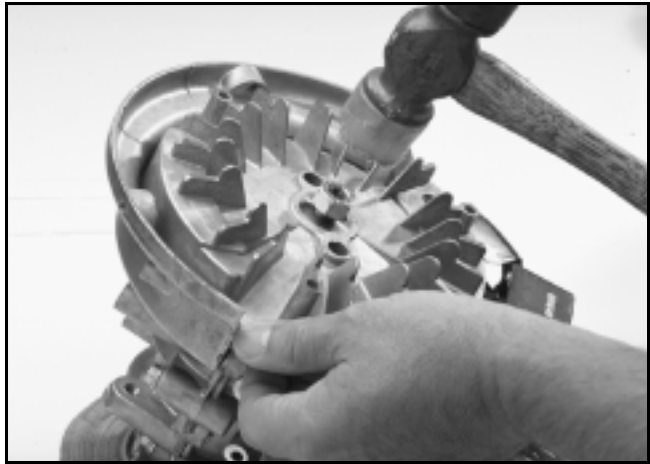

**Figure 55**

lbv0040b

4. Remove key and check its condition (see Figure 56).

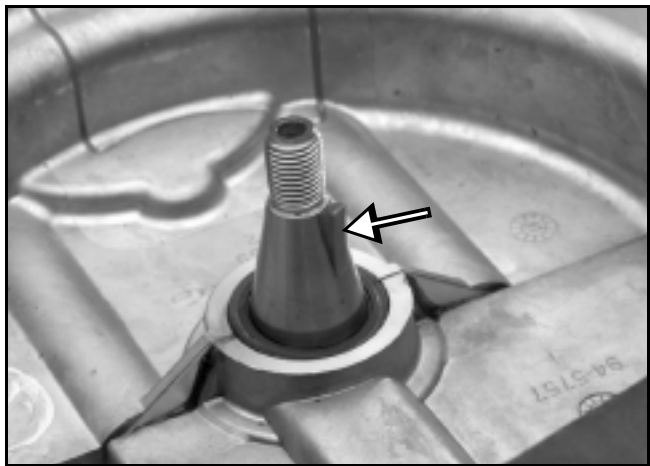

**Figure 56**

0893-006

5. Replace crankshaft and/or flywheel if keyway is distorted or cracked.

6. Inspect the flywheel for cracks or damage and the strength of the magnets using a iron object. Replace as necessary. (See Figure 57.)

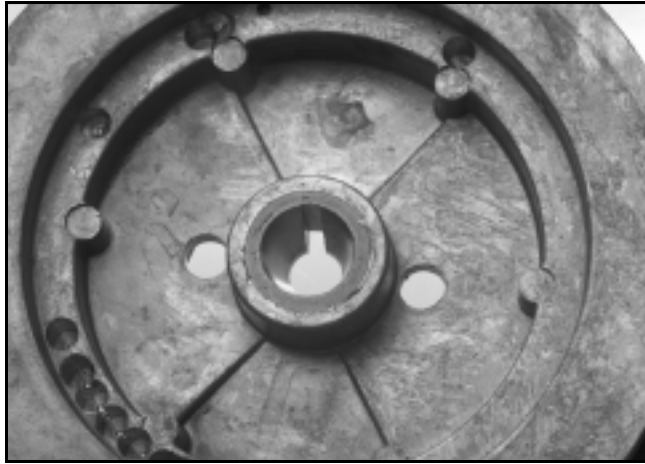

Figure 57

0893-013

4. Torque flywheel nut to specifications (see Figure 59.)

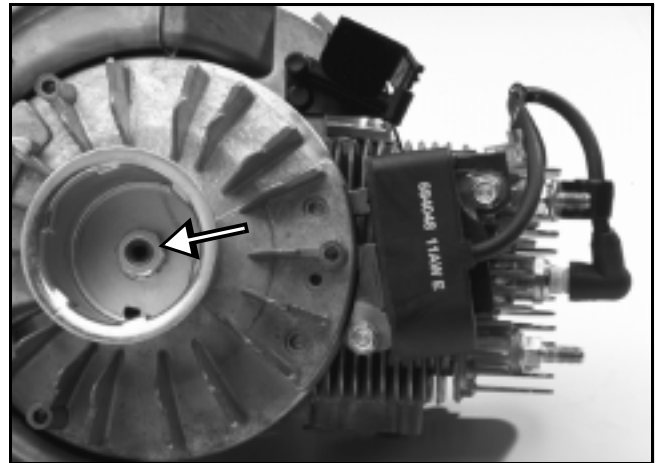

Figure 59

0893-025

## ***Flywheel Installation***

1. Make sure flywheel taper, crankshaft taper, and keyway is absolutely clean and dry.
2. Make sure key is installed correctly (see Figure 58.)
3. Locate keyway cutout in flywheel over key and shaft.

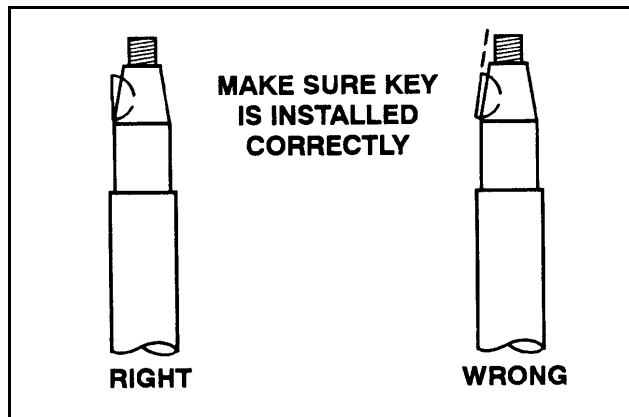

Figure 58

3297-020

**THIS PAGE INTENTIONALLY LEFT BLANK**

## Operation

The rewind starter operates through a retainer/friction disc that causes two engagement dogs to extend from the center of the rewind starter and engage the inside of the starter hub on the flywheel. The engagement dogs move into contact with the starter hub when the rewind rope is pulled. When the engine starts, the starter cup accelerates. As the speed of the starter cup exceeds the speed of the recoil starter, the ramps on the inside of the starter cup will contact the back side of the starter dogs and push them inward. Also, if the starter rope is relaxed, the spring will cause the dogs to retract.

## Removal and Disassembly

Note: The rewind starter assembly housing is attached to the shroud with rivets.

1. Remove any necessary shrouding to reveal fuel tank. Remove the fuel tank.
2. Remove the two hex head screws (A) that attach the shroud to the base. Also, there are 2 studs (B) on the cylinder head that are used to attach the shroud. Remove the nuts and washers from the studs. The shroud can then be rotated towards the cylinder head until there is enough clearance to slide the shroud off the studs. (See Figure 60.)

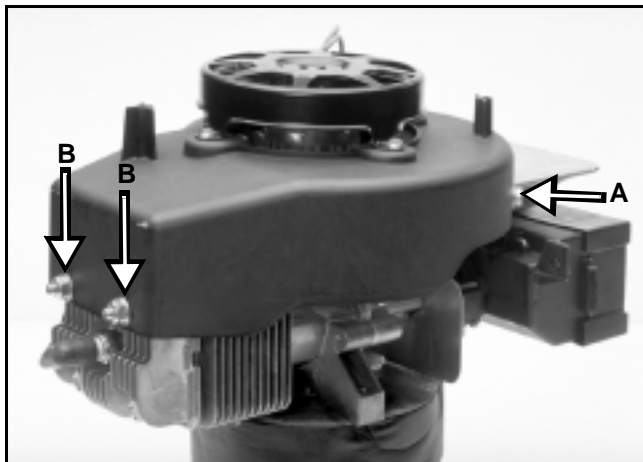

Figure 60

720-002

3. Drill out the rivets connecting the recoil and the shroud. Note the orientation of the starter.

4. This recoil starter is a pressed together assembly. Due to the low cost of the assembly, we do not stock individual parts. Should the recoil fail due to something other than a starter rope, we recommend replacing the assembly. The replacement recoil will be connected to the shroud with nuts and bolts.

## Reassembly

Both the DuraForce and R tek engines use starter ropes about 7 feet long.

1. To wind the rope and pretension the spring, turn the pulley counterclockwise — six (6) turns for the R tek and 5 turns for the DuraForce. Insert the rope through the guide, then the reel. A pair of small needle nose pliers will be helpful. (See Figure 61.)



Figure 61

0893-010

# REWIND STARTER

---

2. Tie a single knot in the end of the rope; then singe the end with a lighter to prevent the knotted end of the rope from fraying (see Figure 62). Tie a simple knot in the rope to prevent too much from retracting until the starter handle is installed.



**Figure 62**

lbv0043d.bmp

3. Reassemble the starter and shroud with the four screws and nuts. Remember the orientation of the rope outlet.
4. The shroud must be assembled by slipping the shroud over the two studs on the cylinder head then rotating the shroud down until the holes on the engine block and shroud align. Install the nuts on the studs and two screws on the side opposite the head. Note: Do not overtighten. (See Figure 63.)

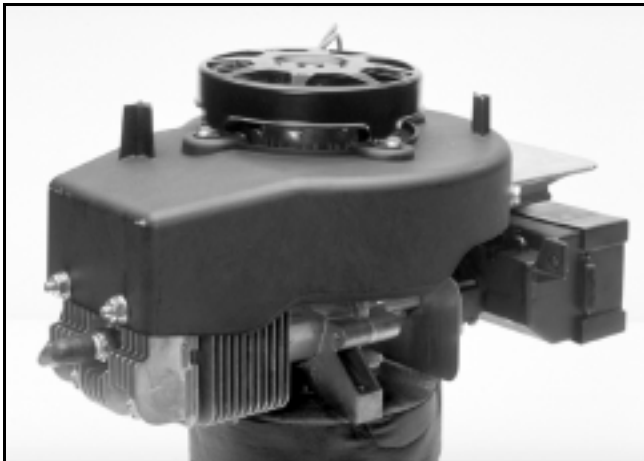

**Figure 63**

0720-002

## General Information

In this section, we will cover both versions of the E series engine. The DuraForce is a reed valve engine, and the R tek is piston ported. The design difference affects the path which the incoming fuel/air charge takes to get to the firing chamber.

Two-cycle engines have special advantages which make their use more practical in certain applications. Two-cycle engines are lightweight with an excellent power-to-weight ratio and can be operated in any position, limited only by the carburetor and fuel supply system. They are also notably easy to maintain and service because of their uncomplicated design.

## Theory of Operation

### Reed Valve Engine

The illustration below (see Figure 64) shows what happens inside the engine during one full crankshaft revolution. Fuel intake, fuel ignition, and the exhaust of burned gases all take place during a single 360-degree rotation of the crankshaft.

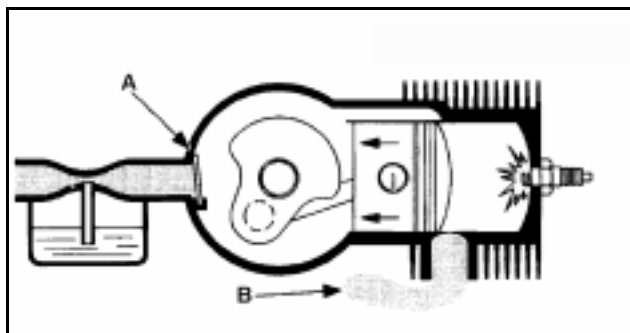
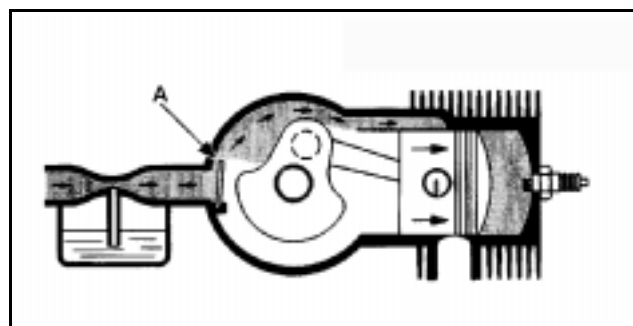

**Figure 64**

3297-022-2

A. Reed Valve Closed    B. Exhaust Gases

Beginning at a point where the top of the piston is just below the exhaust port, the piston moves forward toward the crankcase. As the transfer port is uncovered, the fuel/air mixture stored in the pressurized crankcase is forced into the combustion chamber. (See Figure 65.)



**Figure 65**

3297-021-2

A. Reed Valve Open

The crankshaft continues its rotation, and the piston begins its travel toward the spark plug. As it moves, the piston seals off the transfer port first, then the exhaust port. When both ports are sealed, the remaining travel compresses the air/fuel mixture to prepare it for ignition. The travel of piston towards the spark plug is called the compression stroke. (See Figure 65.)

The movement of the piston towards the spark plug also has an important effect in the crankcase. Once the transfer port is sealed, a vacuum is created in the crankcase. This action pulls the reed valve open and draws in a fresh charge of fuel/air mixture.

Just before the piston reaches top dead center (TDC), the spark plug fires. When the engine is functioning properly, the fuel/air mixture ignites, causing a burn that occurs evenly through the power stroke. The piston changes direction and begins its travel towards the crankcase.

**NOTE:** If the compression ratio is too high, the fuel/air mixture actually explodes before it is ignited by the spark plug. This can be heard and is identified as detonation (also called "knock").

When the piston opens the exhaust port, high-pressure exhaust gases exit the exhaust port. Further movement of the piston towards the crankcase uncovers the transfer port which allows a fresh charge of air/fuel mixture to enter the combustion chamber. As the exhaust gases continue to exit the exhaust port, the engine is readied for another cycle.

# ENGINE

## Piston Ported Engine

In a piston ported engine, there are no reed valves. The fuel/air mixture enters the crankcase through a third port that is opened and closed by the piston. (See Figure 66.) All other functions are the same as a reed valve engine.

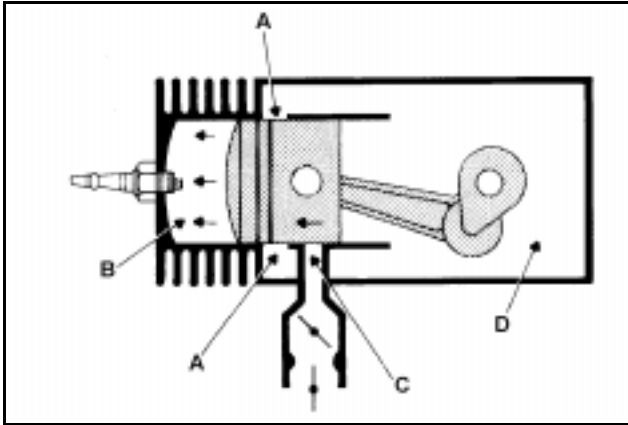

**Figure 66** 3297-001-2

- A. Intake Ports Closed
- B. Compression
- C. Third Port Closed
- D. Partial Vacuum

When the piston opens the exhaust port, high-pressure exhaust gases exit the exhaust port. (See Figure 68.) Further movement of the piston towards the crankcase uncovers the transfer port, which allows a fresh charge of oil/fuel mixture to enter the combustion chamber. As the exhaust gases continue to exit the exhaust port, the engine is readied for another cycle. (See Figure 69.)

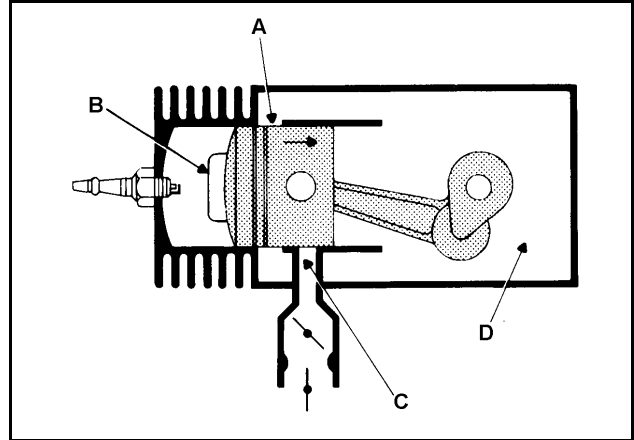
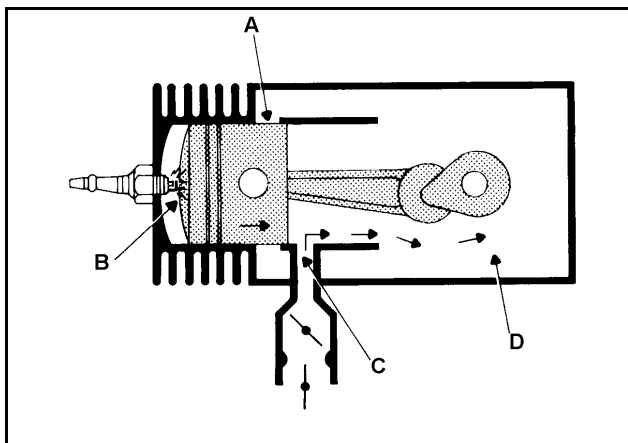

**Figure 68** 3297-003

- A. Intake Ports Closed
- B. Exhaust Port Opening
- C. Third Port Open
- D. Pressure Building Up

## Both Piston Ported and Reed Valve Engines

At about 28 degrees before top dead center (BTDC), the spark plug fires. When the engine is functioning properly, the air/fuel mixture ignites, causing a burn that occurs evenly through the power stroke. (If the compression ratio is too high, the air/fuel mixture actually explodes, which can be heard and is identified as detonation.) The burn continues as the piston changes direction and begins its travel towards the crankcase. (See Figure 67.)



**Figure 67** 3297-002

- A. Intake Ports Closed
- B. Ignition
- C. Third Port Open
- D. Partial Vacuum

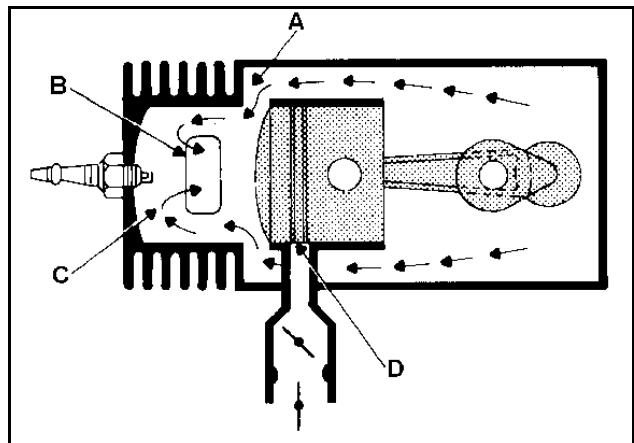

**Figure 69** 3297-004

- A. Intake Ports Open
- B. Exhaust Port Open
- C. Fresh Fuel Change
- D. Third Port Closed

The 2-cycle engine is always well lubricated as long as the correct oil/fuel mixture is maintained in the fuel tank. Oil suspended in the fuel vapor adheres to all moving parts, keeping them continually coated, regardless of operating angle.

## Service Tips

### 1. Cylinder/Crankcase Halves

The two halves are a matched pair and cannot be exchanged between engines. Follow all cleaning and assembly procedures in this subsection. Be sure to use Loctite 515 on the mating surfaces. Torque the six screws that secure the two halves. See specifications.

### 2. Oil Seal

Visually inspect for leaky or damaged oil seals (two locations). See the Seal Service section for the procedure.

### 3. Engine Base/Muffler Baffle (Lawn mower only)

This item should be checked and/or cleaned every 100 hours (maximum) to keep carbon from clogging exhaust system (power loss) and from entering engine (causing piston scoring). See Cleaning Exhaust, see page 15.

### 4. Exhaust Ports

The exhaust ports should be inspected and cleaned as necessary (see page 15.)

### 5. Carburetor Gaskets

Carburetor gaskets on either side of the carburetor shield may be leaking or damaged causing air leaks into the engine (may cause power fluctuations). Ensure that air cleaner/carburetor mounting screws are properly tightened (see Specifications).

## Disassembly

Removal of the shroud, recoil starter, flywheel, ignition coil, and carburetor are covered in other parts of this book and will not be repeated here.

1. Remove the six crankcase cap screws, and separate the halves using a screwdriver. (See Figure 70.) Be careful not to damage the sealing surfaces.

2. Remove the entire crankshaft assembly, and discard the oil seals.

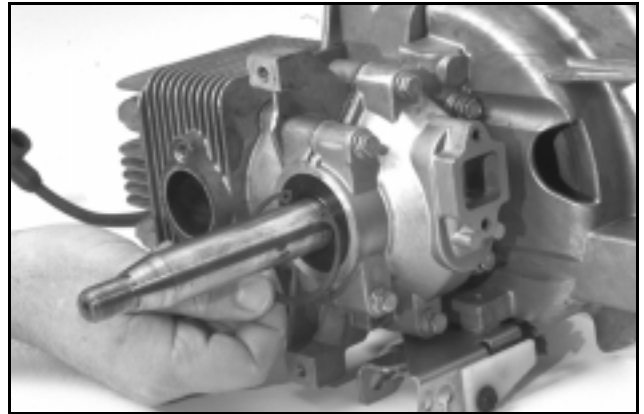

Figure 70

1657-012

3. Carefully remove the HSH (hex, socket head) cap screws (A) (see Figure 71) to remove the connecting rod cap and the split bearing liner. The needle roller bearings are under the split bearing liner. (See Figure 72.)

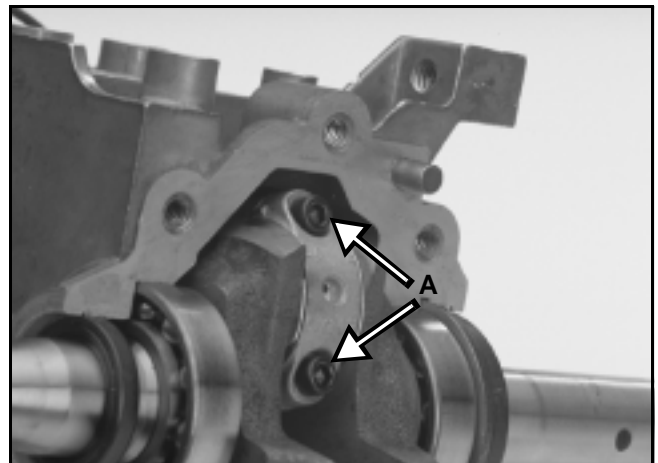

Figure 71

0720-013



# ENGINE

- Remove the piston and rod assembly. Separate the assembly if necessary, using a snap ring pliers on the retaining ring (16). Use wrist pin knock out tool (P/N 602884) to punch out wrist pin (17). (See Figure 72.)



Figure 72

0893-24b

- Check all parts for wear or damage and replace if questionable.
- Clean crankcase surfaces with Gel Seal and Gasket Remover. (See Figure 74.)

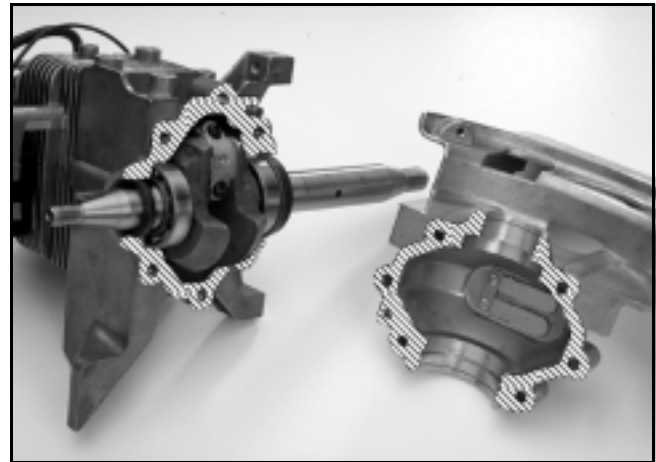

Figure 74

0720-014h

- Remove the two bolts and two nuts retaining the cylinder head to the block. Remove the head and discard the head gasket. (See Figure 73.)

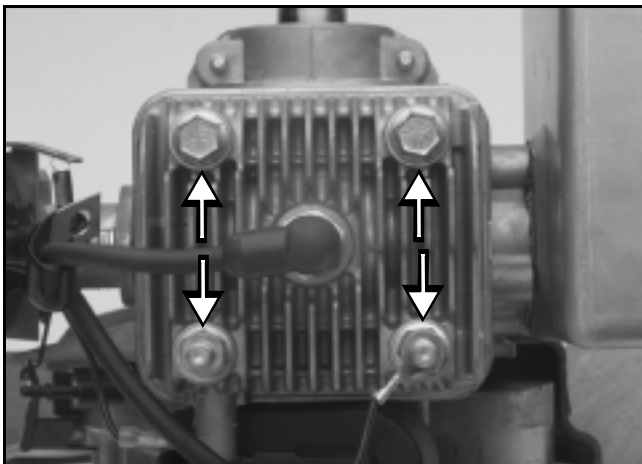

Figure 73

720-008

- Use a feeler gauge to check that the ring end gap is to specifications.

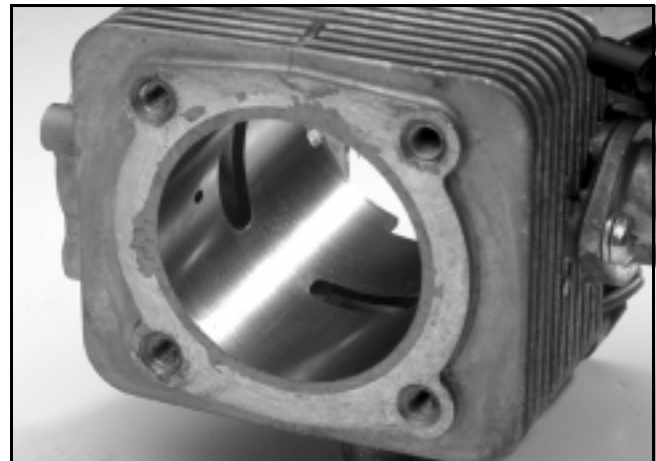

Figure 75

0893-014

- Inspect the piston and cylinder (see Figure 75). A good piston will show most of the machining marks on the surface. Some things that indicate piston and cylinder damage are:

## Inspection and Repair

- Check bearings for wear and freedom of movement; replace the bearings if questionable.
- Check rings for sticking. Remove and check rings for wear or damage; replace rings if questionable. Clean any carbon buildup from the ring grooves before installing new rings. It is best to use a piece of hardwood to scrape carbon loose. Should you use a metal tool, you might damage the piston.

- A. Vertical scratches that appear all the way around the piston sometimes is combined with discoloration (see Figure 76). Scratches all the way around the piston indicate high hours or dirt ingestion. If the scratches are in limited areas, look more closely to see if they are in line with the ports. On a NEW engine, if the ports are not properly deburred, piston damage can result. This can appear ONLY on engines with very few hours on them. The damage is immediate. If the engine has more than a couple of hours use, inspect the carburetor, reed area, and crankcase for any sign of dirt. Much of the dirt that an engine ingests does its damage and goes out the exhaust. Any dirt found in these areas indicate that the engine has ingested a great deal more. If an engine has ingested dirt, the best solution is a short block replacement as the bearings have been exposed to that dirt also.



**Figure 76** 0893-027

- B. Discoloration of a piston is often caused by improper lubrication. Without the necessary lubrication, friction increases and overheats the piston. Often in an engine that failed due to improper lubrication, the piston is discolored, the rings may be stuck, yet the lower rod and crankshaft bearings might appear usable. As the piston is the source of the friction and heat, the bearings, further from the heat source, may not appear damaged. However, we would not recommend re-using bearings in an engine that failed due to improper lubrication.

- C. Cylinder damage is usually less than the damage to the piston. As the cylinder liner is made of harder material, it can stand more abrasion. However, it is generally best to replace the short block if severe piston damage is present, as it is the most cost-effective repair.

## **Reed Valve Service (DuraForce Engines Only)**

The reed assemblies (see Figure 77) permit fuel mixtures to enter the crankcase on compression strokes and to trap fuel mixtures in the crankcase on power strokes.

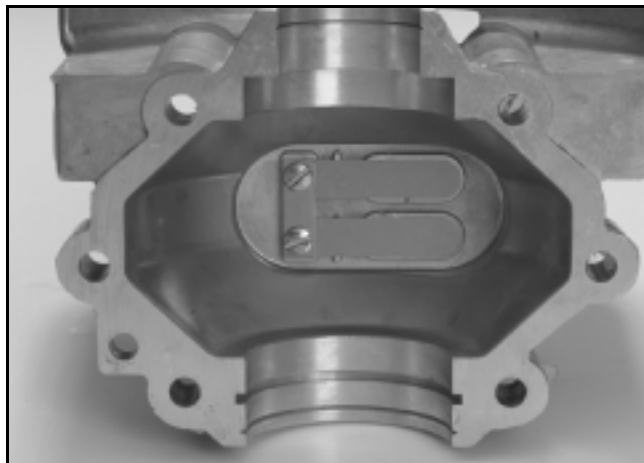

**Figure 77** 0720-018

1. Check clearance between tip of reed and plate; replace reeds if clearance is more than .020" (.5 mm).

**CAUTION:** Do not use compressed air to clean reeds.

2. Clean reeds carefully, by hand, using carburetor solvent.

# ENGINE

3. When replacing reeds, install smooth edge down centered over openings in crankcase (see Figure 78), and use Loctite 271 on threads of screws. Torque per specifications.

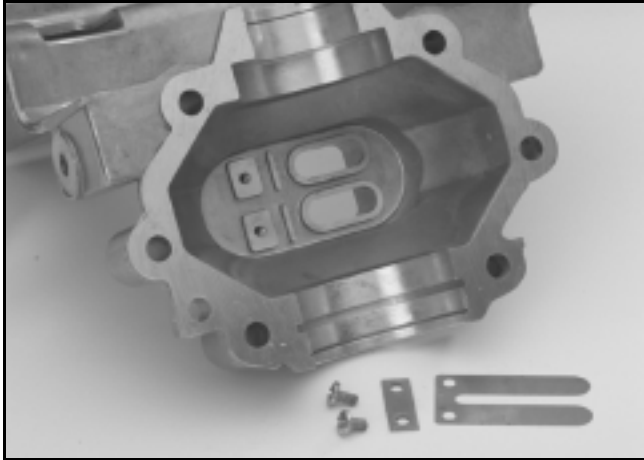

**Figure 78**

0720-020

## Reassembly

Assemble the piston and connecting rod. Note the piston has the letters EX and an arrow stamped into the top. The arrow should point towards the exhaust port. The connecting rod can be assembled to the piston two ways. As the rod is symmetrical, either way is acceptable. We will phase in match marks on the rod and rod caps. Some of the very early engines may not have these marks. Use a permanent marker if match marks are not visible.

1. Secure wrist pin using snap ring. Make sure square edge of snap ring faces out and ring opening faces up (toward top of piston). (See Figure 79.)

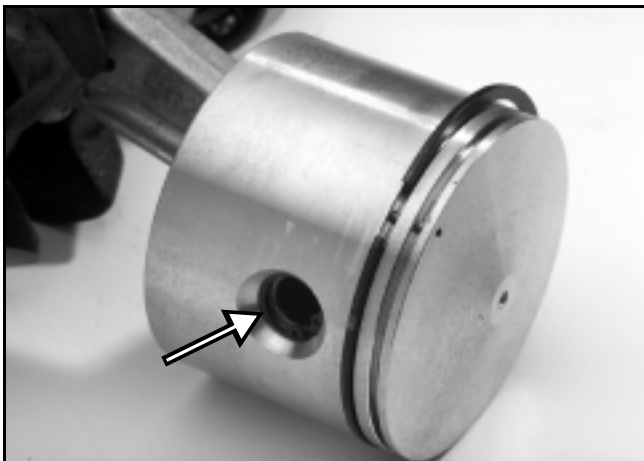

**Figure 79**

0893-028

2. Several piston and ring combinations have been used. Pistons have been plated and unplated. Pistons have used two keystone rings and others used one semi-keystone and one standard ring. The pistons made for one type of ring will not accept the other type. However, any piston and ring assembly can be used in any cylinder.

Install keystone piston ring in top groove with bevel facing up. The square bottom ring can be installed either way. Note that there are pins in the ring grooves. The open ends of the rings must line up with the pins.

3. Assemble ball bearings to crankshaft and install crankshaft.
4. Note: One side of the paper is sticky; remove paper carefully while installing needle bearings. There should be 32 needle bearings on the lower connecting rod. When reinstalling original needle bearings, use a little #2 bearing grease to stick the needles to the rod.
5. Install rod cap (A). Ensure that mating marks are aligned. Clean old screws (B) thoroughly and apply Loctite 271. (See Figure 80.) Torque to specifications.

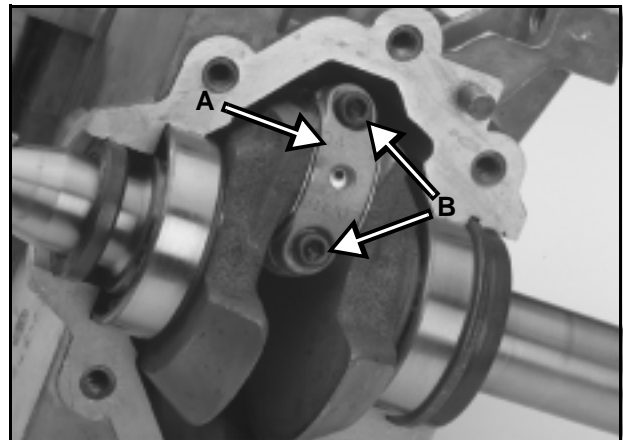

**Figure 80**

0893-023

6. Oil parts. Use ring compressor to install piston with EX mark and arrow pointing towards the exhaust port. Install seals before fully seating the crankshaft. Install new oil seals. Clean seal bore with alcohol before installing seals. Oil in the bore may cause the seal to blow out when the engine is hot.

Note: Ring Compressor P/N TOR 4089 (order from OTC, see page 5 for address and phone).

- Apply Loctite 515 gasket maker very thinly to the crankcase cover sealing surface (A), being careful not to get sealant in bearings. (See Figure 81.)

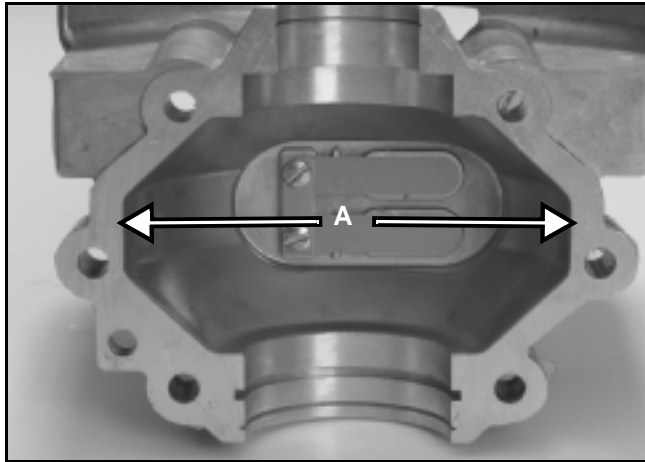

**Figure 81**

0720-018

- Carefully align the two crankcase halves using the alignment pin (A) and its matching hole. Press the two halves together. (See Figure 82.)

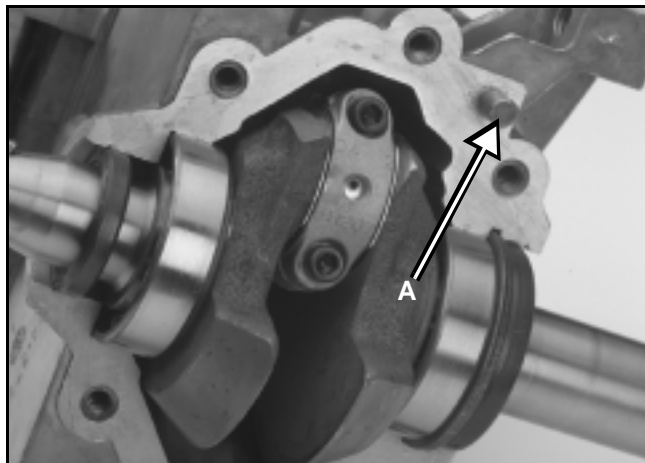

**Figure 82**

0720-015

- Tighten the screws to specifications, tightening only 20 in. lbs. (2.26 Nm) increments at a time while tightening modified (X) pattern. (See Figure 83.)

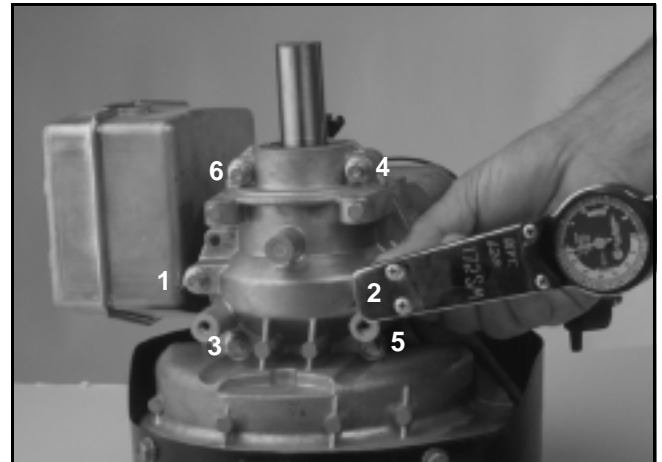

**Figure 83**

0891-005

## ***Reinstalling External Components***

- Reattach the flywheel brake system.
- Clean the crankshaft and flywheel hub with alcohol and install flywheel.
- Install carburetor and governor assembly.
- Install starter and shroud assembly and starter handle.
- Reconnect fuel lines and electrical system leads.
- Install CD pack and set air gap. (See Ignition System on page 31.)
- Test run engine.

# ENGINE

## Crankshaft Seal Replacement

The crankshaft seals on both the R tek and DuraForce engines are located right on top of a groove in the bore (Figure 85). The rubber on the outer diameter of the seal grips the groove and provides a seal as well as holding the seal in place. Only the PTO seal on the DuraForce engine has a snap ring installed after the seal to help hold it in place (Figure 84). As both the R tek seals and the DuraForce flywheel seal must set on top of the groove, we do not recommend driving a new seal in place. Driving the seal over the groove would damage the rubber on the outside of the seal.

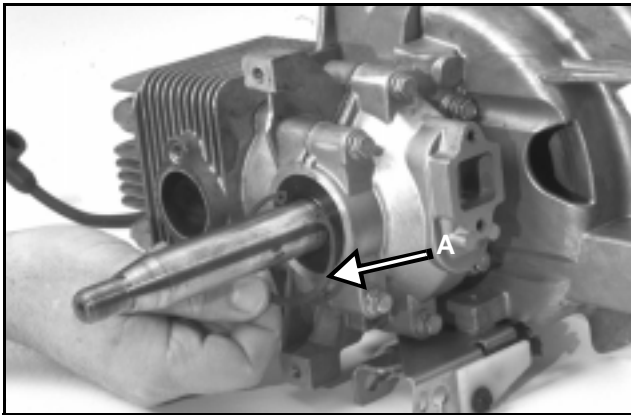

Figure 84

1657-012

Separate the crankcase from the cylinder to replace the seals. Slide the seals off the crankshaft and clean the case mating surfaces as previously indicated. Clean the block where the seal goes and the outside of the seal with alcohol to ensure they are oil free. If oil is in the bore or on the seal O.D. the lubrication may cause the seal to move when hot.

Use some type of seal protector to prevent damage to the seal lip and slide the seal down the crankshaft. The seal must rest directly on top of the groove in the block. Seal the crankcase halves as previously indicated. Ensure the seal does not move while assembling the crankcase.

The snap ring on the DuraForce PTO end should be installed after the six cap screws are torqued down. Both R tek seals and DuraForce flywheel end seal

The snap ring on the DuraForce PRO end should be installed after the six cap screws are torqued down. Both R tek seals and the DuraForce flywheel end seal location can be checked after assembly. These seals should be recessed between .040" and .060" (1.016 - 1.524mm). Check the depth in about 3 places to ensure the seal is at the proper depth and square in the bore.

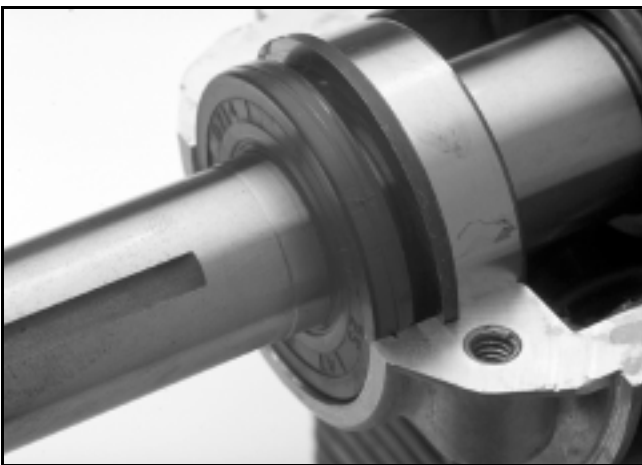

Figure 85

0893-016

## PIVOTING ZONE START BRAKE (DuraForce Engines Only)

### Introduction

In 1982, the federal government mandated that all consumer walk behind mowers with a cut of 25" (63.5 cm) or less be equipped with safety devices. There are two primary criteria which these devices must meet:

1. A two-step operation must be performed in order to start the blade rotating.
2. The blade must come to a stop within three seconds of the operator leaving the operator's position.

One of the ways the Lawn-Boy Corporation met these requirements was with the "zone start system." This system utilizes a kill switch and a brake, which stops the engine when the operator releases the blade control bail (A). (See Figure 86.) The two-step blade engagement criteria is met by requiring the operator to pull the bail to the handle first, then pull the recoil rope from the operator's position.

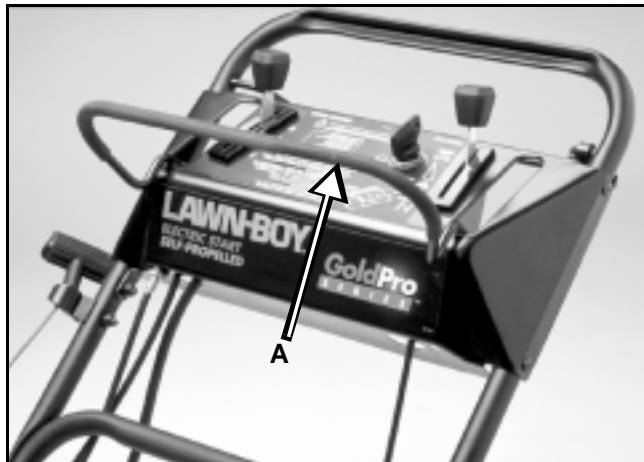

Figure 86

0893-048

### Operation

The pivoting style zone brake system has two main functions. The first function of the system is to stop the production of spark and the second is to stop the engine and the blade.

Stopping spark production is controlled by a switch.

The switch is closed when the blade control bail is in the "at rest" (vertical) position. (See Figure 86.) Lowering the bail to the main mower handle opens the switch.

Switch leads are connected to the primary side of the coil and to ground (see Figure 87). When the switch is closed, the electronic ignition module is bypassed so that it cannot interrupt primary current flow. This action prevents the coil from producing the high voltage necessary to generate spark. When the switch is open, the ignition coil produces spark.

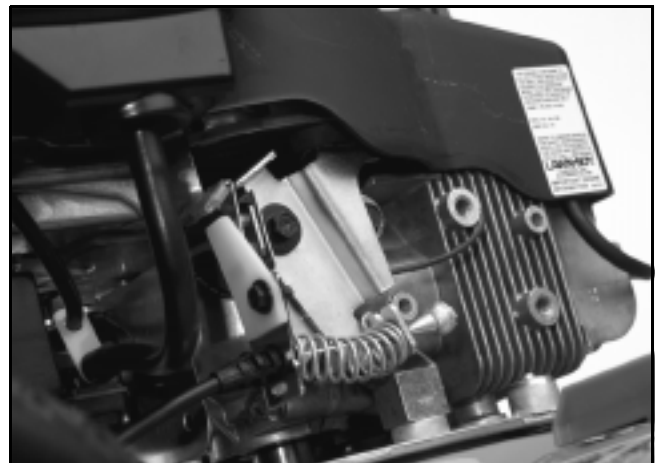

Figure 87

0893-043

Stopping the engine and blade is accomplished by means of a brake that is applied to the flywheel. The brake spring is in the "braked" position when the blade control is in the "at rest" or vertical position. When the blade control bail is lowered to the mower handle, the brake is retracted and allows the engine to run.

# PIVOTING ZONE START BRAKE

There are two versions of this brake. The function is the same, but they contact different parts of the flywheel. Figure 88 is a diagram of the system used on recoil start engines. The brake pad engages the bottom of the flywheel. Figure 89 is a photo of a slightly different system used on electric start engines. On electric start engines, the brake pad must contact the side of the flywheel to clear the teeth of the flywheel ring gear.

## Disassembly

Recoil

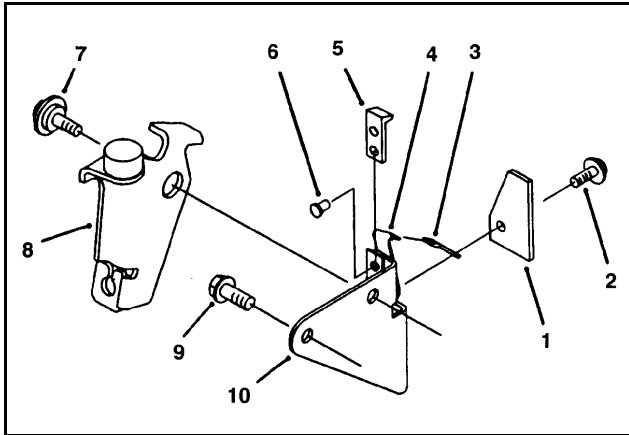

Figure 88

3297-023

- |                            |  |
|----------------------------|--|
| 1 - Ground strap stop      | 6 - Plastic rivet (self expanding) (2) |
| 2 - Self-tapping screw     | 7 - Shoulder screw (10 mm)             |
| 3 - Brake switch lead wire | 8 - Brake plate assembly               |
| 4 - Ground strap           | 9 - Screw                              |
| 5 - Insulation strap       | 10 - Brake mounting plate              |

Electric Start

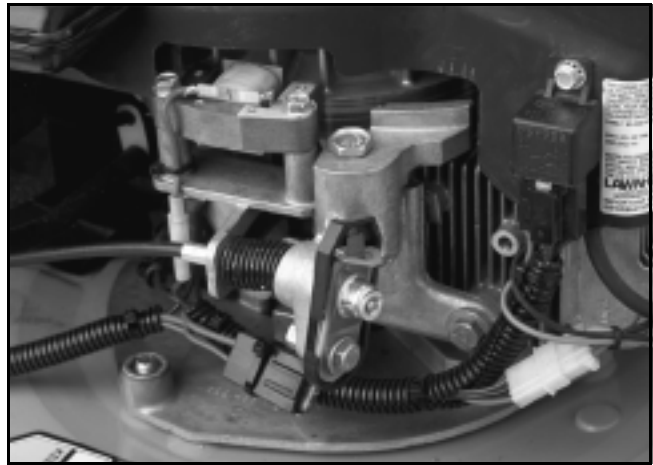

Figure 89

0893-040

Note: Numbers in parentheses in the following procedures refer to the previous illustration (see Figure 88).

1. If the engine and blade are taking more than 3 seconds to stop when the blade control bail is released, inspect the brake pad for excessive wear and replace if necessary. Note that the brake pad and the brake plate are replaceable only as an assembly.
2. To reduce the pressure of the spring between brake mounting plate (10) and brake plate (8), squeeze tabs of brake cable that hold it in place at the brake mounting plate. Push cable through the hole in brake mounting plate.
3. Slide cable out through horizontal slot in brake mounting plate. Also, slide the ball end of the cable up through the vertical slot in the brake plate.

Note: In step 4, some units may use a 3/8" head with 1/4" diameter screw (rather than a 10 mm).

4. Remove the 10 mm shoulder screw (7) to remove the brake plate and brake pad attached to it.
5. If the ground strap or any part of this assembly requires replacement, remove the second screw (9) to remove the brake mounting plate from the engine.

# PIVOTING ZONE START BRAKE

## Assembly

1. If the brake mounting plate was not removed from the engine, simply reconnect the grounding lead to the push-on terminal directly above the ground strap stop (4) and continue with the reassembly process.

Note: If the brake mounting plate was removed, tighten screw (9) to 60 - 70 in. lbs. (6.78 - 7.91 Nm).

2. Secure the replacement brake plate to the engine with shoulder screw (7). Tighten it to 90 in. lbs. (9.2 Nm). Ensure that the brake plate pivots freely.
3. Slide the cable into the narrow slot on the brake mounting plate, and then push the cable into the hole making sure the tabs lock into the bracket.
4. One end of the compression spring has a hook shape to it; that end hooks over an indentation in the brake plate. Squeeze the compression spring (A) and slip it over the cable between the brake mounting plate and brake plate. (See Figure 90).

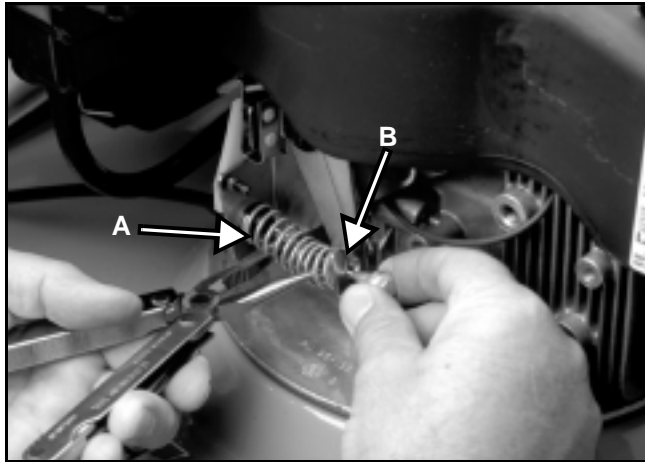

Figure 90

0893-051a

5. Insert the leaded ball end of the cable into the vertical slot (B) of the brake plate. (See Figure 90.)

6. Operate the blade control bail to verify that the brake mechanism stops within three (3) seconds. There is no adjustment needed after this assembly process is completed. (See Figure 91).

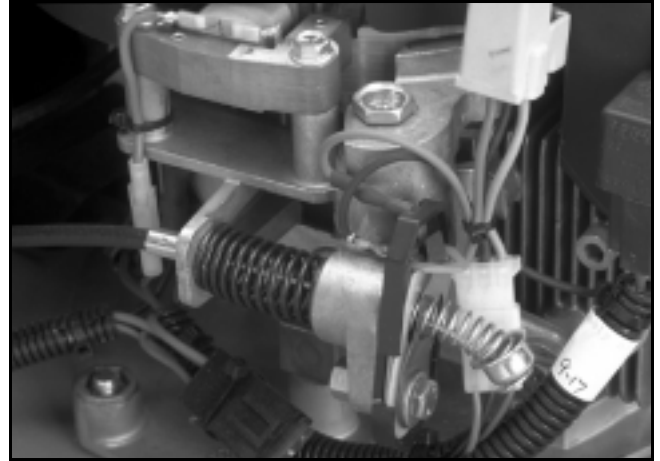

Figure 91

0891-1



**THIS PAGE INTENTIONALLY LEFT BLANK**

# ELECTRIC START SYSTEM (120 VOLT)

## Troubleshooting

### Starter Motor Fails to Turn

Possible Cause	Correction
Power not reaching product	Plug another appliance into extension cord to ensure cord is OK.
Starter switch malfunction	Check switch using a volt/ohmmeter set for resistance. Ensure that there is continuity when the switch is depressed.
Engine has seized	Verify that the engine turns over freely.
Starter motor has failed	If all the above conditions are checked and the starter still fails to turn, it must be repaired or replaced.

## Introduction

The electric start models of the R tek engine use a 120 volt starting system. When the starter is supplied with voltage, the helical shaft spins forcing the pinion gear to slide out on the shaft and engage the ring gear. (See Figure 92.)

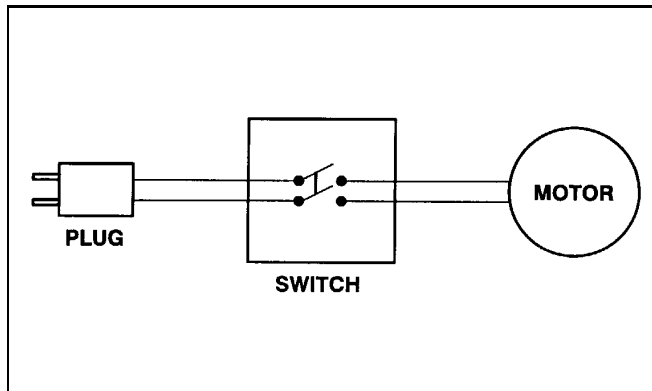

Figure 92

120V

## Starter Removal

1. Remove the upper housing. Remove the starter switch, the bolt holding the wire clip, and the two bolts which mount the starter to the engine. (See Figure 93.)

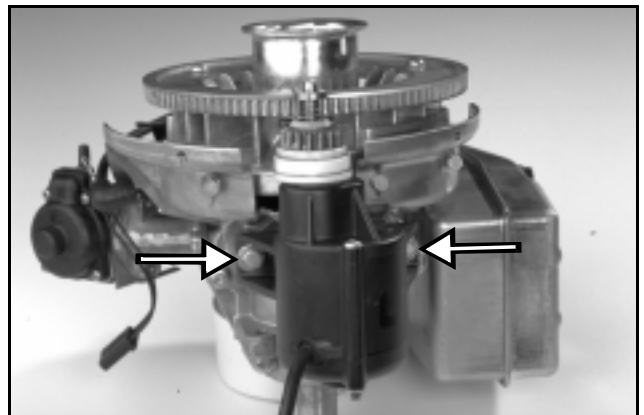

Figure 93

1657-017

# ELECTRIC START SYSTEM (120 VOLT)

---

## ***Starter Disassembly***

1. Remove the pinion retaining clip by applying constant pressure towards the end of the shaft on one end of the clip and working around the rest of the clip. Always replace clip with a new one.
2. Slide the stop washer, pinion spring, and pinion off the shaft.
3. Remove the two housing bolts and separate the ends from the body. Pay close attention as things come apart easily when disassembling.
4. The serviceable items are shown. (See Figure 94.)

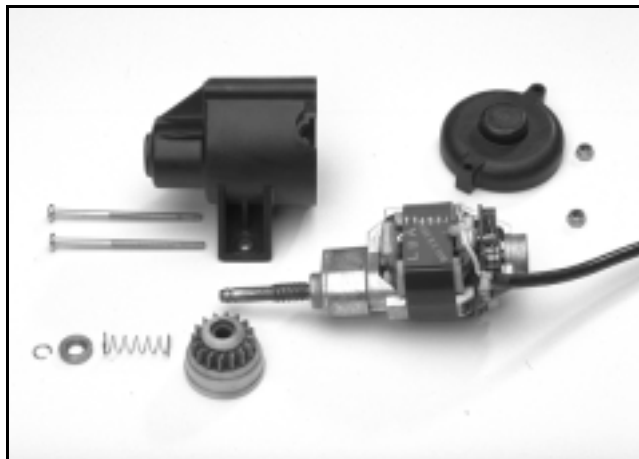

**Figure 94** 1657-022

5. The starter switch is also serviceable. (See Figure 95.) (Note: The wires can be removed by inserting a small diameter drill bit into the holes to release the jaws.)



**Figure 95** 1657-021

## ***Starter Assembly***

Assemble by reversing the disassembly process.

## ***Starter Installation***

Install by reversing the removal procedure.

# ELECTRIC START SYSTEM (12 VOLT)

## Troubleshooting

### Starter Motor Fail to Turn

Possible Cause	Correction
Starter motor has failed	Check by disconnecting the spark plug wire and starter wiring connector. Apply 12 volts directly to the starter motor. (Note: Due to the connector arrangement, it is possible that the starter motor will turn backwards during this test. This does not harm the motor.)
Battery has low charge or is disconnected	Check battery for full charge and ensure it is connected.
Engine has seized	Verify that the engine turns over easily.
Starter switch malfunction	Use a volt/ohmmeter to insure there is continuity in the start position.
Bad ground	Check to ensure the ground is secure and not corroded.
Bad wires between battery and starter	Use a volt/ohmmeter to ensure that continuity exists

### Introduction

The electric start models of the DuraForce engine utilize a 12 volt starting system consisting of a:

- starter motor
- battery
- key switch
- alternator
- regulator (cup assembly)
- starter relay
- fuse

### Starter Removal

1. Unplug the wiring connector at the starter. Remove the three screws that secure the upper fuel tank/shroud assembly, and move it off to one side. While it is not necessary to disconnect the fuel line, the fuel tank should be nearly empty while working on the starting system.
2. Remove the two nuts and two bolts that secure the inner shroud/recoil housing, and move it off to the side. Again, it is not necessary to remove the assembly from the unit.

3. Loosen the Allen head bolt used to secure the starter pin with a 1/4" Allen wrench. (See Figure 96.) It may be necessary to remove the carburetor bolts and lower the carburetor to gain access the needed clearance for the Allen wrench.

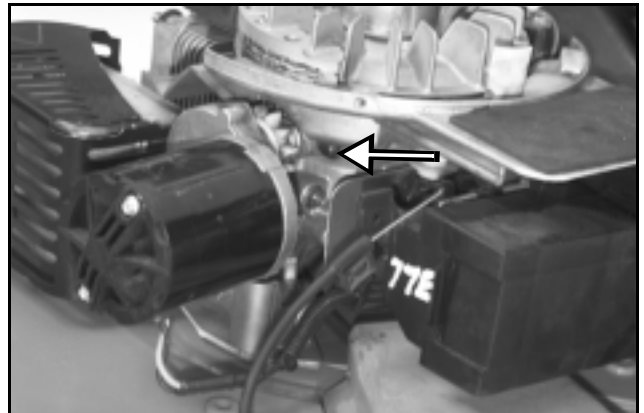

Figure 96

1657-005

# ELECTRIC START SYSTEM (12 VOLT)

4. Remove the bolt that secures the lower bracket to the chassis. Remove the starter. While removing, be careful not to move the starter side to side as you may bend the pinion shaft. (See Figure 97.)

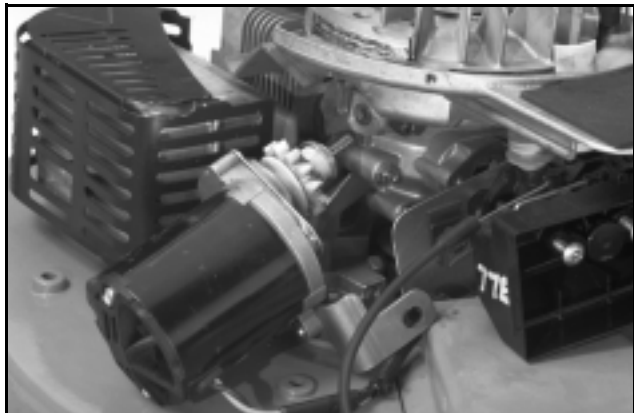

Figure 97

1657-004.tif

2. Remove the two screws and drag-spring stud (A) that secure the gear cover plate to the motor housing. (See Figure 99.) Remove the cover plate. Note that the plate has "OUT" stamped on the top. During installation "OUT" must face the pinion/clutch assembly.

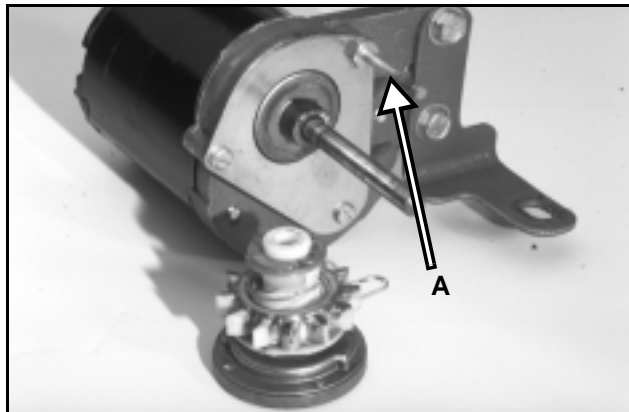

Figure 99

1657-016.tif

## Starter Testing

1. Connect the red lead of an ohmmeter to the red wire of the starter connector and the black lead of the ohmmeter to the blue wire. Slowly rotate the armature through 360 degrees. If rotated rapidly, the starter acts like a generator and readings will be incorrect.
2. Measure resistance. Reading should be less than 10 ohms. If high resistance or open circuit (infinite resistance) is shown, replace the starter motor.

## Starter Disassembly

1. Slide the pinion/clutch assembly (A) off the pinion shaft. Remove the retaining ring from the pinion/clutch assembly and disassemble completely. Inspect all parts for wear or damage and replace as needed. (See Figure 98.)

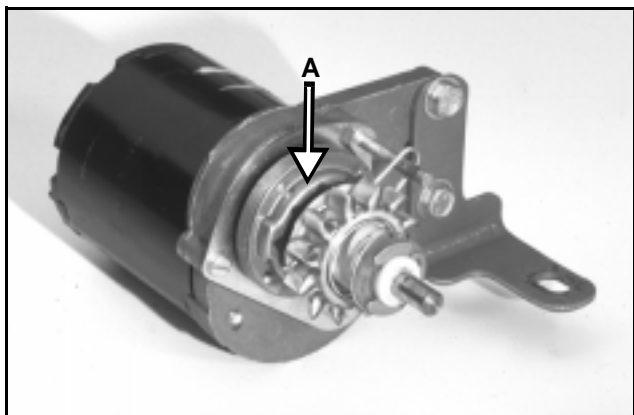

Figure 98

1657-020

3. Remove the pinion gear, driven gear and thrust washer. Clean all parts thoroughly and inspect for damage or wear. (See Figure 100.)

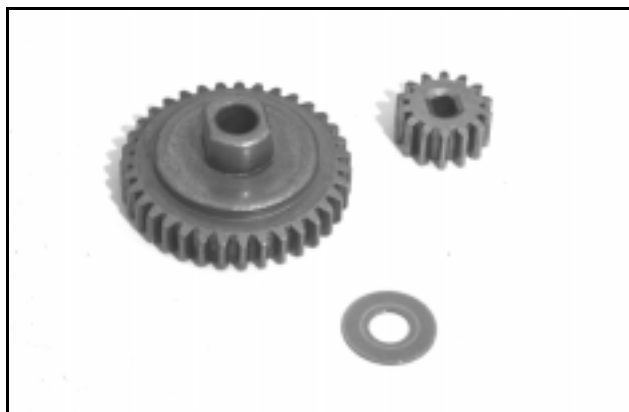

Figure 100

1657-019

# ELECTRIC START SYSTEM (12 VOLT)

## Starter Assembly

1. Apply a light coat of Lawn-Boy "AX" grease to the pinion gear, thrust washer, and driven gear prior to installation.
2. Place the pinion gear on small driveshaft in motor housing with either side facing up. (See Figure 101.)
3. Place the thrust washer then the driven gear on the pin. Make sure the raised side of the driven gear is facing the cover plate.



Figure 101

1657-013.tif

4. Install the cover plate with the word "OUT" facing the pinion/clutch assembly and secure with two screws and drag spring stud. Make sure you replace the drag spring stud in its original position. Torque screws and stud to 20 in. lbs.

5. Reassemble pinion/clutch assembly. Apply a small amount of Lawn-Boy "AX" grease to the pin. Slide the assembly on to the pin with the drag spring (A) over the stud. (See Figure 102.)

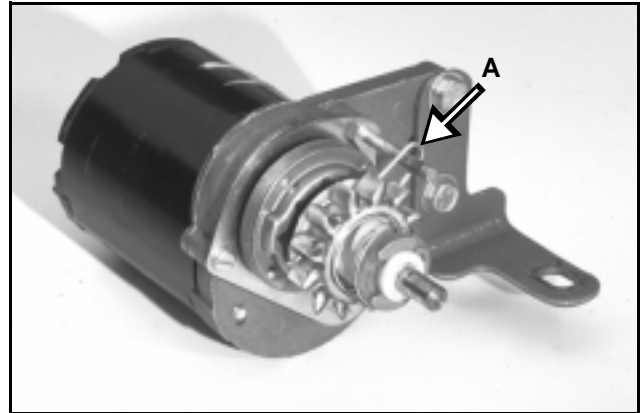

Figure 102

1657.020

## Starter Installation

1. Install the starter leaving the bolts loose.
2. Using a feeler gauge, gap the end of the pinion/clutch assembly away from the engine .019" to .021" (.48 mm to .53 mm). While keeping this air gap, tighten the Allen head bolt first, then the lower mounting bolt.
3. Plug the wiring connector in and install the shrouds and fuel tank.

# ELECTRIC START SYSTEM (12 VOLT)

## Alternator Introduction

Electric start DuraForce engines are equipped with an alternator to keep the battery "topped off". The charge rate of this alternator is 500 milliamps. Due to the low

charge rate, it is important to use the 120 volt charger to fully charge the battery before initial use and at the start of each season. Frequent starts or hard starting may require using the 120 volt charger to recharge the battery. (See Figure 103.)

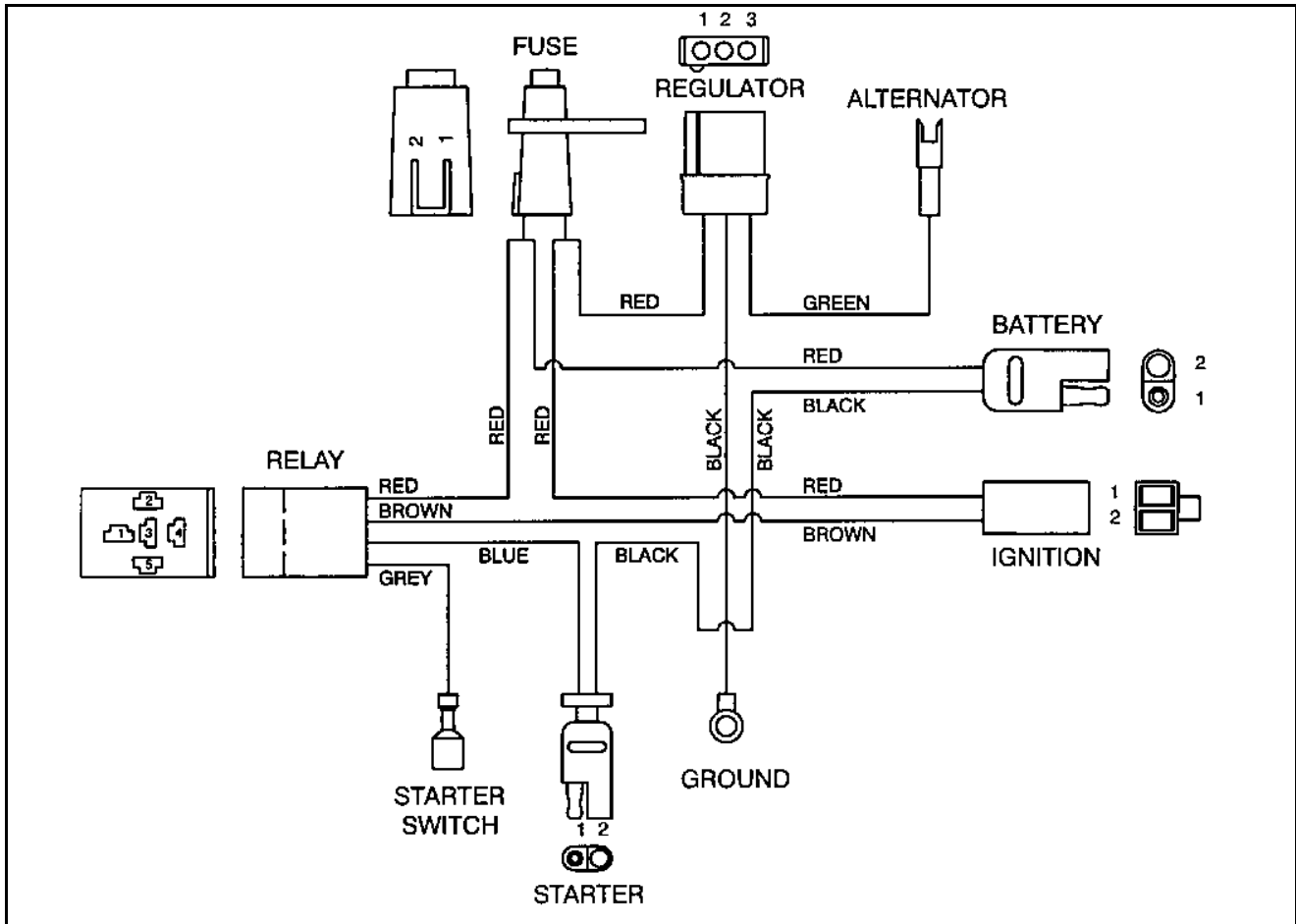

Figure 103

12v.tif

Note: Fuse - 5 amp, 2 blade automotive.

# ELECTRIC START SYSTEM (12 VOLT)

## Alternator Output Testing

1. To check output of the alternator accurately, it is necessary to run the engine at operating speed,  $2900 \pm 300$  RPM. Readjust the governor if necessary. Refer to page 26 (Presetting the Governor (DuraForce Engines Only)).
  2. With the engine running, unplug the battery connector and reconnect the plug so that only the black wires are connected. Using a multimeter, set to read 500 milliamps. Connect the red lead to the red wire going to the battery and the black lead to the red wire going to the mower.
- CAUTION:** Keep hands and feet away from the blade.
3. Measure alternator output. The reading should be from 190-450 M.A. (Milliampere) at  $2900 \pm 300$  RPM. If output is not within specification, check the alternator air gap.

## Alternator Air Gap Adjustment

1. Rotate the flywheel until the magnets are directly adjacent to the alternator. There should be a .010" (.25 mm) air gap.
2. If gap is incorrect, loosen the alternator mounting bolts slightly allowing the flywheel magnets to pull alternator against the gauge. Tighten the bolts to 75 in. lbs., and recheck the air gap. (See Figure 104.)

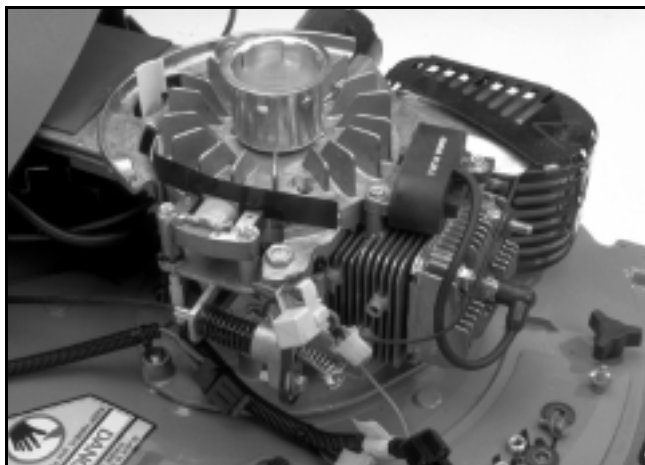

Figure 104

6.tif

## Alternator Resistance Check

1. Disconnect the electronic cup assembly from the wiring harness. Connect one ohmmeter (RX-1 scale) lead to the green wire of the wiring harness and the other to the engine block. (See Figure 105.)
2. Measure resistance. The resistance should be from 2.7 to 3.3 ohms. If specification is not met, check resistance at alternator connection. If specification is met at the alternator, look at the harness for breakage. If specification is not met at alternator connection, replace the alternator.

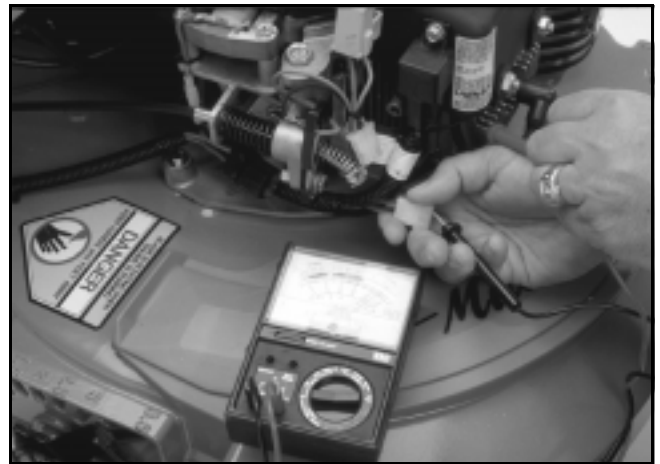

Figure 105

0891-004

## Cup Assembly Test

1. The cup assembly consists of a capacitor and diode. Its function is to convert alternating current to direct current and increase the voltage.
2. Disconnect the electronic cup assembly from the wiring harness. Connect one ohmmeter (RX-1 scale) lead to the green wire of the cup side of the connector and the other lead to the red wire of the connector.



# ELECTRIC START SYSTEM (12 VOLT)

---

3. Measure resistance. Reverse leads and measure resistance again. The specification is to have different resistance between the two measurements — high one way and low the opposite way. If specification is not met, replace the cup assembly. (See Figure 106.)



**Figure 106**

0891-003