



Form No. 3420-845 Rev A

**Count on it.**

**Operator's Manual**

**Groundsmaster® 4100 or 4110  
Rotary Mower**

Model No. 30608—Serial No. 401420001 and Up

Model No. 30644—Serial No. 401420001 and Up



This product complies with all relevant European directives; for details please see the separate product specific Declaration of Conformity (DOC) sheet.

**⚠ WARNING**

**CALIFORNIA  
Proposition 65 Warning**

**This product contains a chemical or chemicals known to the State of California to cause cancer, birth defects, or reproductive harm.**

**Diesel engine exhaust and some of its constituents are known to the State of California to cause cancer, birth defects, and other reproductive harm.**

It is a violation of California Public Resource Code Section 4442 or 4443 to use or operate the engine on any forest-covered, brush-covered, or grass-covered land unless the engine is equipped with a spark arrester, as defined in Section 4442, maintained in effective working order or the engine is constructed, equipped, and maintained for the prevention of fire.

The enclosed engine owner's manual is supplied for information regarding the US Environmental Protection Agency (EPA) and the California Emission Control Regulation of emission systems, maintenance, and warranty. Replacements may be ordered through the engine manufacturer.

# Introduction

This machine is a multi-purpose machine intended to be used by professional, hired operators in commercial applications. It is designed primarily for mowing grass on well-maintained lawns in parks, golf courses, sports fields, and on commercial grounds.

**Important:** To maximize the safety, performance, and proper operation of this machine, carefully read and fully understand the contents of this *Operator's Manual*. Failing to follow these operating instructions or to receive proper training may result in injury. For more information on safe operating practices, including safety tips and training materials, go to [www.Toro.com](http://www.Toro.com).

Whenever you need service, genuine Toro parts, or additional information, contact an Authorized Service Dealer or Toro Customer Service and have the model and serial numbers of your product ready. **Figure 1** identifies the location of the model and serial numbers

on the product. Write the numbers in the space provided.

**Important:** With your mobile device, you can scan the QR code on the serial number decal (if equipped) to access warranty, parts, and other product information.

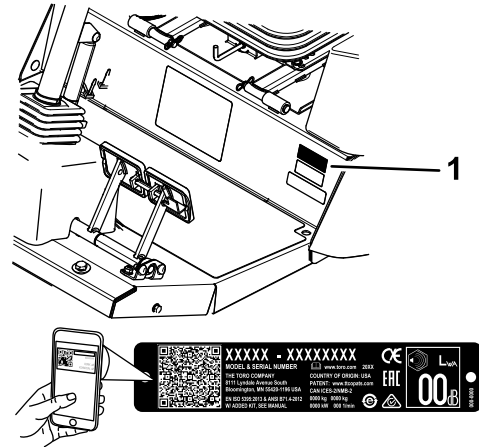

**Figure 1**

1. Model and serial number location

**Model No.** \_\_\_\_\_

**Serial No.** \_\_\_\_\_

This manual identifies potential hazards and has safety messages identified by the safety-alert symbol (**Figure 2**), which signals a hazard that may cause serious injury or death if you do not follow the recommended precautions.



**Figure 2**

1. Safety-alert symbol

This manual uses 2 words to highlight information. **Important** calls attention to special mechanical information and **Note** emphasizes general information worthy of special attention.

# Contents

Safety .....	4	Maintenance .....	56
General Safety .....	4	Recommended Maintenance Schedule(s) .....	56
Engine-Emission Certification .....	5	Daily Maintenance Checklist .....	57
Safety and Instructional Decals .....	5	Pre-Maintenance Procedures .....	59
Setup .....	15	Maintenance Safety .....	59
1 Greasing the Machine .....	15	Opening the Hood .....	59
2 Checking the Tire Pressure .....	15	Removing the Hood .....	60
3 Checking the Fluid Levels .....	16	Lubrication .....	61
Product Overview .....	16	Greasing the Bearings and Bushings .....	61
Controls .....	16	Engine Maintenance .....	63
Cab Controls .....	19	Engine Safety .....	63
Specifications .....	20	Servicing the Engine Oil .....	63
Attachments/Accessories .....	21	Changing the Engine Oil and Filter .....	64
Before Operation .....	22	Servicing the Air Cleaner .....	64
Before Operation Safety .....	22	Servicing the Diesel-Oxidation Catalyst (DOC) and the Soot Filter .....	66
Checking the Engine-Oil Level .....	22	Fuel System Maintenance .....	67
Checking the Cooling System .....	22	Servicing the Fuel System .....	67
Checking the Hydraulic System .....	22	Servicing the Water Separator .....	67
Draining the Water Separator .....	22	Electrical System Maintenance .....	68
Filling the Fuel Tank .....	22	Electrical System Safety .....	68
Checking the Tire Pressure .....	23	Servicing the Battery .....	68
Checking the Torque of the Wheel Lug Nuts .....	24	Servicing the Fuses .....	69
Adjusting the Mirrors .....	24	Drive System Maintenance .....	70
Aiming the Headlights .....	25	Adjusting the Traction-Pedal Angle .....	70
Adjusting the Rollover Protection System (ROPS) .....	25	Checking the Planetary-Gear-Drive Oil .....	70
Adjusting the Height of Cut .....	26	Changing the Planetary-Gear-Drive Oil .....	70
Adjusting the Skids .....	28	Checking the Rear-Axle Lubricant .....	71
Adjusting the Mower-Deck Rollers .....	28	Checking the Rear-Axle-Gearbox Lubricant .....	71
Adjusting the Blade .....	29	Changing the Rear-Axle Lubricant .....	72
Correcting a Mismatch Between the Mower Decks .....	29	Checking the Rear Wheel Toe-In .....	72
Checking the Safety-Interlock Switches .....	31	Changing the Front Tires .....	72
Using the InfoCenter Control .....	32	Cooling System Maintenance .....	73
During Operation .....	36	Cooling System Safety .....	73
During Operation Safety .....	36	Checking the Cooling System .....	73
Starting the Engine .....	37	Servicing the Engine-Cooling System .....	73
Shutting Off the Engine .....	38	Brake Maintenance .....	74
Understanding Smart Power® Traction .....	38	Adjusting the Service Brakes .....	74
Performing a Fan-Reverse Operation .....	38	Belt Maintenance .....	75
Understanding Auto Idle .....	38	Servicing the Alternator Belt .....	75
Using the Cruise Control .....	38	Servicing the Air Conditioner Compressor Belt .....	75
Diesel Particulate Filter Regeneration .....	38	Tensioning the Blade-Drive Belts .....	75
Using the Engine-Speed Switch .....	50	Replacing the Blade-Drive Belt .....	76
Adjusting the Mowing Speed .....	50	Hydraulic System Maintenance .....	77
Adjusting the Transport Speed .....	51	Hydraulic System Safety .....	77
Understanding the Operating Characteristics of the Machine .....	51	Checking the Hydraulic Fluid .....	77
Operating Tips .....	52	Changing the Hydraulic Fluid .....	78
After Operation .....	54	Replacing the Hydraulic Filters .....	78
After Operation Safety .....	54	Checking the Hydraulic Lines and Hoses .....	79
Pushing or Towing the Machine .....	54	Adjusting the Counterbalance Pressure .....	79
Locating the Jacking Points .....	54	Cutting Unit Maintenance .....	80
Hauling the Machine .....	55	Pivoting (Tilting) the Center Mower Deck to the Upright Position .....	80
Locating the Tie-Down Points .....	55		

# Safety

This machine has been designed in accordance with CEN standard ANSI B71.4-2017 and EN ISO 5395:2013 when the proper CE Kits have been installed, per the Declaration of Conformity.

## General Safety

This product is capable of amputating hands and feet and of throwing objects. Always follow all safety instructions to avoid serious personal injury.

Using this product for purposes other than its intended use could prove dangerous to you and bystanders.

- Read and understand the contents of this *Operator's Manual* before starting the engine.
- Use your full attention while operating the machine. Do not engage in any activity that causes distractions; otherwise, injury or property damage may occur.
- Do not put your hands or feet near moving components of the machine.
- Do not operate the machine without all guards and other safety protective devices in place and working on the machine.
- Keep clear of any discharge opening. Keep bystanders and pets a safe distance away from the machine.
- Keep children out of the operating area. Never allow children to operate the machine.
- Stop the machine, shut off the engine, remove the key, and wait for all moving parts to stop before servicing, fueling, or unclogging the machine.

Improperly using or maintaining this machine can result in injury. To reduce the potential for injury, comply with these safety instructions and always pay attention to the safety-alert symbol, which means Caution, Warning, or Danger—personal safety instruction. Failure to comply with these instructions may result in personal injury or death.

You can find additional safety information where needed throughout this *Operator's Manual*.

Pivoting the Center Mower Deck Down .....	80
Adjusting the Mower-Deck Pitch .....	81
Servicing the Caster-Arm Bushings .....	81
Servicing the Caster Wheels and Bearings.....	82
Replacing the Mower-Deck-Hinge Covers .....	83
Blade Maintenance .....	83
Blade Safety .....	83
Checking for a Bent Blade .....	83
Removing and Installing the Mower Blade(s) .....	84
Inspecting and Sharpening the Mower Blade(s) .....	84
Correcting a Mower-Deck Mismatch .....	85
Cab Maintenance .....	86
Cleaning the Cab .....	86
Cleaning the Cab Air Filters .....	86
Cleaning the Cab Pre-Filter .....	87
Cleaning the Air-Conditioning Coil .....	87
Storage .....	88
Preparing the Traction Unit .....	88
Preparing the Engine .....	88



# Engine-Emission Certification

The engine in this machine is EPA Tier 4 Final and EU Stage 3b emissions compliant.

## Safety and Instructional Decals



Safety decals and instructions are easily visible to the operator and are located near any area of potential danger. Replace any decal that is damaged or missing.



1

58-6520

decal58-6520

1. Grease

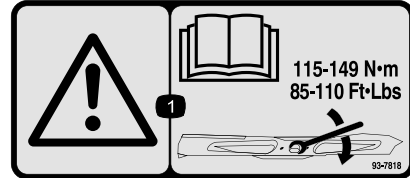

93-7818

decal93-7818

1. Warning—read the *Operator's Manual* for instructions on torquing the blade bolt/nut to 115 to 149 N·m (85 to 110 ft-lb).

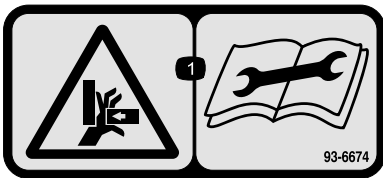

93-6674

decal93-6674

1. Crushing hazard, hand—read the instructions before servicing or performing maintenance.

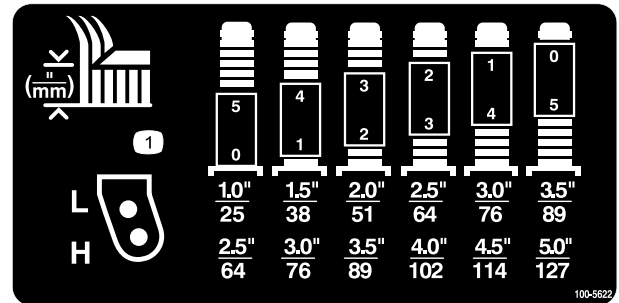

100-5622

decal100-5622

1. Height-of-cut adjustment

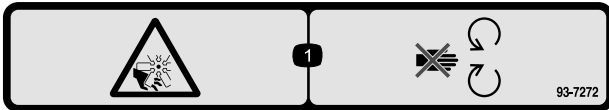

93-7272

decal93-7272

1. Cutting/dismemberment hazard; fan—stay away from moving parts.

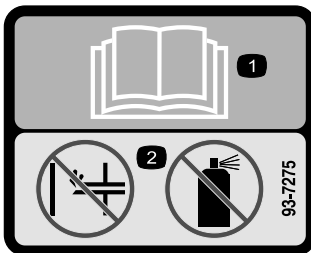

93-7275

decal93-7275

1. Read the *Operator's Manual*.
2. Do not use starting aids.

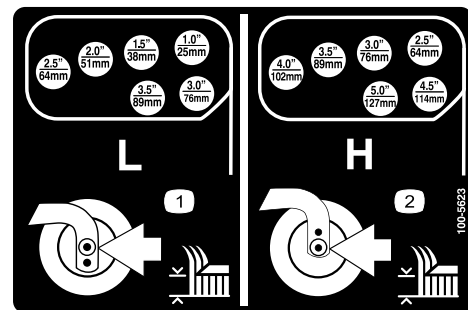

100-5623

decal100-5623

1. Low height-of-cut adjustment
2. High height-of-cut adjustment

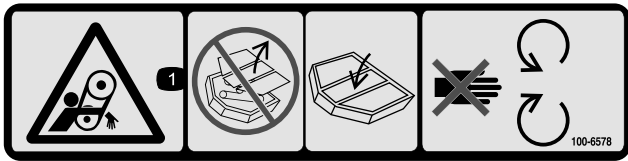

100-6578

decal100-6578

1. Entanglement hazard, belt—do not operate the machine with the shields or guards removed; always keep the shields and guards in place; stay away from moving parts.

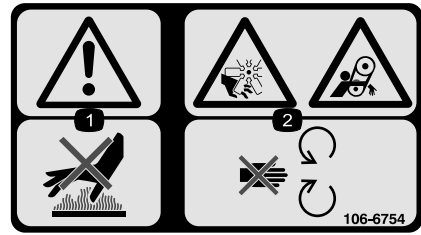

106-6754

decal106-6754

1. Warning—do not touch the hot surface.
2. Cutting/dismemberment hazard, fan and entanglement hazard, belt—stay away from moving parts.

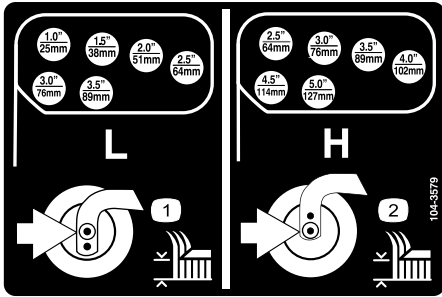

104-3579

decal104-3579

1. Low height-of-cut adjustment
2. High height-of-cut adjustment

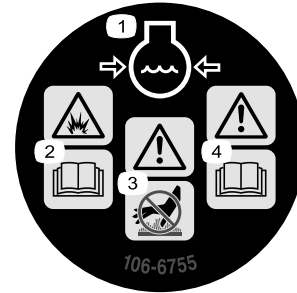

106-6755

decal106-6755

1. Engine coolant under pressure.
2. Explosion hazard—read the *Operator's Manual*.
3. Warning—do not touch the hot surface.
4. Warning—read the *Operator's Manual*.

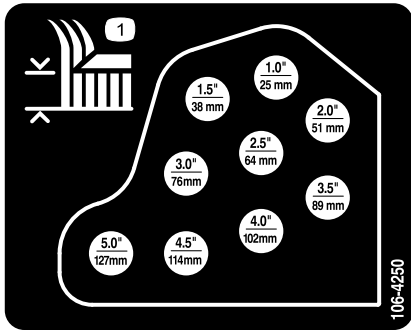

106-4250

decal106-4250

1. Height-of-cut

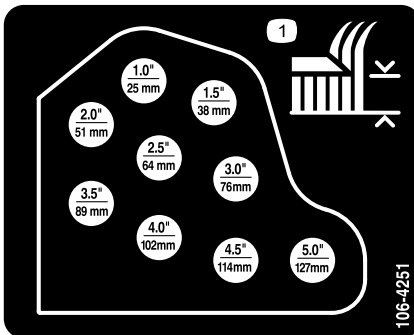

106-4251

decal106-4251

1. Height-of-cut

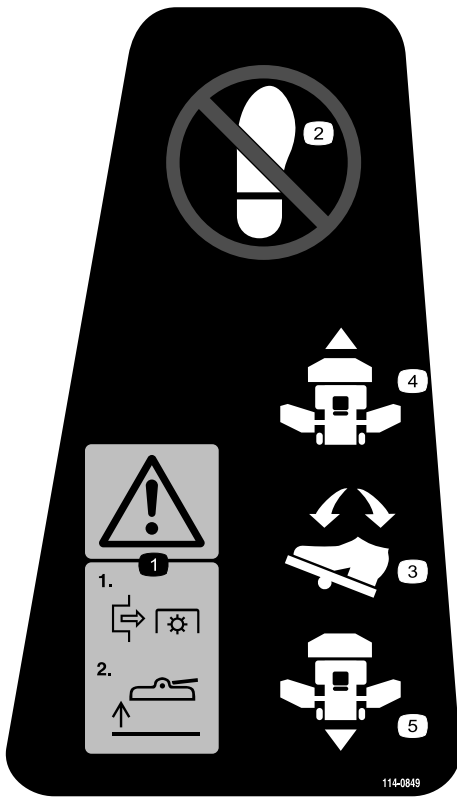

**114-0849**

decal114-0849

1. Warning—1) Disengage the PTO; 2) Raise the deck
2. Do not place your foot here.
3. Direction pedal
4. Forward direction
5. Reverse direction

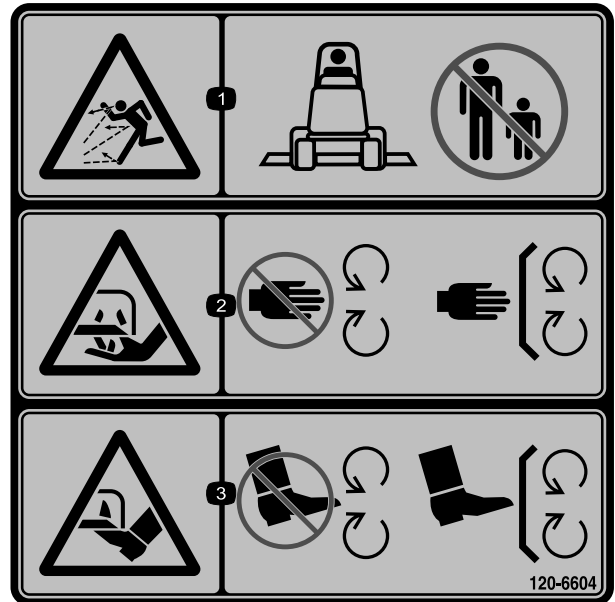

decal120-6604

**120-6604**

1. Thrown object hazard—keep bystanders away from the machine.
2. Cutting/dismemberment hazard of hand, mower blade—stay away from moving parts, keep all guards and shields in place.
3. Cutting/dismemberment hazard of foot, mower blade—stay away from moving parts, keep all guards and shields in place.

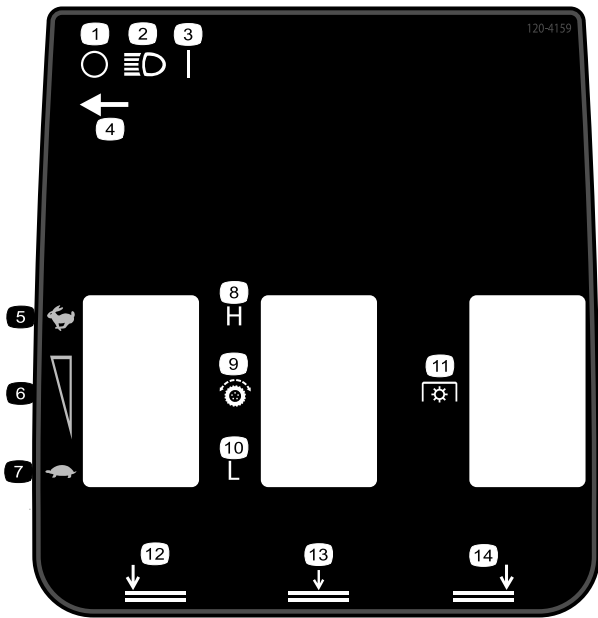

**120-4159**

decal120-4159

- |                              |                         |
|------------------------------|-------------------------|
| 1. Off                       | 8. High                 |
| 2. Lights                    | 9. Traction drive       |
| 3. On                        | 10. Low                 |
| 4. Light switch location     | 11. Power takeoff (PTO) |
| 5. Fast                      | 12. Left deck—lower     |
| 6. Variable speed adjustment | 13. Center deck—lower   |
| 7. Slow                      | 14. Right deck—lower    |

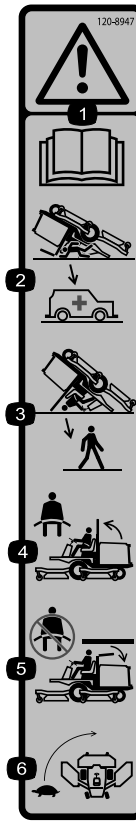

**120-8947**

decal120-8947

- |   |   |
|---|---|
| 1. Warning—read the <i>Operator's Manual</i> .                | 4. If the roll bar is raised, wear the seat belt.         |
| 2. There is no rollover protection when the roll bar is down. | 5. If the roll bar is lowered, do not wear the seat belt. |
| 3. There is rollover protection when the roll bar is up.      | 6. Drive slowly when turning.                             |

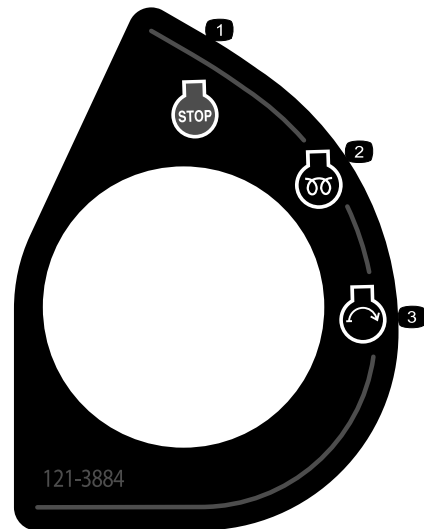

**121-3884**

decal121-3884

- |                    |                 |
|--------------------|-----------------|
| 1. Engine—shut off | 3. Engine—start |
| 2. Engine—preheat  |                 |

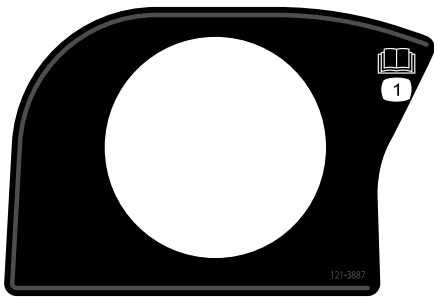

**121-3887**

decal121-3887

1. Read the *Operator's Manual*.

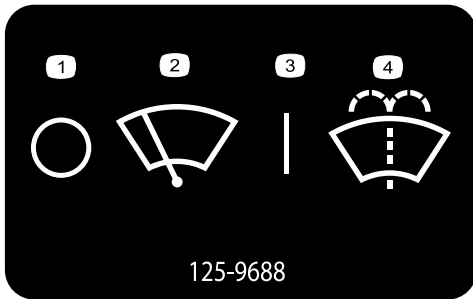

**125-9688**

decal125-9688

- |                          |                                  |
|--------------------------|----------------------------------|
| 1. Windshield wipers—off | 3. Windshield wipers—on          |
| 2. Windshield wipers     | 4. Spray windshield-washer fluid |

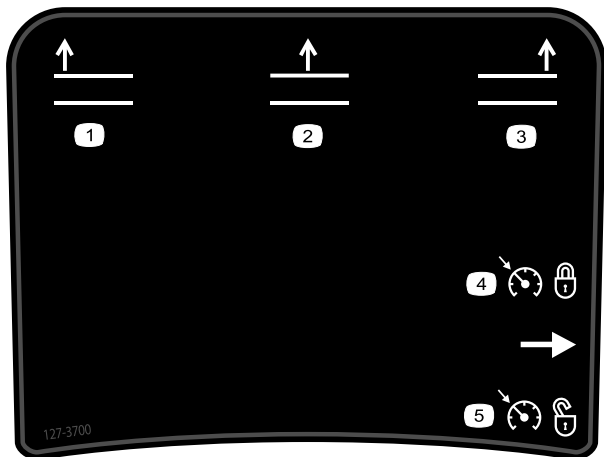

**127-3700**

decal127-3700

- |                           |                             |
|---------------------------|-----------------------------|
| 1. Raise the left deck.   | 4. Lock the engine speed.   |
| 2. Raise the center deck. | 5. Unlock the engine speed. |
| 3. Raise the right deck.  |                             |

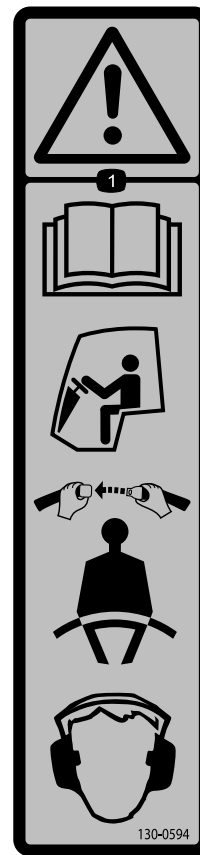

**130-0594**

decal130-0594

1. Warning—read the *Operator's Manual*; when sitting in the cab, always wear a seat belt; wear hearing protection.

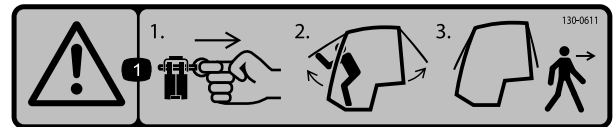

**130-0611**

decal130-0611

1. Warning—1) Remove the pin; 2) Raise the doors; 3) Exit the cab.

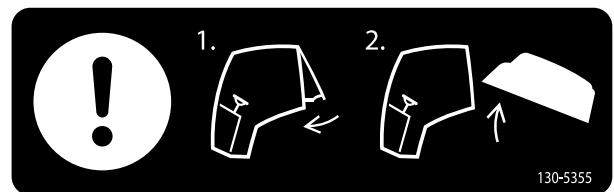

**130-5355**

decal130-5355

1. Close the rear window.
2. Raise the hood.

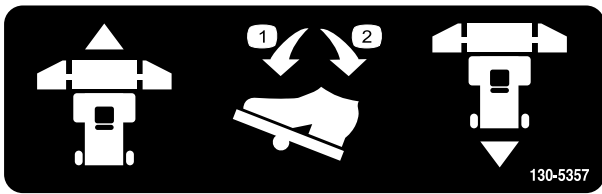

130-5357

decal130-5357

**130-5357**

1. Push forward to move forward.
2. Push back to reverse.

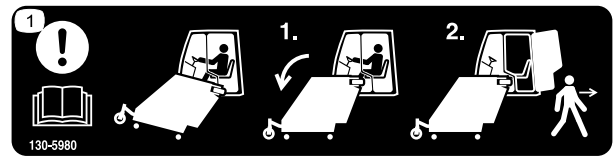

130-5980

decal130-5980

**130-5980**

1. Attention; read the *Operator's Manual*—To leave the machine: 1) Lower the cutting deck; 2) Leave the machine.

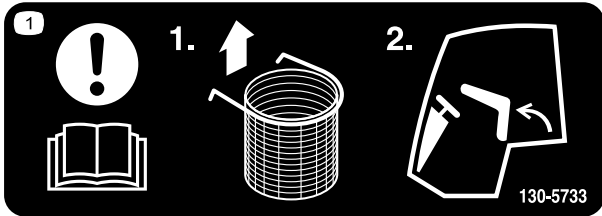

130-5733

decal130-5733

**130-5733**

1. Attention; read the *Operator's Manual*—1) Remove the optional trash bag; 2) Tilt the seat forward.

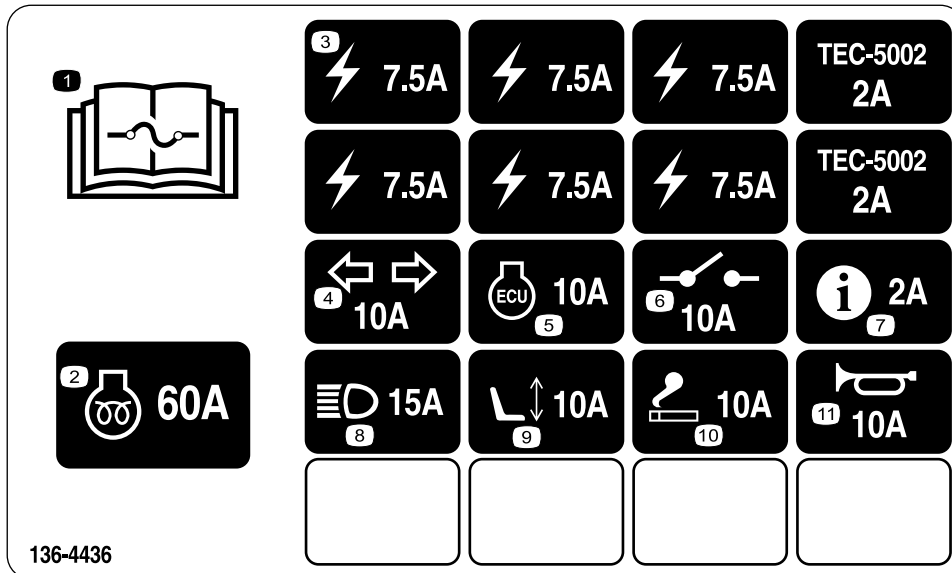

136-4436

**136-4436**

decal136-4436

1. Read the *Operator's Manual* for information on fuses.
2. Engine preheat—60 A
3. Power supply—7.5 A
4. Turn signals—10 A
5. Engine control unit—10 A
6. System power—10 A
7. Infocenter—2 A
8. Headlights—15 A
9. Power seat—10 A
10. Lighter—10 A
11. Horn—10 A

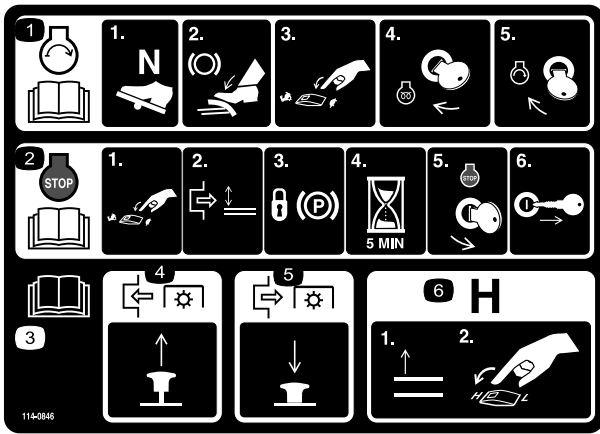

**114-0846**

decal114-0846

- |  |  |
|--|--|
| <ol style="list-style-type: none"> <li>1. Read the <i>Operator's Manual</i> for information on starting the engine—1) Set to neutral; 2) Set the brake; 3) Set the engine speed to slow; 4) Turn the ignition key to preheat; 5) Turn the ignition key to engine start.</li> <li>2. Read the <i>Operator's Manual</i> for information on shutting off the engine—1) Set the engine speed to slow; 2) Disengage the deck; 3) Lock the parking brake; 4) Wait 5 minutes; 5) Turn the ignition key to shut off the engine; 6) Remove the key from the key switch.</li> <li>3. Read the <i>Operator's Manual</i>.</li> </ol> | <ol style="list-style-type: none"> <li>4. Pull out the knob to run the PTO.</li> <li>5. Push in the knob to shut off the PTO.</li> <li>6. Raise the decks to go to H range.</li> </ol> |
|--|--|



decalbatterysymbols

**Battery Symbols**

Some or all of these symbols are on your battery

- |   |  |
|---|--|
| <ol style="list-style-type: none"> <li>1. Explosion hazard</li> <li>2. No fire, open flame, or smoking</li> <li>3. Caustic liquid/chemical burn hazard</li> <li>4. Wear eye protection.</li> <li>5. Read the <i>Operator's Manual</i>.</li> </ol> | <ol style="list-style-type: none"> <li>6. Keep bystanders a safe distance away from the battery.</li> <li>7. Wear eye protection; explosive gases can cause blindness and other injuries.</li> <li>8. Battery acid can cause blindness or severe burns.</li> <li>9. Flush eyes immediately with water and get medical help fast.</li> <li>10. Contains lead; do not discard</li> </ol> |
|---|--|



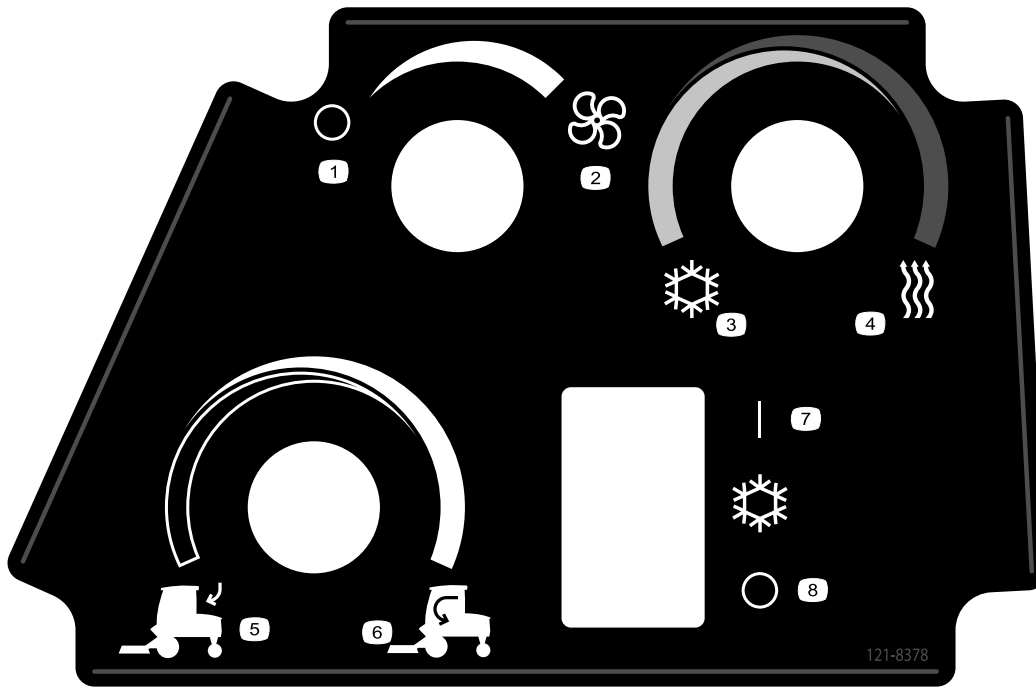

121-8378

decal121-8378

- |                |             |                 |                                      |
|----------------|-------------|-----------------|--------------------------------------|
| 1. Fan—off     | 3. Cold air | 5. External air | 7. Air conditioner—on (If equipped)  |
| 2. Fan—on full | 4. Hot air  | 6. Internal air | 8. Air conditioner—off (If equipped) |

### GROUNDMASTER 4100, MODEL 30604 & 30608 QUICK REFERENCE AID

1

**CHECK/SERVICE (DAILY)**

1. ENGINE OIL LEVEL
2. HYDRAULIC FLUID LEVEL
3. ENGINE COOLANT LEVEL
4. FUEL - DIESEL ONLY
5. FUEL/WATER SEPARATOR
6. FAN BELT TENSION
7. RADIATOR SCREEN
8. AIR CLEANER
9. BRAKE FUNCTION
10. INTERLOCK SYSTEM
11. TIRE PRESSURE - 25 PSI/1.70 BAR
12. GREASE POINTS (4)

SEE OPERATOR'S MANUAL FOR 50 HR INTERVAL GREASE POINTS.

**SPECIFICATIONS/CHANGE INTERVALS**

SEE OPERATOR'S MANUAL FOR INITIAL CHANGES.	FLUID TYPE	CAPACITY	CHANGE INTERVAL		FILTER PART NO.
			FLUID	FILTER	
ENGINE OIL	30604 15W-40, CI-4	6 QUARTS	250 HOURS	250 HOURS	125-7025 (A)
	30608 15W-40, CI-4				75-1310 (B)
HYDRAULIC FLUID	ISO VG 46/68	775 GALLONS	800 HOURS	800 HOURS	94-2621 (C)
HYDRAULIC BREATHER				800 HRS/YRLY	115-9793 (D)
PRIMARY AIR FILTER				SEE SERVICE INDICATOR	108-3814 (E)
SAFETY AIR FILTER				SEE OPERATOR'S MANUAL	108-3816 (F)
FUEL SYSTEM	> 32 F NO. 2 DIESEL	21 GALLONS	800 HOURS DRAIN/FLUSH	400 HOURS/YEARLY	30604 110-9049 (G)
	< 32 F NO. 1 DIESEL				125-2915 (H)
REAR AXLE	85W-140	80 OUNCES	800 HOURS		110-4812 BREATHER (I)
PLANETARY DRIVE	85W-140	22 OUNCES	800 HOURS		
ENGINE COOLANT	50% WATER 50% ETHYLENE GLYCOL	9 QUARTS	DRAIN & FLUSH EVERY 2 YRS.		

130-6042

decal130-6042

1. Read the *Operator's Manual* for maintenance information.

**GROUNDMASTER 4110, MODEL 30643 & 30644  
QUICK REFERENCE AID**

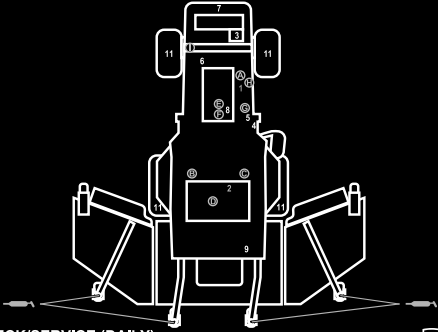

**CHECK/SERVICE (DAILY)**

- |                          |                                     |
|--------------------------|-------------------------------------|
| 1. ENGINE OIL LEVEL      | 8. AIR CLEANER                      |
| 2. HYDRAULIC FLUID LEVEL | 9. BRAKE FUNCTION                   |
| 3. ENGINE COOLANT LEVEL  | 10. INTERLOCK SYSTEM                |
| 4. FUEL - DIESEL ONLY    | 11. TIRE PRESSURE - 25 PSI/1.70 BAR |
| 5. FUEL/WATER SEPARATOR  | 12. GREASE POINTS (4)               |
| 6. FAN BELT TENSION      | SEE OPERATOR'S MANUAL FOR           |
| 7. RADIATOR SCREEN       | 50 HR INTERVAL GREASE POINTS.       |

**SPECIFICATIONS/CHANGE INTERVALS**

SEE OPERATOR'S MANUAL FOR INITIAL CHANGES.	FLUID TYPE	CAPACITY	CHANGE INTERVAL		FILTER PART NO.
			FLUID	FILTER	
ENGINE OIL	30643 15W-40, CJ-4 30644 15W-40, CJ-4	6 QUARTS	250 HOURS	250 HOURS	125-7025 (A)
HYDRAULIC FLUID	ISO VG 46/68	7.75 GALLONS	800 HOURS	800 HOURS	75-1310 (B) 94-2621 (C)
HYDRAULIC BREATHER				800 HRS/YRLY	115-9793 (D)
PRIMARY AIR FILTER				SEE SERVICE INDEXER	108-3814 (E)
SAFETY AIR FILTER				SEE OPERATOR'S MANUAL	108-3816 (F)
FUEL SYSTEM	> 32 F	NO. 2 DIESEL	800 HOURS	400 HOURS YEARLY	30643 110-3048 (G) 30644 125-2915 (H) 125-3752 (I)
	< 32 F	NO. 1 DIESEL	21 GALLONS	DRAIN/FLUSH	
REAR AXLE	85W-140	80 OUNCES	800 HOURS		110-4812 BREATHER (J)
PLANETARY DRIVE	85W-140	22 OUNCES	800 HOURS		
ENGINE COOLANT	50% WATER 50% ETHYL GLYCOL	14.5 QUARTS	DRAIN & FLUSH EVERY 2 YRS.		

**130-6048**

decal130-6048

1. Read the *Operator's Manual*.

**WARNING:** This product can expose you to chemicals including diesel engine exhaust, which is known to the State of California to cause cancer, and carbon monoxide, which is known to the State of California to cause birth defects or other reproductive harm. For more information go to [www.P65Warnings.ca.gov](http://www.P65Warnings.ca.gov). For more information, please visit [www.toro.com/CAProp65](http://www.toro.com/CAProp65).

**CALIFORNIA SPARK ARRESTER WARNING**

Operation of this equipment may create sparks that can start fires around dry vegetation. A spark arrester may be required. The operator should contact local fire agencies for laws or regulations relating to fire prevention requirements.

decal133-5618

**133-5618**

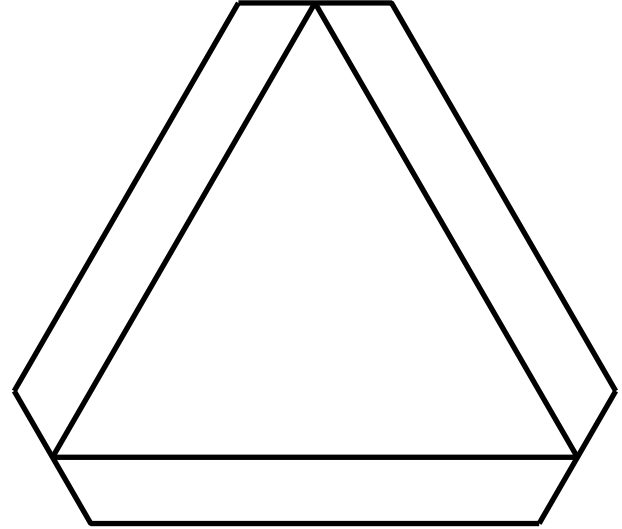

**120-0250**

decal120-0250

1. Slow-moving vehicle

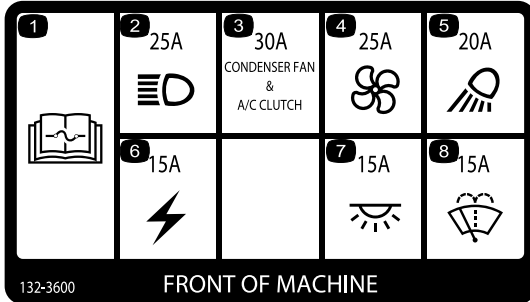

132-3600

**FRONT OF MACHINE**

decal132-3600

**132-3600**

Cab only

- |   |                             |
|---|-----------------------------|
| 1. Read the <i>Operator's Manual</i> for more information on fuses. | 5. Working light (20 A)     |
| 2. Headlight (25 A)   | 6. Auxiliary power (15 A)   |
| 3. Condenser fan and A/C clutch (30 A)                              | 7. Cab light (15 A)         |
| 4. Fan (25 A)   | 8. Windshield wipers (15 A) |

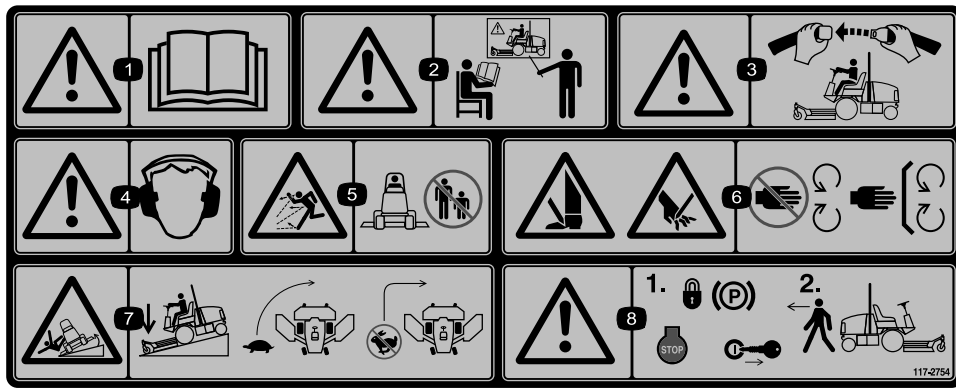

117-2754

decal117-2754

1. Warning—read the *Operator's Manual*.
2. Warning—do not operate this machine unless you are trained.
3. Warning—wear the seat belt when seated in the operator's position and the roll bar is up.
4. Warning—wear hearing protection.
5. Thrown object hazard—keep bystanders a safe distance away from the machine.
6. Cutting hazard of hand or foot—stay away from moving parts; keep all guards in place.
7. Tipping hazard—lower the cutting unit when driving down slopes; slow machine before turning, do not turn at high speeds
8. Warning—lock the parking brake, shut off the engine, and remove the key from the ignition before leaving the machine.

# Setup

## Loose Parts

Use the chart below to verify that all parts have been shipped.

Procedure	Description	Qty.	Use
<b>1</b>	No parts required	–	Grease the machine.
<b>2</b>	No parts required	–	Check the tire pressure.
<b>3</b>	No parts required	–	Check the fluid levels.

## Media and Additional Parts

Description	Qty.	Use
Operator's Manual	1	Review before operating machine
Engine Owner's Manual	1	Use to reference engine information
Declaration of Conformity	1	
Caster Cap Wrench	1	Use to adjust caster wheel assemblies

**Note:** Determine the left and right sides of the machine from the normal operating position.

# 1

## Greasing the Machine

No Parts Required

### Procedure

Grease the machine before use; refer to [Lubrication \(page 61\)](#).

**Important:** Failure to properly grease the machine will result in premature failure of critical parts.

# 2

## Checking the Tire Pressure

No Parts Required

### Procedure

Check the tire pressure; refer to [Checking the Tire Pressure \(page 23\)](#).

**Important:** Maintain pressure in all tires to ensure a good quality-of-cut and proper machine performance. Do not underinflate the tires.

# 3

## Checking the Fluid Levels

No Parts Required

### Procedure

1. Check the engine-oil level; refer to [Checking the Engine-Oil Level \(page 63\)](#).
2. Check the hydraulic fluid level; refer to [Checking the Hydraulic Fluid \(page 77\)](#).
3. Check the cooling system; refer to [Checking the Cooling System \(page 73\)](#).
4. Check the planetary-gear-drive oil; refer to [Checking the Planetary-Gear-Drive Oil \(page 70\)](#).
5. Check the rear-axle lubricant; refer to [Checking the Rear-Axle Lubricant \(page 71\)](#).
6. Check the rear-axle-gearbox lubricant; refer to [Checking the Rear-Axle-Gearbox Lubricant \(page 71\)](#).

# Product Overview

## Controls

**Note:** Determine the left and right sides of the machine from the normal operating position.

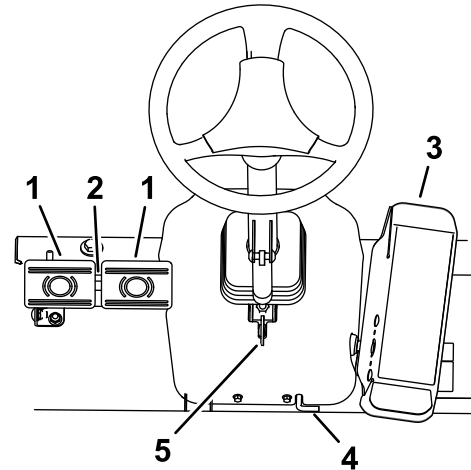

Figure 3

g203048

- |                        |                        |
|------------------------|------------------------|
| 1. Brake pedal         | 4. Parking brake       |
| 2. Pedal-locking latch | 5. Tilt-steering lever |
| 3. Traction pedal      |                        |

## Traction Pedal

To stop the machine, reduce the amount of foot pressure that you apply to the traction pedal until the pedal returns to the NEUTRAL position ([Figure 3](#)).

## Brake Pedals

There are 2 foot pedals that operate individual wheel brakes for turning assistance, parking, and to aid in better side-hill traction. A latch connects the pedals for parking-brake operation and transport ([Figure 3](#)).

## Pedal-Locking Latch

The pedal-locking latch connects the pedals together to engage the parking brake ([Figure 3](#)).

## Tilt-Steering Lever

Press the tilt-steering lever down to tilt the steering wheel to the desired position, then release the lever to lock the adjustment ([Figure 3](#)).

## Parking-Brake Latch

A knob on the left side of the console actuates the parking-brake lock ([Figure 3](#)).

To engage the parking brake, connect the pedals with the locking latch, push down on both pedals, and pull the parking-brake latch out. To release the parking brake, press both pedals until the parking-brake latch retracts.

## Key Switch

The key switch (Figure 4) has 3 positions: OFF, ON/PREHEAT, and START.

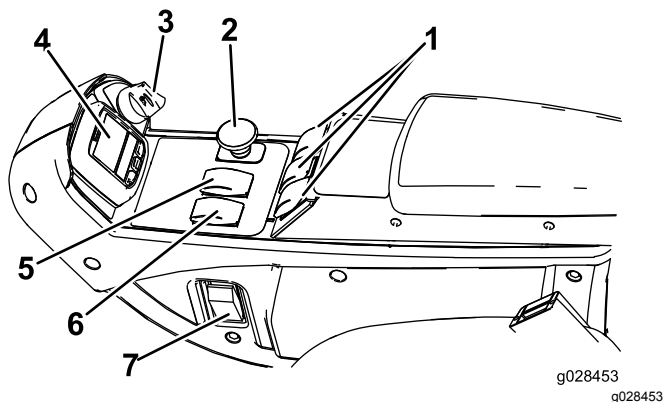

Figure 4

- |                  |                            |
|------------------|----------------------------|
| 1. Lift switches | 5. High-Low speed control  |
| 2. PTO switch    | 6. Engine-speed switch     |
| 3. Key switch    | 7. Light switch (optional) |
| 4. InfoCenter    |                            |

## Engine-Speed Switch

The engine-speed switch (Figure 4) has 2 modes to change the engine speed. Tap the switch to increase or decrease the engine speed in 100 rpm increments. Hold down the switch to automatically move to High or Low idle, depending on which end of the switch you press.

## PTO Switch

The PTO switch has 2 positions: OUT (START) and IN (STOP). Pull the PTO button out to engage the mower-deck blades. Push the button in to disengage the mower-deck blades (Figure 4).

## High-Low Speed-Control Switch

The High-Low speed-control switch allows the speed range to increase for transport of the machine (Figure 4).

Mower decks do not operate in high range. To switch between the HIGH and LOW range, raise the decks, disengage the PTO and the cruise control, move the traction pedal in the NEUTRAL position, and have the machine move at a slow speed.

## Lift Switches

The lift switches raise and lower the mower decks (Figure 4). Press the switches forward to lower the mower decks and rearward to raise the mower decks. When starting the machine, with the mower decks in the down position, press the lift switch down to allow the mower decks to float and mow.

**Note:** The decks do not lower while in the high-speed range and they do not raise or lower if you are out of the seat while the engine is running. Also, the decks lower with the key in the ON position and you are in the seat.

## Cruise-Control Switch

The cruise-control switch locks in the pedal position to maintain the desired ground speed (Figure 5). Pressing the rear of the switch turns off the cruise control, the middle position of the switch enables the cruise-control function, and the front of the switch sets the desired ground speed.

**Note:** Pressing either brake pedal or moving the traction pedal into the REVERSE position, for 1 second, also disengages the pedal position.

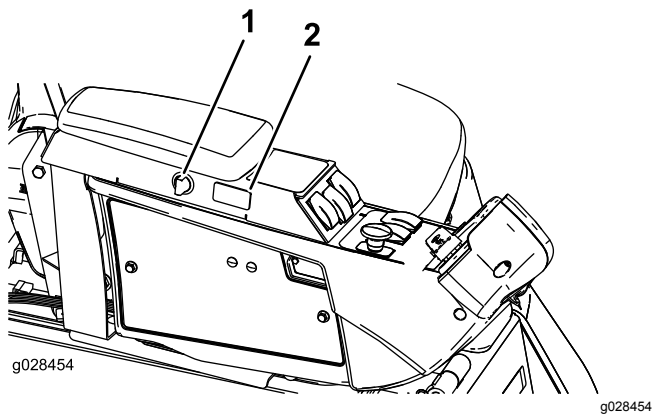
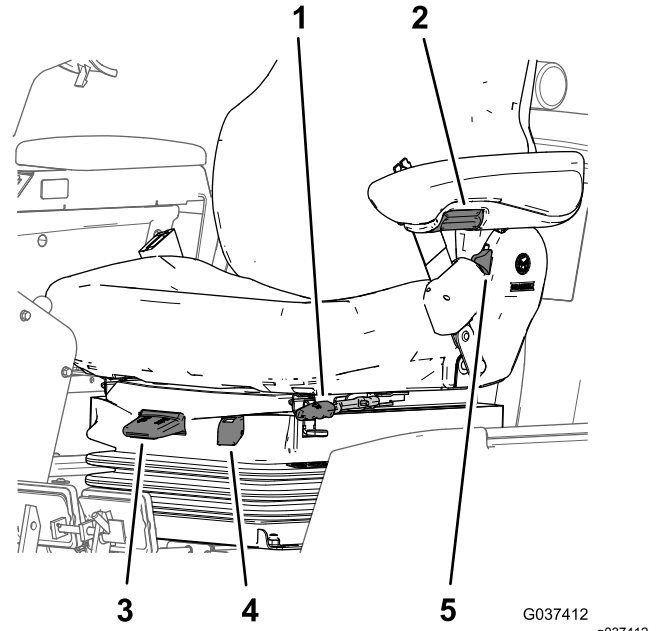

**Figure 5**

1. Power-point port                      2. Cruise-control switch

## Power-Point Port

Use the power-point port to power optional electrical accessories (Figure 5).



**Figure 6**

1. Seat-adjustment lever                      4. Weight gauge  
 2. Armrest-adjustment knob                5. Seat-back adjustment lever  
 3. Weight-adjustment lever

### Armrest-Adjustment Knob

Rotate the knob to adjust the armrest angle (Figure 6).

### Seat-Back-Adjustment Lever

Move the lever to adjust the seat-back angle (Figure 6).

### Weight Gauge

The weight gauge indicates when the seat is adjusted to the weight of the operator (Figure 6). Adjust the height by positioning the suspension within the range of the green region.

### Weight-Adjustment Lever

Use this lever to adjust to the proper weight of the operator (Figure 6). Pull up the lever to increase the air pressure and push down to decrease the air pressure. The proper adjustment is correct when the weight gauge is in the green region.



# Cab Controls

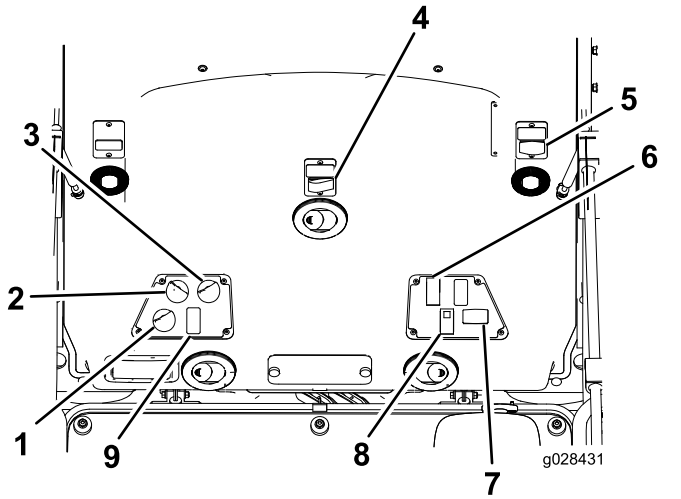

Figure 7

- |                              |                            |
|------------------------------|----------------------------|
| 1. Air-recirculation control | 5. Power outlet            |
| 2. Fan control               | 6. Lights switch           |
| 3. Temperature control       | 7. Flashers switch         |
| 4. Windshield-wiper switch   | 8. Air-conditioning switch |

## Air Recirculation Control

Sets the cab to either recirculate the air in the cabin or to draw air into the cabin from outside (Figure 7).

- Set it to recirculate the air when using the air conditioning.
- Set it to draw air in when using the heater or fan.

## Fan-Control Knob

Rotate the fan-control knob to regulate the speed of the fan (Figure 7).

## Temperature-Control-Knob

Rotate the temperature-control knob to regulate the air temperature in the cab (Figure 7).

## Windshield-Wiper Switch

Use this switch to turn the wind shield wipers on or off (Figure 7).

## Air-Conditioning Switch

Use this switch to turn the air conditioning on or off (Figure 7).

## Power Outlet

Use this 15 A, 12 V DC power outlet to power compatible devices (Figure 7).

## Lights Switch

Use this switch to turn the headlights and tail light on or off (Figure 7).

## Flashers Switch

Use this switch to turn the flashers (hazard lights) on or off (Figure 7).

## Windshield Latch

Lift up the latches to open the windshield (Figure 8). Press in the latch to lock the windshield to the OPEN position. Pull out and down on the latch to close and secure the windshield.

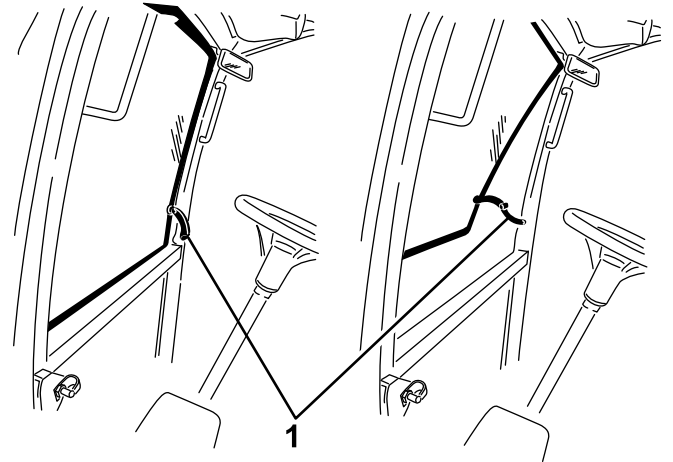

Figure 8

1. Windshield latch

## Rear Window Latch

Lift up the latches to open the rear window. Press in on the latch to lock the window in OPEN position. Pull out and down on the latch to close and secure the window (Figure 8).

**Important:** Close the rear window before opening the hood or damage may occur to the hood or rear window.

# Specifications

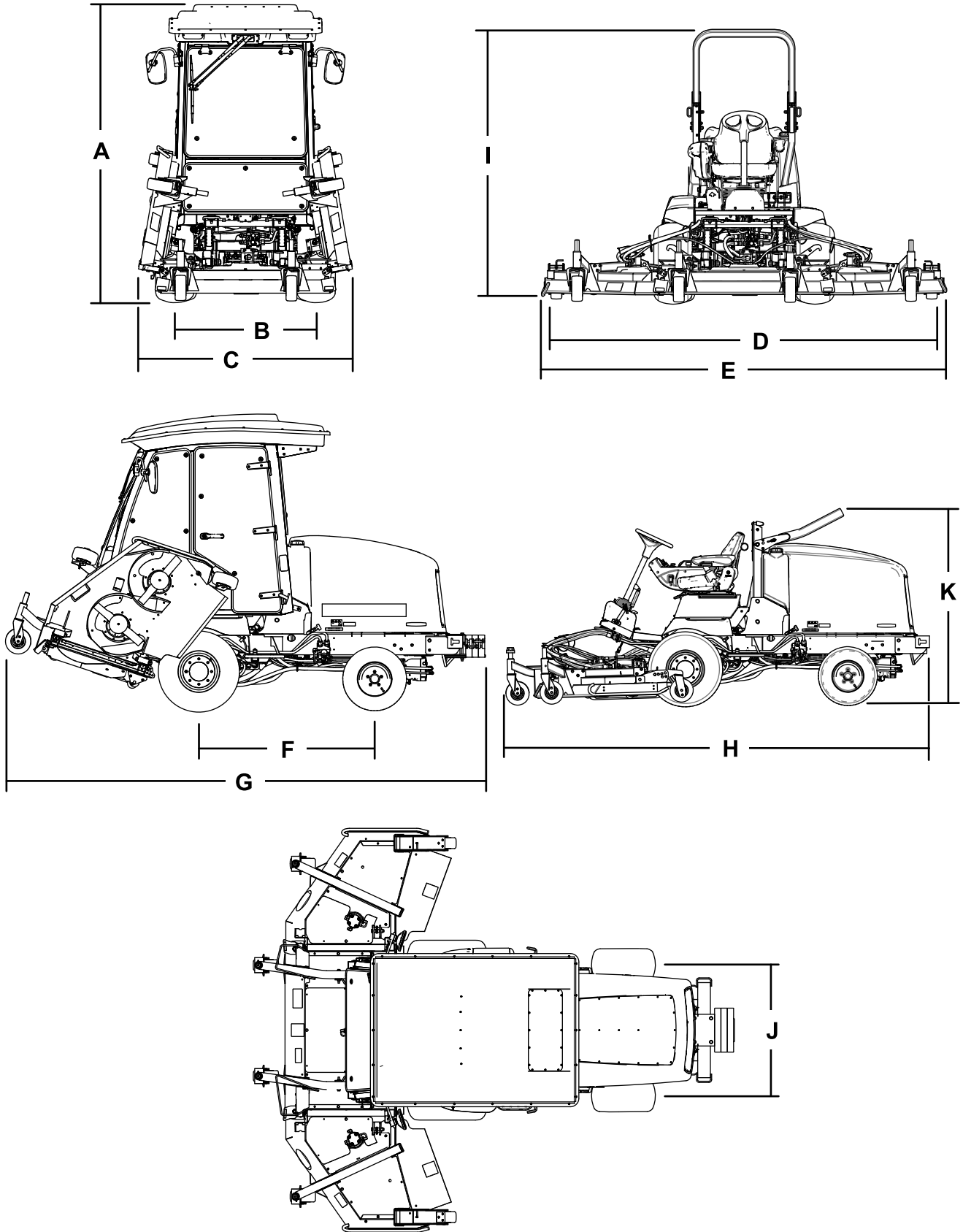

Figure 9

g203228

Description	Figure 9 reference	Dimension or Weight	
Height with cab	A	237 cm (93 inches)	
Height with roll bar raised	I	217 cm (85 inches)	
Height with roll bar lowered	K	173 cm (68 inches)	
Overall length	H	186 cm(152 inches)	
Length for storage	G	184 cm (151 inches)	
Width of cut			
	overall	D	315 cm (124 inches)
	front cutting unit		137 cm (54 inches)
	side cutting unit		94 cm (37 inches)
	front and one side cutting unit		226 cm (89 inches)
Overall width			
	cutting units down	E	323 cm (127 inches)
	cutting units up (transport position)	C	180 cm (71 inches)
Wheel base	F	141 cm (56 inches)	
Wheel tread (tire center to center)			
	front	B	114 cm (45 inches)
	rear	J	107 cm (42 inches)
Ground clearance		15 cm (6 inches)	
Net weight with cab		2165 kg (4,774 lb)	
Net weight with roll bar		1922 kg (4,237 lb)	

**Note:** Specifications and design are subject to change without notice.

## Attachments/Accessories

A selection of Toro approved attachments and accessories is available for use with the machine to enhance and expand its capabilities. Contact your Authorized Service Dealer or Distributor or go to [www.Toro.com](http://www.Toro.com) for a list of all approved attachments and accessories.

To ensure optimum performance and continued safety certification of the machine, use only genuine Toro replacement parts and accessories. Replacement parts and accessories made by other manufacturers could be dangerous, and such use could void the product warranty.

# Operation

**Note:** Determine the left and right sides of the machine from the normal operating position.

## Before Operation

### Before Operation Safety

#### General Safety

- Never allow children or untrained people to operate or service the machine. Local regulations may restrict the age of the operator. The owner is responsible for training all operators and mechanics.
- Become familiar with the safe operation of the equipment, operator controls, and safety signs.
- Know how to stop the machine and shut off the engine quickly.
- Check that operator-presence controls, safety switches, and shields are attached and functioning properly. Do not operate the machine unless they are functioning properly.
- Before mowing, always inspect the machine to ensure that the blades, blade bolts, and cutting assemblies are in good working condition. Replace worn or damaged blades and bolts in sets to preserve balance.
- Inspect the area where you will use the machine and remove all objects that the machine could throw.

#### Fuel Safety

- Use extreme care in handling fuel. It is flammable and its vapors are explosive.
- Extinguish all cigarettes, cigars, pipes, and other sources of ignition.
- Use only an approved fuel container.
- Do not remove the fuel cap or fill the fuel tank while the engine is running or hot.
- Do not add or drain fuel in an enclosed space.
- Do not store the machine or fuel container where there is an open flame, spark, or pilot light, such as on a water heater or other appliance.
- If you spill fuel, do not attempt to start the engine; avoid creating any source of ignition until the fuel vapors have dissipated.

## Checking the Engine-Oil Level

Before you start the engine and use the machine, check the oil level in the engine crankcase; refer to [Checking the Engine-Oil Level \(page 63\)](#).

## Checking the Cooling System

Before you start the engine and use the machine, check the cooling system; refer to [Checking the Cooling System \(page 73\)](#).

## Checking the Hydraulic System

Before you start the engine and use the machine, check the hydraulic system; refer to [Checking the Hydraulic Fluid \(page 77\)](#).

## Draining the Water Separator

Drain water or other contaminants from the water separator; refer to [Servicing the Water Separator \(page 67\)](#).

## Filling the Fuel Tank

### Fuel Tank Capacity

Fuel tank capacity: 79 L (21 US gallons)

### Fuel Specification

**Important:** Use only ultra-low sulphur diesel fuel. Fuel with higher rates of sulfur degrades the diesel oxidation catalyst (DOC), which causes operational problems and shortens the service life of engine components.

**Failure to observe the following cautions may damage the engine.**

- Never use kerosene or gasoline instead of diesel fuel.
- Never mix kerosene or used engine oil with the diesel fuel.
- Never keep fuel in containers with zinc plating on the inside.
- Do not use fuel additives.

## Petroleum Diesel

**Cetane rating:** 45 or higher

**Sulfur content:** Ultra-low sulfur (<15 ppm)

### Fuel Table

Diesel fuel specification	Location
ASTM D975 No. 1-D S15 No. 2-D S15	USA
EN 590	European Union
ISO 8217 DMX	International
JIS K2204 Grade No. 2	Japan
KSM-2610	Korea

- Use only clean, fresh diesel fuel or biodiesel fuels.
- Purchase fuel in quantities that can be used within 180 days to ensure fuel freshness.

Use summer-grade diesel fuel (No. 2-D) at temperatures above  $-7^{\circ}\text{C}$  ( $20^{\circ}\text{F}$ ) and winter-grade fuel (No. 1-D or No. 1-D/2-D blend) below that temperature.

**Note:** Use of winter-grade fuel at lower temperatures provides lower flash point and cold flow characteristics which eases starting and reduces fuel filter plugging.

Using summer-grade fuel above  $-7^{\circ}\text{C}$  ( $20^{\circ}\text{F}$ ) contributes toward longer fuel pump life and increased power compared to winter-grade fuel.

## Using Biodiesel

This machine can also use a biodiesel-blended fuel of up to B20 (20% biodiesel, 80% petrodiesel).

**Sulfur content:** Ultra-low sulfur (<15 ppm)

**Biodiesel fuel specification:** ASTM D6751 or EN14214

**Blended fuel specification:** ASTM D975, EN590, or JIS K2204

**Important:** The petroleum diesel portion must be ultra-low sulfur.

Observe the following precautions:

- Biodiesel blends may damage painted surfaces.
- Use B5 (biodiesel content of 5%) or lesser blends in cold weather.
- Monitor seals, hoses, gaskets in contact with fuel as they may degrade over time.
- Fuel filter plugging may occur for a time after you convert to biodiesel blends.
- For more information on biodiesel, contact your authorized Toro distributor.

## Adding Fuel

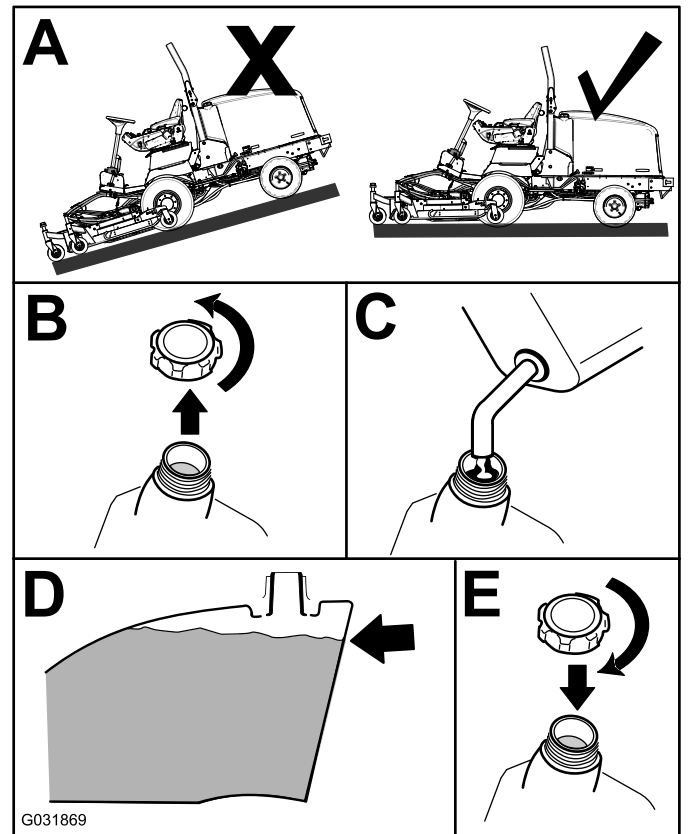

Figure 10

Fill the tank to about 6 to 13 mm ( $1/4$  to  $1/2$  inch) below the top of the tank, not the filler neck, with No. 2-D diesel fuel.

**Note:** If possible, fill the fuel tank after each use; this will minimize possible buildup of condensation inside the fuel tank.

## Checking the Tire Pressure

**Service Interval:** Before each use or daily

### ⚠ DANGER

Low tire pressure decreases machine side-hill stability. This could cause a rollover, which may result in personal injury or death.

**Do not underinflate the tires.**

The correct air pressure in the tires is 172 to 207 kPa (25 to 30 psi).

**Important:** Maintain the recommended pressure in all tires to ensure a good quality of cut and proper machine performance. Do not under-inflate the tires.

**Check the air pressure in all the tires before operating the machine.**

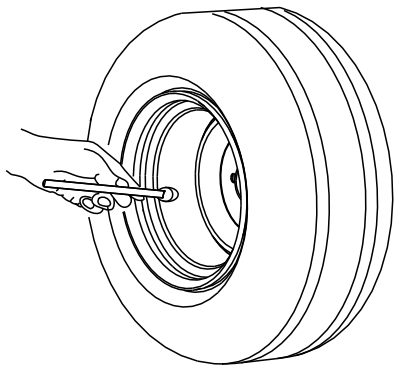

G001055

Figure 11

g001055

## Checking the Torque of the Wheel Lug Nuts

**Service Interval:** After the first hour

After the first 10 hours

Every 200 hours

### **⚠ WARNING**

Failing to maintain proper torque of the wheel-lug nuts could result in personal injury.

Torque the wheel-lug nuts to the proper torque value.

Torque the wheel-lug nuts to 115 to 136 N·m (85 to 100 ft-lb) in the order shown in [Figure 12](#) and [Figure 13](#).

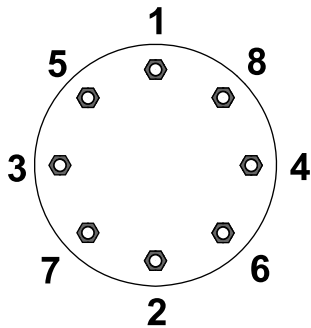

G033358

Figure 12

Front Wheels

g033358

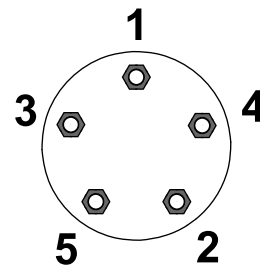

G033359

Figure 13  
Rear Wheels

g033359

## Adjusting the Mirrors

### Cab Model Only

#### Rearview Mirror

While sitting in the seat, adjust the rearview mirror to attain the best view out the rear window ([Figure 14](#)). Pull the lever rearward to tilt the mirror to reduce the brightness and glare of light.

#### Side-View Mirrors

While sitting in the seat, have someone assist to adjust the side-view mirrors to attain the best view around the side of the machine ([Figure 14](#)).

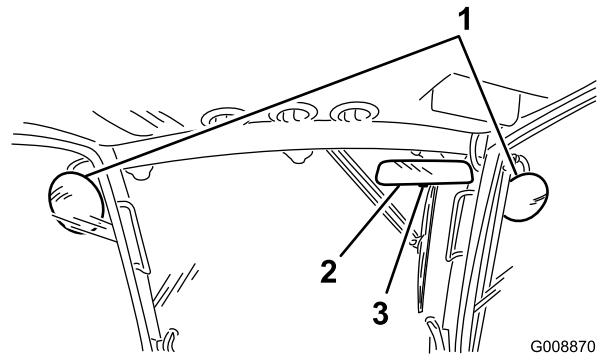

G008870

g008870

Figure 14

1. Side-view mirrors
2. Rearview mirror
3. Lever

# Aiming the Headlights

## Optional Accessory

1. Loosen the mounting nuts and position each headlight so that it points straight ahead.  
**Note:** Tighten the mounting nut just enough to hold the headlight in position.
2. Place a flat piece of sheet metal over the face of the headlight.
3. Mount a magnetic protractor onto the plate.
4. While holding the assembly in place, carefully tilt the headlight downward  $3^\circ$ , then tighten the nut.
5. Repeat the procedure on the other headlight.

# Adjusting the Rollover Protection System (ROPS)

## ⚠ WARNING

To avoid injury or death from rollover: keep the roll bar in the raised locked position and use the seat belt.

Ensure that the seat is secured with the seat latch.

## ⚠ WARNING

There is no rollover protection when the roll bar is in the down position.

- Do not operate the machine on uneven ground or on a hillside with the roll bar in the down position.
- Lower the roll bar only when absolutely necessary.
- Do not wear the seat belt when the roll bar is in the down position.
- Drive slowly and carefully.
- Raise the roll bar as soon as clearance permits.
- Check carefully for overhead clearances (i.e., branches, doorways, electrical wires) before driving under any objects and do not contact them.

# Lowering the Roll Bar

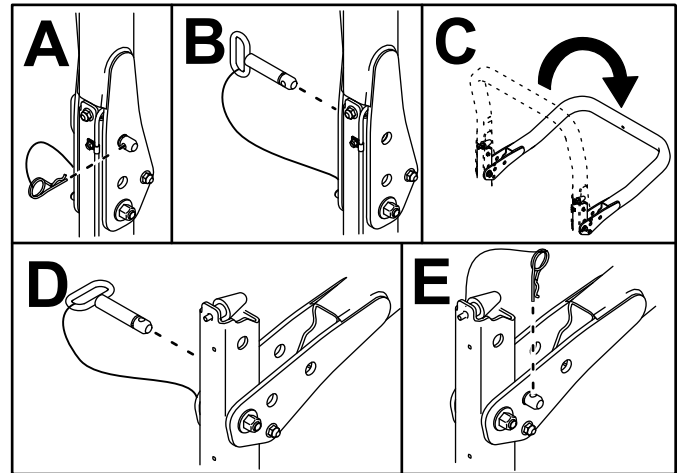

Figure 15

g221650

# Raising the Roll Bar

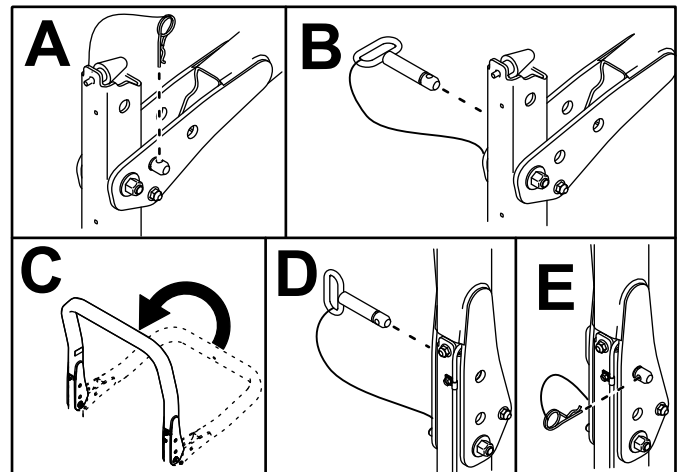

Figure 16

g221651



# Adjusting the Height of Cut

## Center Mower Deck

The height of cut is adjustable from 25 to 127 mm (1 to 5 inches) in 13 mm (1/2 inch) increments. To adjust the height of cut on the center mower deck, position the castor-wheel axles in the upper or lower holes of the castor forks, add or remove an equal number of spacers from the castor forks, and secure the rear chain to the desired hole.

1. Park the machine on a level surface.
2. Start the engine and raise the mower decks to change height of cut.
3. Shut off the engine, engage the parking brake, and remove the key from the ignition after the mower deck is raised.
4. Position the caster-wheel axles in the same holes in all caster forks.

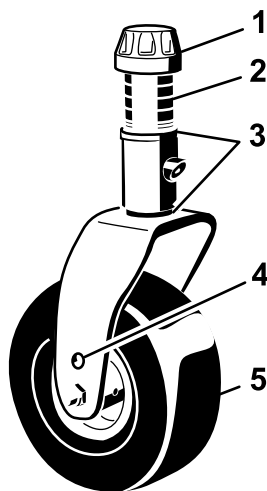

Figure 17

- |                   |                           |
|-------------------|---------------------------|
| 1. Tensioning cap | 4. Top axle-mounting hole |
| 2. Spacers        | 5. Caster wheel           |
| 3. Shims          |                           |

**Note:** When operating in 64 mm (2-1/2 inch) height of cut or higher, install the axle bolt in the lower caster-fork hole to prevent grass buildup between the wheel and the fork. When you operate the machine at a height of cut lower than 64 mm (2-1/2 inches) and detect grass buildup, reverse the machines direction to pull any clippings away from the wheel/fork area.

5. Remove the tensioning cap from the spindle shaft and slide the spindle out of the caster arm (Figure 17).
6. Install 2 shims onto the spindle shaft as they were originally installed.

**Note:** These shims require a level across the entire width of the mower decks. Slide the appropriate number of 13 mm (1/2 inch) spacers (refer to the chart below) onto the spindle shaft to attain the desired height of cut; then slide the washer onto the shaft.

Refer to the following chart to determine the combinations of spacers for the setting (Figure 18):

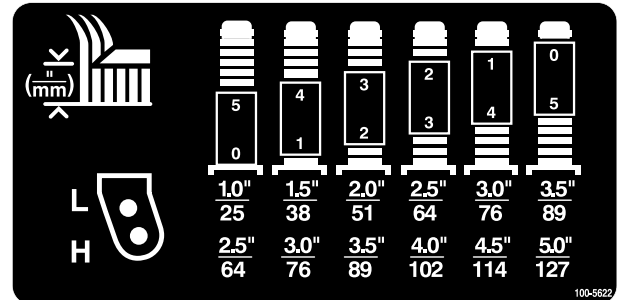

Figure 18

7. Push the caster spindle through the front caster arm.
8. Install the shims (as they were originally installed) and the remaining spacers onto the spindle shaft.
9. Install the tensioning cap to secure the assembly.
10. Remove the hairpin cotter and clevis pin securing the height-of-cut chains to the rear of the mower deck (Figure 19).

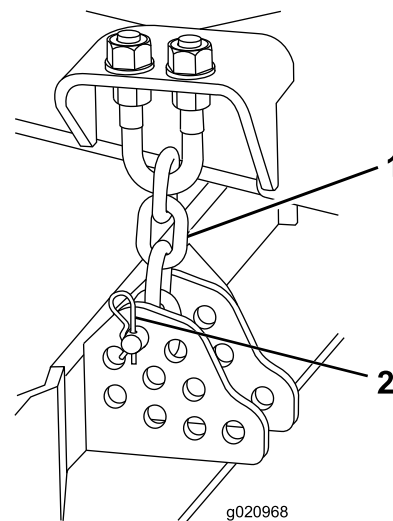

Figure 19

- |                        |                                  |
|------------------------|----------------------------------|
| 1. Height-of-cut chain | 2. Clevis pin and hairpin cotter |
|------------------------|----------------------------------|

11. Mount the height-of-cut chains to the desired height-of-cut hole with the clevis pin and hairpin cotter (Figure 20).

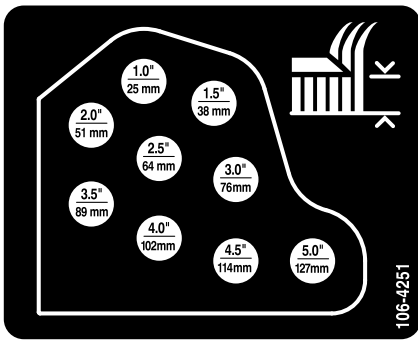

Figure 20

decal106-4251nc

**Note:** When using 25 mm (1 inch), 38 mm (1-1/2 inch), or occasionally 51 mm (2 inch) height-of-cut, move the skids and gage wheels to the highest position.

## Wing Mower Decks

To adjust the height of cut on the wing mower decks, add or remove an equal number of spacers from the caster forks, position the caster-wheel axles in the high or low height-of-cut holes in the caster forks, and secure the pivot arms to the selected height-of-cut bracket holes.

1. Position the caster-wheel axles in the same holes in all of the caster forks (Figure 21 and Figure 23).
2. Remove the tensioning cap from the spindle shaft and slide the spindle out of the caster arm (Figure 21).

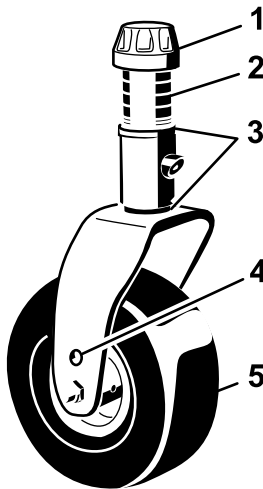

G008866

g008866

Figure 21

1. Tensioning cap
2. Spacers
3. Shims
4. Top axle-mounting hole
5. Caster wheel

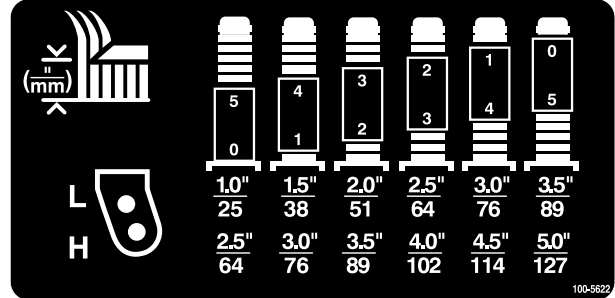

100-5622

decal100-5622nc

Figure 22

4. Push the caster spindle through the front caster arm.
5. Install the shims (as they were originally installed) and the remaining spacers onto the spindle shaft.
6. Remove the hairpin cotter and clevis pins from the caster-pivot arms (Figure 23).
7. Rotate the tension rod to raise or lower the pivot arm until the holes are aligned with the selected height-of-cut bracket holes in the mower-deck frame (Figure 23 and Figure 24).

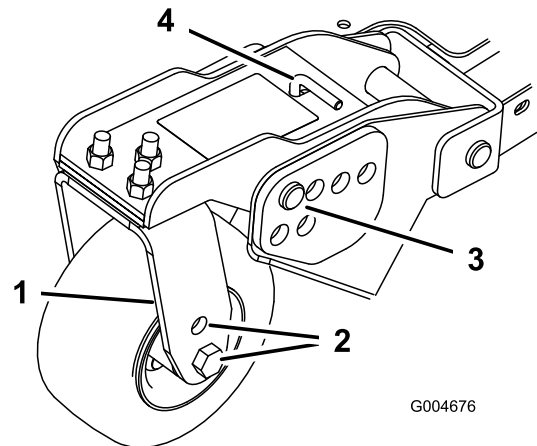

G004676

g004676

Figure 23

1. Caster-pivot arm
2. Axle-mounting holes
3. Clevis pin and hairpin cotter
4. Tension rod

3. Install 2 shims onto the spindle shaft as they were originally installed.

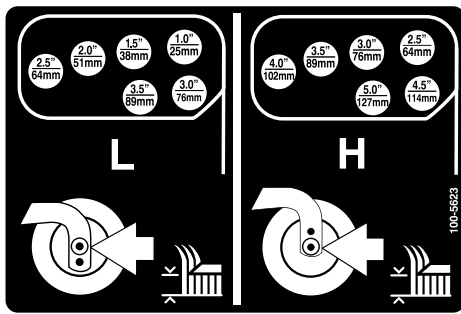

Figure 24

decal100-5623nc

8. Insert the clevis pins and install the hairpin cotters.
9. Rotate the tension rod counterclockwise (finger tight) to put tension on adjustment.

## Adjusting the Skids

Mount the skids in the lower position when operating at heights of cut greater than 64 mm (2-1/2 inches) and in the higher position when operating at heights of cut lower than 64 mm (2-1/2 inches).

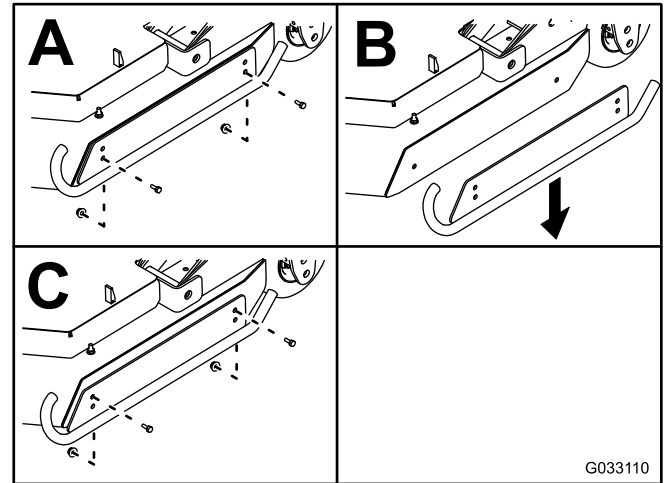

Figure 25

G033110

## Adjusting the Mower-Deck Rollers

The mower-deck rollers should be mounted in the lower position when operating at a height-of-cut greater than 64 mm (2-1/2 inches) and in the higher position when operating at a height-of-cut lower than 64 mm (2-1/2 inches).

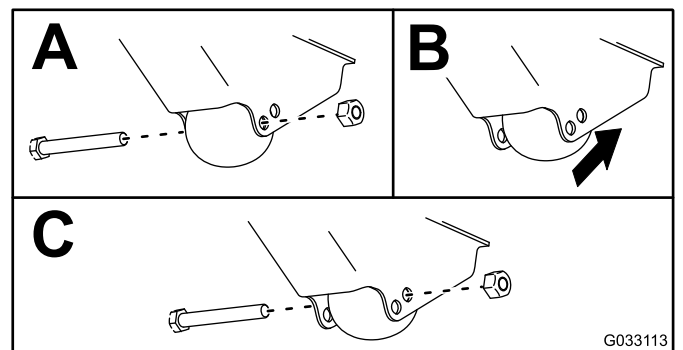

Figure 26

G033113

## Adjusting the Blade

To ensure proper operation of the mower deck, there must be a 10 to 16 mm (0.38 to 0.62 inch) clearance between the tips of the side and center mower-deck blades (Figure 27).

1. Raise mower deck so the blades are visible and block the center deck section so it cannot fall accidentally.

**Note:** The wing decks must be horizontal to the center mower deck.

2. Rotate a center and adjoining side blade so the blade tips are aligned. Measure the distance between the blade tips (Figure 27).

**Note:** The distance should be approximately 10 to 16 mm (0.38 to 0.62 inch)

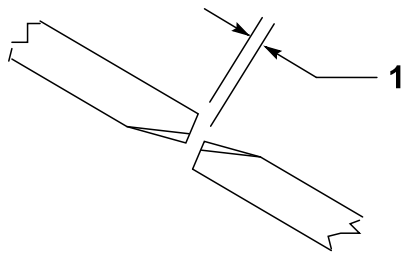

Figure 27

g223264

1. Clearance of 0.38 to 0.62 inches (10-16mm)
3. To adjust distance, locate adjuster bolt on rear pivot link of the mower deck (Figure 28).
4. Loosen the jam nut on the adjuster bolt.
5. Loosen or tighten the adjuster bolts until you attain a 10 to 16 mm (0.38 to 0.62 inch) clearance, then tighten the jam nut.
6. Repeat the procedure on the opposite side of the mower deck.

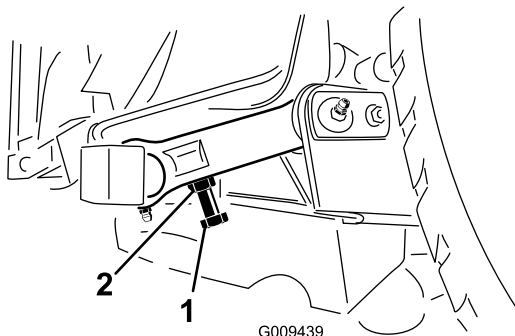

Figure 28

g009439

1. Adjuster bolt
2. Jam nut

## Correcting a Mismatch Between the Mower Decks

Due to differences in grass conditions and the counterbalance setting of the traction unit, a sample area of grass should be cut and the appearance checked before formal cutting is started.

1. Set all mower decks to the desired height of cut; refer to [Adjusting the Height of Cut \(page 26\)](#).
2. Check and adjust the air pressure in the front and rear tire of the machine to 172 to 207 kPa (25 to 30 psi).
3. Check and adjust the air pressure in all of the caster tires for the mower deck to 345 kPa (50 psi).
4. Check the charge and counterbalance pressures with the engine at HIGH IDLE, using hydraulic-test ports.

**Note:** Adjust the counterbalance to 2241 kPa (325 psi).

5. Check for bent blades; refer to [Checking for a Bent Blade \(page 83\)](#).
6. Cut grass in a test area to determine if all mower decks are cutting at the same height.
7. If mower-deck adjustments are still needed, find a flat surface using a 2 m (6 ft) or a longer straight edge.
8. To ease measuring the blade plane, raise the height-of-cut to 7.6 to 10.1 cm (3 to 4 inches); refer to [Adjusting the Height of Cut \(page 26\)](#).
9. Lower the mower decks onto a flat surface and remove the covers from the top of the mower decks.
10. Loosen the flange nut, securing the idler pulley, to release the belt tension on each mower deck.

## Setting Up the Center Mower Deck

**Note:** It is best to use the Toro tool (Part No. 121-3874) to tighten the tensioning cap.

1. Rotate the blade on each spindle until the ends face forward and backward.
2. Measure from the floor to the front tip of the cutting edge.
3. Adjust the shims (3 mm or 1/8 inch) on the front caster fork(s) to match the height-of-cut decal (Figure 29); refer to [Adjusting the Height of Cut](#) (page 26).

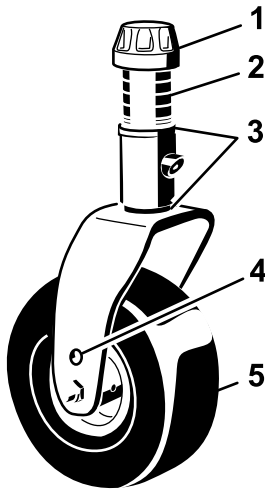

**Figure 29**

- |                   |                           |
|-------------------|---------------------------|
| 1. Tensioning cap | 4. Top axle-mounting hole |
| 2. Spacers        | 5. Caster wheel           |
| 3. Shims          |                           |

## Setting Up the Side Mower Decks

1. Rotate the blade of each spindle until the ends face forward and backward.
2. Measure from the floor to the front tip of the cutting edge.
3. Adjust the shims (3 mm or 1/8 inch) on front caster arm(s) to match the height-of-cut decal (Figure 30).

**Note:** For the outside blade spindle only, refer to [Adjusting the Mower-Deck Pitch](#) (page 81).

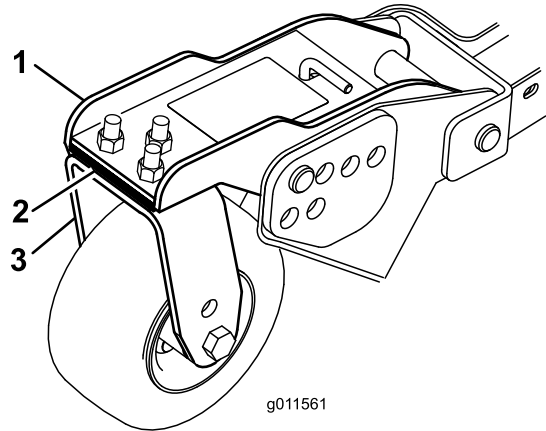

**Figure 30**

- |                     |                      |
|---------------------|----------------------|
| 1. Front caster arm | 3. Front caster fork |
| 2. Shims            |                      |

## Matching the Height of Cut Between Mower Decks

1. Position the blade side to side on the outside spindle of both side mower decks.

**Note:** Measure from the floor to the tip of the cutting edge on both units and compare. These numbers should be within 3 mm (1/8 inch) of each other. Make no adjustment at this time.

2. Position the blade side to side on the inside spindle of the side mower deck and corresponding outside spindle of the front mower deck.

**Note:** Measure from the floor to the tip of the cutting edge on the inside edge of side mower deck to the corresponding outside edge of front mower deck and compare. The side mower-deck measurement should be within 3 mm (1/8 inch) of the front mower deck.

**Note:** All 3 mower deck caster wheels should remain on the ground with counterbalance applied.

**Note:** If adjustments need to be made to match the cut between the front and side mower decks,

make the adjustments to the **side mower decks only**.

3. If the inside edge of the side mower deck is too high relative to the outside edge of the front mower deck, remove a shim from the bottom of the front, inside caster arm on the side mower deck (Figure 30).

**Note:** Check the measurements between the outside edges of both side mower decks and the inside edge of the side mower deck to the outside edge of the front mower deck again.

4. If the inside edge is still too high, remove an additional shim from the bottom of front, inside caster arm of the side mower deck **and** a shim from the front, outside caster arm of the side mower deck.
5. If the inside edge of the side mower deck is too low relative to the outside edge of the front mower deck, add a shim to the bottom of the front, inside caster arm on the side mower deck.

**Note:** Check the measurement between the outside edges of both side mower decks and the inside edge of the side mower deck to the outside edge of front mower deck again.

6. If the inside edge is still too low, add an additional shim to the bottom of front, inside caster arm of the side mower deck **and** add a shim to the front, outside caster arm of the side mower deck.
7. When the cutting height matches at the edges of front and side mower decks, verify that the side mower-deck pitch is still 8 to 11 mm (5/16 to 7/16 inch).

**Note:** Adjust as necessary.

## Checking the Safety-Interlock Switches

**Service Interval:** Before each use or daily

The machine has interlock switches in the electrical system. These switches disengage either the traction unit or the PTO whenever you leave the seat. If you disengage the PTO and engage the parking brake before you leave the seat, the engine continues to run.

1. Drive the machine slowly to a large, open area. Lower the mower deck, shut off the engine, and apply the parking brake.
2. Sit on the seat and press the traction pedal. Try to start the engine. The engine should not start. If the engine starts, there is a malfunction in the interlock system that should be corrected before beginning operation.
3. Sit on the seat, start the engine, and engage the PTO. While sitting in the seat with the PTO engaged, rise from the seat. The PTO should disengage after a slight delay. If the PTO engages, there is a malfunction in the interlock system that should be corrected before beginning operation.
4. Sit on the seat, engage the parking brake and start the engine. Move the traction pedal out of the NEUTRAL position. The InfoCenter should display "traction not allowed" and the machine should not move. If the engine does move, there is a malfunction in the interlock system that should be corrected before beginning operation.

# Using the InfoCenter Control

The InfoCenter LCD display shows information about your machine, such as the operating status and various diagnostics (Figure 31). There is a splash screen and a main information screen of the InfoCenter. You can switch between the splash and main information screens at any time by pressing any InfoCenter button and then selecting the appropriate directional arrow.

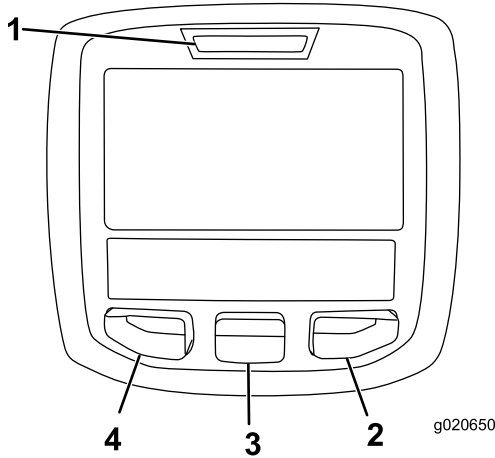

Figure 31

- 1. Indicator light
- 2. Right button
- 3. Middle button
- 4. Left button















- Left Button, Menu Access/Back Button—press this button to access the InfoCenter menus. You can use it to exit any menu that you are currently using.
- Middle Button—use this button to scroll down menus.
- Right Button—use this button to open a menu where a right arrow indicates additional content.
- Beeper—activated when lowering the decks or for advisories and faults.

**Note:** The purpose of each button may change depending on what is required at the time. Each button is labeled with an icon displaying its current function.







## InfoCenter Icon Description

	Indicates when scheduled service should be performed
	Engine rpm/status—indicates the engine rpm
	Hour meter
	Info icon
	Sets the maximum traction speed
	Fast
	Slow
	Fan Reversal—indicates when the fan is reversed
	Fuel level
	Stationary regeneration required
	Air intake heater is active
	Raise the left deck
	Raise the center deck
	Raise the right deck
	Operator must sit in seat
	Parking Brake Indicator—indicates when the parking brake is on
	Identifies the range as High
	Neutral
	Identifies the range as Low
	Coolant Temperature—indicates the engine coolant temperature in either °C or °F
	Temperature (hot)
	Traction or Traction Pedal

## InfoCenter Icon Description (cont'd.)

	Denied or not allowed
	Engine Start
	PTO—indicates that the PTO is on
	Stop or shutdown
	Engine
	Key switch
	Indicates when the mower decks are being lowered
	Indicates when the mower decks are being raised
	PIN code
	Hydraulic-Fluid Temperature—indicates the hydraulic-fluid temperature
CAN	CAN bus
	InfoCenter
Bad	Bad or failed
Ctr	Center
Rht	Right
Left	Left
	Bulb
OUT	Output of TEC controller or control wire in harness
HI	High: over-allowed range
LO	Low: under-allowed range
HI, LO	Out of range
	Switch
	Operator must release the switch

## InfoCenter Icon Description (cont'd.)

	Operator should change to the indicated state
Symbols are often combined to form sentences. Some examples are shown below	
	Operator should put the machine in neutral
	Engine start denied
	Engine shutdown
	Engine coolant is too hot
	Hydraulic fluid is too hot
	Sit down or engage the parking brake

## Using the Menu

To access the InfoCenter menu system, press the menu access button while at the main screen. This brings you to the main menu. Refer to the following tables for a synopsis of the options available from the menus:

Main Menu	
Menu Item	Description
Faults	The Faults menu contains a list of the recent machine faults. Refer to the Service Manual or your Authorized Toro Distributor for more information on the Faults menu and the information contained there.
Service	The Service menu contains information on the machine such as hours of use and other similar numbers.
Diagnostics	The Diagnostics menu displays the state of each machine switch, sensor and control output. You can use this to troubleshoot certain issues as it will quickly tell you which machine controls are on and which are off.



<b>Main Menu</b>	
Settings	The Settings menu allows you to customize and modify configuration variables on the InfoCenter display.
About	The About menu lists the model number, serial number, and software version of your machine.

<b>Service</b>	
<b>Menu Item</b>	<b>Description</b>
Hours	Lists the total number of hours that the machine, engine and fan have been on, as well as the number of hours that the machine has been transported and overheated
Counts	Lists the number of preheats and starts that the machine has experienced

<b>Diagnostics</b>	
<b>Menu Item</b>	<b>Description</b>
Engine Run	Refer to the Service Manual or your Authorized Toro Distributor for more information on the Engine Run menu and the information contained there.
Glowplugs	Indicates if the following items are active: Key start, timeout limited, and glowplugs
Fan	Indicates if the fan is active in the following instances: Engine high temp, oil high temp, engine or hydraulic high temp, and fan on

<b>Settings</b>	
<b>Menu Item</b>	<b>Description</b>
Units	Controls the units used on the InfoCenter; the menu choices are English or Metric
Language	Controls the language used on the InfoCenter*
LCD Backlight	Controls the brightness of the LCD display
LCD Contrast	Controls the contrast of the LCD display
Protected Menus	Allows a person authorized by your company with the PIN code to access protected menus.
Auto Idle	Controls the amount of time allowed before idling the engine when the machine is not in use
Mow Speed	Controls the maximum speed while in mow (low range)
Trans Speed	Controls the maximum speed while in transport (high range)
Smart Power	Smart Power prevents bogging down in heavy turf by automatically controlling the machine speed and optimizing cutting performance.

\*Only "operator-faced" text is translated. Faults, Service, and Diagnostics screens are "service-faced." Titles are in the selected language, but menu items are in English.

<b>About</b>	
<b>Menu Item</b>	<b>Description</b>
Model	Lists the model number of the machine
SN	Lists the serial number of the machine
Machine Controller Revision	Lists the software revision of the master controller
InfoCenter Revision	Lists the software revision of the InfoCenter
CAN Bus	Lists the machine communication bus status

## Protected Menu

There are 4 operating configuration settings that are adjustable within the Settings Menu of the InfoCenter: auto idle time delay, maximum mowing ground speed, maximum transport ground speed, and Smart Power. These settings are in the Protected Menu.

## Accessing Protected Menus

**Note:** The factory default PIN code for your machine is either 0000 or 1234.

If you changed the PIN code and forgot the code, contact your authorized Toro distributor for assistance.

1. From the MAIN MENU, use the center button to scroll down to the SETTINGS MENU and press the right button (Figure 32).

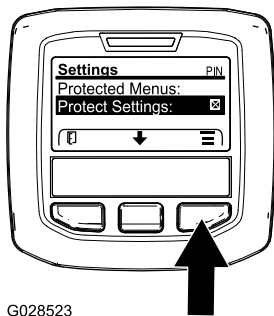

Figure 32

g028523

2. In the SETTINGS MENU, use the center button to scroll down to the PROTECTED MENU and press the right button (Figure 33A).

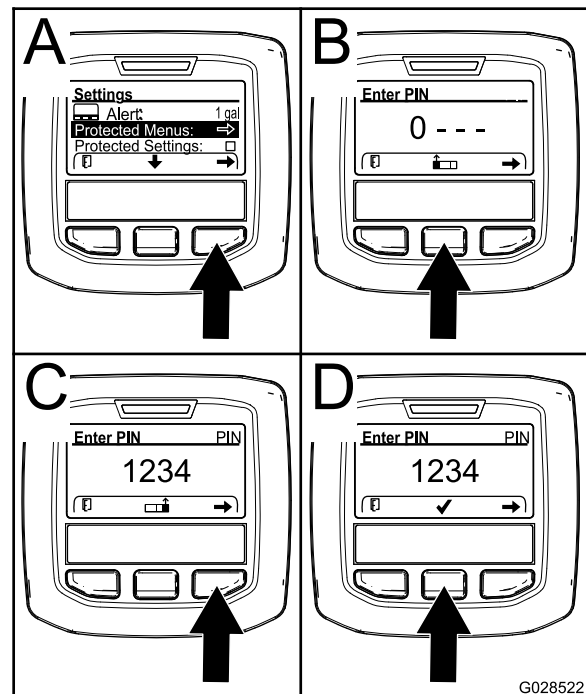

Figure 33

g028522

3. To enter the PIN code, press the center button until the correct first digit appears, then press the right button to move on to the next digit (Figure 33B and Figure 33C). Repeat this step until the last digit is entered and press the right button once more.
4. Press the middle button to enter the PIN code (Figure 33D).

Wait until the red indicator light of the InfoCenter illuminates.

**Note:** If the InfoCenter accepts the PIN code and the protected menu is unlocked, the word "PIN" displays in the upper right corner of the screen.

**Note:** Rotate the key switch to the OFF position and then to the ON position locks the protected menu.

You can view and change the settings in the Protected Menu. Once you access the Protected Menu, scroll down to Protect Settings option. Use the right button to change the setting. Setting the Protect Settings to OFF allows you to view and change the settings in the Protected Menu without entering the PIN code. Setting the Protect Settings to ON hides the protected options and requires you to enter the PIN code to change the setting in the Protected Menu. After you set the PIN code, rotate the key switch OFF and back to the ON position to enable and save this feature.

## Setting the Auto Idle

1. In the Settings Menu, scroll down to Auto Idle.

2. Press the right button to change the auto idle time between Off, 8S, 10S, 15S, 20S, and 30S.

## Setting the Maximum Allowed Mow Speed

1. In the Settings Menu, scroll down to Mow Speed and press the right button.
2. Use the right button to increase the max full mow speed (50%, 75%, or 100%).
3. Use the center button to decrease the max full mow speed (50%, 75%, or 100%).
4. Press the left button to exit.

## Setting the Maximum Allowed Transport Speed

1. In the Settings Menu, scroll down to Transport Speed and press the right button.
2. Use the right button to increase the max transport speed (50%, 75%, or 100%).
3. Use the center button to decrease the max transport speed (50%, 75%, or 100%).
4. Press the left button to exit.

When finished with the Protected Menu, press the left button to exit to the Main Menu, then press the left button to exit to the Run Menu.

# ***During Operation***

## **During Operation Safety**

### **General Safety**

- The owner/operator can prevent and is responsible for accidents that may cause personal injury or property damage.
- Wear appropriate clothing, including eye protection; long pants; substantial, slip-resistant footwear; and hearing protection. Tie back long hair and do not wear loose jewelry.
- Do not operate the machine while ill, tired, or under the influence of alcohol or drugs.
- Never carry passengers on the machine and keep bystanders and pets away from the machine during operation.
- Operate the machine only in good visibility to avoid holes or hidden hazards.
- Before you start the engine, ensure that all drives are in neutral, the parking brake is engaged, and you are in the operating position.
- Keep your hands and feet away from rotating parts. Keep clear of the discharge opening at all times.
- Look behind and down before backing up to be sure of a clear path.
- Use care when approaching blind corners, shrubs, trees, or other objects that may obscure your vision.
- Stop the blades whenever you are not mowing.
- Stop the machine, remove the key, and wait for all moving parts to stop before inspecting the attachment after striking an object or if there is an abnormal vibration in the machine. Make all necessary repairs before resuming operation.
- Slow down and use caution when making turns and crossing roads and sidewalks with the machine. Always yield the right-of-way.
- Disengage the drive to the cutting unit, shut off the engine, remove the key, and wait for all moving parts to stop before adjusting the height of cut (unless you can adjust it from the operating position).
- Never run an engine in an area where exhaust gasses are enclosed.
- Never leave a running machine unattended.
- Before leaving the operating position (including to empty the catchers or to unclog the chute), do the following:
  - Park the machine on level ground.

- Disengage the power takeoff and lower the attachments.
- Engage the parking brake.
- Shut off the engine and remove the key.
- Wait for all moving parts to stop.
- Do not operate the machine when there is the risk of lightning.
- Do not use the machine as a towing vehicle.
- Use accessories, attachments, and replacement parts approved by The Toro® Company only.

## Rollover Protection System (ROPS) Safety

- **Do not** remove the ROPS from the machine.
- Ensure that the seat belt is attached and that you can release it quickly in an emergency.
- Check carefully for overhead obstructions and do not contact them.
- Keep the ROPS in safe operating condition by thoroughly inspecting it periodically for damage and keeping all the mounting fasteners tight.
- Replace a damaged ROPS components. Do not repair or alter them.

### Machines with Cabs

- The ROPS is an integral and effective safety device.
- A cab installed by Toro is a roll bar.
- Always wear your seat belt.

### Machines with a Foldable Roll Bar

- Always use the seat belt with the roll bar in the raised position.
- The ROPS is an integral safety device. Keep a folding roll bar in the raised and locked position, and use the seat belt when operating the machine with the roll bar in the raised position.
- Lower a folding roll bar temporarily only when necessary. Do not wear the seat belt when the roll bar is folded down.
- Be aware that there is no rollover protection when a folded roll bar is in the down position.
- Check the area that you will be mowing and never fold down a folding roll bar in areas where there are slopes, drop-offs, or water.

## Slope Safety

Slopes are a major factor related to loss of control and rollover accidents, which can result in severe injury or death. You are responsible for safe slope operation. Operating the machine on any slope requires extra caution.

- Evaluate the site conditions to determine if the slope is safe for machine operation including surveying the site. Always use common sense and good judgment when performing this survey.
- Review the slope instructions listed below for operating the machine on slopes and review the conditions in which you would operate the machine to determine whether you can operate it in the conditions on that day and at that site. Changes in the terrain can result in a change in slope operation for the machine.
- Avoid starting, stopping, or turning the machine on slopes. Avoid making sudden changes in speed or direction. Make turns slowly and gradually.
- Do not operate a machine under any conditions where traction, steering, or stability is in question.
- Remove or mark obstructions such as ditches, holes, ruts, bumps, rocks, or other hidden hazards. Tall grass can hide obstructions. Uneven terrain could overturn the machine.
- Be aware that operating the machine on wet grass, across slopes, or downhill may cause the machine to lose traction. Loss of traction to the drive wheels may result in sliding and a loss of braking and steering.
- Use extreme caution when operating the machine near drop-offs, ditches, embankments, water hazards, or other hazards. The machine could suddenly roll over if a wheel goes over the edge or the edge caves in. Establish a safety area between the machine and any hazard.
- Identify hazards at the base of the slope. If there are hazards, mow the slope with a pedestrian-controlled machine.
- If possible, keep the cutting unit(s) lowered to the ground while operating on slopes. Raising the cutting unit(s) while operating on slopes can cause the machine to become unstable.
- Use extreme caution while operating the machine with grass-collection systems or other attachments. These can change the stability of the machine and cause a loss of control.

## Starting the Engine

**Important:** The fuel system automatically bleeds itself when any of the following situations occur:

- Initial start up of a new machine.
  - The engine has ceased running due to lack of fuel.
  - Maintenance has been performed upon the fuel system components.
1. Remove your foot from the traction pedal and ensure that it is in neutral. Ensure that the parking brake is set.

2. Move the engine-speed switch to the LOW-IDLE position.
3. Turn the ignition key to the RUN position.

**Note:** The glow-plug indicator illuminates.

4. When the glow indicator dims, turn the ignition key to the START position. Release the key immediately when the engine starts and allow it to return to the RUN position.

**Important:** Do not run the starter motor more than 30 seconds at a time or premature starter failure may result. If the engine fails to start after 30 seconds, turn the key to the OFF position, check the controls and procedures, wait 30 additional seconds, and repeat the starting procedure.

5. Allow engine to warm up at mid speed (without load), then move the throttle control to the desired position.

**Important:** Allow engine to idle for 5 minutes before shutting it off after a full-load operation. Failure to do so may lead to turbo-charger trouble.

## Shutting Off the Engine

**Important:** Allow the engine to idle for 5 minutes before shutting it off after a full-load operation. This allows the turbocharger to cool down before shutting off the engine. Failure to do so may lead to turbocharger trouble.

**Note:** Lower the mower decks to the ground whenever machine is parked. This relieves the hydraulic load from the system, prevents wear on system parts, and also prevents accidental lowering of the mower decks.

1. Move the throttle control backward to the SLOW position.
2. Move the PTO switch to the OFF position.
3. Engage the parking brake.
4. Rotate the ignition key to the OFF position.
5. Remove the key from the switch to prevent accidental starting.

## Understanding Smart Power® Traction

With the Smart Power® function, you do not have to listen to the engine speed in heavy conditions. This function prevents bogging down in heavy turf by automatically controlling the machine speed and optimizing cutting performance. You can set a comfortable maximum ground speed and mow without

having to manually reduce the traction speed when you mow in heavy conditions.

## Performing a Fan-Reverse Operation

The machine-fan speed is controlled by the hydraulic-fluid temperature and engine-coolant temperature. When the hydraulic fluid or coolant reaches a certain temperature, a reverse fan cycle is automatically initiated. This cycle blows debris off the rear screen and lowers the engine-coolant and hydraulic-fluid temperatures.

You can complete a manually-initiated reverse cycle by simultaneously pressing the right and left buttons on the InfoCenter. It is recommended that you manually reverse the fan before you leave the work area or enter the maintenance or storage area.

## Understanding Auto Idle

The machine is equipped with auto idle, which automatically idles the engine when all the following functions are not used for a pre-determined time as previously set in the InfoCenter.

- The traction pedal is returned to the NEUTRAL position.
- The PTO is disengaged.
- None of the lift switches are activated.

When you initiate any of the above functions, the machine automatically returns to the previous throttle position.

## Using the Cruise Control

The cruise-control switch locks in the pedal position to maintain the desired ground speed. Pressing the rear of the switch turns cruise control off, the middle position of the switch enables the cruise-control function, and the front of the switch sets the desired ground speed.

**Note:** Pressing the brake pedal or moving the traction pedal into the reverse position, for 1 second, shuts off the cruise control.

## Diesel Particulate Filter Regeneration

The diesel particulate filter (DPF) is part of the exhaust system. The diesel-oxidation catalyst of the DPF reduces harmful gasses and the soot filter removes soot from the engine exhaust.

The DPF regeneration process uses heat from the engine exhaust to incinerate the soot accumulated on the soot filter, converting the soot to ash, and clears the channels of the soot filter so that filtered engine exhaust flows out the DPF.

The engine computer monitors the accumulation of soot by measuring the back pressure in the DPF. If the back pressure is too high, soot is not incinerating in the soot filter through normal engine operation. To keep the DPF clear of soot, remember the following:

- Passive regeneration occurs continuously while the engine is running—run the engine at full engine speed when possible to promote DPF regeneration.
- If the back pressure in the DPF is too high or a reset regeneration has not occurred for 100 hours, the engine computer signals you through the InfoCenter when reset regeneration is running.
- Allow the reset regeneration process to complete before shutting off the engine.

### Engine Warning Messages—Soot Accumulation

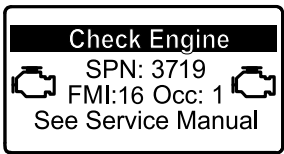
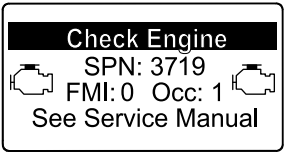
Indication Level	Fault Code	Engine Power Rating	Recommended Action
Level 1: Engine Warning	 <p><b>Figure 34</b> Check Engine SPN 3719, FMI 16</p>	The computer de-rates the engine power to 85%.	Perform a parked regeneration as soon as possible; refer to <a href="#">Parked or Recovery Regeneration (page 46)</a> .
Level 2: Engine Warning	 <p><b>Figure 35</b> Check Engine SPN 3719, FMI 0</p>	The computer de-rates the engine power to 50%.	Perform a recovery regeneration as soon as possible; refer to <a href="#">Parked or Recovery Regeneration (page 46)</a> .

Operate and maintain your machine with the function of the DPF in mind. Engine load at high idle (full throttle) engine speed generally produces adequate exhaust temperature for DPF regeneration.

**Important:** Minimize the amount of time that you idle the engine or operate the engine at low-engine speed to help reduce the accumulation of soot in the soot filter.



### DPF Soot Accumulation

- Over time, the diesel particulate filter accumulates soot in the soot filter. The computer for the engine monitors the soot level in the DPF.
- When enough soot accumulates, the computer informs you that it is time to regenerate the DPF.
- DPF regeneration is a process that heats the DPF to convert the soot to ash.
- In addition to the warning messages, the computer reduces the power produced by the engine at different soot-accumulation levels.

## DPF Ash Accumulation

- The lighter ash is discharged through the exhaust system; the heavier ash collects in the soot filter.
- Ash is a residue of the regeneration process. Over time, the diesel particulate filter accumulates ash that does not discharge with the engine exhaust.
- The computer for the engine calculates the amount of ash accumulated in the DPF.
- When enough ash accumulates, the engine computer sends information to the InfoCenter in the form of an engine fault to indicate the accumulation of ash in the DPF.
- The fault messages indicate that it is time to service the DPF.
- In addition to the warnings, the computer reduces the power produced by the engine at different ash-accumulation levels.

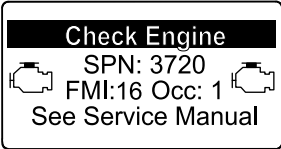
### InfoCenter Advisory and Engine Warning Messages—Ash Accumulation



Indication Level	Fault Code	Engine Speed Reduction	Engine Power Rating	Recommended Action
Level 1: Engine Warning	 <p><b>Check Engine</b> SPN: 3720 FMI:16 Occ: 1 See Service Manual</p> <p><small>g213863</small></p> <p><b>Figure 36</b> Check Engine SPN 3720, FMI 16</p>	None	The computer de-rates the engine power to 85%.	Service the DPF; refer to <a href="#">Servicing the Diesel-Oxidation Catalyst (DOC) and the Soot Filter (page 66)</a>
Level 2: Engine Warning	 <p><b>Check Engine</b> SPN: 3720 FMI:16 Occ: 1 See Service Manual</p> <p><small>g213863</small></p> <p><b>Figure 37</b> Check Engine SPN 3720, FMI 16</p>	None	The computer de-rates the engine power to 50%.	Service the DPF; refer to <a href="#">Servicing the Diesel-Oxidation Catalyst (DOC) and the Soot Filter (page 66)</a>
Level 3: Engine Warning	 <p><b>Check Engine</b> SPN: 3251 FMI: 0 Occ: 1 See Service Manual</p> <p><small>g214715</small></p> <p><b>Figure 38</b> Check Engine SPN 3251, FMI 0</p>	Engine speed at maximum torque + 200 rpm	The computer de-rates the engine power to 50%.	Service the DPF; refer to <a href="#">Servicing the Diesel-Oxidation Catalyst (DOC) and the Soot Filter (page 66)</a>

# Types of Diesel Particulate Filter Regeneration

## Types of diesel particulate filter regeneration that are performed while the machine is operating:

Type of Regeneration	Conditions that cause DPF regeneration	DPF description of operation
<b>Passive</b>	Occurs during normal operation of the machine at high-engine speed or high-engine load	<ul style="list-style-type: none"> <li>The InfoCenter does not display an icon indicating passive regeneration.</li> <li>During passive regeneration, the DPF processes high-heat exhaust gasses, oxidizing harmful emissions, and burning soot to ash.</li> </ul> Refer to <a href="#">Passive DPF Regeneration (page 43)</a> .
<b>Assist</b>	Occurs because of low-engine speed, low-engine load, or after the computer detects the DPF is becoming obstructed with soot	<ul style="list-style-type: none"> <li>The InfoCenter does not display an icon indicating assist regeneration.</li> <li>During assist regeneration, the engine computer adjusts the engine settings to raise the exhaust temperature.</li> </ul> Refer to <a href="#">Assist DPF Regeneration (page 44)</a> .
<b>Reset</b>	Occurs every 100 hours  Also occurs after assist regeneration only if the computer detects that assist regeneration did not sufficiently reduce the soot level	 <ul style="list-style-type: none"> <li>When the high exhaust-temperature icon is displayed in the InfoCenter, a regeneration is in progress.</li> <li>During reset regeneration, the engine computer adjusts the engine settings to raise the exhaust temperature.</li> </ul> Refer to <a href="#">Reset Regeneration (page 44)</a> .

## Types of diesel particulate filter regeneration that require you to park the machine:

Type of Regeneration	Conditions that cause DPF regeneration	DPF description of operation
<b>Parked</b>	Occurs because the computer detects back pressure in the DPF due to soot buildup  Also occurs because the operator initiates a parked regeneration  May occur because you set the InfoCenter to inhibit reset regeneration and continued operating the machine, adding more soot when the DPF already needs a reset regeneration  May result from using the incorrect fuel or engine oil	 <ul style="list-style-type: none"> <li>When the reset-standby/parked or recovery regeneration icon  or ADVISORY #188 displays in the InfoCenter, a regeneration is requested.</li> <li>Perform the parked regeneration as soon as possible to avoid needing a recovery regeneration.</li> <li>A parked regeneration requires 30 to 60 minutes to complete.</li> <li>You must have at least a 1/4 tank of fuel in the tank.</li> <li>You must park the machine to perform a parked regeneration.</li> </ul> Refer to <a href="#">Parked or Recovery Regeneration (page 46)</a> .



## Types of diesel particulate filter regeneration that require you to park the machine: (cont'd.)

Type of Regeneration	Conditions that cause DPF regeneration	DPF description of operation
Recovery	Occurs because the operator ignored requests for a parked regeneration and continued operating the machine, adding more soot to the DPF	<ul style="list-style-type: none"> <li>When the reset-standby/parked or recovery regeneration icon  or ADVISORY #190 displays in the InfoCenter, a recovery regeneration is requested.</li> <li>A recovery regeneration requires up to 3 hours to complete.</li> <li>You must have at least a 1/2 tank of fuel in the machine.</li> <li>You must park the machine to perform a recovery regeneration.</li> </ul> <p>Refer to <a href="#">Parked or Recovery Regeneration (page 46)</a>.</p>

## Accessing the DPF Regeneration Menus

### Accessing the DPF Regeneration Menus

1. Access the Service menu, press the center button to scroll down to the DPF REGENERATION option ([Figure 39](#)).

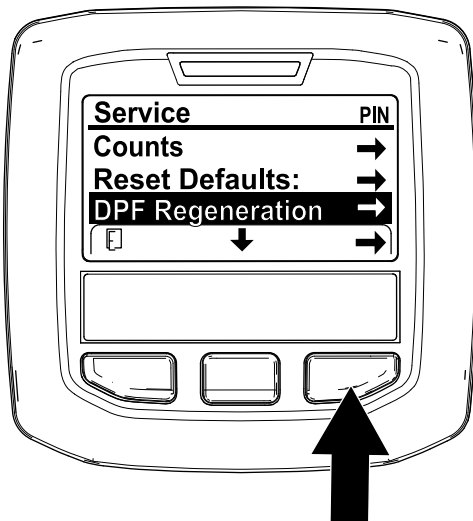

Figure 39

g227667

2. Press the right button to select the DPF Regeneration entry ([Figure 39](#)).

### Time Since Last Regeneration

Access the DPF Regeneration menu, press the center button to scroll down to the LAST REGEN field ([Figure 40](#)).

Use the LAST REGEN field to determine how many hours you have run the engine since the last reset, parked, or recovery regeneration.

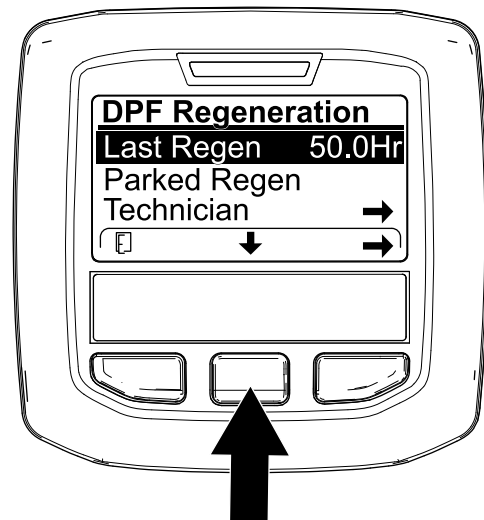

Figure 40

g224693

### Technician Menu

**Important:** For operating convenience, you may decide to perform a parked regeneration before the soot load reaches 100%, provided the engine has run more than 50 hours since the last successful reset, parked, or recovery regeneration.

Use the technician menu to view the current state of engine regeneration control and view the reported soot level.

Access the DPF Regeneration menu, press the center button to scroll down to the TECHNICIAN option, and

press the right button to select the Technician entry (Figure 41).

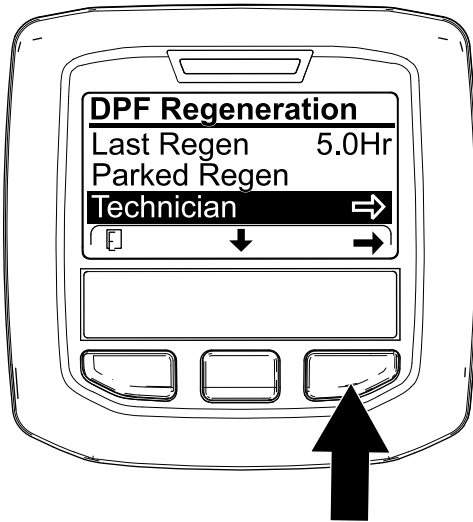

Figure 41

g227348

- Use the DPF operation table to understand the current state of DPF operation (Figure 42).

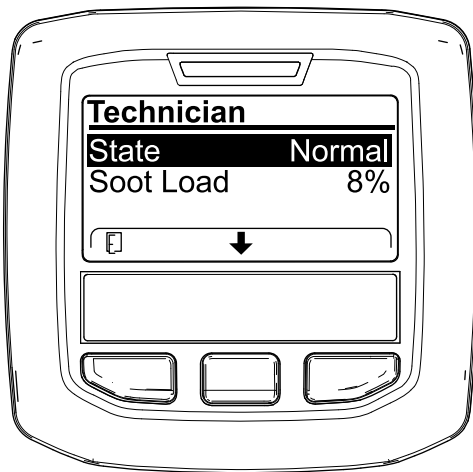

Figure 42

g227360

### DPF Operation Table

State	Description	
Normal	The DPF is in normal-operating mode—passive regeneration.	
Assist Regen	The engine computer is performing an assist regeneration.	
Reset Stby	The engine computer is trying to run a reset regeneration, but 1 of the following conditions prevents regeneration:	The regen inhibit setting is set to ON.
		The exhaust temperature is too low for regeneration.

### DPF Operation Table (cont'd.)

State	Description
Reset Regen	The engine computer is running a reset regeneration.
Parked Stby	The engine computer is requesting that you run a parked regeneration.
Parked Regen	You initiated a parked regeneration request and the engine computer is processing the regeneration.
Recov. Stby	The engine computer is requesting that you run a recovery regeneration.
Recov. Regen	You initiated a recovery regeneration request and the engine computer is processing the regeneration.

- View the soot load which is measured as the percentage of soot in the DPF (Figure 43); refer to the soot-load table.

**Note:** The soot load value varies as the machine is operated and DPF regeneration occurs.

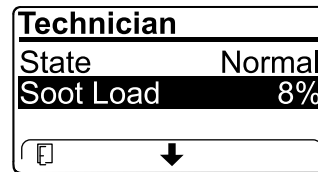

Figure 43

g227359

### Soot-Load Table

Important Soot Load Values	Regeneration State
0% to 5%	Minimum soot load range
78%	The engine computer performs an assist regeneration.
100%	The engine computer automatically requests a parked regeneration.
122%	The engine computer automatically requests a recovery regeneration.

### Passive DPF Regeneration

- Passive regeneration occurs as part of normal engine operation.
- While operating the machine, run the engine at full-engine speed and high load when possible to promote DPF regeneration.

## Assist DPF Regeneration

- The engine computer adjusts engine settings to raise the exhaust temperature.
- While operating the machine, run the engine at full engine speed and high load when possible to promote DPF regeneration.

## Reset Regeneration

### ⚠ CAUTION

The exhaust temperature is hot (approximately 600°C (1,112°F) during DPF regeneration. Hot exhaust gas can harm you or other people.

- Never operate the engine in an enclosed area.
- Make sure that there are no flammable materials around the exhaust system.
- Never touch a hot exhaust system component.
- Never stand near or around the exhaust pipe of the machine.

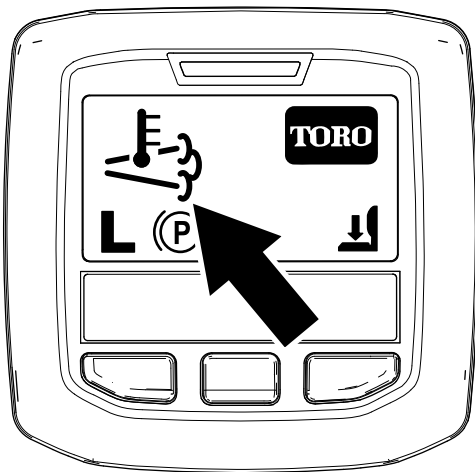



Figure 44

g224417

- The high exhaust-temperature icon  displays in the InfoCenter (Figure 44).
- The engine computer adjusts engine settings to raise the exhaust temperature.

**Important:** The high exhaust-temperature icon indicates that the exhaust temperature discharged from of your machine may be hotter than during regular operation.

- While operating the machine, run the engine at full engine speed and high load when possible to promote DPF regeneration.

- The icon displays in the InfoCenter while the reset regeneration is processing.
- Whenever possible, do not shut off the engine or reduce engine speed while the reset regeneration is processing.

**Important:** Whenever possible, allow the machine to complete the reset regeneration process before shutting off the engine.

## Periodic Reset Regeneration

If the engine has not completed a successful Reset, Parked, or Recovery regeneration in the previous 100 hours of engine operation, the engine computer will attempt to perform a reset regeneration.

## Setting the Inhibit Regen

### Reset Regeneration Only

**Note:** If you set the InfoCenter to inhibit regeneration, the InfoCenter displays ADVISORY #185 (Figure 45) every 15 minutes while the engine requests a reset regeneration.

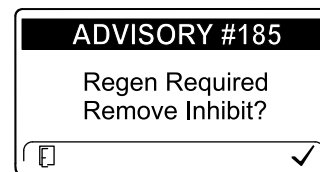

Figure 45

g224692

A reset regeneration produces the elevated engine exhaust. If you are operating the machine around trees, brush, tall grass, or other temperature-sensitive plants or materials, you can use the Inhibit Regen setting to prevent the engine computer from performing a reset regeneration.

**Important:** When you shut off the engine and start it again, the inhibit regen setting defaults to OFF.

1. Access the DPF Regeneration menu, press the center button to scroll down to the INHIBIT REGEN option, and press the right button to select the Inhibit Regen entry (Figure 46).

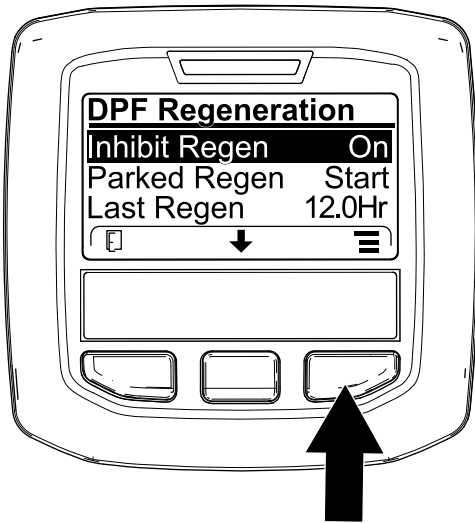

Figure 46

g227304

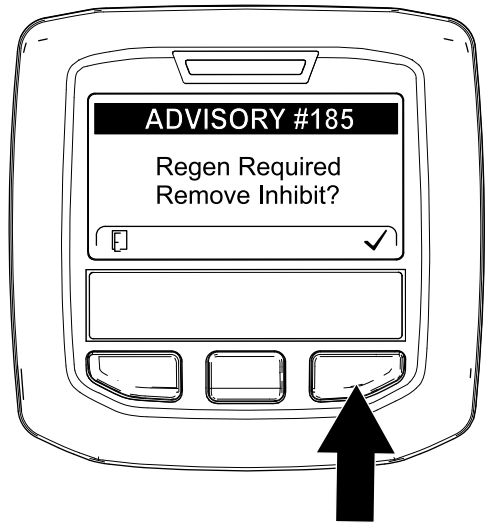

Figure 48

g224394

- Press the right button to change the inhibit regeneration setting from On to Off (Figure 46) or from Off to On (Figure 47).

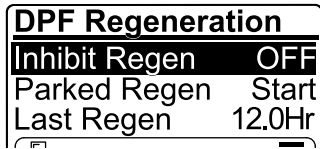

Figure 47

g224691

**Note:** If the engine exhaust temperature is too low, the InfoCenter displays ADVISORY #186 (Figure 49) to inform you to set the engine to full throttle (high idle).

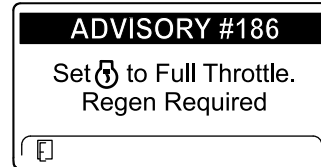



Figure 49

g224395

### Allowing a Reset Regeneration

The InfoCenter displays the high exhaust-temperature

icon  when the reset regeneration is in process.

**Note:** If INHIBIT REGEN is set to ON, the InfoCenter displays ADVISORY #185 (Figure 48). Press button 3 to set inhibit regeneration setting to OFF and continue with the reset regeneration.

**Note:** When the reset regeneration completes, the

high exhaust-temperature  disappears from the InfoCenter screen.

## Parked or Recovery Regeneration

- When the engine computer requests either a parked regeneration or a recovery regeneration, the regeneration request icon (Figure 50) displays in the InfoCenter.

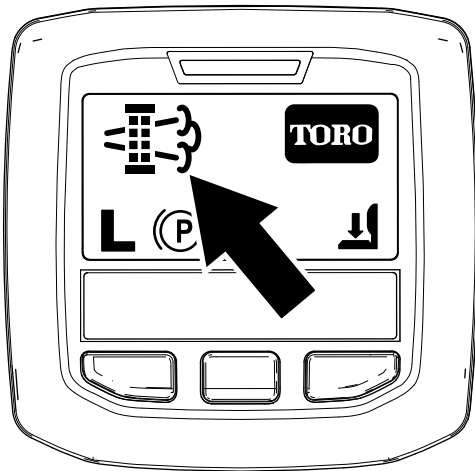

Figure 50

g224404

- The machine does not automatically perform a parked regeneration or a recovery regeneration, you must run the regeneration through the InfoCenter.

## Parked Regeneration Messages

When a parked regeneration is requested by the engine computer the following messages display in the InfoCenter:

- Engine warning SPN 3720, FMI 16 (Figure 51)

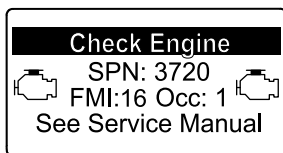

Figure 51

g213863

- Parked regeneration required ADVISORY #188 (Figure 52)

**Note:** Advisory #188 displays every 15 minutes.

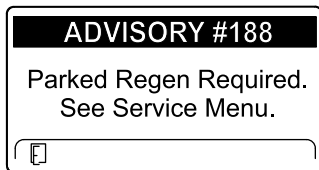

Figure 52

g224397

- If you do not perform a parked regeneration within 2 hours, the InfoCenter displays parked

regeneration required—power takeoff disabled ADVISORY #189 (Figure 53).

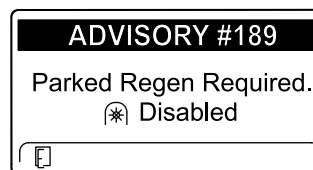

Figure 53

g224398

**Important:** Perform a parked regeneration to restore the PTO function; refer to [Preparing to Perform a Parked or Recovery Regeneration \(page 47\)](#) and [Performing a Parked or Recovery Regeneration \(page 47\)](#).

**Note:** The Home screen displays the PTO disabled icon (Figure 54).

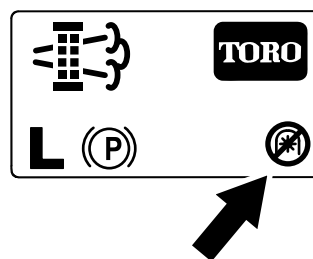

Figure 54

g224415

## Recovery Regeneration Messages

When a recovery regeneration is requested by the engine computer, the following messages display in the InfoCenter:

- Engine warning SPN 3719, FMI 0 (Figure 55)

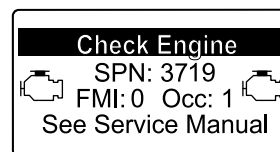

Figure 55

g213867

- Recovery regeneration required—power takeoff disabled ADVISORY #190 (Figure 56)

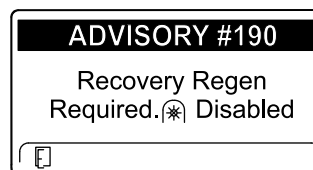

Figure 56

g224399

**Important:** Perform a recovery regeneration to restore the PTO function; refer to [Preparing to Perform a Parked or Recovery Regeneration \(page 47\)](#) and [Performing a Parked or Recovery Regeneration \(page 47\)](#).

**Note:** The Home screen displays the PTO disabled icon; refer to [Figure 54 in Parked Regeneration Messages \(page 46\)](#).

### DPF Status-Limitation

- If the engine computer requests a recovery regeneration or is processing a recovery regeneration and you scroll down to the PARKED REGEN option, parked regeneration locks and the lock icon ([Figure 57](#)) appears in the lower right corner of the InfoCenter.

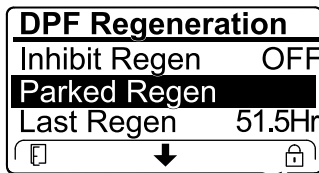

Figure 57

g224625

- If the engine computer has not requested a recovery regeneration and you scroll down to the RECOVERY REGEN option, the recovery regeneration locks and the lock icon ([Figure 58](#)) appears in the lower right corner of the InfoCenter.

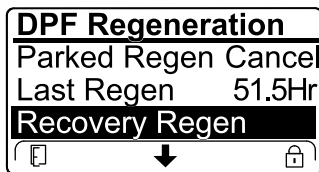

Figure 58

g224628

### Preparing to Perform a Parked or Recovery Regeneration

- Ensure that the machine has fuel in the tank for the type of regeneration you are performing:
  - Parked Regeneration:** Ensure that you have 1/4 tank of fuel before performing the parked regeneration.
  - Recovery Regeneration:** Ensure that you have 1/2 tank of fuel before performing the recovery regeneration.

- Move the machine outside to an area away from combustible materials.
- Park the machine on a level surface.
- Ensure that the traction control or motion-control levers are in the NEUTRAL position.
- If applicable, shut off the PTO, and lower the cutting units or accessories.
- Engage the parking brake.
- Set the throttle to the low IDLE position.

### Performing a Parked or Recovery Regeneration

#### ⚠ CAUTION

The exhaust temperature is hot (approximately 600°C (1,112°F) during DPF regeneration. Hot exhaust gas can harm you or other people.

- Never operate the engine in an enclosed area.
- Make sure that there are no flammable materials around the exhaust system.
- Never touch a hot exhaust system component.
- Never stand near or around the exhaust pipe of the machine.

**Important:** The computer of the machine cancels DPF regeneration if you increase the engine speed from low idle or release the parking brake.

- Access the DPF Regeneration menu, press the center button to scroll down to either the PARKED REGEN START option or the RECOVERY REGEN START option ([Figure 59](#)), and press the right button to select the start the regeneration ([Figure 59](#)).

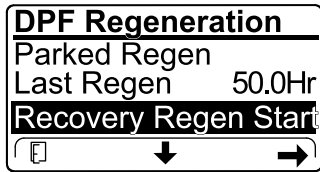
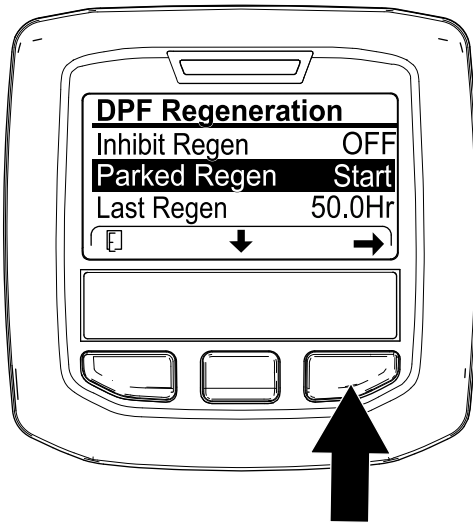

Figure 59

g224402

g224629

- At the DPF checklist screen, verify that the parking brake is engaged and that the engine speed is set to low idle (Figure 61).

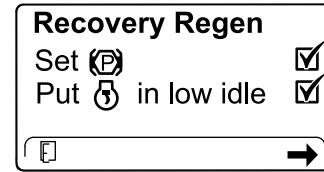
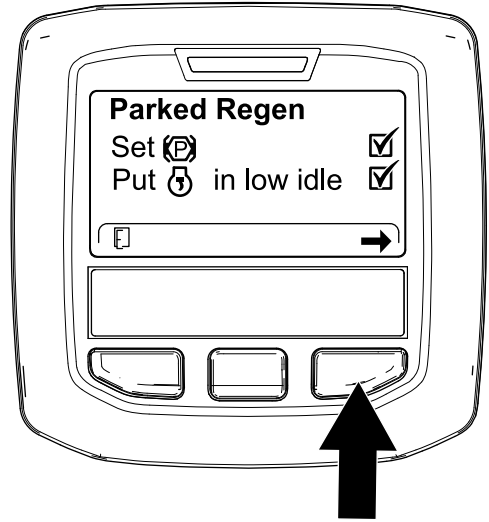

Figure 61

g224407

g227679

- At the VERIFY FUEL LEVEL screen, verify that you have 1/4 tank of fuel if you are performing the parked regeneration or 1/2 tank of fuel if you are performing the recovery regeneration, and press the right button to continue (Figure 60).

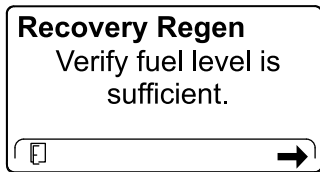
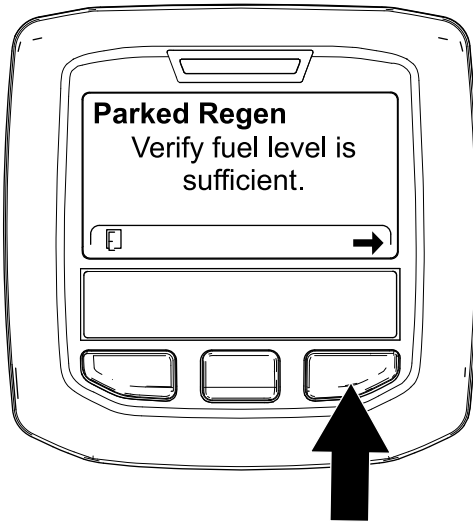

Figure 60

g224414

g227678

- At the INITIATE DPF REGEN screen, press the right button to continue (Figure 62).

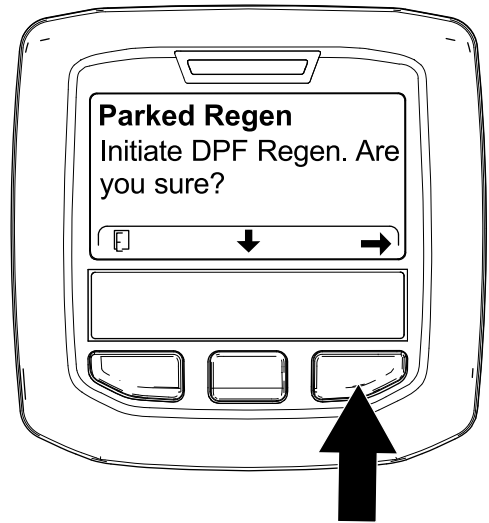

Figure 62

g224626

g224630



5. The InfoCenter displays the INITIATING DPF REGEN message (Figure 63).

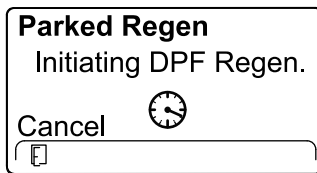

g224411

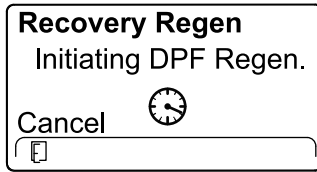

g227681

Figure 63

6. The InfoCenter displays the time to complete message (Figure 64).

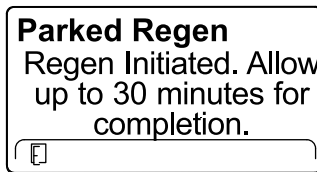

g224406

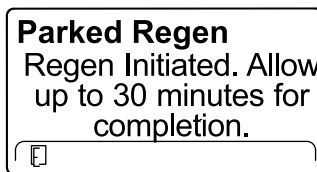

g224406

Figure 64

7. The engine computer checks the engine state and fault information. The InfoCenter may display the following messages found in the table that follows:

### Check Message and Corrective Action Table

<p><b>Corrective Action:</b> Exit the regeneration menu and run the machine until the time since last regeneration is greater than 50 hours; refer to <a href="#">Time Since Last Regeneration (page 42)</a>.</p>	
<p><b>Corrective Action:</b> Troubleshoot the engine fault and retry DPF regeneration.</p>	

### Check Message and Corrective Action Table (cont'd.)

<p><b>Corrective Action:</b> Start and run the engine.</p>	
<p><b>Corrective Action:</b> Run the engine to warm the coolant temperature to 60°C (140°F).</p>	
<p><b>Corrective Action:</b> Change the engine speed to low idle.</p>	
<p><b>Corrective Action:</b> Troubleshoot the engine computer condition and retry DPF regeneration.</p>	

8. The InfoCenter displays the home screen and the regeneration acknowledge icon (Figure 65) appears in the lower right corner of the screen as the regeneration processes.

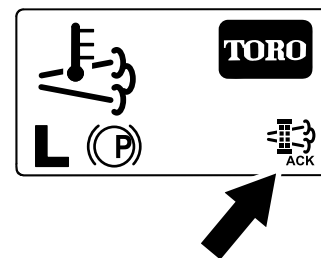

Figure 65

g224403

**Note:** While the DPF regeneration runs, the InfoCenter displays the high

exhaust-temperature icon

9. When the engine computer completes a parked or recovery regeneration, the InfoCenter



displays ADVISORY #183 (Figure 66). Press the left button to exit to the home screen.

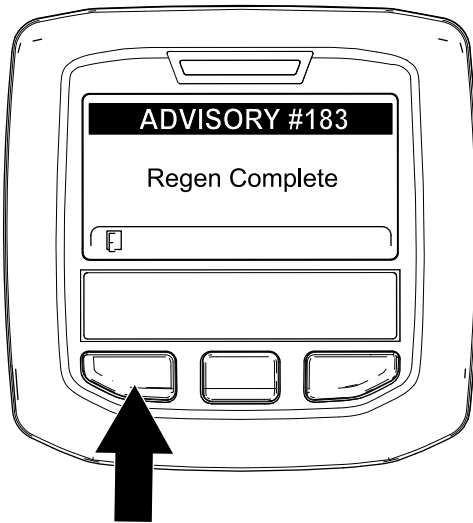

Figure 66

g224392

**Note:** If the regeneration fails to complete, the InfoCenter displays Advisory #184 (Figure 67). Press the left button to exit to the home screen.

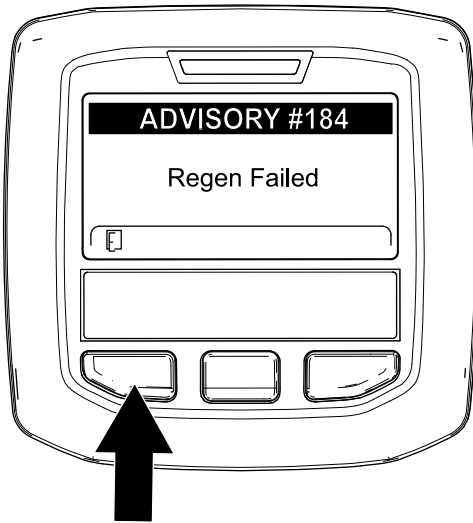

Figure 67

g224393

## Adjusting the Mowing Speed

### Supervisor (Protected Menu)

This feature allows the supervisor to set the maximum mowing speed in increments of 5% between 30 and 100%, at which the operator can mow (low range).

Refer to [Setting the Maximum Allowed Mow Speed \(page 36\)](#) for the procedure to set the mow speed.

### Operator

This feature allows the operator to adjust the maximum mowing speed (low range), within the supervisors pre-adjusted settings. When in the InfoCenter splash or main screen, press the middle button (  icon) to adjust the speed.

**Note:** When switching between low and high ranges, the settings will transfer based on the previous setting. The settings are reset when the machine is turned off.

**Note:** This feature may also be used in conjunction with cruise control.

## Using the Engine-Speed Switch

The engine speed switch has 2 modes to change the engine speed. By momentarily tapping the switch, the engine speed can be increased or decreased in 100-rpm increments. By holding the switch down, the engine automatically moves to HIGH or LOW IDLE, depending on which side of the switch you press.

# Adjusting the Transport Speed

## Supervisor (Protected Menu)

This feature allows the supervisor to set the maximum transport speed in increments of 5% between 30 and 100%, at which the operator can transport (high range).

Refer to [Setting the Maximum Allowed Transport Speed \(page 36\)](#) for the procedure to set the transport speed.

## Operator

This feature allows the operator to adjust the maximum transport speed (high range) within the supervisors pre-adjusted settings. When in the InfoCenter splash or main screen, press the middle

button ( icon) to adjust the speed.

**Note:** When switching between low and high ranges, the settings transfer based on the previous setting. The settings are reset when the machine is turned off.

**Note:** You can also use this feature in conjunction with cruise control.

# Understanding the Operating Characteristics of the Machine

Practice driving the machine, because it has a hydrostatic transmission and its characteristics are different than many turf-maintenance machines. Some points to consider when operating the traction unit, mower deck, or other implements are that the transmission, engine speed, load on the mower blades or other implement components affect machine performance.

With Toro Smart Power™, you do not need to listen to the engine speed in heavy conditions. Smart Power prevents bogging down in heavy turf by automatically controlling the machine speed and optimizing cutting performance.

You can use the brakes to assist in turning the machine. However, use them carefully, especially on soft or wet grass, because the turf may be torn accidentally. Another benefit of the brakes is to maintain traction. For example, in some slope conditions, the uphill wheel slips and loses traction. If this situation occurs, press the uphill brake pedal gradually and intermittently until the uphill wheel stops slipping, which increases traction on the downhill wheel.

Traction Assist is automatic and requires no operator input. When a wheel starts to slip, flow is automatically split between the front and rear wheels to minimize wheel slip and loss of traction.

Use extra care when operating the machine on slopes. Ensure that the ROPS is in the raised position, the seat latch is properly secured, and the seat belt is buckled. Drive slowly and avoid sharp turns on slopes to prevent rollovers. For steering control, the mower deck must be lowered when going downhill.

Before shutting off the engine, disengage all controls and change the throttle to the SLOW position. Changing the throttle to the SLOW position reduces high-engine speed, noise, and vibration. Turn the key to the OFF position to shut off the engine.

Before transporting the machine, raise the mower decks and secure the transport latches ([Figure 68](#)).

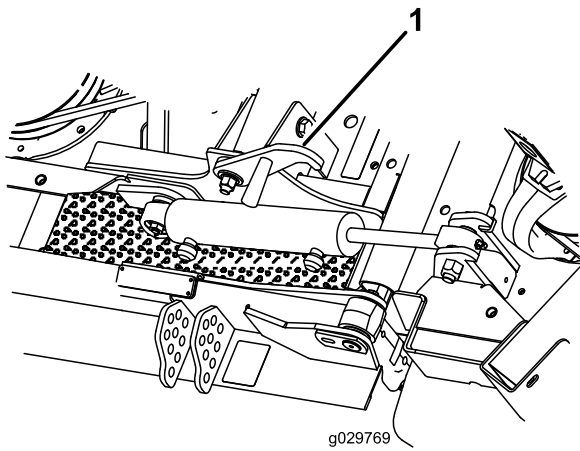

**Figure 68**

1. Transport latch (wing mower decks)

## Operating Tips

### Operating the Machine

- Start the engine and run it at the HALF IDLE position until it warms up. Move the engine-speed switch to HIGH IDLE, lift the mower decks, disengage the parking brake, press the forward traction pedal, and carefully drive to an open area.
- Practice moving forward and reverse, and starting and stopping the machine. To stop the machine, remove your foot from the traction pedal and let it return to NEUTRAL or press down on the reverse pedal.

**Note:** When going downhill in the machine, you may need to use the reverse pedal to stop.

- When possible, mow up and down hills rather than across them. Have the mower decks lowered when going down a hill to maintain steering control. Do not attempt to turn the machine on a hill.
- Practice driving around obstacles with the mower decks up and down. Be careful when driving between narrow objects so that you do not damage the machine or mower decks.
- Always drive slowly in rough areas.
- If an obstacle is in the way, lift the mower decks to mow around it.
- When transporting the machine from 1 work area to another, raise the mower decks to the fully upward position, shut off the PTO, press the mow/transport switch to the TRANSPORT position, and place the throttle in the FAST position.

## Changing Mowing Patterns

Change mowing patterns often to minimize a poor after-cut appearance from repeatedly mowing in the same direction.

## Understanding Counterbalance

The counterbalance system maintains hydraulic back pressure on the deck-lift cylinders. This pressure improves traction by transferring the mower-deck weight to the mower-drive wheels. The counterbalance pressure has been set at the factory to an optimal balance of after-cut appearance and traction capability in most turf conditions.

Decreasing the counterbalance setting can produce a more stable mower deck, but can decrease the traction capability. Increasing the counterbalance setting can increase the traction capability, but may result in a poor after-cut appearance. Refer to the machine *Service Manual* for your traction unit for instructions to adjust the counterbalance pressure.

## Resolving After-Cut Appearance

Reference the After-cut Appearance Troubleshooting Guide available at [www.Toro.com](http://www.Toro.com).

## Using Proper Mowing Techniques

- To begin cutting, engage the mower decks, then approach the mowing area slowly.
- To achieve the professional straight-line cut and striping that is desirable for some applications, find a tree or other object in the distance and drive straight toward it.
- As soon as the front mower decks reach the edge of the mowing area, perform a teardrop-shaped turn to quickly line up for your next pass.
- Bolt-in mulching baffles are available for the mower decks. The mulching baffles perform well when you maintain turf on a regular schedule to avoid removing more than 25 mm (1 inch) of growth per cutting. When you cut too much growth with the mulching baffles installed, the after-cut appearance may deteriorate and the observed power to cut the turf increases. The mulching baffles also perform well for shredding leaves in the fall.

## Selecting the Proper Height-of-Cut Setting to Suit Conditions

Remove no more than approximately 1/3 of the grass blade when cutting. In exceptionally lush and dense grass, you may need to raise your height-of-cut setting.

## Mowing with Sharp Blades

A sharp blade cuts cleanly and without tearing or shredding the grass blades like a dull blade. Tearing and shredding causes the grass to turn brown at the edges, which impairs growth and increases susceptibility to diseases. Ensure that the blade is in good condition and that there is a full sail.

- Measure the air temperature at the front center vent in the headliner.

**Note:** The air temperature typically stabilizes at less than or equal to 10°C (50°F).

- Refer to the *Service Manual* for additional information.

## After Operating

To ensure optimum performance, clean the underside of the mower housing after each use. If residue builds up in the mower housing, cutting performance decreases.

Also, remove any debris which may have collected between the deck-lift cylinders and the foam deck pads (Figure 69).

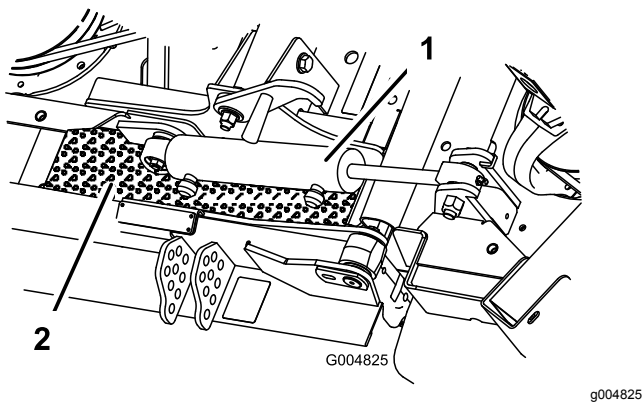

Figure 69

1. Deck-lift cylinder
2. Foam deck pad

## Mower Deck Pitch

A blade pitch of 8 to 11 mm (5/16 to 7/16 inch) is recommended. A pitch larger than 8 to 11 mm (5/16 to 7/16 inch) results in less power required, larger clippings, and a poorer quality of cut. A pitch less than 8 to 11 mm (5/16 to 7/16 inch) results in more power required, smaller clippings and a better quality of cut.

## Maximizing the Air Conditioner Performance

- To limit solar heating, park the machine in a shaded area or leave the doors open in direct sun.
- Ensure that the air-conditioning-condenser fins are clean.
- Operate the air-conditioner blower at the mid-speed setting.
- Verify that a continuous seal exists between the roof and the headliner. Correct the seal as required.

# After Operation

## After Operation Safety

- Clean grass and debris from the cutting units, mufflers, and engine compartment to help prevent fires. Clean up oil or fuel spills.
- If the cutting units are in the transport position, use the positive mechanical lock (if available) before you leave the machine unattended.
- Allow the engine to cool before storing the machine in any enclosure.
- Remove the key and shut off the fuel (if equipped) before storing or transporting the machine.
- Never store the machine or fuel container where there is an open flame, spark, or pilot light, such as on a water heater or on other appliances.
- Keep all parts of the machine in good working condition and all hardware tightened, especially blade-attachment hardware.
- Replace all worn or damaged decals.

## Pushing or Towing the Machine

In an emergency, you can move the machine forward by actuating the bypass valve in the variable-displacement hydraulic pump and pushing or towing the machine.

**Important:** Do not push or tow the machine faster than 3 to 4.8 km/h (2 to 3 mph) If you push or tow at a faster speed, internal transmission damage may occur.

The bypass valves must be open whenever you push or tow the machine.

1. Raise the seat and locate the bypass valves, which are located below the front of the fuel tank (Figure 70).

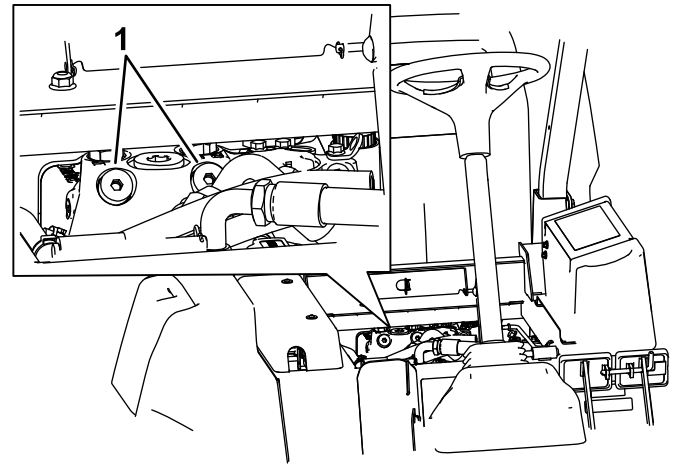

Figure 70

1. Bypass valve (2)

2. Rotate each valve 3 counter-clockwise turns to open and allow the fluid to bypass internally.

**Note:** Do not open more than 3 turns. Because the fluid is bypassed, the machine can be slowly moved without damaging the transmission.

3. Push or tow the machine.
4. Finish pushing or towing the machine and close the bypass valves. Torque the valve to 70 N·m (52 ft-lb).

**Important:** Ensure that the bypass valve is closed before you start the engine. Running the engine with an open bypass valve causes the transmission to overheat.

**Important:** If you must push or tow the machine in reverse, bypass the check valve in the 4-wheel drive manifold.

To bypass the check valve, connect a hose assembly to the reverse traction pressure test port (located on the hydrostat) and on the port located between ports M8 and P2 on the rear traction manifold (located behind the front tire). The hose assembly includes 1 hose (Part No. 95-8843), 2 coupler fittings (Part No. 95-0985), and 2 hydraulic fittings (Part No. 340-77).

## Locating the Jacking Points

### **⚠ DANGER**

Mechanical or hydraulic jacks may fail to support machine and cause a serious injury.

- Use jack stands when supporting the machine.
- Do not use hydraulic jacks.

There are jacking points located at the front and rear of the machine.

- On the frame at the inside of each front drive tire
- At the center of the rear axle

## Hauling the Machine

- Remove the key and shut off the fuel (if equipped) before storing or transporting the machine.
- Use care when loading or unloading the machine into a trailer or a truck.
- Use full-width ramps for loading the machine into a trailer or a truck.
- Tie the machine down securely.

## Locating the Tie-Down Points

There are tie downs located at the front and rear sides of the machine ([Figure 71](#)).

**Note:** Use properly-rated DOT-approved straps in 4 corners to tie down the machine.

- 2 on the front of the operator's platform
- Rear bumper

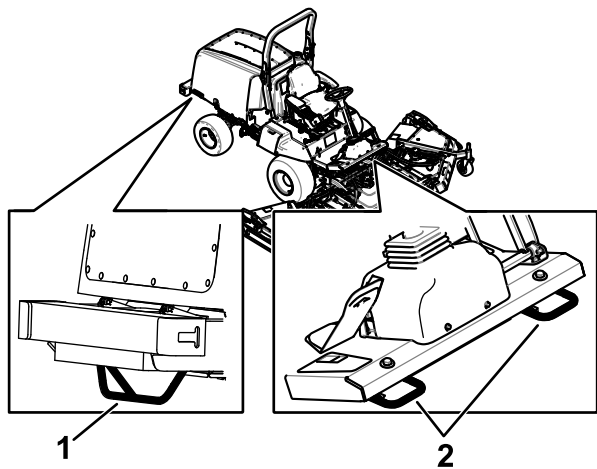

g203193

**Figure 71**

1. Rear tie-down point      2. Front tie-down points
-

# Maintenance

**Note:** Determine the left and right sides of the machine from the normal operating position.

**Important:** Refer to your engine owner's manual for additional maintenance procedures.

**Note:** Download a free copy of the electrical or hydraulic schematic by visiting [www.Toro.com](http://www.Toro.com) and searching for your machine from the Manuals link on the home page.

## Recommended Maintenance Schedule(s)

Maintenance Service Interval	Maintenance Procedure
After the first hour	<ul style="list-style-type: none"> <li>• Torque the wheel lug nuts.</li> </ul>
After the first 10 hours	<ul style="list-style-type: none"> <li>• Torque the wheel lug nuts.</li> <li>• Check the alternator-belt tension.</li> <li>• Check the compressor belt tension.</li> <li>• Check the blade-drive-belt tension.</li> </ul>
After the first 50 hours	<ul style="list-style-type: none"> <li>• Change the engine oil and filter.</li> </ul>
After the first 200 hours	<ul style="list-style-type: none"> <li>• Change the front planetary-gear oil.</li> <li>• Change the rear-axle lubricant.</li> <li>• Change the hydraulic filters.</li> </ul>
Before each use or daily	<ul style="list-style-type: none"> <li>• Check the tire pressure.</li> <li>• Check the safety-interlock switches.</li> <li>• Check the engine-oil level.</li> <li>• Check the air-cleaner indicator</li> <li>• Drain water or other contaminants from the water separator.</li> <li>• Check the coolant level.</li> <li>• Check the hydraulic-fluid level.</li> </ul>
Every 25 hours	<ul style="list-style-type: none"> <li>• Check the electrolyte level (or every 30 days if the machine is in storage).</li> </ul>
Every 50 hours	<ul style="list-style-type: none"> <li>• Lubricate all bearings and bushings.</li> <li>• Inspect the air cleaner.</li> <li>• Check the condition of the battery.</li> <li>• Check the blade-drive-belt tension.</li> </ul>
Every 100 hours	<ul style="list-style-type: none"> <li>• Inspect the cooling-system hoses and clamps.</li> <li>• Check the alternator-belt tension.</li> <li>• Check the compressor belt tension.</li> </ul>
Every 200 hours	<ul style="list-style-type: none"> <li>• Torque the wheel lug nuts.</li> </ul>
Every 250 hours	<ul style="list-style-type: none"> <li>• Change the engine oil and filter.</li> <li>• Clean the cab air filters; replace them if they are torn or excessively dirty.</li> <li>• Clean the air-conditioning coil. (Clean more frequently in extremely dusty or dirty conditions)</li> </ul>
Every 400 hours	<ul style="list-style-type: none"> <li>• Service the air cleaner (earlier if the air cleaner indicator shows red, and more frequently in extremely dirty or dusty conditions).</li> <li>• Inspect the fuel lines and connections.</li> <li>• Replace the filter canister.</li> <li>• Check the planetary-gear-drive oil (check if you notice external leakage).</li> <li>• Check for end-play in the planetary drives.</li> <li>• Check the rear-axle lubricant.</li> <li>• Check the rear-axle-gearbox lubricant.</li> </ul>

Maintenance Service Interval	Maintenance Procedure
Every 800 hours	<ul style="list-style-type: none"> <li>• Drain and clean the fuel tank (also if the fuel system is contaminated).</li> <li>• Change the front planetary-gear oil.</li> <li>• Change the rear-axle lubricant.</li> <li>• Check the rear wheel toe-in.</li> <li>• Inspect the blade-drive belt.</li> <li>• Change the hydraulic fluid.</li> <li>• Change the hydraulic filters.</li> <li>• Inspect the mower deck caster-wheel assemblies.</li> </ul>
Every 6,000 hours	<ul style="list-style-type: none"> <li>• Disassemble, clean, and assemble the soot filter of the DPF. or clean the soot filter if active faults SPN 3251 HIGH, SPN 3720 TOO HIGH SEVERE, or SPN 3720 HIGH display in the InfoCenter.</li> </ul>
Every 2 years	<ul style="list-style-type: none"> <li>• Flush the cooling system and replace the fluid.</li> <li>• Replace moving hoses.</li> </ul>

**⚠ CAUTION**

If you leave the key in the ignition switch, someone could accidentally start the engine and seriously injure you or other bystanders.

Remove the key from the ignition before you do any maintenance.

## Daily Maintenance Checklist

Duplicate this page for routine use.

Maintenance Check Item	For the week of:						
	Monday	Tuesday	Wednesday	Thursday	Friday	Saturday	Sunday
Check the safety-interlock operation.							
Check the brake operation.							
Check the engine-oil level.							
Check the cooling-system-fluid level.							
Drain the water/fuel separator.							
Check the air filter, dust cup, and burp valve.							
Check for unusual engine noises. <sup>1</sup>							
Check the radiator and screen for debris							
Check for unusual operating noises.							
Check the hydraulic-fluid level.							
Check the hydraulic hoses for damage.							
Check for fluid leaks.							
Check the fuel level.							
Check the tire pressure.							
Check the instrument operation.							



Maintenance Check Item	For the week of:						
	Monday	Tuesday	Wednesday	Thursday	Friday	Saturday	Sunday
Check the height-of-cut adjustment.							
Lubricate all the grease fittings. <sup>2</sup>							
Touch up any damaged paint.							
<sup>1</sup> Check the glow plug and injector nozzles if starting is hard, there is excess smoke, or rough running is noted. <sup>2</sup> Immediately <b>after every</b> washing, regardless of the interval listed.							

**Important:** Refer to your engine operator’s manual for additional maintenance procedures.

**Notation for Areas of Concern**

Inspection performed by:		
Item	Date	Information

# Pre-Maintenance Procedures

## Maintenance Safety

- Before adjusting, cleaning, repairing, or leaving the machine, do the following:
  - Park the machine on a level surface.
  - Move the throttle switch to the low-idle position.
  - Disengage the cutting units.
  - Lower the cutting units.
  - Ensure that the traction is in neutral.
  - Engage the parking brake.
  - Shut off the engine and remove the key.
  - Wait for all moving parts to stop.
  - Allow machine components to cool before performing maintenance.
- If the cutting units are in the transport position, use the positive mechanical lock (if available) before you leave the machine unattended.
- If possible, do not perform maintenance while the engine is running. Keep away from moving parts.
- Use jack stands to support the machine or components when required.
- Carefully release pressure from components with stored energy.

## Opening the Hood

1. Close the rear window of the cab (Figure 72).

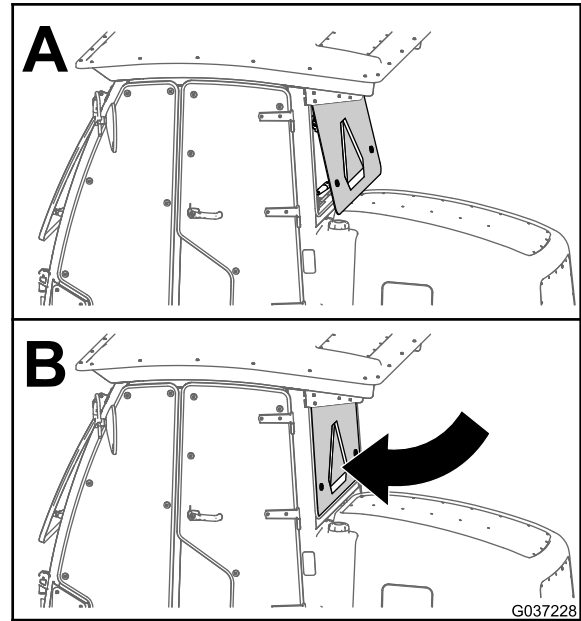
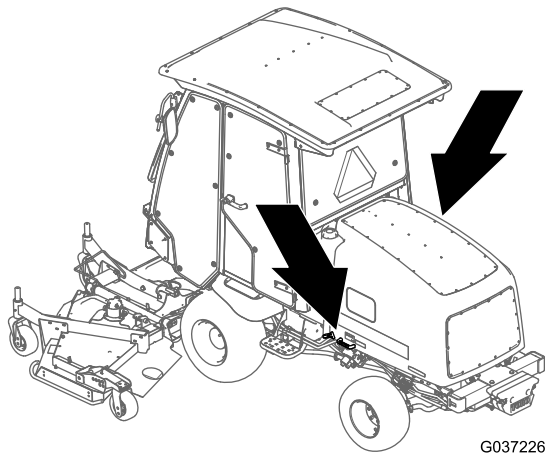

Figure 72

g037228

2. Release the 2 latches at the forward lower corners of the hood (Figure 73).



G037226

g037226

## Removing the Hood

1. Unlatch and raise the hood.
2. Remove the hairpin cotter securing the hood pivot to the mounting brackets (Figure 74).

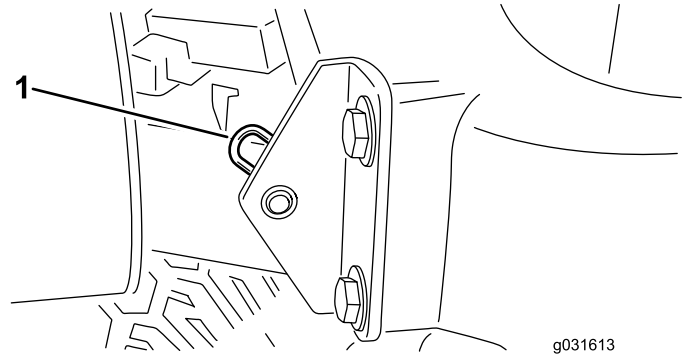

g031613

g031613

Figure 74

1. Hairpin cotter

3. Slide the hood to the right side, lift the other side, and pull it out of the brackets.

**Note:** Reverse this procedure to install the hood.

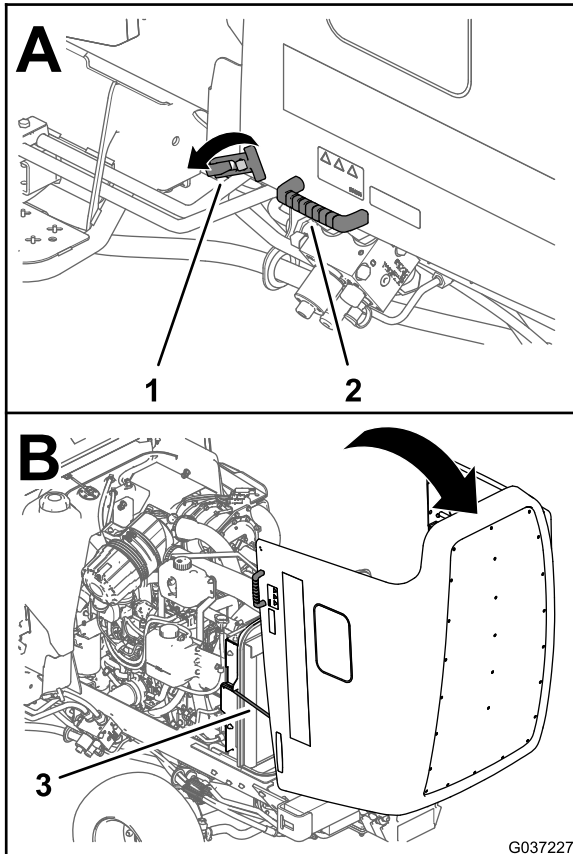

G037227

g037227

Figure 73

1. Hood latch
2. Handle
3. Prop rod

3. Using the handles that are adjacent to the latches, lift up and back the hood until the 2 prop rods are seated in the 2 rod brackets (Figure 73).

# Lubrication

## Greasing the Bearings and Bushings

**Service Interval:** Every 50 hours

The machine has grease fittings that you must lubricate regularly with No. 2 lithium grease. Also, lubricate the machine immediately after every washing.

The grease-fitting locations and quantities are:

### Traction Unit

- 2 brake pedal pivot-shaft bearings (Figure 75)
- 2 front and rear-axle-pivot bushings (Figure 76)
- 2 steering-cylinder-ball joints (Figure 77)
- 2 tie-rod-ball joints (Figure 77)
- 2 king-pin bushings (Figure 77).

**Note:** Lubricate only the top fitting on the king pin annually (2 pumps).

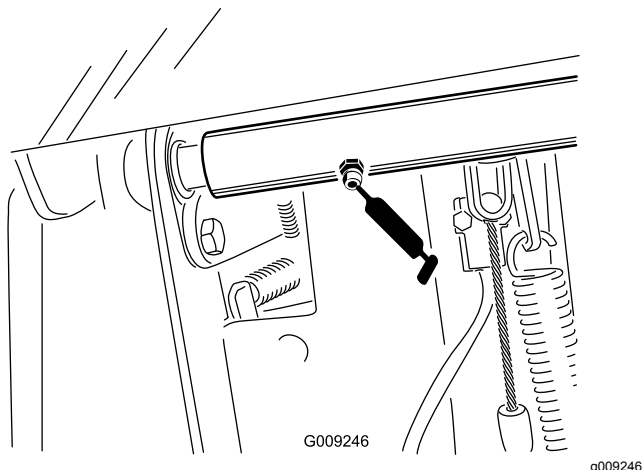

Figure 75

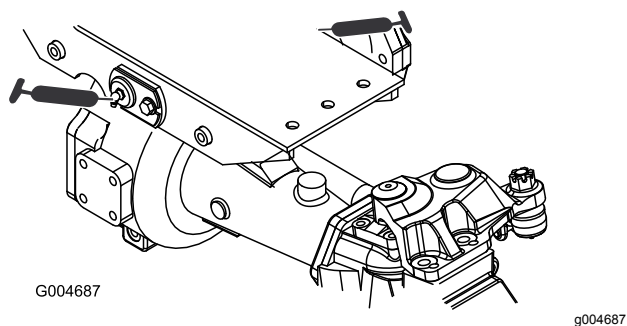

Figure 76

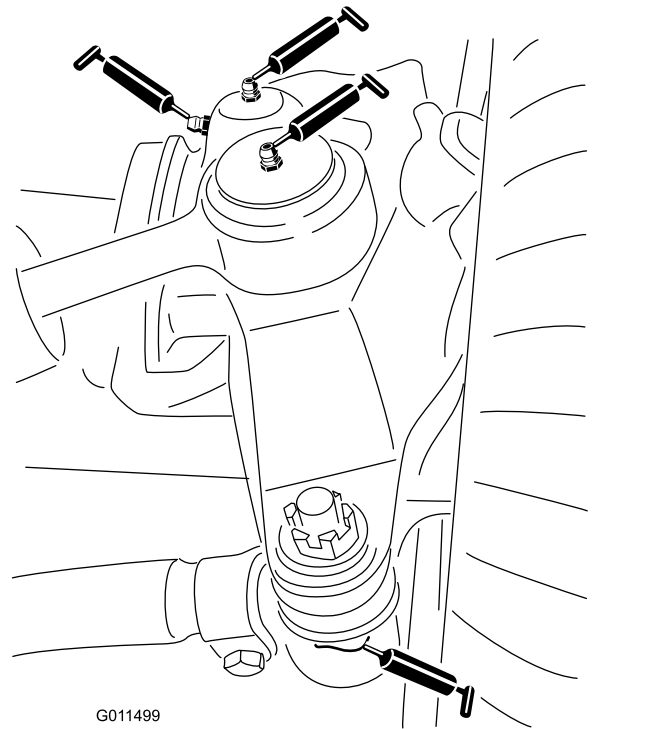

Figure 77

### Center Mower Deck

**Note:** You may need to raise the deck to expose the grease fittings for the latch pivot and the lower link.

- 2 latch pivots (Figure 79)

**Note:** You may need to manually trip the latches to gain access to the grease fittings (Figure 78). Use a pry bar to close and open the latch.

- 2 caster-fork-shaft bushings (Figure 80)
- 3 spindle-shaft bearings—located under the pulley (Figure 81)
- 2 idler-arm-pivot bushings (Figure 81)

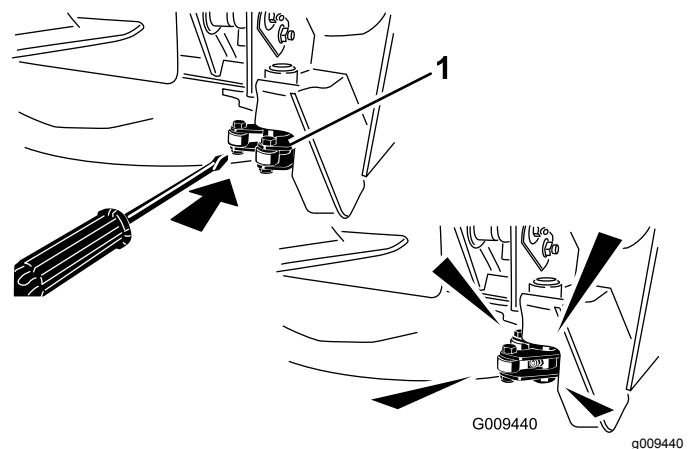
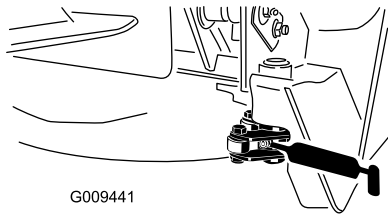

Figure 78

1. Latch



G009441

**Figure 79**

g009441

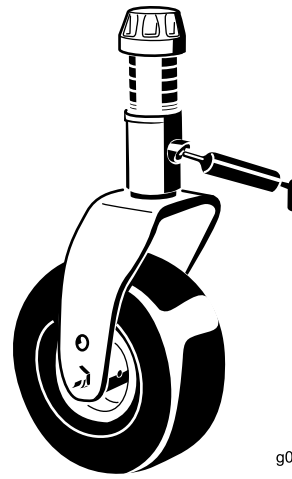

g011557

**Figure 80**

g011557

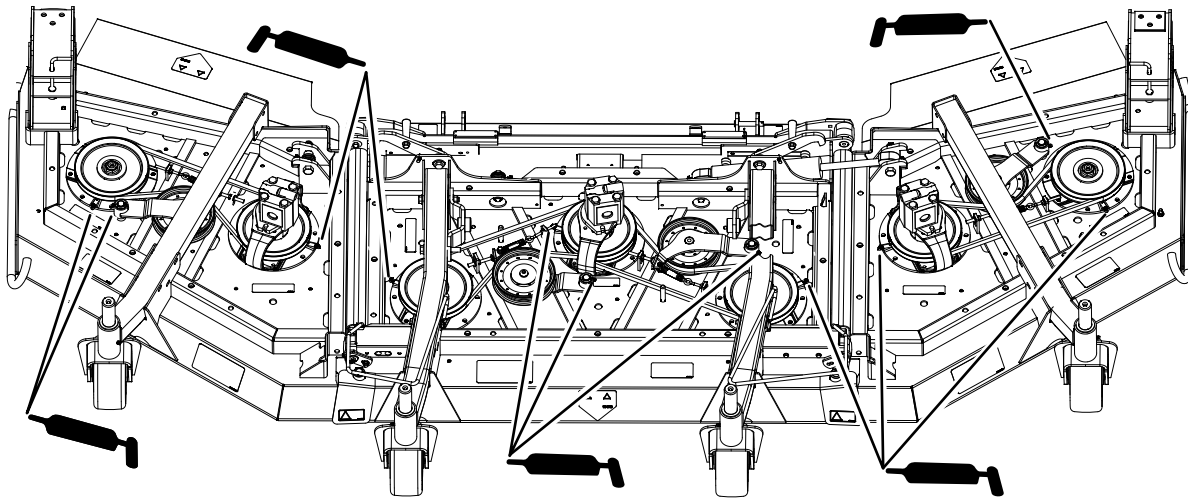
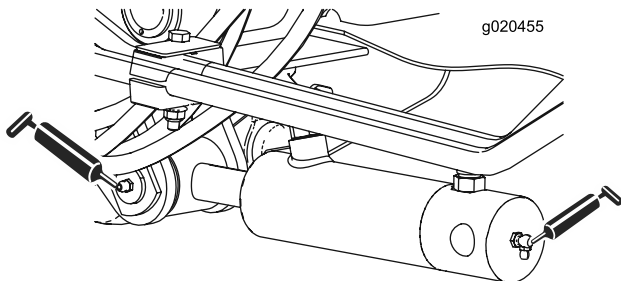

**Figure 81**

g244640

## Center-Deck-Lift Assemblies

- 2 (each side) lift-arm-cylinder bushings (Figure 82)
- 2 lift-arm ball joints (Figure 83)



g020455

**Figure 82**

g020455

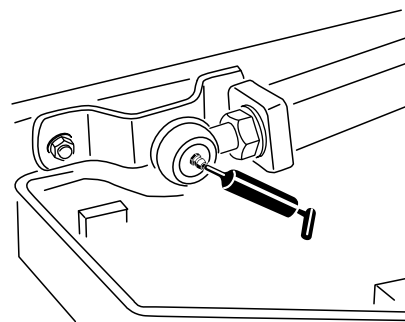

g011551

**Figure 83**

g011551

## Wing-Deck-Lift Assemblies

The 4 wing deck-lift cylinder (Figure 84)

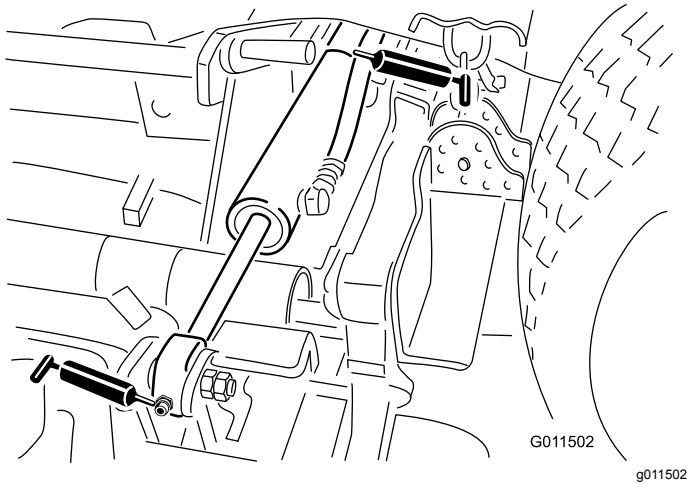

Figure 84

## Wing Mower Decks

- 1 caster-fork-shaft bushing (Figure 85)
- 2 (each side) spindle-shaft bearings—located under the pulley
- 1 idler-arm-pivot bushings—located on the idler arm

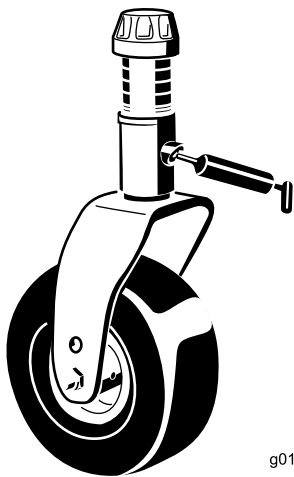

Figure 85

## Engine Maintenance

### Engine Safety

- Shut off the engine and remove the key before checking the oil or adding oil to the crankcase.
- Do not change the governor speed or overspeed the engine.

### Servicing the Engine Oil

#### Oil Specification

Use high-quality, low-ash engine oil that meets or exceeds the following specifications:

- API service category CJ-4 or higher
- ACEA service category E6
- JASO service category DH-2

**Important:** Using engine oil other than API CJ-4 or higher, ACEA E6, or JASO DH-2 may cause the diesel particulate filter to plug or cause engine damage.

Use the following engine oil viscosity grade:

- Preferred oil: SAE 15W-40 (above 0°F)
- Alternate oil: SAE 10W-30 or 5W-30 (all temperatures)

Toro Premium Engine Oil is available from your authorized Toro distributor in either 15W-40 or 10W-30 viscosity grades. See the *Parts Catalog* for part numbers.

### Checking the Engine-Oil Level

**Service Interval:** Before each use or daily

The engine is shipped with oil in the crankcase; however, the oil level must be checked before and after the engine is first started.

**Important:** Check the engine oil daily. If the engine-oil level is above the Full mark on the dipstick, the engine oil may be diluted with fuel; If the engine oil level is above the Full mark, change the engine oil.

The best time to check the engine oil is when the engine is cool before it has been started for the day. If it has already been run, allow the oil to drain back down to the sump for at least 10 minutes before checking. If the oil level is at or below the Add mark on the dipstick, add oil to bring the oil level to the Full mark. **Do not overfill the engine with oil.**

**Important:** Keep the engine-oil level between the upper and lower limits on the dipstick; the engine may fail if you run it with too much or too little oil.

Check the engine-oil level; refer to [Figure 86](#).

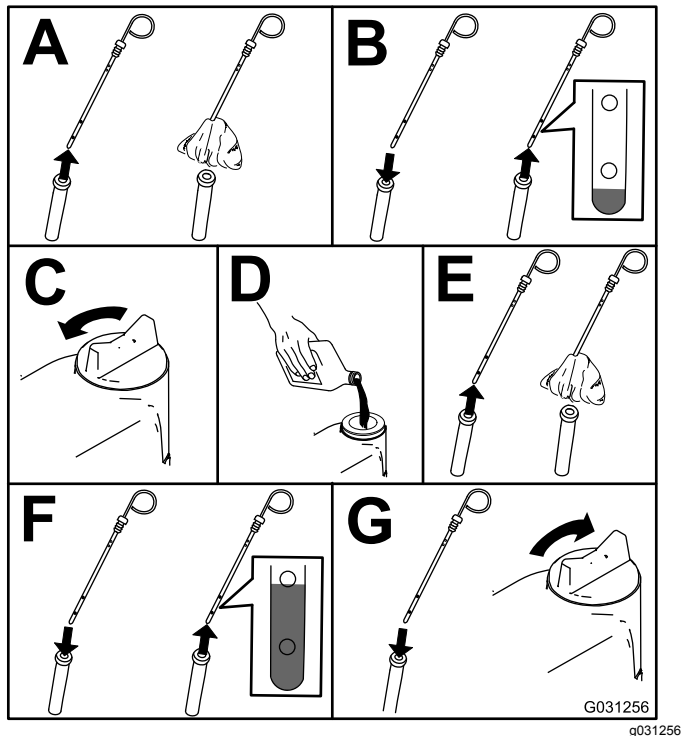

Figure 86

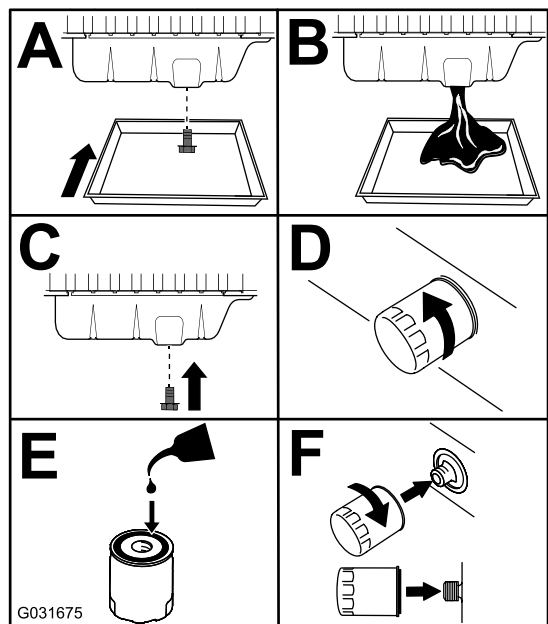

Figure 87

4. Add oil to the crankcase.

**Note:** When using different oil, drain all old oil from the crankcase before adding new oil.

## Crankcase Oil Capacity

Approximately 5.7 L (6 US qt) with the filter.

## Changing the Engine Oil and Filter

**Service Interval:** After the first 50 hours

Every 250 hours

1. Start the engine and let it run 5 minutes to allow the oil to warm up.
2. With the machine parked on a level surface, shut off the engine, remove the key, and wait for all moving parts to stop before leaving the operating position.
3. Replace the engine oil and filter ([Figure 87](#)).

## Servicing the Air Cleaner

**Service Interval:** Before each use or daily—Check the air-cleaner indicator

Every 50 hours—Inspect the air cleaner.

Every 400 hours—Service the air cleaner (earlier if the air cleaner indicator shows red, and more frequently in extremely dirty or dusty conditions).

Check the air-cleaner body for damage, which could cause an air leak. Replace it if it is damaged. Check the whole intake system for leaks, damage, or loose hose clamps.

Service the air-cleaner filter only when the service indicator requires it ([Figure 88](#)). Changing the air filter before it is necessary only increases the chance of dirt entering the engine when you remove the filter.

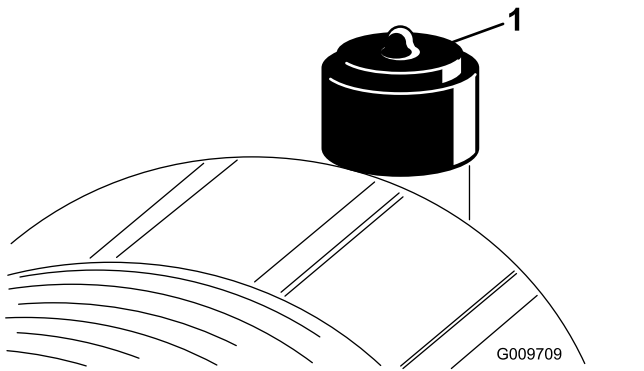
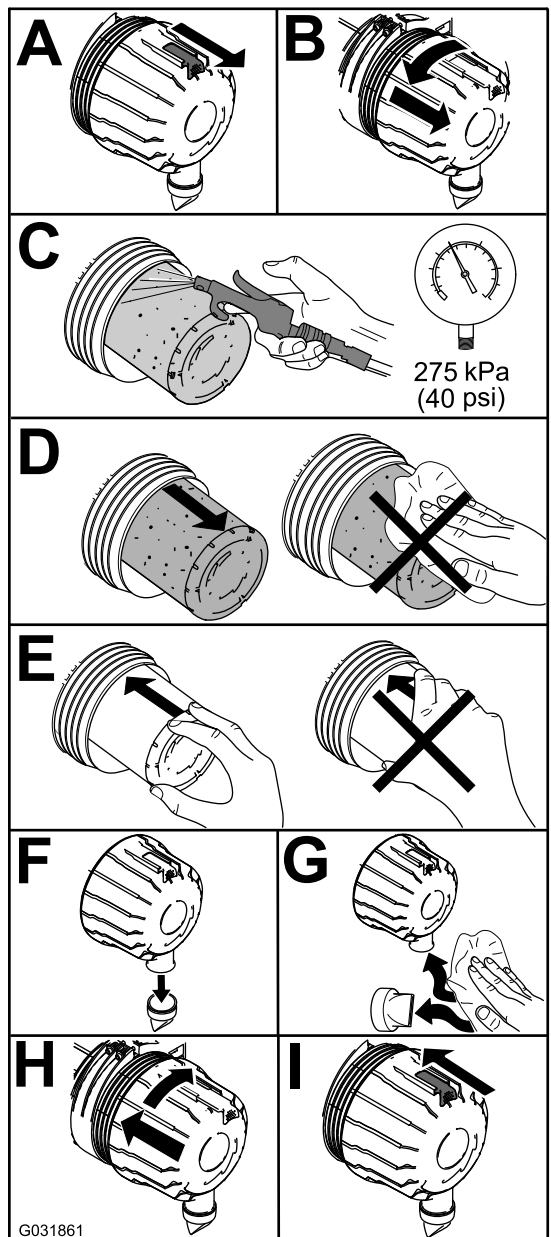

**Figure 88**

1. Air-cleaner indicator

**Important:** Be sure that the cover is seated correctly and seals with the air-cleaner body.

1. Replace the air cleaner (Figure 89).

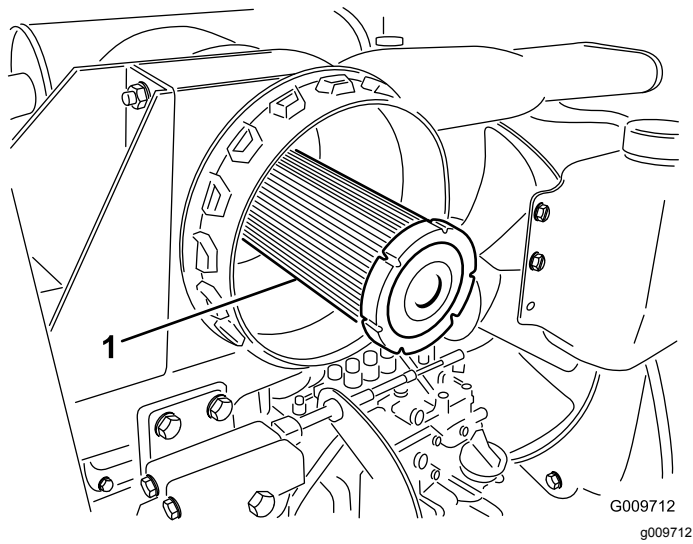

**Figure 89**

**Note:** Do not clean the used element due to the possibility of damage to the filter media.

**Important:** Never attempt to clean the safety filter (Figure 90). Replace the safety filter after every 3 primary filter services.





**Figure 90**

1. Air-cleaner safety filter

2. Reset the indicator ([Figure 88](#)) if it shows red.

## Servicing the Diesel-Oxidation Catalyst (DOC) and the Soot Filter

**Service Interval:** Every 6,000 hours or clean the soot filter if active faults SPN 3251 HIGH, SPN 3720 TOO HIGH SEVERE, or SPN 3720 HIGH display in the InfoCenter.

If engine faults ACTIVE FAULT SPN 3251 HIGH, ACTIVE FAULT SPN 3720 TOO HIGH SEVERE, or ACTIVE FAULT SPN 3720 HIGH in the InfoCenter ([Figure 91](#)) display in the InfoCenter, clean the soot filter using the steps that follow:

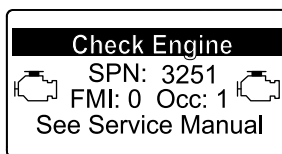

**Figure 91**

g214715

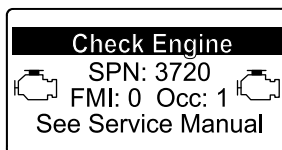

**Figure 92**

g213864

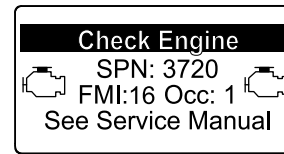

**Figure 93**

g213863

1. Refer to the Engine section in the *Service Manual* for information on disassembling and assembling the diesel-oxidation catalyst and the soot filter of the DPF.
2. Refer to your authorized Toro distributor for diesel-oxidation catalyst and the soot filter replacement parts or service.
3. Contact your authorized Toro distributor to have them reset the engine ECU after you install a clean DPF.

# Fuel System Maintenance

## Servicing the Fuel System

### Draining the Fuel Tank

**Service Interval:** Every 800 hours (also if the fuel system is contaminated).

Use clean fuel to flush out the tank.

### Inspecting the Fuel Lines and Connections

**Service Interval:** Every 400 hours

Inspect the fuel lines and connections for deterioration, damage, or loose connections.

### Servicing the Water Separator

**Service Interval:** Before each use or daily—Drain water or other contaminants from the water separator.

Every 400 hours—Replace the filter canister.

Service the water separator as shown in [Figure 94](#).

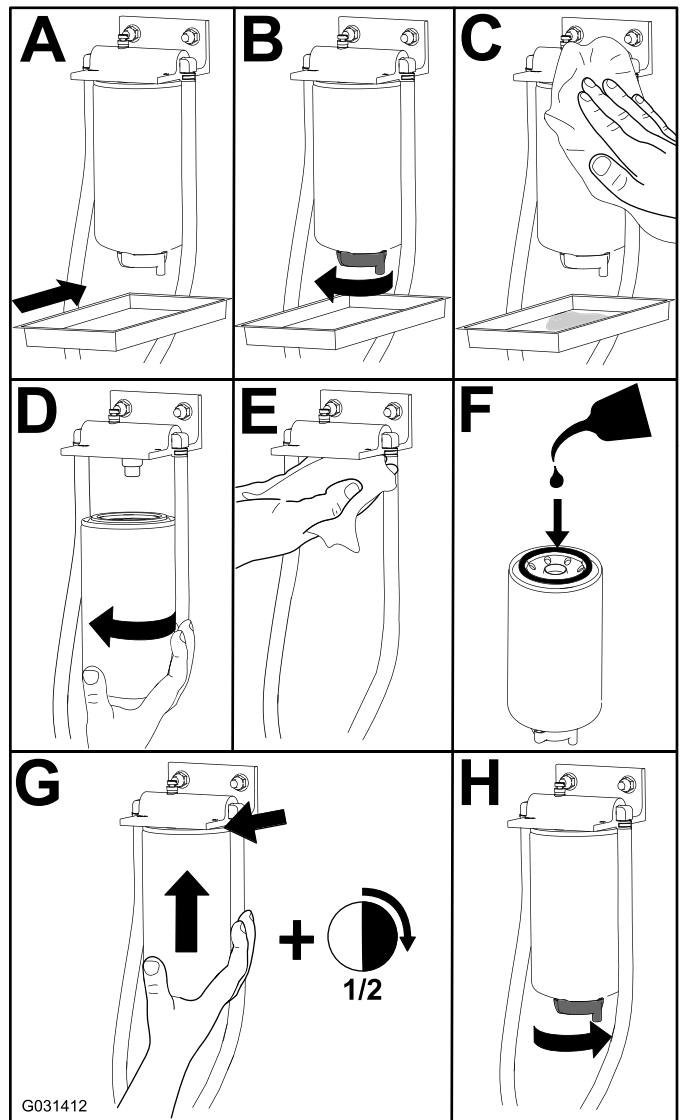

Figure 94

# Electrical System Maintenance

## Electrical System Safety

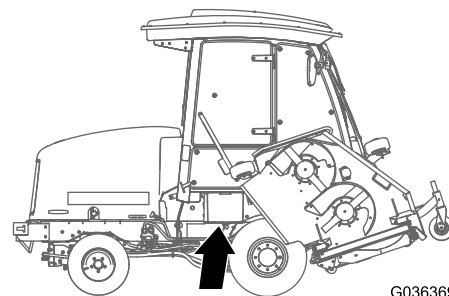

Figure 95

### WARNING

#### CALIFORNIA Proposition 65 Warning

Battery posts, terminals, and related accessories contain lead and lead compounds, chemicals known to the State of California to cause cancer and reproductive harm. Wash hands after handling.

- Disconnect the battery before repairing the machine. Disconnect the negative terminal first and the positive last. Connect the positive terminal first and the negative last.
- Charge the battery in an open, well-ventilated area, away from sparks and flames. Unplug the charger before connecting or disconnecting the battery. Wear protective clothing and use insulated tools.

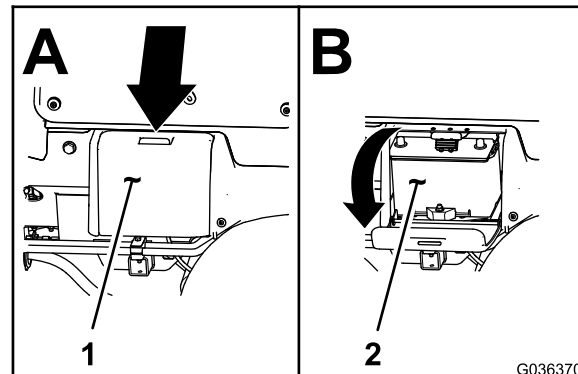

Figure 96

1. Battery cover
2. Battery

## Servicing the Battery

**Service Interval:** Every 25 hours—Check the electrolyte level (or every 30 days if the machine is in storage).

Every 50 hours—Check the condition of the battery.

**Important:** Before welding on the machine, disconnect the negative cable from the battery to prevent damage to the electrical system.

**Note:** Keep the terminals and the entire battery case clean because a dirty battery discharges slowly. To clean the battery, wash the entire case with a solution of baking soda and water. Rinse with clear water. Coat the battery posts and cable connectors with Grafo 112X (skin-over) grease (Toro Part No. 505-47) or petroleum jelly to prevent corrosion.

1. Open the battery cover on the side of the shroud (Figure 95).

**Note:** Press down on the flat surface above the battery cover to ease the removal of the cover (Figure 95).

### ⚠ WARNING

Battery terminals or metal tools could short against metal components causing sparks. Sparks can cause the battery gasses to explode, resulting in personal injury.

- When removing or installing the battery, do not allow the battery terminals to touch any metal parts of the machine.
- Do not allow metal tools to short between the battery terminals and metal parts of the machine.

## ⚠ WARNING

Incorrect battery cable routing could damage the machine and cables causing sparks. Sparks can cause the battery gasses to explode, resulting in personal injury.

- Always *disconnect* the negative (black) battery cable before disconnecting the positive (red) cable.
  - Always *connect* the positive (red) battery cable before connecting the negative (black) cable.
3. Coat both battery connections with Grafo 112X (skin-over) grease (Toro Part No. 505-47), petroleum jelly, or light grease to prevent corrosion.
  4. Slide the rubber boot over the positive terminal.
  5. Close the battery cover.

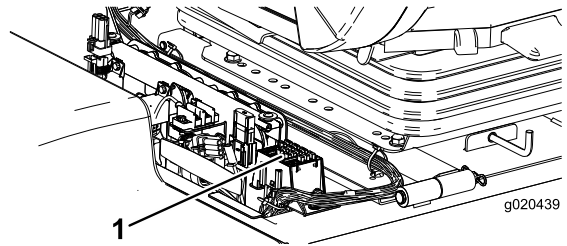

Figure 98

1. Fuses

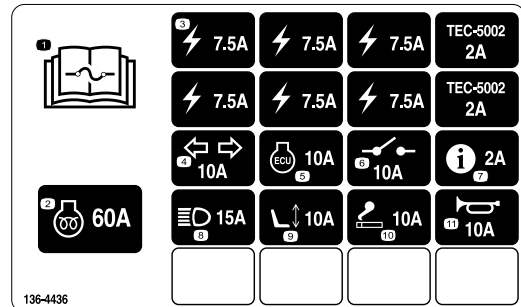

Figure 99

## Servicing the Fuses

The traction unit fuses (Figure 97 thru Figure 99) are located under the power-center cover.

Remove the 2 Allen-head screws securing the power-center cover to the frame and remove the cover (Figure 97).

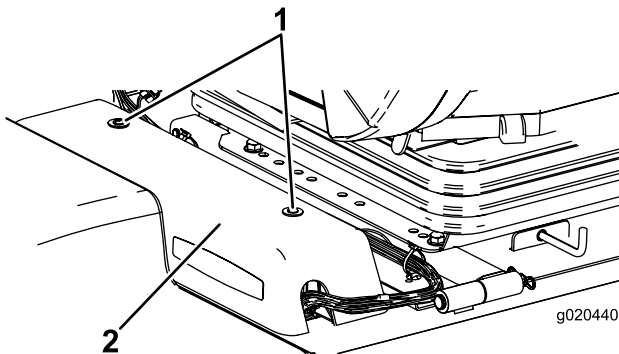

Figure 97

1. Power-center cover
2. Allen-head screws (2)

The cab fuses (Figure 100 and Figure 101) are located in the fuse box in the cab headliner (Cab model only).

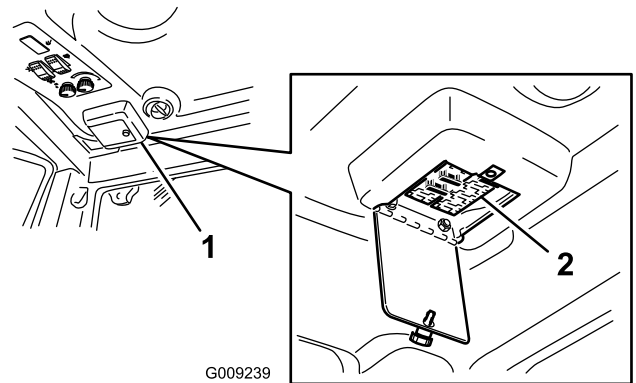

Figure 100

1. Cab fuse box
2. Fuses

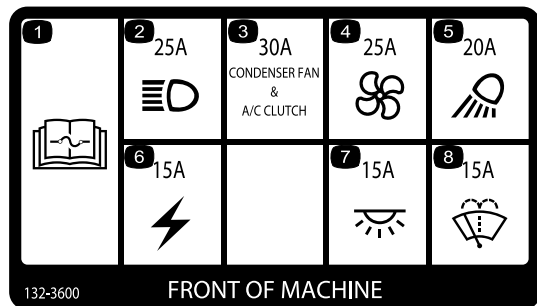
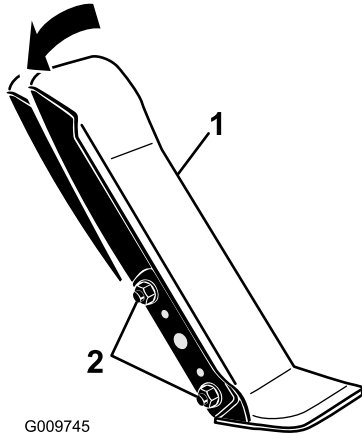

Figure 101

# Drive System Maintenance

## Adjusting the Traction-Pedal Angle

1. Loosen the 2 nuts and bolts securing the left side of the traction pedal to the bracket (Figure 102).



G009745

g009745

Figure 102

1. Traction pedal
2. Mounting nuts and bolts

2. Pivot the pedal to the desired operating angle and tighten the nuts (Figure 102).

## Checking the Planetary-Gear-Drive Oil

**Service Interval:** Every 400 hours—Check the planetary-gear-drive oil (check if you notice external leakage).

Every 400 hours—Check for end-play in the planetary drives.

Use high quality SAE 85W-140 gear lube as a replacement.

1. With machine on level surface, position the wheel so 1 check plug is at the 12 o'clock position and the other is at 3 o'clock position (Figure 103).

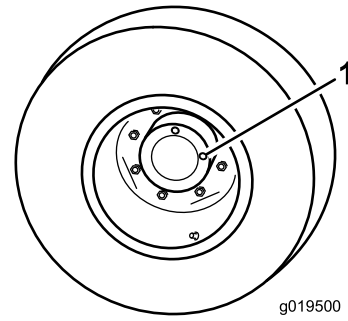

g019500

g019500

Figure 103

1. Check/drain plug (2)
2. Remove the plug at the 3 o'clock position (Figure 103).  
**Note:** The oil level should be at the bottom of the check-plug hole.
3. If the oil level is low, remove the plug at the 12 o'clock position and add oil until it begins to flow out of the hole at the 3 o'clock position.
4. Install both plugs.

## Changing the Planetary-Gear-Drive Oil

**Service Interval:** After the first 200 hours

Every 800 hours/Yearly (whichever comes first)

1. With the machine on a level surface, position a wheel so a check plug is at the lowest (6 o'clock) position (Figure 104).

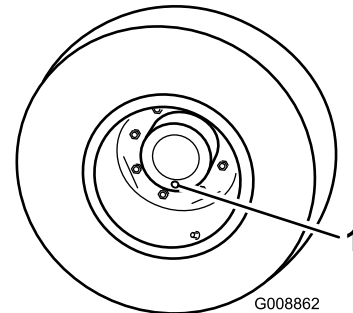

G008862

g008862

Figure 104

1. Check/drain plug
2. Place a drain pan under the planetary hub, remove the plug, and allow the oil to drain.
3. Place a drain pan under the brake housing, remove the drain plug, and allow the oil to drain (Figure 105).

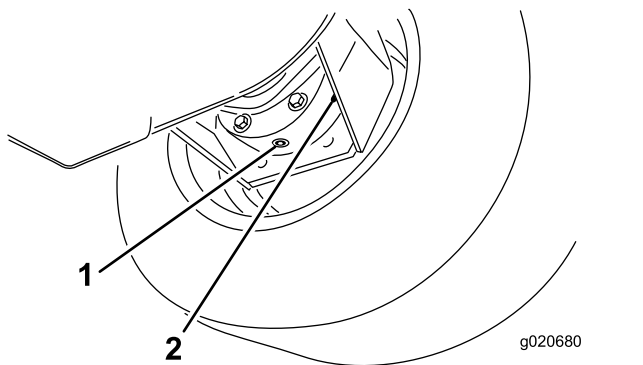

Figure 105

1. Drain plug
2. Brake housing

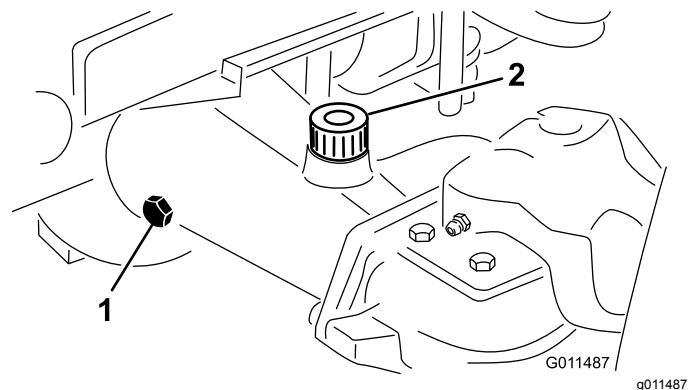

Figure 106

1. Check plug
2. Fill plug

4. When all of the oil has drained from both locations, install the plug in the brake housing.
5. Rotate the wheel until the open plug hole in the planetary is at the 12 o'clock position.
6. Through the open hole, slowly fill the planetary with 0.65 L (22 fl oz) of high quality SAE 85W-140 wt gear lube.

**Important:** If the planetary fills before the 0.65 L (22 fl oz) of oil is added, wait 1 hour or install the plug and move the machine approximately 3 m (10 ft) to distribute the oil through the brake system. Then, remove the plug and add the remaining oil.

7. Install the plug.
8. Repeat the procedure on the opposite planetary/brake assembly.

## Checking the Rear-Axle Lubricant

**Service Interval:** Every 400 hours

The rear axle is filled with SAE 85W-140 gear lube. Check the lubricant level before you first start the engine and as recommended. The capacity is 2.4 L (80 fl oz). Visually inspect for leaks daily.

1. Position the machine on a level surface.
2. Remove a check plug from the end of the axle and ensure that the lubricant is up to the bottom of the hole (Figure 106).

**Note:** If the level is low, remove the fill plug and add enough lubricant to bring the level up to the bottom of the check-plug holes.

## Checking the Rear-Axle-Gearbox Lubricant

**Service Interval:** Every 400 hours

The gearbox is filled with SAE 85W-140 gear lube. The capacity is 0.5 L (16 fl oz). Visually inspect for leaks daily.

1. Position the machine on a level surface.
2. Remove the check/fill plug from the left side of the gearbox and ensure that lubricant is up to the bottom of the hole (Figure 107).

**Note:** If the level is low, add enough lubricant to bring the level up to the bottom of the hole.

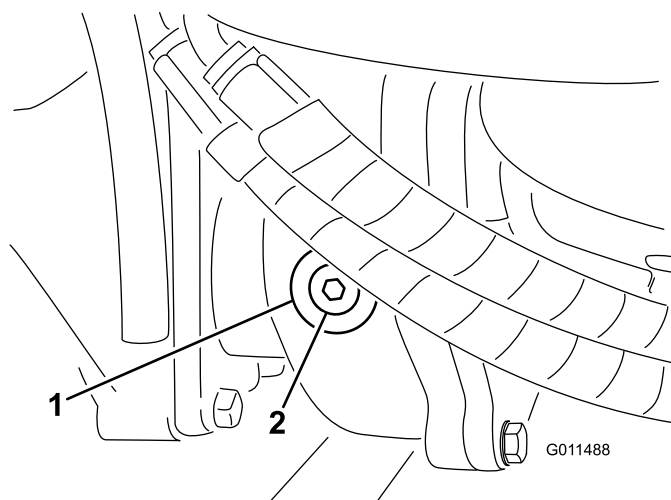

Figure 107

1. Gearbox
2. Check/fill plug

# Changing the Rear-Axle Lubricant

**Service Interval:** After the first 200 hours

Every 800 hours

1. Position the machine on a level surface.
2. Clean the area around the 3 drain plugs; 1 on each end and 1 in the center ([Figure 108](#)).
3. Remove the check plugs to ease in the draining of the oil.
4. Remove the drain plugs and allow the oil to drain into the pans.

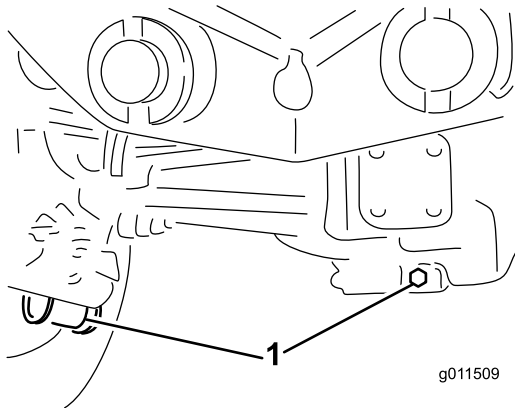
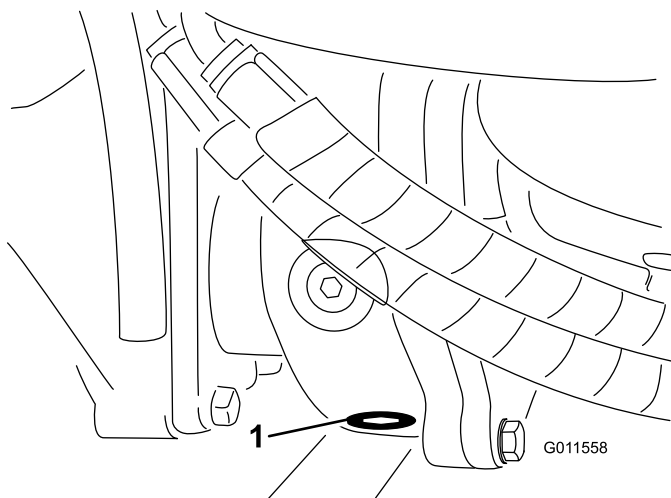

**Figure 108**

1. Drain-plug location

- 
5. Clean the area around the drain plug at the bottom of the gearbox ([Figure 109](#)).
  6. Remove the drain plug from the gearbox and allow the oil to drain into a pan.

**Note:** Remove the fill plug to ease in the draining of the oil.



**Figure 109**

1. Drain plug

7. Add enough oil to bring the level up to the bottom of the check plug holes; refer to [Changing the Rear-Axle Lubricant \(page 72\)](#), and [Checking the Rear-Axle-Gearbox Lubricant \(page 71\)](#).
8. Install the plugs.

# Checking the Rear Wheel Toe-In

**Service Interval:** Every 800 hours

1. Measure the center-to-center distance (at axle height) at the front and rear of the steering tires.

**Note:** The front measurement must be 6 mm (1/4 inch) less than the rear measurement.

2. To adjust, loosen the clamps at both ends of the tie rods.
3. Rotate the tie-rod end to move the front of the tire inward or outward.
4. Tighten the tie-rod clamps when the adjustment is correct.

# Changing the Front Tires

1. Lower the wing mower decks to the ground.
2. Raise the front of the machine several inches off the ground and support it with jackstands.
3. Refer to [Pivoting \(Tilting\) the Center Mower Deck to the Upright Position \(page 80\)](#).
4. Pivot the mower deck forward so you can remove the tire.



# Cooling System Maintenance

## Cooling System Safety

- Swallowing engine coolant can cause poisoning; keep out of reach from children and pets.
- Discharge of hot, pressurized coolant or touching a hot radiator and surrounding parts can cause severe burns.
  - Always allow the engine to cool at least 15 minutes before removing the radiator cap.
  - Use a rag when opening the radiator cap, and open the cap slowly to allow steam to escape.
- Do not operate the machine without the covers in place.
- Keep your fingers, hands and clothing clear of rotating fan and drive belt.
- Shut off the engine and remove the key before performing maintenance.

## Checking the Cooling System

**Service Interval:** Before each use or daily

Check the coolant level at the beginning of each day. The capacity of the system is 8.5 L (9 US qt).

1. Carefully remove the radiator cap and expansion-tank cap (Figure 110).
2. Check the coolant level in the radiator.

**Note:** The radiator should be filled to the top of the filler neck and the expansion tank filled to the Full mark.

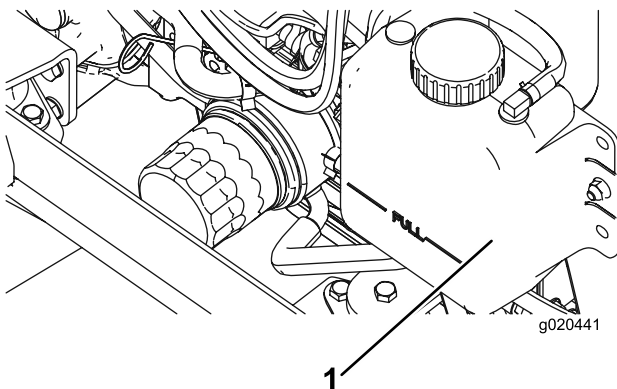

Figure 110

1. Expansion tank

3. If the coolant is low, add a 50/50 mixture of water and ethylene glycol anti-freeze.

**Important:** Do not use water only or alcohol/methanol base coolants, as this may cause damage.

4. Install the radiator cap and expansion-tank cap.

## Servicing the Engine-Cooling System

**Service Interval:** Every 100 hours

Every 2 years

**Remove debris from the oil radiator/oil cooler daily.** Clean them more frequently in dirty conditions.

This machine is equipped with a hydraulically-driven fan drive system that automatically (or manually) reverses to reduce the radiator/oil cooler and screen debris buildup. While this feature can help reduce the time required to clean radiator/oil cooler, it does not eliminate the need for routine cleaning. Periodic cleaning and inspection of the radiator/oil cooler is still required.

1. Shut off the engine, remove the key, and raise the hood.
2. Clean the engine area thoroughly of all debris.
3. Clean both sides of the radiator/oil cooler area thoroughly with compressed air (Figure 111).

**Note:** Start from the fan side and blow the debris out toward the back. Then, clean from the back side and blow toward the front. Repeat this procedure several times until all chaff and debris is removed.

**Important:** Cleaning the radiator/oil cooler with water can promote premature corrosion and damage to components.



# Brake Maintenance

## Adjusting the Service Brakes

Adjust the service brakes when there is more than 25 mm (1 inch) of free travel of the brake pedal, or when the brakes do not work effectively. Free travel is the distance the brake pedal moves before you feel braking resistance.

1. Release the locking latch from the brake pedals so that both pedals work independently of each other.
2. To reduce free travel of the brake pedals, tighten the brakes as follows:
  - A. Loosen the front nut on the threaded end of the brake cable (Figure 112).

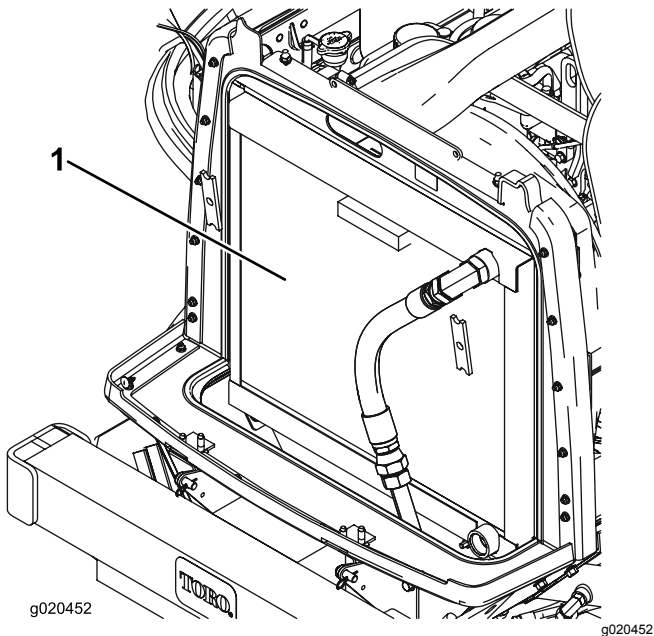

Figure 111

1. Radiator/oil cooler
- 
4. Close the hood.

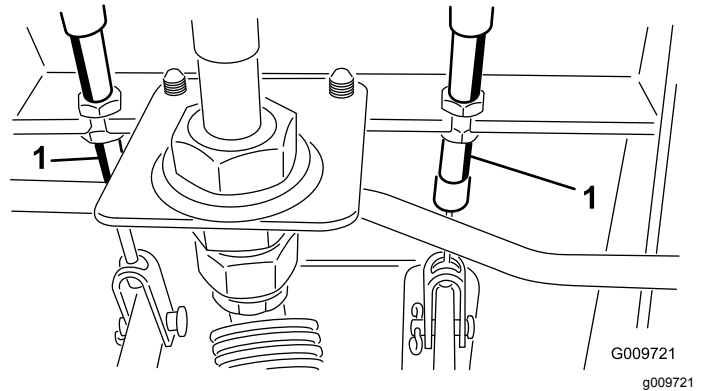

Figure 112

1. Brake cable
- 
- B. Tighten the rear nut to move the cable rearward until the brake pedals have 13 to 25 mm (1/2 to 1 inch) of free travel.
  - C. Tighten the front nuts after the brakes are adjusted correctly.

# Belt Maintenance

## Servicing the Alternator Belt

**Service Interval:** After the first 10 hours

Every 100 hours

Proper tension of the belt allows 10 mm (3/8 inch) of deflection when a force of 44 N·m (10 ft-lb) is applied on the belt midway between the pulleys.

If the deflection is not 10 mm (3/8 inch), loosen the alternator-mounting bolts (Figure 113).

**Note:** Increase or decrease the alternator-belt tension and tighten the bolts. Check the deflection of the belt again to ensure that the tension is correct.

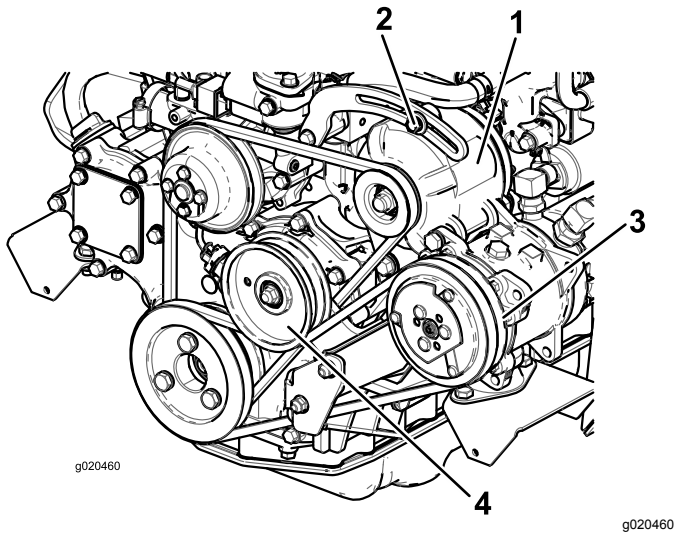

Figure 113

- |                  |                 |
|------------------|-----------------|
| 1. Alternator    | 3. Compressor   |
| 2. Mounting bolt | 4. Idler pulley |

## Servicing the Air Conditioner Compressor Belt

**Service Interval:** After the first 10 hours

Every 100 hours

**Cab model only**

Check the condition and tension of the belt (Figure 114) after every 100 operating hours.

1. Proper tension allows 10 mm (3/8 inch) deflection when a force of 44 N (10 lb) is applied on the belt midway between the pulleys.

2. If the deflection is not 10 mm (3/8 inch), loosen the idler pulley mounting bolt (Figure 113). Increase or decrease the compressor belt tension and tighten the bolt. Check the deflection of the belt again to ensure that the tension is correct.

## Tensioning the Blade-Drive Belts

**Service Interval:** After the first 10 hours

Every 50 hours

When properly tensioned, the inside measurement of the extension spring (hook to hook) should be approximately 8.3 to 9.5 cm (3-1/4 to 3-3/4 inches). Once the correct spring tension is attained, adjust the stop bolt (carriage bolt) until there is approximately 2 to 5 mm (0.065 to 0.185 inch) clearance between the head of the bolt and the idler arm (Figure 114).

**Note:** Ensure that the belt is positioned on the spring side of the belt guide (Figure 114).

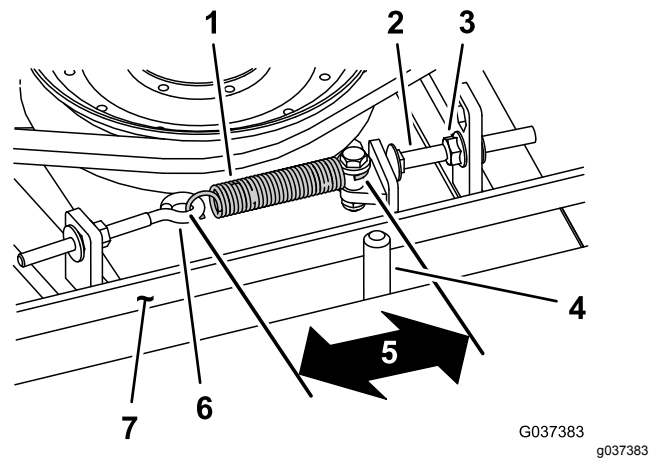

Figure 114

- |                     |   |
|---------------------|---|
| 1. Extension spring | 5. Measurement (hook to hook)—approximately 8.3 to 9.5 cm (3-1/4 to 3-3/4 inches) |
| 2. Stop bolt        | 6. Eye bolt   |
| 3. Flange nut       | 7. Belt   |
| 4. Belt guide       |   |

# Replacing the Blade-Drive Belt

**Service Interval:** Every 800 hours

The blade-drive belt, tensioned by the spring-loaded idler pulley, is very durable. However, after many hours of use, the belt will show signs of wear. Signs of a worn belt are: squealing when the belt is rotating, blades slipping when cutting grass, frayed edges, burn marks, and cracks. Replace the belt if any of these conditions are evident.

1. Lower the mower deck to the shop floor, remove the belt covers from the top of the mower deck, and set the covers aside.
2. Loosen the eye bolt (Figure 114).
3. Loosen the flange nut securing the stop bolt to the mounting tab and move the idler pulley away from the belt (Figure 114).

**Note:** Loosen the nut enough to allow the idler arm to pass the stop bolt.

**Note:** If you must remove the stop bolt from the mounting tab, install it in the hole that aligns the stop-bolt head with the idler arm.

4. Remove the bolts securing the hydraulic motor to the mower deck (Figure 115).

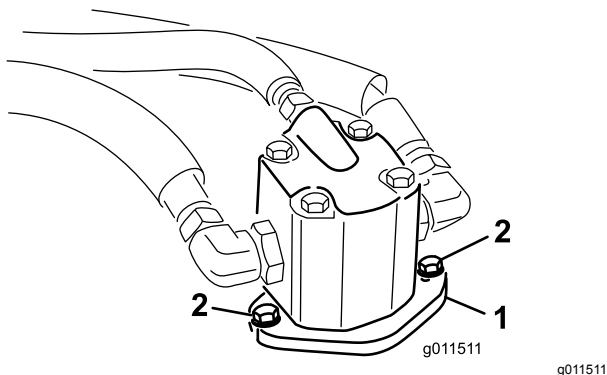

**Figure 115**

1. Hydraulic motor
2. Mounting bolts

5. Lift the motor off the mower deck and lay it on top of the mower deck.
6. Remove the old belt from around the spindle pulleys and idler pulley.
7. Route the new belt around the spindle pulleys and idler-pulley assembly.
8. Position the hydraulic motor on the mower deck after routing the belt around the pulleys. Mount the motor to the mower deck with the bolts previously removed.

**Note:** Ensure that the belt is positioned on the spring side of the belt guide (Figure 114).

9. Connect the extension spring (Figure 114) to the eye bolt and tension the belt as follows:
  - When properly tensioned, the inside measurement of the extension spring (hook to hook) should be approximately 8.3 to 9.5 cm (3-1/4 to 3-3/4 inch).
  - When you attain the correct spring tension, adjust the stop bolt (carriage bolt) until there is approximately 2 to 5 mm (0.065 to 0.185 inches) clearance between the head of the bolt and the idler arm.

# Hydraulic System Maintenance

## Hydraulic System Safety

- Seek immediate medical attention if fluid is injected into skin. Injected fluid must be surgically removed within a few hours by a doctor.
- Ensure that all hydraulic-fluid hoses and lines are in good condition and all hydraulic connections and fittings are tight before applying pressure to the hydraulic system.
- Keep your body and hands away from pinhole leaks or nozzles that eject high-pressure hydraulic fluid.
- Use cardboard or paper to find hydraulic leaks.
- Safely relieve all pressure in the hydraulic system before performing any work on the hydraulic system.

## Checking the Hydraulic Fluid

**Service Interval:** Before each use or daily

The reservoir is filled at the factory with approximately 29 L (7.75 US gallons) of high-quality hydraulic fluid. Check the level of the hydraulic fluid before the engine is first started and daily thereafter. The recommended replacement fluid is as follows:

**Toro Premium All Season Hydraulic Fluid** (Available in 19 L (5 US gallons) pails or 208 L (55 US gallons) drums. See the *Parts Catalog* or your Toro Distributor for part numbers).

Alternative fluids: If the Toro fluid is not available, other **conventional, petroleum-based** fluids may be used, provided they meet all of the following material properties and industry specifications. Check with your oil supplier to see whether the oil meets these specifications.

**Note:** Toro does not assume responsibility for damage caused by improper substitutions, so use only products from reputable manufacturers who will stand behind their recommendation.

## High Viscosity Index/Low Pour Point Anti-wear Hydraulic Fluid, ISO VG 46

Material Properties:

Viscosity, ASTM D445 St @ 40° C 44 to 50

St @ 100° C 7.9 to 8.5

Viscosity Index ASTM D2270 140 to 160

Pour Point, ASTM D97 -34° F to -49° F

Industry Specifications: Vickers I-286-S (Quality Level), Vickers M-2950-S (Quality Level), Denison HF-0

The proper hydraulic fluids must be specified for mobile machinery (as opposed to industrial plant usage), multi-weight type, with ZnDTP or ZDDP anti-wear additive package (not an ashless-type fluid).

**Toro Synthetic Biodegradable Hydraulic Fluid** (Available in 19 L (5 US gallon) pails or 208 L (55 US gallon) drums. See the *Parts Catalog* or your Toro Distributor for part numbers)

This high quality synthetic, biodegradable fluid has been tested and found compatible for this Toro model. Other brands of synthetic fluid may have seal compatibility problems and Toro cannot assume responsibility for unauthorized substitutions.

**Important:** This synthetic fluid is not compatible with the Toro Biodegradable Fluid previously sold. See your Toro Distributor for more information.

Alternative biodegradable fluids:

Mobil EAL EnviroSyn H 46 (US)

Mobil EAL Hydraulic Oil 46 (International)

**Important:** Many hydraulic fluids are almost colorless, making it difficult to spot leaks. A red dye additive for the hydraulic fluid is available in 20 ml (2/3 fl oz) bottles. 1 bottle is sufficient for 15 to 22 L (4 to 6 US gallons) of hydraulic oil. Order Part No. 44-2500 from your Toro Distributor.

1. Park the machine on a level surface, lower the mower decks, shut off the engine, and remove the key.
2. Check the hydraulic-fluid level ([Figure 116](#)).

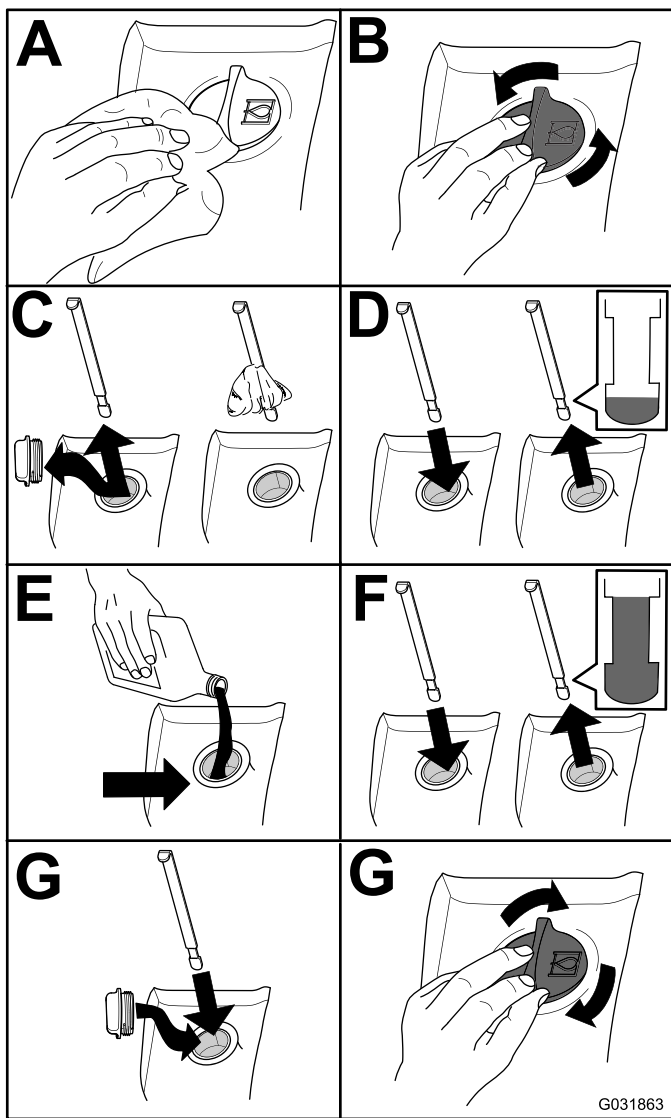

Figure 116

4. Fill the reservoir (Figure 117) with hydraulic fluid; refer to [Checking the Hydraulic Fluid](#) (page 77).

**Important:** Use only the hydraulic fluids specified. Other fluids damage the system.

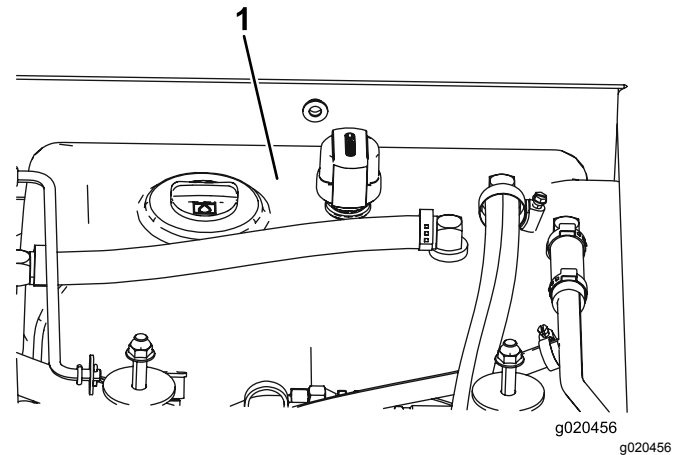

Figure 117

1. Hydraulic reservoir

5. Install the reservoir cap, start the engine, and use all the hydraulic controls to distribute hydraulic fluid throughout the system.

**Note:** Also check for leaks; then shut off the engine.

6. Check the fluid level and add enough to raise level the level to the Full mark on the dipstick.

**Note:** Do not overfill.

## Changing the Hydraulic Fluid

**Service Interval:** Every 800 hours

If the fluid becomes contaminated, contact your local Toro distributor because the system must be flushed. Contaminated fluid looks milky or black when compared to clean oil.

1. Position the machine on a level surface, lower the mower decks, shut off the engine, and remove the key from the ignition.
2. Remove the drain plug from the bottom, front of the reservoir and let the hydraulic fluid flow into a large drain pan.
3. Install and tighten the plug when the hydraulic fluid stops draining.

## Replacing the Hydraulic Filters

**Service Interval:** After the first 200 hours

Every 800 hours

Use Toro replacement filters Part No. 94-2621 for the rear (mower deck) of the machine and Part No. 75-1310 for the front (charge) of the machine.

**Important:** Use of any other filter may void the warranty on some components.

1. Park the machine on a level surface, lower the mower decks, engage the parking brake, shut off the engine, and remove the key.
2. Replace the hydraulic filters (Figure 118).

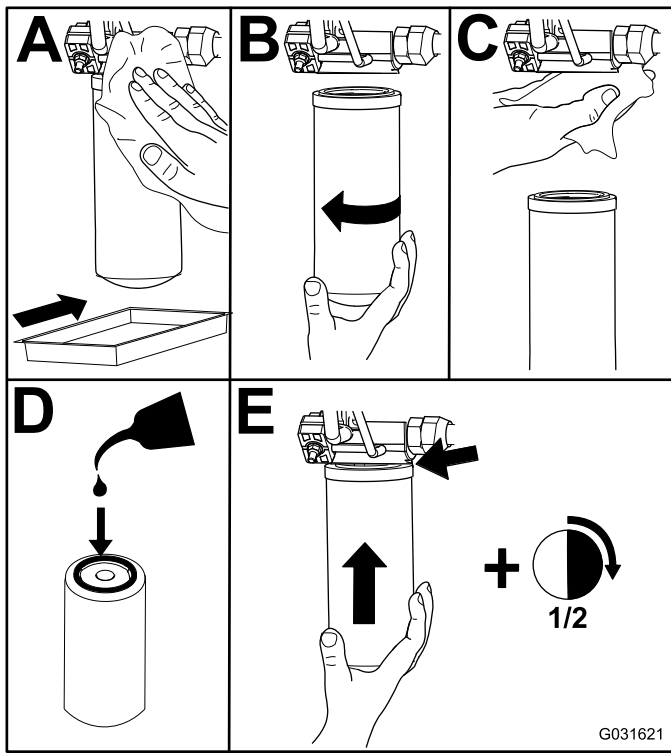

Figure 118

**Note:** The caster wheels of all 3 mower decks should remain on the ground when adjusting the counterbalance and with counterbalance applied.

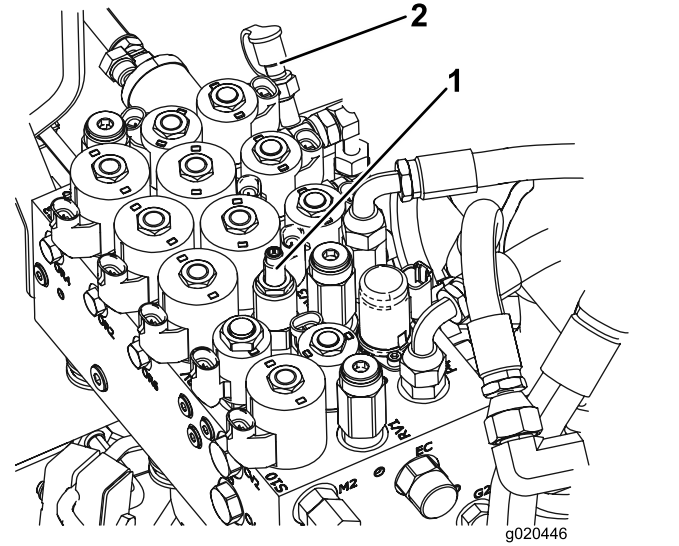

Figure 119

1. Counterbalance adjusting
2. Counterbalance test port screw

3. Start the engine and let it run for about 2 minutes to purge air from the system.
4. Shut off the engine and check for leaks.

## Checking the Hydraulic Lines and Hoses

**Service Interval:** Every 2 years

Inspect the hydraulic lines and hoses daily for leaks, kinked lines, loose mounting supports, wear, loose fittings, weather deterioration, and chemical deterioration. Make all necessary repairs before operating.

## Adjusting the Counterbalance Pressure

The counterbalance test port is used to test the pressure in the counterbalance circuit (Figure 119). The recommended counterbalance pressure is 2241 kPa (325 psi). To adjust the counterbalance pressure, loosen the locknut, rotate the adjusting screw (Figure 119) clockwise to increase the pressure or counterclockwise to decrease the pressure, and tighten the locknut. The engine must be running and the deck lowered and in the float position to check the pressure.



# Cutting Unit Maintenance

## Pivoting (Tilting) the Center Mower Deck to the Upright Position

**Note:** Although not needed, you can pivot (tilt) the center mower deck.

1. Raise the center mower deck slightly off the floor, set the parking brake, and shut off the engine, and remove the key.
2. Remove the hairpin cotter securing the dampers to lift arms (Figure 120).

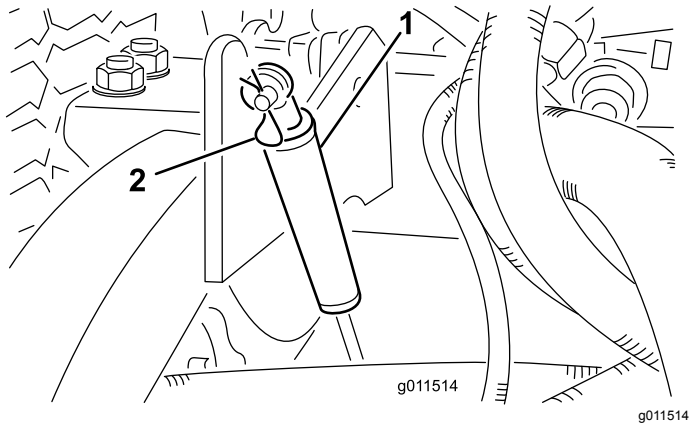

Figure 120

1. Damper
2. Hairpin cotter

3. Pivot the damper toward the deck housing.
4. Remove the hairpin cotter and clevis pin securing the height-of-cut chains to the rear of the mower deck (Figure 121).

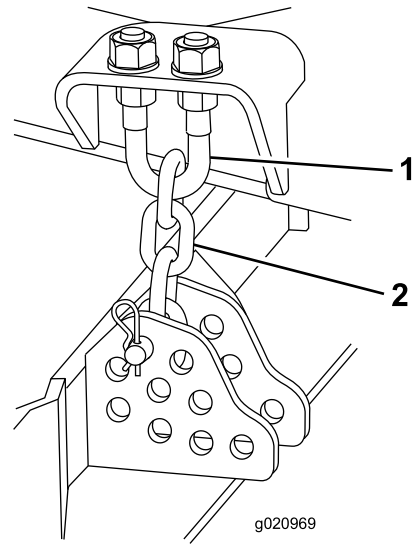

Figure 121

1. U-bolt
2. Height-of-cut chain

5. Start the engine and slowly raise the center mower deck.
6. Slowly raise each side cutting until the center of gravity shifts and the deck starts to rotate into the upright position.
7. Shut off the engine and remove the ignition key.

## Pivoting the Center Mower Deck Down

1. Slowly lower the wing mower decks until the center of gravity shifts and the center mower deck rotates downward.
2. Sit on the seat, start the engine, and lower the center mower deck until it is slightly off the floor.
3. Shut off the engine, wait for all parts to stop moving, and remove the key.
4. Secure the height-of-cut chains to the rear of the mower deck.
5. Pivot the dampers upward into position and secure with a clevis pin and cotter pin.

# Adjusting the Mower-Deck Pitch

## Measuring the Mower-Deck Pitch

Mower-deck pitch is the difference in height-of-cut from the front of the blade plane to the back of the blade plane. Use a blade pitch of 8 to 11 mm (5/16 to 7/16 inch). That is the back of the blade plane is 8 to 11 mm (5/16 to 7/16 inch) higher than the front.

1. Position the machine on a level surface on the shop floor.
2. Set the mower deck to the desired height of cut.
3. Rotate a blade to point straight forward.
4. Using a short ruler, measure from the floor to the front tip of the blade.
5. Rotate the blade tip to the rear and measure from the floor to the tip of the blade.
6. Subtract the front dimension from the rear dimension to calculate the blade pitch.

## Adjusting the Center Mower-Deck Pitch

1. Loosen the jam nuts on the top or bottom of the height-of-cut-chain U-bolt (Figure 122).
2. Adjust the other set of nuts to raise or lower the rear of the mower deck and attain the correct mower-deck pitch.
3. Tighten the jam nuts.

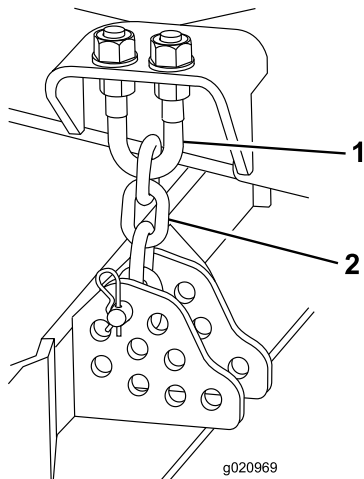

Figure 122

1. U-bolt
2. Height-of-cut chain

# Adjusting the Wing Mower Decks

1. Remove the cap screws and nuts securing the caster arm to the caster fork (Figure 123).
2. Position the shims, as required, to raise or lower the caster wheel until the mower deck has the correct pitch.
3. Install the cap screws and nuts.

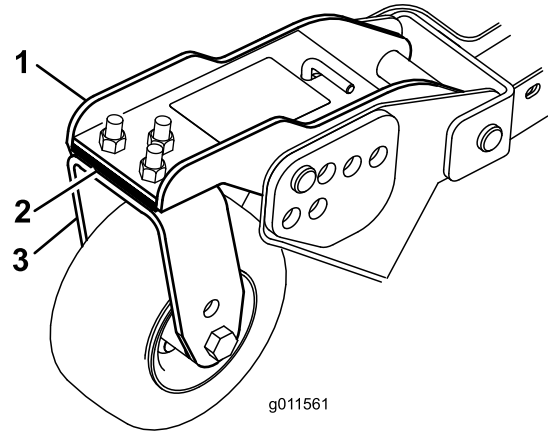

Figure 123

1. caster arm
2. Shims
3. caster fork

# Servicing the Caster-Arm Bushings

## Removing the Bushings

The caster arms have bushings pressed into the top and bottom of the tube and after many hours of operation, the bushings develop wear. To check the bushings, move the caster fork back and forth and from side to side. If the caster spindle is loose inside the bushings, replace the bushings.

1. Raise the mower deck so that the wheels are off the floor and block the mower deck so it cannot fall.
2. Remove the tensioning cap, spacer(s), and thrust washer from the top of the caster spindle.
3. Pull the caster spindle out of the mounting tube.

**Note:** Keep the thrust washer and spacer(s) on the bottom of the spindle.

4. Insert a pin punch into the top or bottom of the mounting tube and drive the bushing out of the tube (Figure 124).



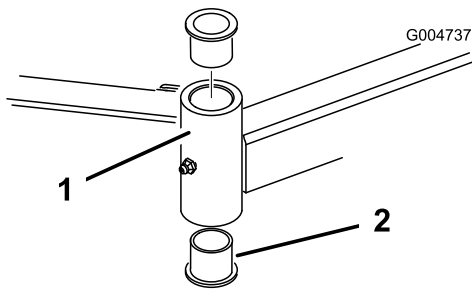

**Figure 124**

g004737

- |                    |             |
|--------------------|-------------|
| 1. Caster-arm tube | 2. Bushings |
|--------------------|-------------|

5. Drive the other bushing out of the tube.
6. Clean the inside of the tubes to remove dirt.

## Installing the Bushings

1. Apply grease to the inside and outside of the new bushings.
2. Using a hammer and flat plate, drive the bushings into the mounting tube.
3. Inspect the caster spindle for wear and replace it if it is damaged.
4. Push the caster spindle through the bushings and mounting tube.
5. Slide the thrust washer and spacer(s) onto the spindle and install the tensioning cap on the caster spindle to retain all parts in place.

# Servicing the Caster Wheels and Bearings

**Service Interval:** Every 800 hours

1. Remove the locknut from the bolt holding the caster-wheel assembly between the caster fork (Figure 125) or the caster-pivot arm (Figure 126).

**Note:** Grasp the caster wheel and slide the bolt out of the fork or pivot arm.

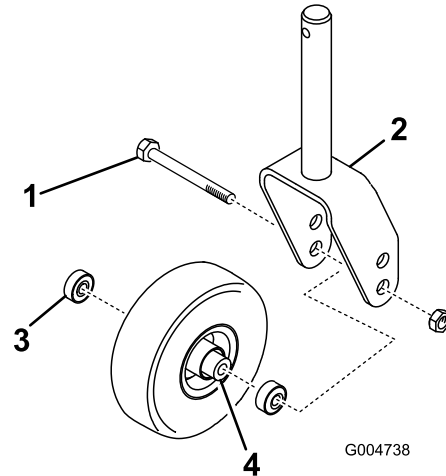

**Figure 125**

g004738

- |                |                   |
|----------------|-------------------|
| 1. Caster bolt | 3. Bearing        |
| 2. Caster fork | 4. Bearing spacer |

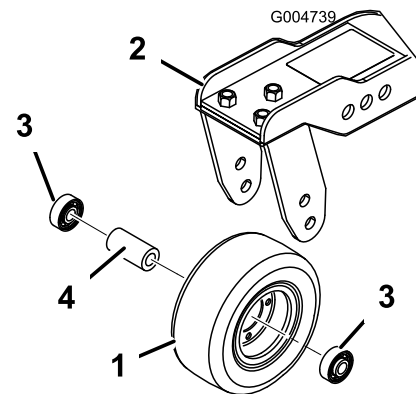

**Figure 126**

g004739

- |                     |                   |
|---------------------|-------------------|
| 1. Caster wheel     | 3. Bearing        |
| 2. Caster-pivot arm | 4. Bearing spacer |

2. Remove the bearing from the wheel hub and allow the bearing spacer to fall out (Figure 125 and Figure 126).
3. Remove the bearing from the opposite side of the wheel hub.

4. Check the bearings, spacer, and inside of the wheel hub for wear and replace any damaged parts.
5. To assemble the caster wheel, push the bearing into the wheel hub.

**Note:** When installing the bearings, press on the outer face of the bearing.

6. Slide the bearing spacer into the wheel hub and push the other bearing into the open end of the wheel hub to captivate the bearing spacer inside the wheel hub.
7. Install the caster-wheel assembly between the caster fork and secure it in place with the bolt and locknut.

## Replacing the Mower-Deck-Hinge Covers

The hinge cover prevents debris from escaping at hinge points between mower decks. If the cover(s) become damaged or worn, replace them.

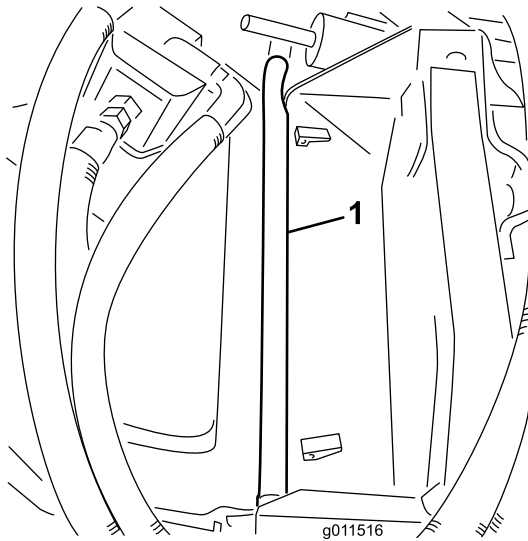

Figure 127

## Blade Maintenance

### Blade Safety

A worn or damaged blade can break, and a piece of the blade could be thrown toward you or bystanders, resulting in serious personal injury or death.

- Inspect the blade periodically for wear or damage.
- Use care when checking the blades. Wrap the blades or wear gloves, and use caution when servicing the blades. Only replace or sharpen the blades; never straighten or weld them.
- On multi-bladed machines, take care as rotating 1 blade can cause other blades to rotate.

### Checking for a Bent Blade

After striking a foreign object, inspect the machine for damage and make repairs before starting and operating the equipment. Torque all of the spindle-pulley nuts to 176 to 203 N·m (130 to 150 ft·lb).

1. Position the machine on a level surface, raise the mower deck, engage the parking brake, put the traction pedal in NEUTRAL, put the PTO lever in the OFF position, shut off the engine, and remove the ignition key.

**Note:** Block the mower deck to prevent it from accidentally falling.

2. Rotate the blade until the ends face forward and backward and measure from the inside of the mower deck to the cutting edge at the front of the blade (Figure 128).

**Note:** Remember this dimension.

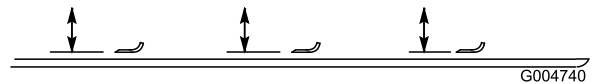

Figure 128

3. Rotate the opposite end of the blade forward and measure between the mower deck and cutting edge of the blade at the same position as in step 2.

**Note:** The difference between the dimensions obtained in steps 2 and 3 must not exceed 3 mm (1/8 inch). If the dimension exceeds 3 mm (1/8 inch), the blade is bent and must be replaced; refer to [Removing and Installing the Mower Blade\(s\)](#) (page 84).

# Removing and Installing the Mower Blade(s)

Replace the blade if it hits a solid object, is out of balance, or if it is bent. Always use genuine Toro replacement blades to ensure safety and optimum performance.

1. Raise the mower deck to the highest position, engage the parking brake, shut off the engine, and remove the key.

**Note:** Block the mower deck to prevent it from accidentally falling.

2. Grasp the end of the blade using a rag or thickly padded glove.
3. Remove the blade bolt, anti-scalp cup, and blade from the spindle shaft (Figure 129).

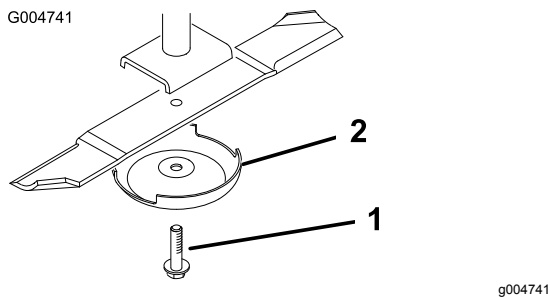

Figure 129

1. Blade bolt
2. Anti-scalp cup

4. Install the blade, anti-scalp cup, and blade bolt and tighten the blade bolt to 115 to 149 N·m (85 to 110 ft-lb).

**Important:** The curved part of the blade must be pointing toward the inside of the mower deck to ensure proper cutting.

**Note:** After striking a foreign object, torque all of the spindle-pulley nuts to 115 to 149 N·m (85 to 110 ft-lb).

# Inspecting and Sharpening the Mower Blade(s)

Both cutting edges and the sail, which is the turned-up portion opposite of the cutting edge, contribute to a good quality of cut. The sail lifts the grass up straight, thereby producing an even cut. However, the sail gradually wears down during operation degrading the quality of cut, although the cutting edges are sharp. The cutting edge of the blade must be sharp so that the grass is cut rather than torn, which leaves the tips of the grass looking brown and shredded. Sharpen the cutting edges to correct this condition.

1. Position the machine on a level surface, raise the mower deck, engage the parking brake, put the traction pedal in NEUTRAL, put the PTO lever in the OFF position, shut off the engine, and remove the key from the ignition.
2. Examine the cutting ends of the blade carefully, especially where the flat and curved parts of the blade meet (Figure 130).

**Note:** Because sand and abrasive material can wear away the metal that connects the flat and curved parts of the blade, check the blade before using the mower. If you notice wear (Figure 130), replace the blade.

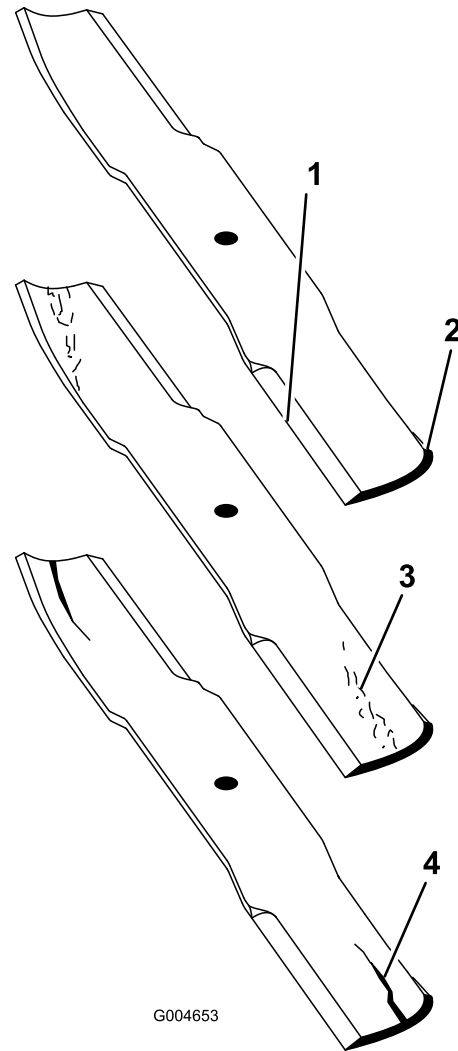

Figure 130

1. Cutting edge
2. Curved area
3. Wear/slot forming
4. Crack

3. Examine the cutting edges of all of the blades and sharpen the cutting edges if they are dull or nicked (Figure 131).

**Note:** Sharpen only the top of the cutting edge and maintain the original cutting angle

to ensure sharpness (Figure 131). The blade remains balanced if the same amount of metal is removed from both cutting edges.

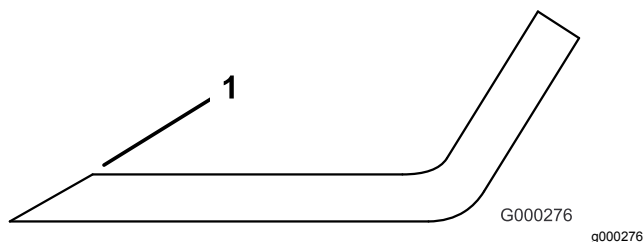

**Figure 131**

1. Sharpen at the original angle.

---

**Note:** Remove the blades and sharpen them on a grinder. After sharpening the cutting edges, install the blade with the anti-scalp cup and blade bolt; refer to [Removing and Installing the Mower Blade\(s\)](#) (page 84).

## Correcting a Mower-Deck Mismatch

When there is mismatch between the blades on a single mower deck, the grass appears streaked when it is cut. You can correct this problem by ensuring that the blades are straight.

1. Park the machine on a level surface.
2. Raise the height of cut to the highest position; refer to [Adjusting the Height of Cut](#) (page 26).
3. Lower the mower deck onto the flat surface and remove the covers from the top of the mower deck.
4. Loosen the flange nut that secures the idler pulley to release the belt tension.
5. Rotate the blades until the ends face forward and rearward and measure from the floor to the front tip of the cutting edge. Remember this dimension.
6. Rotate the same blade so that the opposite end is forward, and measure again. The difference between the dimensions must not exceed 3 mm (1/8 inch). If the dimension exceeds 3 mm (1/8 inch), replace the blade, as it is bent. Measure all the blades.
7. Compare the measurements of the outer blades with the center blade.

**Note:** The center blade must not be more than 10 mm (3/8 inch) lower than the outer blades. If the center blade is more than 10 mm (3/8 inch) lower than the outer blades, proceed to step 8 and add shims between the spindle housing and the bottom of the mower deck.

8. Remove the bolts, flat washers, lock washers, and nuts from the outer spindle in the area where you must add the shims.

**Note:** To raise or lower the blade, add a shim (Part No. 3256-24) between the spindle housing and the bottom of the mower deck. Continue to check the alignment of the blades and add shims until the tips of the blades are within the required dimension.

**Important:** Do not use more than 3 shims at any 1 hole location. Use decreasing numbers of shims in adjacent holes if more than 1 shim is added to any 1 hole location.

9. Adjust the idler pulley and install the belt covers.

# Cab Maintenance

## Cleaning the Cab

**Important:** Use care around the cab seals and lights (Figure 132). If you are using a pressure washer, keep the washer wand at least 0.6 m (2 ft) away from the machine. Do not use the pressure washer directly on the cab seals and lights or under the rear overhang.

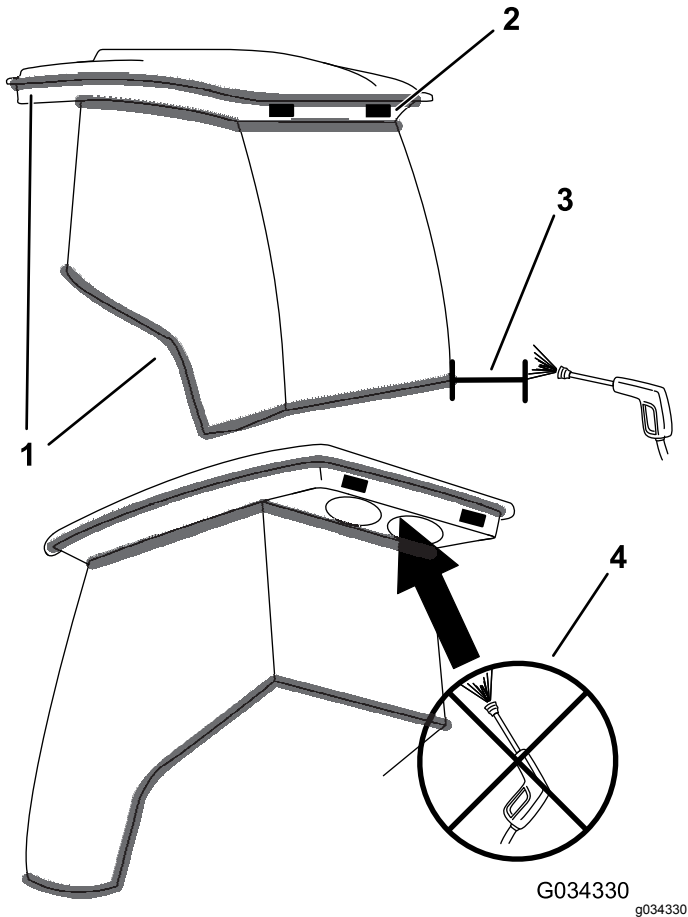

**Figure 132**

- |          |  |
|----------|--|
| 1. Seal  | 3. Keep wand 0.6 m (2 ft) away.                  |
| 2. Light | 4. Do not pressure-wash under the rear overhang. |

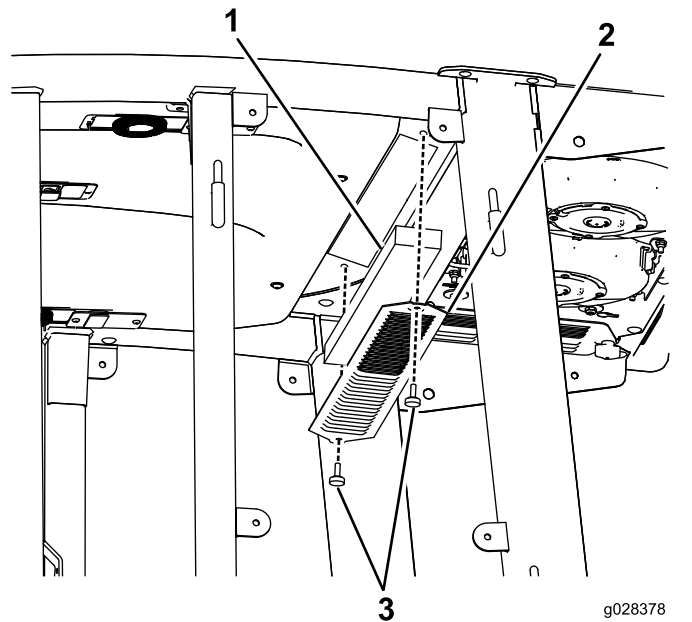

**Figure 133**  
In-Cab Air Filter

- |           |          |
|-----------|----------|
| 1. Filter | 3. Screw |
| 2. Grate  |          |

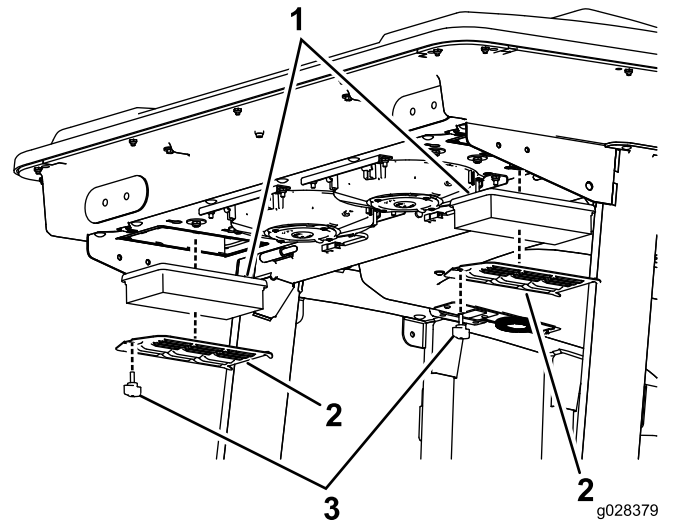

**Figure 134**  
Rear Cab Air Filter

- |           |          |
|-----------|----------|
| 1. Filter | 3. Screw |
| 2. Grate  |          |

## Cleaning the Cab Air Filters

**Service Interval:** Every 250 hours

1. Remove the screws and grates from both the in-cab and rear cab air filters (Figure 133 and Figure 134).

2. Clean the filters by blowing clean, oil-free, compressed air through them.

**Important:** If either filter has a hole, tear, or other damage, replace the filter.

3. Install the filters and the grate with the thumbscrews.

# Cleaning the Cab Pre-Filter

The cab pre-filter prevents large debris, such as grass and leaves, from entering the cab filters.

1. Rotate the screen cover down.
2. Clean the filter with water.

**Important:** Do not use a pressure washer.

**Note:** If the filter has a hole, tear, or other damage, replace the filter.

3. Allow the pre-filter to dry before installing it into the machine.
4. Rotate the filter screen around the tabs until the latch locks into the latch-mount assembly (Figure 135).

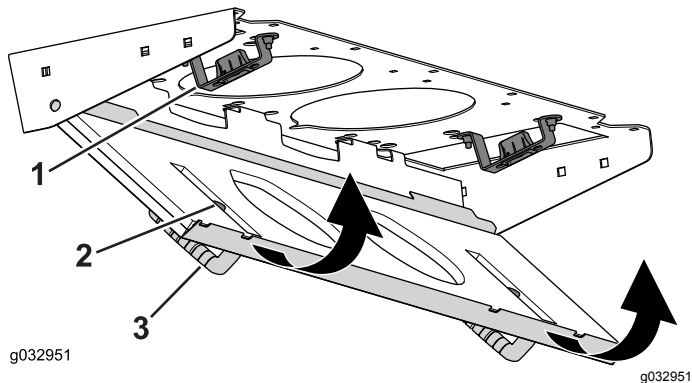

**Figure 135**

1. Latch-mount assembly
2. Latch
3. Screen cover

# Cleaning the Air-Conditioning Coil

**Service Interval:** Every 250 hours (Clean more frequently in extremely dusty or dirty conditions)

1. Shut off the engine and remove the key.
2. Remove the 6 nuts and washers from the bottom of the rear of the cab (Figure 136).

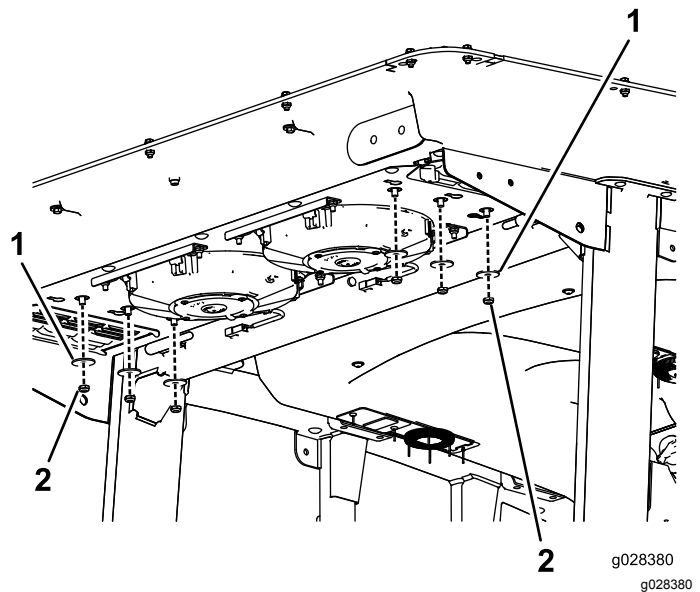

**Figure 136**

1. Washer
2. Nut

3. Remove the cabin roof of the cab by removing the 22 bolts that secure the roof (Figure 137).

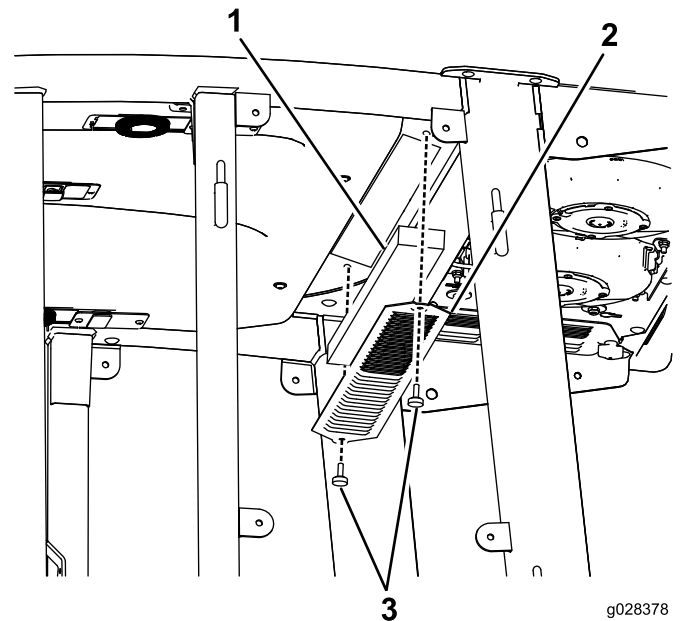

**Figure 137**

1. Cabin roof
2. Air filters
3. Air-conditioning coils

4. Remove the air filters (Figure 137).
5. Remove and clean the air-conditioning coils (Figure 137).
6. Replace the air-conditioning coils, air filters and cabin roof.

# Storage

## Preparing the Traction Unit

1. Shut off the engine and remove the key.
2. Thoroughly clean the traction unit, mower decks, and the engine.

**Important:** Do not use high-pressure water near the Info Center or engine-control unit (ECU), as this may cause damage.

3. Check the tire pressure; refer to [Checking the Tire Pressure \(page 23\)](#).
4. Check all fasteners for looseness; tighten as necessary.
5. Grease or oil all grease fittings and pivot points and wipe up any excess lubricant; refer to [Lubrication \(page 61\)](#).
6. Lightly sand and use touch-up paint on painted areas that are scratched, chipped, or rusted, and repair any dents in the metal body.
7. Service the battery and cables as follows:
  - A. Remove the battery terminals from the battery posts.
  - B. Clean the battery, terminals, and posts with a wire brush and baking-soda solution.
  - C. Coat the cable terminals and battery posts with Grafo 112X skin-over grease (Toro Part No. 505-47) or petroleum jelly to prevent corrosion.
  - D. Slowly charge the battery every 60 days for 24 hours to prevent lead sulfation of the battery.

10. Check the anti-freeze protection and add a 50/50 solution of water and ethylene glycol anti-freeze as needed for the expected minimum temperature in your area.

## Preparing the Engine

1. Drain the engine oil from the oil pan and install the drain plug.
2. Remove and install a new oil filter.
3. Fill engine with 10.4 L (11 US qt) of SAE 15W-40 CJ-4 motor oil.
4. Start the engine and run it at idle speed for approximately 2 minutes.
5. Shut off the engine.
6. Flush the fuel tank with fresh, clean fuel.
7. Secure all of the fuel-system fittings.
8. Thoroughly clean and service the air-cleaner assembly.
9. Seal the air-cleaner inlet and the exhaust outlet with weatherproof tape.

**Notes:**



## **European Privacy Notice**

### **The Information Toro Collects**

Toro Warranty Company (Toro) respects your privacy. In order to process your warranty claim and contact you in the event of a product recall, we ask you to share certain personal information with us, either directly or through your local Toro company or dealer.

The Toro warranty system is hosted on servers located within the United States where privacy law may not provide the same protection as applies in your country.

**BY SHARING YOUR PERSONAL INFORMATION WITH US, YOU ARE CONSENTING TO THE PROCESSING OF YOUR PERSONAL INFORMATION AS DESCRIBED IN THIS PRIVACY NOTICE.**

### **The Way Toro Uses Information**

Toro may use your personal information to process warranty claims, to contact you in the event of a product recall and for any other purpose which we tell you about. Toro may share your information with Toro's affiliates, dealers or other business partners in connection with any of these activities. We will not sell your personal information to any other company. We reserve the right to disclose personal information in order to comply with applicable laws and with requests by the appropriate authorities, to operate our systems properly or for our own protection or that of other users.

### **Retention of your Personal Information**

We will keep your personal information as long as we need it for the purposes for which it was originally collected or for other legitimate purposes (such as regulatory compliance), or as required by applicable law.

### **Toro's Commitment to Security of Your Personal Information**

We take reasonable precautions in order to protect the security of your personal information. We also take steps to maintain the accuracy and current status of personal information.

### **Access and Correction of your Personal Information**

If you would like to review or correct your personal information, please contact us by email at [legal@toro.com](mailto:legal@toro.com).

## **Australian Consumer Law**

Australian customers will find details relating to the Australian Consumer Law either inside the box or at your local Toro Dealer.

# California Proposition 65 Warning Information

## What is this warning?

You may see a product for sale that has a warning label like the following:



**WARNING: Cancer and Reproductive Harm—[www.p65Warnings.ca.gov](http://www.p65Warnings.ca.gov).**

## What is Prop 65?

Prop 65 applies to any company operating in California, selling products in California, or manufacturing products that may be sold in or brought into California. It mandates that the Governor of California maintain and publish a list of chemicals known to cause cancer, birth defects, and/or other reproductive harm. The list, which is updated annually, includes hundreds of chemicals found in many everyday items. The purpose of Prop 65 is to inform the public about exposure to these chemicals.

Prop 65 does not ban the sale of products containing these chemicals but instead requires warnings on any product, product packaging, or literature with the product. Moreover, a Prop 65 warning does not mean that a product is in violation of any product safety standards or requirements. In fact, the California government has clarified that a Prop 65 warning "is not the same as a regulatory decision that a product is 'safe' or 'unsafe.'" Many of these chemicals have been used in everyday products for years without documented harm. For more information, go to <https://oag.ca.gov/prop65/faqs-view-all>.

A Prop 65 warning means that a company has either (1) evaluated the exposure and has concluded that it exceeds the "no significant risk level"; or (2) has chosen to provide a warning based on its understanding about the presence of a listed chemical without attempting to evaluate the exposure.

## Does this law apply everywhere?

Prop 65 warnings are required under California law only. These warnings are seen throughout California in a wide range of settings, including but not limited to restaurants, grocery stores, hotels, schools, and hospitals, and on a wide variety of products. Additionally, some online and mail order retailers provide Prop 65 warnings on their websites or in catalogs.

## How do the California warnings compare to federal limits?

Prop 65 standards are often more stringent than federal and international standards. There are various substances that require a Prop 65 warning at levels that are far lower than federal action limits. For example, the Prop 65 standard for warnings for lead is 0.5 µg/day, which is well below the federal and international standards.

## Why don't all similar products carry the warning?

- Products sold in California require Prop 65 labelling while similar products sold elsewhere do not.
- A company involved in a Prop 65 lawsuit reaching a settlement may be required to use Prop 65 warnings for its products, but other companies making similar products may have no such requirement.
- The enforcement of Prop 65 is inconsistent.
- Companies may elect not to provide warnings because they conclude that they are not required to do so under Prop 65; a lack of warnings for a product does not mean that the product is free of listed chemicals at similar levels.

## Why does Toro include this warning?

Toro has chosen to provide consumers with as much information as possible so that they can make informed decisions about the products they buy and use. Toro provides warnings in certain cases based on its knowledge of the presence of one or more listed chemicals without evaluating the level of exposure, as not all the listed chemicals provide exposure limit requirements. While the exposure from Toro products may be negligible or well within the "no significant risk" range, out of an abundance of caution, Toro has elected to provide the Prop 65 warnings. Moreover, if Toro does not provide these warnings, it could be sued by the State of California or by private parties seeking to enforce Prop 65 and subject to substantial penalties.



# The Toro Warranty

## A Two-Year Limited Warranty

### Conditions and Products Covered

The Toro Company and its affiliate, Toro Warranty Company, pursuant to an agreement between them, jointly warrant your Toro Commercial product ("Product") to be free from defects in materials or workmanship for two years or 1500 operational hours\*, whichever occurs first. This warranty is applicable to all products with the exception of Aerators (refer to separate warranty statements for these products). Where a warrantable condition exists, we will repair the Product at no cost to you including diagnostics, labor, parts, and transportation. This warranty begins on the date the Product is delivered to the original retail purchaser.

\* Product equipped with an hour meter.

### Instructions for Obtaining Warranty Service

You are responsible for notifying the Commercial Products Distributor or Authorized Commercial Products Dealer from whom you purchased the Product as soon as you believe a warrantable condition exists. If you need help locating a Commercial Products Distributor or Authorized Dealer, or if you have questions regarding your warranty rights or responsibilities, you may contact us at:

Toro Commercial Products Service Department  
Toro Warranty Company  
8111 Lyndale Avenue South  
Bloomington, MN 55420-1196  
952-888-8801 or 800-952-2740  
E-mail: commercial.warranty@toro.com

### Owner Responsibilities

As the Product owner, you are responsible for required maintenance and adjustments stated in your *Operator's Manual*. Failure to perform required maintenance and adjustments can be grounds for disallowing a warranty claim.

### Items and Conditions Not Covered

Not all product failures or malfunctions that occur during the warranty period are defects in materials or workmanship. This warranty does not cover the following:

- Product failures which result from the use of non-Toro replacement parts, or from installation and use of add-on, or modified non-Toro branded accessories and products. A separate warranty may be provided by the manufacturer of these items.
- Product failures which result from failure to perform recommended maintenance and/or adjustments. Failure to properly maintain your Toro product per the Recommended Maintenance listed in the *Operator's Manual* can result in claims for warranty being denied.
- Product failures which result from operating the Product in an abusive, negligent, or reckless manner.
- Parts subject to consumption through use unless found to be defective. Examples of parts which are consumed, or used up, during normal Product operation include, but are not limited to, brake pads and linings, clutch linings, blades, reels, rollers and bearings (sealed or greasable), bed knives, spark plugs, castor wheels and bearings, tires, filters, belts, and certain sprayer components such as diaphragms, nozzles, and check valves, etc.
- Failures caused by outside influence. Conditions considered to be outside influence include, but are not limited to, weather, storage practices, contamination, use of unapproved fuels, coolants, lubricants, additives, fertilizers, water, or chemicals, etc.
- Failure or performance issues due to the use of fuels (e.g. gasoline, diesel, or biodiesel) that do not conform to their respective industry standards.

### Countries Other than the United States or Canada

Customers who have purchased Toro products exported from the United States or Canada should contact their Toro Distributor (Dealer) to obtain guarantee policies for your country, province, or state. If for any reason you are dissatisfied with your Distributor's service or have difficulty obtaining guarantee information, contact the Toro importer.

- Normal noise, vibration, wear and tear, and deterioration.
- Normal "wear and tear" includes, but is not limited to, damage to seats due to wear or abrasion, worn painted surfaces, scratched decals or windows, etc.

### Parts

Parts scheduled for replacement as required maintenance are warranted for the period of time up to the scheduled replacement time for that part. Parts replaced under this warranty are covered for the duration of the original product warranty and become the property of Toro. Toro will make the final decision whether to repair any existing part or assembly or replace it. Toro may use remanufactured parts for warranty repairs.

### Deep Cycle and Lithium-Ion Battery Warranty:

Deep cycle and Lithium-Ion batteries have a specified total number of kilowatt-hours they can deliver during their lifetime. Operating, recharging, and maintenance techniques can extend or reduce total battery life. As the batteries in this product are consumed, the amount of useful work between charging intervals will slowly decrease until the battery is completely worn out. Replacement of worn out batteries, due to normal consumption, is the responsibility of the product owner. Battery replacement may be required during the normal product warranty period at owner's expense. Note: (Lithium-Ion battery only): A Lithium-Ion battery has a part only prorated warranty beginning year 3 through year 5 based on the time in service and kilowatt hours used. Refer to the *Operator's Manual* for additional information.

### Maintenance is at Owner's Expense

Engine tune-up, lubrication, cleaning and polishing, replacement of filters, coolant, and completing recommended maintenance are some of the normal services Toro products require that are at the owner's expense.

### General Conditions

Repair by an Authorized Toro Distributor or Dealer is your sole remedy under this warranty.

**Neither The Toro Company nor Toro Warranty Company is liable for indirect, incidental or consequential damages in connection with the use of the Toro Products covered by this warranty, including any cost or expense of providing substitute equipment or service during reasonable periods of malfunction or non-use pending completion of repairs under this warranty. Except for the Emissions warranty referenced below, if applicable, there is no other express warranty. All implied warranties of merchantability and fitness for use are limited to the duration of this express warranty.**

Some states do not allow exclusions of incidental or consequential damages, or limitations on how long an implied warranty lasts, so the above exclusions and limitations may not apply to you. This warranty gives you specific legal rights, and you may also have other rights which vary from state to state.

### Note regarding engine warranty:

The Emissions Control System on your Product may be covered by a separate warranty meeting requirements established by the U.S. Environmental Protection Agency (EPA) and/or the California Air Resources Board (CARB). The hour limitations set forth above do not apply to the Emissions Control System Warranty. Refer to the Engine Emission Control Warranty Statement supplied with your product or contained in the engine manufacturer's documentation for details