



Count on it.

Operator's Manual

**8-Blade Radial Reel, 8-Blade
Forward Swept Reel, or 11-Blade
Forward Swept Reel DPA Cutting
Unit with 7in Reel**

Reelmaster® 5010-H Series Traction Unit

Model No. 03638—Serial No. 40000000 and Up

Model No. 03639—Serial No. 40000000 and Up

Model No. 03641—Serial No. 40000000 and Up



⚠ WARNING

**CALIFORNIA
Proposition 65 Warning**

This product contains a chemical or chemicals known to the State of California to cause cancer, birth defects, or reproductive harm.

This product complies with all relevant European directives. For details, please see the Declaration of Incorporation (DOI) at the back of this publication.

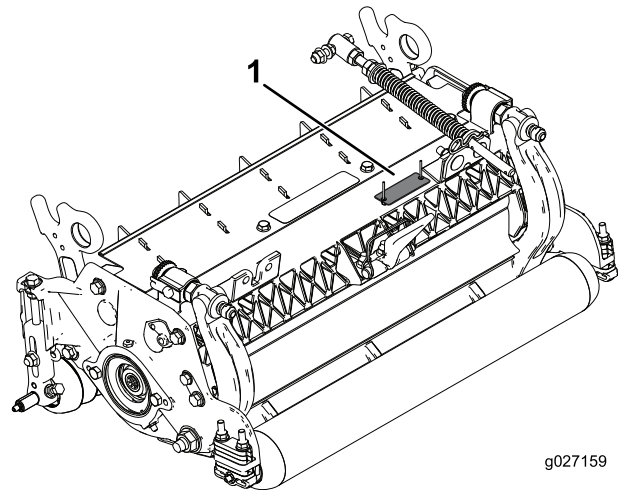

g027159

g027159

Figure 1

1. Location of the model and serial numbers

Introduction

Important: To maximize the safety, performance, and proper operation of this machine, carefully read and fully understand the contents of this *Operator's Manual*. Failing to follow these operating instructions or to receive proper training may result in injury. For more information on safe operating practices, including safety tips and training materials, go to www.Toro.com.

Read this information carefully to learn how to operate and maintain your product properly and to avoid injury and product damage. You are responsible for operating the product properly and safely.

You may contact Toro directly at www.Toro.com for product safety and operation training materials, accessory information, help finding a dealer, or to register your product.

Whenever you need service, genuine Toro parts, or additional information, contact an authorized Toro distributor or Toro Customer Service and have the model and serial numbers of your product ready. [Figure 1](#) identifies the location of the model and serial numbers on the product. Write the numbers in the space provided.

Model No. _____
Serial No. _____

This manual identifies potential hazards and has safety messages identified by the safety-alert symbol (Figure 2), which signals a hazard that may cause serious injury or death if you do not follow the recommended precautions.



Figure 2

g000502

1. Safety-alert symbol

This manual uses 2 words to highlight information. **Important** calls attention to special mechanical information and **Note** emphasizes general information worthy of special attention.

Contents

Safety	3
Safety and Instructional Decals	4
Setup	5
1 Inspecting the Cutting Unit	5
2 Using the Kickstand	5
3 Adjusting the Rear Shield.....	6
4 Installing the Loose Parts.....	6
Product Overview	8
Specifications	8
Attachments/Accessories	8
Operation	8
Making Adjustments	8
Height-of-Cut Chart Terms.....	10
Maintenance	16
Lubricating the Cutting Units.....	16
Relief-Grinding the Reel	16
Servicing the Bedknife.....	17
Servicing the Bedbar	18
Servicing the HD Dual Point Adjusters (DPA).....	20
Servicing the Roller.....	22

Safety

This machine has been designed in accordance with EN ISO 5395:2013.

Improper use or maintenance of this equipment can result in injury or death. To reduce the potential for injury or death, comply with the following safety instructions.

- Read, understand, and follow all instructions in this *Operator's Manual* before operating the cutting unit.
- Lower the cutting units to the ground, engage the parking brake, shut off the engine, and remove the key from the ignition switch whenever you leave the machine unattended.
- Be sure that the cutting units are in safe operating condition by keeping nuts, bolts, and screws tight.

Safety and Instructional Decals



Safety decals and instructions are easily visible to the operator and are located near any area of potential danger. Replace any decal that is damaged or missing.



decal93-6688

93-6688

1. Warning—read the instructions before servicing or performing maintenance.
 2. Cutting hazard of hand or foot—shut off the engine and wait for moving parts to stop.
-

Setup

Loose Parts

Use the chart below to verify that all parts have been shipped.

Procedure	Description	Qty.	Use
1	Cutting unit	1	Inspect the cutting unit.
2	No parts required	–	Use the kickstand when tipping the cutting unit.
3	No parts required	–	Adjust the rear shield.
4	Straight grease fitting O-ring	1 1	Install the loose parts.

Media and Additional Parts

Description	Qty.	Use
Operator's Manual	1	Review the material and save it in an appropriate place.
Parts Catalog (not included)—refer to the included postcard for information on obtaining the Parts Catalog	–	

Note: Determine the left and right sides of the machine from the normal operating position.



Inspecting the Cutting Unit

Parts needed for this procedure:

1	Cutting unit
---	--------------

Procedure

After the cutting unit is removed from the box, inspect the following:

1. Check each end of the reel for grease.
Note: Grease should be visibly evident in the internal splines of the reel shaft.
2. Ensure that all nuts and bolts are securely tightened.
3. Make sure that the carrier-frame suspension operates freely and does not bind when moved back and forth.



Using the Kickstand

No Parts Required

Procedure

Whenever the cutting unit has to be tipped to expose the bedknife/reel, prop up the rear of the cutting unit with the kickstand (supplied with the traction unit) to make sure that the nuts on the back end of the bedbar adjusting screws are not resting on the work surface ([Figure 3](#)).

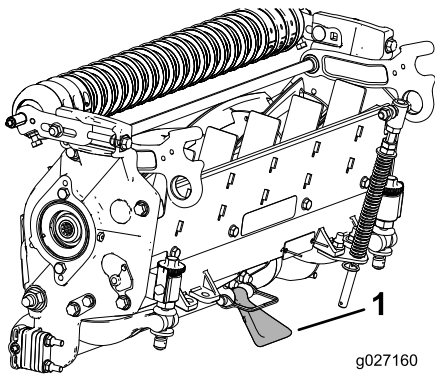

Figure 3

1. Kickstand

4

Installing the Loose Parts

Parts needed for this procedure:

1	Straight grease fitting
1	O-ring

Procedure

The grease fitting must be installed on the reel-motor side of the cutting unit. Refer to Figure 5 to determine the position of the reel motors.

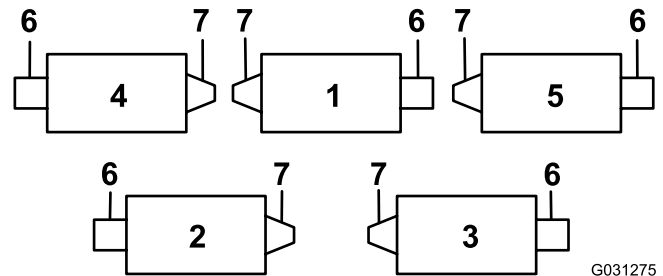

Figure 5

1. Cutting unit 1
2. Cutting unit 2
3. Cutting unit 3
4. Cutting unit 4
5. Cutting unit 5
6. Reel motor
7. Weight

3

Adjusting the Rear Shield

No Parts Required

Procedure

Under most conditions, best dispersion is attained when the rear shield is closed (front discharge). When conditions are heavy or wet, the rear shield may be opened.

To open the rear shield (Figure 4), loosen the cap screw securing the shield to the left side plate, rotate the shield to the open position and tighten the cap screw.

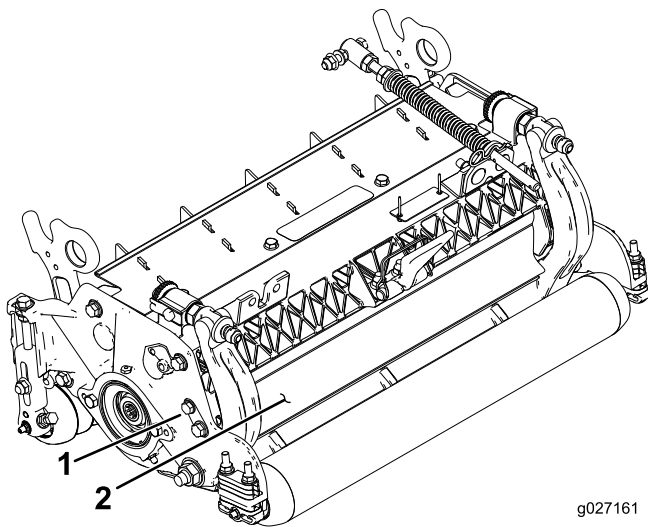

Figure 4

1. Cap screw
2. Rear shield

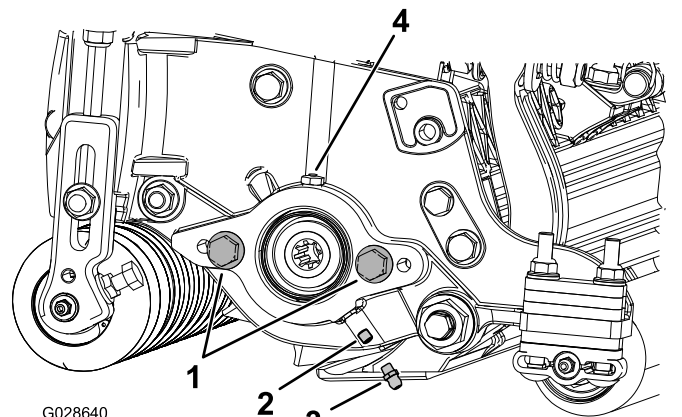
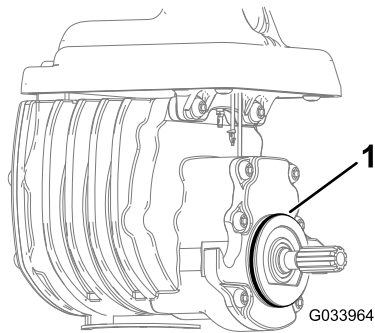

Figure 6

1. Cap screw (2)
2. Setscrew
3. Grease fitting
4. Grease vent

2. Install the straight grease fitting (Figure 6).
3. If there are no cap screws on the reel-motor side plate, install them (Figure 6).
4. Install the O-ring on the reel motor (Figure 7).



g033964

Figure 7

1. O-ring
-

5. Install the reel motor, and grease the side plate until excess grease comes out of the grease vent (Figure 6).

Product Overview

Specifications

Cutting Unit	Weight
03638	54 kg (118 lb)
03639	54 kg (118 lb)
03641	55 kg (121 lb)

Attachments/Accessories

A selection of Toro-approved attachments and accessories is available for use with the machine to enhance and expand its capabilities. Contact your Authorized Service Dealer or Distributor or go to www.Toro.com for a list of all approved attachments and accessories

To best protect your investment and maintain optimal performance of your Toro equipment, count on Toro genuine parts. When it comes to reliability, Toro delivers replacement parts designed to the exact engineering specification of our equipment. For peace of mind, insist on Toro genuine parts.

Operation

Note: Determine the left and right sides of the machine from the normal operating position.

Making Adjustments

Adjusting the Bedknife to the Reel

Use this procedure to set the bedknife to the reel and to check the condition of the reel and bedknife and their interaction. After completing this procedure, always test the cutting unit performance under your field conditions. You may need to make further adjustments to obtain optimal cutting performance.

Important: Do not overtighten the bedknife to the reel or you will damage it.

- After backlapping the cutting unit or grinding the reel, you may need to mow with the cutting unit for a few minutes and then perform this procedure to adjust the bedknife to the reel as the reel and bedknife adjust to each other.
- You may need additional adjustments if the turf is extremely dense or your cutting height is very low.

You will need the following tools to complete this procedure:

- Shim 0.05 mm (0.002 inch)
 - Cutting performance paper
1. Position the cutting unit on a flat, level work surface.
 2. Turn the bedbar-adjusting screws counterclockwise to ensure that the bedbar does not contact the reel ([Figure 8](#)).

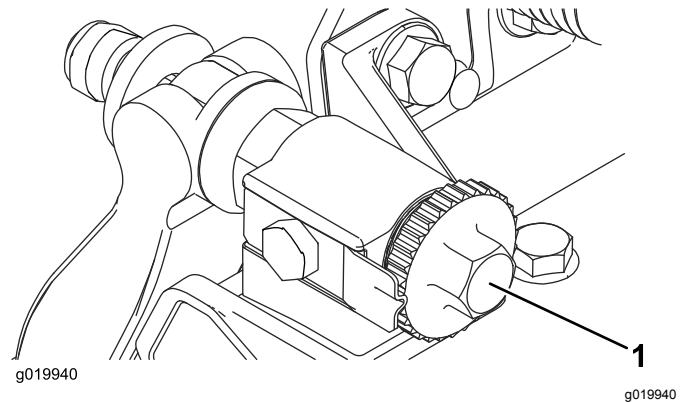

Figure 8

1. Bedbar-adjusting screw

3. Tip the cutting unit to expose the bedknife and reel.

Important: Make sure that the nuts on the back end of the bedbar-adjusting screws are not resting on the work surface ([Figure 9](#)).

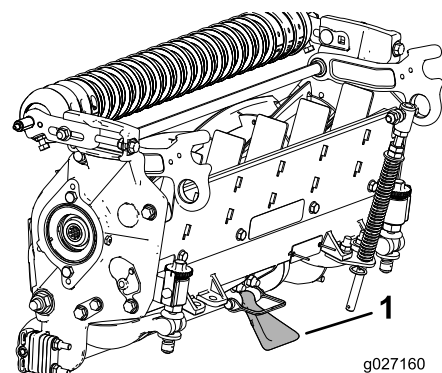

Figure 9

1. Kickstand

- Rotate the reel so that a blade crosses the bedknife approximately 25 mm (1 inch) in from the end of the bedknife on the right side of the cutting unit.

Note: Put an identifying mark on this blade to make subsequent adjustments easier.

- Insert the 0.05 mm (0.002 inch) shim between the marked reel blade and the bedknife at the point where the blade crosses the bedknife.
- Turn the right bedbar adjuster clockwise until you feel **light** pressure (i.e. drag) on the shim, then back off the bedbar adjuster 2 clicks and remove the shim.

Note: Adjusting 1 side of the cutting unit affects the other side, the 2 clicks will provide clearance for when the other side is adjusted.

Note: If starting with a large gap, both sides should initially be drawn closer by alternately tightening the right and left hand sides.

- Slowly** rotate the reel so that the same blade that you checked on the right side is crossing the bedknife approximately 25 mm (1 inch) in from the end of the bedknife on the left side of the cutting unit.
- Turn the left bedbar adjuster clockwise until the shim can be slid through the reel to bedknife gap with light drag.
- Return to the right side and adjust as necessary to get light drag on the shim between the same blade and bedknife.
- Repeat steps 8 and 9 until the shim can be slid through both gaps with slight drag, but one click in on both sides prevents the shim from passing through on both sides.

Note: The bedknife is now parallel to the reel.

Note: This procedure should not be needed on daily adjustments, but should be done after grinding or disassembly.

- From this position (i.e., 1 click in and shim not passing through) turn the bedbar adjusters clockwise 1 click each.

Note: Each click turned moves the bedknife 0.022 mm (0.0009 inch). **Do not overtighten the adjusting screws.**

- Test the cutting performance by inserting a long strip of Toro cutting performance paper between reel and bedknife, perpendicular to the bedknife (Figure 10).

Note: **Slowly** rotate the reel forward; it should cut the paper.

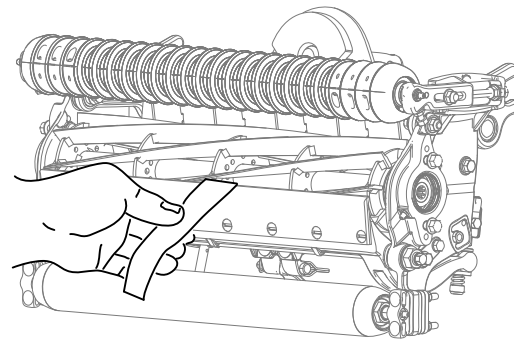

g027166

g027166

Figure 10

Note: If excessive reel drag occurs either backlap or grind the cutting unit to achieve the sharp edges needed for precision cutting.

Adjusting the Rear Roller

- Adjust the rear roller brackets (Figure 11) to the desired height-of-cut range by positioning the required amount of spacers below the side-plate mounting flange (Figure 11) per the HOC Chart.

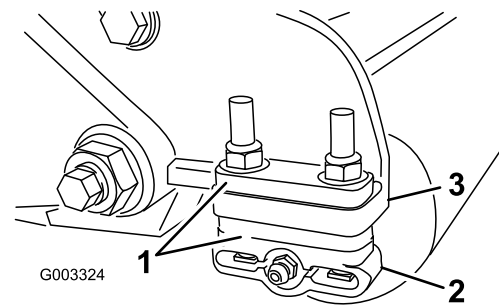

G003324

g003324

Figure 11

- Spacer
- Roller bracket
- Side-plate mounting flange

- Raise the rear of the cutting unit and place a block under the bedknife.
- Remove the 2 nuts securing each roller bracket and the spacer to each side-plate mounting flange.
- Lower the roller and the screws from the side-plate mounting flanges and spacers.
- Place the spacers onto the screws on the roller brackets.
- Re-secure the roller bracket and the spacers to underside of the side-plate mounting flanges with the nuts previously removed.
- Verify that the bedknife-to-reel contact is correct. Tip the mower to expose the front and rear rollers and the bedknife.

Note: The position of the rear roller to the reel is controlled by the machining tolerances of the

assembled components, and so paralleling is not required. A limited amount of adjustment is possible by setting the cutting unit on a surface plate and loosening the side-plate mounting cap screws (Figure 12).

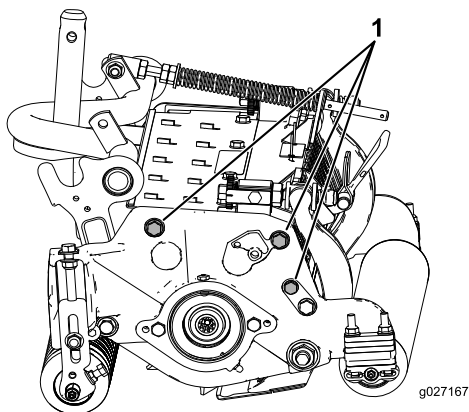

Figure 12

1. Side-plate mounting cap screws

8. Adjust and tighten the cap screws and torque the cap screws to 37 to 45 N·m (27 to 33 ft-lb).

Height-of-Cut Chart Terms

Height-of-Cut Setting (HOC)

This corresponds to the desired height of cut.

Bench Set Height-of-Cut

The bench set height of cut is the height at which the top edge of the bedknife is set above a flat level surface that contacts the bottom of both the front roller and rear roller.

Effective Height of Cut

This is the actual height that the grass has been cut. For a given bench set height-of-cut, the actual height-of-cut will vary depending on the type of grass, time of year, turf, and soil conditions. The cutting unit setup (aggressiveness of cut, rollers, bedknives, attachments installed, turf compensation settings, etc.) will also affect the effective height of cut. Check the effective height of cut using the Turf Evaluator (Model 04399) regularly to determine the desired bench set height of cut.

Aggressiveness of Cut

The aggressiveness of cut has a significant impact on the performance of the cutting unit. Aggressiveness

of cut refers to the angle of the bedknife relative to the ground (Figure 13).

The best cutting unit setup is dependent on your turf conditions and desired results. Experience with the cutting unit on your turf will determine the best setting to use. Aggressiveness of cut may be adjusted throughout the cutting season to allow for various turf conditions.

In general, less to normal aggressive settings are more appropriate for warm-season grasses (Bermuda, paspalum, zoysia) while cool-season grasses (bent, bluegrass, rye) may require normal to more aggressive setups. More aggressive setups cut more grass off by allowing the spinning reel to pull more grass up into the bedknife.

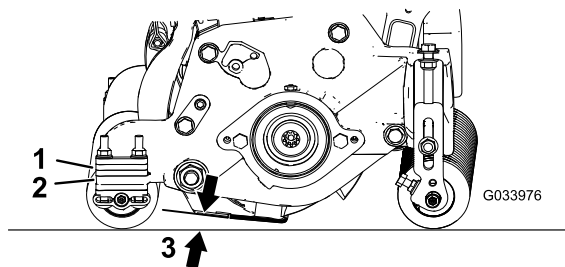

Figure 13

1. Rear spacers
2. Side-plate mounting flange
3. Aggressiveness of cut

Rear Spacers

The number of rear spacers determines the aggressiveness of cut for the cutting unit. For a given height of cut, adding spacers below the side-plate mounting flange increases the aggressiveness of the cutting unit. All cutting units on a given machine must be set to the same aggressiveness of cut (number of rear spacers, Toro Part No. 106-3925); otherwise, the after-cut appearance could be negatively affected (Figure 13).

Chain Links

The location at which the lift-arm chain is attached determines the pitch angle of the rear roller (Figure 14).

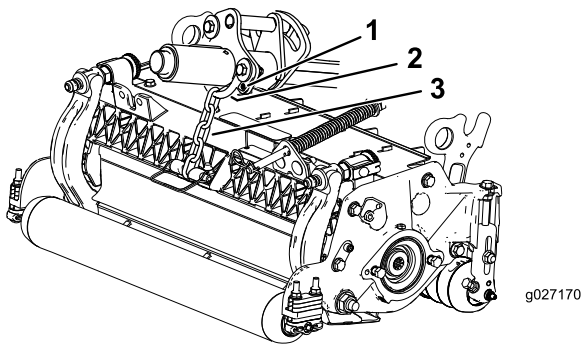

Figure 14

- 1. Lift chain
- 2. U-bucket
- 3. Bottom hole

Groomer

These are the recommended height-of-cut settings when a groomer kit is installed on the cutting unit.

Height-of-Cut Chart

These are the recommended height-of-cut settings when a groomer kit is installed on the cutting unit.

HOC Setting	Aggressiveness of Cut	No. of Rear Spacers	No. of Chain Links	With Groomer kits installed**
0.64 cm (0.250 inch)	Less	0	5	Y
	Normal	0	5	Y
	More	1	5	-
0.95 cm (0.375 inch)	Less	0	5	Y
	Normal	1	5	Y
	More	2	5	-
1.27 cm (0.500 inch)	Less	0	5	Y
	Normal	1	5	Y
	More	2	5	Y
1.56 cm (0.625 inch)	Less	1	5	Y
	Normal	2	5	Y
	More	3	5	-
1.91 cm (0.750 inch)	Less	2	5	Y
	Normal	3	5	Y
	More	4	5	-
2.22 cm (0.875 inch)	Less	2	5	Y
	Normal	3	5	Y
	More	4	5	-
2.54 cm (1.000 inch)	Less	3	5	Y
	Normal	4	5	Y
	More	5	4+	-
2.86 cm (1.125 inches)	Less	4	5	-
	Normal	5	5	-
	More	6	5	-
3.18 cm (1.250 inches)* +	Less	4	5	-
	Normal	5	5	-
	More	6	5	-
3.49 cm (1.375 inches)*+	Less	4	5	-
	Normal	5	5	-
	More	6	5	-
3.81 cm (1.500 inches)*+	Less	5	5	-
	Normal	6	5	-
	More	7	5	-
4.13 cm (1.625 inches)*+	Less	6	4	-
	Normal	7	4	-
	More	8	4	-
4.44 cm (1.750 inches)*+	Less	6	4	-
	Normal	7	4	-
	More	8	5	-
4.76 cm (1.875 inches)*+	Less	7	4	-
	Normal	8	5	-
	More	9	5	-
5.08 cm (2.000 inches)*+	Less	7	5	-
	Normal	8	5	-
	More	9	5	-

+ Indicates that the U-bracket, on the lift arm, is positioned in the bottom hole (Figure 14).

* The High HOC Kit (Part No. 137-0890) must be installed. Position the HOC bracket in the top side-plate hole.

** Y indicates that this combination of HOC and spacers can be used with groomers.

Note: Changing 1 chain link changes the pitch-angle movement of the rear roller by 4.5 degrees.

Note: Changing the U-bracket on the lift arm to the bottom hole adds 2.3 degrees to the pitch angle of the rear roller.

Adjusting the Height of Cut (HOC)

Note: For heights of cut greater than 2.54 cm (1.00 inch) the High Height-of-Cut Kit must be installed.

1. Loosen the locknuts securing the height-of-cut arms to the cutting-unit side plates (Figure 15).

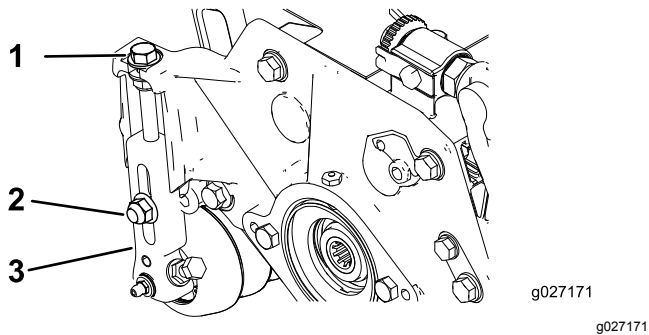

Figure 15

1. Adjusting screw
2. Locknut
3. Height-of-cut arm

2. Loosen the nut on the gauge bar (Figure 16) and set the adjusting screw to the desired height of cut.

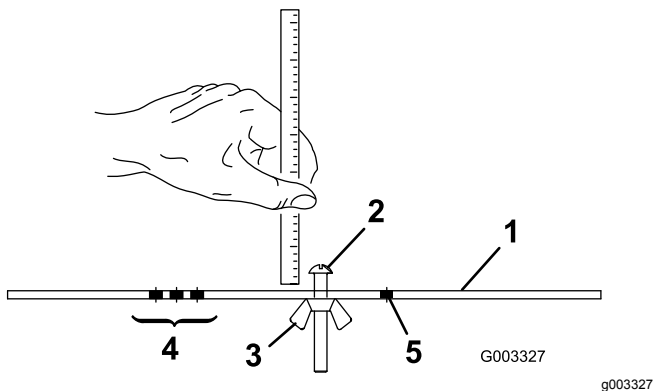

Figure 16

1. Gauge bar
2. Height adjusting screw
3. Nut
4. Holes used for setting groomer HOC
5. Hole not used

3. Measure the distance between the bottom of the screw head and the face of the bar to get the height of cut.
4. Hook the screw head on the cutting edge of the bedknife and rest the rear end of the bar on the rear roller (Figure 17).

Note: For checking the HOC on cutting units installed with shoulder rollers, place the gauge bar on the larger diameter shoulders on the ends of the shoulder roller.

5. Rotate the adjusting screw until the front roller contacts the gauge bar (Figure 17).

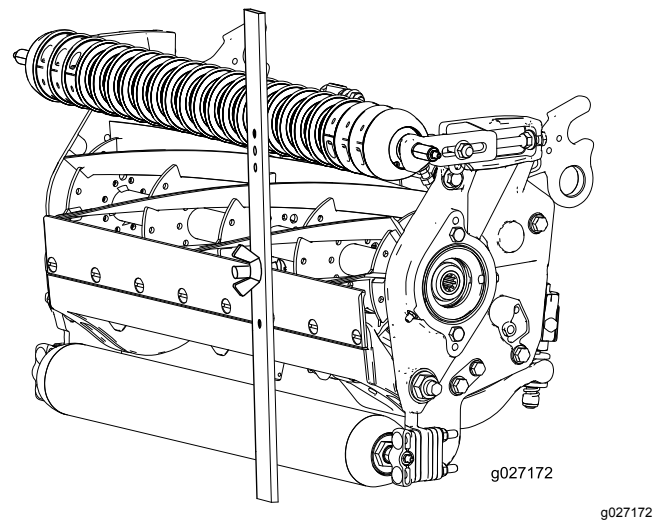

Figure 17

6. Adjust both ends of the roller until the entire roller is parallel to the bedknife.

Important: When set properly, the rear and front rollers will contact the gauge bar and the screw will be snug against the bedknife. This ensures that the height of cut is identical at both ends of the bedknife.

7. Tighten the nuts to secure the adjustment.

Note: Do not overtighten the nuts. Tighten them just enough to remove play from the washer.

Use the following chart to determine which bedknife is best suited for the desired height of cut.

Bedknife/Height of Cut Chart			
Bedknife	Part No.	Bedknife Lip Height	Height of Cut
Low HOC (Optional)	110-4084	5.6 mm (0.220 inch)	6.4 to 12.7 mm (0.250 to 0.500 inch)
EdgeMax® Low HOC (Model 03641)	137-0832	5.6 mm (0.220 inch)	6.4 to 12.7 mm (0.250 to 0.500 inch)
Extended Low HOC (Optional)	120-1640	5.6 mm (0.220 inch)	6.4 to 12.7 mm (0.250 to 0.500 inch)
Extended EdgeMax® Low HOC (Optional)	119-4280	5.6 mm (0.220 inch)	6.4 to 12.7 mm (0.250 to 0.500 inch)
EdgeMax® (Models 03638 and 03639)	137-0833	6.9 mm (0.270 inch)	9.5 to 38.1 mm (0.375 to 1.50 inches)*
Standard (Optional)	108-9096	6.9 mm (0.270 inch)	9.5 to 38.1 mm (0.375 to 1.50 inches)*
Heavy Duty (Optional)	110-4074	9.3 mm (0.370 inch)	12.7 to 38.1 mm (0.500 to 1.50 inches)

* Warm-season grasses may require the Low HOC bedknife for 12.7 mm (0.500 inch) and below.

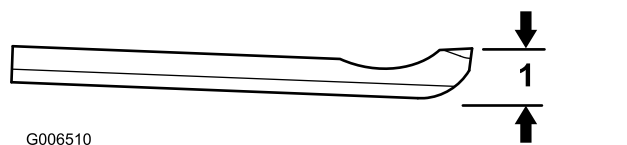

Figure 18

1. Bedknife lip height

Adjusting the Turf-Compensation Settings

The turf-compensation spring transfers the weight from the front to the rear roller. This helps to reduce a wave pattern in the turf, also known as marcelling or bobbing.

Important: Make the spring adjustments with the cutting unit mounted to the traction unit, pointing straight ahead and lowered to the shop floor.

1. Make sure that the hairpin cotter is installed in the rear hole in the spring rod (Figure 19).

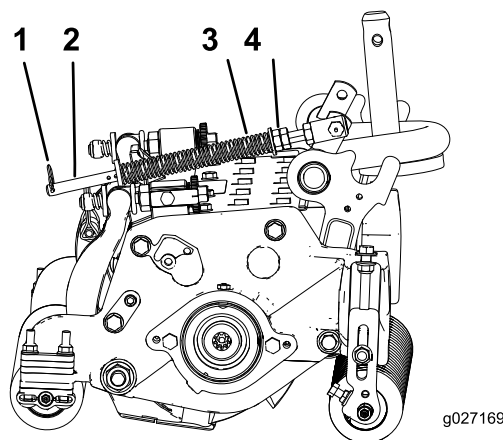

Figure 19

1. Turf-compensation spring
2. Hairpin cotter
3. Spring rod
4. Hex nuts

2. Tighten the hex nuts on the front end of the spring rod until the compressed length of the spring is 15.9 cm (6.25 inches) (Figure 19).

Note: When operating the machine on rough terrain, decrease the spring length by 12.7 mm (1/2 inch).

Note: The turf-compensation setting will need to be reset if the HOC setting or the aggressiveness-of-cut setting is changed.

Checking and Adjusting the Cutting Unit

The dual knob bedknife-to-reel adjustment system incorporated in this cutting unit simplifies the adjustment procedure needed to deliver optimum mowing performance. The precise adjustment possible with the dual knob/bedbar design gives the necessary control to provide a continual self-sharpening action—thus maintaining sharp cutting edges, ensuring good quality of cut, and greatly reducing the need for routine backlapping.

Prior to mowing each day, or as required, check each cutting unit to verify proper bedknife-to-reel contact. **This must be performed even though the quality of cut is acceptable.**

1. Slowly rotate the reel in a reverse direction, listening for reel-to-bedknife contact.

Note: The adjustment knobs have detents corresponding to 0.018 mm (0.0007 inch) bedknife movement for each indexed position. Refer to [Adjusting the Bedknife to the Reel](#) (page 8).

2. Test the cutting performance by inserting a long strip of cutting performance paper (Toro Part 125-5610) between reel and bedknife, perpendicular to the bedknife (Figure 20). Slowly rotate the reel forward; it should cut the paper.

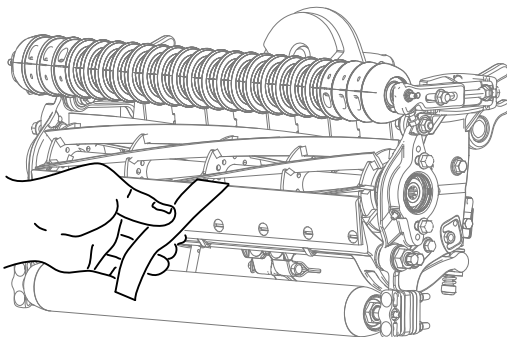

Figure 20

g027166
g027166

Note: If excessive contact/reel drag is evident it will be either necessary to backlap, reface the front of the bedknife, or grind the cutting unit to achieve the sharp edges needed for precision cutting (refer to the Toro Manual for Sharpening Reel and Rotary Mowers, Form No. 09168SL).

Important: Light contact is preferred at all times. If you do not maintain light contact, the bedknife and reel edges will not sufficiently self-sharpen and will dull after a period of operation. If you maintain excessive contact, the bedknife and reel will wear quicker, wear unevenly, and the quality of cut may be adversely affected.

Note: After extended running, a ridge will eventually develop at both ends of the bedknife. Round off or file these notches flush with the cutting edge of the bedknife to ensure smooth operation.

Note: Over time, you will need to grind the chamfer (Figure 21), as it is only designed to last 40% of the bedknife life.

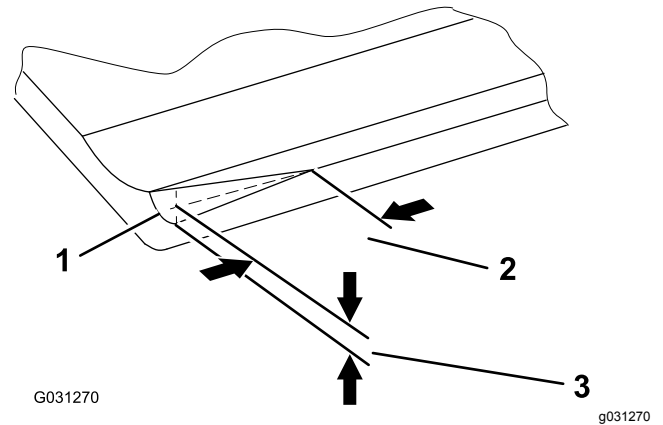

Figure 21

1. Lead-in chamfer on right end of bedknife
2. 6 mm (0.25 inch)
3. 1.5 mm (0.060 inch)

Note: Do not make the lead-in chamfer too large as it may cause turf tufting.

Maintenance

Lubricating the Cutting Units

Each cutting unit has 5 grease fittings (Figure 22) that must be lubricated regularly with No. 2 lithium grease.

There are 2 lubrication points on the front roller, rear roller, and 1 at the reel motor spline.

Note: Lubricating cutting units immediately after washing helps purge water out of the bearings and increases bearing life.

1. Wipe each grease fitting with a clean rag.
2. Apply grease until clean grease comes out of the roller seals and the bearing relief valve.
3. Wipe any excess grease away.

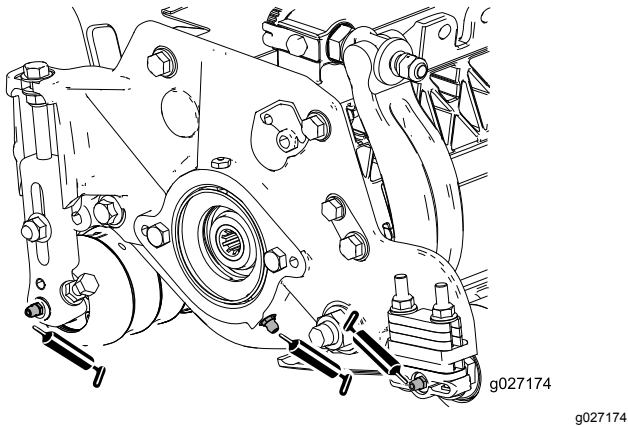

Figure 22

Grease fitting locations on the reel motor side.

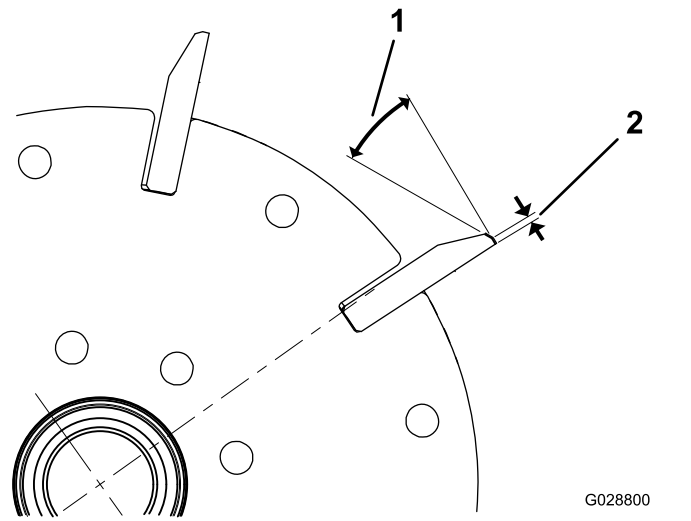

Figure 23
Model 03638

1. 30 degrees

2. 1.3 mm (0.050 inch)

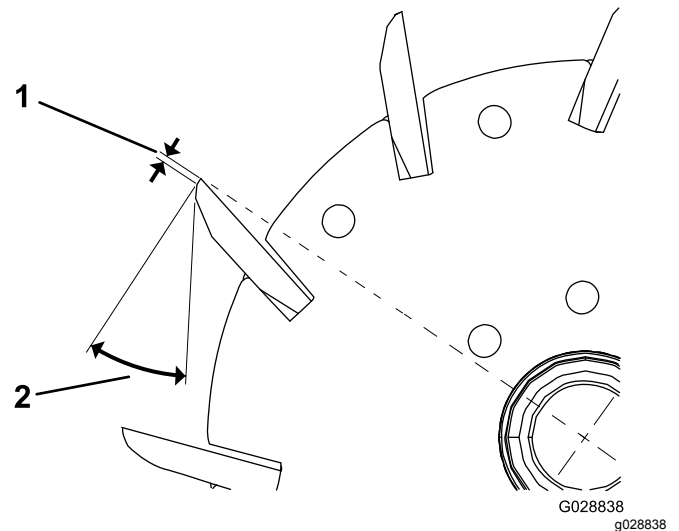

Figure 24

Models 03639 and 03641

1. 1.3 mm (0.050 inch)

2. 30 degrees

2. Spin grind the reel to achieve <math><0.025\text{ mm (0.001 inch)}</math> reel run-out.

Note: This causes the land width to grow slightly.

Note: To extend the longevity of the sharpness of the edge of the reel and the bedknife—after grinding the reel and/or the bedknife—check the reel to bedknife contact again after cutting 2 faiways, as any burrs will be removed, which may create improper reel to bedknife clearance and thus accelerate wear.

Relief-Grinding the Reel

The new reel has a land width of 1.3 to 1.5 mm (0.050 to 0.060 inch) and a 30 degree relief grind.

When the land width gets larger than 3 mm (0.120 inch) wide, do the following:

1. Apply a 30 degree relief grind on all reel blades until the land width is 1.3 mm (0.050 inch) wide (Figure 23 and Figure 24).

Servicing the Bedknife

The bedknife service limits are listed in the following chart.

Important: Operating the cutting unit with the bedknife below the service limit may result in poor after-cut appearance and reduce the structural integrity of the bedknife for impacts.

Bedknife Service Limit Chart				
Bedknife	Part	Bedknife Lip Height *	Service Limit *	Grind Angles Top/Front Angles
EdgeMax® Low HOC (Model 03641)	137-0832	5.6 mm (0.220 inch)	6.4-12.7 mm (0.250-0.500 inch)	10/5 Degrees
Low HOC (Optional)	110-4084	5.6 mm (0.220 inch)	4.8 mm (0.190 inch)	10/5 Degrees
Extended EdgeMax® Low HOC (Optional)	119-4280	5.6 mm (0.220 inch)	4.8 mm (0.190 inch)	10/10 Degrees
Extended Low HOC (Optional)	120-1640	5.6 mm (0.220 inch)	4.8 mm (0.190 inch)	10/10 Degrees
EdgeMax® (Models 03638 and 03639)	137-0833	6.9 mm (0.270 inch)	4.8 mm (0.190 inch)	10/5 Degrees
Standard (Optional)	108-9096	6.9 mm (0.270 inch)	4.8 mm (0.190 inch)	10/5 Degrees
Heavy Duty (Optional)	110-4074	9.3 mm (0.370 inch)	4.8 mm (0.190 inch)	10/5 Degrees

Recommended Top and Front Bedknife Grind Angles (Figure 25)

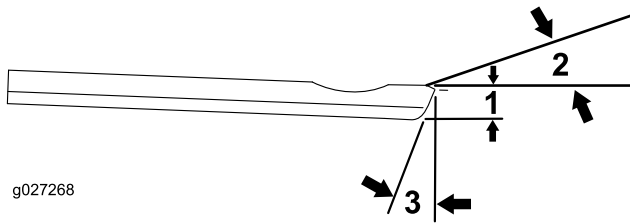

Figure 25

1. Bedknife service limit *
2. Top grind angle
3. Front grind angle

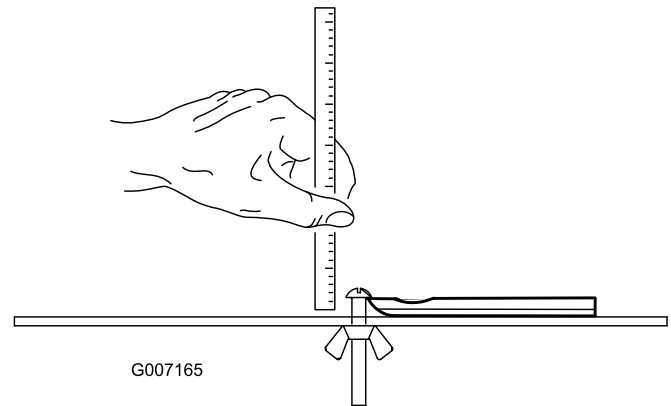

Figure 26

Note: All bedknife service limit measurements reference the bottom of the bedknife (Figure 26)

Checking the Top Grind Angle

The angle that you use to grind your bedknives is very important.

Use the angle indicator (Toro Part No. 131-6828) and the angle-indicator mount (Toro Part No. 131-6829) to check the angle that your grinder produces and then correct for any grinder inaccuracy.

1. Place the angle indicator on the bottom side of the bedknife as shown in Figure 27.

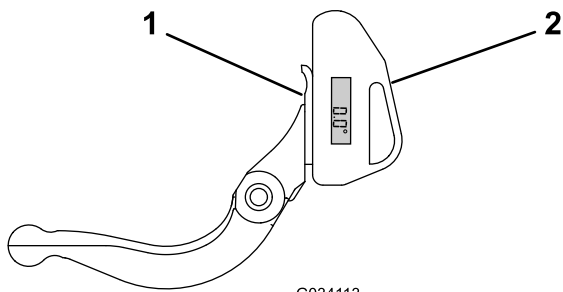

G034113

g034113

Figure 27

1. Bedknife (vertical)
2. Angle indicator

2. Press the Alt Zero button on the angle indicator.
3. Place the angle-indicator mount on the edge of the bedknife so that the edge of the magnet mates with the edge of the bedknife (Figure 28).

Note: The digital display should be visible from the same side during this step as it was in step 1.

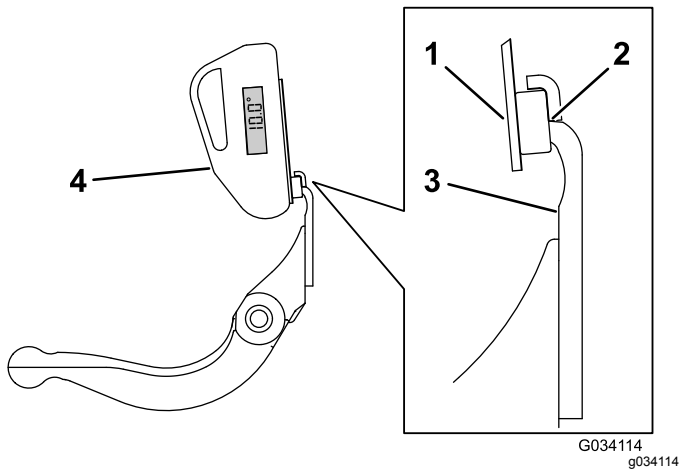

G034114

g034114

Figure 28

1. Angle-indicator mount
2. Edge of the magnet mated with the edge of the bedknife
3. Bedknife
4. Angle indicator

4. Place the angle indicator on the mount as shown in Figure 28.

Note: This is the angle that your grinder produces, and should be within 2 degrees of the recommended top grind angle.

Servicing the Bedbar

Removing the Bedbar

1. Turn the bedbar-adjusting screws counterclockwise to back the bedknife away from the reel (Figure 29).

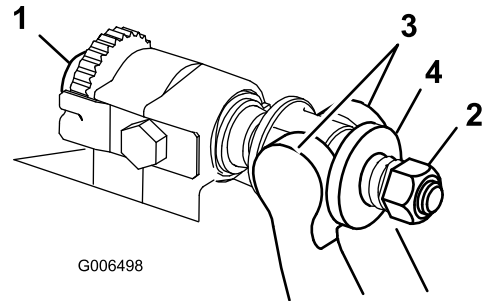

G006498

g006498

Figure 29

1. Bedbar-adjusting screw
2. Spring-tension nut
3. Bedbar
4. Washer

2. Back out the spring-tension nut, until the washer is no longer tensioned against the bedbar (Figure 29).
3. On each side of the machine, loosen the locknut securing the bedbar bolt (Figure 30).

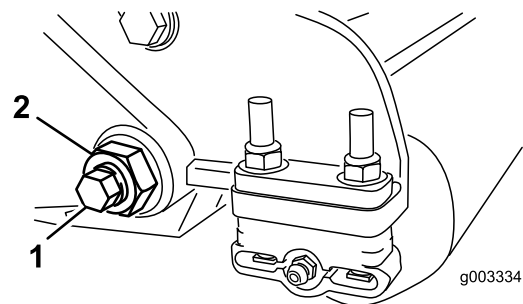

g003334

g003334

Figure 30

1. Bedbar bolt
2. Locknut

4. Remove each bedbar bolt allowing bedbar to be pulled downward and removed from the machine bolt (Figure 30).

Note: Account for 2 nylon and 1 stamped steel washer on each end of the bedbar (Figure 31).

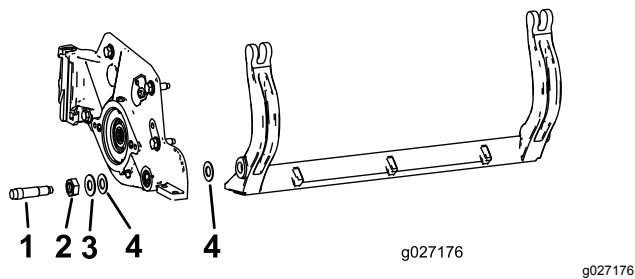

Figure 31

- | | |
|----------------|-----------------|
| 1. Bedbar bolt | 3. Steel washer |
| 2. Nut | 4. Nylon washer |

Assembling the Bedbar

1. Install the bedbar, positioning the mounting ears between the washer and bedbar adjuster.
2. Secure the bedbar to each side plate with the bedbar bolts (nuts on bolts) and the 6 washers.

Note: Position a nylon washer on each side of the side-plate boss. Place a steel washer outside each of the nylon washers ([Figure 31](#)).

3. Torque the bedbar bolts to 37 to 45 N·m (27 to 33 ft-lb).

Note: Tighten the locknuts until the outside steel washer stops rotating and the end play is removed but, do not overtighten or deflect the side plates. Washers on the inside may have a gap.

4. Tighten the spring tension nut until the spring is collapsed, then back off 1/2 turn ([Figure 32](#)).

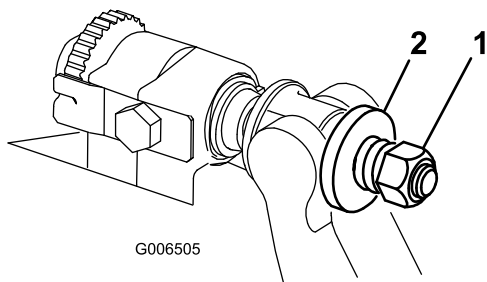

Figure 32

- | | |
|-----------------------|-----------|
| 1. Spring tension nut | 2. Spring |
|-----------------------|-----------|

Servicing the HD Dual Point Adjusters (DPA)

1. Remove all parts (refer to the *Installation Instructions* for the HD DPA Kit and to [Figure 33](#)).
2. Apply anti-seize compound to the inside of the bushing area on cutting unit center frame ([Figure 33](#)).
3. Align the keys on flange bushings to the slots in the frame and install the bushings ([Figure 33](#)).

4. Install a wave washer onto the adjuster shaft and slide the adjuster shaft into the flange bushings in the frame of the cutting unit ([Figure 33](#)).
5. Secure the adjuster shaft with a flat washer and locknut ([Figure 33](#)).
6. Torque the lock nut to 20 to 27 N·m (15 to 20 ft-lb).

Note: The bedbar adjuster shaft has left-hand threads.

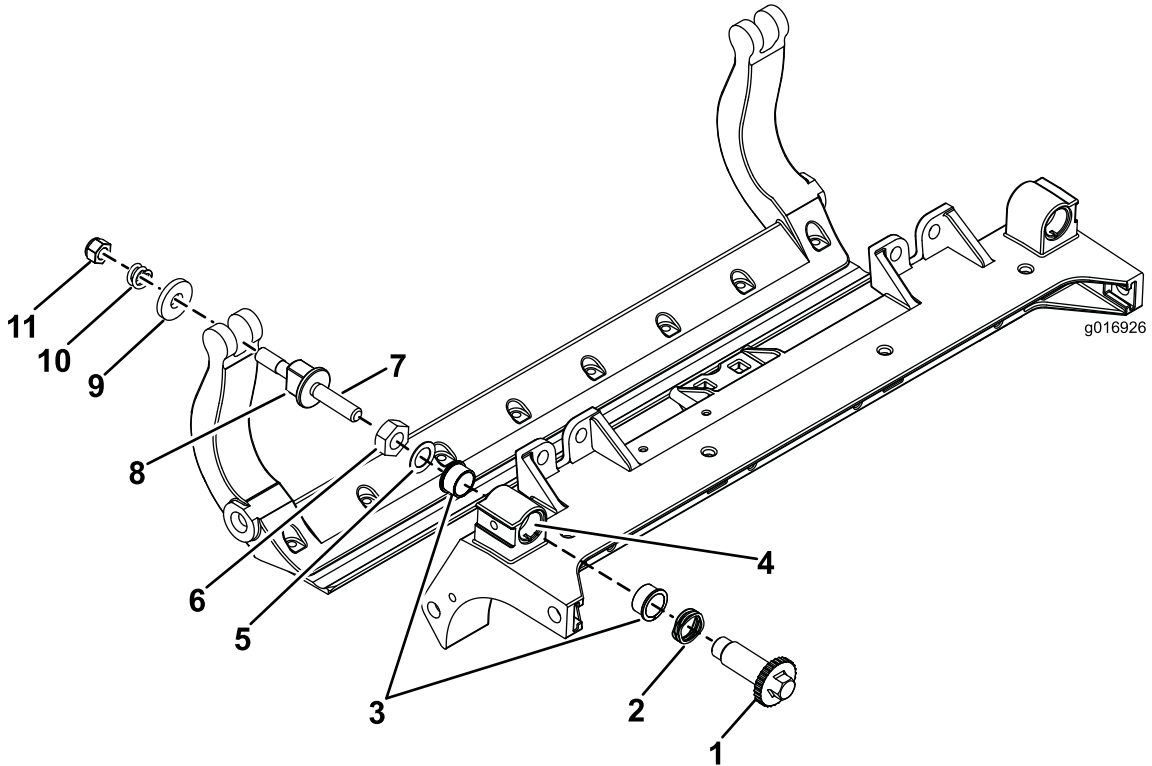

Figure 33

- | | | | |
|-------------------|------------------------------------|------------------------------------|------------------------|
| 1. Shaft adjuster | 4. Apply anti-seize compound here. | 7. Apply anti-seize compound here. | 10. Compression spring |
| 2. Wave washer | 5. Flat washer | 8. Bedbar-adjuster screw | 11. Spring-tension nut |
| 3. Flange bushing | 6. Locknut | 9. Hardened washer | |

7. Apply anti-seize compound to the threads of the bedbar-adjuster screw that fit into the adjuster shaft.
8. Thread the bedbar-adjuster screw into the adjuster shaft.
9. Loosely install the hardened washer, spring, and spring tension nut onto the adjuster screw.
10. Install the bedbar, positioning the mounting ears between the washer and the bedbar adjuster.
11. Secure the bedbar to each side plate with the bedbar bolts (nuts on bolts) and 6 washers.

Note: Position a nylon washer on each side of the side-plate boss.

12. Place a steel washer outside each of the nylon washers ([Figure 33](#)).
13. Torque the bedbar bolts to 37 to 45 N·m (27 to 33 ft-lb).
14. Tighten the locknuts until the outside steel washer stops rotating and end play is removed but do not overtighten or deflect the side plates.

Note: Washers on the inside may have a gap ([Figure 33](#)).

15. Tighten the nut on each bedbar-adjuster assembly until the compression spring is fully compressed, then loosen the nut 1/2 turn ([Figure 33](#)).

16. Repeat this procedure on the other end of the cutting unit.
17. Adjust the bedknife to the reel; refer to [Adjusting the Bedknife to the Reel \(page 8\)](#).

Servicing the Roller

The roller Rebuild Kit and the Roller Rebuild Tool Kit (Figure 34) are available for servicing the roller. The Roller Rebuild Kit includes all the bearings, bearing

nuts, inner seals and outer seals to rebuild a roller. The Roller Rebuild Tool Kit includes all the tools and the installation instructions required to rebuild a roller with the roller rebuild kit. Refer to your *Parts Catalog* or contact your Authorized Distributor for assistance.

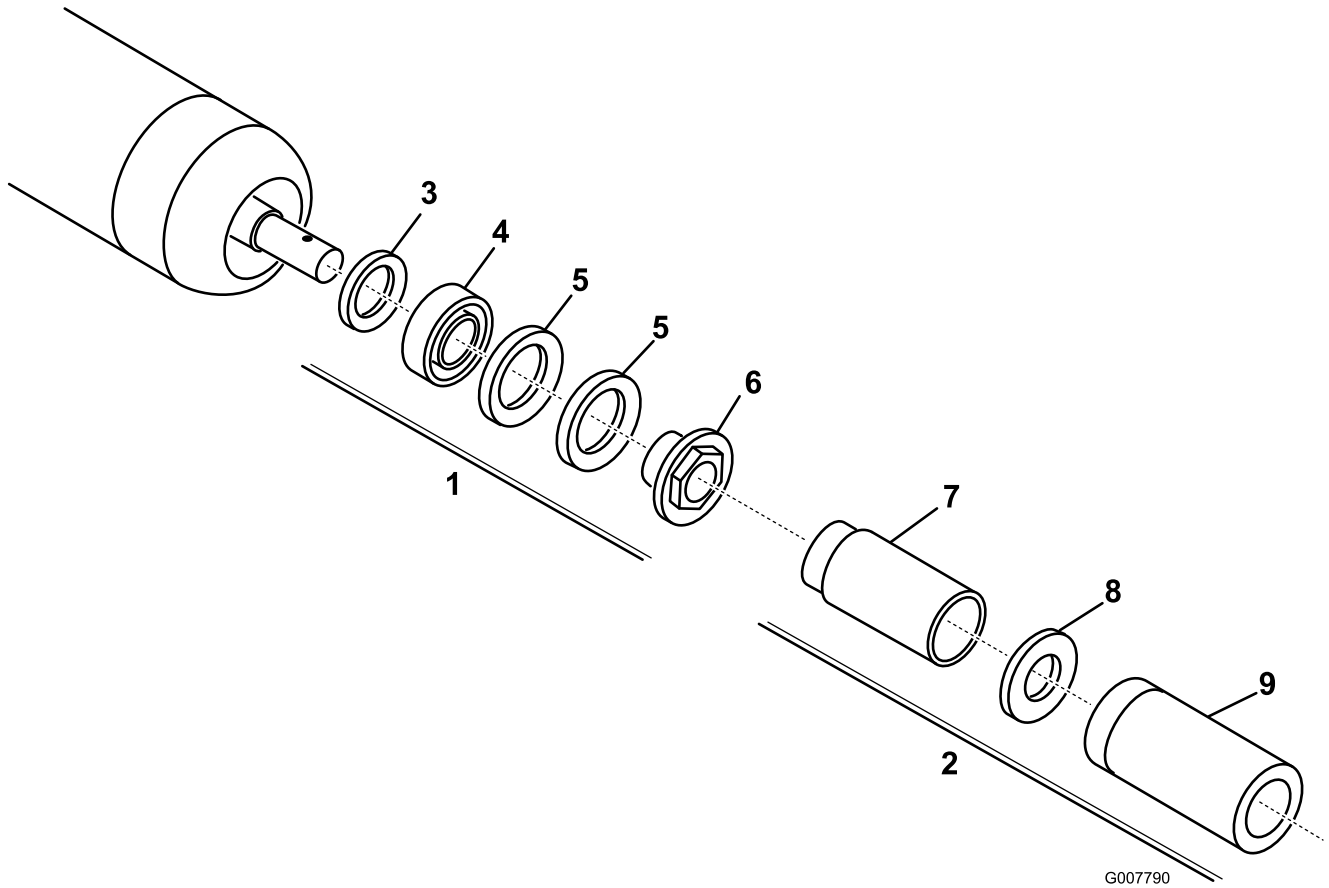

Figure 34

- | | |
|--|----------------------------|
| 1. Roller Rebuild Kit (Part No. 114-5430) | 6. Bearing nut |
| 2. Roller Rebuild Tool Kit (Part No. 115-0803) | 7. Inner-seal tool |
| 3. Inner seal | 8. Washer |
| 4. Bearing | 9. Bearing/outer-seal tool |
| 5. Outer seal | |

Notes:

Notes:

Notes:

Declaration of Incorporation

The Toro Company, 8111 Lyndale Ave. South, Bloomington, MN, USA declares that the following unit(s) conform(s) to the directives listed, when installed in accordance with the accompanying instructions onto certain Toro models as indicated on the relevant Declarations of Conformity.

Model No.	Serial No.	Product Description	Invoice Description	General Description	Directive
03638	400000000 and Up	8-Blade Radial Reel DPA Cutting Unit with 7in Reel	7-INCH, 8-BLADE RR DPA CUTTING UNIT	Cutting Unit	2006/42/EC
03639	400000000 and Up	8-Blade Forward Swept Reel DPA Cutting Unit with 7in Reel	7-INCH, 8-BLADE FSR DPA CUTTING UNIT	Cutting Unit	2006/42/EC
03641	400000000 and Up	11-Blade Forward Swept Reel DPA Cutting Unit with 7in Reel	7-INCH, 11-BLADE FSR DPA CUTTING UNIT	Cutting Unit	2006/42/EC

Relevant technical documentation has been compiled as required per Part B of Annex VII of 2006/42/EC.

We will undertake to transmit, in response to requests by national authorities, relevant information on this partly completed machinery. The method of transmission shall be electronic transmittal.

This machinery shall not be put into service until incorporated into approved Toro models as indicated on the associated Declaration of Conformity and in accordance with all instructions, whereby it can be declared in conformity with all relevant Directives.

Certified:



John Heckel
Sr. Engineering Manager
8111 Lyndale Ave. South
Bloomington, MN 55420, USA
December 11, 2017

Authorized Representative:

Marcel Dutrieux
Manager European Product Integrity
Toro Europe NV
Nijverheidsstraat 5
2260 Oevel
Belgium

Tel. +32 16 386 659

European Privacy Notice

The Information Toro Collects

Toro Warranty Company (Toro) respects your privacy. In order to process your warranty claim and contact you in the event of a product recall, we ask you to share certain personal information with us, either directly or through your local Toro company or dealer.

The Toro warranty system is hosted on servers located within the United States where privacy law may not provide the same protection as applies in your country.

BY SHARING YOUR PERSONAL INFORMATION WITH US, YOU ARE CONSENTING TO THE PROCESSING OF YOUR PERSONAL INFORMATION AS DESCRIBED IN THIS PRIVACY NOTICE.

The Way Toro Uses Information

Toro may use your personal information to process warranty claims, to contact you in the event of a product recall and for any other purpose which we tell you about. Toro may share your information with Toro's affiliates, dealers or other business partners in connection with any of these activities. We will not sell your personal information to any other company. We reserve the right to disclose personal information in order to comply with applicable laws and with requests by the appropriate authorities, to operate our systems properly or for our own protection or that of other users.

Retention of your Personal Information

We will keep your personal information as long as we need it for the purposes for which it was originally collected or for other legitimate purposes (such as regulatory compliance), or as required by applicable law.

Toro's Commitment to Security of Your Personal Information

We take reasonable precautions in order to protect the security of your personal information. We also take steps to maintain the accuracy and current status of personal information.

Access and Correction of your Personal Information

If you would like to review or correct your personal information, please contact us by email at legal@toro.com.

Australian Consumer Law

Australian customers will find details relating to the Australian Consumer Law either inside the box or at your local Toro Dealer.



The Toro Warranty

A Two-Year Limited Warranty

Conditions and Products Covered

The Toro Company and its affiliate, Toro Warranty Company, pursuant to an agreement between them, jointly warrant your Toro Commercial product ("Product") to be free from defects in materials or workmanship for two years or 1500 operational hours*, whichever occurs first. This warranty is applicable to all products with the exception of Aerators (refer to separate warranty statements for these products). Where a warrantable condition exists, we will repair the Product at no cost to you including diagnostics, labor, parts, and transportation. This warranty begins on the date the Product is delivered to the original retail purchaser.

* Product equipped with an hour meter.

Instructions for Obtaining Warranty Service

You are responsible for notifying the Commercial Products Distributor or Authorized Commercial Products Dealer from whom you purchased the Product as soon as you believe a warrantable condition exists. If you need help locating a Commercial Products Distributor or Authorized Dealer, or if you have questions regarding your warranty rights or responsibilities, you may contact us at:

Toro Commercial Products Service Department
Toro Warranty Company
8111 Lyndale Avenue South
Bloomington, MN 55420-1196
952-888-8801 or 800-952-2740
E-mail: commercial.warranty@toro.com

Owner Responsibilities

As the Product owner, you are responsible for required maintenance and adjustments stated in your *Operator's Manual*. Failure to perform required maintenance and adjustments can be grounds for disallowing a warranty claim.

Items and Conditions Not Covered

Not all product failures or malfunctions that occur during the warranty period are defects in materials or workmanship. This warranty does not cover the following:

- Product failures which result from the use of non-Toro replacement parts, or from installation and use of add-on, or modified non-Toro branded accessories and products. A separate warranty may be provided by the manufacturer of these items.
- Product failures which result from failure to perform recommended maintenance and/or adjustments. Failure to properly maintain your Toro product per the Recommended Maintenance listed in the *Operator's Manual* can result in claims for warranty being denied.
- Product failures which result from operating the Product in an abusive, negligent, or reckless manner.
- Parts subject to consumption through use unless found to be defective. Examples of parts which are consumed, or used up, during normal Product operation include, but are not limited to, brake pads and linings, clutch linings, blades, reels, rollers and bearings (sealed or greasable), bed knives, spark plugs, castor wheels and bearings, tires, filters, belts, and certain sprayer components such as diaphragms, nozzles, and check valves, etc.
- Failures caused by outside influence. Conditions considered to be outside influence include, but are not limited to, weather, storage practices, contamination, use of unapproved fuels, coolants, lubricants, additives, fertilizers, water, or chemicals, etc.
- Failure or performance issues due to the use of fuels (e.g. gasoline, diesel, or biodiesel) that do not conform to their respective industry standards.

Countries Other than the United States or Canada

Customers who have purchased Toro products exported from the United States or Canada should contact their Toro Distributor (Dealer) to obtain guarantee policies for your country, province, or state. If for any reason you are dissatisfied with your Distributor's service or have difficulty obtaining guarantee information, contact the Toro importer.

- Normal noise, vibration, wear and tear, and deterioration.
- Normal "wear and tear" includes, but is not limited to, damage to seats due to wear or abrasion, worn painted surfaces, scratched decals or windows, etc.

Parts

Parts scheduled for replacement as required maintenance are warranted for the period of time up to the scheduled replacement time for that part. Parts replaced under this warranty are covered for the duration of the original product warranty and become the property of Toro. Toro will make the final decision whether to repair any existing part or assembly or replace it. Toro may use remanufactured parts for warranty repairs.

Deep Cycle and Lithium-Ion Battery Warranty:

Deep cycle and Lithium-Ion batteries have a specified total number of kilowatt-hours they can deliver during their lifetime. Operating, recharging, and maintenance techniques can extend or reduce total battery life. As the batteries in this product are consumed, the amount of useful work between charging intervals will slowly decrease until the battery is completely worn out. Replacement of worn out batteries, due to normal consumption, is the responsibility of the product owner. Battery replacement may be required during the normal product warranty period at owner's expense. Note: (Lithium-Ion battery only): A Lithium-Ion battery has a part only prorated warranty beginning year 3 through year 5 based on the time in service and kilowatt hours used. Refer to the *Operator's Manual* for additional information.

Maintenance is at Owner's Expense

Engine tune-up, lubrication, cleaning and polishing, replacement of filters, coolant, and completing recommended maintenance are some of the normal services Toro products require that are at the owner's expense.

General Conditions

Repair by an Authorized Toro Distributor or Dealer is your sole remedy under this warranty.

Neither The Toro Company nor Toro Warranty Company is liable for indirect, incidental or consequential damages in connection with the use of the Toro Products covered by this warranty, including any cost or expense of providing substitute equipment or service during reasonable periods of malfunction or non-use pending completion of repairs under this warranty. Except for the Emissions warranty referenced below, if applicable, there is no other express warranty. All implied warranties of merchantability and fitness for use are limited to the duration of this express warranty.

Some states do not allow exclusions of incidental or consequential damages, or limitations on how long an implied warranty lasts, so the above exclusions and limitations may not apply to you. This warranty gives you specific legal rights, and you may also have other rights which vary from state to state.

Note regarding engine warranty:

The Emissions Control System on your Product may be covered by a separate warranty meeting requirements established by the U.S. Environmental Protection Agency (EPA) and/or the California Air Resources Board (CARB). The hour limitations set forth above do not apply to the Emissions Control System Warranty. Refer to the Engine Emission Control Warranty Statement supplied with your product or contained in the engine manufacturer's documentation for details.