



**53cm Recycler[®] /Rear Bagger
Mower**

Model No. 20786 – 8900001 & Up

Parts Catalog

ORDERING REPLACEMENT PARTS

To order replacement parts, please supply: the part number, the quantity, and the description of each part desired.

Contents

Description	Page	Description	Page
Housing Assembly	1	Grass Bag Assembly	6
Engine Assembly	2	Engine GTS-200	7-15
Rear Axle Assembly	3	Toro Part Number Index	16-18
Gear Case Assembly	4	Maintenance	19-21
Handle Assembly	5		

Note:

Accessories

Description	Model / Parts No.	Description	Model / Parts No.
Side Discharge Chute Kit	Model No. 59113		
Dethatcher Kit	Model No. 59131		

Part Description Abbreviations

Part descriptions in this catalog may include the following abbreviations.

Abbreviation	Meaning	Abbreviation	Meaning
AR	as required	HWHTF	hex washer head thread forming
ASM	assembly	INC	incorporated
CARR	carriage	LH	left hand
DEG	degrees	PH	pan head
FH	flat head	PPH	Phillips pan head
GA	gauge	PTO	power take off
HF	hex flange	RH	right hand
HFW	hex flange washer	SFH	slotted fillister head
HH	hex head	SH	square head
HHF	hex head flange	SHWH	slotted hex washer head
HHST	hex head self tapping	SPH	slotted pan head
HJ	hex jam	STD	standard
HOC	height-of-cut	TAP	self tapping
HS	hex socket	TH	truss head
HSBH	hex socket button head	TTH	Torx truss head
HSFH	hex socket flat head	WH	wing head
HSH	hex socket head		
HWH	hex washer head		

Important Format Explanations

This catalog uses special formats to convey information in illustrations and parts lists. Specifically, one format is used in conjunction with service assemblies and another with quantities associated with reference numbers.

Service Assemblies

Parts within service assemblies have reference numbers in the form $X:Y$. X is the reference number of the service assembly and Y is a sequential number unique to each part within the service assembly.

For example, a wheel assembly might be identified by reference number 6, the tire by 6:1, the valve by 6:2, and the wheel by 6:3. When you order the assembly identified by reference number 6, you receive all parts identified by reference numbers 6:1, 6:2, and 6:3. However, you may also order any part individually.

Reference numbers of this type appear in part lists and as callouts in illustrations.

Reference Numbers with Quantities

Illustrations may have a quantity in parentheses next to a reference number, in the form $X (Y)$. X is the reference number. Y in parentheses is the quantity of the part identified by the reference number.

For example, the illustration callout 4 (2) indicates that two parts are used in that instance.

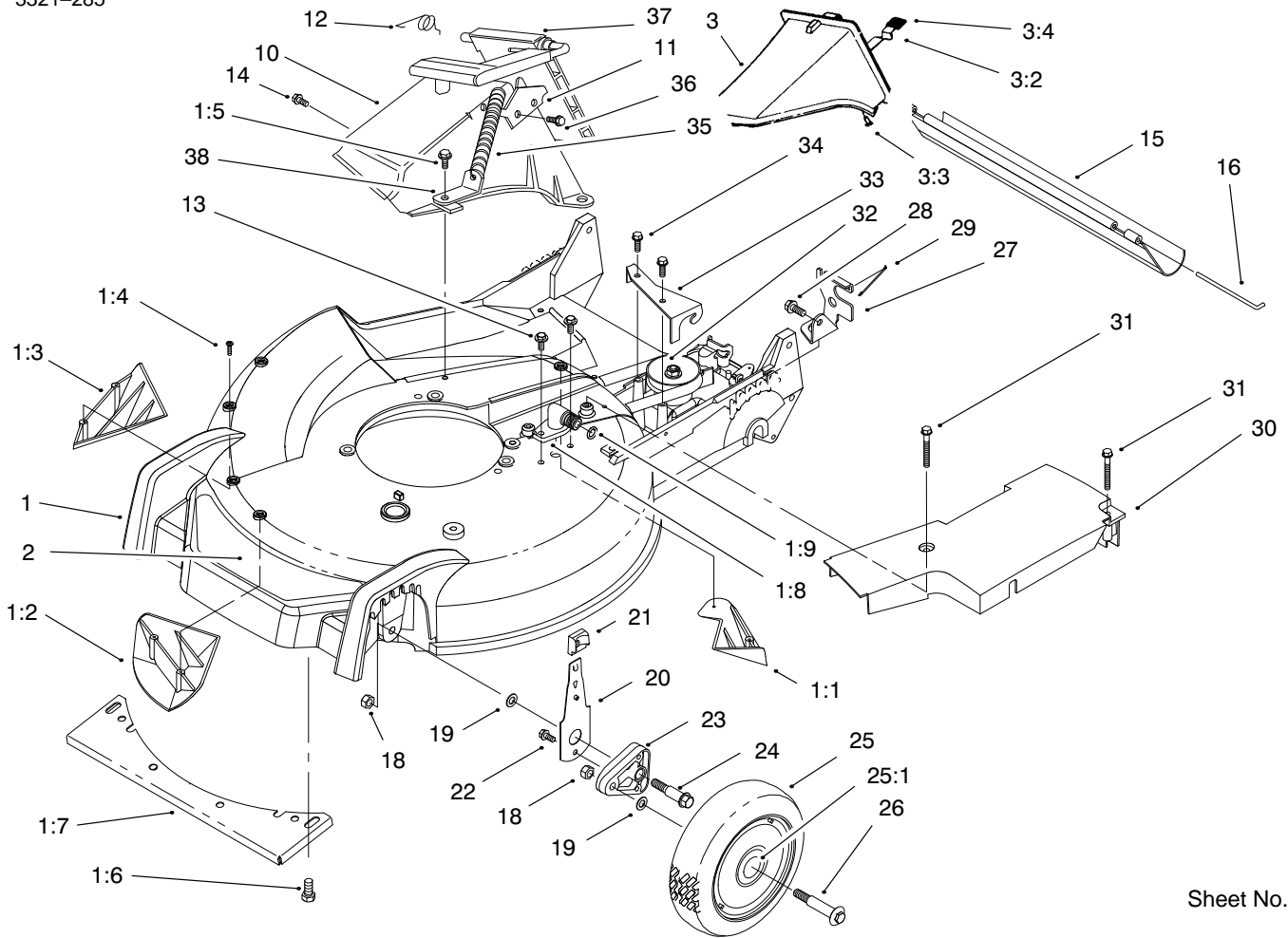

Sheet No.:2

Housing Assembly

Ref. No.	Part No.	Qty.	Description
1	95-5615	1	Housing-Rwd
1:1	92-1750	1	Plate-Kicker Rear
1:2	92-1720	1	Kicker-RH
1:3	92-1730	1	Kicker-LH
1:4	32144-111	6	Screw - PPH
1:5	46-6811	5	Screw-HWH
1:6	32144-70	4	Screw-TAP
1:7	46-5400	1	Shield-front
1:8	95-2747	1	Fitting-Washout
1:9	46-6290	1	O-Ring
2	94-5407	1	Decal-Deck
3	77-0502	1	ASM-Plug
3:2	76-4640	1	Latch Discharge Plug
3:3	3295-35	1	Rivet Solid
3:4	76-4650	1	Grip Latch
10	82-9151	1	Tunnel-Discharge
11	93-3154	1	Plate-Latch
12	80-3770	1	Retainer-Door
14	46-6810	1	Screw HWH
15	44-0580	1	Shield-Trailing
16	33-3208	1	Rod-Shield
18	3296-6	4	Nut-Lock
19	40-1940	4	Washer
20	66-0541	2	ASM-Spring Arm
21	25-7740	2	Knob-Arm
22	32144-85	2	Screw-HH

Ref. No.	Part No.	Qty.	Description
23	66-0580	2	Arm-Pivot
24	66-0560	2	Screw-Shoulder
25	14-9949	2	Wheel & Tire-ASM
25:1	27-6250	4	Bushing
26	27-6232	2	Bolt-Wheel HH
27	82-5680	1	Bracket-Adjustment
28	32144-70	1	Screw-TAP
29	46-7030	1	Retainer-cable
30	98-1502	1	Cover-Belt
31	37-7260	2	Screw-TAP
32	62-6673	1	ASM-Gearcase
33	62-4320	1	Bracket-Guide
34	49-2040	2	Screw-HH
35	76-4660	1	Spring-Extension
36	46-8090	2	Screw-Tapping
37	93-7351	1	ASM-Door
38	71-9350	1	Spring-Bracket

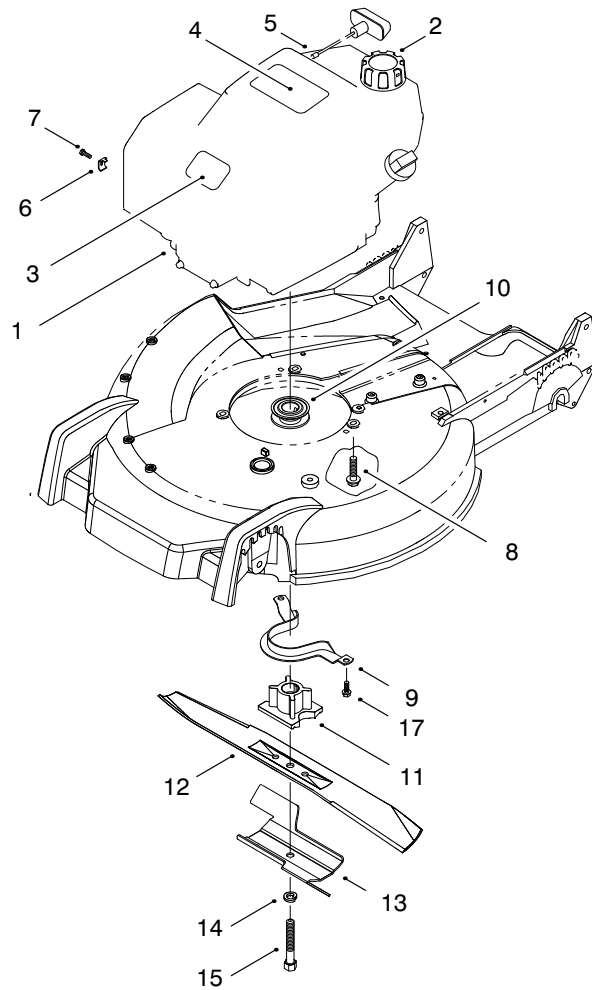

Sheet No.:3

Engine Assembly

Ref. No.	Part No.	Qty.	Description	Ref. No.	Part No.	Qty.	Description
1		1	Engine-Gts Ohv 200				
2	93-7198	1	ASM-Cap				
3	92-2289	1	Plate-Logo				
4	98-2004	1	Decal-Engine				
5	2210-316	1	Rope-Stop				
6	2210-249	1	Clamp-Casing				
7	93-8470	1	Screw-Clamp				
8	32144-102	3	Screw				
9	66-0570	1	Guide-Belt				
10	62-7550	1	Pulley-Driver				
11	93-4107	1	Retainer-Blade				
12	93-4106	1	Blade-Generation Iii				
13	94-1608	1	Stiffener-Blade				
14	3253-22	1	Washer-Lock				
15	26-0670	1	Bolt-Blade				
17	32144-70	2	Screw-TAP				

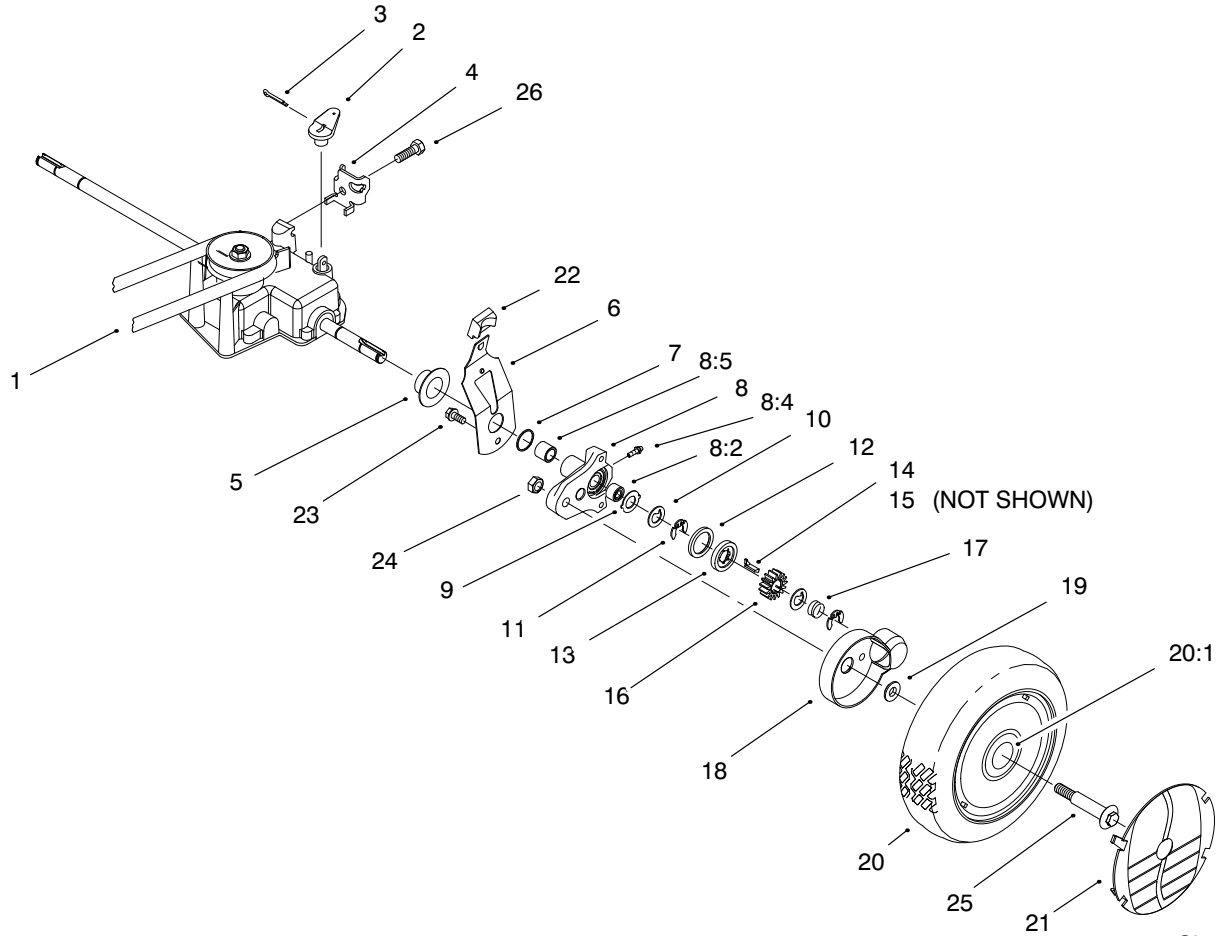

Sheet No.:4

Rear Axle Assembly

Ref. No.	Part No.	Qty.	Description
1	62-3900	1	V-Belt
2	60-8821	1	Lever-Shift
3	3272-10	1	Pin-Cotter
4	82-8780	1	Retainer-Cable
5	42-3520	2	Cap-End
6	63-8721	2	ASM-Arm
7	237-153	2	O-Ring
8	63-8701	2	ASM
8:2	48-2060	2	Bearing-Needle
8:4	302-56	2	Fitting-Grease
8:5	70-9760	2	Bushing
9	65-4730	2	Washer-Thrust
10	65-4740	4	Washer-Thrust
11	65-2720	4	Ring-Retaining
12	65-4710	2	Ring-Friction
13	65-4760	2	Washer
14	66-6050	1	Key-Rocking LH
15	66-6040	1	Key-Locking RH
16	65-4750	2	Gear-Pinion
17	65-4720	2	Spring-Compression
18	74-1660	2	Cover-Wheel
19	74-1671	2	Spacer-Cover
20	14-9959	2	Wheel-ASM
20:1	27-6250	4	Bushing
21	92-7663	1	Cover-Wheel
22	25-7740	2	Knob-Arm

Ref. No.	Part No.	Qty.	Description
23	32144-85	2	Screw-HH
24	3296-6	2	Nut-Lock
25	27-6232	2	Bolt-Wheel HH
26	32144-70	1	Screw-TAP

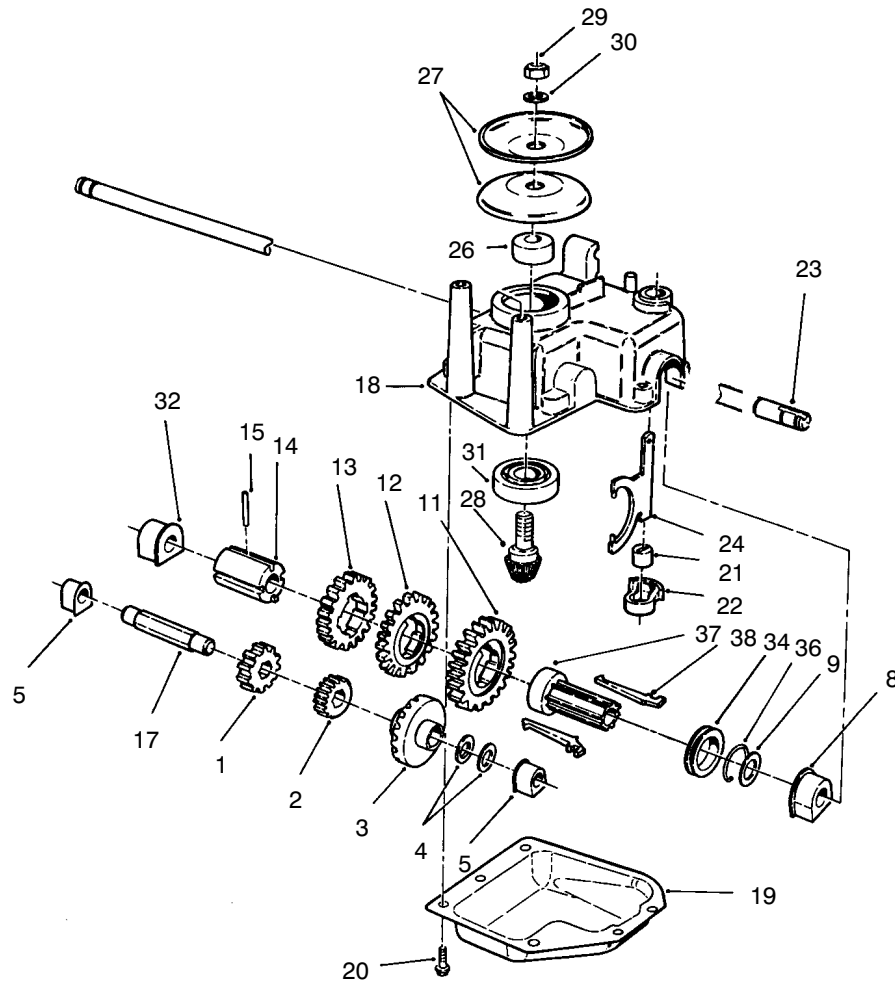

Sheet No.:101

Gear Case Assembly

Ref. No.	Part No.	Qty.	Description	Ref. No.	Part No.	Qty.	Description
1	55-3800	1	Pinion 25t 3rd Gear	32	60-8850	1	Bushing-Output
2	55-3780	1	Pinion 20t 2nd Gear	34	76-0770	1	Collar-Shift
3	55-3760	1	15 T Pinion	36	65-5250	1	Clip-Spring
4	36-4791	2	Washer-Thrust	37	76-0780	1	Sleeve-Shift Key
5	60-8750	2	Bushing	38	76-0760	2	Key-Shift
8	60-8770	1	Bushing-Output Shaft	62-6673		1	Gear Case Complete
9	36-4780	1	Washer-Thrust				
11	55-3770	1	Gear 49t 1st Gear				
12	55-3790	1	Gear 44t 2nd Gear				
13	55-3810	1	Gear 39t 3rd Gear				
14	60-8790	1	Sleeve-Gear				
15	32121-120	1	Pin-Coil				
17	60-8800	1	Shaft-Intermediate				
18	60-8710	1	Gearcase-Upper 3 Sp				
19	60-8730	1	Cover-Gearcase				
20	49-2040	6	Screw-HH				
21	29-9570	1	Bushing-Yoke				
22	60-8810	1	Retainer-Shift-Fork				
23	65-4770	1	Shaft-Output				
24	60-8870	1	Yoke-Shift				
26	62-6660	1	Spacer-Pulley				
27	60-8840	2	Pulley-Half				
28	60-8890	1	Gear-Pinnion				
29	3296-5	1	Nut-Lock				
30	3256-24	1	Washer-Flat				
31	38-7820	1	Bearing-Ball				

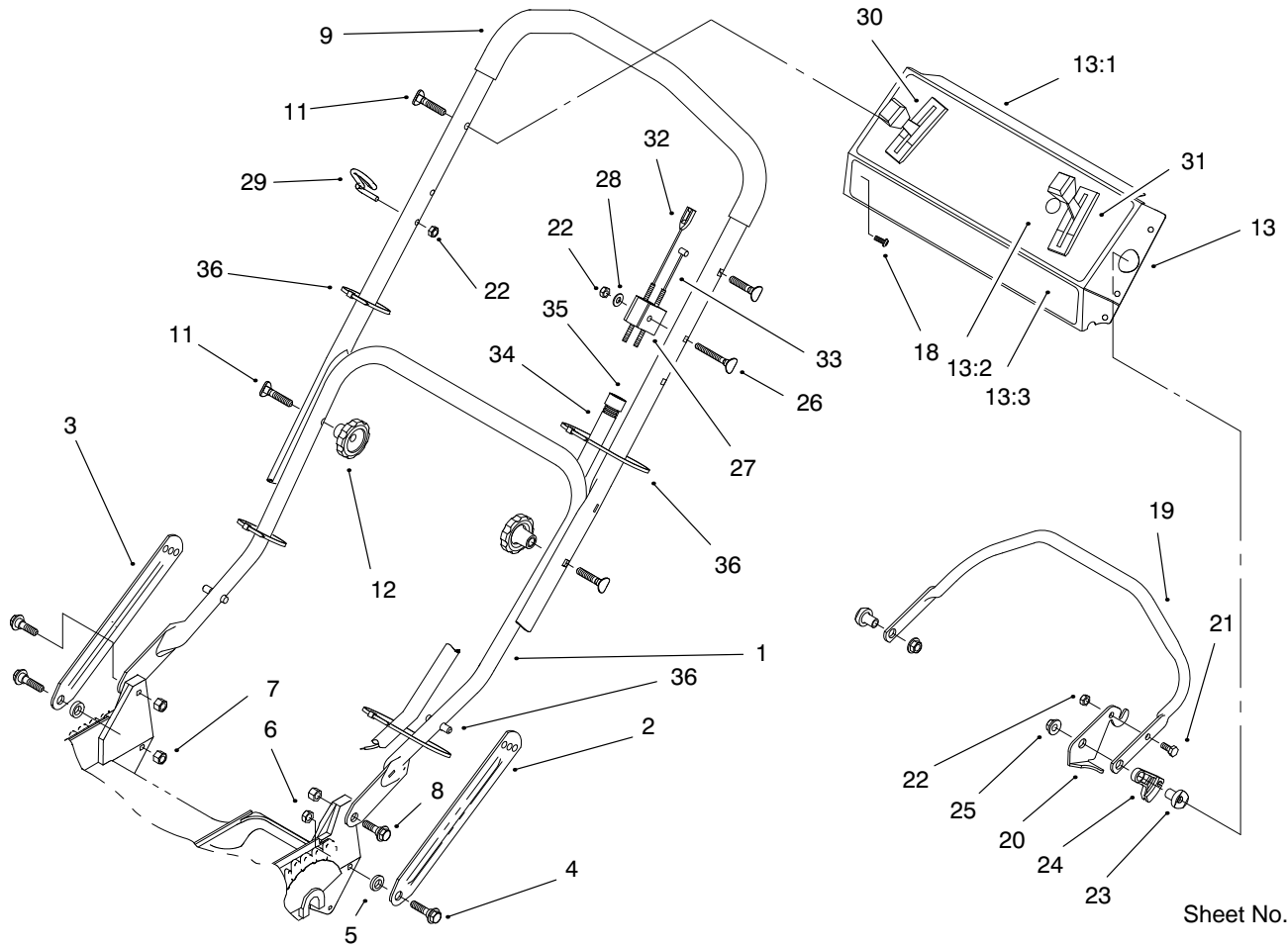

Sheet No.:5

Handle Assembly

Ref. No.	Part No.	Qty.	Description
1	43-1362	1	ASM-Handle
2	84-8361	1	Latch-Handle
3	84-8401	1	Latch-Handle
4	27-7210	2	Screw-Shoulder
5	3-3287	2	Spacer
6	3296-47	1	Nut-Lock
7	3296-72	3	Nut-Lock
8	27-7211	2	Screw-Shoulder
9	94-4922	1	ASM-Handle
11	92-2260	4	Screw-Handle
12	19-4050	2	Knob
13	98-9232	1	Panel-Control
13:1	93-6655	1	Decal-Danger
13:2	98-2020	1	Decal-Instruction
13:3	92-7859	1	Decal-Panel
18	92-9665	5	Screw-Phil
19	52-7430	1	Bar-Control
20	66-5351	1	Lever-Control
21	321-39	1	Screw-HH
22	3296-73	3	Nut-Lock
23	49-1630	2	Spacer-Support
24	46-5520	1	Lever-Traction
25	3296-74	2	Nut-Flange
26	92-2269	1	Screw-Handle
27	46-6980	1	Support-Cable
28	3256-1	1	Washer-Flat

Ref. No.	Part No.	Qty.	Description
29	86-9671	1	Guide-Rope
30	76-2712	1	Control-Speed
31	98-1501	1	Control-Throttle
32	76-4331	1	Cable-Brake
33	46-5481	1	Cable-Traction
34	46-6440	1	Cover-Cables
35	2412-50	3	Clip-Tubing
36	3290-378	4	Tie-Cable

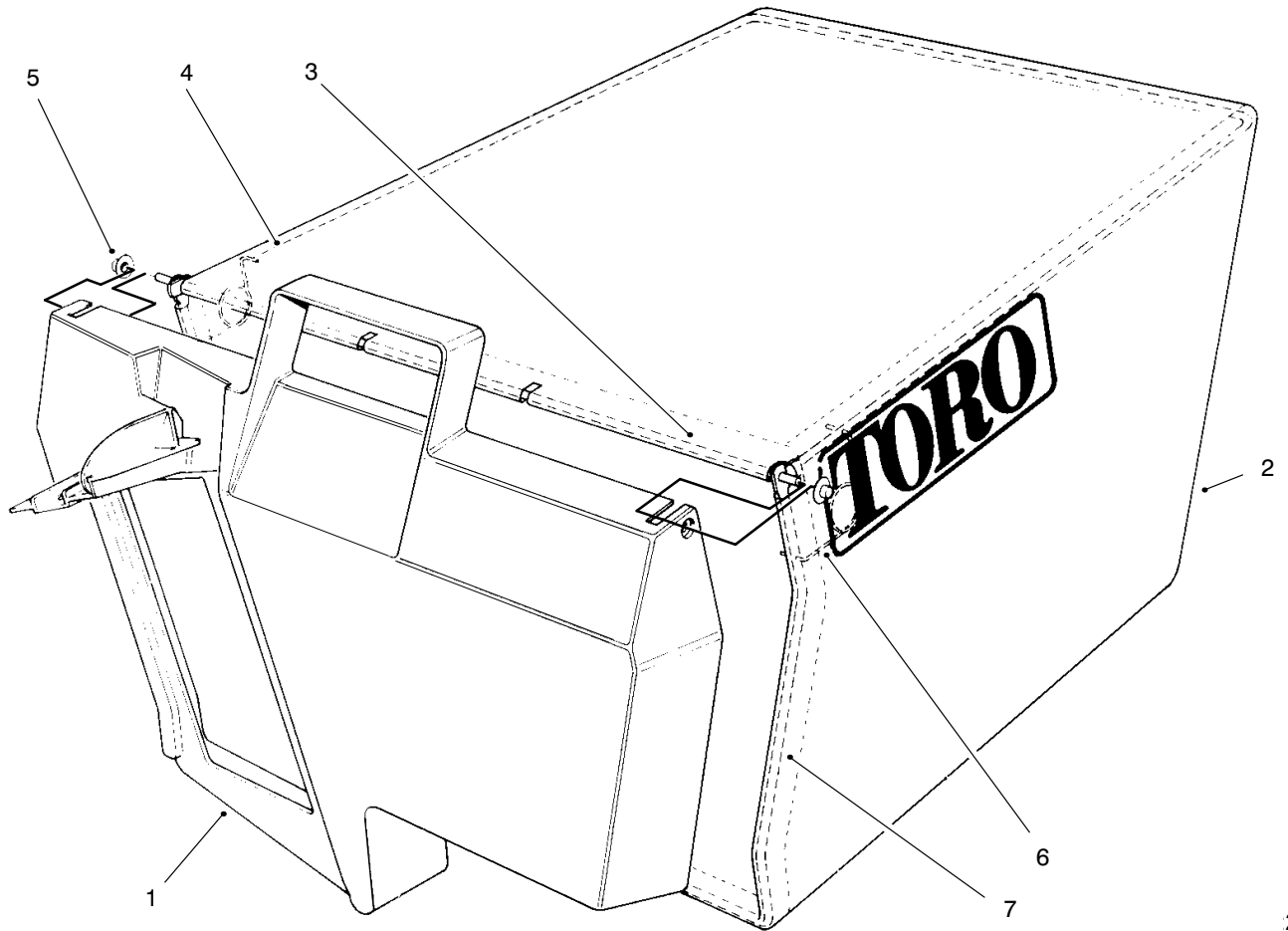

200

Grass Bag Assembly

Ref. No.	Part No.	Qty.	Description
0	11-0189	1	ASM-Bag
1	37-1393	1	Door-Bag
2	44-0522	1	Bag-Grass
3	33-4820	1	Hinge-Door
4	42-4030	1	Frame-Bag
5	3290-422	2	Nut-Push
6	36-6910	2	Spring
7	42-4020	1	Frame-Bag

Ref. No.	Part No.	Qty.	Description

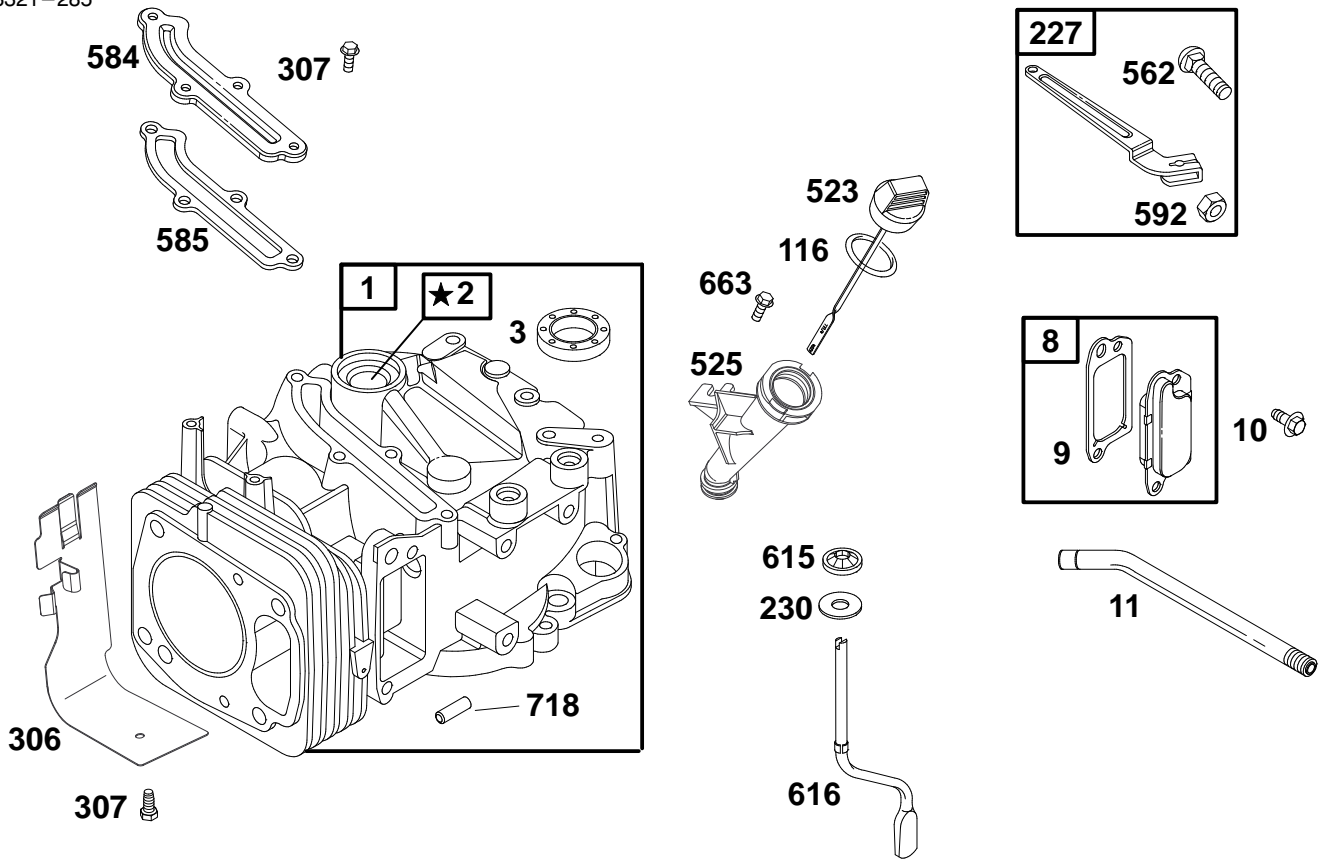

★ REQUIRES SPECIAL TOOLS TO INSTALL. SEE REPAIR INSTRUCTION MANUAL.

Assemblies include all parts shown in frames.

ENGINE GTS-200

Ref. No.	Part No.	Description	No. Used
1	99-0900	Cylinder Assembly	1
2	99-0911	Bushing	1
★3	99-0912	Seal - Oil	1
8	77-9260	Breather Assy.	1
†★9	99-0913	Gasket - Breather	1
10	99-0914	Screw - Hex.	1
11	99-0915	Tube - Breather	1
★116	99-0916	Seal - O Ring	1
227	99-0917	Lever Assembly - Gov.	1
230	99-0918	Washer - Gov. Crank	1
306	99-0919	Shield - Cylinder	1
307	99-0920	Screw - Hex.	1

★ Included in Gasket Set - Part No. 99-0902

Ref. No.	Part No.	Description	No. Used
523	77-7260	Dipstick	1
525	99-0906	Tube - Oil Filler	1
562	99-0921	Screw - Hex.	1
584	99-0922	Baffle - Cylinder	1
★585	99-0923	Gasket - Breather	1
592	99-0924	Nut - Hex.	1
615	99-0925	Fastener	1
616	99-0926	Crank - Governor	1
663	99-0927	Screw - Hex.	1
718	99-0928	Dowel - Sleeve	1

† Included in Valve Overhaul Gasket Set - Part No. 99-0904

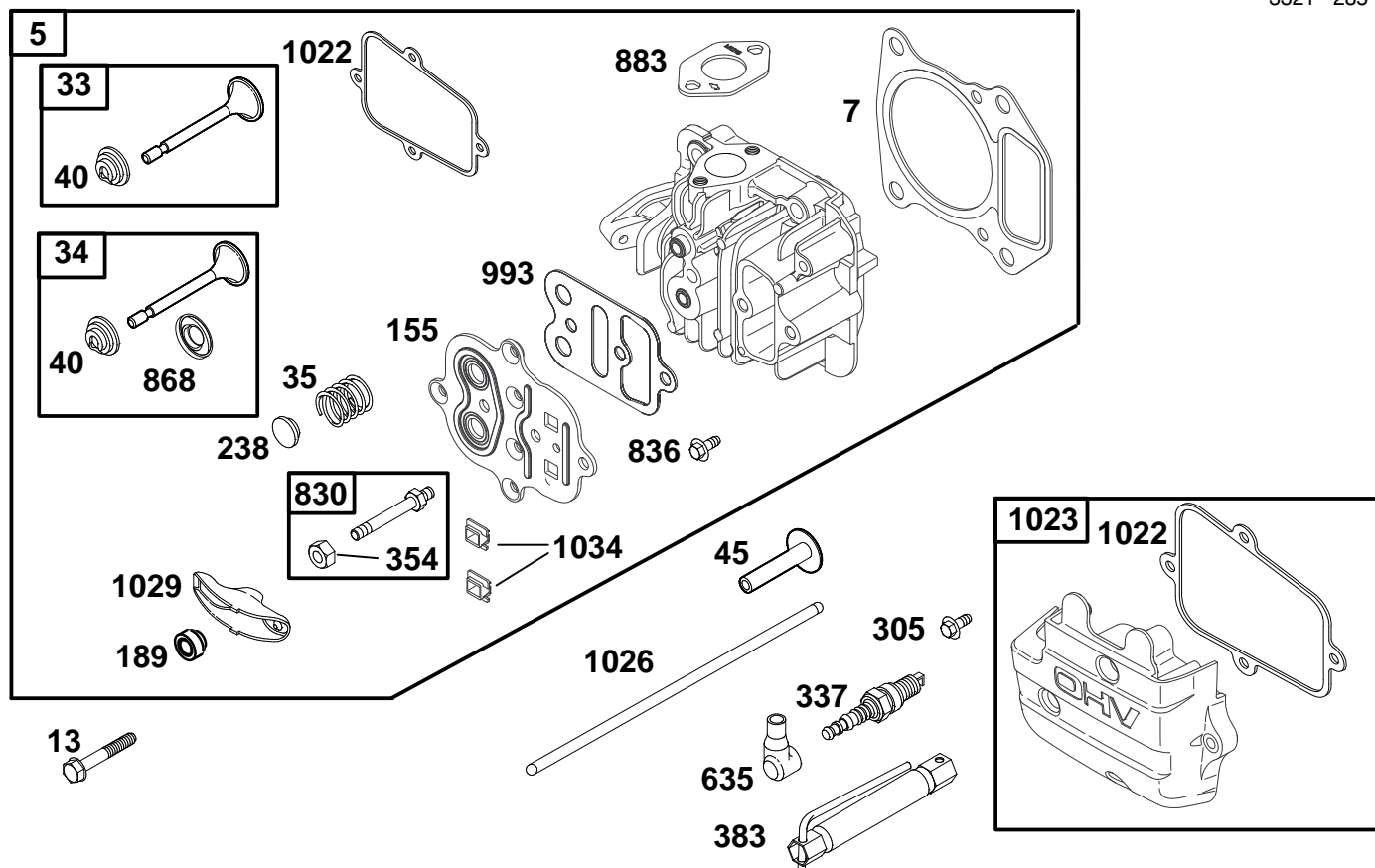

Assemblies include all parts shown in frames.

ENGINE GTS-200

Ref. No.	Part No.	Description	No. Used
5	99-0929	Head - Cylinder	1
†★7	99-0930	Gasket - Cylinder Head	1
13	99-0931	Screw - Hex.	1
33	99-0932	Valve - Exhaust	1
34	99-0933	Valve - Intake	1
35	99-0934	Spring - Valve	1
40	99-0935	Retainer - Valve Spring	1
45	99-0936	Tappet - Valve	1
155	99-0938	Plate - Cylinder Head	1
189	99-0939	Ball - Rocker Arm	1
238	99-0940	Cap - Valve	1
305	99-0942	Screw - Hex.	1
337	99-0943	Plug - Spark	1
354		Nut - Hex. (Sold in Kit Only)	1

Ref. No.	Part No.	Description	No. Used
383	99-0944	Wrench - Spark Plug	1
635	77-9190	Elbow - Spark Plug	1
830	99-0945	Stud - Rocker Arm	1
836	99-0941	Screw - Hex.	1
†★868	99-0946	Seal - Valve	1
†★883	99-0947	Gasket - Exhaust	1
†★993	99-0948	Gasket - Plate	1
†★1022	99-0907	Gasket - Rocker Cover	1
1023	98-9211	Cover - Rocker	1
1026	99-0949	Rod - Push	1
1029	99-0950	Arm - Rocker	1
1034	99-0951	Guide - Push Rod	1

★ Included in Gasket Set-Part No. 99-0902

† Included in Valve Overhaul Gasket Set-Part No. 99-0904

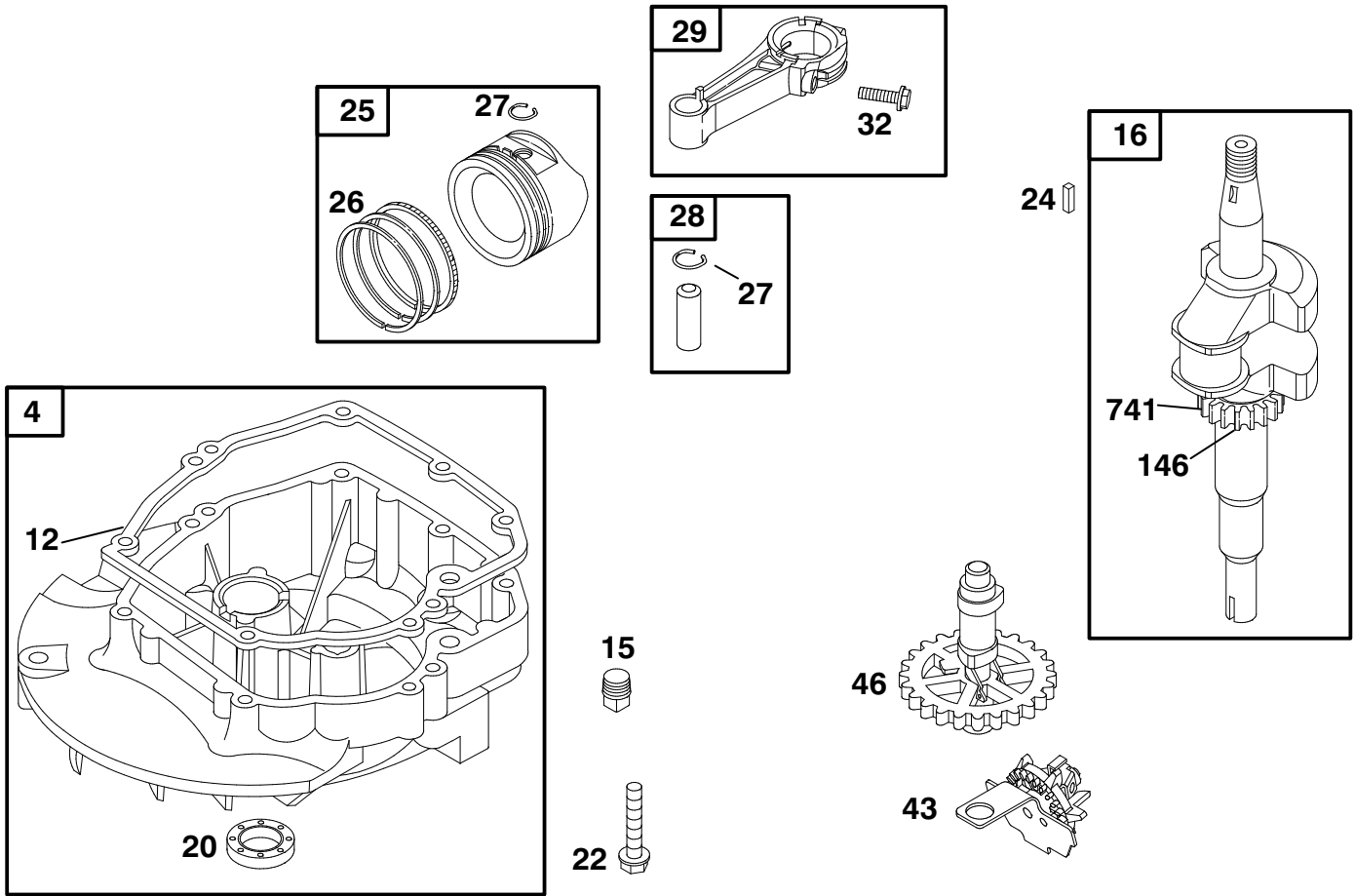

Assemblies include all parts shown in frames.

ENGINE GTS-200

Ref. No.	Part No.	Description	No. Used
4	99-0952	Sump - Engine	1
★12	99-0953	Gasket - Crankcase	1
15	99-0954	Plug - Oil Drain	1
16	98-9214	Crankshaft	1
★20	99-0955	Seal - Oil	1
22	99-0956	Screw - Hex.	1
		Note: 99-1040 Screw - Hex. (One (1) Used in Hole Nearest Breather.)	1
24	99-0957	Key - Flywheel	1

Ref. No.	Part No.	Description	No. Used
25	99-0958	Piston Assy. (Standard)	1
26	99-0959	Ring Set (Standard)	1
27	99-0960	Lock - Piston Pin	1
28	99-0961	Pin - Piston (Standard)	1
29	99-0962	Rod - Connecting	1
32	99-0963	Screw - Connecting Rod	1
43	99-0964	Governor/Oil Slinger	1
46	99-0965	Gear - Cam	1
146	99-0966	Key - Timing	1
741	99-0967	Gear - Timing	1

★ Included in Gasket Set - Part No. 99-0902

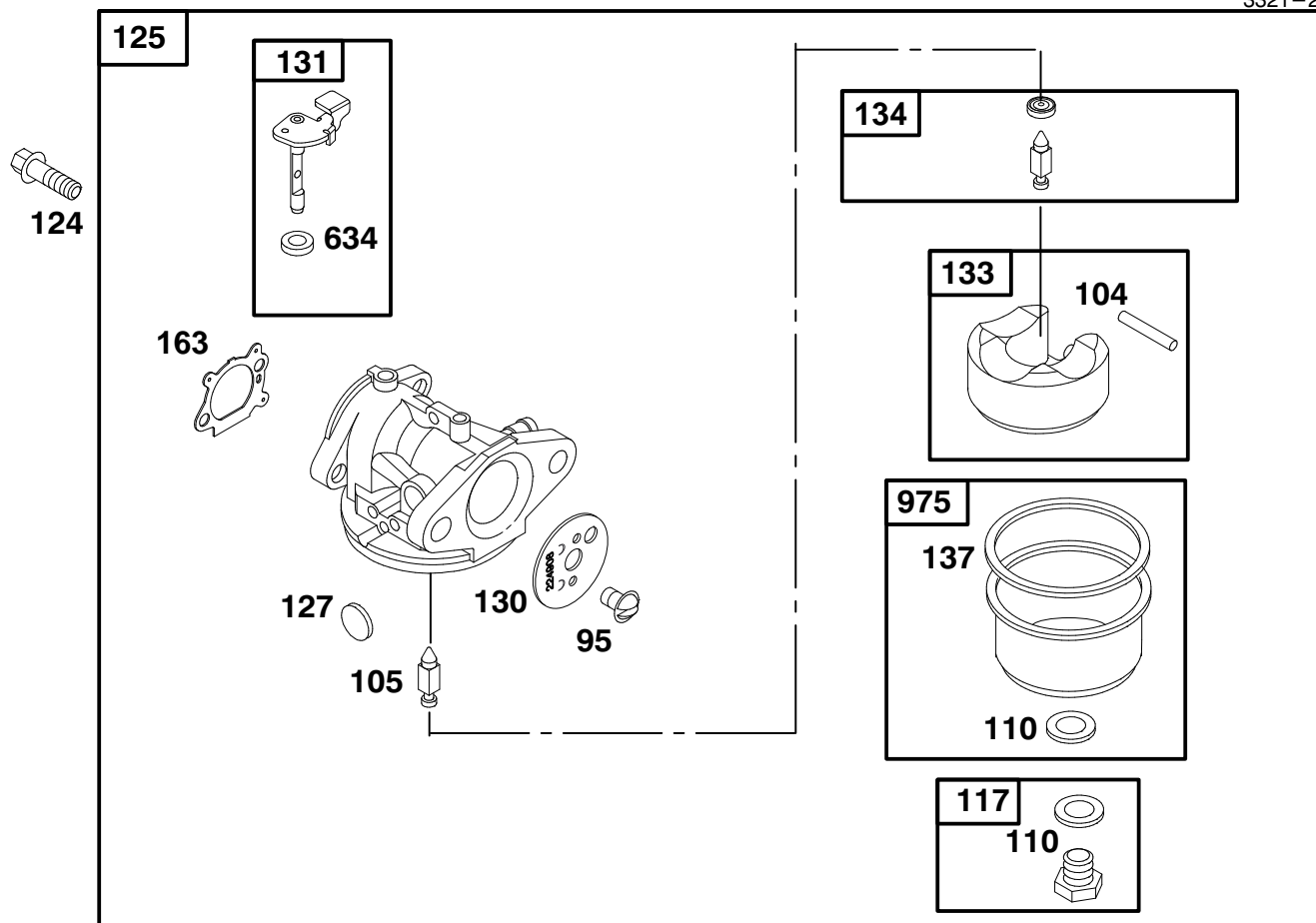

Assemblies include all parts shown in frames.

ENGINE GTS-200

Ref. No.	Part No.	Description	No. Used
95	99-0969	Screw - Slotted	1
●104	99-0970	Pin - Float Hinge	1
◆◆110		Washer - Bowl (Sold in Kit Only).	1
117	99-0971	Jet - Main (Std.) Note: 99-1041 Jet - Main (High Altitude)	1
124	99-0972	Screw - Shoulder	1
125	99-0973	Carburetor	1
●127		Plug - Welch (Sold in Kit Only).	1

Ref. No.	Part No.	Description	No. Used
130	99-0974	Valve - Throttle	1
131	99-0975	Shaft - Throttle	1
133	77-8170	Float - Carburetor	1
●134	77-8110	Valve - Needle	1
◆◆137		Gasket - Bowl (Sold in Kit Only).	1
◆◆*163	99-0976	Gasket - Air Cleaner	1
◆◆634		Washer - Foam (Sold in Kit Only).	1
975	99-0977	Bowl - Float	1

● Included in Carburetor Kit-Part No. 99-0901
◆ Included in Carburetor Gasket Set-Part No. 99-0903

* Included in Gasket Set-Part No. 99-0902
† Included in Valve Overhaul Gasket Set-Part No. 99-0904

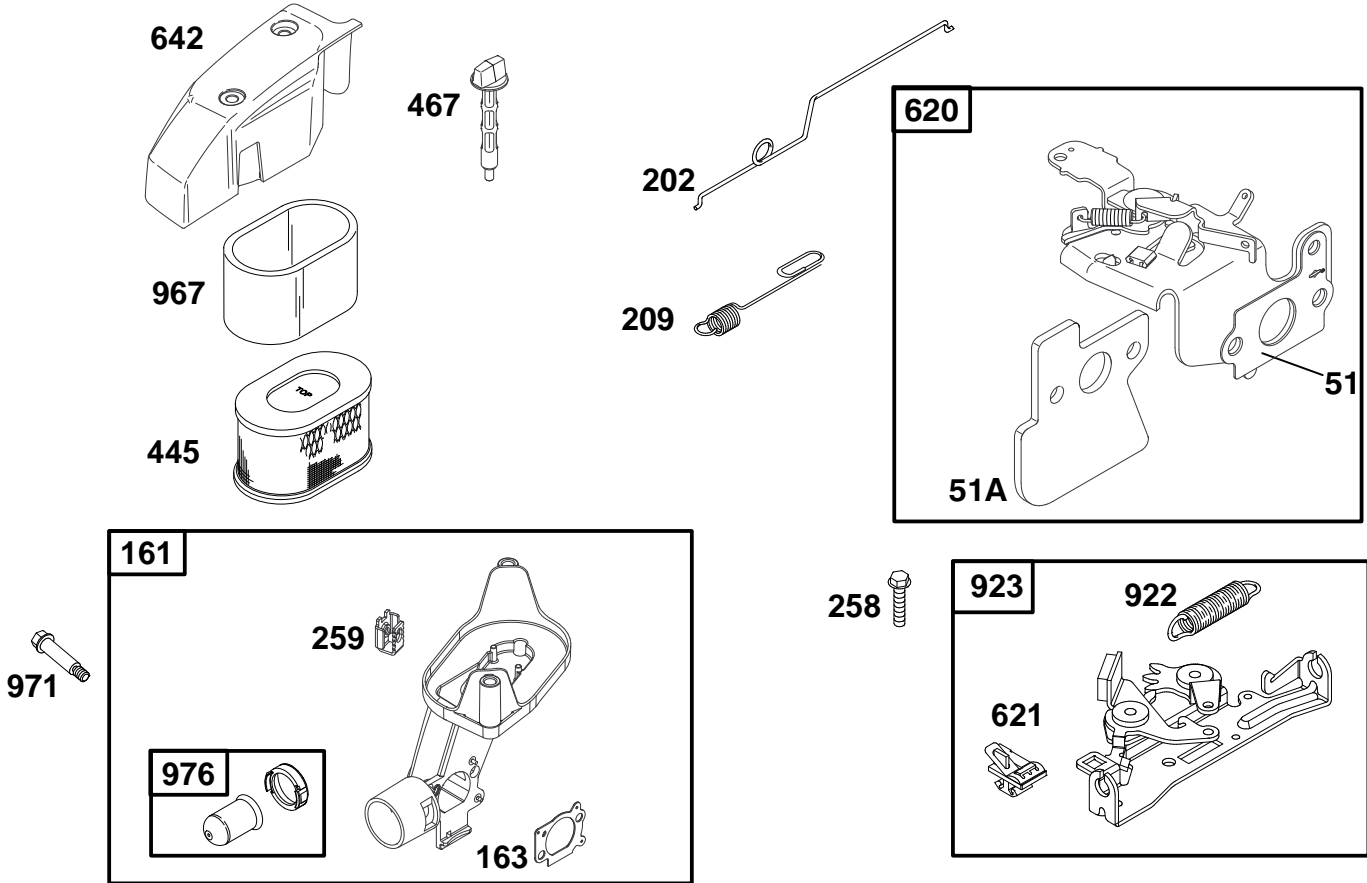

Assemblies include all parts shown in frames.

ENGINE GTS-200

Ref. No.	Part No.	Description	No. Used
51	99-0968	Gasket - Intake	1
51A	99-0978	Gasket - Intake	1
161	99-0979	Base - Air Cleaner/Primer	1
◆★163	99-0976	Gasket - Air Cleaner	1
202	99-0981	Link - Governor	1
209	99-0982	Spring - Governor	1
258	99-0983	Screw - Hex.	1
259	99-0984	Grommet	1
445	98-9212	Filter - Air	1

Ref. No.	Part No.	Description	No. Used
467	98-9208	Knob	1
620	99-0985	Bracket - Control	1
621	99-0986	Switch - Stop	1
642	98-9207	Cover - Air Cleaner	1
922	99-0987	Spring - Brake	1
923	99-0988	Brake Assembly	1
967	99-0989	Filter - Air	1
971	99-0990	Screw - Hex.	1
976	99-0991	Primer - Carburetor	1

◆ Included in Carburetor Kit - Part No. 99-0901
 ★ Included in Carburetor Gasket Set - Part No. 99-0903

★ Included in Gasket Set - Part No. 99-0902

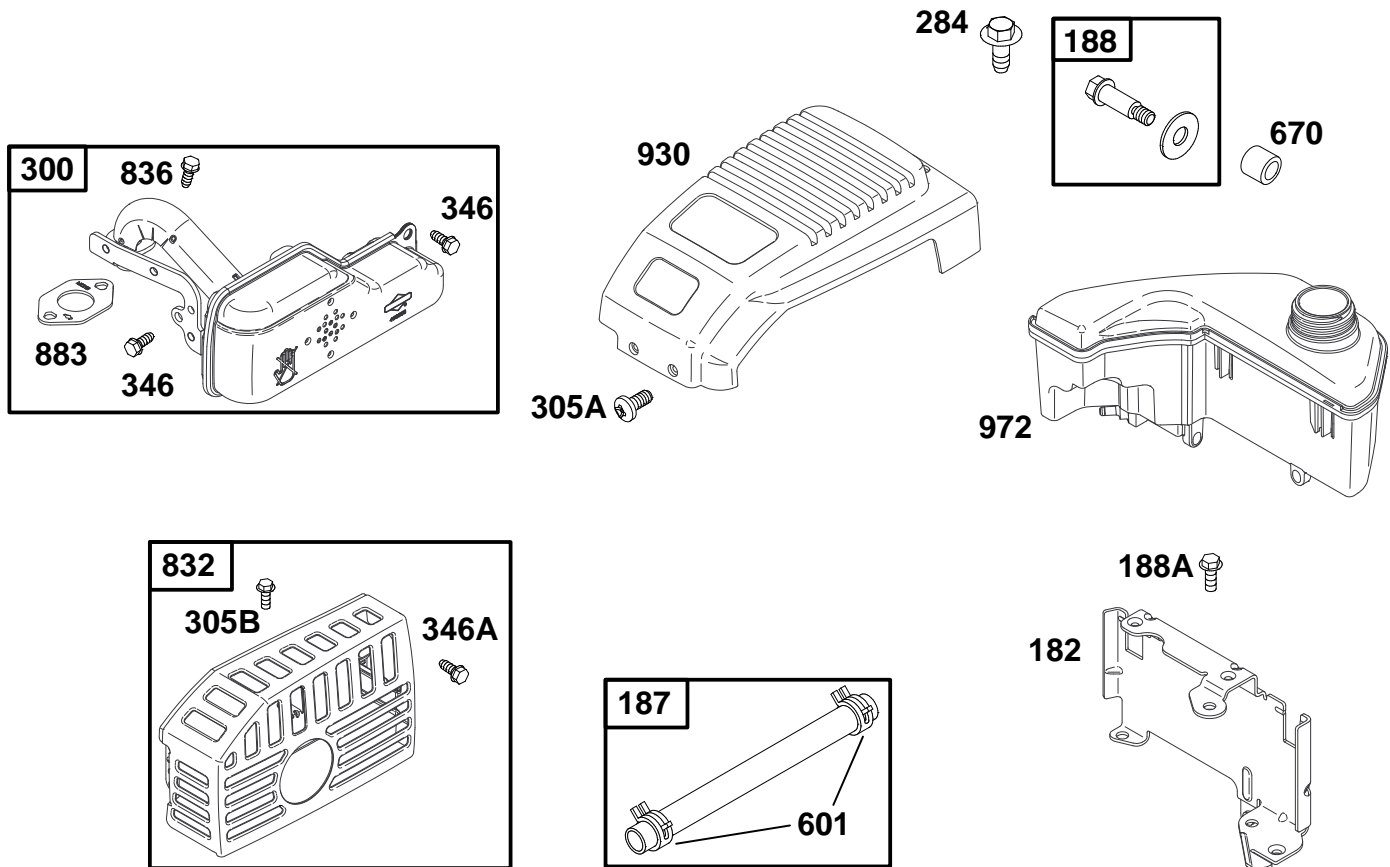

Assemblies include all parts shown in frames.

ENGINE GTS-200

Ref. No.	Part No.	Description	No. Used
182	98-9205	Bracket - Tank Mounting	1
187	99-0922	Line - Fuel (Cut to Required Length)	1
188	99-0993	Screw - Shoulder	1
188A	98-9202	Screw - Hex.	1
284	99-0994	Screw - Hex.	1
300	99-0995	Muffler - Exhaust	1
305A	98-9204	Screw - Torx®	1
305B	99-0998	Screw - Hex.	1

* Included in Gasket Set - Part No. 99-0902

Ref. No.	Part No.	Description	No. Used
346	99-1047	Screw - Hex.	1
346A	99-0999	Screw - Hex.	1
601	99-0996	Clamp - Hose	1
670	99-0997	Spacer - Fuel Tank	1
832	98-9206	Guard - Muffler	1
836	99-0941	Screw - Hex.	1
†*883	99-0947	Gasket - Exhaust	1
930	98-9203	Guard - Rewind	1
972	99-1000	Tank - Fuel	1

† Included in Valve Overhaul Gasket Set - Part No. 99-0904

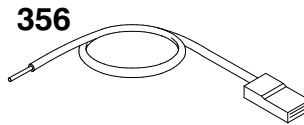
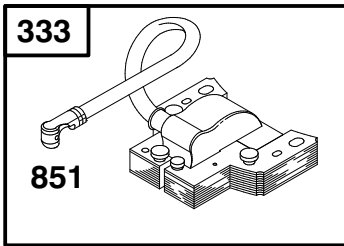
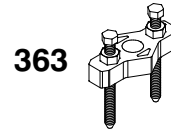
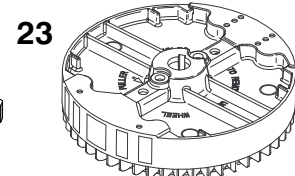
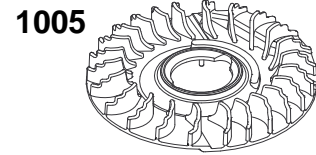
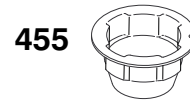
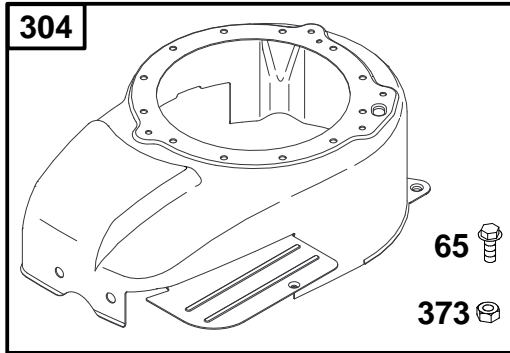
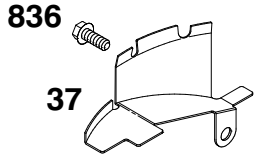

1036 LABEL KIT-EMISSION

Assemblies include all parts shown in frames.

ENGINE GTS-200

Ref. No.	Part No.	Description	No. Used
23	99-1001	Flywheel	1
37	99-0905	Guard - Flywheel	1
65	99-1002	Screw - Hex.	1
304	99-1003	Housing - Blower	1
332	99-1004	Nut - Flywheel	1
333	99-1005	Armature - Magneto	1
334	99-1006	Screw - Hex.	1
356	99-1007	Wire - Stop	1

Ref. No.	Part No.	Description	No. Used
363	99-1008	Puller - Flywheel	1
373	99-1009	Nut - Hex.	1
455	99-1010	Cup - Flywheel	1
836	99-0941	Screw - Hex.	1
851	77-9450	Terminal - Cable	1
1005	99-1015	Fan - Flywheel	1
1036	99-1016	Label Kit - Emission	1

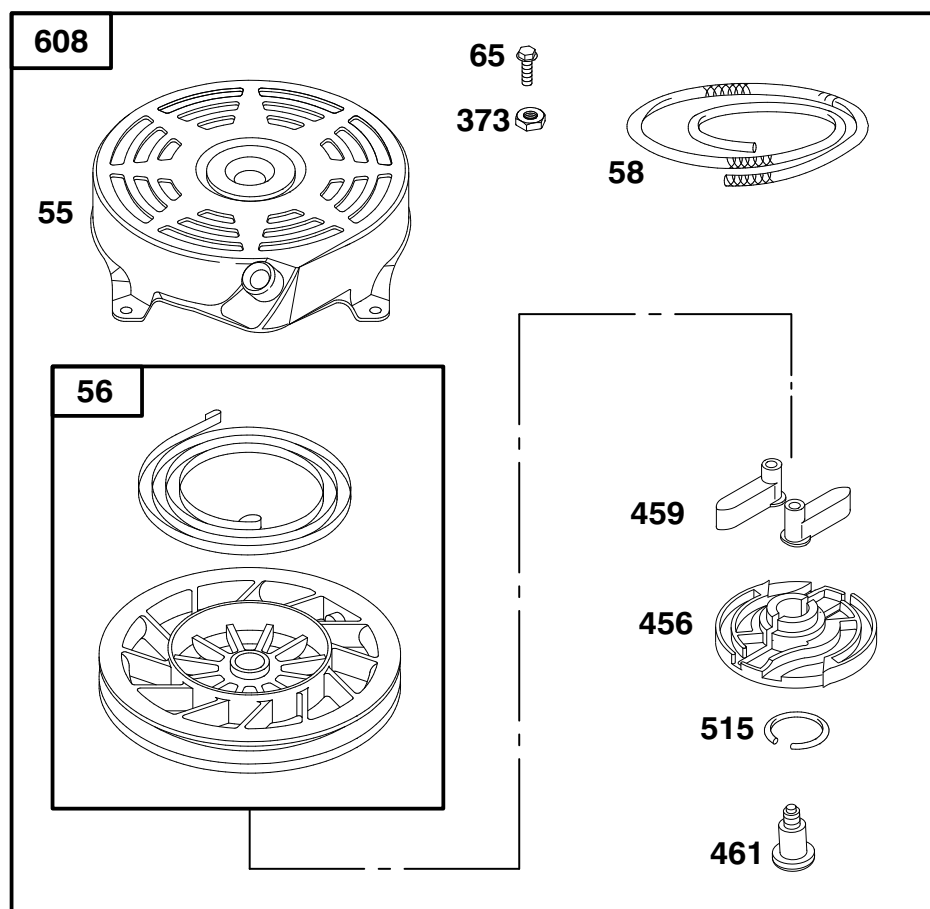

Assemblies include all parts shown in frames.

ENGINE GTS-200

Ref. No.	Part No.	Description	No. Used
55	99-1048	Housing - Rewind Starter	1
56	94-1657	Pulley - Starter	1
58	94-1668	Rope - Starter	1
59	77-7210	Insert - Starter Grip	1
60	77-8520	Grip - Starter Rope	1
65	99-1002	Screw - Hex.	1

Ref. No.	Part No.	Description	No. Used
373	99-1009	Nut - Hex.	1
456	94-1659	Retainer - Spring	1
459	94-1654	Pawl - Ratchet	1
461	94-1600	Screw - Shoulder	1
515	94-1655	Spring - Friction	1
608	98-9215	Starter - Rewind	1

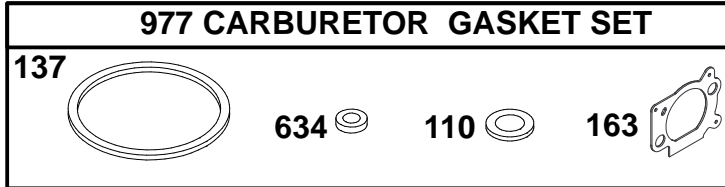
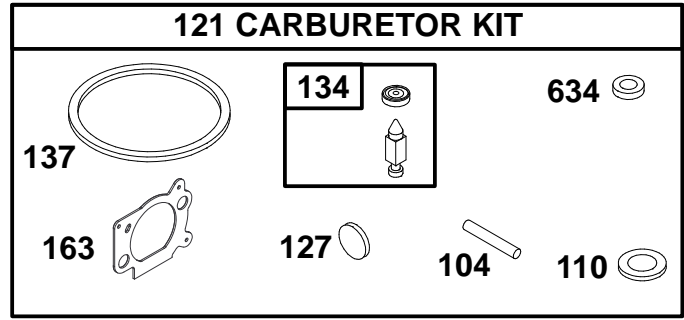
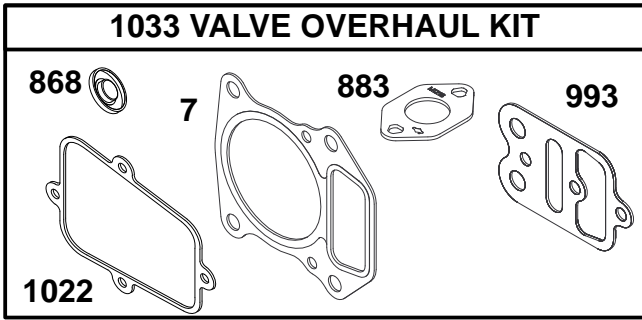
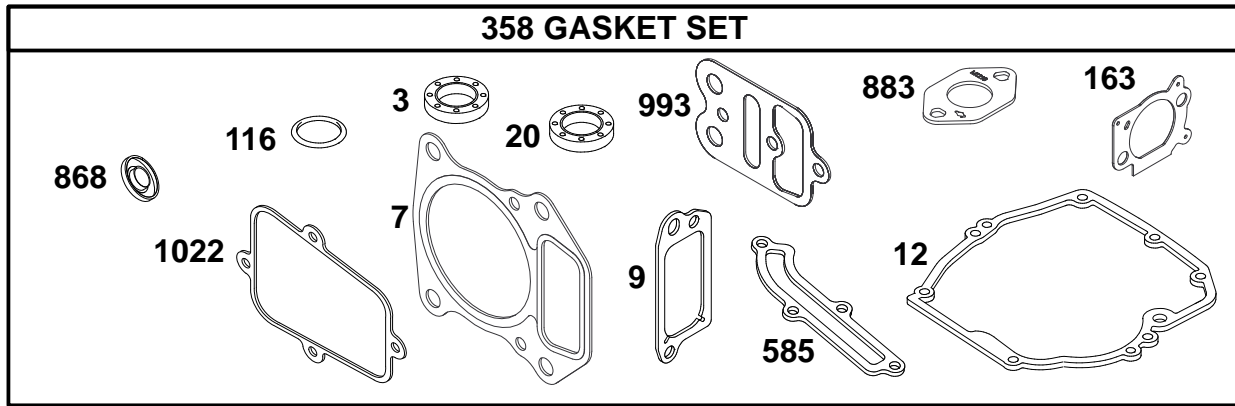

Assemblies include all parts shown in frames.

ENGINE GTS-200

Ref. No.	Part No.	Description	No. Used
★3	99-0912	Seal - Oil	1
†★7	99-0930	Gasket - Cylinder Head	1
†★9	99-0913	Gasket - Breather	1
★12	99-0953	Gasket - Crankcase	1
★20	99-0955	Seal - Oil	1
●104	99-0970	Pin - Float Hinge	1
◆◆110		Washer - Bowl (Sold in Kit Only).	1
★116	99-0916	Seal - O Ring	1
121	99-0901	Carburetor Kit	1
●127		Plug - Welch (Sold in Kit Only).	1
●134	77-8110	Valve - Needle	1
◆◆137		Gasket - Bowl (Sold in Kit Only).	1

Ref. No.	Part No.	Description	No. Used
◆◆★163	99-0971	Gasket - Air Cleaner	1
358	99-0902	Gasket Set	1
★585	99-0923	Gasket - Breather	1
◆◆634		Washer - Foam (Sold in Kit Only).	1
†★868	99-0946	Seal - Valve	1
†★883	99-0947	Gasket - Exhaust	1
977	99-0903	Gasket Set - Carburetor	1
†★993	99-0948	Gasket - Plate	1
†★1022	99-0907	Gasket - Rocker Cover	1
1033	99-0904	Gasket Set - Valve Overhaul	1

● Included in Carburetor Kit - Part No. 99-0901
 ◆ Included in Carburetor Gasket Set - Part No. 99-0903

★ Included in Gasket Set - Part No. 99-0902
 † Included in Valve Overhaul Gasket Set - Part No. 99-0904

Toro Part Number Index

Part No.	Page No.	Ref. No.	Qty.	Description
3-3287	5	5	2	Spacer
11-0189	6	0	1	ASM-Bag
14-9949	1	25	2	Wheel & Tire-ASM
14-9959	3	20	2	Wheel-ASM
19-4050	5	12	2	Knob
25-7740	1	21	2	Knob-Arm
25-7740	3	22	2	Knob-Arm
26-0670	2	15	1	Bolt-Blade
27-6232	1	26	2	Bolt-Wheel HH
27-6232	3	25	2	Bolt-Wheel HH
27-6250	1	25:1	4	Bushing
27-6250	3	20:1	4	Bushing
27-7210	5	4	2	Screw-Shoulder
27-7211	5	8	2	Screw-Shoulder
29-9570	4	21	1	Bushing-Yoke
33-3208	1	16	1	Rod-Shield
33-4820	6	3	1	Hinge-Door
36-4780	4	9	1	Washer-Thrust
36-4791	4	4	2	Washer-Thrust
36-6910	6	6	2	Spring
37-1393	6	1	1	Door-Bag
37-7260	1	31	2	Screw-TAP
38-7820	4	31	1	Bearing-Ball
40-1940	1	19	4	Washer
42-3520	3	5	2	Cap-End
42-4020	6	7	1	Frame-Bag
42-4030	6	4	1	Frame-Bag
43-1362	5	1	1	ASM-Handle
44-0522	6	2	1	Bag-Grass
44-0580	1	15	1	Shield-Trailing
46-5481	5	33	1	Cable-Traction
46-5520	5	24	1	Lever-Traction
46-6290	1	1:9	1	O-Ring
46-6440	5	34	1	Cover-Cables
46-6810	1	14	1	Screw HWH
46-6811	1	1:5	5	Screw-HWH
46-6980	5	27	1	Support-Cable
46-8090	1	36	2	Screw-Tapping
48-2060	3	8:2	2	Bearing-Needle
49-1630	5	23	2	Spacer-Support
49-2040	1	34	2	Screw-HH
49-2040	4	20	6	Screw-HH
52-7430	5	19	1	Bar-Control
55-3760	4	3	1	15 T Pinion
55-3770	4	11	1	Gear 49t 1st Gear
55-3780	4	2	1	Pinion 20t 2nd Gear
55-3790	4	12	1	Gear 44t 2nd Gear
55-3800	4	1	1	Pinion 25t 3rd Gear
55-3810	4	13	1	Gear 39t 3rd Gear
60-8710	4	18	1	Gearcase-Upper 3 Sp
60-8730	4	19	1	Cover-Gearcase
60-8750	4	5	2	Bushing
60-8770	4	8	1	Bushing-Output Shaft
60-8790	4	14	1	Sleeve-Gear
60-8800	4	17	1	Shaft-Intermediate
60-8810	4	22	1	Retainer-Shift-Fork
60-8821	3	2	1	Lever-Shift
60-8840	4	27	2	Pulley-Half
60-8850	4	32	1	Bushing-Output
60-8870	4	24	1	Yoke-Shift
60-8890	4	28	1	Gear-Pinion
62-3900	3	1	1	V-Belt

*Not Illustrated

Toro Part Number Index (cont.)

Part No.	Page No.	Ref. No.	Qty.	Description
62-4320	1	33	1	Bracket-Guide
62-6660	4	26	1	Spacer-Pulley
62-6673	1	32	1	ASM-Gearcase
62-6673	4		1	Gear Case Complete
62-7550	2	10	1	Pulley-Driver
63-8701	3	8	2	ASM
63-8721	3	6	2	ASM-Arm
65-2720	3	11	4	Ring-Retaining
65-4710	3	12	2	Ring-Friction
65-4720	3	17	2	Spring-Compression
65-4730	3	9	2	Washer-Thrust
65-4740	3	10	4	Washer-Thrust
65-4750	3	16	2	Gear-Pinion
65-4760	3	13	2	Washer
65-4770	4	23	1	Shaft-Output
65-5250	4	36	1	Clip-Spring
66-0541	1	20	2	ASM-Spring Arm
66-0560	1	24	2	Screw-Shoulder
66-0570	2	9	1	Guide-Belt
66-0580	1	23	2	Arm-Pivot
66-5351	5	20	1	Lever-Control
66-6040	3	15	1	Key-Locking RH
66-6050	3	14	1	Key-Rocking LH
70-9760	3	8:5	2	Bushing
71-9350	1	38	1	Spring-Bracket
74-1660	3	18	2	Cover-Wheel
74-1671	3	19	2	Spacer-Cover
76-0760	4	38	2	Key-Shift
76-0770	4	34	1	Collar-Shift
76-0780	4	37	1	Sleeve-Shift Key
76-2712	5	30	1	Control-Speed
76-4331	5	32	1	Cable-Brake
76-4640	1	3:2	1	Latch Discharge Plug
76-4650	1	3:4	1	Grip Latch
76-4660	1	35	1	Spring-Extension
77-0502	1	3	1	ASM-Plug
80-3770	1	12	1	Retainer-Door
82-5680	1	27	1	Bracket-Adjustment
82-8780	3	4	1	Retainer-Cable
82-9151	1	10	1	Tunnel-Discharge
84-8361	5	2	1	Latch-Handle
84-8401	5	3	1	Latch-Handle
86-9671	5	29	1	Guide-Rope
92-1720	1	1:2	1	Kicker-RH
92-1730	1	1:3	1	Kicker-LH
92-1750	1	1:1	1	Plate-Kicker Rear
92-2260	5	11	4	Screw-Handle
92-2269	5	26	1	Screw-Handle
92-2289	2	3	1	Plate-Logo
92-7663	3	21	1	Cover-Wheel
92-7859	5	13:3	1	Decal-Panel
92-9665	5	18	5	Screw-Phil
93-3154	1	11	1	Plate-Latch
93-4106	2	12	1	Blade-Generation Iii
93-4107	2	11	1	Retainer-Blade
93-6655	5	13:1	1	Decal-Danger
93-7198	2	2	1	ASM-Cap
93-7351	1	37	1	ASM-Door
93-8470	2	7	1	Screw-Clamp
94-1608	2	13	1	Stiffener-Blade
94-4922	5	9	1	ASM-Handle
94-5407	1	2	1	Decal-Deck

*Not Illustrated

Toro Part Number Index (cont.)

Part No.	Page No.	Ref. No.	Qty.	Description
95-2747	1	1:8	1	Fitting-Washout
95-5615	1	1	1	Housing-Rwd
98-1501	5	31	1	Control-Throttle
98-1502	1	30	1	Cover-Belt
98-2004	2	4	1	Decal-Engine
98-2020	5	13:2	1	Decal-Instruction
98-9232	5	13	1	Panel-Control
2210-249	2	6	1	Clamp-Casing
2210-316	2	5	1	Rope-Stop
237-153	3	7	2	O-Ring
2412-50	5	35	3	Clip-Tubing
302-56	3	8:4	2	Fitting-Grease
321-39	5	21	1	Screw-HH
3253-22	2	14	1	Washer-Lock
3256-1	5	28	1	Washer-Flat
3256-24	4	30	1	Washer-Flat
3272-10	3	3	1	Pin-Cotter
3290-378	5	36	4	Tie-Cable
3290-422	6	5	2	Nut-Push
3295-35	1	3:3	1	Rivet Solid
3296-5	4	29	1	Nut-Lock
3296-6	1	18	4	Nut-Lock
3296-6	3	24	2	Nut-Lock
3296-47	5	6	1	Nut-Lock
3296-72	5	7	3	Nut-Lock
3296-73	5	22	3	Nut-Lock
3296-74	5	25	2	Nut-Flange
32121-120	4	15	1	Pin-Coil
32144-70	1	1:6		Screw-TAP
32144-70	1	28		Screw-TAP
32144-70	2	17		Screw-TAP
32144-70	3	26	1	Screw-TAP
32144-85	1	22	2	Screw-HH
32144-85	3	23	2	Screw-HH
32144-102	2	8	3	Screw
32144-111	1	1:4	6	Screw - PPH

MAINTENANCE RECORD

Date								

MAINTENANCE RECORD

Date								

MAINTENANCE RECORD

Date								