



Heat Shield Kit

TimeCutter® Riding Mower

Model No. 137-7065

Installation Instructions

⚠ WARNING

CALIFORNIA Proposition 65 Warning

This product contains a chemical or chemicals known to the State of California to cause cancer, birth defects, or reproductive harm.

Loose Parts

Use the chart below to verify that all parts have been shipped.

Description	Qty.	Use
Heat shield	1	Install the kit.
Bolt	4	

Installing the Kit

1. Park the machine on a level surface, shut off the engine, engage the parking brake, and remove the key.
2. Wait for the machine to cool completely.
3. Remove and discard the 2 bolts and heat shield shown in [Figure 1](#).

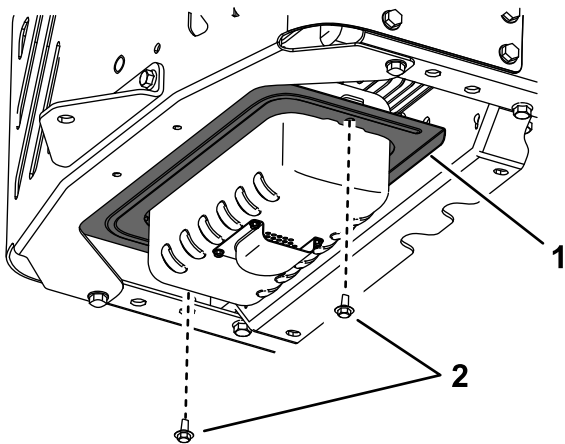

Figure 1

1. Heat shield
2. Bolt

g224576

4. Secure the rear of the heat shield using 2 bolts in the existing holes in the rear bumper ([Figure 2](#)).

Note: Ensure that the cutout of the shield faces rearward.

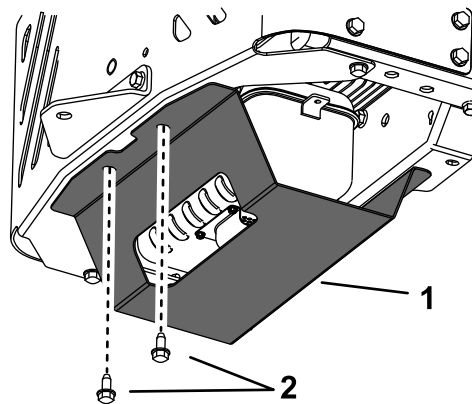

Figure 2

1. Heat shield
2. Bolt

g224575

5. Using the heat shield as a template, drill 2 holes (7 mm or 9/32 inch) into the cross bracket ([Figure 3](#)).

Important: Ensure that you do not drill into the belt above the cross bracket.



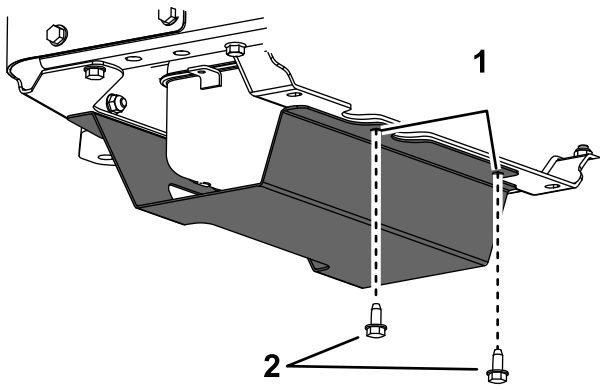

g224592

Figure 3

1. Drill here. 2. Bolt

-
6. Secure the front of the heat shield using 2 bolts in the holes that you drilled ([Figure 3](#)).