



**Count on it.**

**Parts Catalog**

**20in Recycler<sup>®</sup>/Rear Bagging  
Lawn Mower**

Model No. 20319—Serial No. 313000001 and Up



# Ordering Replacement Parts

To order replacement parts, please supply the part number, the quantity, and the description of each part desired.

## Understanding Reference Numbers

Each identified part in an illustration has a reference number. The reference number for a part also appears in the parts list, along with other information about the part.

This catalog uses two special reference number formats, one to indicate parts in a service assembly and another to indicate the quantity of a given part in an illustration.

## Service Assembly Reference Numbers

Parts in service assemblies have reference numbers in the form a:b. The a represents the reference number of the entire service assembly and the b represents a sequential number unique to each part within the service assembly.

For example, a wheel assembly might be identified by reference number 6, the tire by 6:1, the valve by 6:2, and the wheel by 6:3. When you order the assembly identified by reference number 6, you receive all parts identified by reference numbers 6:1, 6:2, and 6:3. However, you may also order any part individually. Reference numbers of this type appear in illustration and in parts lists.

## Reference Numbers Indicating Quantity

In an illustration, if a reference number indicates more than one part, the reference number has the form nX y. The n represents the quantity of the part, the X is the multiplication symbol, and the y represents the reference number.

For example, in an illustration, the reference number 2X 37 means that two of the parts identified by reference number 37 are indicated.

# Contents

Deck and Rear Door Assembly .....	4
Engine and Blade Assembly .....	5
Front Wheel and Height-of-Cut Assembly .....	6
Rear Wheel and Height-of-Cut Assembly .....	7
Handle Assembly .....	8
Attachments and Accessories .....	9

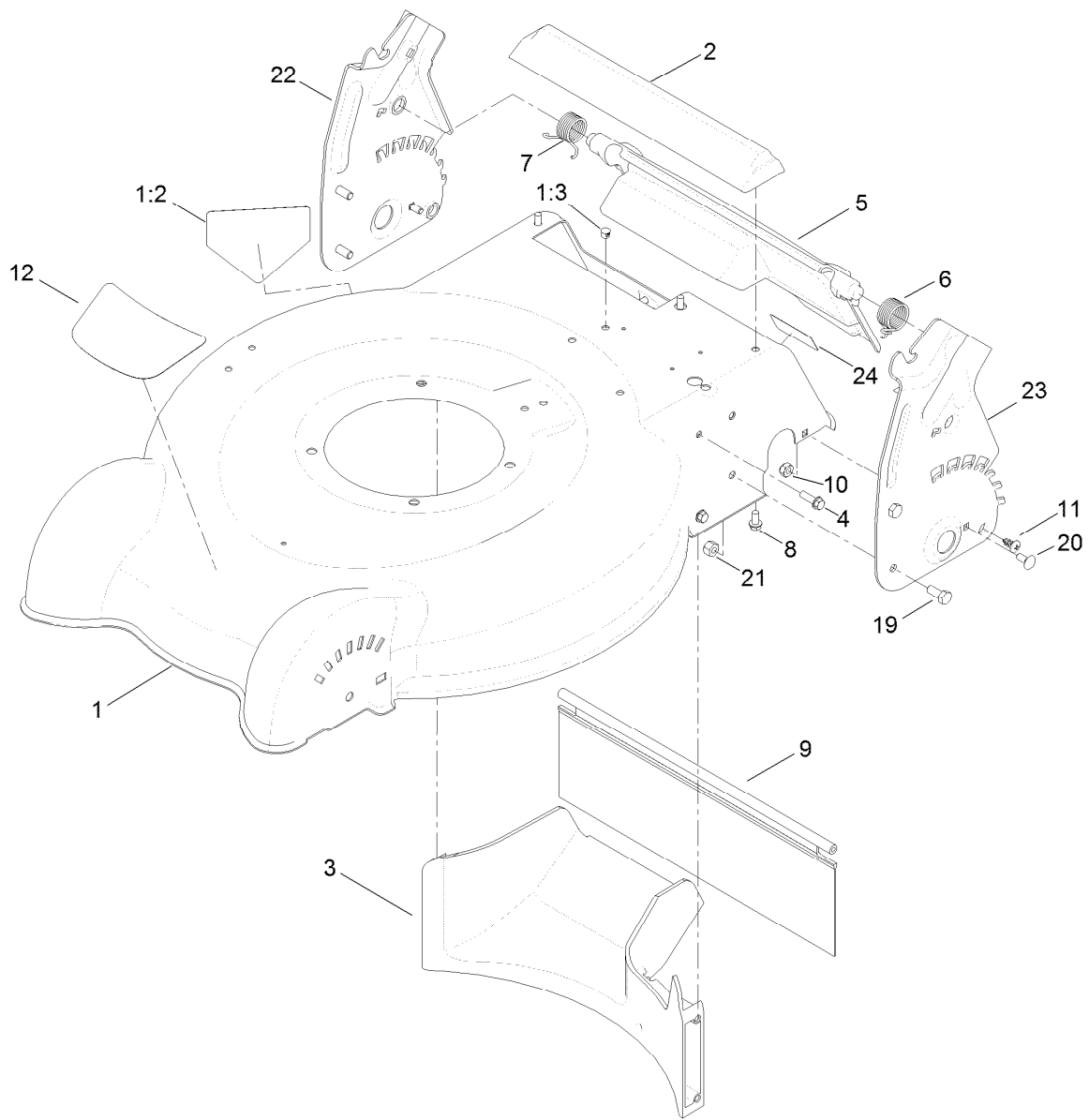

## Deck and Rear Door Assembly

<i>Ref.</i>	<i>Part Number</i>	<i>Qty.</i>	<i>Description</i>	<i>Ref.</i>	<i>Part Number</i>	<i>Qty.</i>	<i>Description</i>
1	120-9482	1	Housing ASM	10	3296-16	2	Nut-Lock, NI
1:2	94-8072	1	Decal-Danger	11	117-1092	2	Screw-PTH
1:3	104-9373	1	Plug-Dome	12	119-7008	1	Decal-Deck
2	112-8845	1	Chute-Rear	19	322-3	4	Screw-HH
3	112-8814	1	Baffle-Rear	20	3229-11	2	Screw-CARR
4	46-8091	5	Screw-HWH	21	3296-29	4	Nut-Lock, NI
5	119-7029	1	Rear Deflector ASM	22	112-8822-03	1	Plate-HOC, LH
6	119-7015	1	Spring-Torsion, LH	23	112-8823-03	1	Plate-HOC, RH
7	119-7016	1	Spring-Torsion, RH	24	121-5684	1	Decal-Location, Service Dealer
8	46-8093	3	Screw-Plastite				
9	125-2517	1	Shield-Trailing				

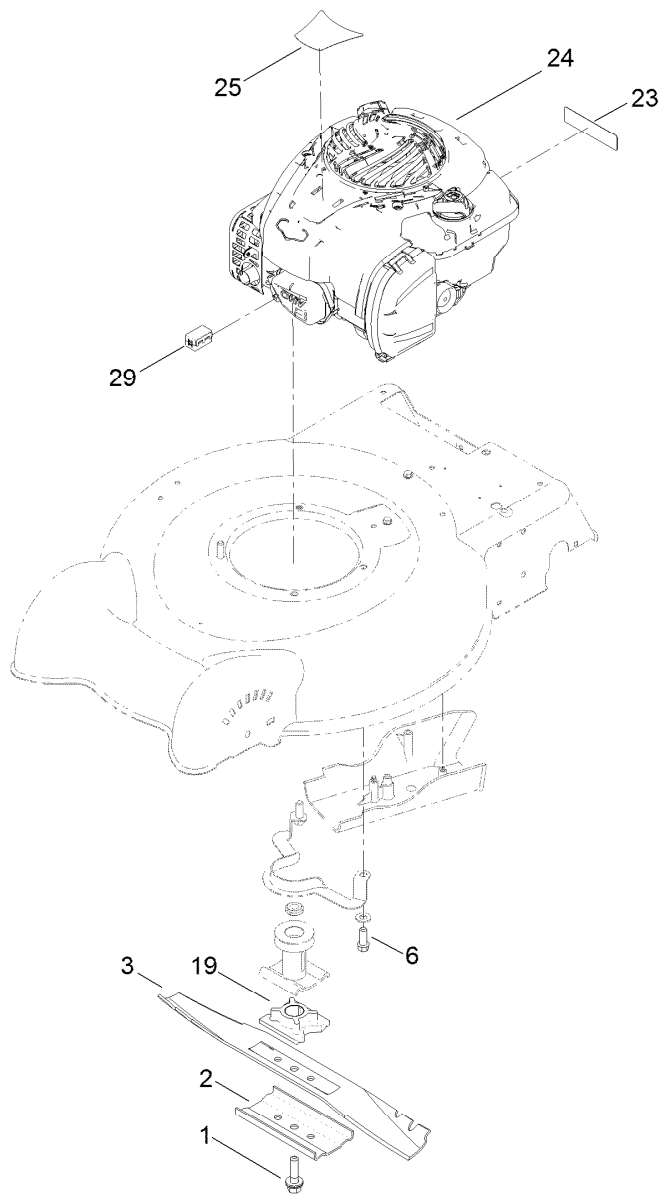

## Engine and Blade Assembly

Ref.	Part Number	Qty.	Description
1	117-5270	1	Bolt-Blade
2	108-3766-03	1	Support-Blade
3	112-8841-03	1	Blade-20 Inch
6	95-1726	3	Screw-Taptite
19	125-2454	1	Retainer-Blade
23	117-2718	1	Decal-Arrester, Spark
24		1	Engine-Briggs, 09P7020098F1 ● ■
25	127-0653	1	Decal-Engine
29	125-5054	1	Ferrite-Clamp

● Not serviced separately

■ Obtain parts from [www.briggsandstratton.com](http://www.briggsandstratton.com)

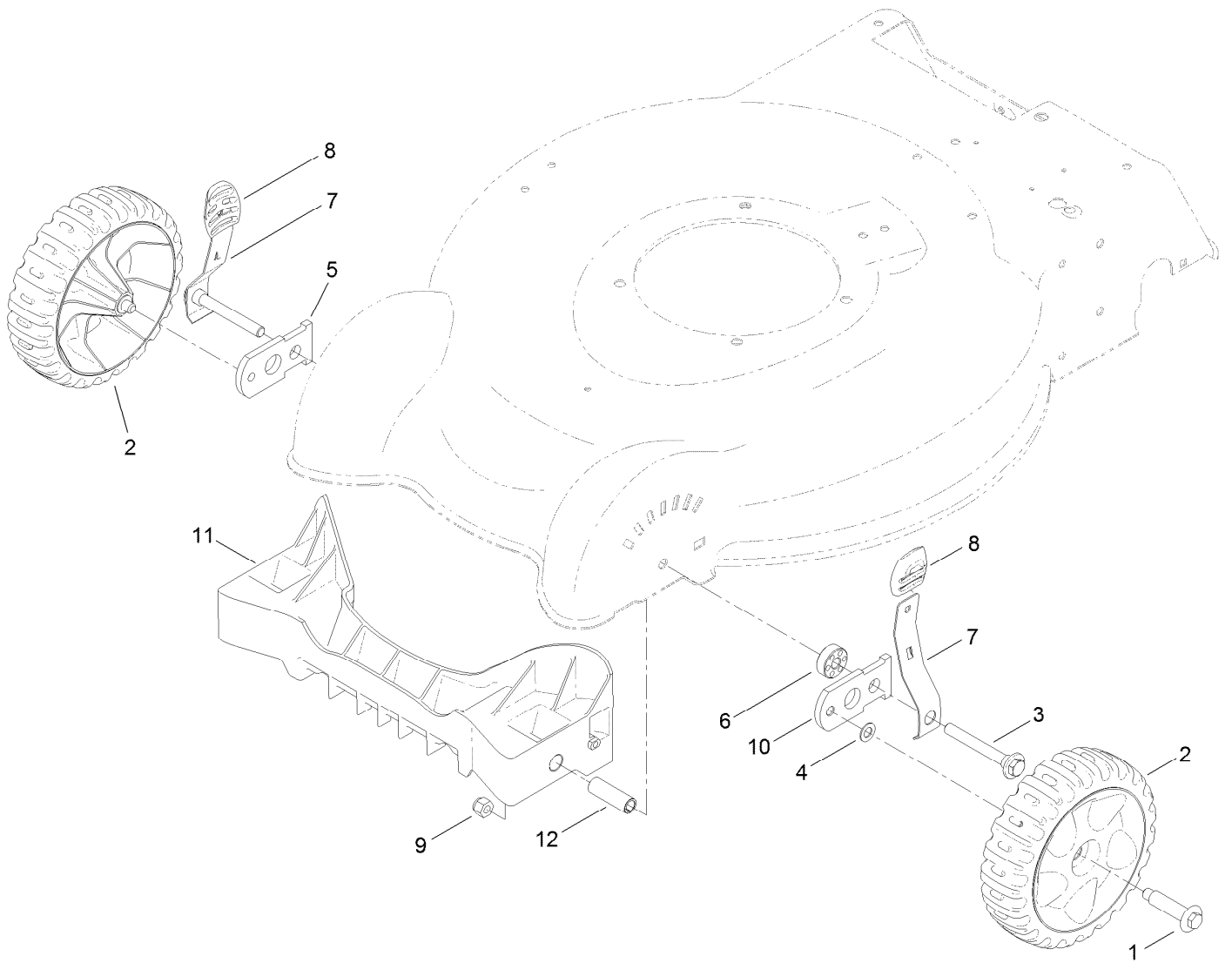

## Front Wheel and Height-of-Cut Assembly

Ref.	Part Number	Qty.	Description
1	614650	2	Bolt-Shoulder
2	119-3777	2	7 Inch Wheel And Tire ASM
3	117-5996	2	Bolt-Shoulder
4	40-1940	2	Washer
5	107-3877	1	Arm-Pivot, RH
6	117-5997	2	Spacer-Arm, Pivot
7	112-8828	2	Arm-Spring, Front
8	105-3042	2	Knob-Lever, HOC
9	3296-39	2	Nut-Lock, NI
10	108-1044	1	Arm-Pivot, LH
11	119-7082	1	Baffle-Throw, Front
12	117-5992	2	Spacer-Baffle, Front

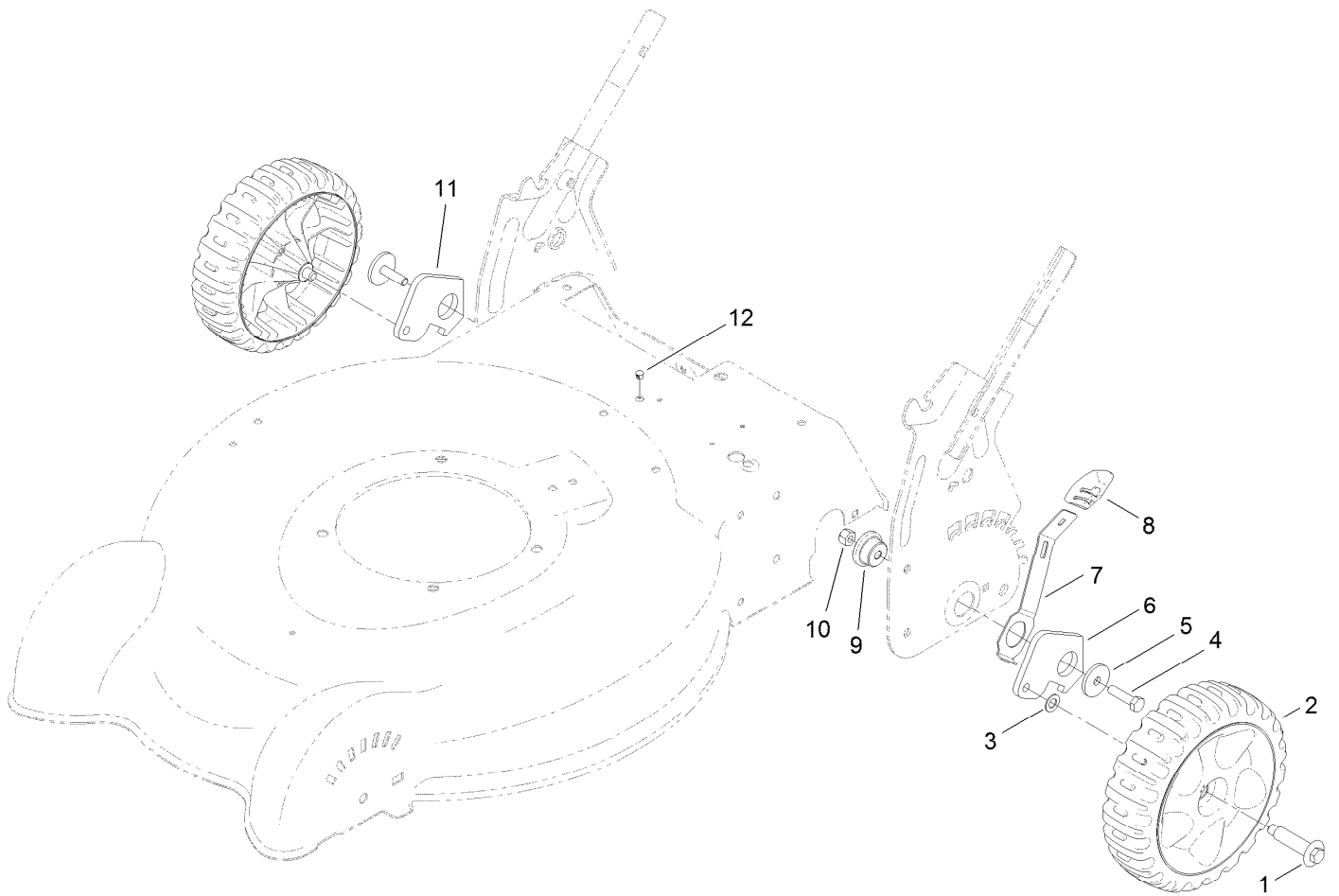

## Rear Wheel and Height-of-Cut Assembly

<i>Ref.</i>	<i>Part Number</i>	<i>Qty.</i>	<i>Description</i>
1	614650	2	Bolt-Shoulder
2	117-5995	2	8 Inch Wheel And Tire ASM
3	40-1940	2	Washer
4	322-6	2	Screw-HH
5	105-3048	2	Washer-Flat
6	105-1819	1	Arm-Pivot, Rear (LH)
7	105-1809	2	Arm-Spring
8	105-3042	2	Knob-Lever, HOC
9	105-1818	2	Bushing-Mount, HOC
10	3296-29	6	Nut-Lock, NI
11	108-4816	1	Arm-Pivot, Rear (RH)
12	104-9373	5	Plug-Dome

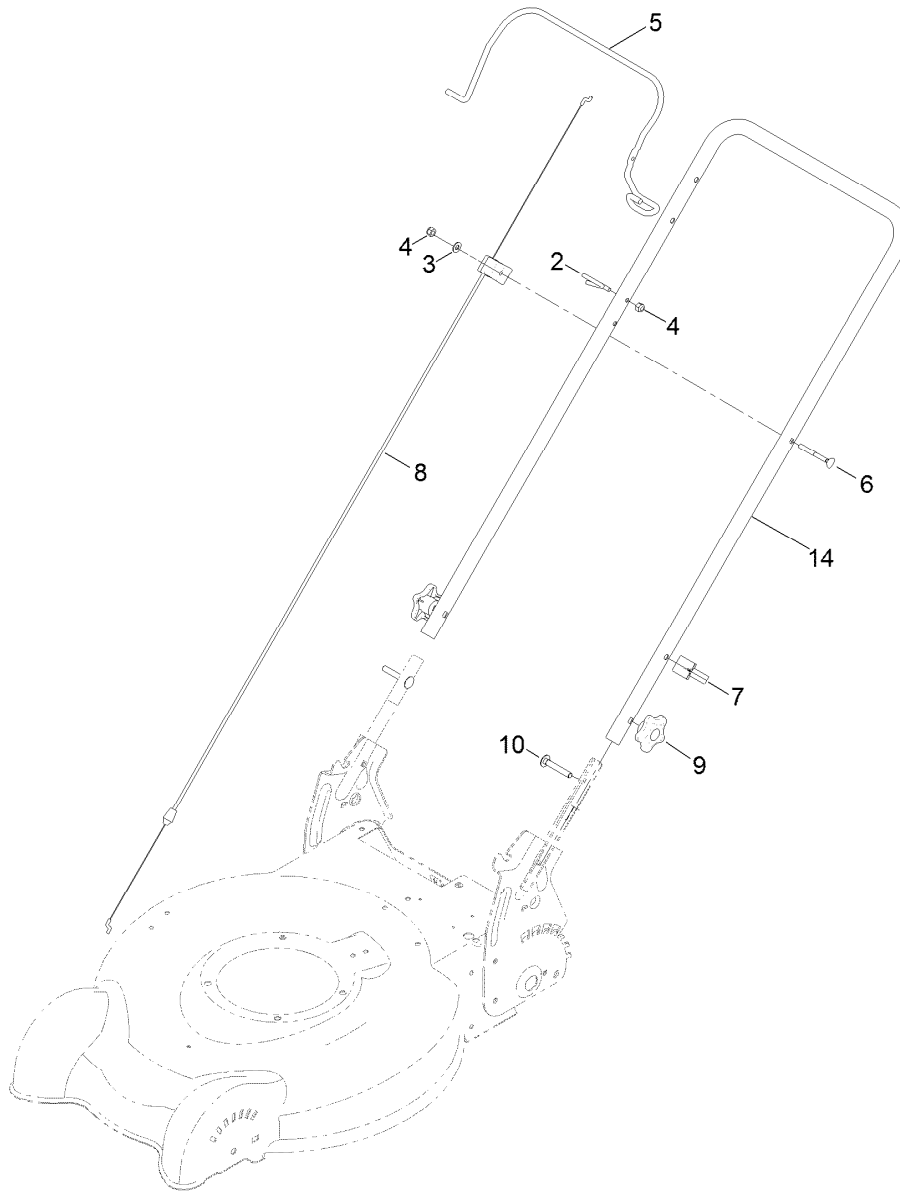

## Handle Assembly

<b>Ref.</b>	<b>Part Number</b>	<b>Qty.</b>	<b>Description</b>
2	86-9671	1	Guide-Rope
3	3256-1	1	Washer-Flat
4	3296-73	2	Nut-Lock, NI
5	117-5940-03	1	Bail-Brake
6	92-2270	1	Screw-Handle
7	114-7988	1	Guide-Cable
8	125-2524	1	Cable-Brake, Engine
9	117-5976	2	Knob-Handle
10	3230-6	2	Screw-CARR
14	120-9528-05	1	Handle



# Attachments and Accessories

## For 20319 20in Recycler/Rear Bagging Lawn Mower

<b>Product Name</b>	<b>Model/Part</b>
Briggs 550 Maintenance Kit .....	130-8147
Lawnmower Cover .....	490-7462
Rear-Discharge Deflector, 2009 and After 20in Steel Deck Mower .....	89964

**Notes:**

**Notes:**



**Count on it.**