



HoverPro® 400 Machine

Model No. 02615—Serial No. 314000001 and Up

Operator's Manual

Introduction

WARNING

CALIFORNIA

Proposition 65 Warning

This product contains a chemical or chemicals known to the State of California to cause cancer, birth defects, or reproductive harm.

The engine exhaust from this product contains chemicals known to the State of California to cause cancer, birth defects, or other reproductive harm.

It is a violation of California Public Resource Code Section 4442 or 4443 to use or operate the engine on any forest-covered, brush-covered, or grass-covered land unless the engine is equipped with a spark arrester, as defined in Section 4442, maintained in effective working order or the engine is constructed, equipped, and maintained for the prevention of fire.

This spark ignition system complies with Canadian ICES-002.

The enclosed *Engine Owner's Manual* is supplied for information regarding the US Environmental Protection Agency (EPA) and the California Emission Control Regulation of emission systems, maintenance, and warranty. Replacements may be ordered through the engine manufacturer.

Read this information carefully to learn how to operate and maintain your product properly and to avoid injury and product damage. You are responsible for operating the product properly and safely. Keep for future reference.

You may contact Toro directly at www.Toro.com for product and accessory information, help finding a dealer, or to register your product.

Whenever you need service, genuine Toro parts, or additional information, contact an Authorized Service Dealer or Toro Customer Service and have the model and serial numbers of your product ready. [Figure 1](#) identifies the location of the model and serial numbers on the product.

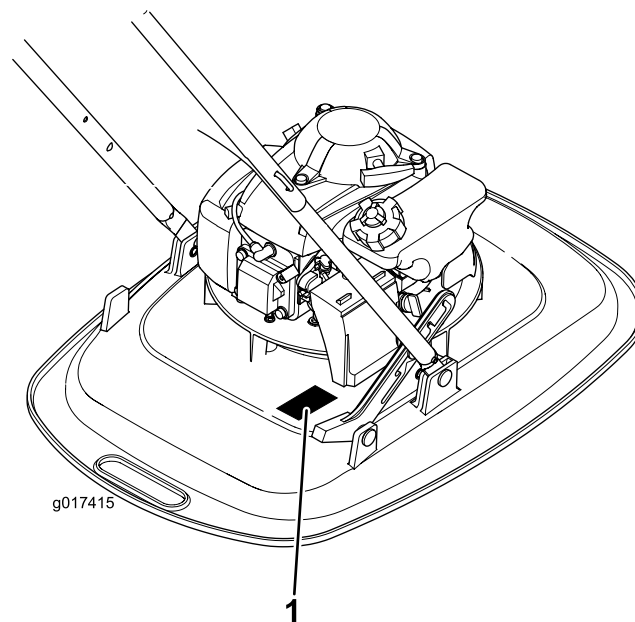

Figure 1

1. Model and serial number plate

Write the product model and serial numbers in the space below:

Model No.	_____
Serial No.	_____

This manual identifies potential hazards and has safety messages identified by the safety alert symbol ([Figure 2](#)), which signals a hazard that may cause serious injury or death if you do not follow the recommended precautions.



Figure 2

1. Safety alert symbol

This manual uses 2 words to highlight information. **Important** calls attention to special mechanical information and **Note** emphasizes general information worthy of special attention.



For models with stated engine horsepower, the gross horsepower of the engine was laboratory rated by the engine manufacturer in accordance with SAE J1349. As configured to meet safety, emission, and operating requirements, the actual engine horsepower on this class machine will be significantly lower.

Contents

Introduction	1
Safety	2
General Operation	2
Slope Operation	3
Children	3
Service	3
Sound Pressure	4
Sound Power	4
Vibration	4
Safety and Instructional Decals	5
Setup	6
1 Assembling the Handle	6
2 Filling the Engine with Oil	6
Product Overview	7
Specifications	8
Operation	8
Filling the Fuel Tank	8
Checking the Engine Oil Level	9
Adjusting the Cutting Height	9
Starting the Engine	10
Adjusting the Handle Position	10
Stopping the Engine	11
Hauling	11
Operating Tips	12
Maintenance	13
Recommended Maintenance Schedule(s)	13
Preparing for Maintenance	13
Replacing the Air Cleaner	14
Changing the Engine Oil	14
Servicing the Spark Plug	15
Replacing the Nylon Cutting String	16
Cleaning the Machine	16
Storage	16
Preparing the Machine for Storage	16
Troubleshooting	17

Safety

This cutting machine can amputate hands and feet and throw objects. Failure to observe the following safety instructions could result in serious injury or death.

The following safety section is adapted from ANSI B71.4–2012 and EN 14910.

General Operation

- Read the *Operator's Manual* and other training material. If the operator(s) or mechanic(s) cannot read English it is the owners responsibility to explain this material to them.
- Become familiar with the safe operation of the equipment, operator controls, and the safety signs.
- All operators and mechanics should be trained. The owner is responsible for training the users.
- Never let children or untrained people operate or service the equipment. Local regulations may restrict the age of the operator.
- The owner/user can prevent and is responsible for accidents or injuries occurring to themselves, other people, or property.
- Do not put hands or feet near or under the machine.
- Evaluate the terrain to determine what accessories and attachments are needed to properly and safely perform the job. Only use accessories and attachments approved by the manufacturer.
- Clear the area of objects such as rocks, wire, toys, etc., which could be thrown by the cutting line. Stay behind the handle when the engine is running.
- Be sure the area is clear of bystanders before operating. Stop machine if anyone enters the area.
- Always wear substantial, slip-resistant footwear and long pants.
- Wear appropriate clothing including hard hat, safety glasses, and hearing protection. Tie back long hair. Do not wear jewelry.
- Do not pull machine backward unless absolutely necessary. Always look down and behind before and while moving backward.
- slow down and use caution when making turns and crossing roads and sidewalks. Stop cutting element if not mowing.
- Never direct discharged material toward anyone. Avoid discharging material against a wall or obstruction. Material may ricochet back toward the operator. Stop the cutting line when crossing gravel surfaces.
- Check that the operator's presence controls, safety switches, and shields are attached and functioning properly. do not operate unless they are functioning properly.
- Never leave a running machine unattended.
- Stop the engine and wait until the cutting line comes to a complete stop, and remove the spark plug wire before cleaning or unclogging the machine.
- Operate machine only in daylight or good artificial light.

- Do not operate machine while tired, ill, or under the influence of alcohol or drugs.
- Never operate machine in wet grass. Always be sure of your footing; walk; never run.
- Never raise the deck with the engine running.
- If the machine should start to vibrate abnormally, stop the engine and check for the cause immediately. Vibration is generally a warning of trouble.
- Use care when loading or unloading the machine into a trailer or truck.

Slope Operation

Slopes are a major factor related to slip and fall accidents, which can result in severe injury. Operation on all slopes require extra caution. If you feel uneasy on a slope, do not mow it.

- Watch for holes, ruts, bumps, rocks, or other hidden objects. Uneven terrain could cause a slip and fall accident. Tall grass can hide obstacles.
- Do not mow on wet grass or excessively steep slopes. Poor footing could cause a slip and fall accident.
- Do not mow near drop-offs, ditches, or embankments. You could lose your footing or balance.
- When using the machine, always keep both hands on the handlebar.
- When cutting steep slopes from the top of the slope and a longer reach is needed, never tie the HoverPro to a rope; use the extended handlebar kit option.

Children

Tragic accidents can occur if the operator is not alert to the presence of children. Children are often attracted to the machine and the mowing activity. **Never** assume that children will remain where you last saw them.

- Keep children out of the mowing area and under the watchful care of a responsible adult other than the operator.
- Be alert and turn machine off if a child enters the area.
- Never allow children to operate the machine.
- Use extra care when approaching blind corners, shrubs, trees, or other objects that may block your view of a child.

Service

Safe Handling of Gasoline

To avoid personal injury or property damage, use extreme care in handling gasoline. Gasoline is extremely flammable and the vapors are explosive.

- Extinguish all cigarettes, cigars, pipes, and other sources of ignition.
- Use only an approved gasoline container.
- Never remove gas cap or add fuel with the engine running. Allow engine to cool before refueling.
- Never refuel or drain the machine indoors.
- Never store the machine or fuel container where there is an open flame, spark, or pilot light such as on a water heater or on other appliances.
- Never fill containers inside a vehicle or on a truck or trailer bed with a plastic liner. Always place containers on the ground away from your vehicle before filling.
- Remove gas-powered equipment from the truck or trailer and refuel it on the ground. If this is not possible, then refuel such equipment with a portable container, rather than from a gasoline dispenser nozzle.
- Keep the nozzle in contact with the rim of the fuel tank or container opening at all times until fueling is complete. Do not use a nozzle lock-open device.
- If fuel is spilled on clothing, change clothing immediately.
- Never overfill fuel tank. Replace gas cap and tighten securely.

⚠ WARNING

Exhaust contains carbon monoxide, an odorless, deadly poison that can kill you.

Do not run the engine indoors or in an enclosed area.

General Service

- Never operate machine in a closed area.
- Keep all nuts and bolts tight to be sure the equipment is in safe working condition.
- Never tamper with safety devices. Check their proper operation regularly.
- Keep machine free of grass, leaves, or other debris build-up. Clean up oil or fuel spillage and remove any fuel-soaked debris. Allow machine to cool before storing in an enclosed space.
- Never make any adjustments or repairs with the engine running. Disconnect the spark plug wire and ground against engine to prevent unintended starting.

- Do not change the engine governor setting or overspeed the engine.
- Maintain or replace safety and instruction labels, as necessary.
- If gasoline is spilled, do not attempt to start the engine but move the machine away from the area of spillage and avoid creating any source of ignition until the gasoline vapor has dissipated.
- Replace faulty silencers.
- Before using, always visually inspect to see that the cutting line, bolts and cutter assembly are not worn or damaged. Replace worn or damaged cutting lines in sets to preserve balance.
- Stop the cutting line if the machine has to be tilted for transportation when crossing surfaces other than grass, and when transporting the machine to and from the area to be mowed.
- Never pick up or carry a machine while the engine is running.
- Stop the engine and disconnect the spark plug wire, make sure that all moving parts have come to a complete stop:
 - Before clearing blockages.
 - Before checking, cleaning, or working on the machine.
 - After striking a foreign object. Inspect the machine for damage and make repairs before restarting and operating the machine.
 - If the machine starts to vibrate abnormally.
 - Whenever you leave the machine.
 - Before refueling.
- Ensure the engine and fuel tank are empty of fuel before rotating the machine beyond a 25 degree angle.
- Use care when checking the cutting line. Wrap the cutting line or wear gloves, and use caution when servicing them. Only replace the cutting line.
- Keep hands and feet away from moving parts. If possible, do not make adjustments with the engine running.
- Shut off the fuel while storing or transporting the machine. Do not fuel near open flames, and do not drain fuel indoors.
- Park the machine on level ground. Never allow untrained personnel to service the machine.
- Allow the engine to cool before storing in any enclosure.
- Replace worn or damaged parts for safety.
- If the fuel tank has to be drained, this should be done outdoors. The drained fuel should be stored

in a container specifically designed for fuel storage or it should be disposed of carefully.

- Start the engine carefully according to the *Operator's Manual* and with feet away from the cutting elements.
- Do not tilt the trimmer when starting the engine, except if the trimmer has to be tilted for starting. In this case do not tilt it more than absolutely necessary and lift only the part which is away from the operator.
- Examine the trimmer regularly and replace worn or damaged parts for safety. Never replace the cutting unit with metal parts and only use cutting heads and cutting elements which are suitable for use at the operating speed of the trimmer;

Sound Pressure

This machine has a sound pressure level at the operator's ear of 88 dBA, which includes an Uncertainty Value (K) of 2 dBA. The sound pressure level was determined according to the procedures outlined in EN ISO 11201.

Sound Power

This machine has a guaranteed sound power level of 98 dBA, which includes an Uncertainty Value (K) of 2 dBA. The sound power level was determined according to the procedures outlined in EN ISO 3744.

Vibration

Measured vibration level for the left hand = 3.4 m/s².

Measured vibration level for the right hand = 4.4 m/s².

Uncertainty Value (K) = 2 m/s².

The measured values were determined according to the procedures outlined in EN ISO 20643.

Safety and Instructional Decals

Important: Safety and instruction decals are located near areas of potential danger. Replace damaged decals.

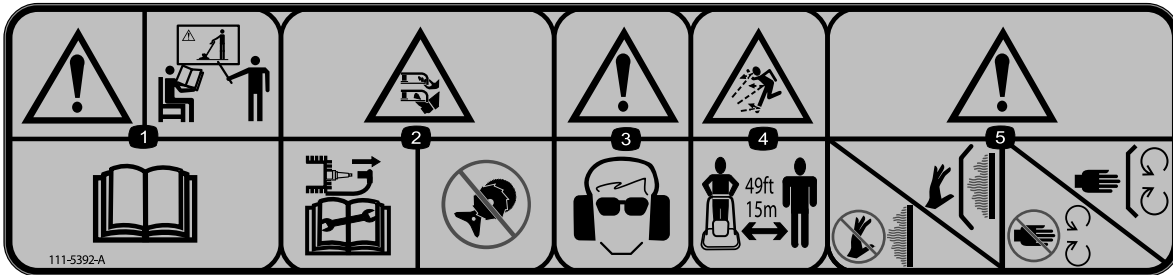

111-5392-A

decal111-5392

111-5392

1. Warning—Receive training on the product; read the *Operator's Manual*.
2. Cutting/dismemberment hazard of hand or foot, Flexiblade line; disconnect the wire from the spark plug before working on the machine; never fit metal cutting parts.
3. Warning—wear eye and hearing protection.
4. Thrown object hazard; keep bystanders at least 15m (49ft) from the machine.
5. Warning—do not touch hot surfaces; keep guards in place; Stay away from moving parts; keep guards in place.



94-8072

94-8072

decal94-8072

1. Warning—cutting/dismemberment hazard of hand or foot, cutting mechanism.



g017410

H295159

g017410

1. Engine stop

For USA and CANADA market

THIS PRODUCT IS INTENDED FOR COMMERCIAL USE ONLY AND DOES NOT COMPLY WITH THE CPSC MANDATORY SAFETY STANDARD 16 C.F.R PART 1205 APPLICABLE TO THIS PRODUCT. SALE OF THIS PRODUCT TO A RESIDENTIAL CUSTOMER WOULD BE IN VIOLATION OF SECTION 19(a)(1) OF THE CONSUMER PRODUCT SAFETY ACT AND COULD EXPOSE THE SELLER TO CIVIL AND CRIMINAL PENALTIES.

111-1210 C

decal111-1210

111-1210

Setup

Note: Determine right and left side of the machine from normal operating position.

1

Assembling the Handle

No Parts Required

Procedure

1. Slide the lower handle into the frame (Figure 3).

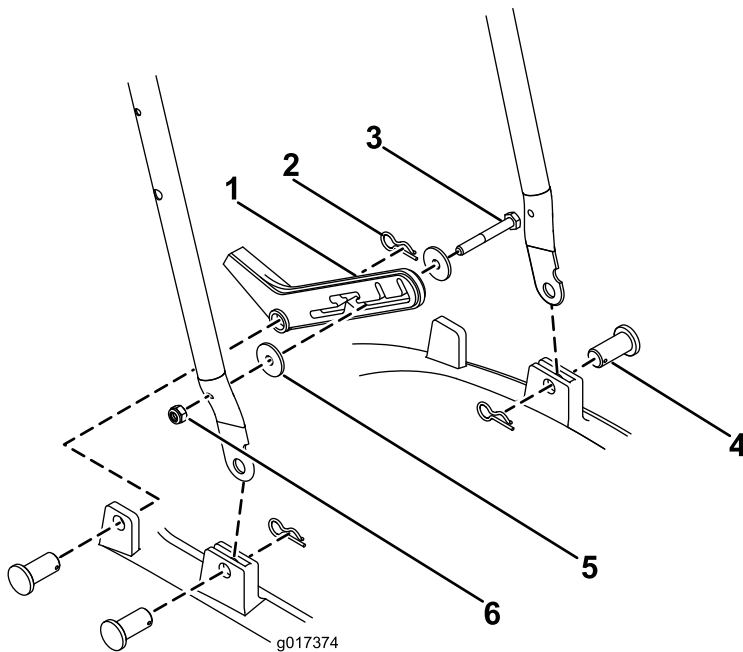

Figure 3

g017374

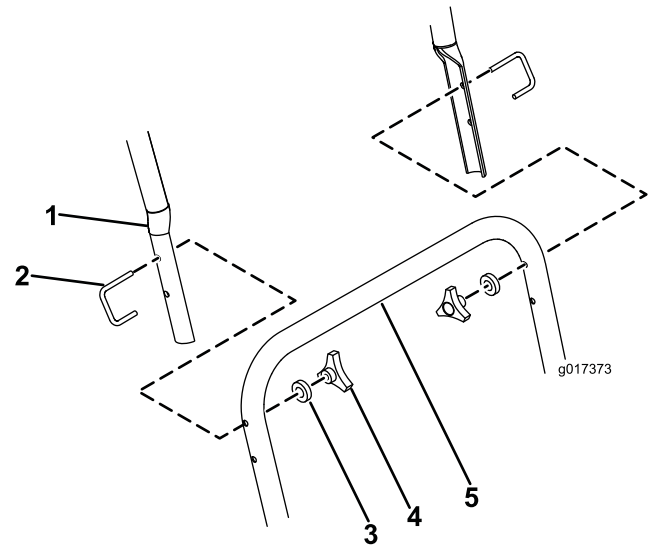

Figure 4

g017373

- | | |
|-----------------|-----------------|
| 1. Upper handle | 4. U bolt |
| 2. Hand wheel | 5. Lower handle |
| 3. Washer | |

2

Filling the Engine with Oil

No Parts Required

Procedure

Important: Your machine does not come with oil in the engine. Before starting the engine, fill the engine with oil.

Max. fill: 0.59 L (20 oz), type: Multigrade Mineral 10W-30 oil with an API service classification of SF, SG, SH, SJ, SL, or higher.

1. Move the machine to a level surface.
2. Remove the dipstick (Figure 5).

2. Secure each side with a retaining pin and a hairpin (Figure 3).
3. Secure the footstop to the right side of the lower handle using an M6 nut, and M6 bolt, and 2 washers (Figure 3).
4. Attach the footstop to the frame with a retaining pin and a hairpin (Figure 3).
5. Connect the upper handle to the lower handle by securing each side with a U bolt, an M6 washer, and a handwheel (Figure 4).

Product Overview

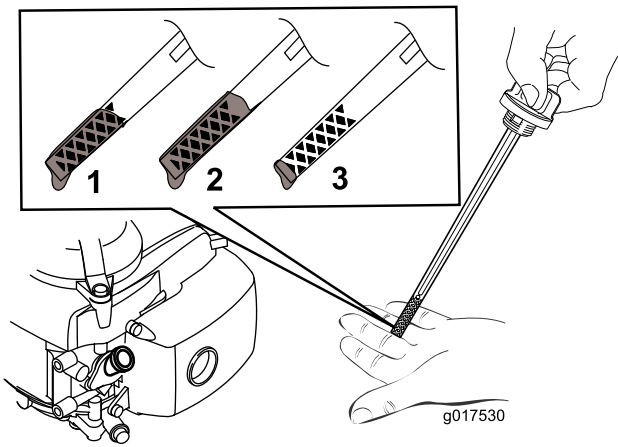

Figure 5

1. The oil level is at its maximum.
2. The oil level is too high—remove oil from the crankcase.
3. The oil level is too low—add oil to the crankcase.

3. **Slowly** pour oil into the oil fill hole, wait 3 minutes, and check the oil level on the dipstick by wiping the dipstick clean and then inserting, **but not screwing in**, the oil fill cap into the hole (Figure 6).

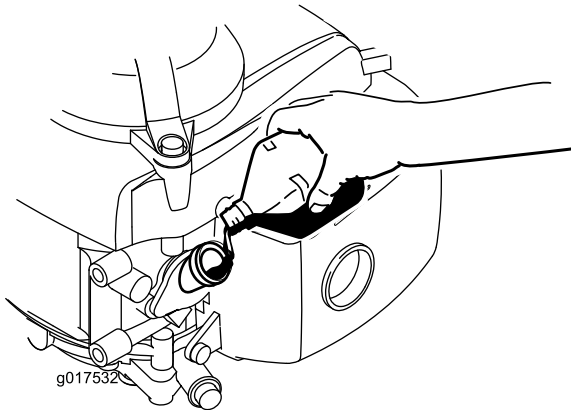

Figure 6

- Note:** Fill the engine crankcase with oil until the dipstick indicates that the engine oil level is correct as shown in Figure 5. If you overfill the engine with oil, remove the excess oil as directed in Changing the Engine Oil.
4. Install the dipstick and hand tighten it securely.

Important: Change the engine oil after the first 5 operating hours; change it yearly thereafter. Refer to Changing the Engine Oil.

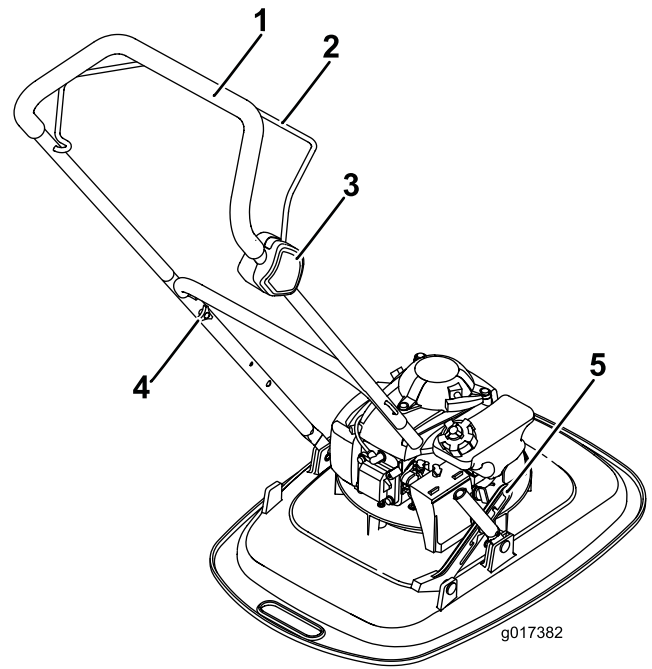

Figure 7

1. Handle
2. Engine-shutoff
3. Switch box
4. Handlebar securing knob
5. Footstop

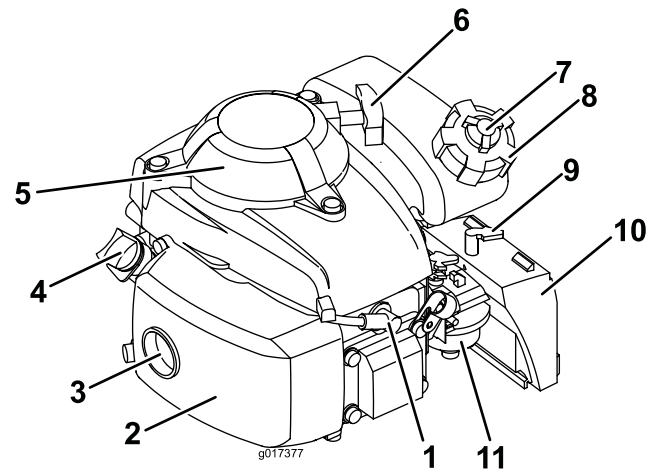

Figure 8

1. Spark plug
2. Exhaust guard
3. Exhaust
4. Dipstick
5. Finger guard
6. Starter grip
7. Fuel-cap-vent knob
8. Fuel cap
9. Choke lever
10. Air cleaner
11. Carburetor

Specifications

Model	Cutting width	Product width
02615	400 mm (15-3/4 inches)	500 mm (19-11/16 inches)

Operation

Filling the Fuel Tank

⚠ DANGER

Gasoline is extremely flammable and explosive. A fire or explosion from gasoline can burn you and others.

- To prevent a static charge from igniting the gasoline, place the container and/or machine directly on the ground before filling, not in a vehicle or on an object.
- Fill the tank outdoors when the engine is cold. Wipe up spills.
- Do not handle gasoline when smoking or around an open flame or sparks.
- Store gasoline in an approved fuel container, out of the reach of children.

Fill the fuel tank with fresh unleaded regular gasoline having an octane rating at or near 87 from a major name-brand service station (Figure 9).

Important: Do not use any fuel that contains more than 10% ethanol. Alternative fuels with high alcohol content can cause hard starting, poor engine performance, and may cause internal engine damage.

Important: To reduce starting problems, add fuel stabilizer to the fuel all season, mixing it with gasoline less than 30 days old.

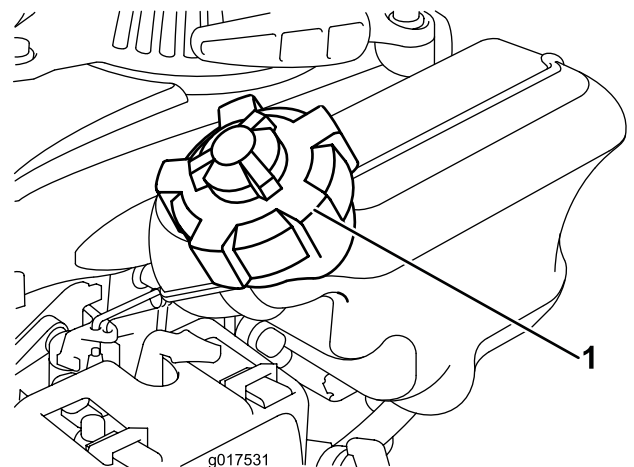

Figure 9

1. Fuel cap

Checking the Engine Oil Level

Service Interval: Before each use or daily

1. Move the machine to a level surface.
2. Remove the dipstick and wipe it with a clean cloth.
3. Insert, **but do not screw in**, the dipstick into the oil fill hole.
4. Remove the dipstick and check it.
5. To determine the proper oil level on the dipstick, refer to [Figure 10](#)).

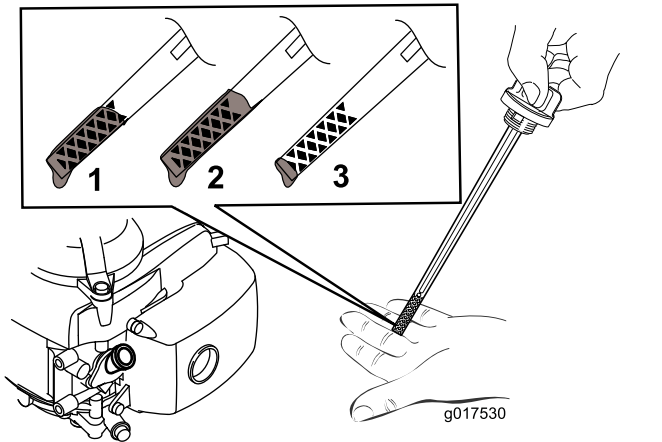

Figure 10

1. The oil level is at its maximum.
 2. The oil level is too high—remove oil from the crankcase.
 3. The oil level is too low—add oil to the crankcase.
-
6. If the oil level is low, **slowly** pour oil into the oil fill hole, wait 3 minutes, and check the oil level on the dipstick by wiping the dipstick clean and then inserting, **but not screwing in**, the oil fill cap into the hole.

Note: Max. fill: 20 oz. (0.59 l), Multigrade Mineral 10W-30 oil with an API service classification of SF, SG, SH, SJ, SL, or higher.

Note: Fill the engine crankcase with oil until the dipstick indicates that the engine oil level is correct as shown in [Figure 10](#). If you overfill the engine with oil, remove the excess oil as directed in [Changing the Engine Oil](#) (page 14).

7. Install the dipstick and hand tighten it securely.

Important: Change the engine oil after the first 5 operating hours; change it yearly thereafter. Refer to [Changing the Engine Oil](#) (page 14).

Adjusting the Cutting Height

⚠ WARNING

Adjusting the cutting height may bring you into contact with the moving cutting unit, causing serious injury.

- Stop the engine and wait for all moving parts to stop.
- Wear gloves while handling the cutting unit.

⚠ CAUTION

If the engine has been running, the muffler will be hot and can severely burn you. Keep away from the hot muffler.

Adjust the cutting height as desired.

1. Turn the fuel switch to the off position.
2. Disconnect the wire from the spark plug.
3. Tilt the machine on its left side.
4. **Wearing protective gloves**, remove the nylon cutting line.
5. Reposition the spacers to the desired height, then reinstall the nylon cutting line.

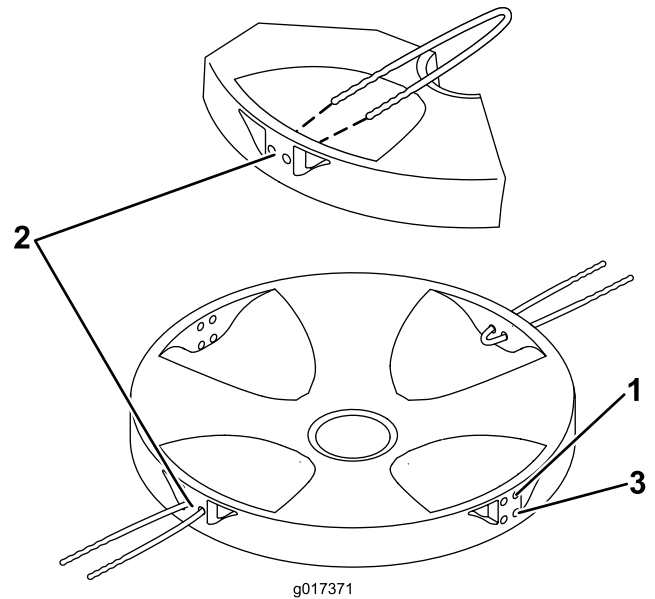

Figure 11

1. High
2. Middle
3. Low

Starting the Engine

1. Open the fuel tank vent by turning the vent knob at least 2 or 3 turns counterclockwise.
2. Turn the fuel valve to the On position (Figure 12).

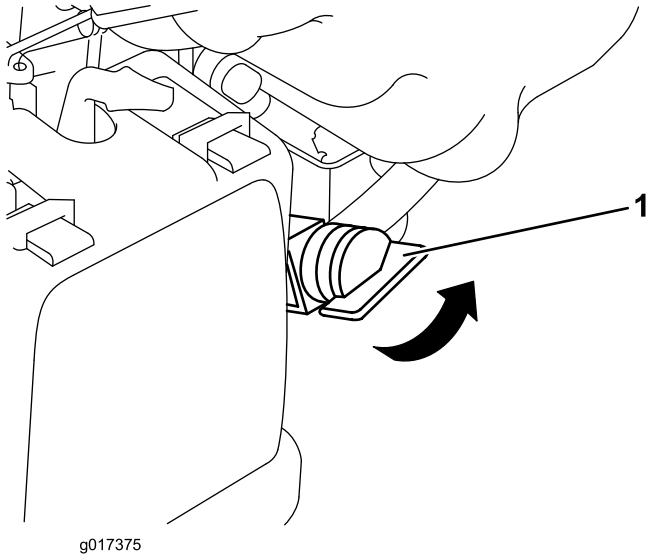

Figure 12

1. Fuel valve

-
3. Place your foot on the deck and tilt the machine towards you (Figure 13).



Figure 13

-
4. Pull the recoil-start handle.

Note: Do not allow the starter grip to snap back against the engine. Return it gently to prevent damage to the starter.

Note: If the machine does not start after several attempts, contact an Authorized Service Dealer.

Adjusting the Handle Position

Refer to Figure 14 for the different handle positions.

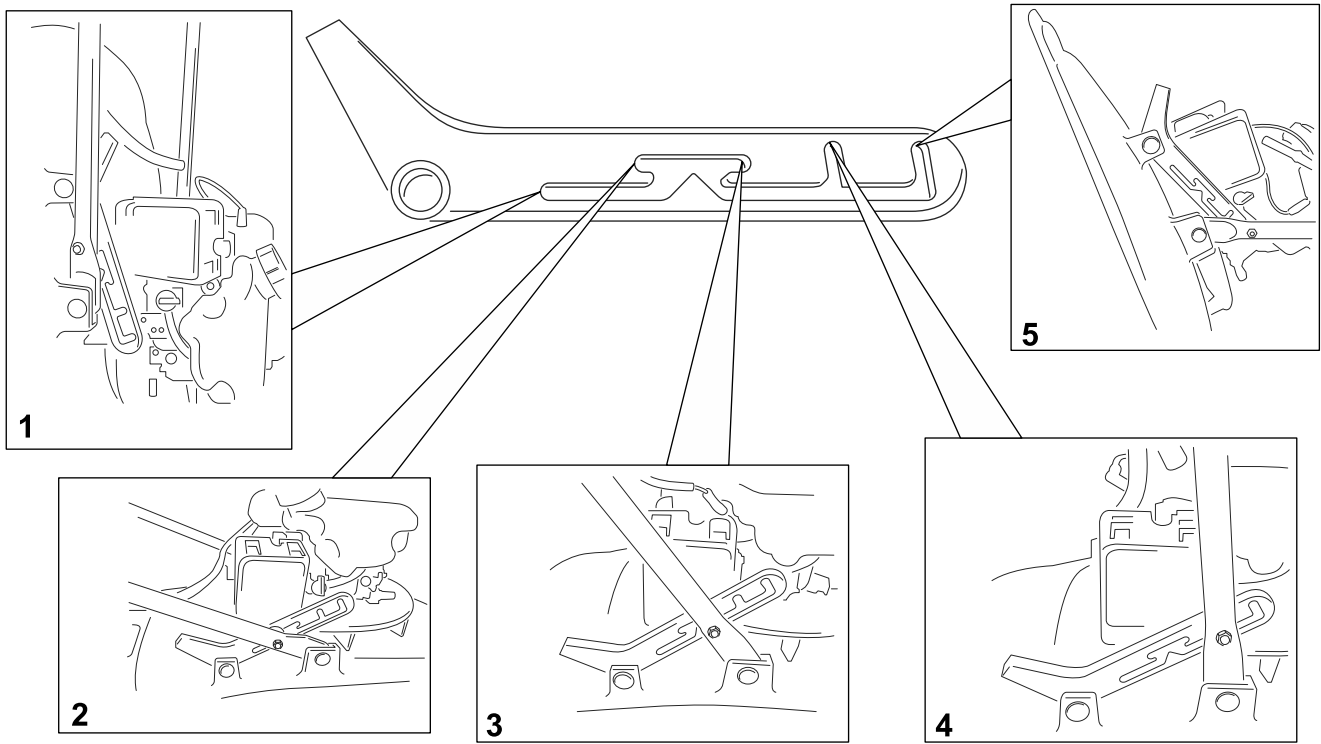

g025627

g025627

Figure 14

1. Hanging storage/transport position
2. Lower working position
3. Upper working position
4. Storage/transport position
5. Service position

Note: For proper storage procedure, refer to [Storage \(page 16\)](#).

Stopping the Engine

Service Interval: Before each use or daily

To stop the engine, release the engine stop handle ([Figure 15](#)).

Important: When you release the engine control bar, both the engine and cutting line should stop within 5 seconds. If they do not stop properly, stop using your machine immediately and contact an Authorized Service Dealer.

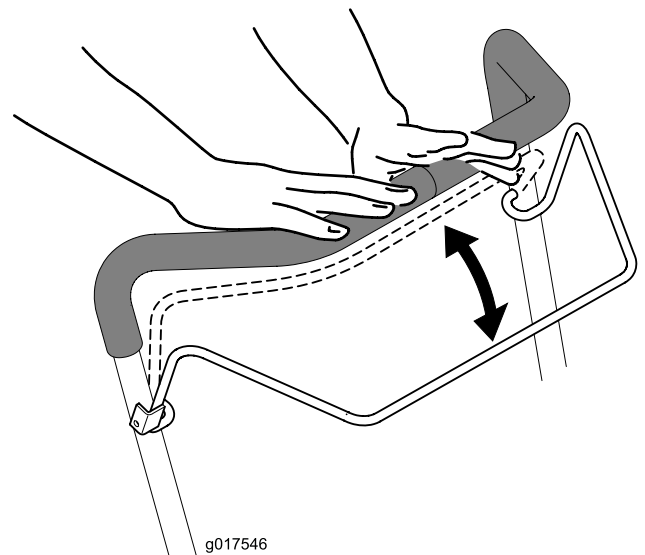

g017546

g017546

Figure 15

Hauling

- Use care when loading or unloading the machine into a trailer or a truck.
- Tie the machine down securely using straps, chains, cable, or ropes. Both the front and the rear

straps should be directed down and outward from the machine.

Operating Tips

General Mowing Tips

⚠ WARNING

Operating the engine on a slope greater than 25° will severely damage the engine because of a lack of lubrication. Potential damage includes stuck valves, scored pistons, or burned crank bearings.

- **Before operating the machine on a slope, complete a site survey to measure the slope where you will operate the machine.**
- **Do not operate the 4-cycle Honda engine on this machine on slopes greater than 25°.**
- Clear the area of sticks, stones, wire, branches, and other debris that the cutting line could hit.
- Avoid striking solid objects with the cutting line. Never deliberately mow over any object.
- If the machine strikes an object or starts to vibrate, immediately stop the engine, disconnect the wire from the spark plug, and examine the machine for damage.
- For best performance, install a new cutting line before the cutting season begins.
- Replace the cutting line when necessary with a Toro replacement cutting line.

Cutting Grass

- Cut only about a third of the grass blade at a time. Do not cut below the 51 mm (2 inch) setting unless the grass is sparse or it is late fall when grass growth begins to slow down. Refer to [Adjusting the Cutting Height \(page 9\)](#).
- Mow only dry grass or leaves. Wet grass and leaves tend to clump on the yard and can cause the machine to plug or the engine to stall.

⚠ WARNING

Wet grass or leaves can cause serious injury if you slip and contact the cutting line. Mow only in dry conditions.

- Alternate the mowing direction. This helps disperse the clippings over the lawn for even fertilization.
- If the finished lawn appearance is unsatisfactory, try one or more of the following:

- Replace the cutting line.
- Walk at a slower pace while mowing.
- Raise the cutting height on your machine.
- Cut the grass more frequently.
- Overlap cutting swaths instead of cutting a full swath with each pass.

Cutting Leaves

- After cutting the lawn, ensure that half of the lawn shows through the cut leaf cover. You may need to make more than one pass over the leaves.
- Slow down your mowing speed if the machine does not cut the leaves finely enough.

Maintenance

Note: Determine the left and right sides of the machine from the normal operating position.

Recommended Maintenance Schedule(s)

Maintenance Service Interval	Maintenance Procedure
After the first 5 hours	<ul style="list-style-type: none"> Change the engine oil.
Before each use or daily	<ul style="list-style-type: none"> Check the engine oil level. Ensure that the engine stops within 5 seconds after releasing the engine stop handle. Clean grass clippings and dirt from the entire machine.
After each use	<ul style="list-style-type: none"> Clean grass clippings and dirt from the entire machine.
Every 100 hours	<ul style="list-style-type: none"> Check the spark plug and replace it if necessary.
Before storage	<ul style="list-style-type: none"> Empty the fuel tank before repairs as directed and before annual storage. Clean the cooling system; remove grass clippings, debris, or dirt from the engine air cooling fins and starter. Clean the system more frequently in dirty or high-chaff conditions.
Yearly	<ul style="list-style-type: none"> Replace the air filter; replace it more frequently in dusty operating conditions. Change the engine oil.

Preparing for Maintenance

- Shut off the engine and wait for all moving parts to stop.
- Disconnect the spark-plug wire from the spark plug (Figure 16) before performing any maintenance procedure.

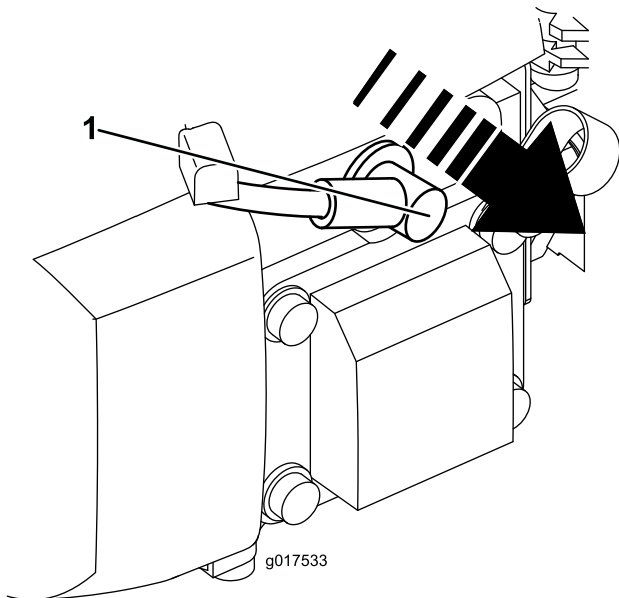

Figure 16

- Spark plug wire

- After performing the maintenance procedure(s), connect the spark-plug wire to the spark plug.

⚠ WARNING

Tipping the machine may cause the fuel to leak. Gasoline is flammable, explosive and can cause personal injury.

Run the engine dry or remove the gasoline with a hand pump; never siphon.

Important: Always tip the machine onto its side with the dipstick down.

Replacing the Air Cleaner

Service Interval: Yearly

1. Press down on the latch tabs on top of the air cleaner cover (Figure 17).

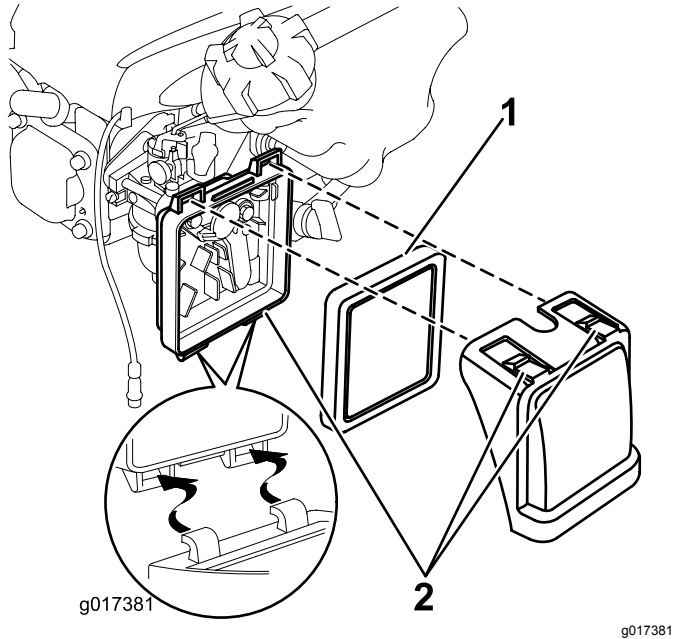

Figure 17

1. Filter
2. Latch tabs

2. Open the cover (Figure 17).
 3. Remove the filter (Figure 17).
 4. Inspect the air filter.
 - A. If the filter is damaged or is wet with oil or fuel, replace it.
 - B. If the filter is dirty, tap it on a hard surface several times or blow compressed air less than 207 kPa (30 psi) through the side of the filter that faces the engine.
- Note:** Do not brush the dirt off the filter; brushing forces dirt into the fibers.
5. Remove dirt from the air cleaner body and cover using a moist rag. **Do not wipe dirt into the air duct.**
 6. Insert the filter into the air cleaner (Figure 17).
 7. Install the cover (Figure 17).

Changing the Engine Oil

Service Interval: After the first 5 hours

Yearly

1. Ensure that the fuel tank contains little or no fuel so that fuel does not leak out when you tip the machine onto its side.
2. Run the engine a few minutes before changing the oil to warm it.

Note: Warm oil flows better and carries more contaminants.

3. Disconnect the wire from the spark plug. Refer to Preparing for Maintenance.
4. Remove the dipstick.
5. Tip the machine onto its side, with the dipstick down, to drain the used oil out through the oil fill tube.
6. Return the machine to the operating position.
7. **Slowly** pour oil into the oil fill hole, wait 3 minutes, and check the oil level on the dipstick by wiping the dipstick clean and then inserting, **but not screwing in**, the oil fill cap into the hole.

Note: Max. fill: 0.59 L (20 oz), type: Multigrade Mineral 10W-30 oil with an API service classification of SF, SG, SH, SJ, SL, or higher.

Note: Fill the engine crankcase with oil until the dipstick indicates that the engine oil level is correct as shown in (Figure 18). If you overfill the engine with oil, remove the excess oil as directed in 5.

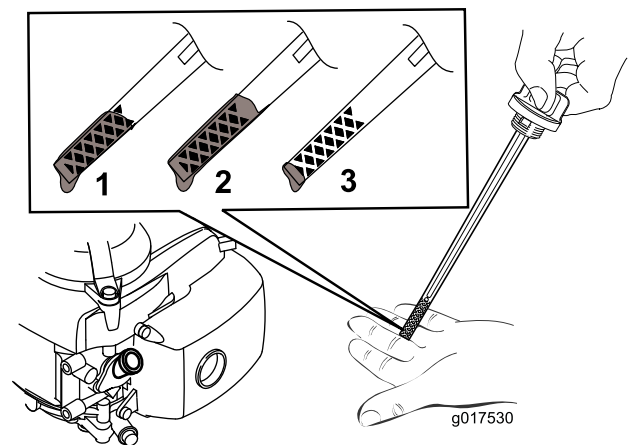

Figure 18

1. The oil level is at its maximum.
2. The oil level is too high—remove oil from the crankcase.
3. The oil level is too low—add oil to the crankcase.

8. Install the dipstick and hand tighten it securely.

- Dispose of the used oil properly at a local recycling center.

Servicing the Spark Plug

Service Interval: Every 100 hours

Use a **Champion RN9YC** spark plug or equivalent.

- Stop the engine and wait for all moving parts to stop.
- Disconnect the wire from the spark plug.
- Clean around the spark plug.
- Remove the spark plug from the cylinder head.

Important: Replace a cracked, fouled, or dirty spark plug. Do not clean the electrodes because grit entering the cylinder can damage the engine.

- Set the gap on the plug to 0.76 mm (0.030 inch) as shown in [Figure 19](#).

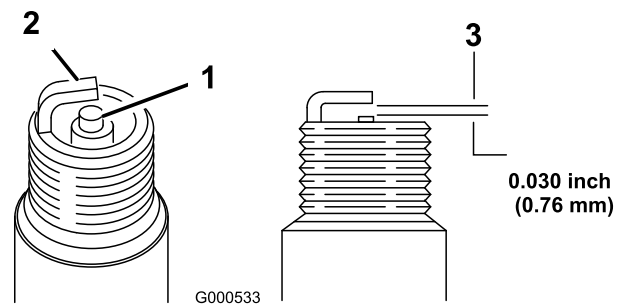

Figure 19

- Center electrode insulator
- Side electrode
- Air gap (not to scale)

-
- Install the spark plug and the gasket seal.
 - Torque the plug to 20 N-m (15 ft-lb).
 - Connect the wire to the spark plug.

Replacing the Nylon Cutting String

1. Turn the fuel tap to the OFF position and close the vent knob.
2. Disconnect the wire from the spark plug.
3. Turn the machine on its left side, with the carburetor facing upwards.
4. **Wearing protective gloves**, remove the nylon cutting line.
5. Place one length of nylon cutting line into the desired cutting height setting. Ensure that a second length is placed in the corresponding cutting height on the opposite side of the cutting disc.

Note: If using a spare reel, cut the line to a length of 200 mm (7-7/8 inches).

Cleaning the Machine

Service Interval: Before each use or daily
After each use

⚠ WARNING

The machine may dislodge material from under the machine housing.

- **Wear eye protection.**
 - **Stay in the operating position (behind the handle).**
 - **Do not allow bystanders in the area.**
1. Tip the machine on its side.
 2. Use a brush or compressed air to remove grass and debris from the exhaust guard, the top cowl, and the surrounding deck areas.

Storage

Store the machine in a cool, clean, dry place.

Preparing the Machine for Storage

⚠ WARNING

Gasoline vapors can explode.

- **Do not store gasoline more than 30 days.**
 - **Do not store the machine in an enclosure near an open flame.**
 - **Allow the engine to cool before storing it.**
1. On the last refueling of the year, add fuel stabilizer to the fuel as directed by the engine manufacturer.
 2. Run the machine until the engine stops from running out of fuel.
 3. Prime the engine and start it again.
 4. Allow the engine to run until it stops. When you can no longer start the engine, it is sufficiently dry.
 5. If you are storing the machine hanging on a wall, switch the fuel tap off and close the vent of the fuel cap.
 6. Disconnect the wire from the spark plug.
 7. Remove the spark plug, add 30 ml (1 oz.) of oil through the spark plug hole, and pull the starter rope **slowly** several times to distribute oil throughout the cylinder to prevent cylinder corrosion during the off-season.
 8. Install the spark plug and tighten it with a torque wrench to 20 N-m (15 ft-lb).
 9. Tighten all nuts, bolts, and screws.

Troubleshooting

Problem	Possible Cause	Corrective Action
The engine does not start.	<ol style="list-style-type: none"> 1. The wire is not connected to the spark plug. 2. The fuel cap vent hole is plugged. 3. The spark plug is pitted, fouled, or the gap is incorrect. 4. The fuel tank is empty or the fuel system contains stale fuel. 	<ol style="list-style-type: none"> 1. Connect the wire to the spark plug. 2. Clean the fuel cap vent hole or replace the fuel cap. 3. Check the spark plug and adjust the gap if necessary. Replace the spark plug if it is pitted, fouled, or cracked. 4. Drain and/or fill the fuel tank with fresh gasoline. If the problem persists, contact an Authorized Service Dealer.
The engine starts hard or loses power.	<ol style="list-style-type: none"> 1. The fuel cap vent hole is plugged. 2. The air filter element is dirty and is restricting the air flow. 3. The underside of the machine housing contains clippings and debris. 4. The spark plug is pitted, fouled, or the gap is incorrect. 5. The engine oil level is too low, too high, or excessively dirty. 6. The fuel tank contains stale fuel. 	<ol style="list-style-type: none"> 1. Clean the fuel cap vent hole or replace the fuel cap. 2. Clean the air filter and/or replace the air filter. 3. Clean under the machine housing. 4. Check the spark plug and adjust the gap if necessary. Replace the spark plug if it is pitted, fouled, or cracked. 5. Check the engine oil. Change the oil if it is dirty; add or drain the oil to adjust the oil level to the Full mark on the dipstick. 6. Drain and fill the fuel tank with fresh gasoline.
The engine runs rough.	<ol style="list-style-type: none"> 1. The wire is not connected to the spark plug. 2. The spark plug is pitted, fouled, or the gap is incorrect. 3. The air filter element is dirty and is restricting the air flow. 	<ol style="list-style-type: none"> 1. Connect the wire to the spark plug. 2. Check the spark plug and adjust the gap if necessary. Replace the spark plug if it is pitted, fouled, or cracked. 3. Clean the air filter and/or replace the air filter.
The machine or engine vibrates excessively.	<ol style="list-style-type: none"> 1. The underside of the machine housing contains clippings and debris. 2. The engine mounting bolts are loose. 3. The cutting disc bolt is loose. 	<ol style="list-style-type: none"> 1. Clean under the machine housing. 2. Tighten the engine mounting bolts. 3. Tighten the cutting disc bolt.
There is an uneven cutting pattern.	<ol style="list-style-type: none"> 1. You are mowing in the same pattern repeatedly. 2. The underside of the machine housing contains clippings and debris. 	<ol style="list-style-type: none"> 1. Change the mowing pattern. 2. Clean under the machine housing.

Notes:

International Distributor List

Distributor:	Country:	Phone Number:	Distributor:	Country:	Phone Number:
Agrolanc Kft	Hungary	36 27 539 640	Maquiver S.A.	Colombia	57 1 236 4079
Balama Prima Engineering Equip.	Hong Kong	852 2155 2163	Maruyama Mfg. Co. Inc.	Japan	81 3 3252 2285
B-Ray Corporation	Korea	82 32 551 2076	Mountfield a.s.	Czech Republic	420 255 704 220
Casco Sales Company	Puerto Rico	787 788 8383	Mountfield a.s.	Slovakia	420 255 704 220
Ceres S.A.	Costa Rica	506 239 1138	Munditol S.A.	Argentina	54 11 4 821 9999
CSSC Turf Equipment (pvt) Ltd.	Sri Lanka	94 11 2746100	Norma Garden	Russia	7 495 411 61 20
Cyril Johnston & Co.	Northern Ireland	44 2890 813 121	Oslinger Turf Equipment SA	Ecuador	593 4 239 6970
Cyril Johnston & Co.	Republic of Ireland	44 2890 813 121	Oy Hako Ground and Garden Ab	Finland	358 987 00733
Equiver	Mexico	52 55 539 95444	Parkland Products Ltd.	New Zealand	64 3 34 93760
Femco S.A.	Guatemala	502 442 3277	Perfetto	Poland	48 61 8 208 416
ForGarder OU	Estonia	372 384 6060	Pratoverde SRL.	Italy	39 049 9128 128
G.Y.K. Company Ltd.	Japan	81 726 325 861	Prochaska & Cie	Austria	43 1 278 5100
Geomechaniki of Athens	Greece	30 10 935 0054	RT Cohen 2004 Ltd.	Israel	972 986 17979
Golf international Turizm	Turkey	90 216 336 5993	Riversa	Spain	34 9 52 83 7500
Guandong Golden Star	China	86 20 876 51338	Lely Turfcare	Denmark	45 66 109 200
Hako Ground and Garden	Sweden	46 35 10 0000	Solvart S.A.S.	France	33 1 30 81 77 00
Hako Ground and Garden	Norway	47 22 90 7760	Spypros Stavrinides Limited	Cyprus	357 22 434131
Hayter Limited (U.K.)	United Kingdom	44 1279 723 444	Surge Systems India Limited	India	91 1 292299901
Hydroturf Int. Co Dubai	United Arab Emirates	97 14 347 9479	T-Markt Logistics Ltd.	Hungary	36 26 525 500
Hydroturf Egypt LLC	Egypt	202 519 4308	Toro Australia	Australia	61 3 9580 7355
Irrimac	Portugal	351 21 238 8260	Toro Europe NV	Belgium	32 14 562 960
Irrigation Products Int'l Pvt Ltd.	India	0091 44 2449 4387	Valtech	Morocco	212 5 3766 3636
Jean Heybroek b.v.	Netherlands	31 30 639 4611	Victus Emak	Poland	48 61 823 8369

European Privacy Notice

The Information Toro Collects

Toro Warranty Company (Toro) respects your privacy. In order to process your warranty claim and contact you in the event of a product recall, we ask you to share certain personal information with us, either directly or through your local Toro company or dealer.

The Toro warranty system is hosted on servers located within the United States where privacy law may not provide the same protection as applies in your country.

BY SHARING YOUR PERSONAL INFORMATION WITH US, YOU ARE CONSENTING TO THE PROCESSING OF YOUR PERSONAL INFORMATION AS DESCRIBED IN THIS PRIVACY NOTICE.

The Way Toro Uses Information

Toro may use your personal information to process warranty claims, to contact you in the event of a product recall and for any other purpose which we tell you about. Toro may share your information with Toro's affiliates, dealers or other business partners in connection with any of these activities. We will not sell your personal information to any other company. We reserve the right to disclose personal information in order to comply with applicable laws and with requests by the appropriate authorities, to operate our systems properly or for our own protection or that of other users.

Retention of your Personal Information

We will keep your personal information as long as we need it for the purposes for which it was originally collected or for other legitimate purposes (such as regulatory compliance), or as required by applicable law.

Toro's Commitment to Security of Your Personal Information

We take reasonable precautions in order to protect the security of your personal information. We also take steps to maintain the accuracy and current status of personal information.

Access and Correction of your Personal Information

If you would like to review or correct your personal information, please contact us by email at legal@toro.com.

Australian Consumer Law

Australian customers will find details relating to the Australian Consumer Law either inside the box or at your local Toro Dealer.



The Toro Total Coverage Guarantee

A Limited Warranty

Conditions and Products Covered

The Toro® Company and its affiliate, Toro Warranty Company, pursuant to an agreement between them, jointly warrant your Toro Commercial product ("Product") to be free from defects in materials or workmanship for two years or 1500 operational hours*, whichever occurs first. This warranty is applicable to all products with the exception of Aerators (refer to separate warranty statements for these products). Where a warrantable condition exists, we will repair the Product at no cost to you including diagnostics, labor, parts, and transportation. This warranty begins on the date the Product is delivered to the original retail purchaser.

* Product equipped with an hour meter.

Instructions for Obtaining Warranty Service

You are responsible for notifying the Commercial Products Distributor or Authorized Commercial Products Dealer from whom you purchased the Product as soon as you believe a warrantable condition exists. If you need help locating a Commercial Products Distributor or Authorized Dealer, or if you have questions regarding your warranty rights or responsibilities, you may contact us at:

Commercial Products Service Department
Toro Warranty Company
8111 Lyndale Avenue South
Bloomington, MN 55420-1196
E-mail: commercial.warranty@toro.com

Owner Responsibilities

As the Product owner, you are responsible for required maintenance and adjustments stated in your Operator's Manual. Failure to perform required maintenance and adjustments can be grounds for disallowing a warranty claim.

Items and Conditions Not Covered

Not all product failures or malfunctions that occur during the warranty period are defects in materials or workmanship. This warranty does not cover the following:

- Product failures which result from the use of non-Toro replacement parts, or from installation and use of add-on, or modified non-Toro branded accessories and products. A separate warranty may be provided by the manufacturer of these items.
- Product failures which result from failure to perform recommended maintenance and/or adjustments. Failure to properly maintain your Toro product per the Recommended Maintenance listed in the *Operator's Manual* can result in claims for warranty being denied.
- Product failures which result from operating the Product in an abusive, negligent or reckless manner.
- Parts subject to consumption through use unless found to be defective. Examples of parts which are consumed, or used up, during normal Product operation include, but are not limited to, brakes pads and linings, clutch linings, blades, reels, bed knives, tines, castor wheels, tires, filters, belts, and certain sprayer components such as diaphragms, nozzles, and check valves, etc.
- Failures caused by outside influence. Items considered to be outside influence include, but are not limited to, weather, storage practices,

contamination, use of unapproved coolants, lubricants, additives, fertilizers, water, or chemicals, etc.

- Normal noise, vibration, wear and tear, and deterioration.
- Normal "wear and tear" includes, but is not limited to, damage to seats due to wear or abrasion, worn painted surfaces, scratched decals or windows, etc.

Parts

Parts scheduled for replacement as required maintenance are warranted for the period of time up to the scheduled replacement time for that part. Parts replaced under this warranty are covered for the duration of the original product warranty and become the property of Toro. Toro will make the final decision whether to repair any existing part or assembly or replace it. Toro may use remanufactured parts for warranty repairs.

Note Regarding Deep Cycle Battery Warranty:

Deep cycle batteries have a specified total number of kilowatt-hours they can deliver during their lifetime. Operating, recharging, and maintenance techniques can extend or reduce total battery life. As the batteries in this product are consumed, the amount of useful work between charging intervals will slowly decrease until the battery is completely worn out. Replacement of worn out batteries, due to normal consumption, is the responsibility of the product owner. Battery replacement may be required during the normal product warranty period at owner's expense.

Maintenance is at Owner's Expense

Engine tune-up, lubrication cleaning and polishing, replacement of Items and Conditions Not Covered filters, coolant, and completing Recommended Maintenance are some of the normal services Toro products require that are at the owner's expense.

General Conditions

Repair by an Authorized Toro Distributor or Dealer is your sole remedy under this warranty.

Neither The Toro Company nor Toro Warranty Company is liable for indirect, incidental or consequential damages in connection with the use of the Toro Products covered by this warranty, including any cost or expense of providing substitute equipment or service during reasonable periods of malfunction or non-use pending completion of repairs under this warranty. Except for the Emissions warranty referenced below, if applicable, there is no other express warranty.

All implied warranties of merchantability and fitness for use are limited to the duration of this express warranty. Some states do not allow exclusions of incidental or consequential damages, or limitations on how long an implied warranty lasts, so the above exclusions and limitations may not apply to you.

This warranty gives you specific legal rights, and you may also have other rights which vary from state to state.

Countries Other than the United States or Canada

Customers should contact their Toro Distributor (Dealer) to obtain guarantee policies for your country, province, or state. If for any reason you are dissatisfied with your Distributor's service or have difficulty obtaining guarantee information, contact the Toro importer. If all other remedies fail, you may contact us at Toro Warranty Company.