



Count on it.

Operator's Manual

**Groundsmaster® 4100 and 4110
Rotary Mower**

Model No. 30606—Serial No. 313000001 and Up

Model No. 30606A—Serial No. 314000001 and Up

Model No. 30608—Serial No. 313000001 and Up

Model No. 30608A—Serial No. 314000001 and Up



This product complies with all relevant European directives, for details please see the separate product specific Declaration of Conformity (DOC) sheet.

▲ WARNING

**CALIFORNIA
Proposition 65 Warning**

This product contains a chemical or chemicals known to the State of California to cause cancer, birth defects, or reproductive harm.

Diesel engine exhaust and some of its constituents are known to the State of California to cause cancer, birth defects, and other reproductive harm.

Because in some areas there are local, state, or federal regulations requiring that a spark arrester be used on the engine of this machine, a spark arrester is incorporated with the muffler assembly.

Genuine Toro spark arresters are approved by the USDA Forestry Service.

Important: This engine is equipped with a spark arrester muffler. It is a violation of California Public Resource Code Section 4442 to use or operate the engine on any forest-covered, brush-covered, or grass-covered land without a spark arrester muffler maintained in working order, or the engine constricted, equipped, and maintained for the prevention of fire. Other states or federal areas may have similar laws.

Introduction

This machine is a ride-on, rotary-blade lawnmower intended to be used by professional, hired operators in commercial applications. It is primarily designed for cutting grass on well-maintained lawns in parks, sports fields, and on commercial grounds. It is not designed for cutting brush, mowing grass and other growth alongside highways, or for agricultural uses.

Read this information carefully to learn how to operate and maintain your product properly and to avoid injury and product damage. You are responsible for operating the product properly and safely.

You may contact Toro directly at www.Toro.com for product and accessory information, help finding a dealer, or to register your product.

Whenever you need service, genuine Toro parts, or additional information, contact an Authorized Service

Dealer or Toro Customer Service and have the model and serial numbers of your product ready. **Figure 1** identifies the location of the model and serial numbers on the product. Write the numbers in the space provided.

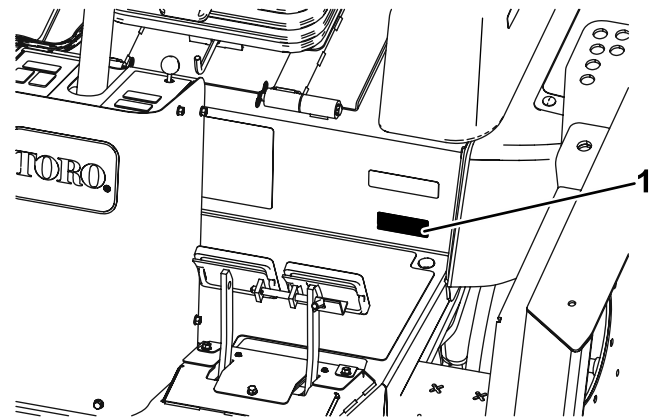

g020447

g020447

Figure 1

1. Model and serial number location

| |
|------------------|
| Model No. _____ |
| Serial No. _____ |

This manual identifies potential hazards and has safety messages identified by the safety alert symbol (**Figure 2**), which signals a hazard that may cause serious injury or death if you do not follow the recommended precautions.



Figure 2

g000502

1. Safety alert symbol

This manual uses 2 other words to highlight information. **Important** calls attention to special mechanical information and **Note** emphasizes general information worthy of special attention.

Contents

| | | | |
|---|----|--|----|
| Safety | 4 | Changing the Planetary Gear Drive Oil | 59 |
| Safe Operating Practices | 4 | Changing the Rear Axle Lubricant | 60 |
| Toro Mower Safety | 6 | Checking the Rear Wheel Toe-In | 60 |
| Sound Power Level | 7 | Changing the Front Tires | 60 |
| Sound Pressure Level | 7 | Cooling System Maintenance | 61 |
| Vibration Level | 7 | Servicing the Engine Cooling System | 61 |
| Engine Emission Certification | 7 | Brake Maintenance | 61 |
| Safety and Instructional Decals | 8 | Adjusting the Service Brakes | 61 |
| Setup | 16 | Belt Maintenance | 62 |
| 1 Greasing the Machine | 16 | Servicing the Alternator Belt | 62 |
| 2 Replacing the Warning Decal | 16 | Servicing the Compressor Belt..... | 62 |
| Product Overview | 17 | Re-tensioning the Blade Drive Belts..... | 63 |
| Controls | 17 | Replacing the Blade Drive Belt..... | 63 |
| Specifications | 24 | Hydraulic System Maintenance | 64 |
| Attachments/Accessories | 24 | Changing the Hydraulic Fluid | 64 |
| Operation | 25 | Replacing the Hydraulic Filters | 65 |
| Before Operating | 25 | Checking the Hydraulic Lines and Hoses..... | 65 |
| Adjusting the Mirrors..... | 33 | Adjusting the Counterbalance Pressure..... | 66 |
| Aiming the Headlights..... | 34 | Mower Maintenance..... | 66 |
| Starting and Stopping the Engine..... | 34 | Pivoting (Tilting) the Front Cutting Unit Upright..... | 66 |
| Cutting Grass with the Machine | 34 | Pivoting the Front Cutting Unit Down..... | 67 |
| Diesel Particulate Filter Regeneration..... | 35 | Adjusting the Cutting Unit Pitch..... | 67 |
| Smart Power..... | 43 | Servicing the Castor Arm Bushings..... | 68 |
| Reversing Fan Operation..... | 43 | Servicing the Castor Wheels and Bearings..... | 68 |
| Auto Idle | 43 | Replacing the Cutting Unit Hinge Covers | 69 |
| Cruise Control | 43 | Blade Maintenance | 70 |
| Engine Speed Switch..... | 43 | Checking for a Bent Blade | 70 |
| Mow Speed | 43 | Removing and Installing the Cutter Blade(s) | 70 |
| Transport Speed..... | 43 | Inspecting and Sharpening the Cutter Blade(s) | 70 |
| Checking the Interlock Switches | 44 | Correcting Cutting Unit Mismatch | 71 |
| Using the Rollover Protection System (ROPS) | 44 | Cab Maintenance | 72 |
| Pushing or Towing the Machine | 45 | Cleaning the Cab Air Filters | 72 |
| Jacking Points | 45 | Cleaning the Air Conditioning Coil | 73 |
| Tie Downs..... | 45 | Cleaning the A/C Condenser Screen | 73 |
| Operating Characteristics | 45 | Storage | 74 |
| Operating Tips | 46 | Preparing for Seasonal Storage..... | 74 |
| Maintenance | 48 | Schematics | 75 |
| Recommended Maintenance Schedule(s) | 48 | | |
| Service Interval Chart | 49 | | |
| Lubrication | 50 | | |
| Greasing the Bearings and Bushings..... | 50 | | |
| Engine Maintenance | 52 | | |
| Air Cleaner Maintenance | 52 | | |
| Servicing the Engine Oil..... | 53 | | |
| Servicing the Diesel-Oxidation Catalyst (DOC) and the Soot Filter | 54 | | |
| Fuel System Maintenance | 55 | | |
| Servicing the Fuel System | 55 | | |
| Servicing the Water Separator | 55 | | |
| Servicing the Engine Fuel Filter | 56 | | |
| Electrical System Maintenance | 57 | | |
| Battery Care | 57 | | |
| Fuses..... | 58 | | |
| Drive System Maintenance | 59 | | |
| Adjusting the Traction Pedal Angle | 59 | | |

Safety

This machine meets or exceeds CEN standard EN 836:1997, ISO standard 5395:1990, and ANSI B71.4-2012 specifications in effect at the time of production.

Improper use or maintenance by the operator or owner can result in injury. To reduce the potential for injury, comply with these safety instructions and always pay attention to the safety alert symbol, which means Caution, Warning, or Danger—personal safety instruction. Failure to comply with the instruction may result in personal injury or death.

Safe Operating Practices

The following instructions are from the CEN standard EN 836:1997, ISO standard 5395:1990, and ANSI standard B71.4-2012.

Training

- Read the *Operator's Manual* and other training material carefully. Be familiar with the controls, safety signs, and the proper use of the equipment.
- Never allow children or people unfamiliar with these instructions to use the mower. Local regulations may restrict the age of the operator.
- Never mow while people, especially children, or pets are nearby.
- Keep in mind that the operator or user is responsible for accidents or hazards occurring to himself or herself, other people, or property.
- Do not carry passengers.
- All drivers and mechanics should seek and obtain professional and practical instruction. The owner is responsible for training the users. Such instruction should emphasize:
 - the need for care and concentration when working with ride-on machines;
 - control of a ride-on machine sliding on a slope will not be regained by the application of the brake. The main reasons for loss of control are:
 - ◇ insufficient wheel grip;
 - ◇ being driven too fast;
 - ◇ inadequate braking;
 - ◇ the type of machine is unsuitable for its task;
 - ◇ lack of awareness of the effect of ground conditions, especially slopes;
 - ◇ incorrect hitching and load distribution.

Preparation

- While mowing, always wear substantial footwear, long trousers, hard hat, safety glasses, and hearing protection. Long hair, loose clothing or jewelry may get tangled in moving parts. Do not operate the equipment when barefoot or wearing open sandals.
- Thoroughly inspect the area where the equipment is to be used and remove all objects which may be thrown by the machine.
- **Warning**—fuel is highly flammable. Take the following precautions:
 - Store fuel in containers specifically designed for this purpose.
 - Refuel outdoors only and do not smoke while refuelling.
 - Add fuel before starting the engine. Never remove the cap of the fuel tank or add fuel while the engine is running or when the engine is hot.
 - If fuel is spilled, do not attempt to start the engine but move the machine away from the area of spillage and avoid creating any source of ignition until fuel vapors have dissipated.
 - Replace all fuel tank and container caps securely.
- Replace faulty silencers/mufflers.
- Before using, always visually inspect to see that the blades, blade bolts, and cutting assembly are not worn or damaged. Replace worn or damaged blades and bolts in sets to preserve balance.
- On multi-bladed machines, take care as rotating one blade can cause other blades to rotate.
- Evaluate the terrain to determine what accessories and attachments are needed to properly and safely perform the job. Only use accessories and attachments approved by the manufacturer.
- Check that operators presence controls, safety switches, and shields are attached and functioning properly. Do not operate unless they are functioning properly.

Operation

- Do not operate the engine in a confined space where dangerous carbon monoxide fumes can collect.
- Mow only in daylight or in good artificial light.
- Before attempting to start the engine, disengage all blade attachment clutches and engage the parking brake. Only start the engine from the operator's position. Always use the seat belt and ROPS together.

- Remember there is no such thing as a safe slope. Travel on grass slopes requires particular care. To guard against overturning:
 - Do not stop or start suddenly when going up or downhill.
 - The machine speed should be kept low on slopes and during tight turns.
 - Stay alert for humps and hollows and other hidden hazards.
 - Never mow across the face of the slope, unless the machine is designed for that purpose.
- Stay alert for holes in the terrain and other hidden hazards.
- Use care when using heavy equipment.
 - Do not turn sharply. Use care when reversing.
 - Use counterweight(s) or wheel weights when suggested in the *Operator's Manual*.
- Watch out for traffic when crossing or near roadways.
- Stop the blades from rotating before crossing surfaces other than grass.
- When using any attachments, never direct discharge of material toward bystanders nor allow anyone near the machine while in operation.
- Never operate the machine with damaged guards, shields, or without safety protective devices in place. Be sure all interlocks are attached, adjusted properly, and functioning properly.
- Before leaving the operators position:
 - Stop on level ground.
 - Disengage the power take-off.
 - Set the parking brake.
 - Stop the engine and remove the key.
- Disengage drive to attachments, stop the engine, and remove the ignition key:
 - before clearing blockages;
 - before checking, cleaning, or working on the machine;
 - after striking a foreign object. Inspect the machine for damage and make repairs before restarting and operating the equipment. Torque all the spindle pulley nuts to 176 to 203 N-m (130 to 150 ft.-lbs.);
 - if the machine starts to vibrate abnormally (check immediately).
- Disengage drive to attachments when transporting or not in use.
- Stop the engine and disengage drive to attachment:
 - before refuelling;
 - before making height adjustment.
- Reduce the throttle to low idle before stopping engine.
- Keep hands and feet away from the cutting units.
- Look behind before backing up to be sure of a clear path.
- Slow down and use caution when making turns and crossing roads and sidewalks.
- Do not operate the mower under the influence of alcohol or drugs.
- Lightning can cause severe injury or death. If lightning is seen or thunder is heard in the area, do not operate the machine; seek shelter.
- Use care when loading or unloading the machine into a trailer or truck.
- The operator shall turn on flashing warning lights, if provided, whenever traveling on a public road, except where such use is prohibited by law.

Maintenance and Storage

- Keep all nuts, bolts, and screws tight to be sure the equipment is in safe working condition.
- Never store the equipment with fuel in the tank inside a building where fumes may reach an open flame or spark.
- Allow the engine to cool before storing in any enclosure and do not store near flame.
- To reduce the fire hazard, keep the engine, silencer/muffler, battery compartment, cutting units, drives, and fuel storage area free of grass, leaves, or excessive grease. Clean up oil or fuel spillage.
- Replace worn or damaged parts for safety.
- If the fuel tank has to be drained, do this outdoors.
- On multi-bladed machines, take care as rotating one blade can cause other blades to rotate.
- When machine is to be parked, stored, or left unattended, lower the cutting units unless a positive mechanical lock is provided.
- Disengage drives, lower the cutting units, move traction pedal to Neutral, set parking brake, stop engine and remove key . Wait for all movement to stop before adjusting, cleaning or repairing.
- Park machine on level ground. Never allow untrained personnel to service machine.
- Use jack stands to support components when required.
- Carefully release pressure from components with stored energy.
- Disconnect battery before making any repairs. Disconnect the negative terminal first and the positive last. Reconnect positive first and negative last.

- Use care when checking blades. Wrap the blades or wear gloves, and use caution when servicing them. Only replace blades. Never straighten or weld them.
- Keep hands and feet away from moving parts. If possible, do not make adjustments with the engine running.
- Charge batteries in an open well ventilated area, away from spark and flames. Unplug charger before connecting or disconnecting from battery. Wear protective clothing and use insulated tools.
- Make sure all hydraulic line connectors are tight and all hydraulic hoses and lines are in good condition before applying pressure to the system.
- Keep your body and hands away from pin hole leaks or nozzles that eject hydraulic fluid under high pressure. Use paper or cardboard, not your hands, to search for leaks. Hydraulic fluid escaping under pressure can have sufficient force to penetrate the skin and cause serious injury. If fluid is injected into the skin it must be surgically removed within a few hours by a doctor familiar with this form of injury or gangrene may result.
- Keep hands, feet, and clothing away from moving parts and the mower discharge area and underside of the mower while the engine is running.
- Fill fuel tank until level is 25 mm (1 inch) below the bottom of the filler neck. Do not overfill.
- Check the safety interlock switches daily for proper operation. If a switch should fail, replace the switch before operating the machine.
- Check carefully for overhead clearances (i.e. branches, doorways, electrical wires) before driving under any objects and do not contact them.
- Do not mow in reverse unless absolutely necessary.
- Reduce speed when making sharp turns.
- Avoid starting or stopping on a slope. If tires lose traction, disengage the blades and proceed slowly straight down the slope. Avoid raising the side cutting units on a slope.
- Avoid turning on slopes. If you must turn, turn slowly and gradually downhill, if possible.
- When operating a machine with a ROPS, always use a seat belt.
- Be certain that the seat belt can be released quickly if the machine is driven or rolls into a pond or water.
- Watch for traffic when near or crossing roads. Always yield the right-of-way.
- This machine is not designed or equipped for on-road use and is a “slow-moving vehicle”. If you must cross or travel on a public road, you should be aware of and comply with local regulations, such as required lights, slow moving vehicle signs, and reflectors.
- Do not mow near drop-offs, ditches, or embankments. The machine could suddenly turn over if a wheel goes over the edge of a cliff or ditch, or if an edge caves in.
- Do not mow on wet grass. Reduced traction could cause sliding.
- Use extra care with other attachments. These can change the stability of the machine.
- Turn off the blades when not mowing.

Toro Mower Safety

The following list contains safety information specific to Toro products or other safety information that you must know that is not included in the CEN, ISO, or ANSI standards.

This product is capable of amputating hands and feet and throwing objects. Always follow all safety instructions to avoid serious injury or death.

Use of this product for purposes other than its intended use could prove dangerous to user and bystanders.

▲ WARNING

Engine exhaust contains carbon monoxide, which is an odorless, deadly poison that can kill you.

Do not run engine indoors or in an enclosed area.

Operation

- Before operating a machine with ROPS (roll over protection system), be certain that the seat belts are attached and the seat is latched to prevent the seat from pivoting forward.
- Know how to stop the machine and engine quickly.
- Do not operate the machine while wearing tennis shoes or sneakers.
- Wearing safety shoes and long pants is advisable and required by some local ordinances and insurance regulations.

Maintenance and Storage

- Do not touch equipment or attachment parts which may be hot from operation. Allow to cool before attempting to maintain, adjust, or service.
- Never store the machine or fuel container inside where there is an open flame, such as near a water heater or furnace.
- Keep nuts and bolts tight, especially the blade attachment bolts. Keep equipment in good condition.

- If the engine must be running to perform a maintenance adjustment, keep hands, feet, clothing, and any parts of the body away from the cutting units, attachments, and any moving parts. Keep everyone away.
- Check brake operation frequently. Adjust and service as required.
- Battery acid is poisonous and can cause burns. Avoid contact with skin, eyes, and clothing. Protect your face, eyes, and clothing when working with a battery.
- Battery gases can explode. Keep cigarettes, sparks, and flames away from the battery.
- The engine must be shut off before checking the oil or adding oil to the crankcase.
- If major repairs are ever needed or if assistance is desired, contact an Authorized Toro Distributor.
- To make sure of optimum performance and continued safety certification of the machine, use only genuine Toro replacement parts and accessories. Replacement parts and accessories made by other manufacturers could be dangerous, and such use could void the product warranty.

Uncertainty Value (K) = 0.17 m/s²

Measured values were determined according to the procedures outlined in EN 836.

Engine Emission Certification

The engine in this machine is EPA Tier 4 Final and stage 3b compliant.

Sound Power Level

This unit has a guaranteed sound power level of 105 dBA, which includes an Uncertainty Value (K) of 1 dBA.

Sound power level was determined according to the procedures outlined in ISO 11094.

Sound Pressure Level

This unit has a sound pressure level at the operator's ear of 94 dBA, which includes an Uncertainty Value (K) of 1 dBA.

Sound pressure level was determined according to the procedures outlined in EN 836.

Vibration Level

Hand-Arm

Measured vibration level for right hand = .92 m/s²

Measured vibration level for left hand = 1 m/s²

Uncertainty Value (K) = 0.5 m/s²

Measured values were determined according to the procedures outlined in EN 836.

Whole Body

Measured vibration level = 0.34 m/s²

Safety and Instructional Decals



Safety decals and instructions are easily visible to the operator and are located near any area of potential danger. Replace any decal that is damaged or lost.

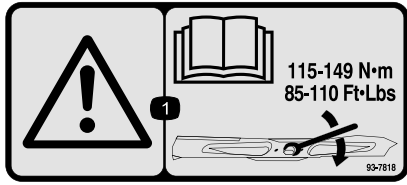

93-7818

decal93-7818

1. Warning—read the *Operator's Manual* for instructions on torquing the blade bolt/nut to 115-149 N-m (85-110 ft-lb).

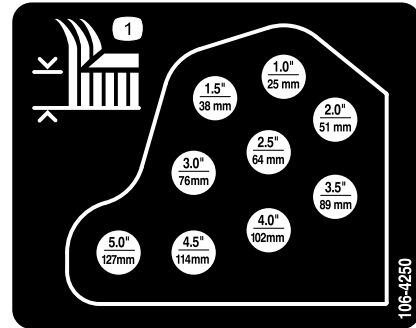

106-4250

decal106-4250

1. Height of cut

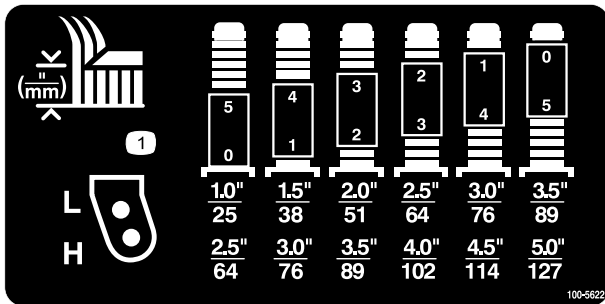

100-5622

decal100-5622

1. Height of cut adjustment

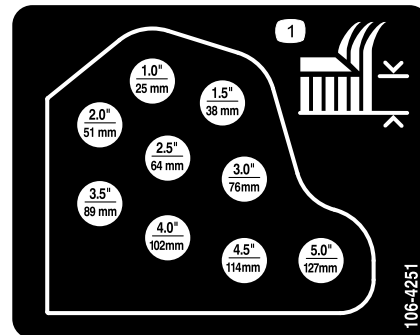

106-4251

decal106-4251

1. Height of cut

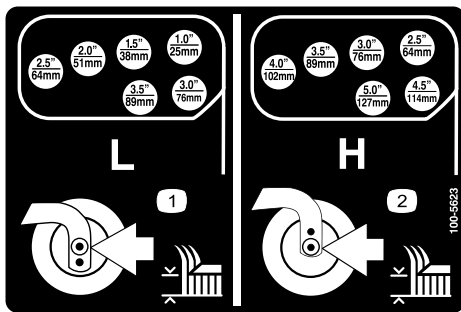

100-5623

decal100-5623

1. Low height of cut adjustment
2. High height of cut adjustment

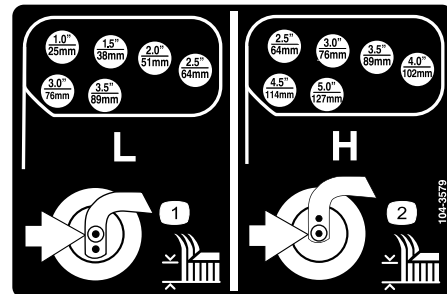

104-3579

decal104-3579

1. Low height of cut adjustment
2. High height of cut adjustment

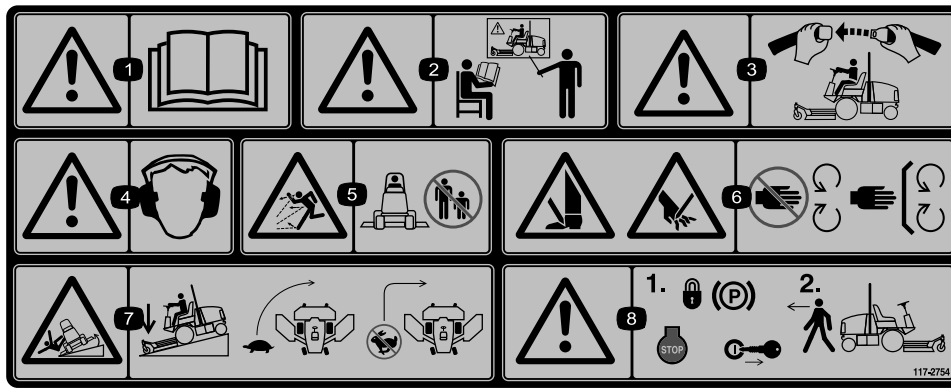

117-2754

decal117-2754

1. Warning—read the *Operator's Manual*.
2. Warning—do not operate this machine unless you are trained.
3. Warning—wear the seat belt when seated in the operator's position.
4. Warning—wear hearing protection.
5. Thrown object hazard—keep bystanders a safe distance from the machine.
6. Cutting hazard of hand or foot—stay away from moving parts; keep all guards in place.
7. Tipping hazard—lower the cutting unit when driving down slopes; slow machine before turning, do not turn at high speeds
8. Warning—lock the parking brake, stop the engine and remove the ignition key before leaving the machine.

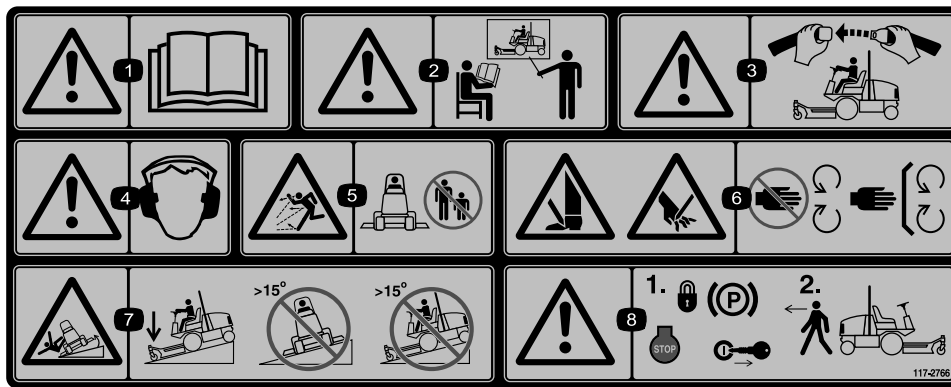

117-2766

decal117-2766

(Affix over part no. 117-2754 for CE*)

* This safety decal includes a slope warning required on the machine for compliance to the European Lawn Mower Safety Standard EN836:1997. The conservative maximum slope angles indicated for operation of this machine are prescribed by and required by this standard.

1. Warning—read the *Operator's Manual*.
2. Warning—do not operate this machine unless you are trained.
3. Warning—wear the seat belt when seated in the operator's position.
4. Warning—wear hearing protection.
5. Thrown object hazard—keep bystanders a safe distance from the machine.
6. Cutting hazard of hand or foot—stay away from moving parts; keep all guards in place.
7. Tipping hazard—lower the cutting unit when driving down slopes; do not operate machine on slopes greater than 15 degrees.
8. Warning—lock the parking brake, stop the engine and remove the ignition key before leaving the machine.

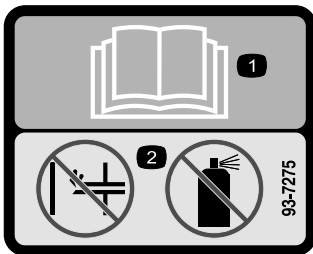

93-7275

decal93-7275

1. Read the *Operator's Manual*.
2. Do not use starting aids.

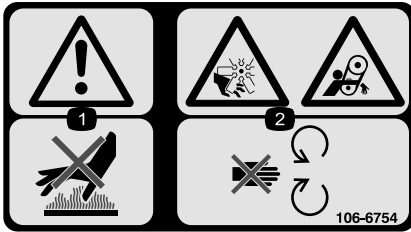

106-6754

decal106-6754

1. Warning—do not touch the hot surface.
2. Cutting/dismemberment hazard, fan and entanglement hazard, belt—stay away from moving parts.

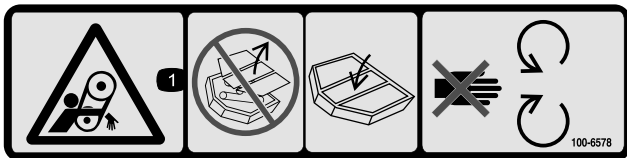

100-6578

decal100-6578

1. Entanglement hazard, belt—do not operate the machine with the shields or guards removed; always keep the shields and guards in place; stay away from moving parts.

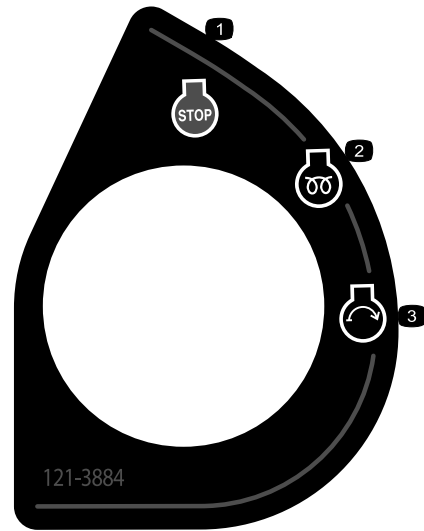

121-3884

decal121-3884

1. Engine—stop
2. Engine—preheat
3. Engine—start

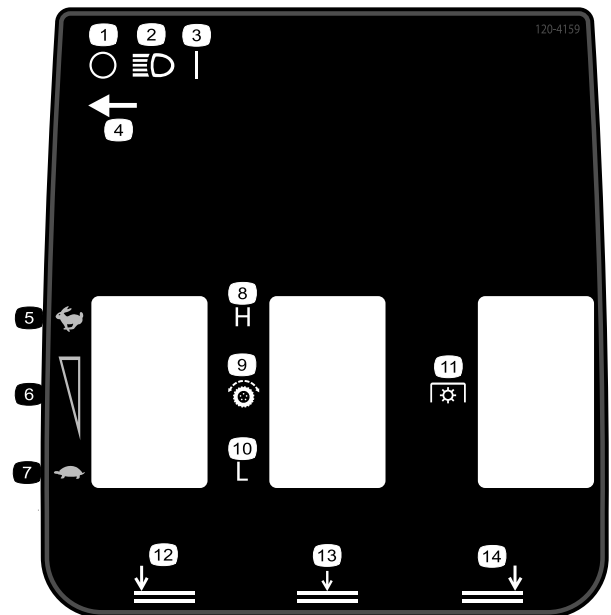

120-4159

decal120-4159

- | | |
|------------------------------|--------------------------|
| 1. Off | 8. High |
| 2. Lights | 9. Traction drive |
| 3. On | 10. Low |
| 4. Light switch location | 11. Power take-off (PTO) |
| 5. Fast | 12. Lower left deck |
| 6. Variable speed adjustment | 13. Lower center deck |
| 7. Slow | 14. Lower right deck |

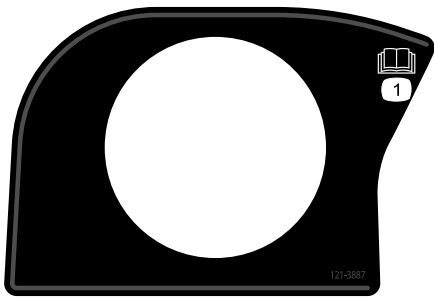

121-3887

decal121-3887

1. Read the *Operator's Manual*.



1

58-6520

decal58-6520

1. Grease

CALIFORNIA SPARK ARRESTER WARNING
 Operation of this equipment may create sparks that can start fires around dry vegetation. A spark arrester may be required. The operator should contact local fire agencies for laws or regulations relating to fire prevention requirements. 117-2718

117-2718

decal117-2718

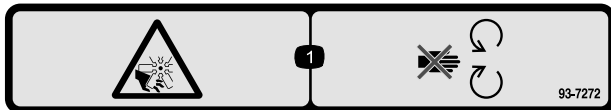

93-7272

decal93-7272

1. Cutting/dismemberment hazard; fan—stay away from moving parts.

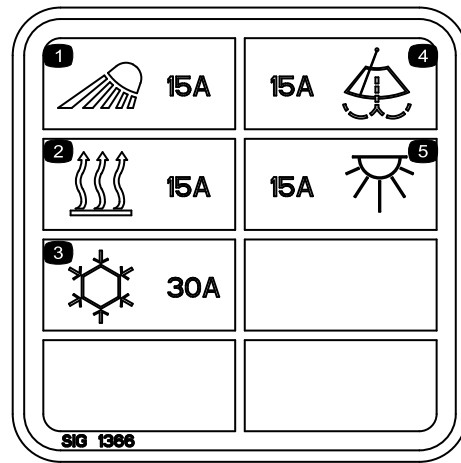

117-2787

(Cab models)

decal117-2787

1. Headlights, 15A fuse
2. Heater, 15A fuse
3. Air conditioning, 30A fuse
4. Windshield wipers, 15A fuse
5. Dome light, 15A fuse

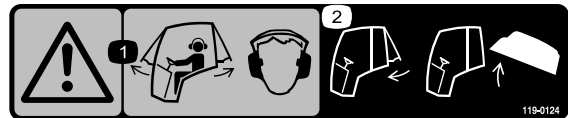

119-0124

(Cab models)

decal119-0124

1. Warning—when the cab windows are open wear hearing protection.
2. Close the rear window before attempting to open the hood.

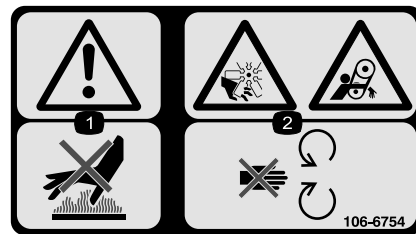

106-6754

decal106-6754

1. Warning—do not touch the hot surface.
2. Cutting/dismemberment hazard, fan and entanglement hazard, belt—stay away from moving parts.



106-6755

decal106-6755

1. Engine coolant under pressure.
2. Explosion hazard—read the *Operator's Manual*.
3. Warning—do not touch the hot surface.
4. Warning—read the *Operator's Manual*.

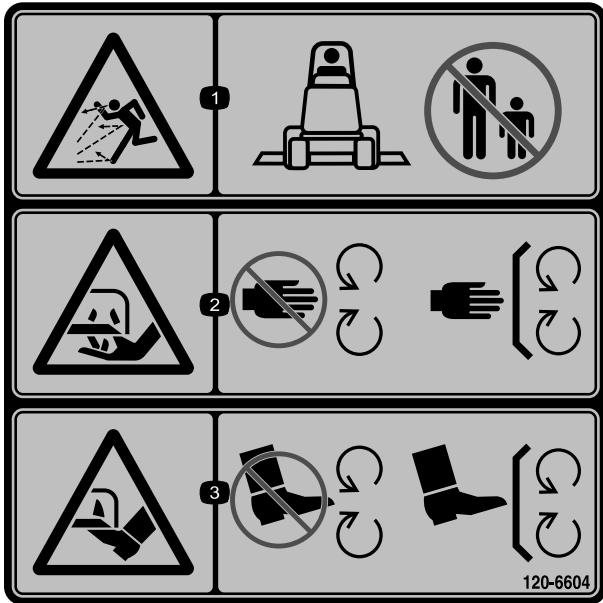

120-6604

decal120-6604

1. Thrown object hazard—keep bystanders away from the machine.
2. Cutting/dismemberment hazard of hand, mower blade—stay away from moving parts, keep all guards and shields in place.
3. Cutting/dismemberment hazard of foot, mower blade—stay away from moving parts, keep all guards and shields in place.

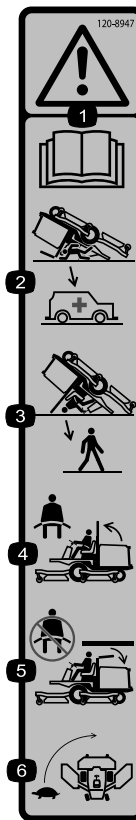

120-8947

decal120-8947

1. Warning—read the *Operator's Manual*.
2. There is no rollover protection when the roll bar is down.
3. There is rollover protection when the roll bar is up.
4. If the roll bar is raised, wear the seat belt.
5. If the roll bar is lowered, do not wear the seat belt.
6. Drive slowly when turning.

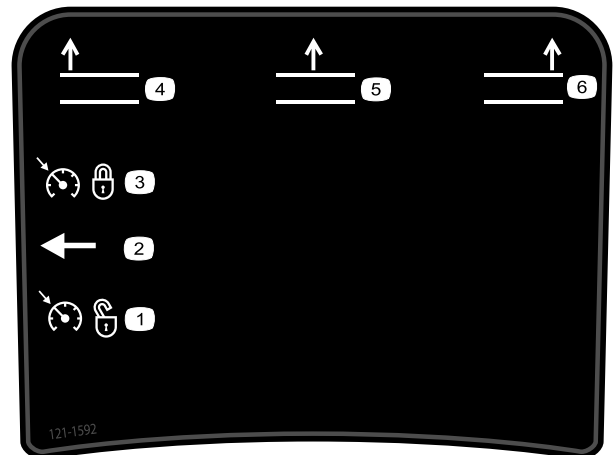

121-1592

decal121-1592

1. Cruise control not set
2. Cruise control switch
3. Cruise control set
4. Raise the left deck
5. Raise the middle deck
6. Raise the right deck

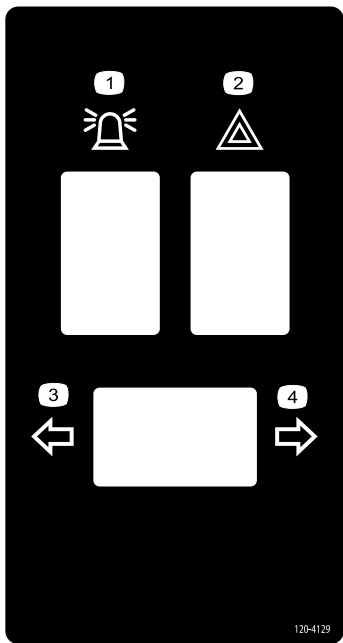

120-4129

decal120-4129

1. Beacon
2. Hazard light
3. Left turn signal
4. Right turn signal

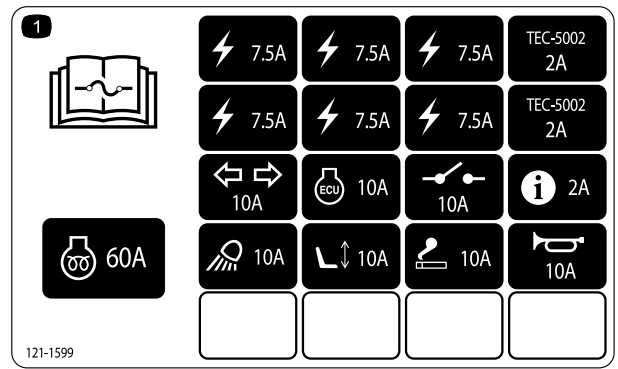

121-1599

decal121-1599

1. Read the *Operator's Manual* for information on fuses.

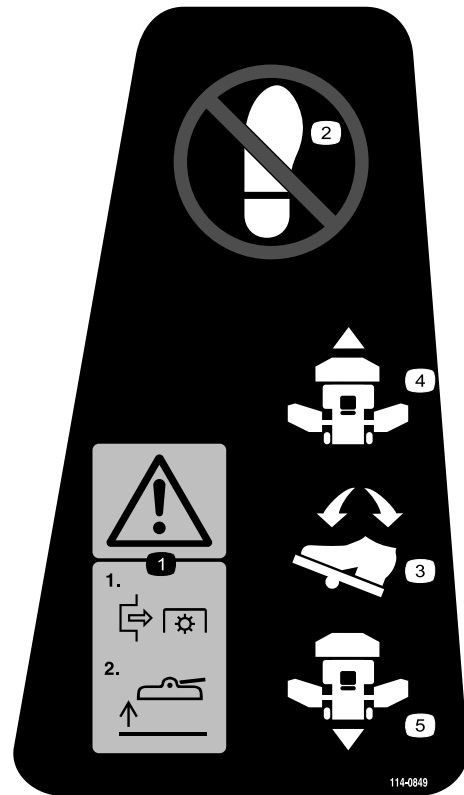

114-0849

decal114-0849

1. Warning—1)Disengage the PTO; 2)Raise the deck
2. Do not place your foot here.
3. Direction pedal
4. Forward direction
5. Reverse direction

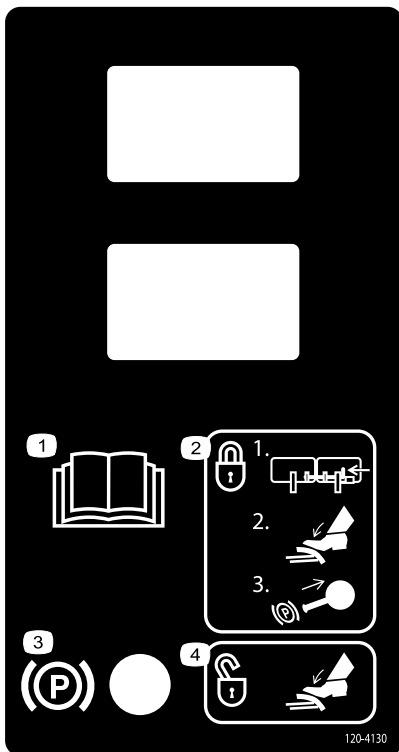

120-4130

decal120-4130

1. Read the *Operator's Manual*.
2. To engage the parking brake—1)Lock the pedals together; 2)Push down on the brake; 3)Pull out the parking brake knob.
3. Parking brake
4. To disengage the parking brake, push down on the brake pedal.

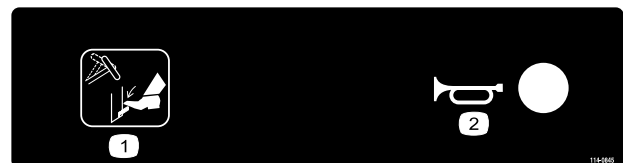

114-0845

decal114-0845

1. Steering wheel tilt lever
2. Horn

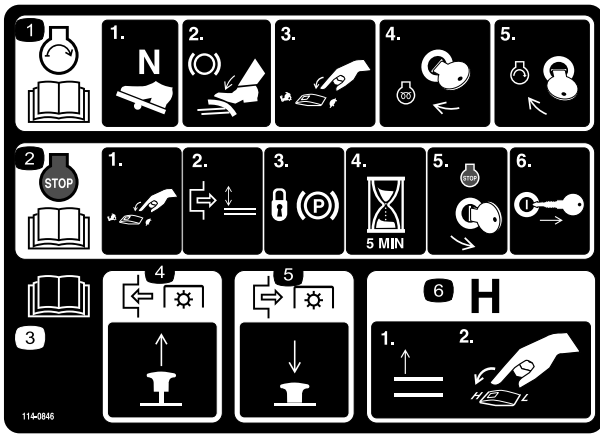

114-0846

decal114-0846

1. Read the *Operator's Manual* for information on starting the engine—1)Set to neutral; 2)Engage the brake; 3)Set the engine speed to slow; 4)Turn the ignition key to preheat; 5)Turn the ignition key to engine start.
2. Read the *Operator's Manual* for information on stopping the engine—1)Set the engine speed to slow; 2)Disengage the deck; 3)Lock the parking brake; 4)Wait 5 minutes; 5)Turn the ignition key to engine stop; 6)Remove the key from the ignition.
3. Read the *Operator's Manual*.
4. Pull the knob out to engage the PTO.
5. Push the knob in to disengage the PTO.
6. Raise the decks to go to H range.



Battery Symbols

Some or all of these symbols are on your battery

1. Explosion hazard
2. No fire, open flame, or smoking.
3. Caustic liquid/chemical burn hazard
4. Wear eye protection
5. Read the *Operator's Manual*.
6. Keep bystanders a safe distance from the battery.
7. Wear eye protection; explosive gases can cause blindness and other injuries
8. Battery acid can cause blindness or severe burns.
9. Flush eyes immediately with water and get medical help fast.
10. Contains lead; do not discard.

GROUNDMASTER 4100, MODELS 30606 & 30608 QUICK REFERENCE AID

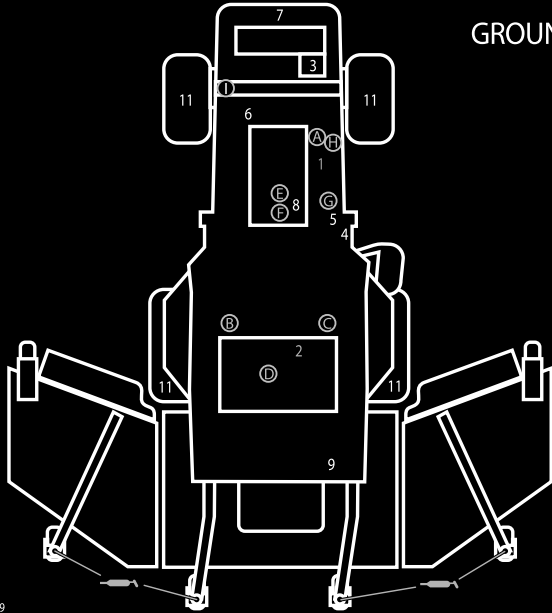

121-1679

CHECK/SERVICE (DAILY)

1. ENGINE OIL LEVEL
2. HYDRAULIC FLUID LEVEL
3. ENGINE COOLANT LEVEL
4. FUEL - DIESEL ONLY
5. FUEL/WATER SEPARATOR
6. FAN BELT TENSION
7. RADIATOR SCREEN

8. AIR CLEANER

9. BRAKE FUNCTION

10. INTERLOCK SYSTEM

11. TIRE PRESSURE - 25 PSI/1.70 BAR

12. GREASE POINTS (4)

SEE OPERATOR'S MANUAL FOR 50 HR INTERVAL GREASE POINTS.

1 

SPECIFICATIONS/CHANGE INTERVALS

| SEE OPERATOR'S MANUAL FOR INITIAL CHANGES. | FLUID TYPE | CAPACITY | CHANGE INTERVAL | | FILTER PART NO. |
|--|-------------------------------|---------------------------------|----------------------------|-----------------------|--|
| | | | FLUID | FILTER | |
| ENGINE OIL | 15W-40 CJ-4 | 6 QUARTS | 250 HOURS | 250 HOURS | 125-7025 (A) |
| HYDRAULIC FLUID | ISO VG 46/68 | 7.75 GALLONS | 800 HOURS | 800 HOURS | 75-1310 (B) 94-2621 (C) |
| HYDRAULIC BREATHER | | | | 800 HRS/YRLY | 115-9793 (D) |
| PRIMARY AIR FILTER | | | | SEE SERVICE INDICATOR | 108-3814 (E) |
| SAFETY AIR FILTER | | | | SEE OPERATOR'S MANUAL | 108-3816 (F) |
| FUEL SYSTEM | > 32 F | NO. 2 DIESEL | 21 GALLONS | 800 HOURS DRAIN/FLUSH | 125-2915 WATER SEPARATOR 125-8752 (H) |
| | < 32 F | NO. 1 DIESEL | | | |
| REAR AXLE | 85W-140 | 80 OUNCES | 800 HOURS | | 110-4812 BREATHER (I) |
| PLANETARY DRIVE | 85W-140 | 22 OUNCES | 800 HOURS | | |
| ENGINE COOLANT | 50% WATER 50% ETHYL GLYCOL | 9 QUARTS (14.5 QUARTS WITH CAB) | DRAIN & FLUSH EVERY 2 YRS. | | |

121-1679

decal121-1679

1. Read the *Operator's Manual* for maintenance information.

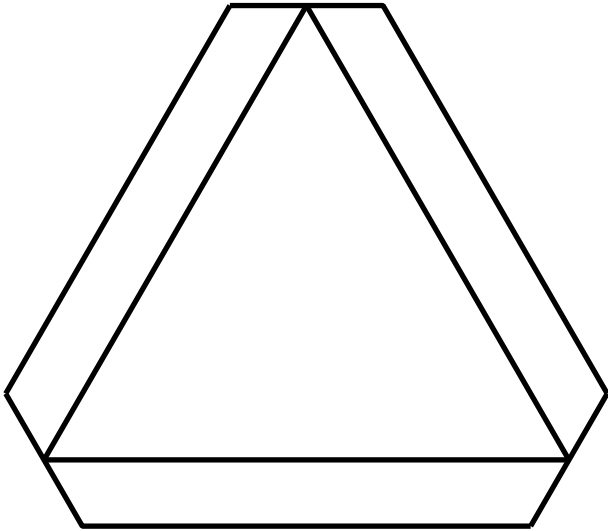

decal120-0250

120-0250
(Cab models)

1. Slow moving vehicle

Setup

Loose Parts

Use the chart below to verify that all parts have been shipped.

| Procedure | Description | Qty. | Use |
|-----------|-------------------|------|---|
| 1 | No parts required | – | Grease the machine. |
| 2 | Warning Decal | 1 | Used only on machines requiring European CE compliance. |

Media and Additional Parts

| Description | Qty. | Use |
|-----------------------------|------|-------------------------------------|
| Operator's Manual | 1 | Review before operating machine |
| Engine Operator's Manual | 1 | Use to reference engine information |
| Parts Catalog | 1 | Use to reference part numbers |
| Operator Training Materials | 1 | Review before operating machine |
| Declaration of conformity | 1 | |

Note: Determine the left and right sides of the machine from the normal operating position.



Greasing the Machine

No Parts Required

Procedure

Before the machine is operated, it must be greased to ensure proper lubricating characteristics; refer to Greasing the Bearings and Bushings in Lubrication. Failure to properly grease the machine will result in premature failure of critical parts.



Replacing the Warning Decal

Parts needed for this procedure:

| | |
|---|----------------------|
| 1 | <i>Warning Decal</i> |
|---|----------------------|

Procedure

On machines requiring European CE compliance, replace the warning decal, part no. 117–2754 with the warning decal part no. 117–2766.

Product Overview

Controls

Note: Determine the left and right sides of the machine from the normal operating position.

⚠ CAUTION

This machine produces sound levels in excess of 85 dBA at the operators ear and can cause hearing loss through extended periods of exposure.

Wear hearing protection when operating this machine.

Traction Pedal

To stop, reduce your foot pressure on the traction pedal and allow it to return to the center position (Figure 3).

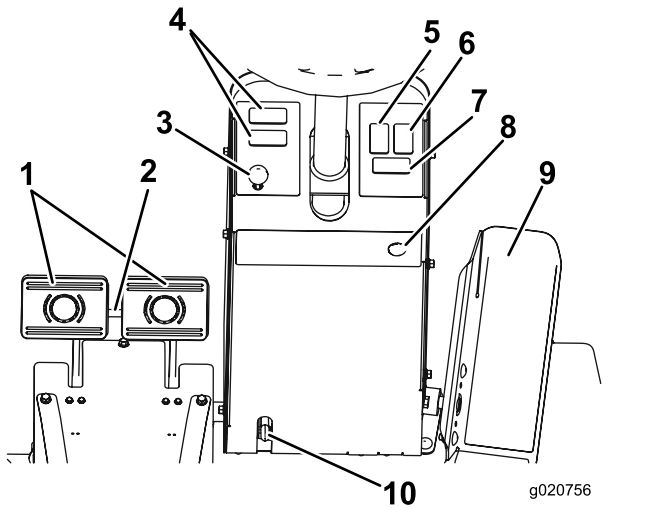

Figure 3

- | | |
|---------------------------------|---------------------------|
| 1. Brake pedals | 6. Hazard light switch |
| 2. Pedal locking latch | 7. Turn signal switch |
| 3. Parking brake latch | 8. Horn button (optional) |
| 4. Space for optional accessory | 9. Traction pedal |
| 5. Beacon switch (optional) | 10. Tilt steering lever |

Brake Pedals

Two foot pedals (Figure 3) operate individual wheel brakes for turning assistance, parking, and to aid in obtaining better side hill traction. A latch connects the pedals for parking brake operation and transport.

Pedal Locking Latch

The pedal locking latch (Figure 3) connects the pedals together to engage the parking brake.

Tilt Steering Lever

Press the lever (Figure 3) down to tilt the steering wheel to the desired position. Then release the lever to lock the adjustment.

Parking Brake Latch

A knob on the left side of the console actuates the parking brake lock (Figure 3). To engage the parking brake, connect the pedals with the locking latch, push down on both pedals, and pull the parking brake latch out. To release the parking brake, press both pedals until the parking brake latch retracts.

Hazard Light Switch

Press the hazard light switch (Figure 3) to activate the hazard lights.

Turn Signal Switch

Press the left side of the turn signal switch (Figure 3) to activate the left turn signal and the right side of the switch to activate the right turn signal. The center position is off.

Key Switch

The key switch (Figure 4) has three positions: Off, On/Preheat, and Start.

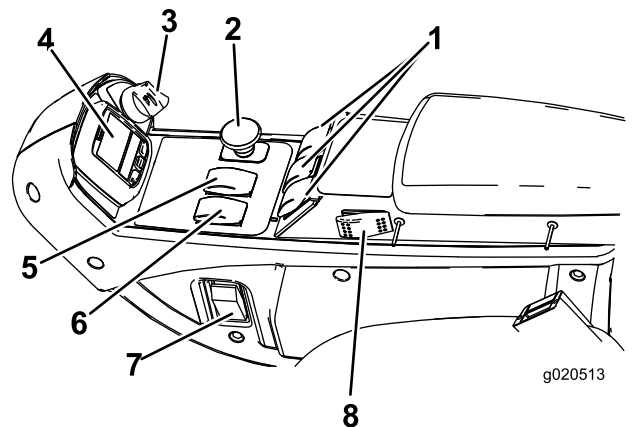

Figure 4

- | | |
|------------------|----------------------------|
| 1. Lift switches | 5. Hi-Lo speed control |
| 2. PTO switch | 6. Engine speed switch |
| 3. Key switch | 7. Light switch (optional) |
| 4. InfoCenter | 8. Cruise control switch |

Engine Speed Switch

The engine speed switch (Figure 4) has two modes to change the engine speed. By momentarily tapping the switch, the engine speed can be increased or decreased in 100 rpm increments. By holding the switch down the engine will automatically move to High or Low idle, depending on which of the switch is depressed.

PTO Switch

The PTO switch (Figure 4) has two positions: Out (start) and In (stop). Pull the PTO button out to engage the cutting unit blades. Push in the button to disengage the cutting unit blades.

Hi-Lo Speed Control

The switch (Figure 4) allows the speed range to increase for transport of the machine. Cutting decks will not operate in high range. To switch between the High and Lo range, the decks must be raised, PTO disengaged, cruise control disengaged, traction pedal in neutral position and the machine must be moving at a slow speed.

Lift Switches

The lift switches (Figure 4) raise and lower the cutting units. Press the switches forward to lower the cutting units and backward to raise the cutting units. When starting the machine, with the cutting units in the down position, press the lift switch down to allow the cutting units to float and mow.

Note: The decks will not lower while in the HI speed range and they will not raise or lower if the operator is out of the seat when the engine is running. Also, the decks will lower with the key in the On position and the operator in the seat.

Cruise Control Switch

The cruise control switch (Figure 4) sets the speed of the machine. Pressing the rear of the switch turns off the cruise control, the middle position of the switch enables the cruise control function and the front of the switch sets the desired ground speed.

Note: Pressing either brake pedal or moving the traction pedal into the reverse position, for one second, will also disengage the cruise control.

Power Point

The power point (Figure 5) is used to power optional electrical accessories.

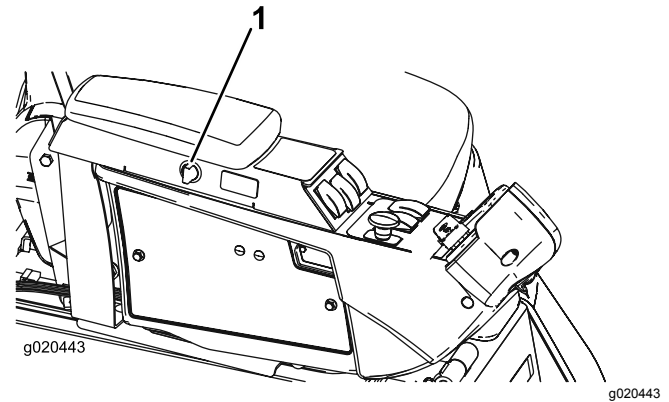

Figure 5

1. Power point

Seat Adjustments

Fore and Aft Adjusting Lever

Pull out on the lever to slide the seat fore or aft (Figure 6).

Seat Arm Rest Adjusting Knob

Rotate the knob to adjust the seat arm rest angle (Figure 6).

Seat Back Adjusting Lever

Move the lever to adjust the seat back angle (Figure 6).

Weight gauge

Indicates when the seat is adjusted to the weight of the operator (Figure 6). Height adjustment is made by positioning the suspension within the range of the green region.

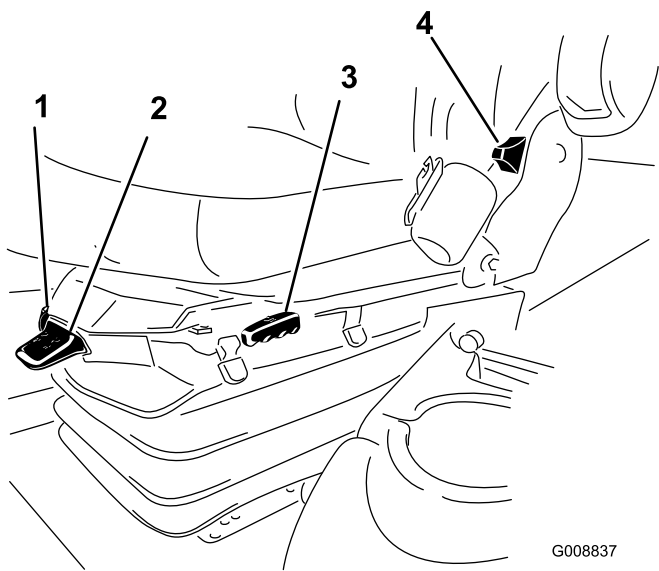

G008837

g008837

Figure 6

- | | |
|------------------------------------|---|
| 1. Weight gauge | 4. Seat back adjusting lever |
| 2. Weight adjusting lever | 5. Arm rest adjusting knob (not shown-located under arm rest) |
| 3. Fore and Aft adjusting lever | |

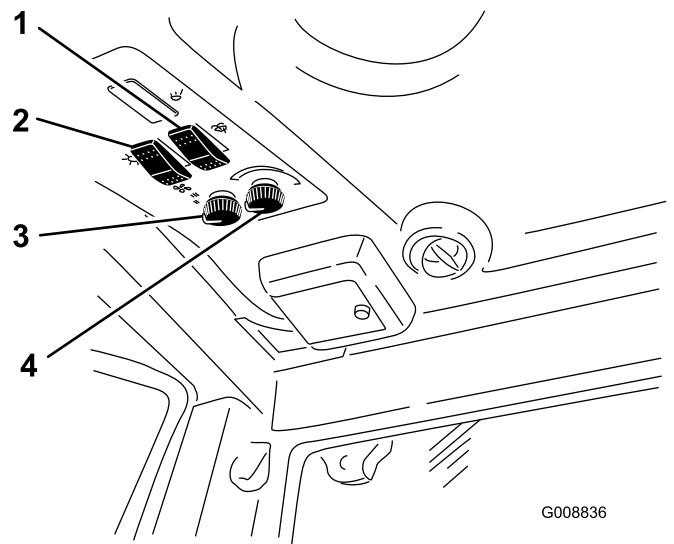

G008836

g008836

Figure 7

- | | |
|-----------------------------|------------------------|
| 1. Wind shield wiper switch | 3. Fan control |
| 2. Air conditioning switch | 4. Temperature control |

Weight Adjusting Lever

Adjust for operator weight (Figure 6). Pull up on the lever to increase the air pressure and push down to decrease the air pressure. The proper adjustment is attained when the weight gauge is in the green region.

Cab Controls

Cab model only

Wind Shield Wiper Switch

Press front of switch to activate the wind shield wipers (Figure 7) and rear of switch to turn off the wipers.

Air Conditioning Switch

Press front of switch to activate the air conditioning (Figure 7) and rear of switch to turn off the air conditioning.

Fan Control

Rotate the fan control knob to regulate the speed of the fan (Figure 7).

Temperature Control

Rotate the temperature control knob to regulate the air temperature in the cab (Figure 7).

Wind Shield Latch

Lift up on latches to open the wind shield (Figure 8). Press in on latch to lock wind shield in open position. Pull out and down on latch to close and secure wind shield.

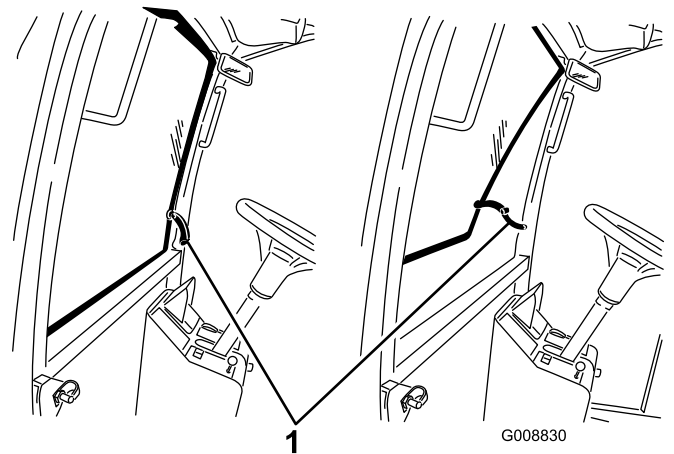

G008830

g008830

Figure 8

1. Wind shield latch

Rear Window Latch

Lift up on latches to open the rear window. Press in on latch to lock window in open position. Pull out and down on latch to close and secure window (Figure 8).

Important: The rear window must be closed before opening the hood or damage may occur.

Using the InfoCenter Control

The InfoCenter LCD display shows information about your machine, such as the operating status, various diagnostics and other information about the machine (Figure 9). There is a splash screen and main information screen of the InfoCenter. You can switch between the splash screen and main information screen at any time by pressing any of the InfoCenter buttons and then selecting the appropriate directional arrow.

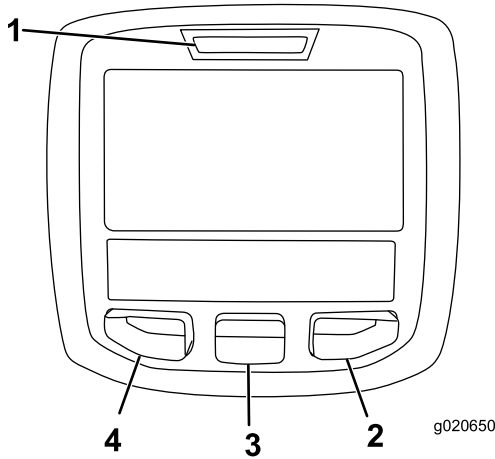

Figure 9

- 1. Indicator light
- 2. Right button
- 3. Middle button
- 4. Left button















- Left Button, Menu Access/Back Button—press this button to access the InfoCenter menus. You can use it to exit any menu that you are currently using.
- Middle Button—use this button to scroll down menus.
- Right Button—use this button to open a menu where a right arrow indicates additional content.
- Beeper—activated when lowering the decks or for advisories and faults.

Note: The purpose of each button may change depending on what is required at the time. Each button is labeled with an icon displaying its current function.







InfoCenter Icon Description

| | |
|--------------------|---|
| SERVICE DUE | Indicates when scheduled service should be performed |
| | Engine rpm/status—indicates the engine rpm |
| | Hour meter |
| | Info icon |
| | Sets the maximum traction speed |
| | Fast |
| | Slow |
| | Fan Reversal—indicates when the fan is reversed |
| | Fuel level |
| | Stationary regeneration required |
| | Air intake heater is active |
| | Raise the left deck |
| | Raise the center deck |
| | Raise the right deck |
| | Operator must sit in seat |
| | Parking Brake Indicator—indicates when the parking brake is on |
| | Identifies the range as High |
| | Neutral |
| | Identifies the range as Low |
| | Coolant Temperature—indicates the engine coolant temperature in either °C or °F |
| | Temperature (hot) |
| | Traction or Traction Pedal |

InfoCenter Icon Description (cont'd.)

| | |
|---|---|
|  | Denied or not allowed |
|  | Engine Start |
|  | PTO—indicates that the PTO is on |
|  | Stop or shutdown |
|  | Engine |
|  | Key switch |
|  | Indicates when the mower decks are being lowered |
|  | Indicates when the mower decks are being raised |
|  | PIN code |
|  | Hydraulic-Oil Temperature—indicates the hydraulic-oil temperature |
| CAN | CAN bus |
|  | InfoCenter |
| Bad | Bad or failed |
| Ctr | Center |
| Rht | Right |
| Left | Left |
|  | Bulb |
| OUT | Output of TEC controller or control wire in harness |
| HI | High: over-allowed range |
| LO | Low: under-allowed range |
| HI / LO | Out of range |
|  | Switch |
|  | Operator must release the switch |

InfoCenter Icon Description (cont'd.)

| | |
|---|---|
|  | Operator should change to the indicated state |
| Symbols are often combined to form sentences. Some examples are shown below | |
|  | Operator should put the machine in neutral |
|  | Engine start denied |
|  | Engine shutdown |
|  | Engine coolant is too hot |
|  | Hydraulic fluid is too hot |
|  | Sit down or engage the parking brake |

Using the Menu

To access the InfoCenter menu system, press the menu access button while at the main screen. This will bring you to the main menu. Refer to the following tables for a synopsis of the options available from the menus:

| Main Menu | |
|-------------|---|
| Menu Item | Description |
| Faults | The Faults menu contains a list of the recent machine faults. Refer to the Service Manual or your Authorized Toro Distributor for more information on the Faults menu and the information contained there. |
| Service | The Service menu contains information on the machine such as hours of use and other similar numbers. |
| Diagnostics | The Diagnostics menu displays the state of each machine switch, sensor and control output. You can use this to troubleshoot certain issues as it will quickly tell you which machine controls are on and which are off. |

| | |
|----------|---|
| Settings | The Settings menu allows you to customize and modify configuration variables on the InfoCenter display. |
| About | The About menu lists the model number, serial number, and software version of your machine. |

| Service | |
|-----------|--|
| Menu Item | Description |
| Hours | Lists the total number of hours that the machine, engine and fan have been on, as well as the number of hours the machine has been transported and has overheated. |
| Counts | Lists the number of preheats and starts the machine has experienced. |

| Diagnostics | |
|-------------|--|
| Menu Item | Description |
| Engine Run | Refer to the Service Manual or your Authorized Toro Distributor for more information on the Engine Run menu and the information contained there. |
| Glowplugs | Indicates if the following items are active: Key start, timeout limited, and glowplugs. |
| Fan | Indicates if the fan is active in the following instances: Engine high temp, oil high temp, engine or hydraulic high temp, and fan on. |

| Settings | |
|----------------|--|
| Menu Item | Description |
| Units | Controls the units used on the InfoCenter. The menu choices are English or Metric |
| Language | Controls the language used on the InfoCenter*. |
| LCD Backlight | Controls the brightness of the LCD display. |
| LCD Contrast | Controls the contrast of the LCD display. |
| Protected Menu | Allows a person authorized by your company with the PIN code to access protected menus. |
| Auto Idle | Controls the amount of time allowed before idling the engine when the machine is not in use. |

| | |
|-------------|--|
| Mow Speed | Controls the maximum speed while in mow (low range). |
| Trans Speed | Controls the maximum speed while in transport (high range). |
| Smart Power | Smart Power prevents bogging down in heavy turf by automatically controlling the machine speed and optimizing cutting performance. |

* Only "operator-faced" text is translated. Faults, Service, and Diagnostics screens are "service-faced". Titles will be in the selected language, but menu items are in English.

| About | |
|-----------------------------|---|
| Menu Item | Description |
| Model | Lists the model number of the machine. |
| SN | Lists the serial number of the machine. |
| Machine Controller Revision | Lists the software revision of the master controller. |
| InfoCenter Revision | Lists the software revision of the InfoCenter. |
| CAN Bus | Lists the machine communication bus status. |

Protected Menus

There are 4 operating configuration settings that are adjustable within the Settings Menu of the InfoCenter: auto idle time delay, maximum mowing ground speed, maximum transport ground speed, and Smart Power. These settings are in the Protected Menu.

Accessing Protected Menus

Note: The factory default PIN code for you machine is either 0000 or 1234.

If you changed the PIN code and forgot the code, contact your Authorized Toro Distributor for assistance.

1. From the MAIN MENU, use the center button to scroll down to the SETTINGS MENU and press the right button (Figure 10).

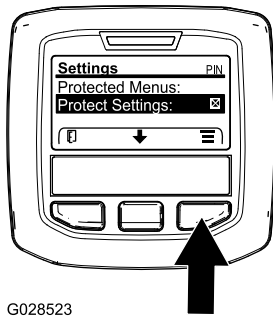

G028523

Figure 10

g028523

- In the SETTINGS MENU, use the center button to scroll down to the PROTECTED MENU and press the right button (Figure 11A).

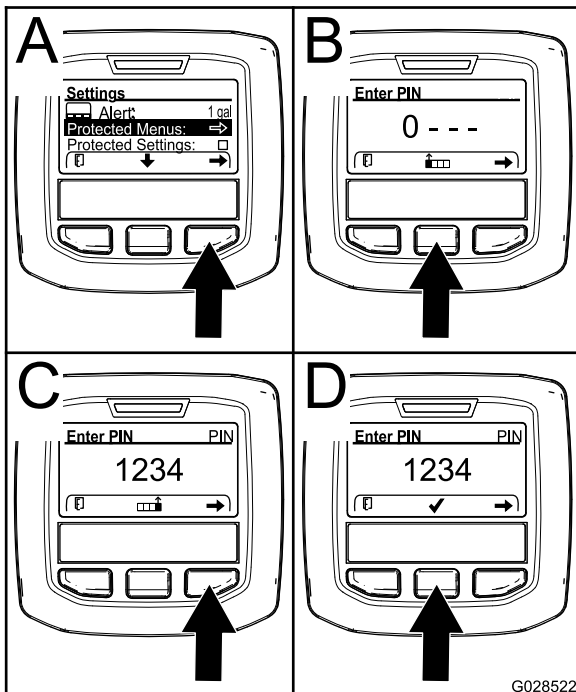

G028522

Figure 11

g028522

- To enter the PIN code, press the center button until the correct first digit appears, then press the right button to move on to the next digit (Figure 11B and Figure 11C). Repeat this step until the last digit is entered and press the right button once more.
- Press the middle button to enter the PIN code (Figure 11D).

Wait until the red indicator light of the InfoCenter illuminates.

Note: If the InfoCenter accepts the PIN code and the protected menu is unlocked, the word “PIN” displays in the upper right corner of the screen.

Note: Rotate the key switch to the OFF position and then to the ON position locks the protected menu.

You have the ability to view and change the settings in the Protected Menu. Once you access the Protected Menu, scroll down to Protect Settings option. Use the right button to change the setting. Setting the Protect Settings to OFF allows you to view and change the settings in the Protected Menu without entering the PIN code. Setting the Protect Settings to ON hides the protected options and requires you to enter the PIN code to change the setting in the Protected Menu. After you set the PIN code, rotate the key switch OFF and back to the ON position to enable and save this feature.

To Set the Auto Idle

- In the Settings Menu, scroll down to Auto Idle.
- Press the right button to change the auto idle time between OFF, 8S, 10S, 15S, 20S, & 30S.

To Set the Maximum Allowed Mow Speed

- In the Settings Menu, Scroll down to Mow Speed and press the right button.
- Use the right button to increase the max full mow speed (50%, 75%, or 100%).
- Use the center button to decrease the max full mow speed (50%, 75%, or 100%).
- Press the left button to exit.

To Set the Maximum Allowed Transport Speed

- In the Settings Menu, scroll down to Transport Speed and press the right button.
- Use the right button to increase the max transport speed (50%, 75%, or 100%).
- Use the center button to decrease the max transport speed (50%, 75%, or 100%).
- Press the left button to exit.

When finished with the Protected Menu, press the left button to exit to the Main Menu, then press the left button to exit to the Run Menu.

Specifications

Note: Specifications and design are subject to change without notice.

| | |
|---------------------------------|------------------------|
| Width of cut | |
| overall | 315 cm (124 inches) |
| front cutting unit | 137 cm (54 inches) |
| side cutting unit | 94 cm (37 inches) |
| front and one side cutting unit | 226 cm (89 inches) |
| Overall width | |
| cutting units down | 323 cm (127 inches) |
| cutting units up (transports) | 180 cm (71 inches) |
| Overall length | 366 cm (144 inches) |
| Height | 140 cm (55 inches) |
| Height with ROPS | 217 cm (85.3 inches) |
| Height with cab | 237 cm (93.3 inches) |
| Ground clearance | 15 cm (6 inches) |
| Wheel tread (to center of tire) | |
| front | 114 cm (45 inches) |
| rear | 107 cm (42 inches) |
| Wheel base | 141 cm (55-1/2 inches) |
| (Net Weight) | 1922 kg (4237 lbs) |
| (Net Weight with cab) | 2165 kg (4774 lbs) |

Attachments/Accessories

A selection of Toro approved attachments and accessories is available for use with the machine to enhance and expand its capabilities. Contact your Authorized Service Dealer or Distributor or go to www.Toro.com for a list of all approved attachments and accessories.

Operation

Note: Determine the left and right sides of the machine from the normal operating position.

Before Operating

⚠ CAUTION

If you leave the key in the ignition switch, someone could accidentally start the engine and seriously injure you or other bystanders.

Remove the key from the ignition before you do any maintenance.

Checking the Engine-Oil Level

Before you start the engine and use the machine, check the oil level in the engine crankcase; refer to [Servicing the Engine Oil \(page 53\)](#).

Checking the Cooling System

Service Interval: Before each use or daily

Check level of coolant at the beginning of each day. Capacity of system is 8.52 liters (9 qts) for the Groundsmaster 4100 and 20 liters (14.5 qts) for the Groundsmaster 4110.

1. Carefully remove the radiator cap and expansion tank cap ([Figure 12](#)).

⚠ CAUTION

If the engine has been running, the pressurized, hot coolant can escape and cause burns.

- Do not open the radiator cap when the engine is running.
 - Use a rag when opening the radiator cap, and open the cap slowly to allow steam to escape.
2. Check the coolant level in the radiator. The radiator should be filled to the top of the filler neck and the expansion tank filled to the Full mark.

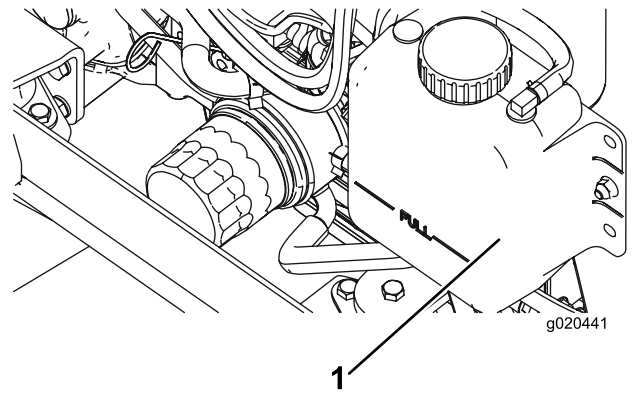

Figure 12

1. Expansion tank

3. If the coolant is low, add a 50/50 mixture of water and ethylene glycol anti-freeze. **Do not use water only or alcohol/methanol base coolants.**
4. Install the radiator cap and expansion tank cap.

Adding Fuel

⚠ DANGER

In certain conditions, fuel is extremely flammable and highly explosive. A fire or explosion from fuel can burn you and others and can damage property.

- Fill the fuel tanks outdoors, in an open area, when the engine is cold. Wipe up any fuel that spills.
- Never fill the fuel tanks inside an enclosed trailer.
- Never smoke when handling fuel and stay away from an open flame or where fuel fumes may be ignited by a spark.
- Store fuel in an approved container and keep it out of the reach of children. Never buy more than a 30-day supply of fuel.
- Do not operate without entire exhaust system in place and in proper working condition.

▲ DANGER

In certain conditions during fueling, static electricity can be released, causing a spark that can ignite the fuel vapors. A fire or explosion from fuel can burn you and others and can damage property.

- Always place fuel containers on the ground away from your vehicle before filling.
- Do not fill fuel containers inside a vehicle or on a truck or trailer bed, because interior carpets or plastic truck bed liners may insulate the container and slow the loss of any static charge.
- When practical, remove equipment from the truck or trailer and refuel the equipment with its wheels on the ground.
- If this is not possible, then refuel such equipment on a truck or trailer from a portable container rather than from a fuel-dispenser nozzle.
- If you must use a fuel-dispenser nozzle, keep the nozzle in contact with the rim of the fuel tank or container opening at all times until fueling is complete.

▲ WARNING

Fuel is harmful or fatal if swallowed. Long-term exposure to vapors can cause serious injury and illness.

- Avoid prolonged breathing of vapors.
- Keep your face away from the nozzle and fuel tank opening.
- Keep fuel away from your eyes and skin.

Fuel Specification

Important: Use only ultra-low sulphur diesel fuel. Fuel with higher rates of sulfur degrades the diesel oxidation catalyst (DOC), which causes operational problems and shortens the service life of engine components.

Failure to observe the following cautions may damage the engine.

- Never use kerosene or gasoline instead of diesel fuel.
- Never mix kerosene or used engine oil with the diesel fuel.
- Never keep fuel in containers with zinc plating on the inside.
- Do not use fuel additives.

Petroleum Diesel

Cetane rating: 45 or higher

Sulfur content: Ultra-low sulfur (<15 ppm)

Fuel Table

| Diesel fuel specification | Location |
|---|----------------|
| ASTM D975 No. 1-D S15 No. 2-D S15 | USA |
| EN 590 | European Union |
| ISO 8217 DMX | International |
| JIS K2204 Grade No. 2 | Japan |
| KSM-2610 | Korea |

- Use only clean, fresh diesel fuel or biodiesel fuels.
- Purchase fuel in quantities that can be used within 180 days to ensure fuel freshness.

Use summer-grade diesel fuel (No. 2-D) at temperatures above -7°C (20°F) and winter-grade fuel (No. 1-D or No. 1-D/2-D blend) below that temperature.

Note: Use of winter-grade fuel at lower temperatures provides lower flash point and cold flow characteristics which eases starting and reduces fuel filter plugging. Using summer-grade fuel above -7°C (20°F) contributes toward longer fuel pump life and increased power compared to winter-grade fuel.

Biodiesel

This machine can also use a biodiesel blended fuel of up to B20 (20% biodiesel, 80% petroleum diesel).

Sulfur content: Ultra-low sulfur (<15 ppm)

Biodiesel fuel specification: ASTM D6751 or EN14214

Blended fuel specification: ASTM D975, EN590, or JIS K2204

Important: The petroleum diesel portion must be ultra-low sulfur.

Observe the following precautions:

- Biodiesel blends may damage painted surfaces.
- Use B5 (biodiesel content of 5%) or lesser blends in cold weather.
- Monitor seals, hoses, gaskets in contact with fuel as they may be degraded over time.
- Fuel filter plugging may be expected for a time after converting to biodiesel blends.
- Contact your Authorized Toro Distributor if you wish for more information on biodiesel.

Fuel Tank Capacity

79 L (21 US gallons)

Adding Fuel

1. Park the machine on a level surface.
2. Using a clean rag, clean area around fuel tank cap.
3. Remove cap from the fuel tank (Figure 13).

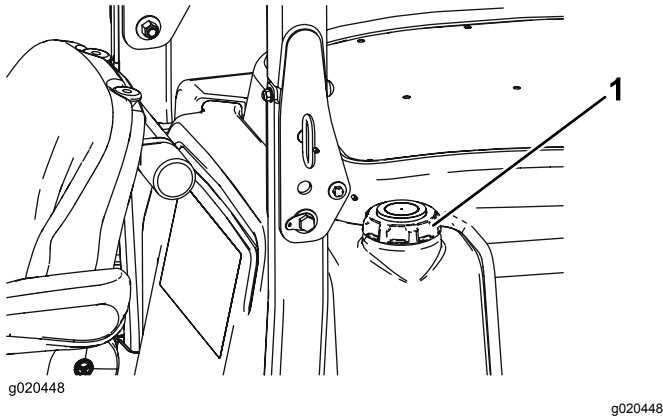

Figure 13

1. Fuel tank cap

4. Fill the tank until the level is to the bottom of the filler neck with diesel fuel.
5. Install fuel tank cap tightly after filling tank.

Note: If possible, fill the fuel tank after each use. This will minimize possible buildup of condensation inside the fuel tank.

Checking the Hydraulic Fluid

Service Interval: Before each use or daily

The machine's reservoir is filled at the factory with approximately 29.3 liters (7.75 U.S. gallons) of high quality hydraulic fluid. **Check the level of the hydraulic fluid before the engine is first started and daily thereafter.** The recommended replacement fluid is:

Toro Premium All Season Hydraulic Fluid

(Available in 18.9 liter (5 gallon) pails or 208 liter (55 gallon) drums. See parts catalog or Toro distributor for part numbers.)

Alternate fluids: If the Toro fluid is not available, other fluids may be used provided they meet all the following material properties and industry specifications. We do not recommend the use of synthetic fluid. Consult with your lubricant distributor to identify a satisfactory product.

Note: Toro will not assume responsibility for damage caused by improper substitutions, so use only products from reputable manufacturers who will stand behind their recommendation.

High Viscosity Index/Low Pour Point Anti-wear Hydraulic Fluid, ISO VG 46

Material Properties:

Viscosity, ASTM D445

St @ 40° C 44 to 50

St @ 100° C 7.9 to 8.5

Viscosity Index ASTM D2270

140 to 160

Pour Point, ASTM D97

-34° F to -49° F

Industry Specifications:

Vickers I-286-S (Quality Level), Vickers M-2950-S (Quality Level), Denison HF-0

Note: Many hydraulic fluids are almost colorless, making it difficult to spot leaks. A red dye additive for the hydraulic system oil is available in 20 ml (2/3 oz) bottles. One bottle is sufficient for 15-22 liters (4-6 gallons) of hydraulic oil. Order part no. 44-2500 from your authorized Toro distributor.

1. Position the machine on a level surface, lower the cutting units, stop the engine, and remove the key.
2. Unlatch the seat, raise it, and engage the prop rod.
3. Clean the area around the filler neck and cap of the hydraulic tank (Figure 14). Remove the cap from the filler neck.

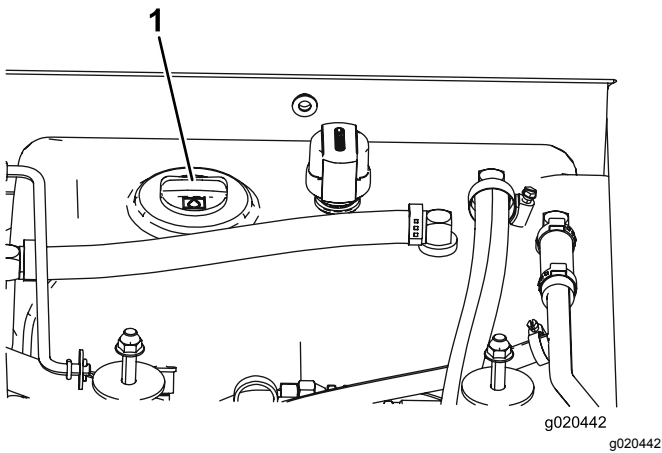

Figure 14

1. Hydraulic tank cap

4. Remove the dipstick from the filler neck and wipe it with a clean rag. Insert the dipstick into the filler neck; then remove it and check the fluid level. The fluid level should be between the two marks on the dipstick.
5. If the level is low, add oil until it is between the full and add marks mark.
6. Install the dipstick and cap onto the filler neck.

Checking the Planetary Gear Drive Oil

Service Interval: Every 400 hours

Check the oil level after every 400 hours of operation or if external leakage is noted. Use high quality SAE 85W-140 gear lube as a replacement.

1. With machine on level surface, position the wheel so one check plug (Figure 15) is at the 12 o'clock position and the other is at 3 o'clock position.

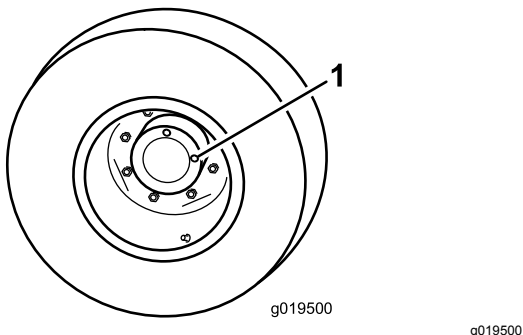

Figure 15

1. Check/drain plug (2)

2. Remove the plug at the 3 o'clock position (Figure 15). Oil level should be at the bottom of the check plug hole.

3. If the oil level is low, remove the plug at the 12 o'clock position and add oil until it begins to flow out of the hole at the 3 o'clock position.
4. Re-install both plugs.

Checking the Rear Axle Lubricant

Service Interval: Every 400 hours

The rear axle is filled with SAE 85W-140 gear lube. Check the oil level before the engine is first started and every 400 hours thereafter. The capacity is 2.4 liters (80 oz.). Visually inspect for leaks daily.

1. Position the machine on a level surface.
2. Remove a check plug from one end of the axle (Figure 16) and make sure that the lubricant is up to the bottom of the hole. If the level is low, remove the fill plug (Figure 16) and add enough lubricant to bring the level up to the bottom of the check plug holes.

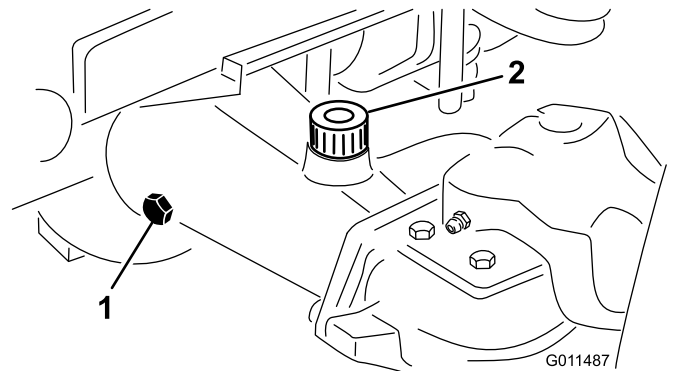

Figure 16

1. Check plug
2. Fill plug

Checking the Rear Axle Gear Box Lubricant

Service Interval: Every 400 hours

The gear box is filled with SAE 85W-140 gear lube. Check the oil level before the engine is first started and every 400 hours thereafter. The capacity is 0.5 liter (16 oz.). Visually inspect for leaks daily.

1. Position the machine on a level surface.
2. Remove the check/fill plug from the left side of the gear box (Figure 17) and make sure that lubricant is up to the bottom of the hole. If the level is low, add enough lubricant to bring the level up to the bottom of the hole.

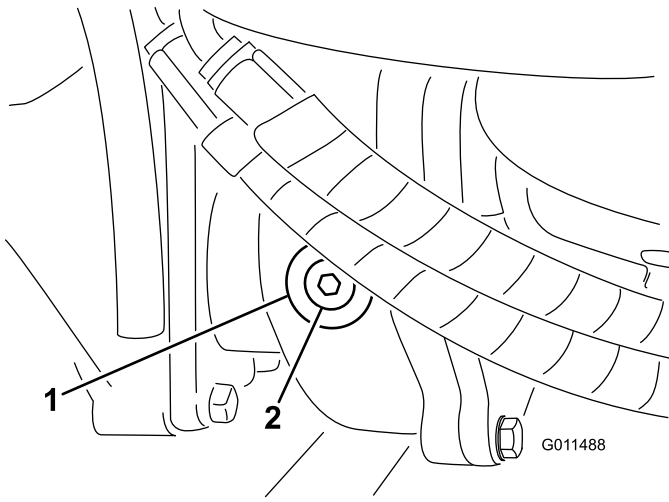

Figure 17

- 1. Gear box
- 2. Check/fill plug

Adjusting the Height-of-Cut

Center Cutting Unit

The height-of-cut is adjustable from 25 to 127 mm (1 to 5 inches) in 13 mm (1/2 inch) increments. To adjust the height-of-cut on the front cutting unit, position the castor wheel axles in the upper or lower holes of the castor forks, add or remove an equal number of spacers from the castor forks, and secure the rear chain to the desired hole.

1. Start the engine and raise the cutting units so that the height-of-cut can be changed. Stop the engine and remove the key after the cutting unit is raised.
2. Position the castor wheel axles in the same holes in all castor forks. Refer to the following chart to determine the correct holes for the setting.

Checking the Tire Pressure

Service Interval: Before each use or daily

The tires are over-inflated for shipping. Therefore, release some of the air to reduce the pressure. The correct air pressure in the front and rear tires is 172-207 kPa (25-30 psi).

Important: Maintain even pressure in all tires to ensure a good quality-of-cut and proper machine performance. Also, the Automatic Traction Assist will not work properly with improper tire pressure. **Do not under-inflate.** Replace worn or damaged tires with genuine Toro tires that are correctly sized for this machine.

Checking the Torque of the Wheel Nuts or Bolts

Service Interval: After the first 10 hours

Every 200 hours

⚠ WARNING

Failure to maintain proper torque of the wheel nuts could result in failure or loss of wheel and may result in personal injury.

Torque the front wheel nuts and rear bolts to 115 to 136 N·m (85 to 100 ft.-lb.) after 1-4 hours of operation and again after 10 hours of operation. Torque every 200 hours thereafter.

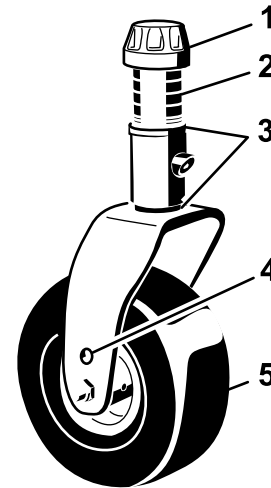

Figure 18

- 1. Tensioning cap
- 2. Spacers
- 3. Shims
- 4. Top axle mounting hole
- 5. Castor wheel

Note: When operating in 64 mm (2-1/2 inch) height of cut or higher, the axle bolt must be installed in the lower castor fork hole to prevent grass buildup between the wheel and the fork. When operating in height of cuts lower than 64 mm (2-1/2 inches) and grass buildup is detected, reverse the machines direction to pull any clippings away from the wheel/fork area.

3. Remove the tensioning cap from the spindle shaft (Figure 18) and slide the spindle out of the castor arm. Put the 2 shims (3 mm [1/8 inch]) onto the spindle shaft as they were originally installed. These shims are required to achieve a level across the entire width of the cutting units. Slide the appropriate number of 13 mm (1/2 inch) spacers (refer to the chart below) onto the

spindle shaft to get the desired height-of-cut; then slide the washer onto the shaft.

Refer to the following chart to determine the combinations of spacers for the setting:

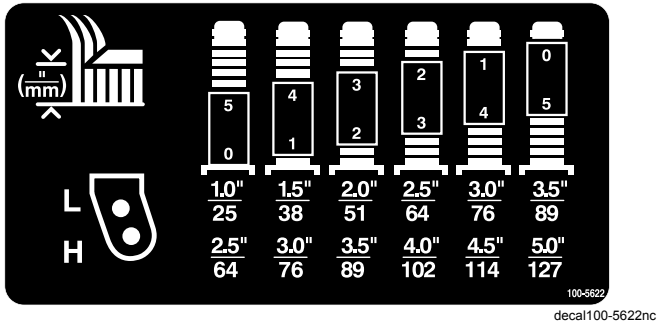

Figure 19

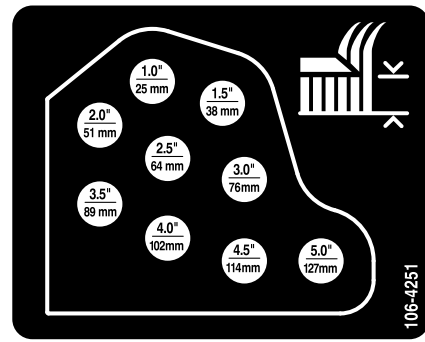

Figure 21

decal106-4251nc

Note: When using 25 mm (1 inch), 38 mm (1-1/2 inch), or occasionally 51 mm (2 inch) height-of-cut, move the skids and gage wheels to the highest position.

4. Push the castor spindle through the front castor arm. Install the shims (as they were originally installed) and the remaining spacers onto the spindle shaft. Install the tensioning cap to secure the assembly.
5. Remove the hairpin cotter and clevis pin securing the height-of-cut chains to the rear of the cutting unit (Figure 20).

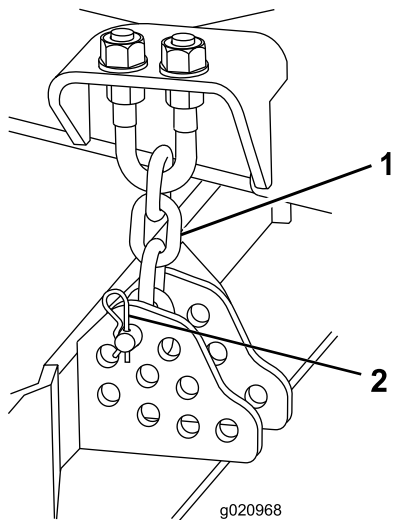

Figure 20

1. Height-of-cut chain
2. Clevis pin and hair pin cotter

6. Mount the height-of-cut chains to the desired height-of-cut hole (Figure 21) with the clevis pin and hairpin cotter.

Wing Cutting Units

To adjust the height-of-cut on the side cutting units, add or remove an equal number of spacers from the castor forks, position the castor wheel axles in the high or low height-of-cut holes in the castor forks, and secure the pivot arms to the selected height-of-cut bracket holes.

1. Position the castor wheel axles in the same holes in all of the castor forks (Figure 22 and Figure 24). Refer to the following chart to determine the correct hole for the setting.
2. Remove the tensioning cap from the spindle shaft (Figure 22) and slide the spindle out of castor arm. Put the two shims (3 mm [1/8 inch]) onto spindle shaft as they were originally installed. These shims are required to achieve a level across the entire width of the cutting units. Slide the appropriate number of 13 mm (1/2 inch) spacers onto the spindle shaft to get the desired height-of-cut; then slide the washer onto the shaft.

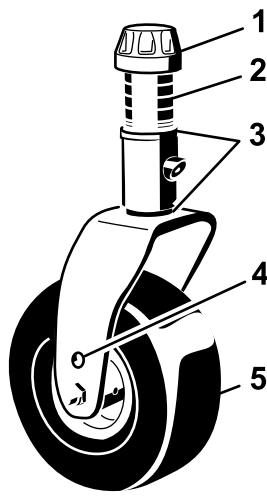

G008866

g008866

Figure 22

1. Tensioning cap
2. Spacers
3. Shims
4. To axle mounting hole
5. Castor wheel

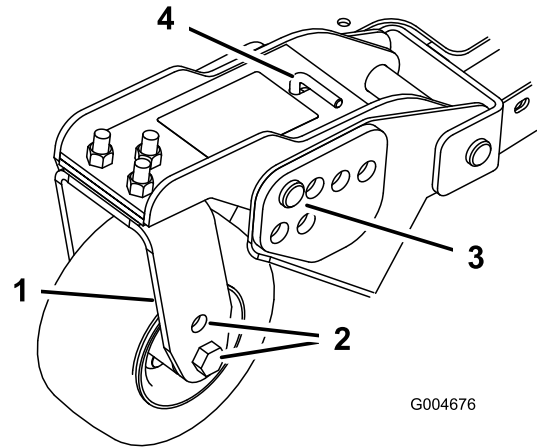

G004676

g004676

Figure 24

1. Castor pivot arm
2. Axle mounting holes
3. Clevis pin and hair pin cotter
4. Tension rod

Refer to the following chart to determine the combinations of spacers for the setting.

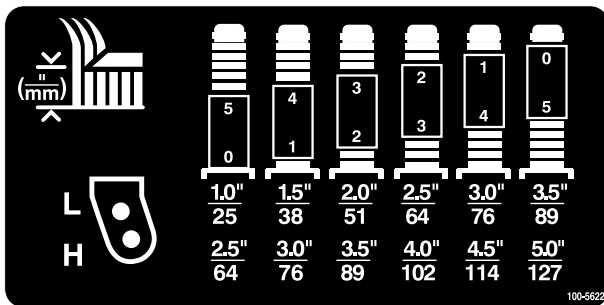

100-5622
decal100-5622nc

Figure 23

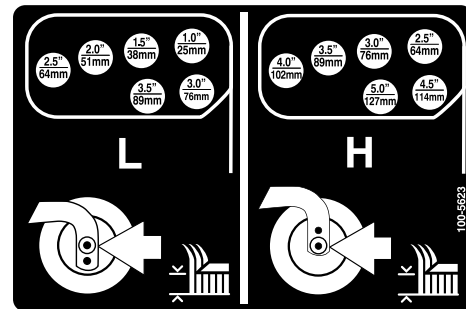

100-5623
decal100-5623nc

Figure 25

3. Push the castor spindle through the castor arm. Install the shims (as originally installed) and the remaining spacers onto the spindle shaft. Install the tensioning cap to secure the assembly.
4. Remove the hairpin cotter and clevis pins from the castor pivot arms (Figure 24).
5. Rotate tension rod to raise or lower pivot arm until holes are aligned with selected height-of-cut bracket holes in the cutting unit frame (Figure 24 and Figure 25).
6. Insert the clevis pins and install the hairpin cotters.
7. Rotate tension rod counterclockwise (finger tight) to put tension on adjustment.

Adjusting the Skids

The skids should be mounted in the lower position when operating at heights of cut greater than 64 mm (2-1/2 inches) and in the higher position when operating at heights of cut lower than 64 mm (2-1/2 inches).

Adjust the skids by removing the flange bolt and nuts, positioning them as desired, and installing the fasteners (Figure 24).

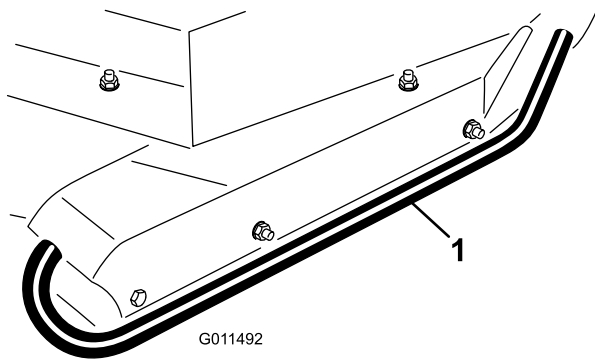

Figure 26

1. Skid

Adjusting the Cutting Unit Rollers

The cutting unit rollers should be mounted in the lower position when operating in height of cuts greater than 64 mm (2-1/2 inches) and in the higher position when operating in height of cuts lower than 64 mm (2-1/2 inches).

1. Remove the bolt and nut securing the gage wheel to the cutting unit brackets (Figure 27).

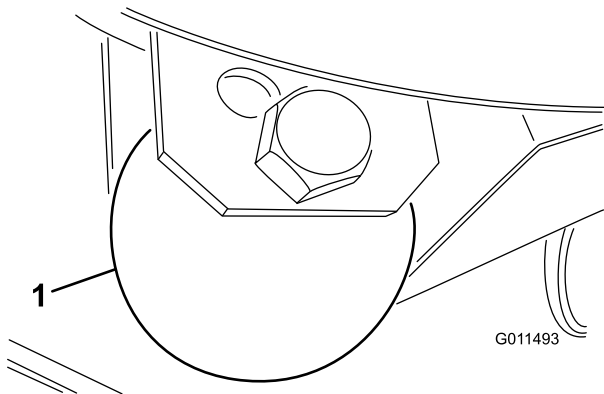

Figure 27

1. Gage wheel

2. Align the roller and spacer with the top holes in the brackets and secure them with the bolt and nut.

Adjusting the Blade

To ensure proper operation of the cutting unit, there must be 10-16 mm (0.38-0.62 inch) clearance between the tips of the wing and center cutting unit blades (Figure 28).

1. Raise cutting unit so blades are visible and block center deck section so it cannot fall accidentally. Wing decks must be horizontal to center cutting unit.

2. Rotate a center and adjoining wing blade so there blade tips are aligned. Measure distance between blade tips, distance should be approximately 10-16 mm (0.38-0.62 inch) (Figure 28).

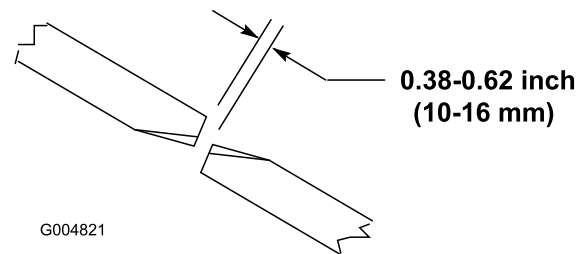

Figure 28

3. To adjust distance, locate adjuster bolt on rear pivot link of cutting unit (Figure 29). Loosen jam nut on adjuster bolt. Loosen or tighten adjuster bolts until 0.38-0.62 inch (10-16 mm) clearance is attained, then tighten jam nut.
4. Repeat procedure on opposite side of cutting deck.

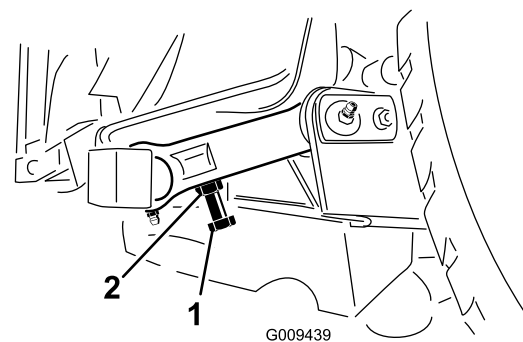

Figure 29

1. Adjuster bolt
2. Jam nut

Correcting Mismatch Between Cutting Units

Due to differences in grass conditions and the counterbalance setting of the traction unit, it is advised that a sample area of grass be cut and the appearance checked before formal cutting is started.

1. Set all cutting units to the desired height of cut; refer to Adjusting the Height of Cut.
2. Check and adjust front and rear tractor tire pressure to 172-207 kPa (25-30 psi).
3. Check and adjust all castor tire pressures to 345 kPa (50 psi).
4. Check charge and counterbalance pressures with engine at high idle using test ports defined in Hydraulic Systems Test Ports. Adjust counterbalance to 2241 kPa (325 psi).

5. Check for bent blades; refer to Checking for a Bent Blade.
6. Cut grass in a test area to determine if all cutting units are cutting at the same height.
7. If cutting unit adjustments are still needed, find a flat surface using a 2 m (6 foot) or longer straight edge.
8. To ease measuring blade plane, raise the height of cut to 7.6 to 10.1 cm (3 to 4 inches); refer to Adjusting the Height of Cut.
9. Lower cutting units onto the flat surface. Remove the covers from the top of the cutting units.
10. Loosen the flange nut, securing the idler pulley, to release the belt tension on each cutting unit.

Front Cutting Unit Setup

Rotate blade on each spindle until the ends face forward and backward. Measure from the floor to the front tip of the cutting edge. Adjust 3 mm (1/8 inch) shims on front castor fork(s) to match height of cut to decal (Figure 30); refer to Adjusting the Cutting Unit Pitch.

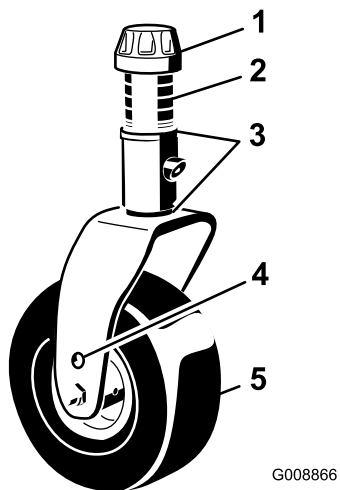

Figure 30

- | | |
|-------------------|---------------------------|
| 1. Tensioning cap | 4. Top axle mounting hole |
| 2. Spacers | 5. Castor wheel |
| 3. Shims | |

Side Cutting Unit Setup

Rotate blade of each spindle until the ends face forward and backward. Measure from the floor to the front tip of the cutting edge. Adjust 3 mm (1/8 inch) shims on front castor arm(s) to match height of cut to decal (Figure 31). For the outside blade spindle only, refer to Adjusting the Cutting Unit Pitch.

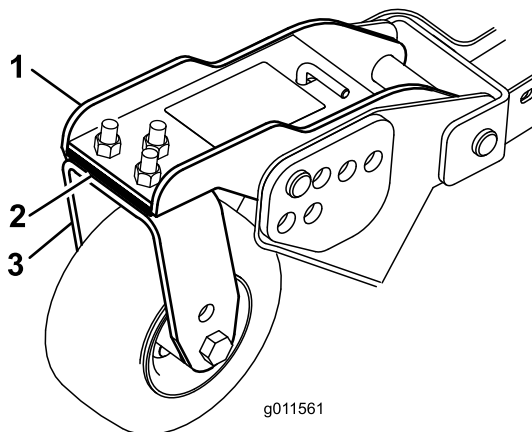

Figure 31

- | | |
|---------------------|----------------------|
| 1. Front castor arm | 3. Front castor fork |
| 2. Shims | |

Matching Height Of Cut Between Cutting Units

1. Position blade side to side on outside spindle of both side cutting units. Measure from the floor to the tip of the cutting edge on both units and compare. These numbers should be within 3 mm (1/8 inch) of each other.
2. Add or remove 1/8 inch shims as needed on wing castor wheels. Recheck measurement between outside edges of both wing cutting units and adjust as necessary

Adjusting the Mirrors

Cab model only

Rear View Mirror

While sitting in the seat, adjust the rear view mirror (Figure 32) to attain the best view out the rear window. Pull the lever rearward to tilt the mirror to reduce the brightness and glare of light.

Side View Mirrors

While sitting in the seat, have a helper adjust the side view mirrors (Figure 32) to attain the best view around the side of the machine.

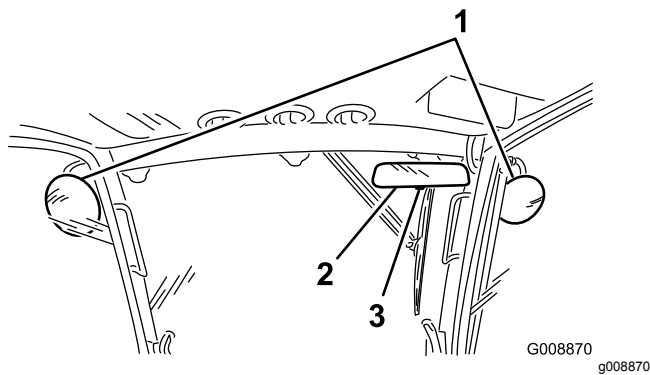

Figure 32

- | | |
|----------------------|----------|
| 1. Side view mirrors | 3. Lever |
| 2. Rear view mirror | |

starter failure may result. If the engine fails to start after 30 seconds, turn the key to the Off position, recheck the controls and procedures, wait 30 additional seconds, and repeat the starting procedure.

- To stop the engine, move the PTO switch to the Off position, set the parking brake, return the throttle setting to low idle and rotate the ignition key to Off. Remove the key from the switch to prevent accidental starting.

Important: Allow engine to idle for 5 minutes before shutting it off after a full load operation. Failure to do so may lead to turbo-charger trouble.

Aiming the Headlights

- Loosen the mounting nuts and position each headlight so that it points straight ahead. Tighten the mounting nut just enough to hold the headlight in position.
- Place a flat piece of sheet metal over the face of the headlight.
- Mount a magnetic protractor onto the plate. While holding the assembly in place, carefully tilt the headlight downward 3 degrees, then tighten the nut.
- Repeat the procedure on the other headlight.

Starting and Stopping the Engine

Important: The fuel system will automatically bleed itself when any of the following situations occur:

- Initial start up of a new machine.
- The engine has ceased running due to lack of fuel.
- Maintenance has been performed upon the fuel system components.

- Ensure that the parking brake is set. Remove your foot from the traction pedal and ensure that it is in neutral.
- Turn the ignition key to the Run position.
- When the glow indicator dims, turn the ignition key to the Start position. Release the key immediately when the engine starts and allow it to return to the Run position. Allow engine to warm up at mid speed (without load), then move the throttle control to the desired position.

Important: Do not run the starter motor more than 30 seconds at a time or premature

Cutting Grass with the Machine

Note: Cutting grass at a rate that loads the engine promotes DPF regeneration.

- Move the machine to the job site.
- Whenever possible, set the engine-speed switch to high idle.
- Engage the PTO switch.
- Gradually move the traction pedal forward and slowly drive the machine over the mowing area.
- Once the front of the cutting units are over the mowing area, lower the cutting units.
- Cut grass so that the blades can cut and discharge clippings at a high rate while producing a good quality of cut.

Note: If the cutting rate is too high, the quality of cut may deteriorate. Reduce the ground speed of the machine or reduce the width of cut to regain high idle engine speed.

- When the cutting units are over the far edge of the mowing area, lift the cutting units.
- Perform a tear-shaped turn to quickly line up for your next pass.

Diesel Particulate Filter Regeneration

The diesel particulate filter (DPF) is part of the exhaust system. The diesel-oxidation catalyst of the DPF reduces harmful gasses and the soot filter removes soot from the engine exhaust.

The DPF regeneration process uses heat from the engine exhaust to incinerate the soot accumulated on the soot filter, converting the soot to ash, and clears the channels of the soot filter so that filtered engine exhaust flows out the DPF.

The engine computer monitors the accumulation of soot by measuring the back pressure in the DPF. If the back pressure is too high, soot is not incinerating in the soot filter through normal engine operation. To keep the DPF clear of soot, remember the following:

- Passive regeneration occurs continuously while the engine is running—run the engine at full engine speed when possible to promote DPF regeneration.
- If the back pressure is too high, the engine computer signals you through the InfoCenter when additional processes (assist and reset regeneration) are running.
- Allow the assist and reset regeneration process to complete before shutting off the engine.

Operate and maintain your machine with the function of the DPF in mind. Engine load at high idle engine speed generally produce adequate exhaust temperature for DPF regeneration.

Engine Warning Messages—Soot Accumulation

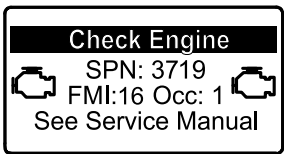
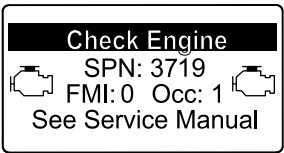
| Indication Level | Fault Code | Engine Power Rating | Recommended Action |
|-------------------------|---|---|---|
| Level 1: Engine Warning |  <p>Figure 33 Check Engine SPN 3719, FMI 16</p> | The computer de-rates the engine power to 85% | Perform a parked regeneration as soon as possible; refer to Parked Regeneration (page 39) . |
| Level 2: Engine Warning |  <p>Figure 34 Check Engine SPN 3719, FMI 0</p> | The computer de-rates the engine power to 50% | Perform a recovery regeneration as soon as possible; refer to Recovery Regeneration (page 42) . |

Important: Minimize the amount of time that you idle the engine or operate the engine at low-engine speed to help reduce the accumulation of soot in the soot filter.

⚠ CAUTION

The exhaust temperature is hot (approximately 600°C (1112°F) during DPF parked regeneration or recovery regeneration. Hot exhaust gas can harm you or other people.

- Never operate the engine in an enclosed area.
- Make sure that there are no flammable materials around the exhaust system.
- Never touch a hot exhaust system component.
- Never stand near or around the exhaust pipe of the machine.



DPF Soot Accumulation

- Over time, the DPF accumulates soot in the soot filter. The computer for the engine monitors the soot level in the DPF.
- When enough soot accumulates, the computer informs you that it is time to regenerate the diesel particulate filter.
- DPF regeneration is a process that heats the DPF to convert the soot to ash.
- In addition to the warning messages, the computer reduces the power produced by the engine at different soot-accumulation levels.

DPF Ash Accumulation

- The lighter ash is discharged through the exhaust system; the heavier ash collects in the soot filter.
- Ash is a residue of the regeneration process. Over time, the diesel particulate filter accumulates ash that does not discharge with the engine exhaust.
- The computer for the engine calculates the amount of ash accumulated in the DPF.
- When enough ash accumulates, the engine computer sends information to the InfoCenter in the form of a system advisory or an engine fault to indicate the accumulation of ash in the DPF.
- The advisory and faults are indications that it is time to service the DPF.
- In addition to the warnings, the computer reduces the power produced by the engine at different ash-accumulation levels.

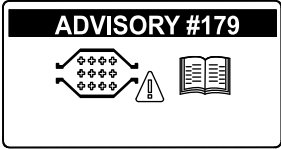
InfoCenter Advisory and Engine Warning Messages—Ash Accumulation

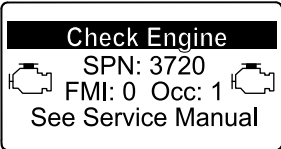
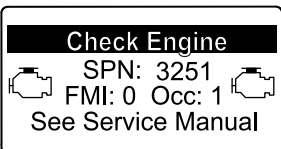
| Indication Level | Advisory or Fault Code | Engine Speed Reduction | Engine Power Rating | Recommended Action |
|-----------------------------|--|--------------------------------------|---|---|
| Level 1: System Advisory |  <p style="text-align: center;">g213865 Figure 35 Advisory #179</p> | None | 100% | Notify your service department that advisory #179 displays in the InfoCenter. |
| Level 2: Engine Warning |  <p style="text-align: center;">g213863 Figure 36 Check Engine SPN 3720, FMI 16</p> | None | The computer de-rates the engine power to 85% | Service the DPF; refer to Servicing the Diesel-Oxidation Catalyst (DOC) and the Soot Filter (page 54) |
| Level 3: Engine Warning |  <p style="text-align: center;">g213864 Figure 37 Check Engine SPN 3720, FMI 0</p> | None | The computer de-rates the engine power to 50% | Service the DPF; refer to Servicing the Diesel-Oxidation Catalyst (DOC) and the Soot Filter (page 54) |
| Level 4: Engine Warning |  <p style="text-align: center;">g214715 Figure 38 Check Engine SPN 3251, FMI 0</p> | Engine speed at max torque + 200 rpm | The computer de-rates the engine power to 50% | Service the DPF; refer to Servicing the Diesel-Oxidation Catalyst (DOC) and the Soot Filter (page 54) |

Types of Diesel Particulate Filter Regeneration

Types of diesel particulate filter regeneration that are performed while the machine is operating:

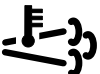
| Type of Regeneration | Conditions for DPF regeneration | DPF description of operation |
|----------------------|---|---|
| Passive | Occurs during normal operation of the machine at high-engine speed or high-engine load | <p>The InfoCenter does not display an icon indicating passive regeneration.</p> <p>During passive regeneration, the DPF processes high-heat exhaust gasses; oxidizing harmful emissions and burning soot to ash.</p> <p>Refer to Passive DPF Regeneration (page 38).</p> |
| Assist | Occurs as a result of low-engine speed, low-engine load, or after the computer detects back pressure in the DPF | <p>When the assist/reset-regeneration icon  is displayed in the InfoCenter, an assist regeneration is in progress.</p> <p>During assist regeneration, the computer controls the intake throttle to increase the exhaust temperature, enabling assist regeneration to occur.</p> <p>Refer to Assist DPF Regeneration (page 38).</p> |
| Reset | <p>Occurs after assist regeneration only if the computer detects that assist regeneration did not sufficiently reduce the soot level</p> <p>Also occurs every 100 hours to reset baseline sensor readings</p> | <p>When the assist/reset-regeneration icon  is displayed in the InfoCenter, a regeneration is in progress.</p> <p>During reset regeneration, the computer controls the intake throttle and fuel injectors to increase the exhaust temperature during regeneration.</p> <p>Refer to Reset Regeneration (page 39).</p> |

Types of diesel particulate filter regeneration that require you to park the machine:

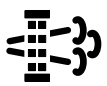
| Type of Regeneration | Conditions for DPF regeneration | DPF description of operation |
|----------------------|--|---|
| Parked | <p>Soot buildup occurs as a result of prolonged operation at low-engine speed or low-engine load. May also occur as a result of using incorrect fuel or oil</p> <p>The computer detects back pressure due to soot buildup and requests a parked regeneration</p> | <p>When the parked-regeneration icon  is displayed in the InfoCenter, a regeneration is requested.</p> <ul style="list-style-type: none"> • Perform the parked regeneration as soon as possible to avoid needing a recovery regeneration. • A parked regeneration requires 30 to 60 minutes to complete. • You must have at least a 1/4 tank of fuel in the tank. • You must park the machine to perform a recovery regeneration. <p>Refer to Parked Regeneration (page 39).</p> |

Types of diesel particulate filter regeneration that require you to park the machine: (cont'd.)

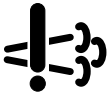
| Type of Regeneration | Conditions for DPF regeneration | DPF description of operation |
|----------------------|---|---|
| Recovery | Occurs as a result of ignoring parked regeneration requests and continuing operation, adding more soot when the DPF is already in need of a parked regeneration |  <p>When the recovery-regeneration icon is displayed in the InfoCenter, a recovery regeneration is requested.</p> <p>Contact your Authorized Toro Distributor to have a service technician perform the recovery regeneration.</p> <ul style="list-style-type: none"> • A recovery regeneration requires up to 4 hours to complete. • You must have at least a 1/2 tank of fuel in the machine. • You must park the machine to perform a recovery regeneration. <p>Refer to Recovery Regeneration (page 42).</p> |

Passive DPF Regeneration

- Passive regeneration occurs as part of normal engine operation.
- While operating the machine, run the engine at full-engine speed when possible to promote DPF regeneration.

- While operating the machine, run the engine at full engine speed when possible to promote DPF regeneration.

Assist DPF Regeneration

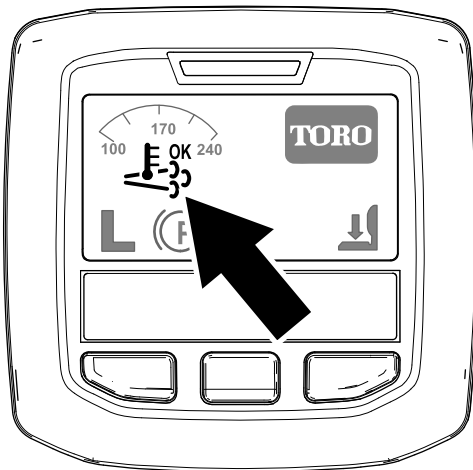



Figure 39

Assist/reset-regeneration icon

- The  icon displays in the InfoCenter while the assist regeneration is processing.
- Whenever possible, do not shut off the engine or reduce engine speed while the assist regeneration is processing.

Important: Allow the machine to complete the assist regeneration process before shutting off the engine.

Note: The assist regeneration is finished

processing when the  icon disappears from the InfoCenter.

- The assist/reset-regeneration icon displays in the InfoCenter ([Figure 39](#)).
- The computer takes control of the intake throttle to increase the temperature of the engine exhaust.

Reset Regeneration

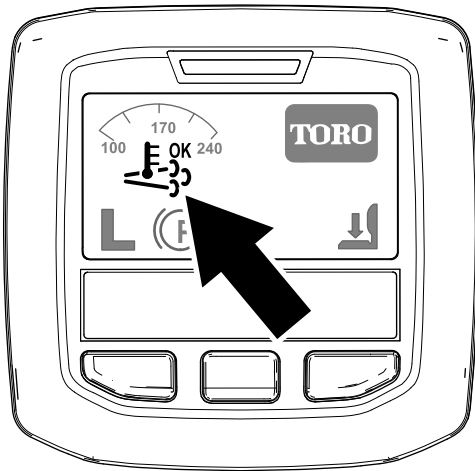

g214711

Figure 40

Assist/reset-regeneration icon

Parked Regeneration

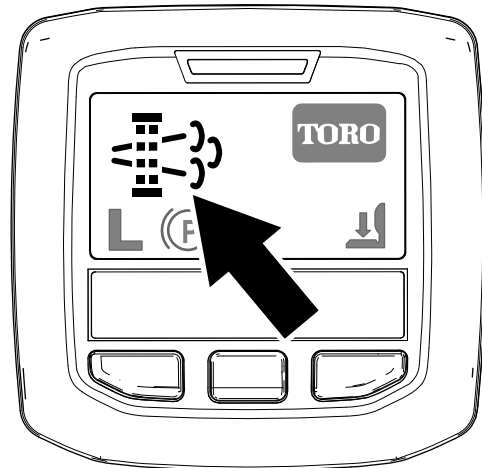

g214713

Figure 41

Parked-regeneration request icon

- The assist/reset-regeneration icon displays in the InfoCenter (Figure 40).
- The computer takes control of the intake throttle and changes the fuel injection operation to increase the temperature of the engine exhaust.

Important: The assist/reset-regeneration icon indicates that the exhaust temperature discharged from of your machine may be hotter than during regular operation.

- While operating the machine, run the engine at full engine speed when possible to promote DPF regeneration.

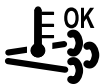

- The  icon displays in the InfoCenter while the reset regeneration is processing.
- Whenever possible, do not shut off the engine or reduce engine speed while the reset regeneration is processing.

Important: Allow the machine to complete the reset regeneration process before shutting off the engine.

Note: The reset regeneration is finished

processing when the  icon disappears from the InfoCenter.

- The parked-regeneration requested icon displays in the InfoCenter (Figure 41).
- If a parked regeneration is needed, the InfoCenter displays engine warning SPN 3719, FMI 16 (Figure 42) and the engine computer derates engine power to 85%.

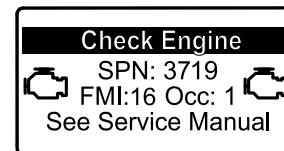

g213866

Figure 42

Important: If you do not complete a parked regeneration within 2 hours, the engine computer derates engine power to 50%.

- A parked regeneration requires 30 to 60 minutes to complete.
- If you are authorized by your company, you need the PIN code to perform the parked-regeneration process.

Preparing to Perform a Parked or Recovery Regeneration

1. Ensure that the machine has at least 1/4 tank of fuel.
2. Move the machine outside to an area away from combustible materials.
3. Park the machine on a level surface.
4. Ensure that the traction control or motion-control levers are in the NEUTRAL position.
5. If applicable, lower the cutting units and shut them off.

6. Engage the parking brake.
7. Set the throttle to the low IDLE position.

Performing a Parked Regeneration

Note: For instructions on unlocking protected menus, refer to [Accessing Protected Menus \(page 22\)](#).

1. Access the protected menu and unlock the protected settings submenu ([Figure 43](#)); refer to [Accessing Protected Menus \(page 22\)](#).

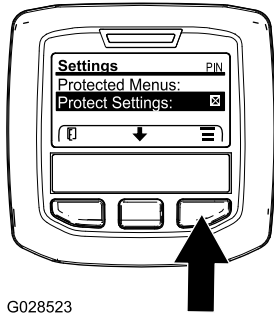

G028523

Figure 43

g028523

2. Navigate to the MAIN MENU, press the center button to scroll down to the SERVICE MENU, and press the right button to select the SERVICE option ([Figure 44](#)).

Note: The InfoCenter should display the PIN indicator in the upper right corner of the display.

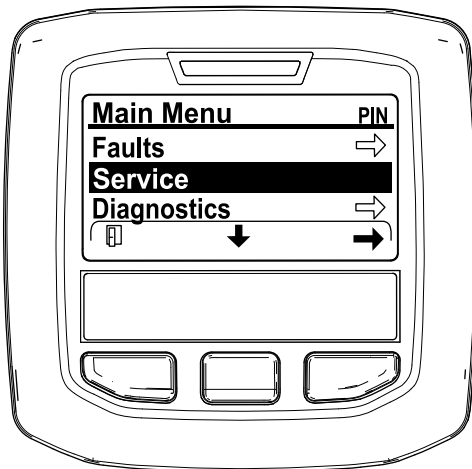

Figure 44

g212371

3. In the SERVICE MENU, press the middle button until the DPF REGENERATION options displays, and press the right button to select the DPF REGENERATION option ([Figure 45](#)).

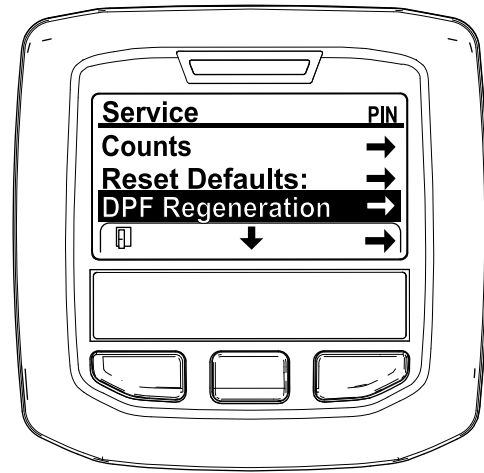

Figure 45

g212138

4. When the "Initiate DPF Regen. Are you sure?" message displays, press the center button ([Figure 46](#)).

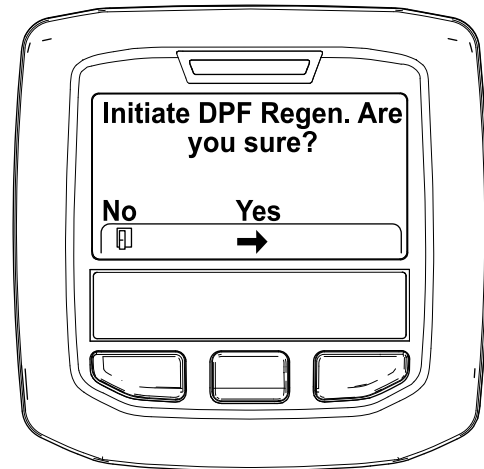



Figure 46

g212125

5. If the coolant temperature is below 60°C (140°F) the "Insure  is running and above 60C/140F" message displays. ([Figure 47](#)).

Observe the temperature in the display, and run the machine at full throttle until the temperature reaches 60°C (140°F), then press the center button.

Note: If the coolant temperature is above 60°C (140°F) this screen is skipped.

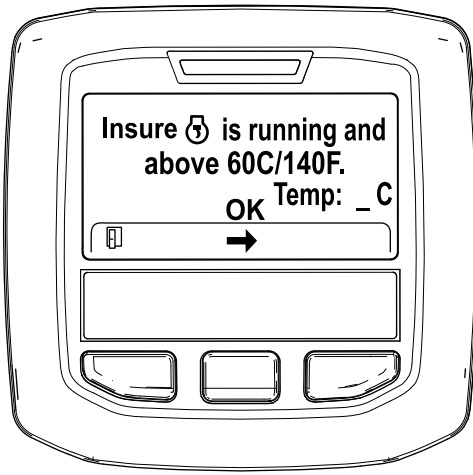

Figure 47

g211986

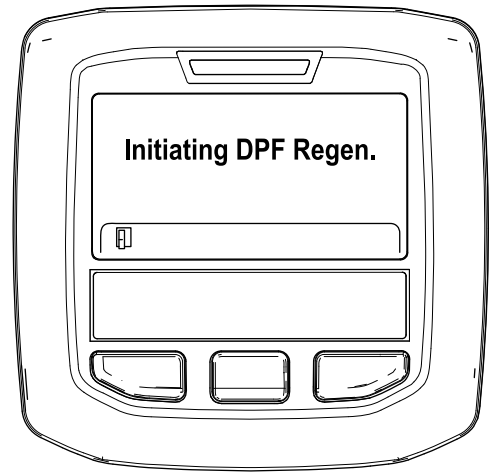

Figure 49

g212405

6. Move the throttle control to LOW IDLE and press the center button (Figure 48).

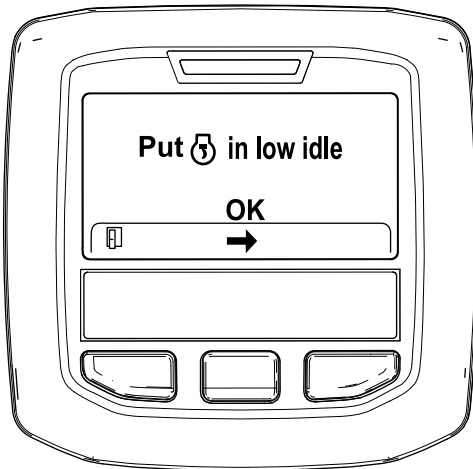

Figure 48

g212372

- B. The "Waiting on [engine icon]" message displays (Figure 50).



Figure 50

g212406

7. The following messages display as the parked regeneration process begins:

- A. The "Initiating DPF Regen." message displays (Figure 49).

- C. The computer determines whether the regeneration runs. One of the following messages displays in the InfoCenter:
- If the regeneration is allowed, the "Regen Initiated. Allow up to 30 minutes for completion" message displays in the InfoCenter, wait for the machine to complete the parked regeneration process (Figure 51).

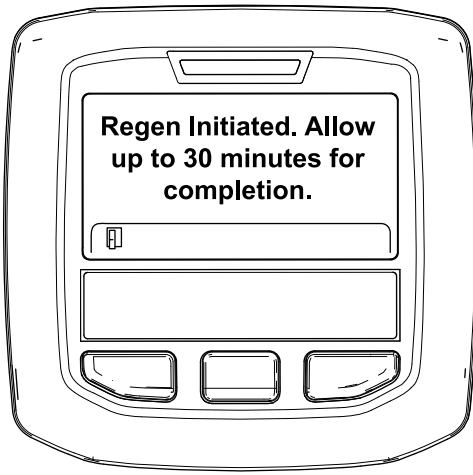
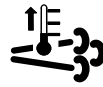

Figure 51

g213424



The engine is cold—wait.



The engine is warm—wait.

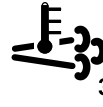

30%

The engine hot—regeneration in progress (percent complete).

9. The parked regeneration is complete when the “Regen Complete” message displays in the InfoCenter. Press the left button to exit to the home screen (Figure 53).

- If the regeneration process is not allowed by the engine computer, the “DPF Regen Not Allowed” message displays in the InfoCenter (Figure 52). Press the left button to exit to the home screen

Important: If you did not meet all the requirements for regeneration or if less than 50 hours have passed since the last regeneration, the “DPF Regen Not Allowed” message appears.

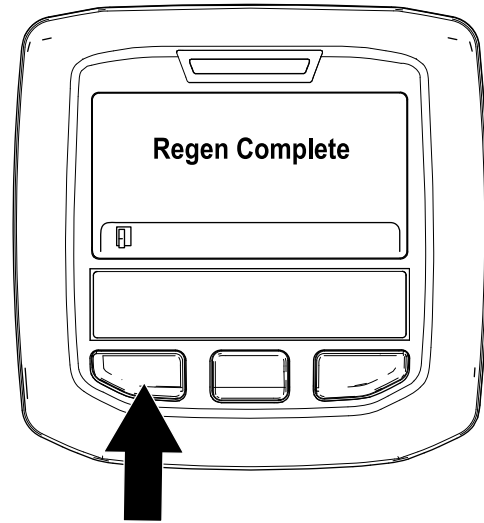

Figure 53

g212404

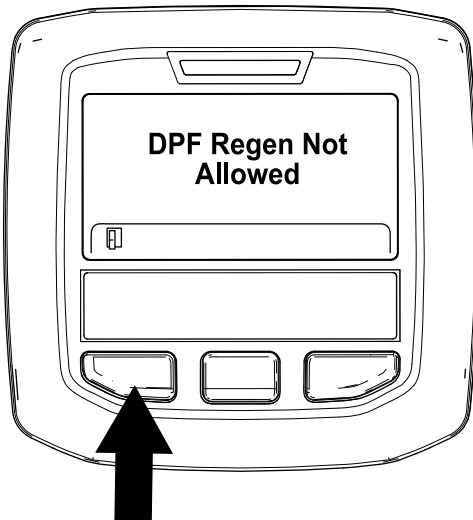

Figure 52

g212410

8. While the regeneration is running, the InfoCenter returns to the home screen and shows the following icons:

Recovery Regeneration

- If you ignore the request for a parked regeneration (displayed in the InfoCenter) and continue to operate the machine, a critical amount of soot builds up in the DPF.
- If a recovery regeneration is needed, the InfoCenter displays engine warning SPN 3719, FMI 16 (Figure 54) and the engine computer derates engine power to 85%.

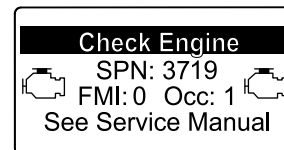

Figure 54

g213867

Important: If you do not complete a recovery regeneration within 15 minutes, the engine computer derates engine power to 50%.

- Perform a recovery-regeneration whenever there is a loss of engine power and a parked regeneration cannot effectively clean the DPF of soot.
- A recovery regeneration requires up to 4 hours to complete.
- You need a distributor technician to perform the recovery regeneration process; contact your Authorized Toro Distributor.

Smart Power

With Toro Smart Power™, the operator does not have to listen to the engine speed in heavy conditions. Smart Power prevents bogging down in heavy turf by automatically controlling the machine speed and optimizing cutting performance. The operator can simply set a max ground speed that is comfortable, and mow without having to manually reduce the traction speed when mowing in heavy conditions.

Reversing Fan Operation

The fan speed is controlled by hydraulic oil temperature and engine coolant temperature. A reverse cycle is automatically initiated when either the engine coolant or hydraulic oil temperature reaches a certain point. This reversal will help blow debris off the rear screen and lower the engine and hydraulic oil temperatures. By simultaneously pressing the right and left buttons on the InfoCenter, the fan will complete a manually initiated reverse cycle. It is recommended to manually reverse the fan prior to transporting on roads, entering the shop or a storage area.

Auto Idle

The machine is equipped with auto idle which automatically idles the engine when all of the following functions are not used, for a pre determined time, previously set in the InfoCenter.

- The traction pedal is returned to the neutral position
- The PTO is disengaged
- None of the lift switches are activated

When any of the above functions are initiated, the machine will automatically return to the previous throttle position.

Cruise Control

The cruise control switch locks in the pedal position to maintain the desired ground speed. Pressing the rear of the switch turns off the cruise control, the middle position of the switch enables the cruise control

function and the front of the switch sets the desired ground speed

Note: Pressing either brake pedal or moving the traction pedal into the reverse position, for one second, will also disengage the cruise control

Engine Speed Switch

The engine speed switch has two modes to change the engine speed. By momentarily tapping the switch, the engine speed can be increased or decreased in 100 rpm increments. By holding the switch down the engine will automatically move to High or Low idle, depending on which of the switch is depressed.

Mow Speed

Supervisor (Protected Menu)

Allows the supervisor to set the machine's maximum mowing speed, in increments of 50%, 75% or 100%, at which the operator can mow (low range).

Refer to Using the InfoCenter LCD Display, in the Operation section of this manual, for the procedure to set the mow speed.

Operator

Allows the operator to adjust the machine's maximum mowing speed (low range), within the supervisors pre-adjusted settings. When in the InfoCenter splash or main screen, press the middle button ( icon) to adjust the speed.

Note: When switching between low and high ranges, the settings will transfer based on the previous setting. The settings are reset when the machine is turned off.

Note: This feature may also be used in conjunction with cruise control.

Transport Speed

Supervisor (Protected Menu)

Allows the supervisor to set the machine's maximum transport speed, in increments of 50%, 75% or 100%, at which the operator can transport (high range).

Refer to Using the InfoCenter LCD Display, in the Operation section of this manual, for the procedure to set the transport speed.

Operator

Allows the operator to adjust the machine's maximum transport speed (high range), within the supervisors pre-adjusted settings. When in the InfoCenter splash or main screen, press the middle button ( icon) to adjust the speed.

Note: When switching between low and high ranges, the settings will transfer based on the previous setting. The settings are reset when the machine is turned off.

Note: This feature may also be used in conjunction with cruise control.

Checking the Interlock Switches

⚠ CAUTION

If safety interlock switches are disconnected or damaged the machine could operate unexpectedly causing personal injury.

- Do not tamper with the interlock switches.
- Check the operation of the interlock switches daily and replace any damaged switches before operating the machine.

The machine has interlock switches in the electrical system. These switches are designed to stop traction when the operator gets off of the seat when the traction pedal is depressed. Although the engine will continue to run, it is strongly recommended that the engine be stopped before rising from the seat.

To check the operation of the interlock switches, perform the following procedure:

1. Drive the machine slowly to a large, relatively open area. Lower the cutting unit, stop the engine, and apply the parking brake.
2. Sit on the seat and depress the traction pedal. Try to start the engine. The engine should not crank. If the engine cranks, there is a malfunction in the interlock system that should be corrected before beginning operation.
3. Sit on the seat and start the engine. Rise from the seat and move the PTO lever to On. The PTO should not engage. If the PTO engages, there is a malfunction in the interlock system that should be corrected before beginning operation.
4. Sit on the seat, engage the parking brake and start the engine. Move the traction pedal out of the neutral position. The InfoCenter will display "traction not allowed" and the machine should not move. If the engine does move, there is a malfunction in the interlock system that should be corrected before beginning operation.

Using the Rollover Protection System (ROPS)

⚠ WARNING

To avoid injury or death from rollover: keep the roll bar in the raised locked position and use the seat belt.

Ensure that the seat is secured with the seat latch.

⚠ WARNING

There is no rollover protection when the roll bar is in the down position.

- Lower the roll bar only when absolutely necessary.
- Do not wear the seat belt when the roll bar is in the down position.
- Drive slowly and carefully.
- Raise the roll bar as soon as clearance permits.
- Check carefully for overhead clearances (i.e. branches, doorways, electrical wires) before driving under any objects and do not contact them.

Important: Lower the roll bar only when absolutely necessary.

1. To lower the roll bar, remove the hairpin cotters and the two pins (Figure 55).

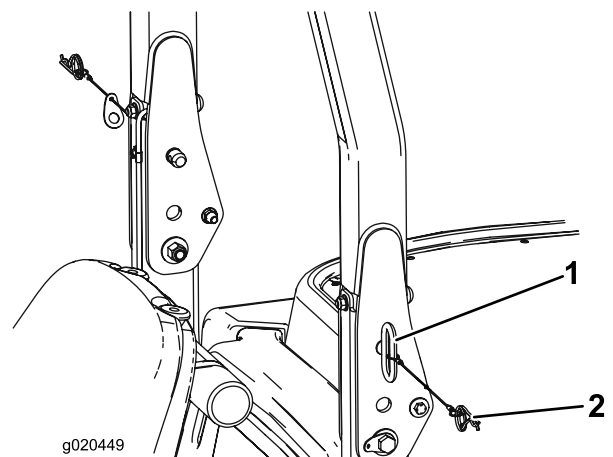

Figure 55

1. Pin (2)
2. Hair pin cotter (2)

2. Lower the roll bar to the down position.
3. Install the two pins and secure them with the hairpin cotter pins.

Important: Ensure that the seat is secured with the seat latch.

4. To raise the roll bar, remove the hairpin cotter pins and remove the two pins.
5. Raise the roll bar to the upright position and install the two pins and secure them with the hairpin cotter pins

Important: Always use the seat belt when the roll bar is in the raised and locked position. Do not use the seat belt when the roll bar is in the lowered position.

Pushing or Towing the Machine

In an emergency, the machine can be moved forward by actuating the bypass valve in the variable displacement hydraulic pump and pushing or towing the machine.

Important: Do not push or tow the machine faster than 3-4.8 km/h (2-3 MPH) because internal transmission damage may occur. The bypass valves must be open whenever the machine is pushed or towed.

1. Raise the seat. The bypass valves are located below the front of the fuel tank (Figure 56).
2. Rotate each valve 3 turns counter-clockwise to open and allow oil to bypass internally. **Do not open more than 3 turns.** Because fluid is bypassed, the machine can be slowly moved without damaging the transmission.
3. Close the bypass valves before starting the engine. Torque to 70 N-m (52 ft-lb) to close the valve.

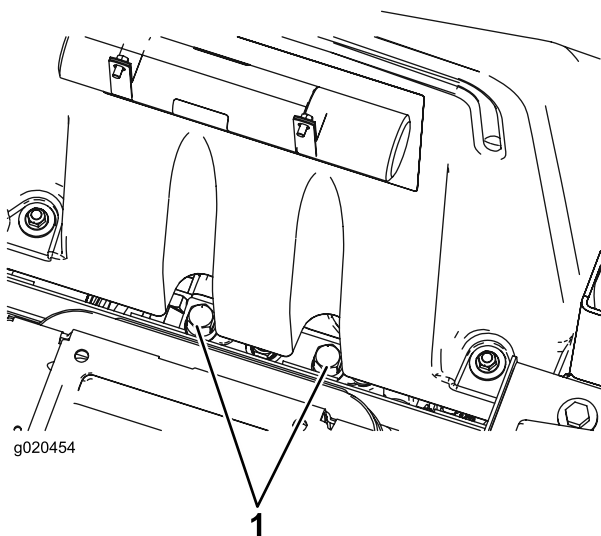

Figure 56

1. Bypass valve (2)

Important: If the machine must be pushed or towed in reverse, the check valve in the four-wheel drive manifold must also be bypassed. To bypass the check valve, connect a hose assembly (Hose Part No. 95-8843, Coupler Fitting No. 95-0985 [Qty. 2], and Hydraulic Fitting No. 340-77 [Qty. 2]) to the reverse traction pressure test port, located on the hydrostat, and on the port located in-between ports M8 and P2 on the rear traction manifold which is located behind the front tire.

Jacking Points

There are jacking points located at the front and rear of the machine.

- On the frame at the inside of each front drive tire
- At the center of the rear axle

Tie Downs

There are tie downs located at the front, rear and sides of the machine.

- Two on the front of the operator's platform
- The rear bumper

Operating Characteristics

Practice driving the machine because it has a hydrostatic transmission and its characteristics are different than many turf maintenance machines. Some points to consider when operating the traction unit, cutting unit, or other implements are the transmission, engine speed, load on the cutting blades or other implement components, and the importance of the brakes.

With Toro Smart Power™, the operator does not have to listen to the engine speed in heavy conditions. Smart Power prevents bogging down in heavy turf by automatically controlling the machine speed and optimizing cutting performance.

The brakes can be used to assist in turning the machine. However, use them carefully, especially on soft or wet grass because the turf may be torn accidentally. Another benefit of the brakes is to maintain traction. For example, in some slope conditions, the uphill wheel slips and loses traction. If this situation occurs, depress the uphill turn pedal gradually and intermittently until the uphill wheel stops slipping, thus, increasing traction on the downhill wheel.

Traction Assist is now automatic and requires no operator input. When a wheel starts to slip, flow is

automatically split between the front and rear wheels to minimize wheel slip and loss of traction.

Use extra care when operating the machine on slopes. Make sure that the seat latch is properly secured and the seat belt is buckled. Drive slowly and avoid sharp turns on slopes to prevent roll overs. For steering control, the cutting unit must be lowered when going downhill.

Before stopping the engine, disengage all controls and change the throttle to Slow. Changing the throttle to Slow reduces high engine speed, noise, and vibration. Turn the key to Off to stop the engine.

Before transporting the machine, raise the cutting units and secure the transport latches (Figure 57).

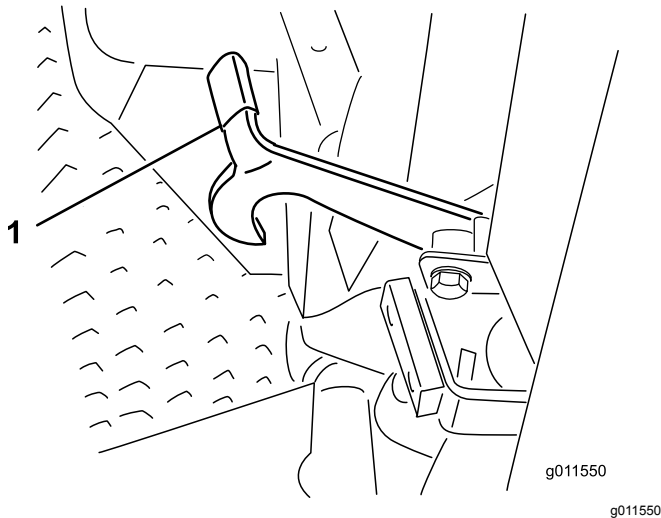

Figure 57

1. Transport latch (side cutting units)

Operating Tips

Mow When Grass is Dry

Mow either in the late morning to avoid the dew, which causes grass clumping, or in late afternoon to avoid the damage that can be caused by direct sunlight on the sensitive, freshly mowed grass.

Select the Proper Height-of-Cut Setting to Suit Conditions

Remove approximately 25 mm (1 inch) or no more than 1/3 of the grass blade when cutting. In exceptionally lush and dense grass, you may have to raise the height-of-cut to the next setting.

Mow at Proper Intervals

Under most normal conditions you will need to mow approximately every 4-5 days. But remember, grass

grows at different rates at different times. This means that in order to maintain the same height-of-cut, which is a good practice, you will need to cut more frequently in early spring; as the grass growth rate slows in mid summer, cut only every 8-10 days. If you are unable to mow for an extended period due to weather conditions or other reasons, mow first with the height-of-cut at a high level; then mow again 2-3 days later with a lower height setting.

Transporting

Use the transport latches when transporting over long distances, rough terrain, or when trailering.

After Operating

To ensure optimum performance, clean the underside of the mower housing after each use. If residue is allowed to build up in the mower housing, cutting performance will decrease.

Also, remove any debris which may have collected between the deck lift cylinders and the foam deck pads (Figure 58).

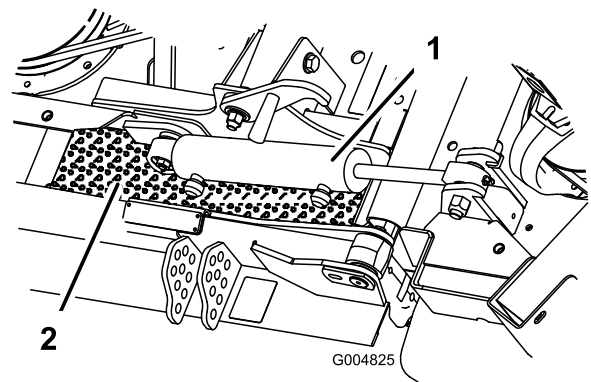

Figure 58

1. Deck lift cylinder
2. Foam deck pad

Cutting Unit Pitch

A blade pitch of 8 to 11 mm (5/16 to 7/16 inch) is recommended. A pitch larger than 8 to 11 mm (5/16 to 7/16 inch) will result in less power required, larger clippings, and a poorer quality of cut. A pitch less than 8 to 11 mm (5/16 to 7/16 inch) will result in more power required, smaller clippings and a better quality of cut.

Maximizing Air Conditioner Performance

- To limit solar heating, park the machine in a shaded area or leave the doors open in direct sun.
- Check to make sure the air conditioning condenser fins are clean.

- Operate the air conditioner blower at the mid speed setting.
- Verify continuous seal between the roof and the headliner. Correct as required.
- Measure the air temperature at the front center vent in the headliner (Typically stabilize at less than or equal to 50 degrees F.)
- Refer to the Service Manual for additional information

Maintenance

Note: Determine the left and right sides of the machine from the normal operating position.

Recommended Maintenance Schedule(s)

| Maintenance Service Interval | Maintenance Procedure |
|------------------------------|---|
| After the first 10 hours | <ul style="list-style-type: none"> • Torque the wheel lug nuts. • Check the alternator belt tension. • Check the compressor belt tension. • Check the blade drive belt tension. |
| After the first 200 hours | <ul style="list-style-type: none"> • Change the front planetary gear oil. • Change the rear axle oil. |
| Before each use or daily | <ul style="list-style-type: none"> • Check the coolant level. • Check the hydraulic fluid level. • Check the tire pressure. • Check the air cleaner indicator • Check the engine-oil level. • Drain water from water separator. • Remove all debris and chaff from the engine compartment, radiator and oil cooler. • Check the interlock switch operation |
| Every 50 hours | <ul style="list-style-type: none"> • Lubricate all grease fittings. • Inspect the air cleaner. • Check the blade drive belt tension. • Clean the air conditioning screen. (Clean more frequently in extremely dusty or dirty conditions) |
| Every 100 hours | <ul style="list-style-type: none"> • Inspect the cooling system hoses and clamps. • Check the alternator belt tension. • Check the compressor belt tension. |
| Every 200 hours | <ul style="list-style-type: none"> • Torque the wheel lug nuts. |
| Every 250 hours | <ul style="list-style-type: none"> • Change the engine oil and filter. • Clean the cab air filters. (Replace them if they are torn or excessively dirty.) • Clean the air conditioning coil. (Clean more frequently in extremely dusty or dirty conditions) |
| Every 400 hours | <ul style="list-style-type: none"> • Check the planetary gear drive oil. • Check the rear axle lubricant. • Check the rear axle gear box lubricant. • Service the air filter (if the indicator shows red). • Inspect the fuel lines and connections. • Replace the fuel filter canister. • Replace the engine fuel filter. |
| Every 800 hours | <ul style="list-style-type: none"> • Drain and clean the fuel tank. • Change the front planetary gear oil. (Or yearly, whichever comes first) • Change the rear axle oil. • Check the rear wheel toe-in. • Inspect the blade drive belts. • Change the hydraulic oil. • Change the hydraulic oil filters. • Inspect the cutting unit castor wheel assemblies. |
| Every 1,000 hours | <ul style="list-style-type: none"> • Check and adjust the engine valve clearance. |

| Maintenance Service Interval | Maintenance Procedure |
|------------------------------|---|
| Every 6,000 hours | <ul style="list-style-type: none"> Disassemble, clean, and assemble the soot filter of the DPF. or clean the soot filter if engine faults SPN 3720 FMI 16, SPN 3720 FMI 0, or SPN 3720 FMI 16 display in the InfoCenter. |
| Every 2 years | <ul style="list-style-type: none"> Flush the cooling system and replace fluid. Replace moving hoses. |

⚠ CAUTION

If you leave the key in the ignition switch, someone could accidentally start the engine and seriously injure you or other bystanders.

Remove the key from the ignition before you do any maintenance.

Service Interval Chart

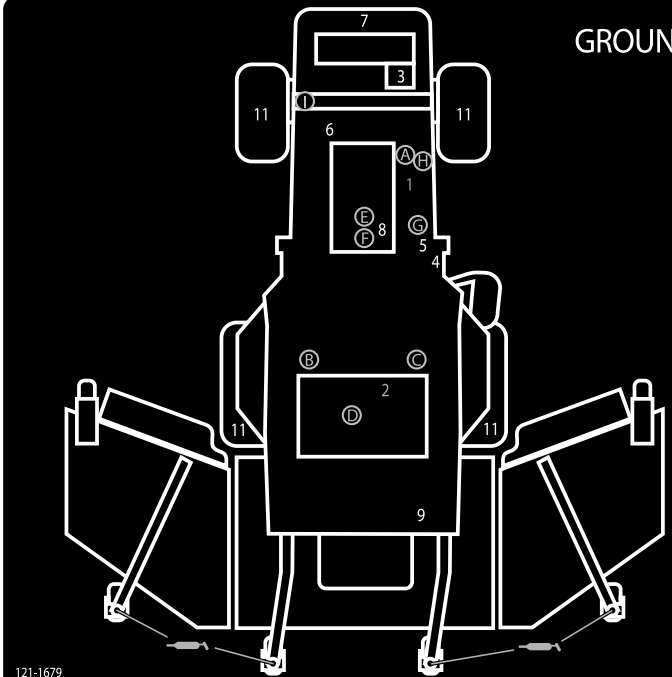

GROUNDMASTER 4100, MODELS 30606 & 30608 QUICK REFERENCE AID

1 

CHECK/SERVICE (DAILY)

1. ENGINE OIL LEVEL
2. HYDRAULIC FLUID LEVEL
3. ENGINE COOLANT LEVEL
4. FUEL - DIESEL ONLY
5. FUEL/WATER SEPARATOR
6. FAN BELT TENSION
7. RADIATOR SCREEN
8. AIR CLEANER
9. BRAKE FUNCTION
10. INTERLOCK SYSTEM
11. TIRE PRESSURE - 25 PSI/1.70 BAR
12. GREASE POINTS (4)

SEE OPERATOR'S MANUAL FOR 50 HR INTERVAL GREASE POINTS.

SPECIFICATIONS/CHANGE INTERVALS

| SEE OPERATOR'S MANUAL FOR INITIAL CHANGES. | FLUID TYPE | CAPACITY | CHANGE INTERVAL | | FILTER PART NO. | |
|--|-------------------------------|---------------------------------|----------------------------|-----------------------|----------------------------|--------------|
| | | | FLUID | FILTER | | |
| ENGINE OIL | 15W-40 CJ-4 | 6 QUARTS | 250 HOURS | 250 HOURS | 125-7025 (A) | |
| HYDRAULIC FLUID | ISO VG 46/68 | 7.75 GALLONS | 800 HOURS | 800 HOURS | 75-1310 (B) 94-2621 (C) | |
| HYDRAULIC BREATHER | | | | 800 HRS/YRLY | 115-9793 (D) | |
| PRIMARY AIR FILTER | | | | SEE SERVICE INDICATOR | 108-3814 (E) | |
| SAFETY AIR FILTER | | | | SEE OPERATOR'S MANUAL | 108-3816 (F) | |
| FUEL SYSTEM | > 32 F | NO. 2 DIESEL | 21 GALLONS | 800 HOURS DRAIN/FLUSH | 400 HOURS/YEARLY | 125-2915 (G) |
| | < 32 F | NO. 1 DIESEL | | | | 125-8752 (H) |
| REAR AXLE | 85W-140 | 80 OUNCES | 800 HOURS | | 110-4812 (I) | |
| PLANETARY DRIVE | 85W-140 | 22 OUNCES | 800 HOURS | | | |
| ENGINE COOLANT | 50% WATER 50% ETHYL GLYCOL | 9 QUARTS (14.5 QUARTS WITH CAB) | DRAIN & FLUSH EVERY 2 YRS. | | | |

Figure 59

decal121-1679

Lubrication

Greasing the Bearings and Bushings

The machine has grease fittings that must be lubricated regularly with No. 2 General Purpose Lithium Base Grease. If the machine is operated under normal conditions, lubricate all bearings and bushings after every 50 hours of operation or immediately after every washing.

The grease fitting locations and quantities are:

Traction Unit

Service Interval: Every 50 hours

- Brake pedal pivot shaft bearings (2) (Figure 60)
- Front and rear axle pivot bushings (2) (Figure 61)
- Steering cylinder ball joints (2) (Figure 62)
- Tie rod ball joints (2) (Figure 62)
- King pin bushings (2) (Figure 62).
The top fitting on the king pin should only be lubricated annually (2 pumps).

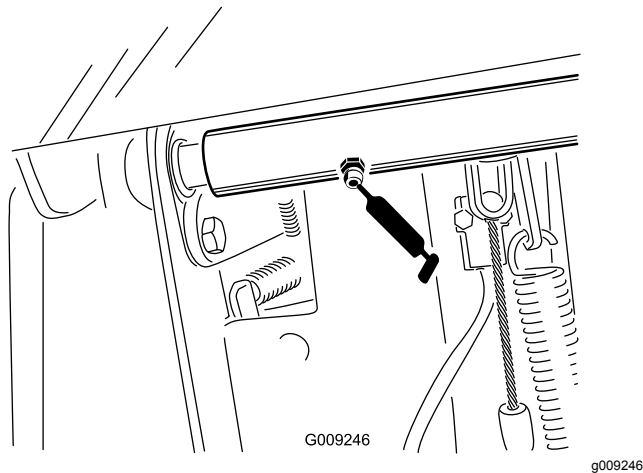

Figure 60

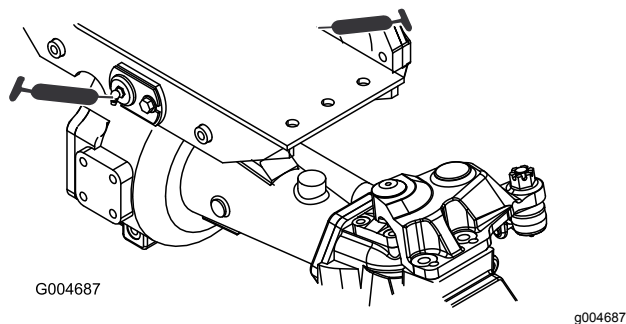

Figure 61

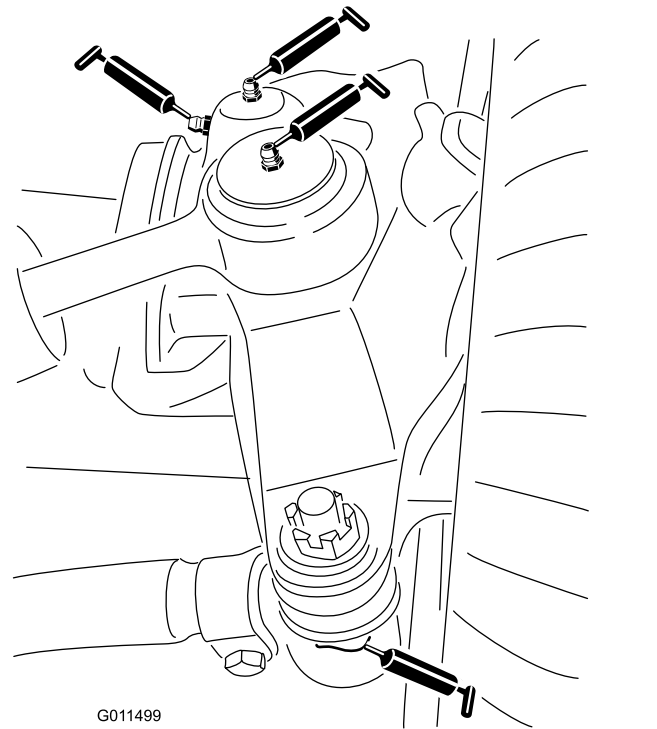

Figure 62

Center Cutting Unit

Note: Deck may have to be raised to expose the grease fittings for the latch pivot and the lower link.

Latch pivot (2) (Figure 64)

Note: The latch (Figure 63) may need to be manually tripped to gain access to the grease fitting. Use a prybar to close and re-open the latch

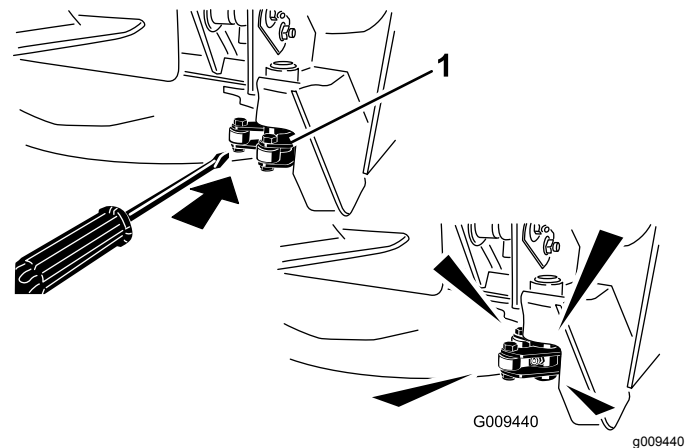
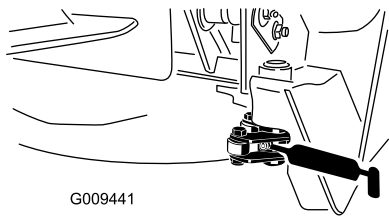

Figure 63

1. Latch



G009441

Figure 64

g009441

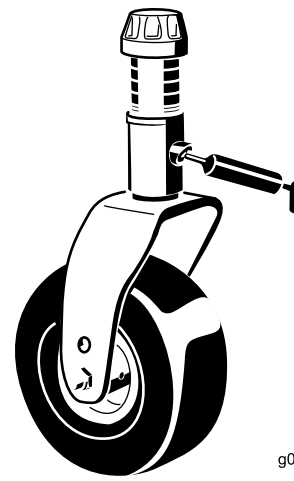

g011557

Figure 65

g011557

- Castor fork shaft bushings (2) (Figure 65)
- Spindle shaft bearings (3) (located under the pulley) (Figure 66)
- Idler arm pivot bushings (2) (Figure 66)

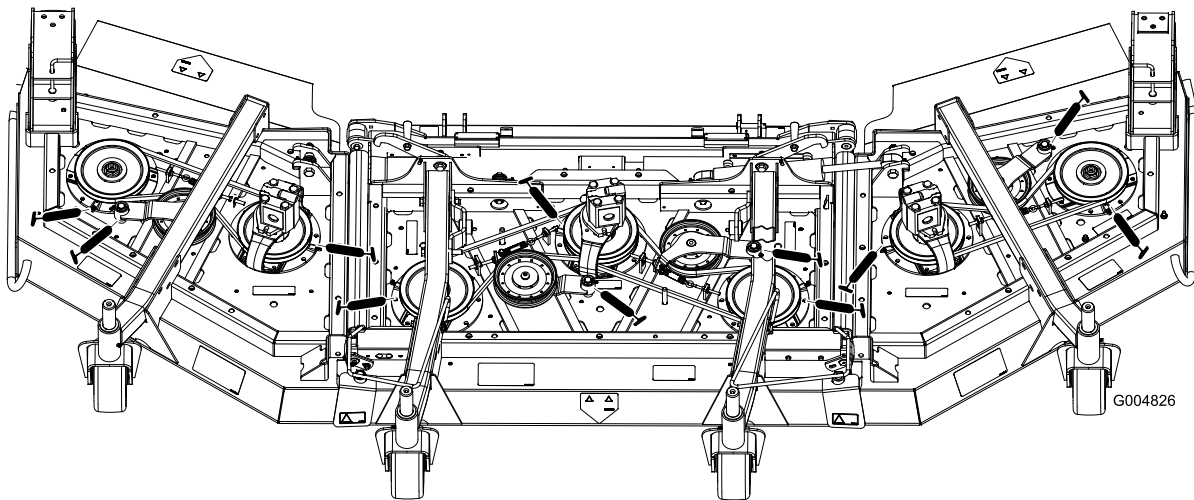

G004826

Figure 66

g004826

Center Lift Assemblies

- Lift arm cylinder bushings (2 each) (Figure 67)
- Lift arm ball joints (2) (Figure 68)

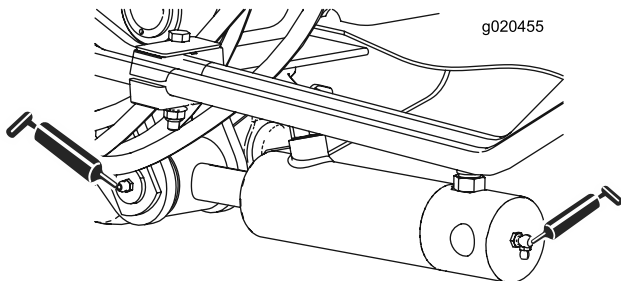

g020455

Figure 67

g020455

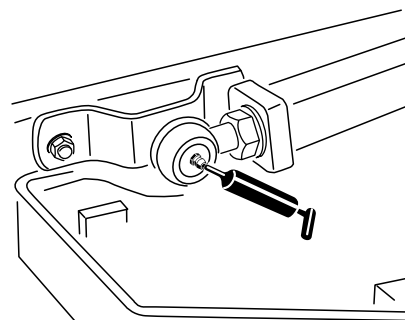

g011551

Figure 68

g011551

Wing Lift Assemblies

Wing lift cylinder (4) (Figure 69)

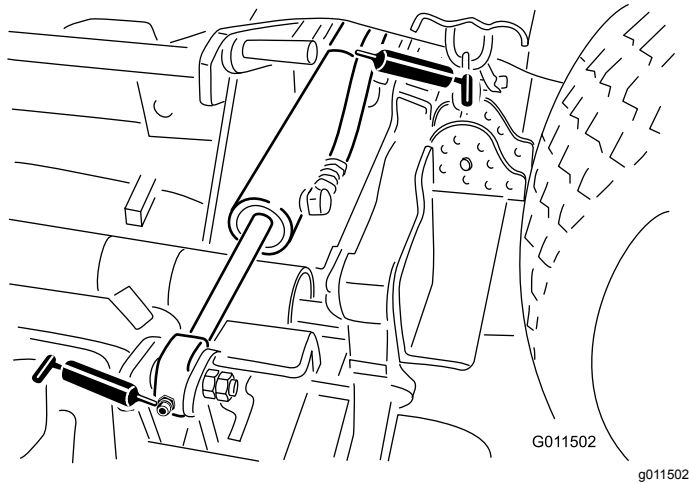

Figure 69

Wing Cutting Units

- Castor fork shaft bushing (1) (Figure 70)
- Spindle shaft bearings (2 each) (located under the pulley)
- Idler arm pivot bushings (1) (located on the idler arm)

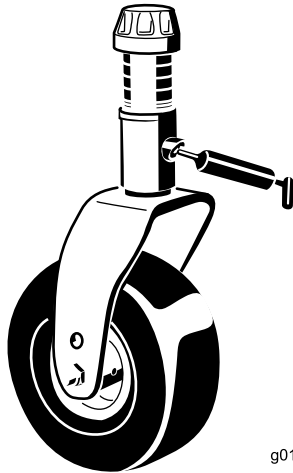

Figure 70

Engine Maintenance

Air Cleaner Maintenance

- Check the air cleaner body for damage which could cause an air leak. Replace if damaged. Check the whole intake system for leaks, damage or loose hose clamps.
- Service the air cleaner filter only when the service indicator requires it or every 400 hours (more frequently in extremely dusty or dirty conditions). Changing the air filter before it is necessary only increases the chance of dirt entering the engine when the filter is removed.
- Be sure the cover is seated correctly and seals with the air cleaner body.

Servicing the Air Cleaner

Service Interval: Before each use or daily

Every 50 hours

Every 400 hours

1. Pull the latch outward and rotate the air cleaner cover counterclockwise (Figure 71).
2. Remove the cover from the air cleaner body. Before removing the filter, use low pressure air (40 psi, clean and dry) to help remove large accumulations of debris packed between outside of primary filter and the canister. Avoid using high pressure air which could force dirt through the filter into the intake area. This cleaning process prevents debris from migrating into the intake when the primary filter is removed.

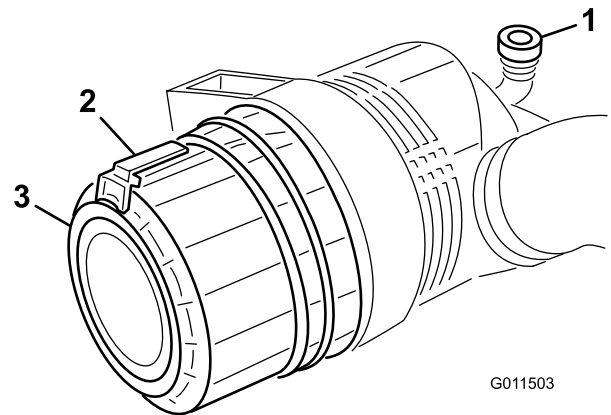

Figure 71

1. Air cleaner indicator
2. Air cleaner latch
3. Air cleaner cover

3. Remove the primary filter (Figure 72). Cleaning of the used element is not recommended due to the possibility of damage to the filter media. Inspect the new filter for shipping damage, checking the sealing end of the filter and the

body. Do not use a damaged element. **Do not** remove the safety filter (Figure 73).

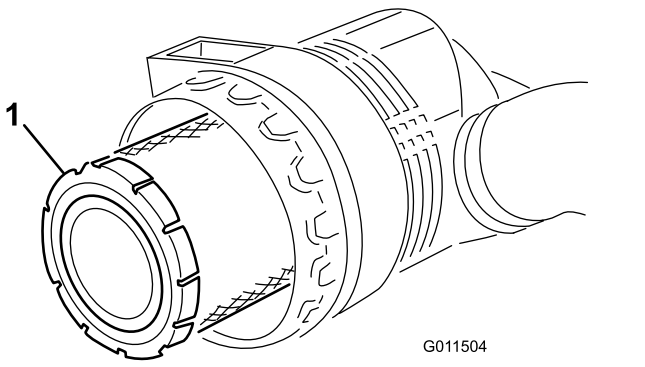

Figure 72

1. Air cleaner primary filter

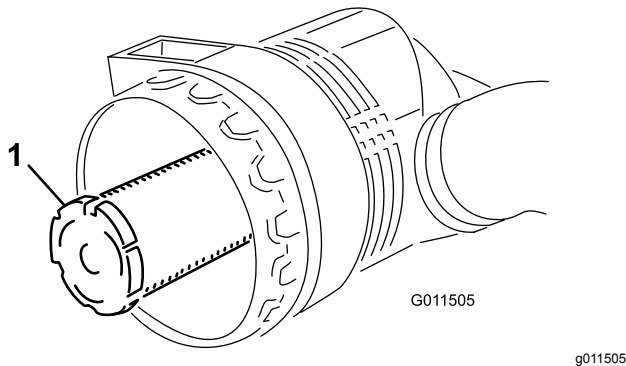

Figure 73

1. Air cleaner safety filter

Important: Never attempt to clean the safety filter (Figure 73). Replace the safety filter with a new one after every three primary filter services.

4. Replace the primary filter (Figure 72).
5. Insert the new filter by applying pressure to the outer rim of the element to seat it in the canister. Do not apply pressure to the flexible center of the filter.
6. Clean the dirt ejection port located in the removable cover. Remove the rubber outlet valve from the cover, clean the cavity and replace the outlet valve.
7. Install the cover orienting the rubber outlet valve (Figure 71) in a downward position - between approximately 5:00 to 7:00 when viewed from the end. Secure the latch.

Servicing the Engine Oil

Oil Specification

Use high-quality, low-ash engine oil that meets or exceeds the following specifications:

- API service category CJ-4 or higher
- ACEA service category E6
- JASO service category DH-2

Important: Using engine oil other than API CJ-4 or higher, ACEA E6, or JASO DH-2 may cause the diesel particulate filter to plug or cause engine damage.

Use the following engine oil viscosity grade:

- Preferred oil: SAE 15W-40 (above 0°F)
- Alternate oil: SAE 10W-30 or 5W-30 (all temperatures)

Toro Premium Engine Oil is available from your Authorized Toro Distributor in either 15W-40 or 10W-30 viscosity grades. See the parts catalog for part numbers.

Checking the Engine-Oil Level

Service Interval: Before each use or daily

Important: Check the engine oil daily. If the engine-oil level is above the Full mark on the dipstick, the engine oil may be diluted with fuel; If the engine oil level is above the Full mark, change the engine oil.

The best time to check the engine oil is when the engine is cool before it has been started for the day. If it has already been run, allow the oil to drain back down to the sump for at least 10 minutes before checking. If the oil level is at or below the Add mark on the dipstick, add oil to bring the oil level to the Full mark. **Do not overfill the engine with oil.**

Important: Keep the engine oil level between the upper and lower limits on the oil gauge; the engine may fail if you run it with too much or too little oil.

1. Park the machine on a level surface. Unlock the engine cover latches.
2. Open the engine cover.
3. Remove the dipstick, wipe it clean, install the dipstick into the tube, and pull it out again. The oil level should be between the full and add marks (Figure 74).

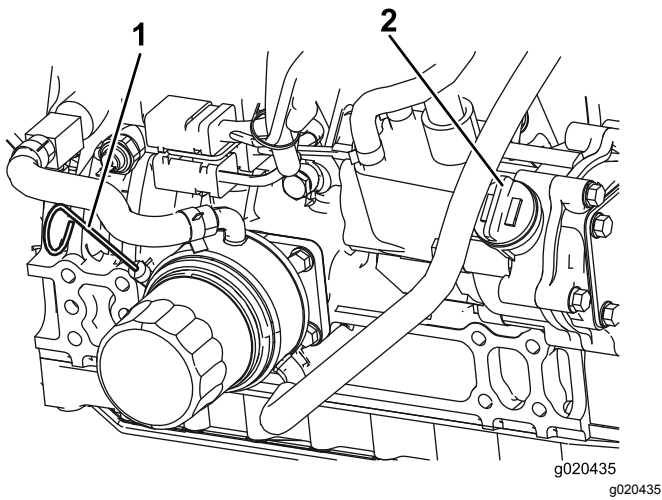

Figure 74

4. If the oil level is low, remove the fill cap (Figure 10) and add oil until it is between the full and add marks. Do not overfill.
5. Install the oil fill cap and dipstick.
6. Close the engine cover and secure it with the latches.

Crankcase Oil Capacity

5.7 L (6 quarts)

Servicing the Engine Oil and Filter

Service Interval: Every 250 hours

Change the oil and filter every 250 hours.

1. Remove the drain plug (Figure 75) and let the oil flow into a drain pan. When all the oil is drained, install the drain plug.

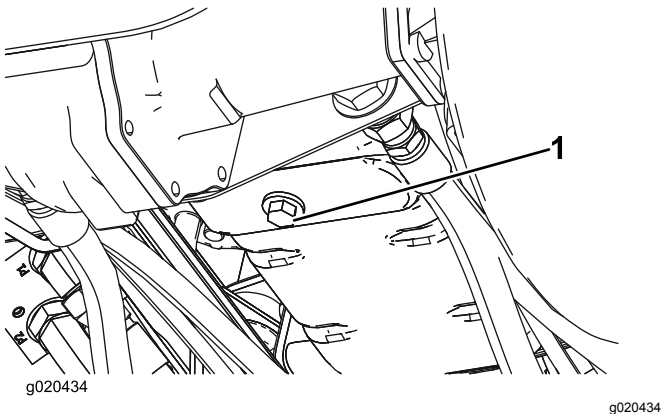

Figure 75

1. Engine oil drain plug

2. Remove the oil filter (Figure 76). Apply a light coat of clean oil to the new filter seal before screwing it on. **Do not overtighten.**

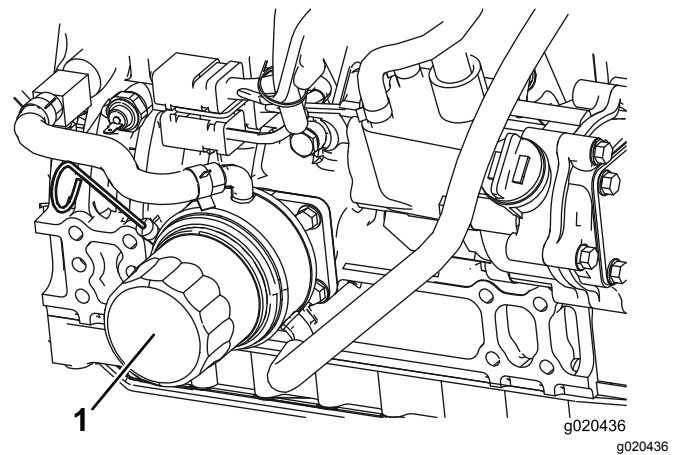

Figure 76

1. Engine oil filter

3. Add oil to the crankcase; refer to Checking the Engine Oil.

Servicing the Diesel-Oxidation Catalyst (DOC) and the Soot Filter

Service Interval: Every 6,000 hours or clean the soot filter if engine faults SPN 3720 FMI 16, SPN 3720 FMI 0, or SPN 3720 FMI 16 display in the InfoCenter.

- If advisory message ADVISORY 179 displays in the InfoCenter, the DPF is nearing the recommended point for servicing the diesel-oxidation catalyst and the soot filter.

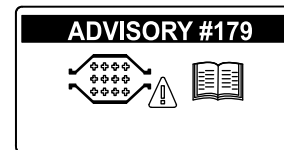
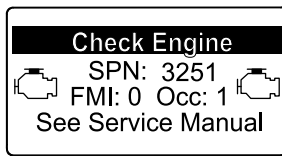
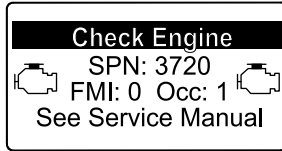

Figure 77

- If engine faults CHECK ENGINE SPN 3251 FMI 0, CHECK ENGINE SPN 3720 FMI 0, or CHECK ENGINE SPN 3720 FMI 16 in the InfoCenter (Figure 78) display in the InfoCenter, clean the soot filter using the steps that follow:



g214715



g213864

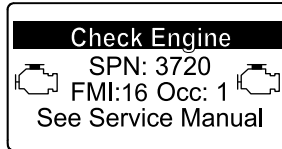

g213863

Figure 78

1. Refer to the Engine section in the *Service Manual* for information on disassembling and assembling the diesel-oxidation catalyst and the soot filter of the DPF.
2. Refer to your Authorized Toro Distributor for diesel-oxidation catalyst and the soot filter replacement parts or service.
3. Contact your Authorized Toro Distributor to have them reset the engine ECU after you install a clean DPF.

Fuel System Maintenance

Servicing the Fuel System

⚠ DANGER

Under certain conditions, diesel fuel and fuel vapors are highly flammable and explosive. A fire or explosion from fuel can burn you and others and can cause property damage.

- Use a funnel and fill the fuel tank outdoors, in an open area, when the engine is off and is cold. Wipe up any fuel that spills.
- Do not fill the fuel tank completely full. Add fuel to the fuel tank until the level is 6 to 13 mm (1/4 to 1/2 inch) below the bottom of the filler neck. This empty space in the tank allows the fuel to expand.
- Never smoke when handling fuel, and stay away from an open flame or where fuel fumes may be ignited by a spark.
- Store fuel in a clean, safety-approved container and keep the cap in place.

Fuel Tank

Service Interval: Every 800 hours

Drain and clean the fuel tank every 800 hours. Also, drain and clean the tank if fuel system becomes contaminated or if the machine will be stored for an extended period of time. Use clean fuel to flush out the tank.

Fuel Lines and Connections

Service Interval: Every 400 hours

Check the fuel lines and connections every 400 hours or yearly, whichever comes first. Inspect them for deterioration, damage, or loose connections.

Servicing the Water Separator

Service Interval: Before each use or daily
Every 400 hours

Drain water or other contaminants from water separator (Figure 79) daily. Replace filter canister after every 400 hours of operation.

1. Place a clean container under the fuel filter.

- Loosen the drain plug on the bottom of the filter canister and open the vent on the top of the canister mount.

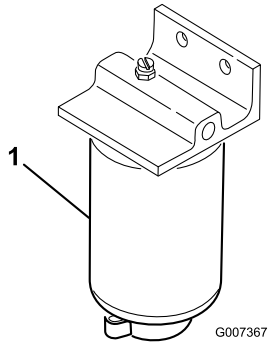

Figure 79

- Water separator filter canister

- Clean the area where the filter canister mounts.
- Remove the filter canister and clean the mounting surface.
- Lubricate the gasket on the filter canister with clean oil.
- Install the filter canister by hand until the gasket contacts mounting surface, then rotate it an additional 1/2 turn.
- Tighten the drain plug on the bottom of the filter canister and close the vent on the top of the canister mount.

Servicing the Engine Fuel Filter

Service Interval: Every 400 hours

The engine fuel filter should be replaced after every 400 hours of operation.

- Clean the area around the fuel filter head (Figure 80).

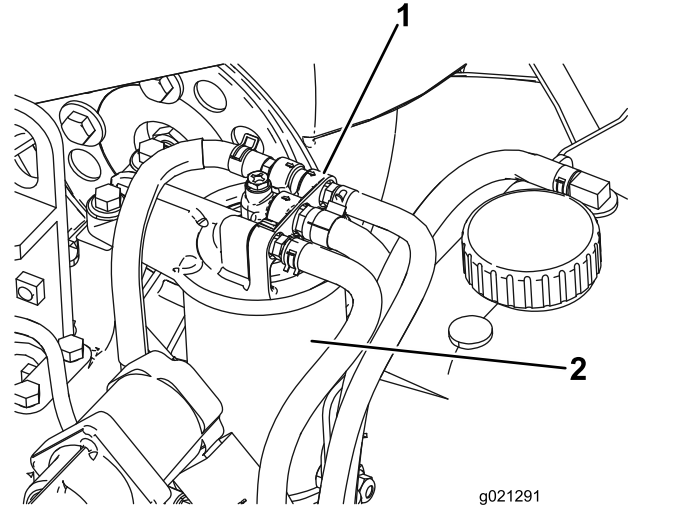

Figure 80

- Fuel Filter head
- Fuel Filter

- Remove the filter and clean the filter head mounting surface (Figure 80).
- Lubricate the filter gasket with clean lubricating engine oil. Refer to the Engine Operator's Manual, included with the machine, for additional information.
- Install the dry filter canister, by hand, until the gasket contacts the filter head, then rotate it an additional 1/2 turn.
- Start the engine and check for fuel leaks around the filter head.

Electrical System Maintenance

Battery Care

Battery type is group 24.

Important: Before welding on the machine, disconnect the negative cable from the battery to prevent damage to the electrical system.

Note: Check the battery condition weekly or after every 50 hours of operation. Keep the terminals and the entire battery case clean because a dirty battery will discharge slowly. To clean the battery, wash the entire case with a solution of baking soda and water. Rinse with clear water. Coat the battery posts and cable connectors with Grafo 112X (skin-over) grease (Toro Part No. 505-47) or petroleum jelly to prevent corrosion.

▲ WARNING

CALIFORNIA Proposition 65 Warning

Battery posts, terminals, and related accessories contain lead and lead compounds, chemicals known to the State of California to cause cancer and reproductive harm. Wash hands after handling.

1. Open the battery cover (Figure 81). on the side of the shroud.

Note: Press down on the flat surface above the battery cover to ease cover removal (Figure 81).

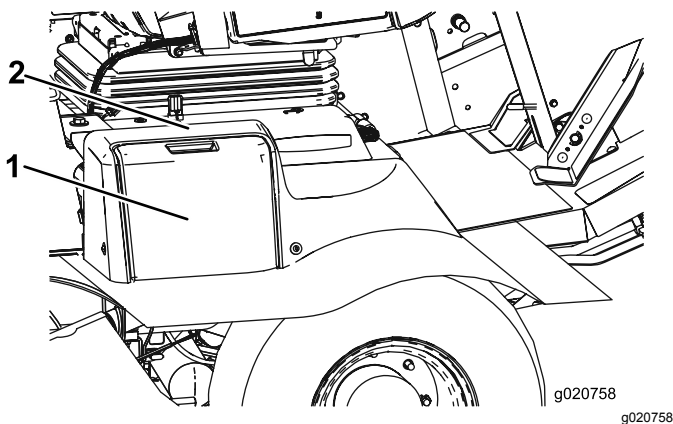

Figure 81

1. Battery cover
2. Press down here

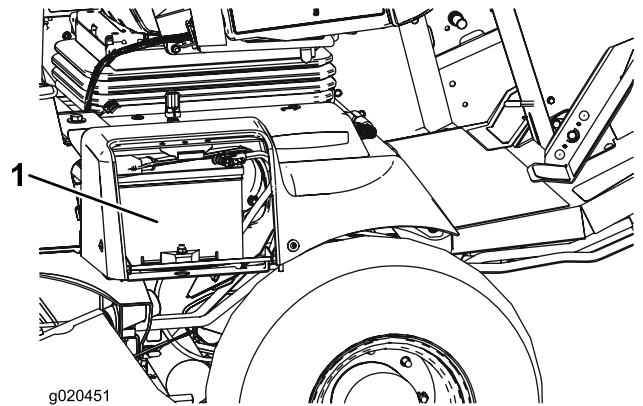

Figure 82

1. Battery

▲ WARNING

Charging the battery produces gasses that can explode.

Never smoke near the battery and keep sparks and flames away from battery.

2. Remove the rubber boot from the positive terminal and inspect the battery.

▲ WARNING

Battery terminals or metal tools could short against metal components causing sparks. Sparks can cause the battery gasses to explode, resulting in personal injury.

- When removing or installing the battery, do not allow the battery terminals to touch any metal parts of the machine.
- Do not allow metal tools to short between the battery terminals and metal parts of the machine.

⚠ WARNING

Incorrect battery cable routing could damage the machine and cables causing sparks. Sparks can cause the battery gasses to explode, resulting in personal injury.

- Always *disconnect* the negative (black) battery cable before disconnecting the positive (red) cable.
 - Always *connect* the positive (red) battery cable before connecting the negative (black) cable.
3. Coat both battery connections with Grafo 112X (skin-over) grease, Toro Part No. 505-47, petroleum jelly, or light grease to prevent corrosion. Slide the rubber boot over the positive terminal.
 4. Close the battery cover.

Fuses

The traction unit fuses (Figure 83 thru Figure 85) are located under the power center cover.

Remove the two Allen head screws securing the power center cover to the frame and remove the cover (Figure 83).

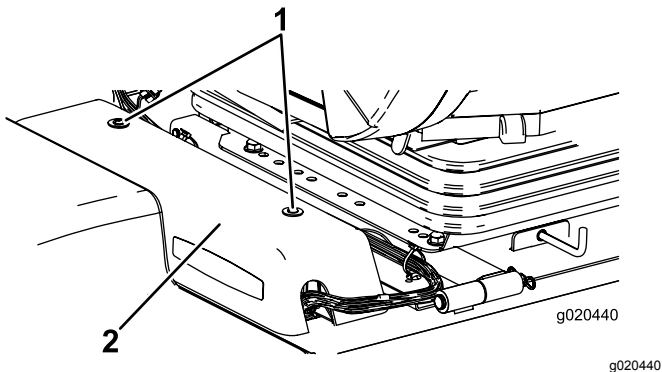

Figure 83

1. Power center cover
2. Allen head screws (2)

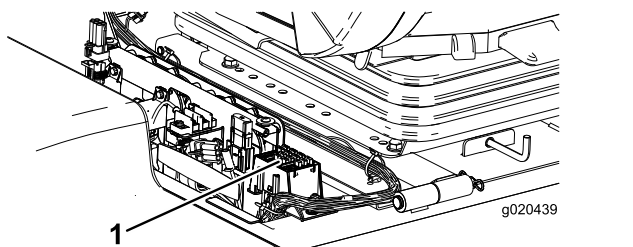

Figure 84

1. Fuses

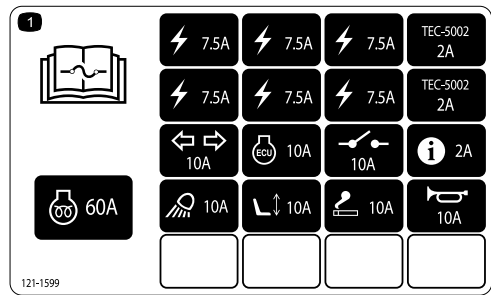

Figure 85

decal121-1599

The cab fuses (Figure 86 & Figure 87) are located in the fuse box in the cab headliner (Cab model only).

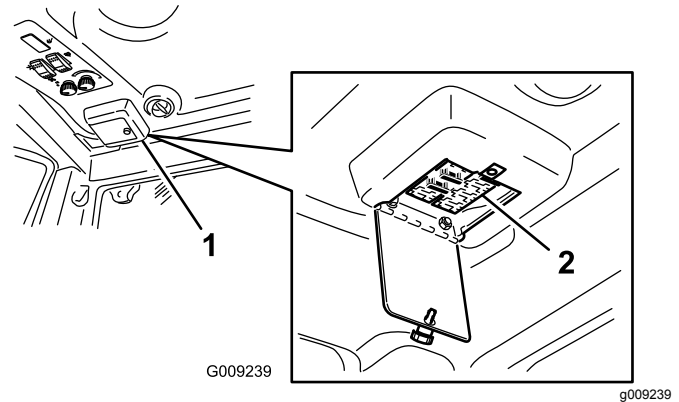

Figure 86

1. Cab fuse box
2. Fuses

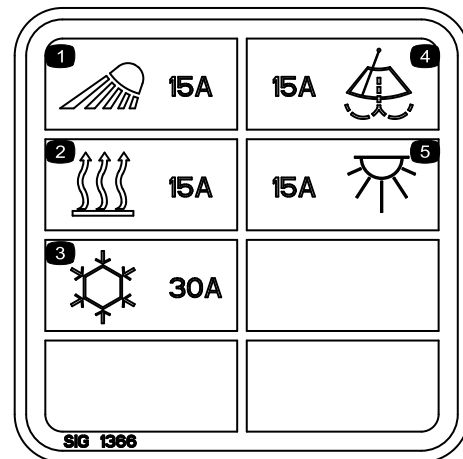

Figure 87

decal117-2787

Drive System Maintenance

Adjusting the Traction Pedal Angle

The traction pedal operating angle can be adjusted for operator comfort.

1. Loosen the two nuts and bolts securing the left side of the traction pedal to the bracket (Figure 88).

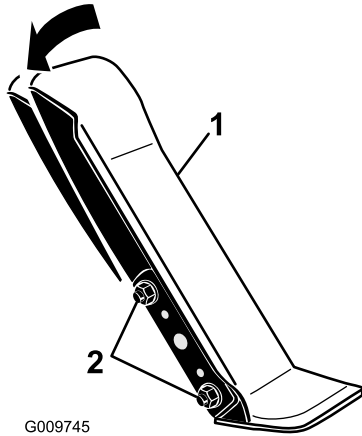

Figure 88

1. Traction pedal
2. Mounting nuts and bolts (2)

2. Pivot the pedal to the desired operating angle and tighten the nuts (Figure 88).

Changing the Planetary Gear Drive Oil

Service Interval: After the first 200 hours

Every 800 hours (Or yearly, whichever comes first)

Change the oil initially after first 200 hours of operation. Thereafter change the oil every 800 hours, or yearly, whichever occurs first. Use a high quality SAE 85W-140 gear lube.

1. With the machine on a level surface, position a wheel so that one of the check plugs is at the lowest (6 o'clock) position (Figure 89).

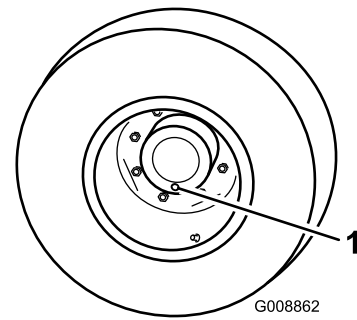

Figure 89

1. Check/drain plug

2. Place a drain pan under the planetary hub, remove plug and allow oil to drain.
3. Place a drain pan under the brake housing, remove the drain plug and allow the oil to drain (Figure 42).

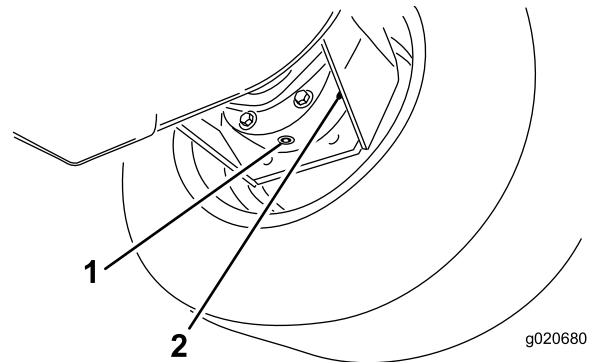

Figure 90

1. Drain plug
2. Brake housing

4. When all of the oil has drained from both locations, re-install the plug in the brake housing.
5. Rotate the wheel until the open plug hole in the planetary is at the twelve o'clock position.
6. Through the open hole, slowly fill the planetary with 0.65 liter (22 ounces) of high quality SAE 85W-140 wt. gear lube.

Important: If the planetary fills before the 0.65 liter (22 ounces) of oil is added, wait one hour or install the plug and move the machine approximately ten feet to distribute the oil through the brake system. Then, remove the plug and add the remaining oil.

7. Re-install the plug.
8. Repeat the procedure on the opposite planetary/brake assembly.

Changing the Rear Axle Lubricant

Service Interval: After the first 200 hours

Every 800 hours

Change the oil initially after the first 200 hours of operation and every 800 hours of operation thereafter.

1. Position the machine on a level surface.
2. Clean the area around the 3 drain plugs; 1 on each end and 1 in the center (Figure 91).
3. Remove the check plugs to ease in draining of the oil.
4. Remove the drain plugs and allow the oil to drain into the pans.

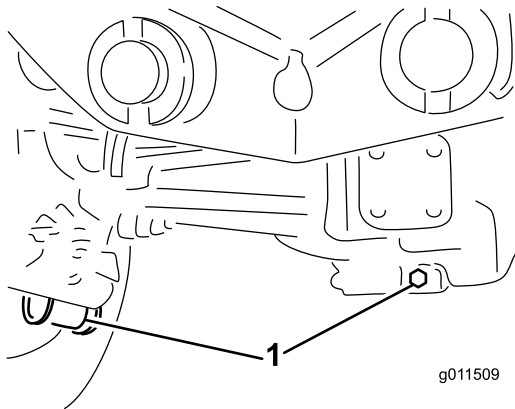

Figure 91

1. Drain plug location

5. Clean the area around the drain plug on the bottom of the gear box (Figure 92).
6. Remove the drain plug from the gear box and allow the oil to drain into a pan. Remove the fill plug to ease in draining of the oil.

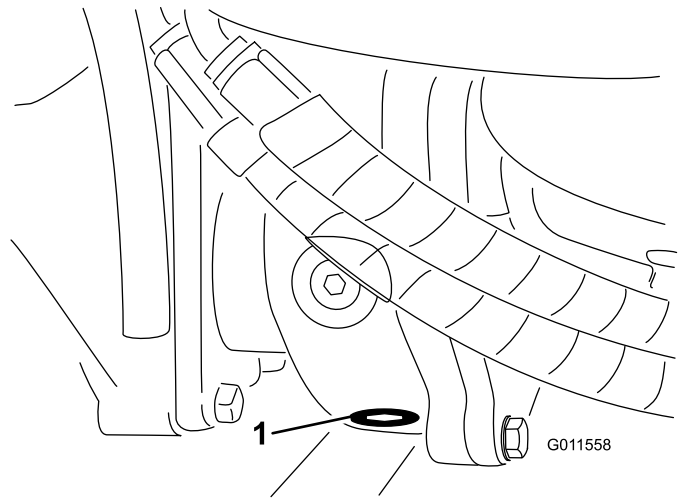

Figure 92

1. Drain plug

7. Add enough oil to bring the level up to the bottom of the check plug holes; refer to Checking the Rear Axle Lubricant, and Checking the Rear Axle Gear Box Lubricant.
8. Install the plugs.

Checking the Rear Wheel Toe-In

Service Interval: Every 800 hours

After every 800 operating hours or annually, check the rear wheel toe-in.

1. Measure the center-to-center distance (at axle height) at the front and rear of the steering tires. The front measurement must be 6 mm (1/4 inch) less than the rear measurement.
2. To adjust, loosen the clamps at both ends of the tie rods.
3. Rotate the tie rod end to move the front of the tire inward or outward.
4. Tighten the tie rod clamps when the adjustment is correct.

Changing the Front Tires

1. Lower the wing cutting units to the ground.
2. Raise the front of the machine several inches off the ground and support w/jackstands.
3. Refer to Pivoting (Tilting) the Front Cutting Unit Upright in Mower Maintenance.
4. Pivot Cutting unit forward to allow removal of the tire requiring service .

Cooling System Maintenance

Servicing the Engine Cooling System

Remove debris from the oil radiator/oil cooler daily. Clean them more frequently in dirty conditions.

This machine is equipped with a hydraulically driven fan drive system that automatically (or manually) reverses to reduce radiator/oil cooler and screen debris build-up. While this feature can help reduce the time required to clean radiator/oil cooler, it does not eliminate the need for routine cleaning. Periodic cleaning and inspection of the radiator/oil cooler is still required.

1. Turn the engine off and raise the hood. Clean the engine area thoroughly of all debris.
2. Clean both sides of the radiator/oil cooler area (Figure 93) thoroughly with compressed air. Start from the fan side and blow the debris out towards the back. Then clean from the back side and blow towards the front. Repeat procedure several times until all chaff and debris is removed.

Important: Cleaning the radiator/oil cooler with water can promote premature corrosion and damage to components.

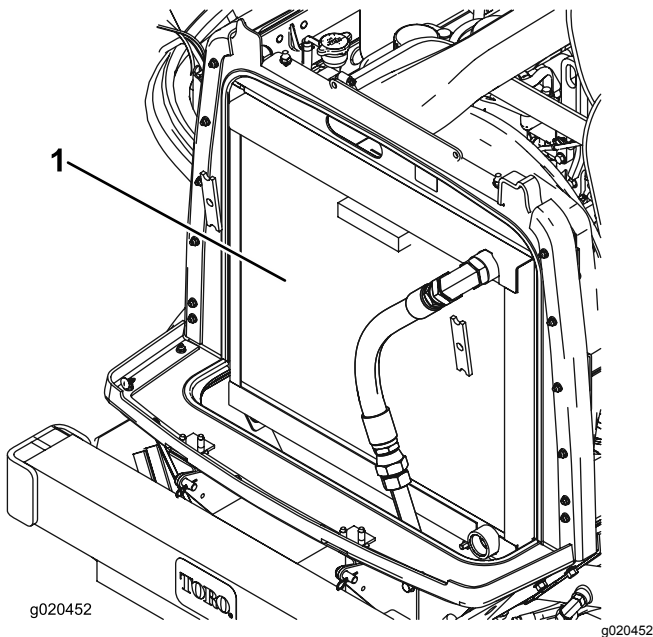

Figure 93

1. Radiator/oil cooler

3. Close the hood.

Brake Maintenance

Adjusting the Service Brakes

Adjust the service brakes when there is more than 25 mm (1 inch) of “free travel” of the brake pedal, or when the brakes do not work effectively. Free travel is the distance the brake pedal moves before braking resistance is felt.

1. Disengage the locking latch from the brake pedals so that both pedals work independently of each other.
2. To reduce free travel of the brake pedals, tighten the brakes:
 - A. Loosen the 2 mounting screws and remove the brake adjustment cover (Figure 94).

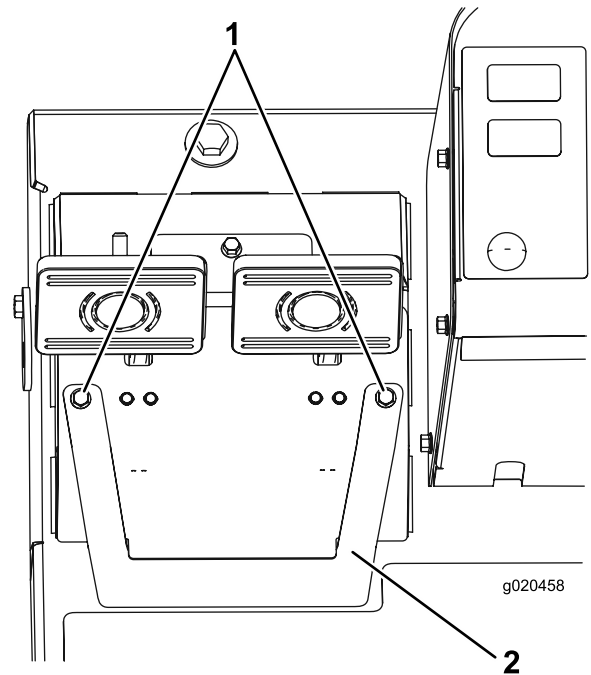

Figure 94

1. Mounting screws
2. Brake adjustment cover

- B. Loosen the front nut on the threaded end of the brake cable (Figure 95).

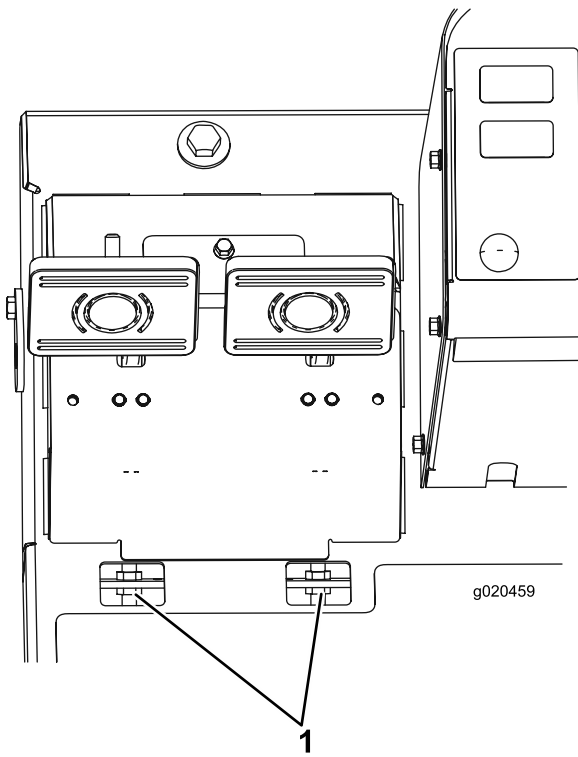

Figure 95

1. Brake cable adjusting nuts

- C. Tighten the rear nut to move the cable backward until the brake pedals have 13 to 25 mm (1/2 to 1 inch) of free travel.
- D. Tighten the front nuts after the brakes are adjusted correctly.
- E. Reinstall the brake adjustment cover.

Belt Maintenance

Servicing the Alternator Belt

Service Interval: After the first 10 hours
Every 100 hours

Check the condition and tension of the belt ([Figure 96](#)) after every 100 operating hours.

1. Proper tension will allow 10 mm (3/8 inch) deflection when a force of 44 N (10 lb) is applied on the belt midway between the pulleys.
2. If the deflection is not 10 mm (3/8 inch), loosen the alternator mounting bolts ([Figure 96](#)). Increase or decrease the alternator belt tension and tighten the bolts. Check the deflection of the belt again to ensure that the tension is correct.

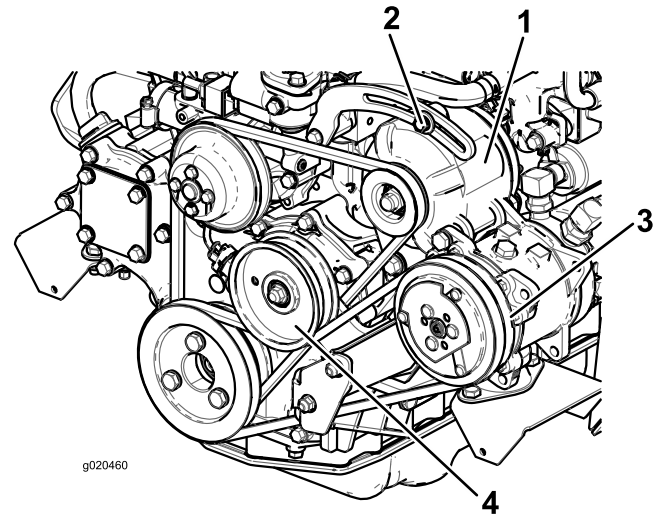

Figure 96

- | | |
|------------------|-----------------|
| 1. Alternator | 3. Compressor |
| 2. Mounting bolt | 4. Idler pulley |

Servicing the Compressor Belt

Service Interval: After the first 10 hours
Every 100 hours

Cab model only

Check the condition and tension of the belt ([Figure 96](#)) after every 100 operating hours.

1. Proper tension will allow 10 mm (3/8 inch) deflection when a force of 44 N (10 lb) is applied on the belt midway between the pulleys.
2. If the deflection is not 10 mm (3/8 inch), loosen the idler pulley mounting bolt ([Figure](#)

96). Increase or decrease the compressor belt tension and tighten the bolt. Check the deflection of the belt again to ensure that the tension is correct.

Re-tensioning the Blade Drive Belts

Service Interval: After the first 10 hours

Every 50 hours

Check the condition and tension of the cutting unit drive belts initially after 10 hours of operation and every 50 operating hours thereafter.

When properly tensioned, the extension spring (hook to hook) measurement should be approximately 8.9 cm \pm .63 cm (3.50 \pm .25 inch) (inside). Once the correct spring tension is attained, adjust the stop bolt (carriage bolt) until there is approximately .32 cm \pm .152/.000 cm (.125 \pm .060/-.000 inch) clearance between the head of the bolt and the idler arm (Figure 97).

Note: Make sure the belt is positioned on the spring side of the belt guide (Figure 97).

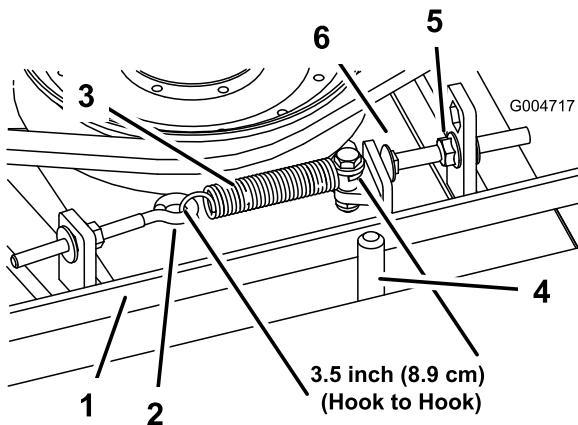

Figure 97

- | | |
|---------------------|---------------|
| 1. Belt | 4. Belt guide |
| 2. Eye bolt | 5. Flange nut |
| 3. Extension spring | 6. Stop bolt |

Replacing the Blade Drive Belt

Service Interval: Every 800 hours

The blade drive belt, tensioned by the spring loaded idler pulley, is very durable. However, after many hours of use, the belt will show signs of wear. Signs of a worn belt are: squealing when belt is rotating, blades slipping when cutting grass, frayed edges, burn marks and cracks. Replace the belt if any of these conditions are evident.

1. Lower the cutting unit to the shop floor. Remove the belt covers from the top of the cutting unit and set the covers aside.
2. Loosen the eye bolt allowing the removal of the extension spring (Figure 97).
3. Loosen the flange nut securing the stop bolt to the mounting tab. Back off the nut enough to allow the idler arm to pass by the stop bolt (Figure 97). Move the idler pulley away from the belt to release belt tension.

Note: If the stop bolt is ever removed from the mounting tab, make sure it is reinstalled in the hole that aligns the stop bolt head with the idler arm.

4. Remove the bolts securing the hydraulic motor to the cutting unit (Figure 98). Lift the motor off of the cutting unit and lay it on top of the cutting unit.

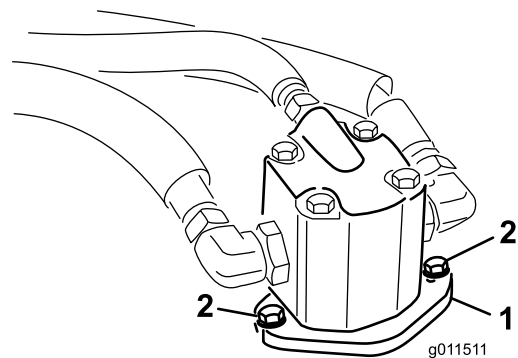

Figure 98

- | | |
|--------------------|-------------------|
| 1. Hydraulic motor | 2. Mounting bolts |
|--------------------|-------------------|

5. Remove the old belt from around the spindle pulleys and idler pulley.
6. Route the new belt around the spindle pulleys and idler pulley assembly.
7. Position the hydraulic motor on the cutting unit after routing the belt around the pulleys. Mount the motor to the cutting unit with the bolts previously removed.

Note: Make sure the belt is positioned on the spring side of the belt guide (Figure 97).

8. Reconnect the extension spring (Figure 97) to the eye bolt and tension the belt as follows:
 - When properly tensioned, the extension spring (hook to hook) measurement should be approximately 8.9 cm ± .63 cm (3.50 ± .25 inch (inside)).
 - Once the correct spring tension is attained, adjust the stop bolt (carriage bolt) until there is approximately .32 cm ± .152/.000 cm (.125 ± .060/- .000 inch) clearance between the head of the bolt and the idler arm.

Hydraulic System Maintenance

Changing the Hydraulic Fluid

Service Interval: Every 800 hours

Change the hydraulic fluid after every 800 operating hours, in normal conditions. If the fluid becomes contaminated, contact your local Toro distributor because the system must be flushed. Contaminated fluid looks milky or black when compared to clean oil.

1. Turn the engine off and raise the hood.
2. Remove the drain plug on the bottom front of the reservoir and let the hydraulic fluid flow into large drain pan. Install and tighten the plug when the hydraulic fluid stops draining.
3. Fill the reservoir (Figure 99) with hydraulic fluid; refer to Checking the Hydraulic Fluid.

Important: Use only the hydraulic fluids specified. Other fluids could cause system damage.

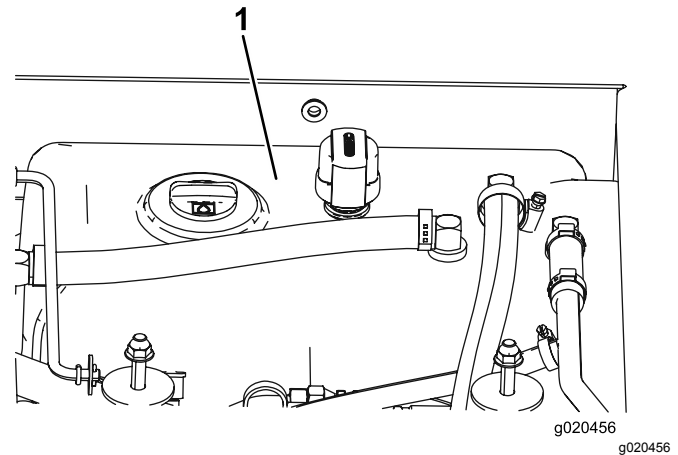

Figure 99

1. Hydraulic reservoir

4. Install the reservoir cap. Start the engine and use all of the hydraulic controls to distribute hydraulic fluid throughout the system. Also check for leaks; then stop the engine.
5. Check the fluid level and add enough to raise level until it is between the add and full marks on the dipstick. **Do not overfill.**

Replacing the Hydraulic Filters

Service Interval: Every 800 hours

Change the 2 hydraulic filters after every 800 operating hours, in normal conditions.

Use Toro replacement filters (Part No. 94-2621 for the left side of the machine and 75-1310 for the right side of the machine).

Important: Use of any other filter may void the warranty on some components.

1. Position the machine on a level surface, lower the cutting units, stop the engine, engage the parking brakes, and remove the ignition key.
2. Clean the area around the filter mounting areas. Place a drain pan under the filter and remove the filter (Figure 100).

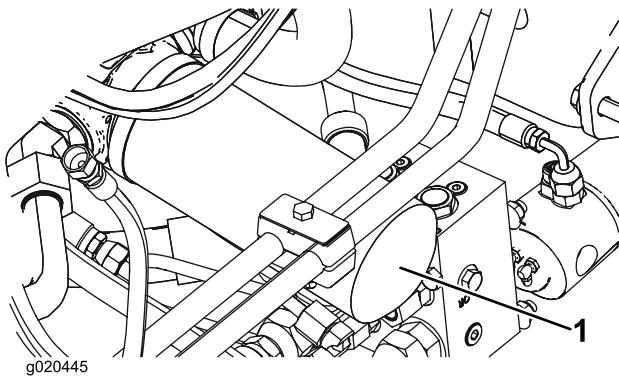

Figure 100

1. Hydraulic filter

3. Lubricate the new filter gasket and fill the filter with hydraulic fluid.
4. Ensure that the filter mounting area is clean. Screw the filter on until the gasket contacts the mounting plate; then tighten the filter an additional 1/2 turn.
5. Repeat the procedure on other filter (Figure 101).

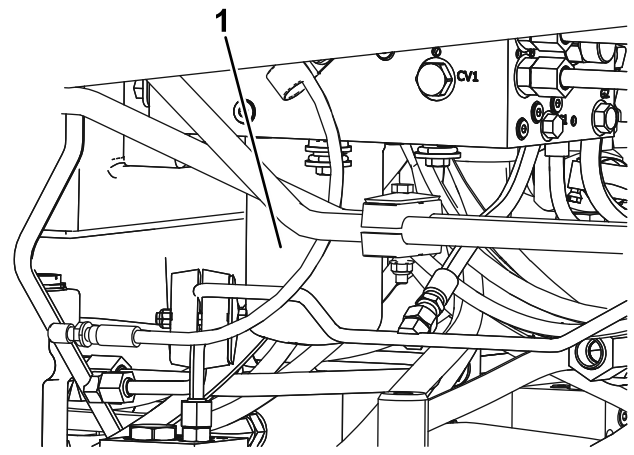

Figure 101

1. Hydraulic filter

6. Once the reservoir is filled, start the engine and let it run at low idle for approximately two minutes. Activate steering and raise/lower cutting units several times to purge air from the system. Stop the engine and check for leaks.

Checking the Hydraulic Lines and Hoses

Service Interval: Every 2 years

Inspect the hydraulic lines and hoses daily for leaks, kinked lines, loose mounting supports, wear, loose fittings, weather deterioration, and chemical deterioration. Make all necessary repairs before operating.

⚠ WARNING

Hydraulic fluid escaping under pressure can penetrate skin and cause injury.

- **Make sure all hydraulic fluid hoses and lines are in good condition and all hydraulic connections and fittings are tight before applying pressure to the hydraulic system.**
- **Keep your body and hands away from pin hole leaks or nozzles that eject high pressure hydraulic fluid.**
- **Use cardboard or paper to find hydraulic leaks.**
- **Safely relieve all pressure in the hydraulic system before performing any work on the hydraulic system.**
- **Seek immediate medical attention if fluid is injected into skin.**

Adjusting the Counterbalance Pressure

The counterbalance test port (Figure 102) is used to test the pressure in the counterbalance circuit. Recommended counterbalance pressure is 2241 kPa (325 psi). To adjust the counterbalance pressure, loosen the locknut, rotate the adjusting screw (Figure 102) clockwise to increase the pressure or counterclockwise to decrease the pressure and tighten the locknut. The engine must be running at high idle, the deck lowered and in float to check pressure.

Note: The castor wheels of all three cutting units should remain on the ground when adjusting the counterbalance and with counterbalance applied.

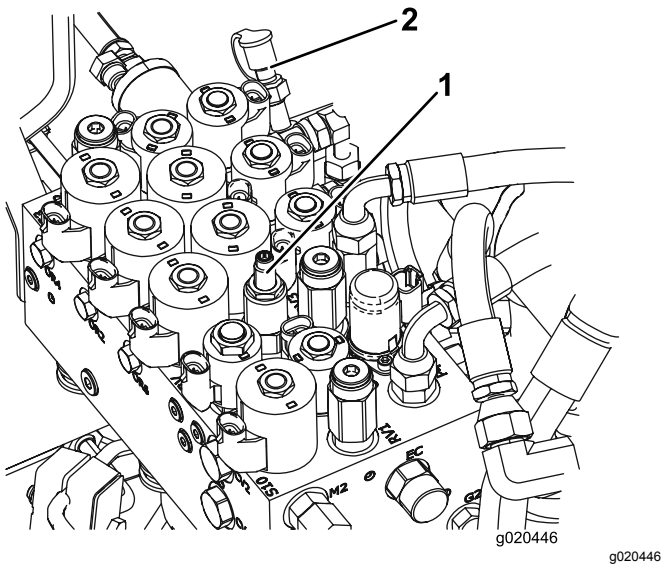

Figure 102

1. Counterbalance adjusting screw
2. Counterbalance test port

Mower Maintenance

Pivoting (Tilting) the Front Cutting Unit Upright

Note: Although not needed for normal maintenance procedures, the front cutting unit can be pivoted (tilted) to an upright position. Should you desire to tilt the cutting unit, proceed as follows:

1. Raise the front cutting unit slightly off of the floor, set the parking brake, and stop the engine. Remove the ignition key.
2. Remove the hairpin cotter securing dampers to lift arms (Figure 103). Pivot damper toward deck housing.

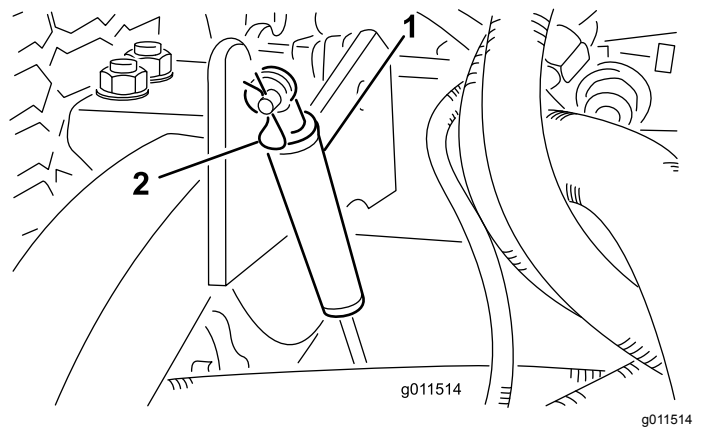

Figure 103

1. Damper
2. Hair pin cotter

3. Remove the hairpin cotter and clevis pin securing the height-of-cut chains to the rear of the cutting unit (Figure 104).

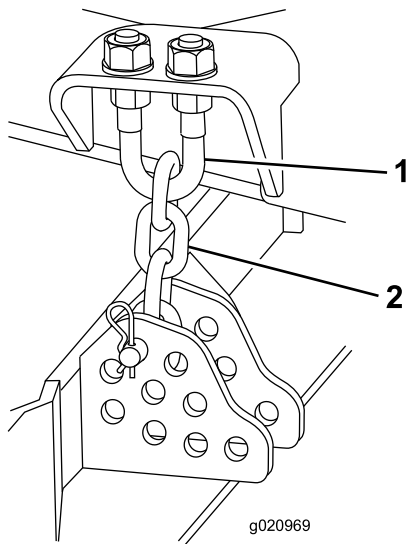

Figure 104

1. U-bolt
2. Height-of-cut chain

4. Start the engine and slowly raise the center cutting unit.
5. Slowly raise each wing cutting until the center of gravity shifts and the deck starts to rotate into the upright position. Stop the engine and remove the ignition key

Pivoting the Front Cutting Unit Down

1. Slowly lower wing cutting units until the center of gravity shifts and the center cutting unit rotates downward.
2. Sit on the seat, start the engine, and lower the center cutting unit until it is slightly off of the floor.
3. Secure the height-of-cut chains to the rear of the cutting unit.
4. Pivot dampers upward into position and secure with clevis pin and cotter pin.

Adjusting the Cutting Unit Pitch

Measuring the Cutting Unit Pitch

Cutting unit pitch is the difference in height-of-cut from the front of the blade plane to the back of the blade plane. Toro recommends a blade pitch of 8 to 11 mm (5/16 to 7/16 inch). That is the back of the blade plane is 8 to 11 mm (5/16 to 7/16 inch) higher than the front.

1. Position the machine on a level surface on the shop floor.

2. Set the cutting unit to the desired height-of-cut.
3. Rotate 1 blade so that it points straight forward.
4. Using a short ruler, measure from the floor to the front tip of the blade. Rotate the blade tip to the rear and measure from the floor to the tip of the blade.
5. Subtract the front dimension from the rear dimension to calculate the blade pitch.

Adjusting the Front Cutting Unit

1. Loosen the jam nuts on the top or bottom of the height-of-cut chain U-bolt (Figure 105).
2. Adjust the other set of nuts to raise or lower the rear of the cutting unit and attain the correct cutting unit pitch.
3. Tighten the jam nuts.

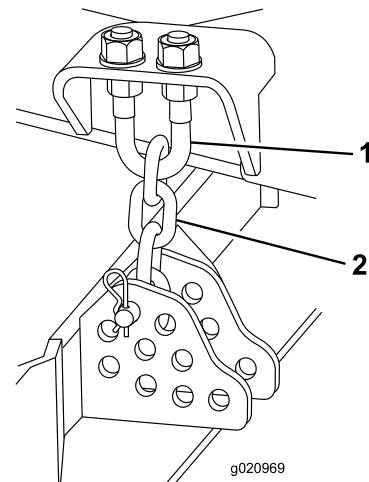

Figure 105

1. U-bolt
2. Height-of-cut chain

Adjusting the Wing Cutting Units

1. Remove the cap screws and nuts securing the castor arm to the castor fork (Figure 106).
2. Reposition the shims, as required, to raise or lower the castor wheel until the cutting unit has the correct pitch.
3. Install the cap screws and nuts.

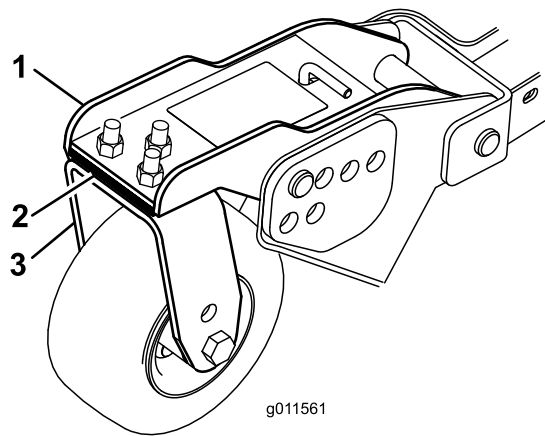

Figure 106

- | | |
|---------------|----------------|
| 1. Castor arm | 3. Castor fork |
| 2. Shims | |

Servicing the Castor Arm Bushings

The castor arms have bushings pressed into the top and bottom of the tube and after many hours of operation, the bushings will wear. To check the bushings, move the castor fork back and forth and from side to side. If the castor spindle is loose inside the bushings, the bushings are worn and must be replaced.

1. Raise the cutting unit so that the wheels are off of the floor. Block the cutting unit so that it cannot accidentally fall.
2. Remove the tensioning cap, spacer(s), and thrust washer from the top of the castor spindle.
3. Pull the castor spindle out of the mounting tube. Allow the thrust washer and spacer(s) to remain on the bottom of the spindle.
4. Insert a pin punch into the top or bottom of the mounting tube and drive the bushing out of the tube (Figure 107). Also drive the other bushing out of the tube. Clean the inside of the tubes to remove dirt.

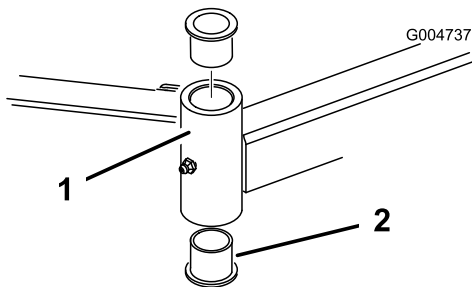

Figure 107

- | | |
|--------------------|-------------|
| 1. Castor arm tube | 2. Bushings |
|--------------------|-------------|

5. Apply grease to the inside and outside of the new bushings. Using a hammer and flat plate, drive the bushings into the mounting tube.
6. Inspect the castor spindle for wear and replace it if it is damaged.
7. Push the castor spindle through the bushings and mounting tube. Slide the thrust washer and spacer(s) onto the spindle. Install the tensioning cap on the castor spindle to retain all parts in place.

Servicing the Castor Wheels and Bearings

Service Interval: Every 800 hours

1. Remove the locknut from the bolt holding the castor wheel assembly between the castor fork (Figure 108) or the castor pivot arm (Figure 109). Grasp the castor wheel and slide the bolt out of the fork or pivot arm.

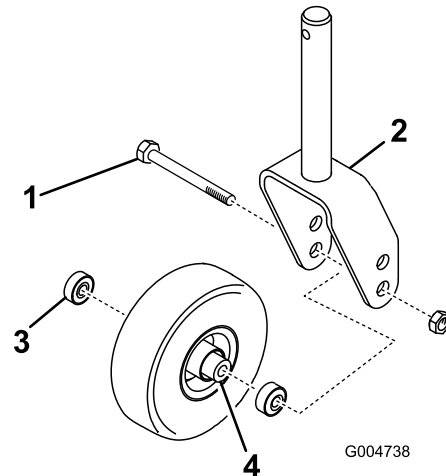

Figure 108

- | | |
|----------------|-------------------|
| 1. Castor bolt | 3. Bearing |
| 2. Castor fork | 4. Bearing spacer |

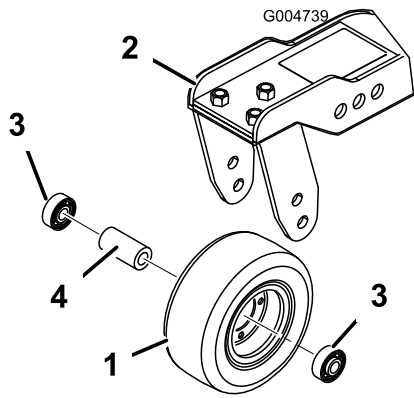

Figure 109

g004739

- | | |
|---------------------|-------------------|
| 1. Castor wheel | 3. Bearing |
| 2. Castor pivot arm | 4. Bearing spacer |

2. Remove the bearing from the wheel hub and allow the bearing spacer to fall out (Figure 108 and Figure 109). Remove the bearing from the opposite side of the wheel hub.
3. Check the bearings, spacer, and inside of the wheel hub for wear. Replace any damaged parts.
4. To assemble the castor wheel, push the bearing into the wheel hub. When installing the bearings, press on the outer race of the bearing.
5. Slide the bearing spacer into the wheel hub. Push the other bearing into the open end of the wheel hub to captivate the bearing spacer inside the wheel hub.
6. Install the castor wheel assembly between the castor fork and secure it in place with the bolt and locknut.

Replacing the Cutting Unit Hinge Covers

The hinge cover prevents debris from escaping at hinge points between cutting units. If cover(s) ever become damaged or worn they must be replaced.

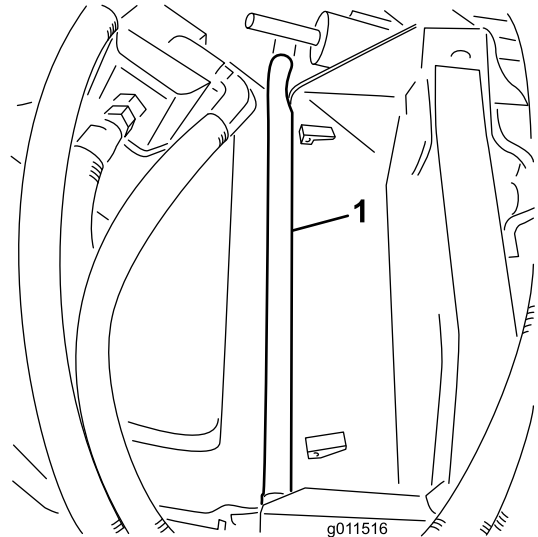

Figure 110

g011516

g011516

Blade Maintenance

Checking for a Bent Blade

After striking a foreign object, inspect the machine for damage and make repairs before restarting and operating the equipment. Torque all the spindle pulley nuts to 176 to 203 N-m (130 to 150 ft-lb).

1. Position the machine on a level surface. Raise the cutting unit, engage the parking brake, put the traction pedal in neutral, put the PTO lever in the Off position, stop the engine, and remove the ignition key. Block the cutting unit to prevent it from accidentally falling.
2. Rotate the blade until the ends face forward and backward (Figure 111). Measure from the inside of the cutting unit to the cutting edge at the front of the blade. Remember this dimension.

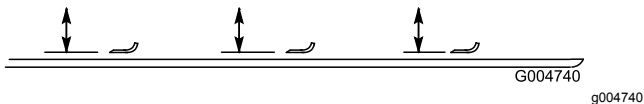

Figure 111

3. Rotate the opposite end of the blade forward. Measure between the cutting unit and cutting edge of the blade at the same position as in step 2. The difference between the dimensions obtained in steps 2 and 3 must not exceed 3 mm (1/8 inch). If the dimension exceeds 3 mm (1/8 inch), the blade is bent and must be replaced; refer to Removing and Installing the Cutter Blade.

Removing and Installing the Cutter Blade(s)

The blade must be replaced if a solid object is hit, the blade is out of balance, or if the blade is bent. Always use genuine Toro replacement blades to be sure of safety and optimum performance. Never use replacement blades made by other manufacturers because they could be dangerous.

1. Raise the cutting unit to the highest position, engage the parking brake, stop the engine, and remove the ignition key. Block the cutting unit to prevent it from accidentally falling.
2. Grasp the end of the blade using a rag or thickly padded glove. Remove the blade bolt, anti-scalp cup, and blade from the spindle shaft (Figure 112).
3. Install the blade, anti-scalp cup, and blade bolt. Tighten the blade bolt to 115 to 149 N-m (85 to 110 ft-lb).

Important: The curved part of the blade must be pointing toward the inside of the cutting unit to ensure proper cutting.

Note: After striking a foreign object, torque all the spindle pulley nuts to 115 to 149 N-m (85 to 110 ft-lb).

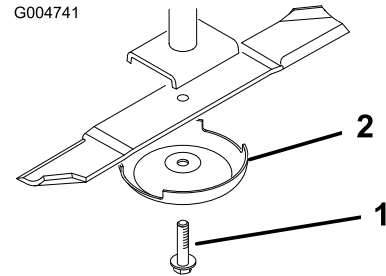

Figure 112

1. Blade bolt
2. Anti-scalp cup

Inspecting and Sharpening the Cutter Blade(s)

⚠ DANGER

A worn or damaged blade can break, and a piece of the blade could be thrown into the operator's or bystander's area, resulting in serious personal injury or death. Trying to repair a damaged blade may result in discontinued safety certification of the product.

- Inspect the blade periodically for wear or damage.
- Never try to straighten a blade that is bent or weld a broken or cracked blade.
- Replace a worn or damaged blade.

Two areas must be considered when checking and servicing the cutter blade—the sail and the cutting edge. Both cutting edges and the sail, which is the turned up portion opposite the cutting edge, contribute to a good quality-of-cut. The sail is important because it lifts the grass up straight, thereby producing an even cut. However, the sail will gradually wear down during operation, and this condition is normal. As the sail wears down, the quality-of-cut will degrade somewhat, although the cutting edges are sharp. The cutting edge of the blade must be sharp so that the grass is cut rather than torn. A dull cutting edge is evident when the tips of the grass appear brown and shredded. Sharpen the cutting edges to correct this condition.

1. Position the machine on a level surface. Raise the cutting unit, engage the parking brake, put the traction pedal in neutral, put the PTO lever in the Off position, stop the engine, and remove the ignition key.
2. Examine the cutting ends of the blade carefully, especially where the flat and curved parts of the blade meet (Figure 113). Since sand and abrasive material can wear away the metal that connects the flat and curved parts of the blade, check the blade before using the mower. If wear is noticed (Figure 113), replace the blade.

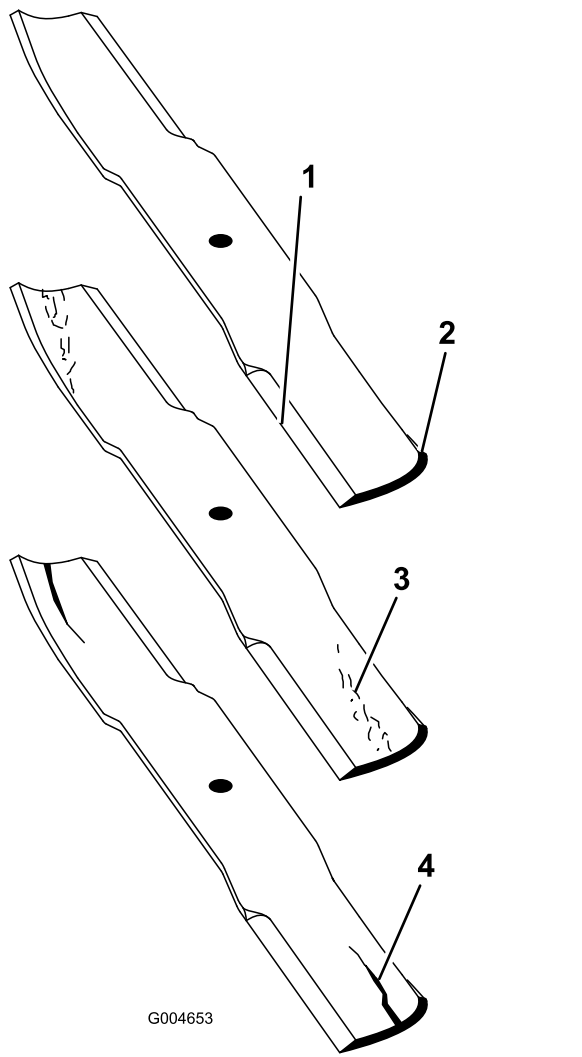

Figure 113

- | | |
|-----------------|----------------------|
| 1. Cutting Edge | 3. Wear/slot Forming |
| 2. Curved Area | 4. Crack |

3. Examine the cutting edges of all of the blades. Sharpen the cutting edges if they are dull or nicked. Sharpen only the top of the cutting edge and maintain the original cutting angle to make sure of sharpness (Figure 114). The blade will remain balanced if the same amount of metal is removed from both cutting edges.

▲ DANGER

If the blade is allowed to wear, a slot will form between the sail and flat part of the blade. Eventually a piece of the blade may break off and be thrown from under the housing, possibly resulting in serious injury to you or bystanders.

- Inspect the blade periodically for wear or damage.
- Never try to straighten a blade that is bent or weld a broken or cracked blade.
- Replace a worn or damaged blade.

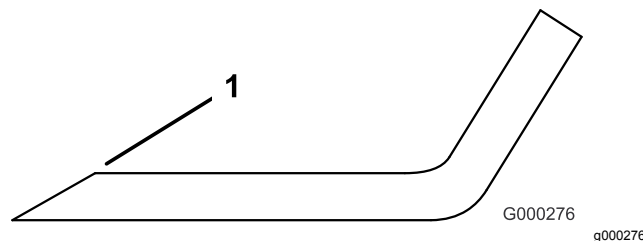

Figure 114

1. Sharpen at original angle

Note: Remove the blades and sharpen them on a grinder. After sharpening the cutting edges, install the blade with the anti-scalp cup and blade bolt; refer to Removing and Installing the Cutter Blade(s).

Correcting Cutting Unit Mismatch

If there is mismatch between the blades, on a single cutting unit, the grass will appear streaked when it is cut. This problem can be corrected by making sure that the blades are straight and all of the blades are cutting on the same plane.

1. Using a 1 meter (3 foot) long carpenters level, find a level surface on the shop floor.
2. Raise the height-of-cut to the highest position; refer to Adjusting the Height-Of-Cut.
3. Lower the cutting unit onto the flat surface. Remove the covers from the top of the cutting unit.
4. Loosen the flange nut securing the idler pulley to release the belt tension.
5. Rotate the blades until the ends face forward and backward. Measure from the floor to the

front tip of the cutting edge. Remember this dimension. Then rotate the same blade so that the opposite end is forward, and measure again. The difference between the dimensions must not exceed 3 mm (1/8 inch). If the dimension exceeds 3 mm (1/8 inch), replace the blade because it is bent. Make sure to measure all of the blades.

6. Compare the measurements of the outer blades with the center blade. The center blade must not be more than 10 mm (3/8 inch) lower than the outer blades. If the center blade is more than 10 mm (3/8 inch) lower than the outer blades, proceed to step 7 and add shims between the spindle housing and the bottom of the cutting unit.
7. Remove the bolts, flat washers, lock washers, and nuts from the outer spindle in the area where the shims must be added. To raise or lower the blade, add a shim, Part No. 3256-24, between the spindle housing and the bottom of the cutting unit. Continue to check the alignment of the blades and add shims until the tips of the blades are within the required dimension.

Important: Do not use more than three shims at any one hole location. Use decreasing numbers of shims in adjacent holes if more than one shim is added to any one hole location.

8. Adjust the idler pulley and install the belt covers.

Cab Maintenance

Cleaning the Cab Air Filters

Service Interval: Every 250 hours (Replace them if they are torn or excessively dirty.)

1. Remove the thumb screws and grates from over both the in-cab and rear cab air filters (Figure 115).

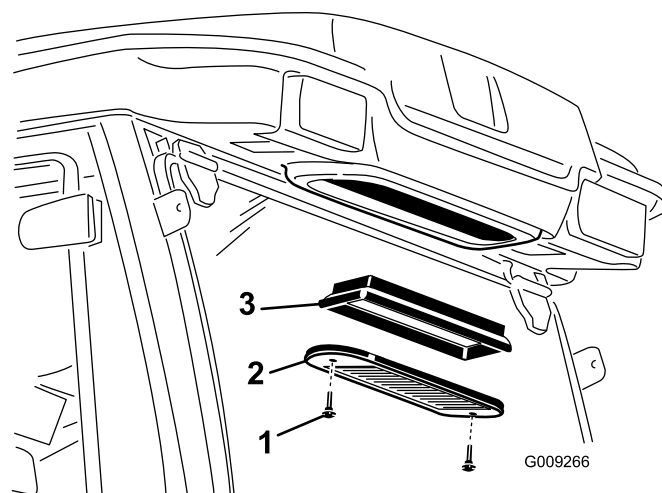
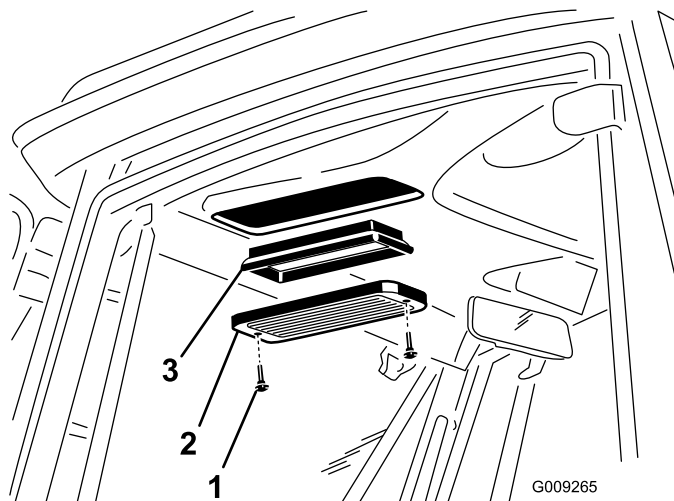

Figure 115

- | | |
|----------------|---------------|
| 1. Thumb screw | 3. Air filter |
| 2. Grate | |

2. Clean the filters by blowing clean, oil free, compressed air through them.

Important: If either filter has a hole, tear, or other damage, replace it.

3. Install the filters and grate, securing them with the thumb screws.

Cleaning the Air Conditioning Coil

Service Interval: Every 250 hours (Clean more frequently in extremely dusty or dirty conditions)

1. Stop the engine and remove the key.
2. Remove the (4) screws securing the fan and the condenser cover to the fan mount (Figure 116).
3. Carefully lift the fan out of the condenser cover.

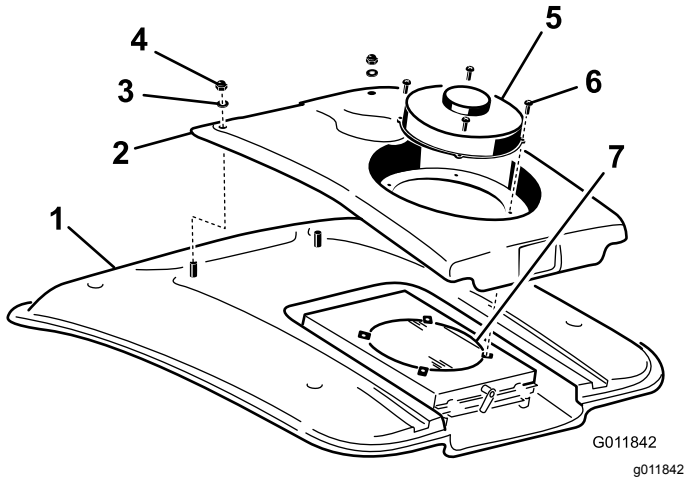

Figure 116

- | | |
|--------------------|-------------------------------|
| 1. Cabin roof | 5. Fan |
| 2. Condenser cover | 6. Screw |
| 3. Washer | 7. Air conditioning condenser |
| 4. Nut | |

4. Remove the two nuts and washers securing the front of the condenser cover to the cab roof (Figure 116).
5. Unplug the fan wire connectors located between the cover and roof.
6. Remove the fan and the cover.
7. Remove and clean the A/C Condenser Screen. Refer to Cleaning the A/C Condenser Screen.
8. Clean the air conditioning condenser thoroughly with compressed air (Figure 116).
9. Replace the A/C Condenser Screen.
10. Replace the condenser cover and fan. Make sure to connect the fan wires before securing the condenser cover.

Cleaning the A/C Condenser Screen

Service Interval: Every 50 hours (Clean more frequently in extremely dusty or dirty conditions)

1. Stop the engine and remove the key.
2. On the rear of the fan mount, rotate the latch to the side (Figure 117).

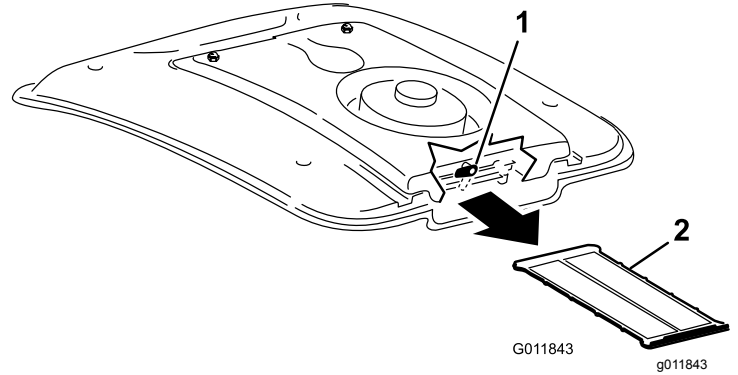

Figure 117

- | | |
|----------|---------------|
| 1. Latch | 2. A/C screen |
|----------|---------------|
3. Slide the A/C screen out from under the air conditioning coil (Figure 117).
 4. Clean the screen thoroughly with compressed air (Figure 117).
 5. Slide the screen into the channels under the air conditioning coil and rotate the latch downward.

Storage

Preparing for Seasonal Storage

Traction Unit

1. Thoroughly clean the traction unit, cutting units, and the engine.
2. Check the tire pressure; refer to Checking the Tire Pressure.
3. Check all fasteners for looseness; tighten as necessary.
4. Grease or oil all grease fittings and pivot points. Wipe up any excess lubricant.
5. Lightly sand and use touch-up paint on painted areas that are scratched, chipped, or rusted. Repair any dents in the metal body.
6. Service the battery and cables as follows:
 - A. Remove the battery terminals from the battery posts.
 - B. Clean the battery, terminals, and posts with a wire brush and baking soda solution.
 - C. Coat the cable terminals and battery posts with Grafo 112X skin-over grease (Toro Part No. 505-47) or petroleum jelly to prevent corrosion.
 - D. Slowly recharge the battery every 60 days for 24 hours to prevent lead sulfation of the battery.

Engine

1. Drain the engine oil from the oil pan and install the drain plug.
2. Remove and discard the oil filter. Install a new oil filter.
3. Refill the oil pan with motor oil.
4. Start the engine and run it at idle speed for approximately two minutes.
5. Stop the engine.
6. Flush the fuel tank with fresh, clean diesel fuel.
7. Secure all of the fuel system fittings.
8. Thoroughly clean and service the air cleaner assembly.
9. Seal the air cleaner inlet and the exhaust outlet with weatherproof tape.
10. Check the anti freeze protection and add a 50/50 solution of water and ethylene glycol anti-freeze as needed for the expected minimum temperature in your area.

Schematics

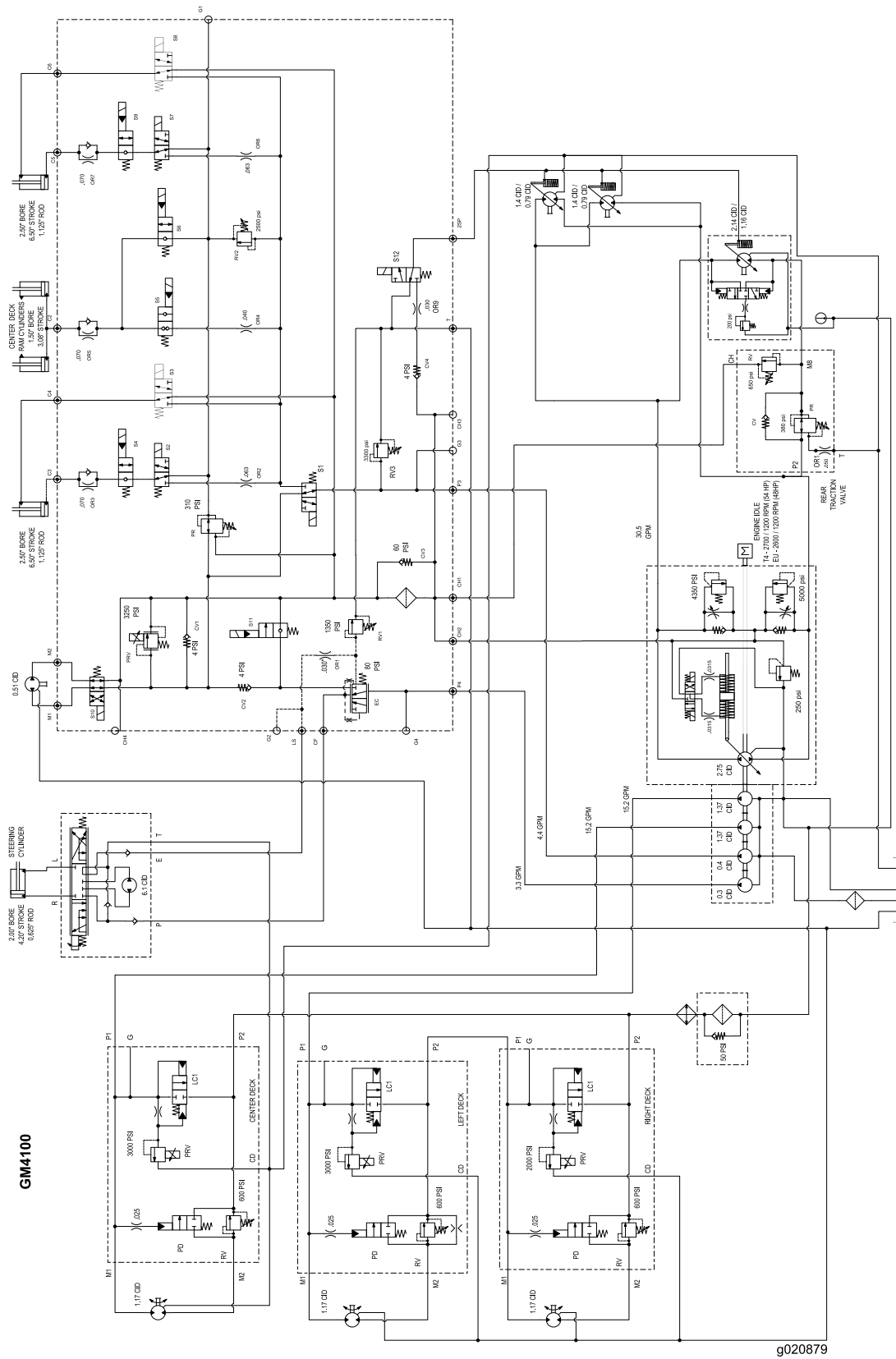

Hydraulic Schematic (Rev. B)

g020879



The Toro Total Coverage Guarantee

A Limited Warranty

Conditions and Products Covered

The Toro Company and its affiliate, Toro Warranty Company, pursuant to an agreement between them, jointly warrant your Toro Commercial product ("Product") to be free from defects in materials or workmanship for two years or 1500 operational hours*, whichever occurs first. This warranty is applicable to all products with the exception of Aerators (refer to separate warranty statements for these products). Where a warrantable condition exists, we will repair the Product at no cost to you including diagnostics, labor, parts, and transportation. This warranty begins on the date the Product is delivered to the original retail purchaser.

* Product equipped with an hour meter.

Instructions for Obtaining Warranty Service

You are responsible for notifying the Commercial Products Distributor or Authorized Commercial Products Dealer from whom you purchased the Product as soon as you believe a warrantable condition exists. If you need help locating a Commercial Products Distributor or Authorized Dealer, or if you have questions regarding your warranty rights or responsibilities, you may contact us at:

Toro Commercial Products Service Department
Toro Warranty Company
8111 Lyndale Avenue South
Bloomington, MN 55420-1196
952-888-8801 or 800-952-2740
E-mail: commercial.warranty@toro.com

Owner Responsibilities

As the Product owner, you are responsible for required maintenance and adjustments stated in your *Operator's Manual*. Failure to perform required maintenance and adjustments can be grounds for disallowing a warranty claim.

Items and Conditions Not Covered

Not all product failures or malfunctions that occur during the warranty period are defects in materials or workmanship. This warranty does not cover the following:

- Product failures which result from the use of non-Toro replacement parts, or from installation and use of add-on, or modified non-Toro branded accessories and products. A separate warranty may be provided by the manufacturer of these items.
- Product failures which result from failure to perform recommended maintenance and/or adjustments. Failure to properly maintain your Toro product per the Recommended Maintenance listed in the *Operator's Manual* can result in claims for warranty being denied.
- Product failures which result from operating the Product in an abusive, negligent, or reckless manner.
- Parts subject to consumption through use unless found to be defective. Examples of parts which are consumed, or used up, during normal Product operation include, but are not limited to, brake pads and linings, clutch linings, blades, reels, rollers and bearings (sealed or greasable), bed knives, spark plugs, castor wheels and bearings, tires, filters, belts, and certain sprayer components such as diaphragms, nozzles, and check valves, etc.
- Failures caused by outside influence. Conditions considered to be outside influence include, but are not limited to, weather, storage practices, contamination, use of unapproved fuels, coolants, lubricants, additives, fertilizers, water, or chemicals, etc.
- Failure or performance issues due to the use of fuels (e.g. gasoline, diesel, or biodiesel) that do not conform to their respective industry standards.

Countries Other than the United States or Canada

Customers who have purchased Toro products exported from the United States or Canada should contact their Toro Distributor (Dealer) to obtain guarantee policies for your country, province, or state. If for any reason you are dissatisfied with your Distributor's service or have difficulty obtaining guarantee information, contact the Toro importer.

- Normal noise, vibration, wear and tear, and deterioration.
- Normal "wear and tear" includes, but is not limited to, damage to seats due to wear or abrasion, worn painted surfaces, scratched decals or windows, etc.

Parts

Parts scheduled for replacement as required maintenance are warranted for the period of time up to the scheduled replacement time for that part. Parts replaced under this warranty are covered for the duration of the original product warranty and become the property of Toro. Toro will make the final decision whether to repair any existing part or assembly or replace it. Toro may use remanufactured parts for warranty repairs.

Deep Cycle and Lithium-Ion Battery Warranty:

Deep cycle and Lithium-Ion batteries have a specified total number of kilowatt-hours they can deliver during their lifetime. Operating, recharging, and maintenance techniques can extend or reduce total battery life. As the batteries in this product are consumed, the amount of useful work between charging intervals will slowly decrease until the battery is completely worn out. Replacement of worn out batteries, due to normal consumption, is the responsibility of the product owner. Battery replacement may be required during the normal product warranty period at owner's expense. Note: (Lithium-Ion battery only): A Lithium-Ion battery has a part only prorated warranty beginning year 3 through year 5 based on the time in service and kilowatt hours used. Refer to the *Operator's Manual* for additional information.

Maintenance is at Owner's Expense

Engine tune-up, lubrication, cleaning and polishing, replacement of filters, coolant, and completing recommended maintenance are some of the normal services Toro products require that are at the owner's expense.

General Conditions

Repair by an Authorized Toro Distributor or Dealer is your sole remedy under this warranty.

Neither The Toro Company nor Toro Warranty Company is liable for indirect, incidental or consequential damages in connection with the use of the Toro Products covered by this warranty, including any cost or expense of providing substitute equipment or service during reasonable periods of malfunction or non-use pending completion of repairs under this warranty. Except for the Emissions warranty referenced below, if applicable, there is no other express warranty. All implied warranties of merchantability and fitness for use are limited to the duration of this express warranty.

Some states do not allow exclusions of incidental or consequential damages, or limitations on how long an implied warranty lasts, so the above exclusions and limitations may not apply to you. This warranty gives you specific legal rights, and you may also have other rights which vary from state to state.

Note regarding engine warranty:

The Emissions Control System on your Product may be covered by a separate warranty meeting requirements established by the U.S. Environmental Protection Agency (EPA) and/or the California Air Resources Board (CARB). The hour limitations set forth above do not apply to the Emissions Control System Warranty. Refer to the Engine Emission Control Warranty Statement supplied with your product or contained in the engine manufacturer's documentation for details