

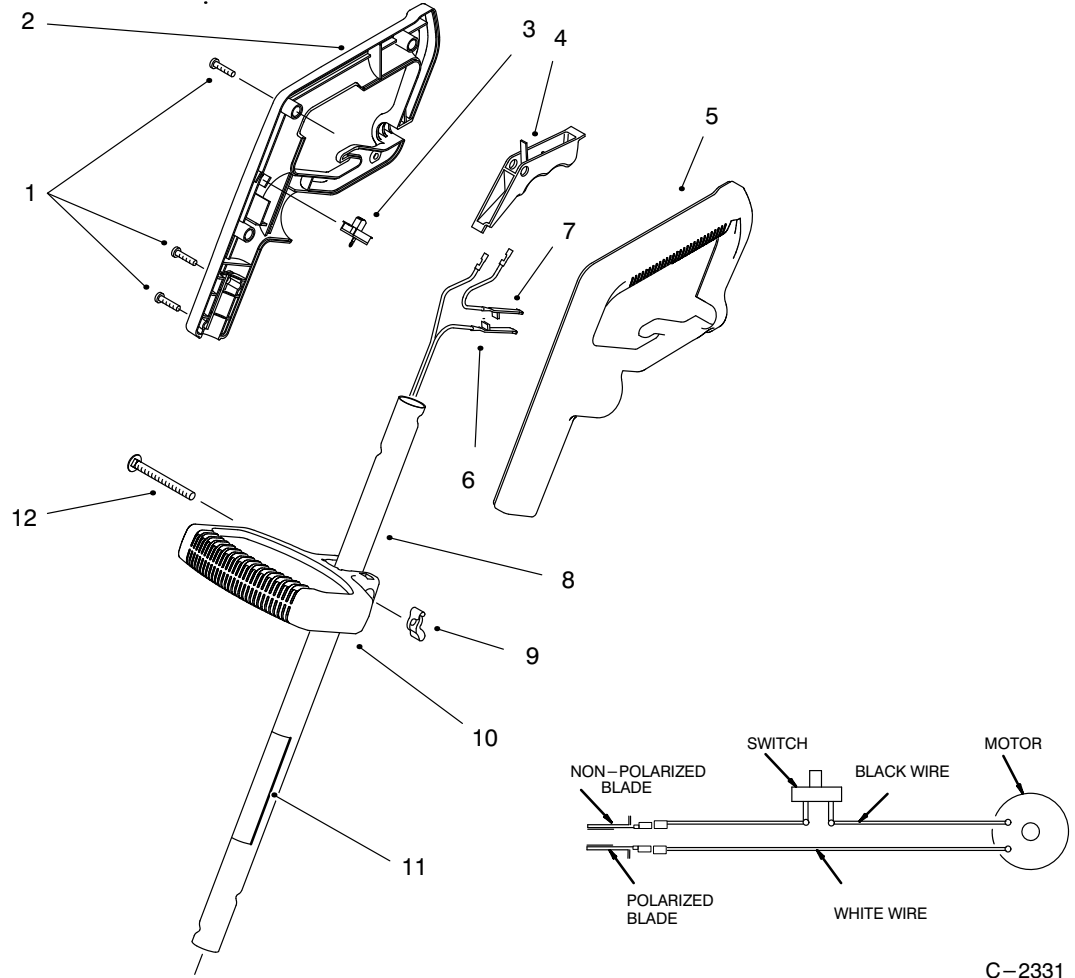

MODEL NO. 51324-8900001 & UP
 MODEL NO. 51332-8900001 & UP

PARTS
 CATALOG

12" ELECTRIC TRIMMER



C-2331

HANDLE ASSEMBLY

Ref. No.	Part No.	Description	No. Used
1	94-4496	Screw - Pan Hd Tapping	6
2	98-1839	Grip - Hand R.H.	1
3	73-5600	Switch - Single Speed	1
4	73-8170	Trigger	1
5	98-1840	Grip - Hand L.H.	1
6	98-1849	Harness - Wire	1
7	98-1837	Jumper Wire Asm	1

Ref. No.	Part No.	Description	No. Used
8	98-7183	Tube Assembly (Incl. Ref. #11)	1
9	32103-30	Nut - Wing	1
10	73-8310	Handle - Mid	1
11	98-7184	Decal - Safety	1
12	73-8740	Screw - Carriage	1

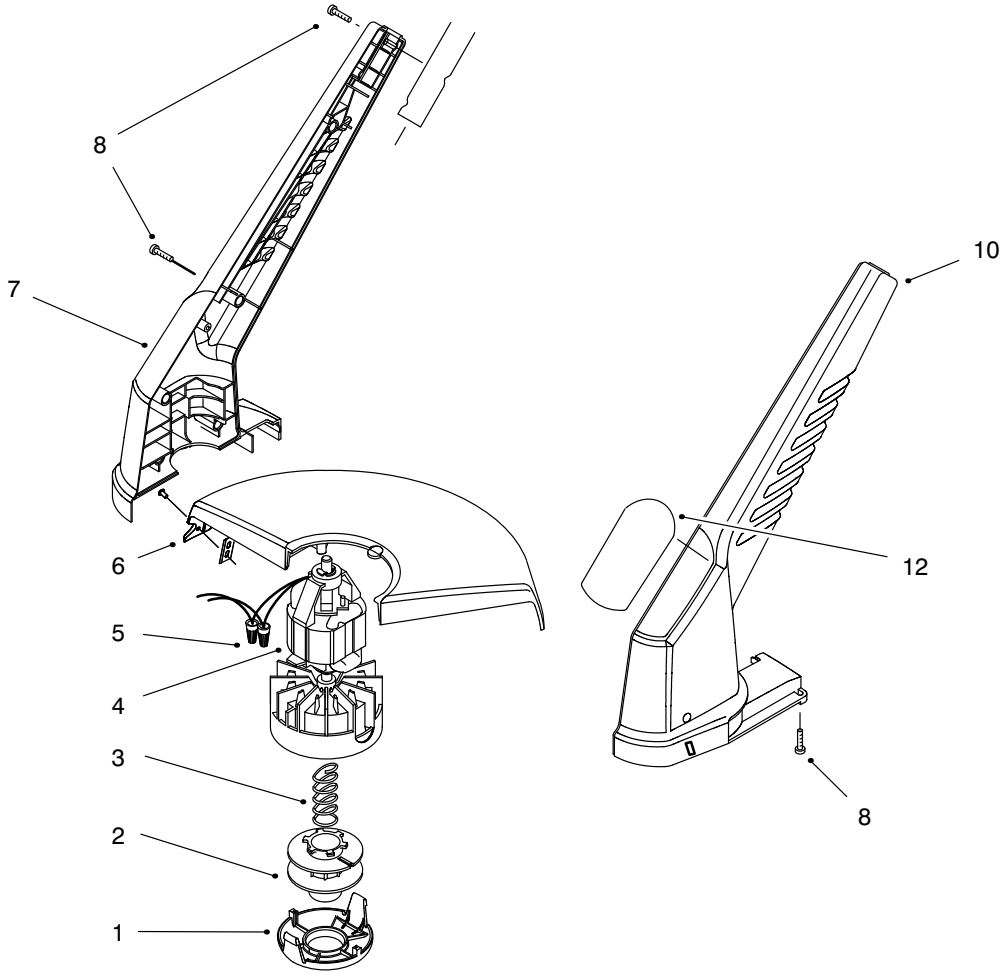

C-2330

MOTOR & HOUSING ASSEMBLY

Ref. No.	Part No.	Description	No. Used
1	73-8200	Cap	1
2	73-8190	Spool	1
3	73-8220	Spring	1
4	73-9051	Motor Assembly	1
5	73-6570	Connector - Wire Nut	2
6	73-9091	Shield Asm.	1
7	98-1841	Housing R.H.	1

Ref. No.	Part No.	Description	No. Used
8	94-4496	Screw - Pan Hd. Tapping	8
10	98-1842	Housing L.H.	1
12	98-3549	Decal - 12" Trimmer	1
*	88175	Spool & Line Assembly (Whole Goods) (Incl. Ref. #2 and 30 ft of .065 line)	1

*Not Illustrated