



Count on it.

Operator's Manual

**Z Master[®] 8000 Series Riding
Mower**
with 42in Cutting Unit

Model No. 74315—Serial No. 40000000 and Up

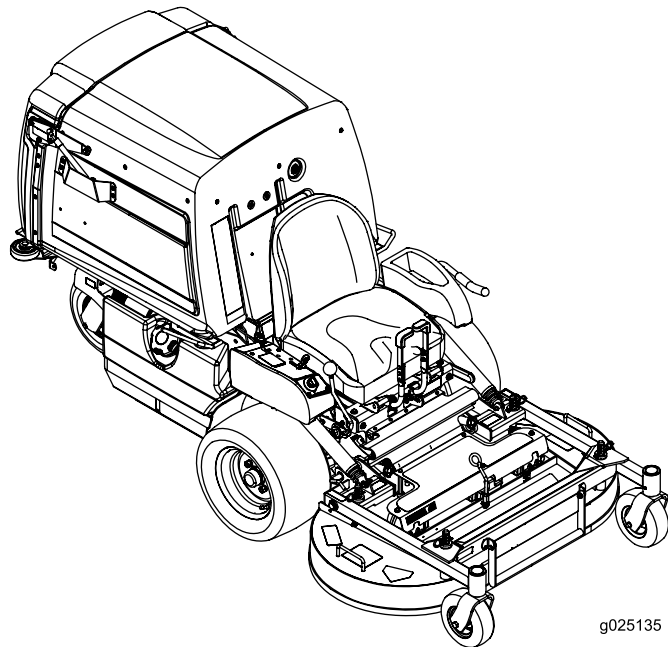

g025135



⚠ WARNING

CALIFORNIA Proposition 65 Warning

This product contains a chemical or chemicals known to the State of California to cause cancer, birth defects, or reproductive harm.

The engine exhaust from this product contains chemicals known to the State of California to cause cancer, birth defects, or other reproductive harm.

This spark ignition system complies with Canadian ICES-002

It is a violation of California Public Resource Code Section 4442 or 4443 to use or operate the engine on any forest-covered, brush-covered, or grass-covered land unless the engine is equipped with a spark arrester, as defined in Section 4442, maintained in effective working order or the engine is constructed, equipped, and maintained for the prevention of fire.

Please refer to the engine manufacturer's information included with the machine.

Introduction

This rotary-blade, riding lawn mower is intended to be used by residential homeowners or professional, hired operators. It is designed primarily for cutting grass on well-maintained lawns on residential or commercial properties. It is not designed for cutting brush or for agricultural uses.

Read this information carefully to learn how to operate and maintain your product properly and to avoid injury and product damage. You are responsible for operating the product properly and safely.

You may contact Toro directly at www.Toro.com for product safety and operation training materials, accessory information, help finding a dealer, or to register your product.

Whenever you need service, genuine Toro parts, or additional information, contact an Authorized Service Dealer or Toro Customer Service and have the model and serial numbers of your product ready. [Figure 1](#) identifies the location of the model and serial numbers on the product. Write the numbers in the space provided.

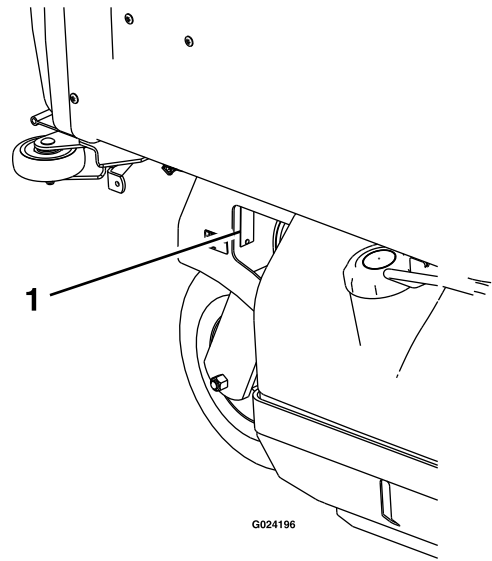

Figure 1

1. Model and serial number location

Model No. _____

Serial No. _____

This manual identifies potential hazards and has safety messages identified by the safety-alert symbol ([Figure 2](#)), which signals a hazard that may cause serious injury or death if you do not follow the recommended precautions.



Figure 2

1. Safety-alert symbol

This manual uses 2 words to highlight information. **Important** calls attention to special mechanical information and **Note** emphasizes general information worthy of special attention.

Contents

| | | | |
|--|----|---|----|
| Safety | 4 | Electrical System Safety | 38 |
| General Safety | 4 | Servicing the Battery | 38 |
| Slope Indicator | 5 | Servicing the Fuses | 40 |
| Safety and Instructional Decals | 6 | Adjusting the Safety Switches | 40 |
| Product Overview | 13 | Drive System Maintenance | 41 |
| Controls | 13 | Adjusting the Tracking | 41 |
| Specifications | 14 | Checking the Tire Pressure | 41 |
| Before Operation | 15 | Checking the Wheel-Lug Nuts | 41 |
| Before Operation Safety | 15 | Checking the Wheel-Hub Nuts | 41 |
| Recommended Fuel | 15 | Adjusting the Caster-Pivot Bearings | 41 |
| Using Stabilizer/Conditioner | 16 | Cooling System Maintenance | 42 |
| Filling the Fuel Tank | 16 | Cleaning the Engine Screen and Engine Oil | |
| Checking the Engine-Oil Level | 16 | Cooler | 42 |
| Breaking in a New Machine | 16 | Servicing the Engine-Oil Cooler | 42 |
| Think Safety First | 16 | Cleaning the Engine Cooling Fins and | |
| Raising the Mower Deck into the Service | | Shrouds | 42 |
| Position | 17 | Checking and Cleaning the Hydraulic | |
| Lowering the Mower Deck to the Operating | | Pumps | 43 |
| Position | 18 | Brake Maintenance | 43 |
| Adjusting the Fill Reduction System (FRS) | | Adjusting the Parking Brake | 43 |
| Baffles | 18 | Belt Maintenance | 45 |
| The Safety-Interlock System | 19 | Inspecting the Belts | 45 |
| During Operation | 20 | Replacing the PTO Belts | 45 |
| During Operation Safety | 20 | Replacing the Pump-Drive Belt | 46 |
| Operating the Throttle | 21 | Adjusting the Belt Guides | 46 |
| Operating the Ignition Switch | 21 | Controls System Maintenance | 47 |
| Operating the PTO-Engagement Lever | 21 | Adjusting the Reverse-Stop Rod | 47 |
| Operating the Parking Brake | 22 | Adjusting the Speed-Control Lever | |
| Starting and Shutting Off the Engine | 22 | Tension | 47 |
| Driving Forward or Backward | 24 | Adjusting the Speed-Control Linkage | 48 |
| Adjusting the Height of Cut | 24 | Aligning the PTO-Drive Pulley | 48 |
| Stopping the Machine | 25 | Aligning the Pump-Drive Pulley | 49 |
| Emptying the Hopper | 25 | Adjusting the PTO Brake Spring | 49 |
| Operating Tips | 25 | Adjusting the Hopper Door | 50 |
| After Operation | 26 | Adjusting the Locking-Pin Stop on the Mower | |
| After Operation Safety | 26 | Deck | 50 |
| Clearing the Hopper Screen | 26 | Hydraulic System Maintenance | 51 |
| Using the Drive-Wheel Release Valves | 26 | Hydraulic System Safety | 51 |
| Transporting the Machine | 27 | Servicing the Hydraulic System | 51 |
| Loading the Machine | 27 | Mower Deck Maintenance | 52 |
| Maintenance | 28 | Leveling the Mower Deck | 52 |
| Recommended Maintenance Schedule(s) | 28 | Servicing the Cutting Blades | 53 |
| Pre-Maintenance Procedures | 29 | Removing the Mower Deck | 56 |
| Maintenance and Storage Safety | 29 | Installing the Mower Deck | 57 |
| Lubrication | 30 | Adjusting the Locking-Pin Stop on the Mower | |
| Lubricating the Machine | 30 | Deck | 57 |
| Engine Maintenance | 33 | Cleaning | 58 |
| Engine Safety | 33 | Cleaning under the Mower | 58 |
| Servicing the Air Cleaner | 33 | Cleaning Debris from the Machine | 58 |
| Servicing the Engine Oil | 34 | Disposing of Waste | 58 |
| Servicing the Spark Plugs | 36 | Storage | 58 |
| Checking the Spark Arrester | 37 | Cleaning and Storage | 58 |
| Fuel System Maintenance | 37 | Troubleshooting | 60 |
| Replacing the Fuel Filter | 37 | Schematics | 62 |
| Servicing the Fuel Tank | 38 | | |
| Electrical System Maintenance | 38 | | |

Safety

This machine has been designed in accordance to the ANSI B71.4-2012 specification of the American National Standards Institute with the addition of the optional ROPS accessory.

General Safety

This product is capable of amputating hands and feet and of throwing objects. Always follow all safety instructions to avoid serious personal injury.

Using this product for purposes other than its intended use could prove dangerous to you and bystanders.

- Read and understand the contents of this *Operator's Manual* before you start the engine. Ensure that everyone using this product knows how to use it and understands the warnings.
- Do not put your hands or feet near moving components of the machine.
- Do not operate the machine without all guards and other safety protective devices in place and working on the machine.
- Keep clear of any discharge opening. Keep bystanders a safe distance away from the machine.
- Keep children out of the operating area. Never allow children to operate the machine.
- Stop the machine and shut off the engine before servicing, fueling, or unclogging the machine.

Improperly using or maintaining this machine can result in injury. To reduce the potential for injury, comply with these safety instructions and always pay attention to the safety-alert symbol, which means Caution, Warning, or Danger—personal safety instruction. Failure to comply with these instructions may result in personal injury or death.

You can find additional items of safety information in their respective sections throughout this manual.

Slope Indicator

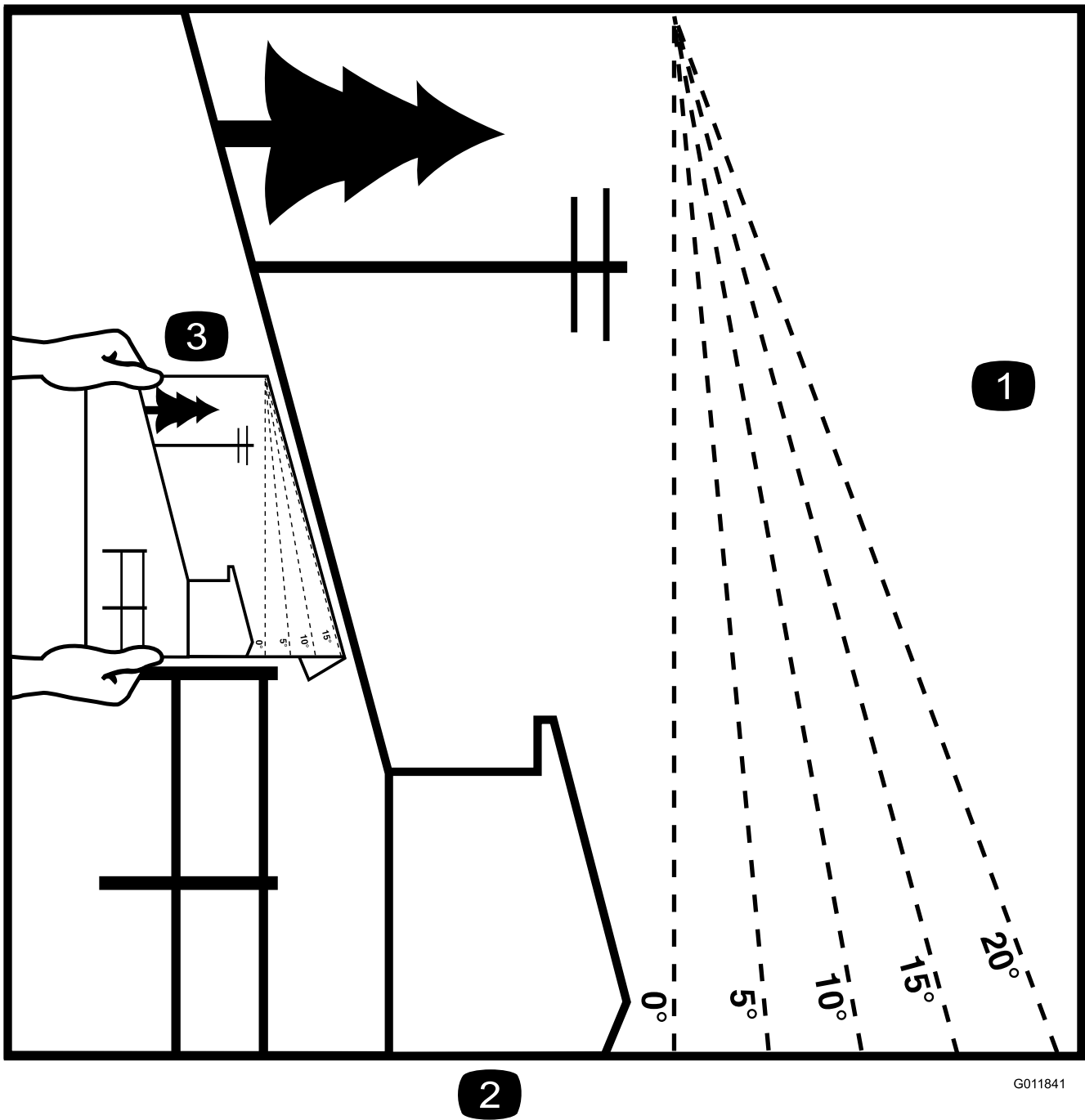

G011841

g011841

Figure 3

This page may be copied for personal use.

1. The maximum slope you can safely operate the machine on is **15 degrees**. Use the slope chart to determine the degree of slope of hills before operating. **Do not operate this machine on a slope greater than 15 degrees.** Fold along the appropriate line to match the recommended slope.
2. Align this edge with a vertical surface, a tree, building, fence pole, etc.
3. Example of how to compare slope with folded edge

Safety and Instructional Decals



Safety decals and instructions are easily visible to the operator and are located near any area of potential danger. Replace any decal that is damaged or missing.

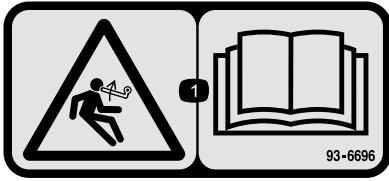

93-6696

decal93-6696

1. Stored energy hazard—read the *Operator's Manual*.

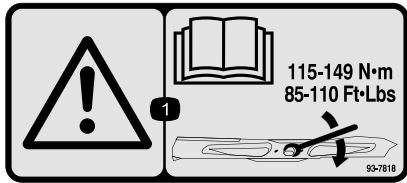

93-7818

decal93-7818

1. Warning—read the *Operator's Manual* for instructions on torquing the blade bolt/nut to 115-149 N•m (85-110 ft-lb).

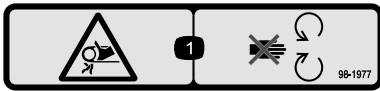

98-1977

decal98-1977

1. Entanglement hazard, belt—stay away from moving parts.



106-5517

decal106-5517

1. Warning—do not touch the hot surface.

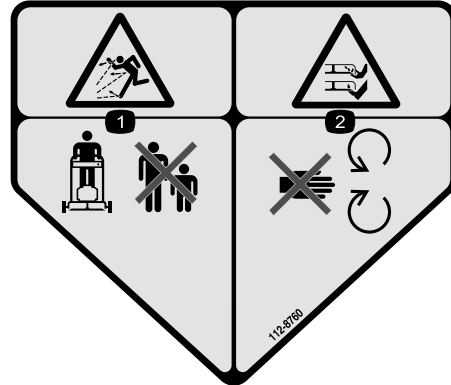

112-8760

decal112-8760

1. Thrown object hazard—keep bystanders a safe distance away from the machine.
2. Cutting/dismemberment of hand or foot—stay away from moving parts.

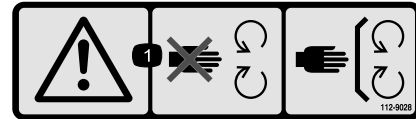

112-9028

decal112-9028

1. Warning—stay away from moving parts; keep all guards in place.

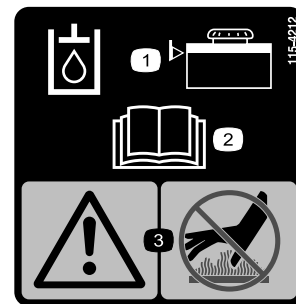

115-4212

decal115-4212

1. Hydraulic fluid level
2. Read the *Operator's Manual*.
3. Warning—do not touch the hot surface.

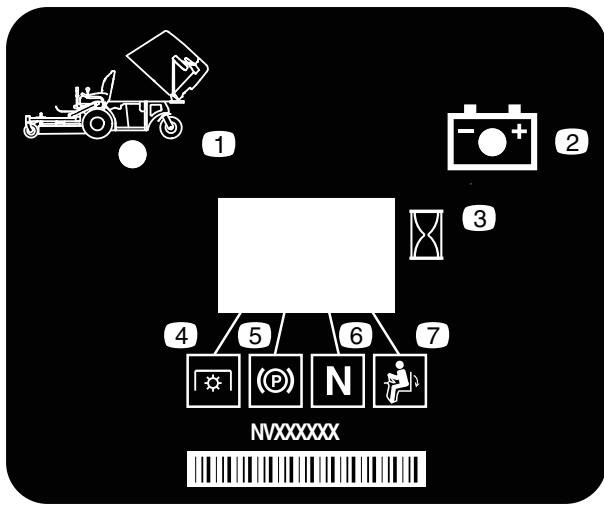

116-8813

decal116-8813

- | | |
|------------------------|-----------------------------|
| 1. Hopper up indicator | 5. Parking brake |
| 2. Battery | 6. Neutral |
| 3. Hour meter | 7. Operator presence switch |
| 4. PTO | |

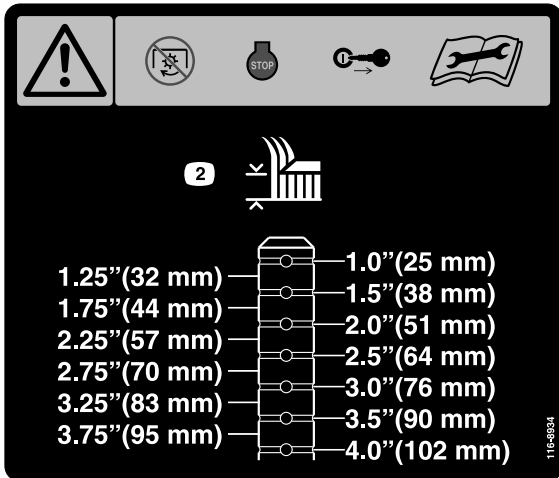

116-8934

decal116-8934

- | | |
|--|------------------|
| 1. Warning—disengage blade clutch, shut off engine, and remove key before making adjustments, servicing, or cleaning deck. | 2. Height of cut |
|--|------------------|

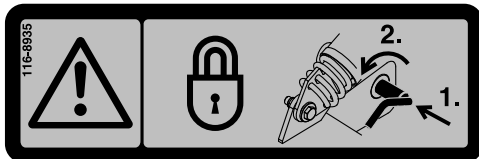

116-8935

decal116-8935

- Warning folding deck hazard—lock the pivot joint by pushing inward and rotating toward the front of the deck.

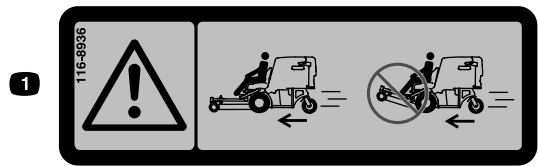

116-8936

decal116-8936

- Danger—do not operate with deck in tilt-up position.

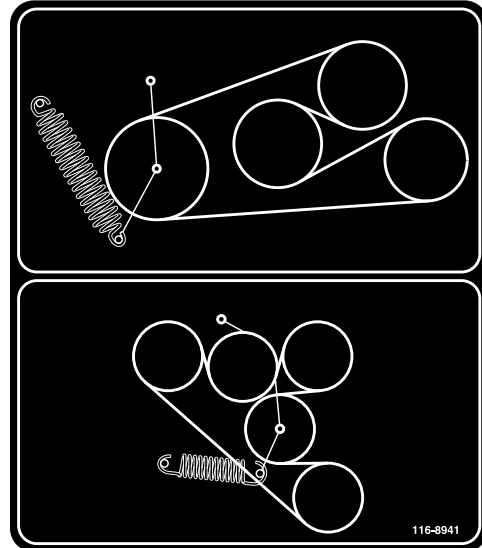

116-8941

decal116-8941

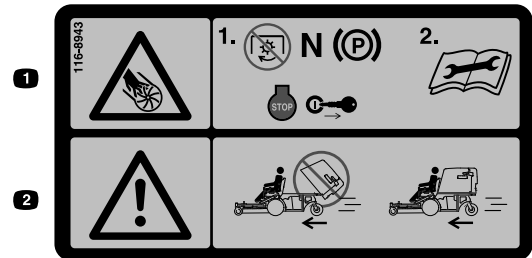

116-8943

decal116-8943

- Rotating blades hazard—disengage the PTO, move the speed-control lever to neutral, engage the parking brake, shut off the engine, and remove the key before leaving the operator's position. Read the instructions before servicing or performing maintenance.
- Danger—do not operate with mower hopper in raised position

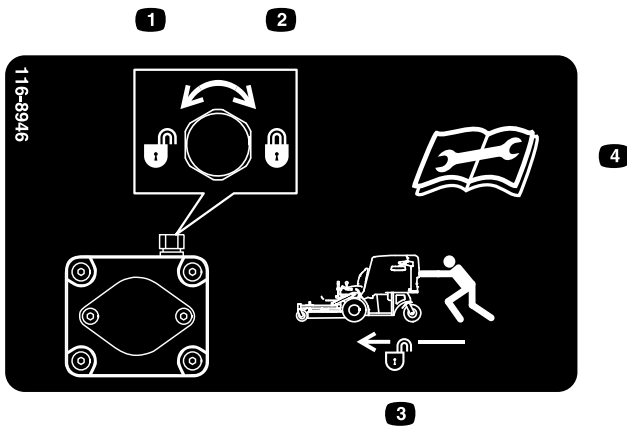

116-8946

decal116-8946

1. Rotate counterclockwise to release
2. Rotate clockwise to lock
3. Unlock to push the machine
4. Read the instructions before servicing or performing maintenance.

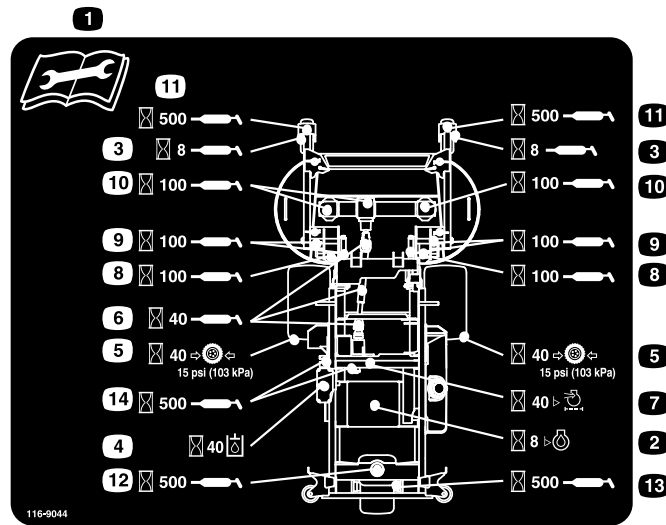

116-9044

decal116-9044

1. Read the *Operator's Manual* before performing any maintenance.
2. Check the engine oil every 8 hours.
3. Grease the front caster wheel bearings every 8 hours.
4. Check the hydraulic fluid level every 40 hours (only use recommended hydraulic fluid).
5. Check the tire pressure every 40 hours.
6. Grease the deck drive PTO every 40 hours.
7. Check the air cleaner every 40 hours.
8. Grease the deck-lock mechanism every 100 hours.
9. Grease the deck pivots every 100 hours.
10. Check the gearbox oil every 100 hours (use only Mobil 1 75W-90 gear oil).
11. Grease the front caster pivots every 500 hours.
12. Grease the rear caster pivot every 500 hours.
13. Grease the rear caster wheel every 500 hours.
14. Grease the belt idlers every 500 hours.

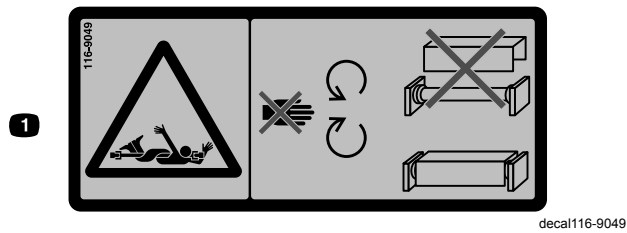

116-9049

1. Rotating driveline hazard—keep all driveline shields in place. Securely attach both ends of the driveline.

CALIFORNIA SPARK ARRESTER WARNING
 Operation of this equipment may create sparks that can start fires around dry vegetation. A spark arrester may be required. The operator should contact local fire agencies for laws or regulations relating to fire prevention requirements.

117-2718

117-2718

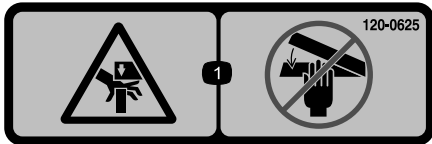

120-0625

1. Pinch point, hand—keep your hands away.

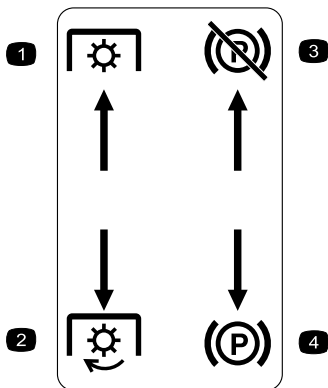

Molded in Left Console

- | | |
|------------------|-----------------------|
| 1. PTO—disengage | 3. Park brake—release |
| 2. PTO—engage | 4. Park brake—engage |

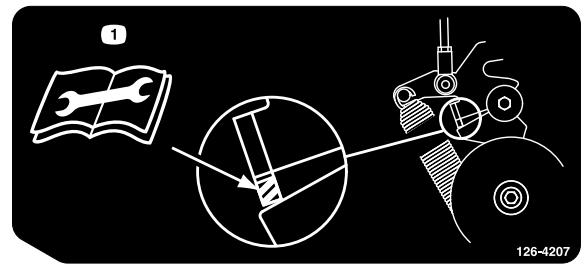

126-4207

1. Refer to the *Operator's Manual* for adjustment procedure. When the PTO is engaged, idler arm position must be in hatched area; otherwise adjust it.

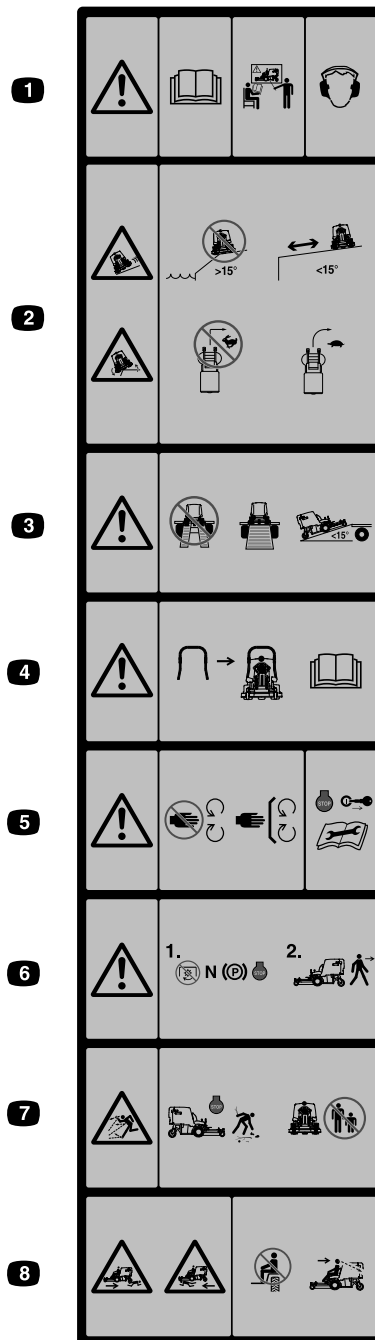

Molded into Front of Hopper

decal126-4158

1. Warning—Read the *Operator's Manual*. Do not operate this machine unless you are trained. Wear hearing protection.
2. Sliding, tipping hazard—Do not use the machine near drop-offs with slopes greater than 15 degrees, use the machine a safe distance away from drop-offs on slopes less than 15 degrees; Do not turn sharply while traveling fast, drive slowly when turning.
3. Warning—Do not use dual ramps, use 1-piece ramps when transporting machine; Do not use ramps with inclination greater than 15 degrees.
4. A rollbar is available; use it for areas where there are slopes, drop-offs, or water.
5. Warning—Stay away from moving parts; keep all guards in place. Shut off the engine and remove the key before adjusting, servicing, or cleaning.
6. Warning—Disengage PTO, move the speed-control lever to NEUTRAL position, engage the parking brake, and shut off the engine before leaving the operator's position.
7. Thrown object hazard—Pick up objects that could be thrown by the mower. Do not operate when people and pets are in the area. Keep the deflector in place.
8. Crushing/dismemberment hazard of bystanders—Do not carry passengers, look forward and down when operating the machine, and look behind and down when reversing.



Battery Symbols

Some or all of these symbols are on your battery

- | | |
|--|--|
| 1. Explosion hazard | 6. Keep bystanders a safe distance away from the battery. |
| 2. No fire, open flame, or smoking | 7. Wear eye protection; explosive gases can cause blindness and other injuries |
| 3. Caustic liquid/chemical burn hazard | 8. Battery acid can cause blindness or severe burns. |
| 4. Wear eye protection. | 9. Flush eyes immediately with water and get medical help fast. |
| 5. Read the <i>Operator's Manual</i> . | 10. Contains lead; do not discard. |

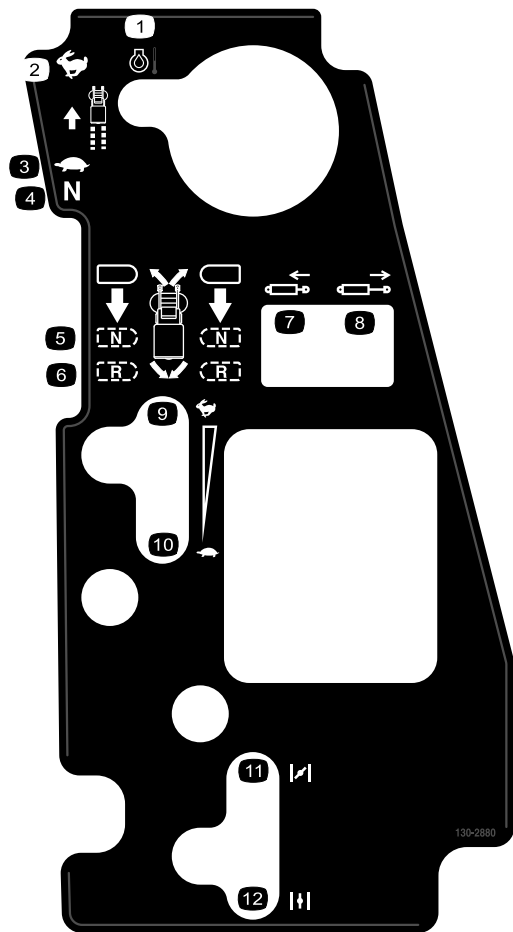

130-2880

decal130-2880

- | | |
|-----------------------|-----------------------|
| 1. Engine temperature | 7. Retract the piston |
| 2. Fast | 8. Extend the piston |
| 3. Slow | 9. Fast |
| 4. Neutral | 10. Slow |
| 5. Neutral | 11. Choke—closed/on |
| 6. Reverse | 12. Choke—open/off |

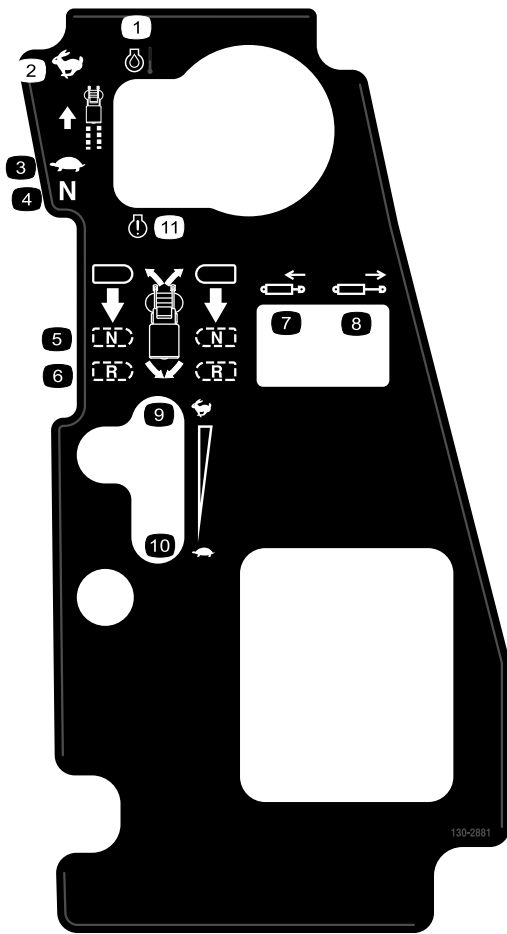

130-2881

decal130-2881

- | | |
|-----------------------|-----------------------|
| 1. Engine temperature | 7. Retract the piston |
| 2. Fast | 8. Extend the piston |
| 3. Slow | 9. Fast |
| 4. Neutral | 10. Slow |
| 5. Neutral | 11. MIL toggle switch |
| 6. Reverse | |

Product Overview

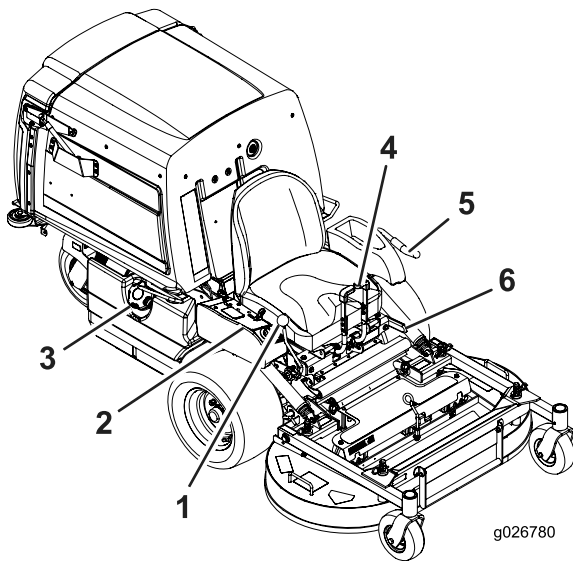

Figure 4

- | | |
|------------------------|--------------------------|
| 1. Speed-control lever | 4. Motion-control levers |
| 2. Controls | 5. PTO-engagement lever |
| 3. Fuel cap | 6. Parking-brake lever |

Controls

Become familiar with all the controls before you start the engine and operate the machine (Figure 4 and Figure 5).

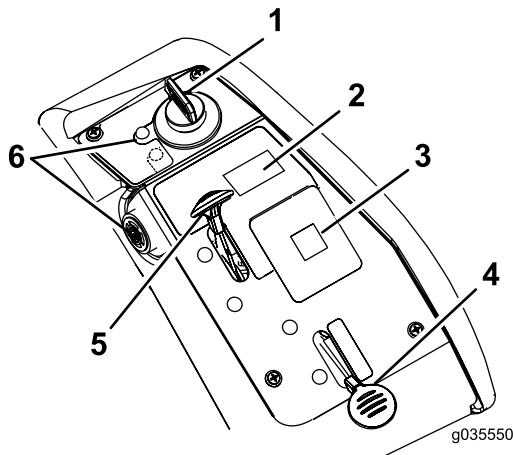

Figure 5

- | | |
|--------------------|--|
| 1. Ignition switch | 4. Choke |
| 2. Hopper switch | 5. Throttle |
| 3. Message display | 6. Engine-oil temperature light and buzzer |

Ignition Switch

Use this switch to start the mower engine. It has 3 positions: START, RUN, and OFF.

Choke Control

Use the choke to start a cold engine. Pull the choke knob up to engage it. Push the choke knob down to disengage it (Figure 5).

Throttle Control

The throttle controls the engine speed, and it has a continuous-variable setting from the SLOW to FAST position (Figure 5).

PTO-Engagement Lever

Use the PTO-engagement lever to engage the blades and the blower. Pull the lever up to engage the blades and blower. To disengage the blades and blower, push the PTO-engagement lever down.

Motion-Control Levers

Use the motion-control levers to drive the machine forward, reverse, and turn either direction.

Speed-Control Lever

The speed-control lever sets maximum forward speed of the machine (Figure 4). Moving the speed-control lever rearward to the NEUTRAL position places the drive system into neutral.

Brake Lever

The brake lever engages a parking brake on the drive wheels (Figure 4).

Hour Meter

The hour meter records the number of hours the engine has operated. The hour meter is recording when the decimal point is flashing in the Hour/Voltage display. Use these times for scheduling regular maintenance (Figure 6).

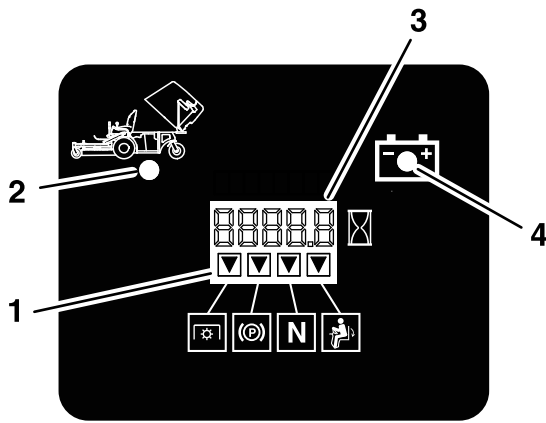

G020563

g020563

Figure 6

1. Safety-interlock indicators
2. Hopper up
3. Hour/Voltage display
4. Low-voltage indicator light

Battery-Indicator Light

If you turn the ignition key to the ON position for a few seconds, the battery voltage displays in the area where the hours are normally displayed.

The battery light turns on when the ignition is turned on and when the charge is below the correct operating level (Figure 6).

Safety-Interlock Indicators

There are symbols on the hour meter, and they indicate with a black triangle that the interlock component is in the correct position (Figure 6).

Fuel-Shutoff Valve

Close the fuel-shutoff valve (under the hopper) when transporting or storing the mower.

Engine-Oil-Temperature Light and Buzzer

The engine-oil-temperature light monitors the temperature of the engine oil. An illuminated engine-oil-temperature light and intermittent buzzing sound signals the engine is overheating.

Attachments/Accessories

A selection of Toro approved attachments and accessories is available for use with the machine to enhance and expand its capabilities. Contact your Authorized Service Dealer or Distributor or go to www.Toro.com for a list of all approved attachments and accessories.

Specifications

Note: Specifications and design are subject to change without notice.

Width

| | 42-inch Mower Deck |
|--------------------|---------------------------|
| Without Mower Deck | 108.2 cm (42.6 inches) |
| With Mower Deck | 109.7 cm (43.2 inches) |

Length

| | 42-inch Mower Deck |
|--------------------|---------------------------|
| Without Mower Deck | 170.9 cm (67.3 inches) |
| Mower Deck—Up | 209.3 cm (82.4 inches) |
| Mower Deck—Down | 233.2 cm (91.8 inches) |

Height

| 42-inch Mower Deck |
|---------------------------|
| 130.0 cm (51.2 inches) |

Weight

| 42-inch Mower Deck |
|---------------------------|
| 517 kg (1,140 lb) |

Operation

Note: Determine the left and right sides of the machine from the normal operating position.

Before Operation

Before Operation Safety

General Safety

- Never allow children or untrained people to operate or service the machine. Local regulations may restrict the age of the operator. The owner is responsible for training all operators and mechanics.
- Become familiar with the safe operation of the equipment, operator controls, and safety signs.
- Know how to stop the machine and shut off the engine quickly.
- Check that operator-presence controls, safety switches, and shields are attached and functioning properly. Do not operate the machine unless they are functioning properly.
- Before mowing, always inspect the machine to ensure that the blades, blade bolts, and cutting assemblies are in good working condition. Replace worn or damaged blades and bolts in sets to preserve balance.
- Inspect the area where you will use the machine and remove all objects that the machine could throw.
- Evaluate the terrain to determine the appropriate equipment and any attachments or accessories required to operate the machine properly and safely.

Fuel Safety

- To avoid personal injury or property damage, use extreme care in handling fuel. Fuel vapors are flammable and explosive.
- Extinguish all cigarettes, cigars, pipes, and other sources of ignition.
- Use only an approved fuel container.
- Do not remove the fuel cap or add fuel to the fuel tank while the engine is running or while hot.
- Do not refuel the machine indoors.
- Do not store the machine or fuel container where there is an open flame, spark, or pilot light, such as on a water heater or on other appliances.
- Do not fill containers inside a vehicle or on a truck or trailer bed with a plastic liner. Always place

containers on the ground, away from your vehicle before filling.

- Remove the equipment from the truck or trailer and refuel it while it is on the ground. If this is not possible, then refuel from a portable container rather than a fuel-dispenser nozzle.
- Do not operate the machine without the entire exhaust system in place and in proper working condition.
- Keep the fuel-dispenser nozzle in contact with the rim of the fuel tank or container opening at all times until fueling is complete. Do not use a nozzle lock-open device.
- If you spill fuel on your clothing, change your clothing immediately. Wipe up any fuel that spills.
- Never overfill the fuel tank. Replace the fuel cap and tighten it securely.
- Store fuel in an approved container and keep it out of the reach of children. Never buy more than a 30-day supply of fuel.
- Do not fill the fuel tank completely full. Add fuel to the fuel tank until the level is 6 to 13 mm (1/4 to 1/2 inch) below the bottom of the filler neck. This empty space in the tank allows fuel to expand.
 - Avoid prolonged breathing of vapors.
 - Keep your face away from the nozzle and fuel tank opening.
 - Avoid contact with skin; wash off spills with soap and water.

Recommended Fuel

- For best results, use only clean, fresh (less than 30 days old), unleaded gasoline with an octane rating of 87 or higher ((R+M)/2 rating method).
- **Ethanol:** Gasoline with up to 10% ethanol (gasohol) or 15% MTBE (methyl tertiary butyl ether) by volume is acceptable. Ethanol and MTBE are not the same. Gasoline with 15% ethanol (E15) by volume is not approved for use. **Never use gasoline that contains more than 10% ethanol by volume**, such as E15 (contains 15% ethanol), E20 (contains 20% ethanol), or E85 (contains up to 85% ethanol). Using unapproved gasoline may cause performance problems and/or engine damage which may not be covered under warranty.
- **Do not** use gasoline containing methanol.
- **Do not** store fuel either in the fuel tank or fuel containers over the winter unless you use a fuel stabilizer.
- **Do not** add oil to gasoline.

Using Stabilizer/Conditioner

Use a fuel stabilizer/conditioner in the machine to provide the following benefits:

- Keeps fuel fresh during storage of 90 days or less (drain the fuel tank when storing the machine for more than 90 days)
- Cleans the engine while it runs
- Eliminates gum-like varnish buildup in the fuel system, which causes hard starting

Important: Do not use fuel additives containing methanol or ethanol.

Add the correct amount of fuel stabilizer/conditioner to the fuel.

Note: A fuel stabilizer/conditioner is most effective when mixed with fresh fuel. To minimize the chance of varnish deposits in the fuel system, use fuel stabilizer at all times.

Filling the Fuel Tank

Note: Do not fill the fuel tank completely full. Fill the fuel tank to the bottom of the filler neck. The empty space in the tank allows the fuel to expand.

1. Park the machine on level ground.
2. Shut the engine off and engage the parking brake.
3. Clean around the fuel-tank cap and remove it.
4. Fill the fuel tank to the bottom of the filler neck.

Note: Ensure that there is empty space in the tank to allow the gasoline to expand; refer to (Figure 4).

Checking the Engine-Oil Level

Before you start the engine and use the machine, check the oil level in the engine crankcase; refer to [Checking the Engine-Oil Level \(page 34\)](#).

Breaking in a New Machine

New engines take time to develop full power. Mower decks and drive systems have higher friction when new, placing additional load on the engine. Allow 40 to 50 hours of break-in time for new machines to develop full power and best performance.

Think Safety First

Please read all safety instructions and symbols in the safety section. Knowing this information could help you or bystanders avoid injury.

⚠ DANGER

Operating the machine on wet grass or steep slopes can cause sliding and loss of control.

- Do not operate on slopes greater than 15 degrees.
- Reduce speed and use extreme caution on slopes.
- Do not operate the machine near water.

⚠ DANGER

Wheels dropping over edges can cause rollovers, which may result in serious injury, death, or drowning.

Do not operate the machine near drop-offs.

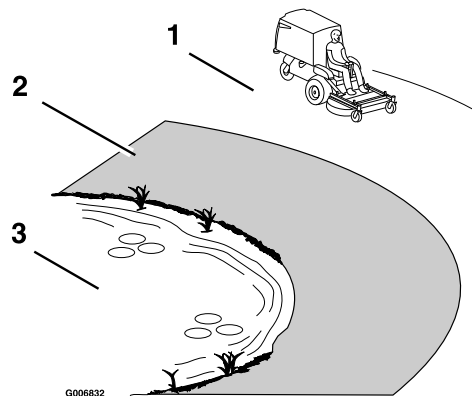

Figure 7

1. Safe Zone—use the machine here on slopes less than 15 degrees or flat areas.
2. Danger Zone—use a walk-behind mower and/or a hand trimmer on slopes greater than 15 degrees, near drop-offs and water.
3. Water

⚠ CAUTION

This machine produces sound levels in excess of 85 dBA at the operator's ear and can cause hearing loss through extended periods of exposure.

Wear hearing protection when operating this machine.

Use protective equipment for your eyes, ears, hands, feet, and head.

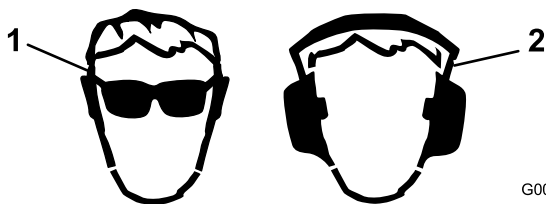

Figure 8

1. Wear eye protection.
2. Wear hearing protection.

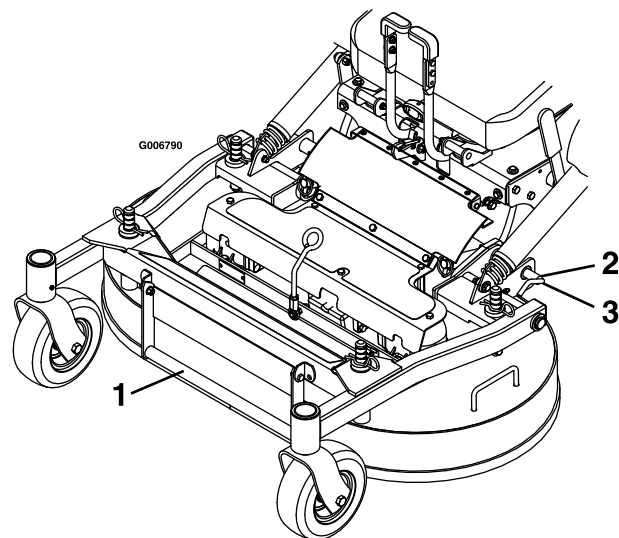

Figure 9

1. Deck-lift handle
2. Rotate the pin toward the rear and pull outward to unlock.
3. Push the pin in and rotate it toward the front to lock.

Raising the Mower Deck into the Service Position

1. Shut off the engine, wait for all moving parts to stop, and remove the key. Engage the parking brake.

⚠ WARNING

Incorrectly raising or lowering a mower deck can be dangerous. A dropped mower deck can result in a serious injury or property damage.

- Always raise and lower the mower deck on flat, dry ground, free of any obstructions.
 - Firmly grasp the mower-deck-lift handle and lower it in a slow, controlled manner.
 - Always make sure the mower deck is securely latched in the up or down position.
2. Release the mower-deck locking pins on each side (Figure 9).

3. Using the deck-lift handle, lift the deck up and latch it in the Up position (Figure 10).

Note: The latch is located at the front center of the seat.

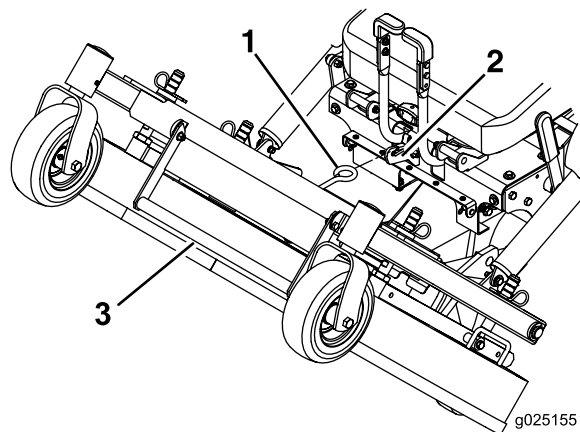

Figure 10

1. Secure the mower-deck latch onto the hook.
2. Hook
3. Deck-lift handle

⚠ WARNING

Operating the mower deck in the raised service position can be dangerous. Engaging the PTO with a deck in the raised position can result in a serious injury or property damage.

Always lower and lock mower deck in the operation position before engaging the PTO.

Lowering the Mower Deck to the Operating Position

1. While firmly holding onto the deck-lift handle, unhook the mower-deck latch from the machine and slowly lower the mower deck to the ground (Figure 10).
2. Push the deck-locking pins inward and rotate them forward to securely lock the mower deck in the lowered position (Figure 9).

⚠ WARNING

Operating the mower without the locking pins securely latched can result in the mower deck folding up unexpectedly. The mower deck folding up unexpectedly can cause serious injury.

Always operate mower with locking pins securely latched.

Adjusting the Fill Reduction System (FRS) Baffles

The fill reduction system has been designed to allow you to reduce the amount of clippings collected by varying degrees.

The advantages include less frequent emptying of the hopper and the return of nutrients to the soil.

The following are possible configurations:

- Baffles open with standard blades—maximum collection
- Baffles closed with standard blades—partial mulching
- Baffles closed with mulch blades—intermediate mulching
- Mulch plug installed with mulch blades—complete mulching (requires mulch kit)

Adjust the FRS baffles as follows:

1. Shut off the engine, wait for all moving parts to stop, and remove key.
2. Engage the parking brake.
3. Remove the hairpin cotters and clevis pins from both sides of the PTO guard (Figure 11).
4. Fold the guard forward.

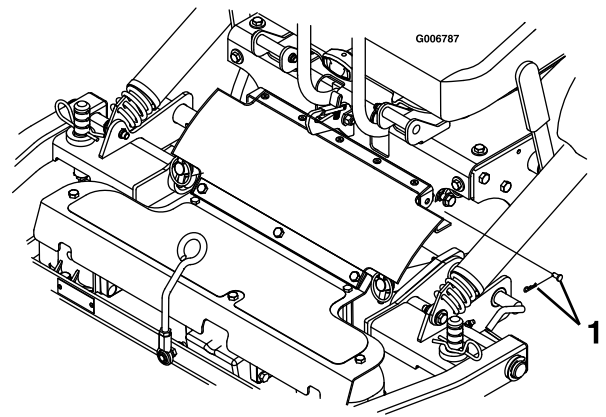

Figure 11

1. Hairpin cotter and clevis pin

g006787

5. Loosen the locknuts on the rear studs of the FRS baffles.

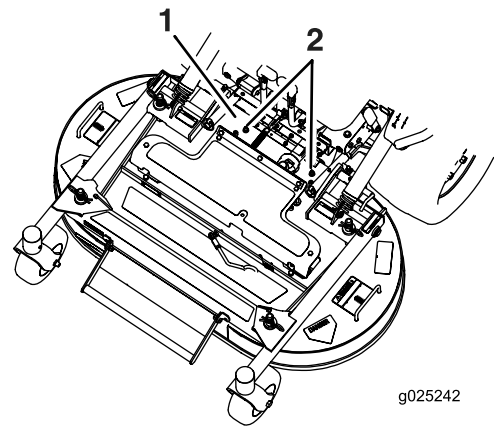

Figure 12

1. PTO guard removed for clarity
2. Loosen the locknuts.

g025242

6. Raise the mower deck; refer to [Raising the Mower Deck into the Service Position](#) (page 17).
7. Remove the bolt and washer at the front of each FRS baffle (Figure 13).
8. Rotate the baffles into the desired position and install the bolt and washer.

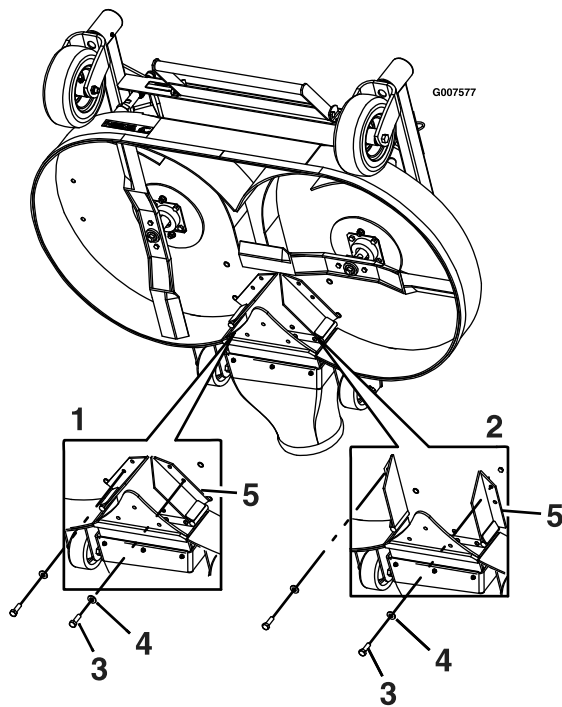

Figure 13

1. Baffles—closed position
2. Baffles—open position
3. Bolt
4. Washer
5. Baffles

9. Lower the mower deck; refer to [Lowering the Mower Deck to the Operating Position \(page 18\)](#).
10. Slightly tighten the locknuts on the rear studs of the FRS baffles.

Note: The locknuts on the rear studs may be left slightly loose if you anticipate adjusting the baffle frequently.

11. Install the PTO guard using the clevis pins and hairpin cotters removed in step 3.

The Safety-Interlock System

⚠ CAUTION

If the safety-interlock switches are disconnected or damaged, the machine could operate unexpectedly, causing personal injury.

- Do not tamper with the interlock switches.
- Check the operation of the interlock switches daily and replace any damaged switches before operating the machine.

Understanding the Safety-Interlock System

The safety-interlock system is designed to prevent the engine from starting unless:

- The parking brake is engaged.
- The PTO-engagement lever is disengaged.
- The speed-control lever is in the NEUTRAL position

The safety-interlock system is designed to stop the engine when you rise from the seat when the PTO is engaged.

The hour meter has symbols to notify you when the interlock component is in the correct position. When the component is in the correct position, a triangle lights up in the corresponding square.

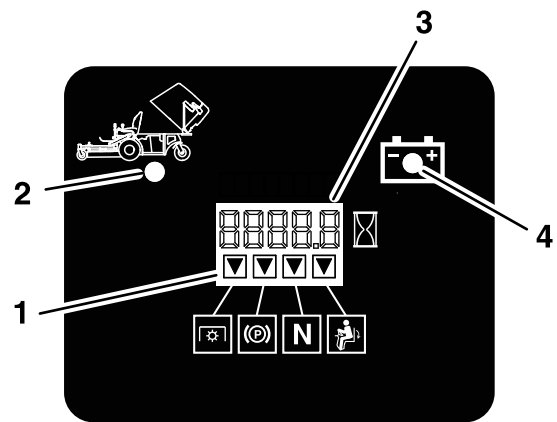

Figure 14

1. Triangles light up when the interlock components are in the correct position.
2. Hopper up
3. Hour/Voltage display
4. Low-voltage indicator light

Testing the Safety-Interlock System

Service Interval: Before each use or daily

Test the safety-interlock system before you use the machine each time. If the safety system does not operate as described below, have an Authorized Service Dealer repair the safety system immediately.

1. Sit on the seat, engage the parking brake, move the PTO-engagement lever to the ON position, and move the speed-control lever to the NEUTRAL position. Try starting the engine; the engine should not start.
2. Sit on the seat, engage the parking brake, and move the PTO-engagement lever to the OFF position. Move the speed-control lever out of the

- NEUTRAL position. Try starting the engine; the engine should not start.
3. Sit on the seat, disengage the parking brake, move the PTO-engagement lever to the OFF position, and move the speed-control lever to the NEUTRAL position. Try starting the engine; the engine should not start.
 4. Sit on the seat, engage the parking brake, move the PTO-engagement lever to the OFF position, and move the speed-control lever to the NEUTRAL position. Now start the engine. While the engine is running, release the parking brake, engage the PTO-engagement lever, and rise slightly from the seat; the engine should shut off.
 5. Sit on the seat, engage the parking brake, move the PTO-engagement lever to the OFF position, and move the speed-control lever to the NEUTRAL position. Now start the engine. Move the speed-control lever forward; the engine should shut off.

During Operation

During Operation Safety

General Safety

- The owner/operator can prevent and is responsible for accidents that may cause personal injury or property damage.
 - Wear appropriate clothing, including eye protection; slip-resistant, substantial footwear; and hearing protection. Tie back long hair and do not wear jewelry.
 - Do not operate the machine while ill, tired, or under the influence of alcohol or drugs.
 - Never carry passengers on the machine and keep bystanders and pets away from the machine during operation.
 - Operate the machine only in good visibility to avoid holes or hidden hazards.
 - Avoid mowing on wet grass. Reduced traction could cause the machine to slide.
 - Ensure that all drives are in neutral, the parking brake is engaged, and you are in the operating position before you start the engine.
 - Keep your hands and feet away from the cutting units. Keep clear of the discharge opening at all times.
 - Look behind and down before backing up to be sure of a clear path.
 - Use care when approaching blind corners, shrubs, trees, or other objects that may obscure your vision.
- Do not mow near drop-offs, ditches, or embankments. The machine could suddenly roll over if a wheel goes over the edge or if the edge gives way.
 - Stop the blades whenever you are not mowing.
 - Stop the machine and inspect the blades after striking an object or if there is an abnormal vibration in the machine. Make all necessary repairs before resuming operation.
 - Slow down and use caution when making turns and crossing roads and sidewalks with the machine. Always yield the right-of-way.
 - Disengage the drive to the cutting unit and shut off the engine before adjusting the height of cut (unless you can adjust it from the operating position).
 - Never run an engine in an area where exhaust gases are enclosed.
 - Never leave a running machine unattended.
 - Before leaving the operating position (including to empty the catchers or to unclog the chute), do the following:
 - Stop the machine on level ground.
 - Disengage the power take-off and lower the attachments.
 - Engage the parking brake.
 - Shut off the engine and remove the key.
 - Wait for all moving parts to stop.
 - Do not operate the machine when there is the risk of lightning.
 - Do not use the machine as a towing vehicle.
 - Do not change the governor speed or overspeed the engine.
 - Use accessories and attachments approved by Toro only.

Slope Safety

- Slow down the machine and use extra care on hillsides. Travel up and down on hillsides. Turf conditions can affect the stability of the machine.
- Avoid turning the machine on slopes. If you must turn the machine, turn it slowly and gradually downhill, if possible.
- Do not turn the machine sharply. Use care when reversing the machine.
- Use extra care while operating the machine with attachments; they can affect the stability of the machine.
- A 2-post ROPS (Rollover Protection System) is available for the machine as an accessory. A ROPS is recommended if you will be mowing next

to drop-offs, near water, or on steep banks which could result in a rollover. Contact an Authorized Service Dealer for more details. The California Code of Regulations requires ROPS (if available) on all mowers used commercially effective March 1, 2011.

2. Turn the ignition key to the STOP position to shut off the engine.

Operating the Throttle

You can move the throttle control between the FAST and SLOW positions (Figure 15).

Always use the middle position when turning on the mower deck and blower with the PTO-engagement lever.

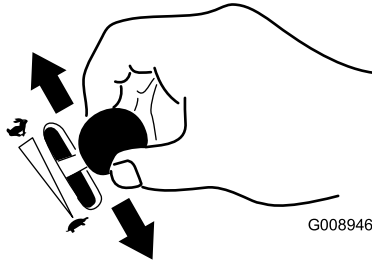

Figure 15

g008946

Operating the Ignition Switch

1. Turn the ignition key to the START position (Figure 16).

Note: When the engine starts, release the key.

Important: Do not engage the starter for more than 5 seconds at a time. If the engine fails to start, wait 15 seconds between attempts. Failure to follow these instructions can burn out the starter motor.

Note: You may need multiple attempts to start the engine when you start it the first time after the fuel system has been without fuel completely.

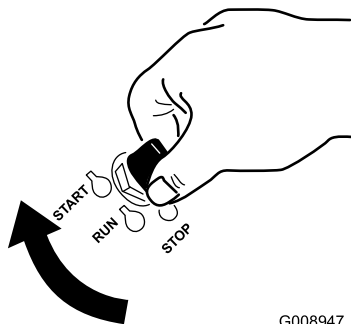

Figure 16

G008947

g008947

Operating the PTO-Engagement Lever

The PTO-engagement lever starts and stops the mower blades and blower.

⚠ WARNING

An uncovered discharge opening allows objects to be thrown at you and bystanders. Also, contact with the blower blades could occur. Thrown objects or blade contact can cause serious injury or death.

Never operate the mower with the hopper or hopper door raised, removed, or altered.

Engaging the PTO-Engagement Lever

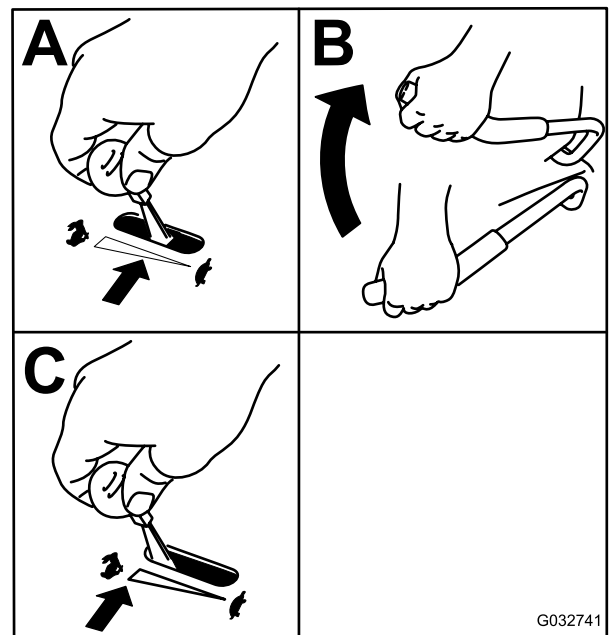

Figure 17

g032741

Disengaging the PTO-Engagement Lever

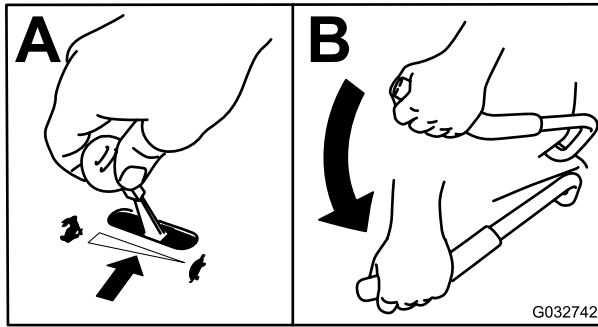

Figure 18

Disengaging the Parking Brake

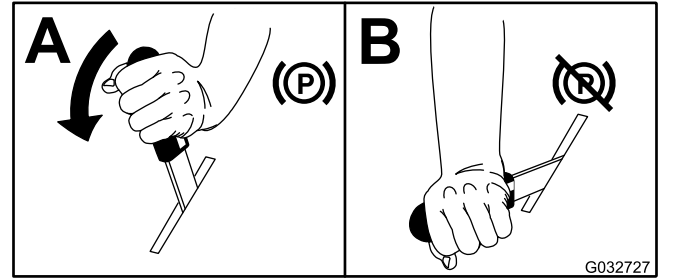

Figure 20

Operating the Parking Brake

Always engage the parking brake when you stop the machine or leave it unattended.

Engaging the Parking Brake

⚠ WARNING

The parking brake may not hold the machine parked on a slope and could cause personal injury or property damage.

Do not park on slopes unless the wheels are chocked or blocked.

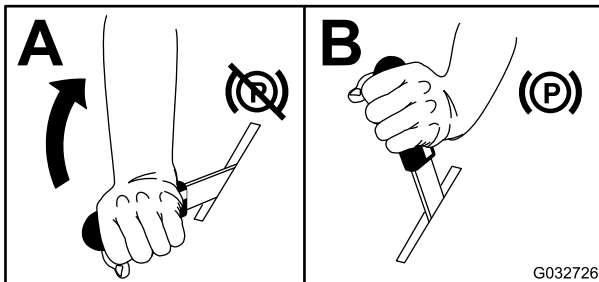

Figure 19

Starting and Shutting Off the Engine

Starting the Engine

1. Move the speed-control lever to the NEUTRAL position.
2. Engage the parking brake; refer to [Engaging the Parking Brake \(page 22\)](#).
3. Move the PTO-engagement lever to the OFF position ([Figure 21](#)).
4. Move the throttle lever midway between the SLOW and FAST positions.

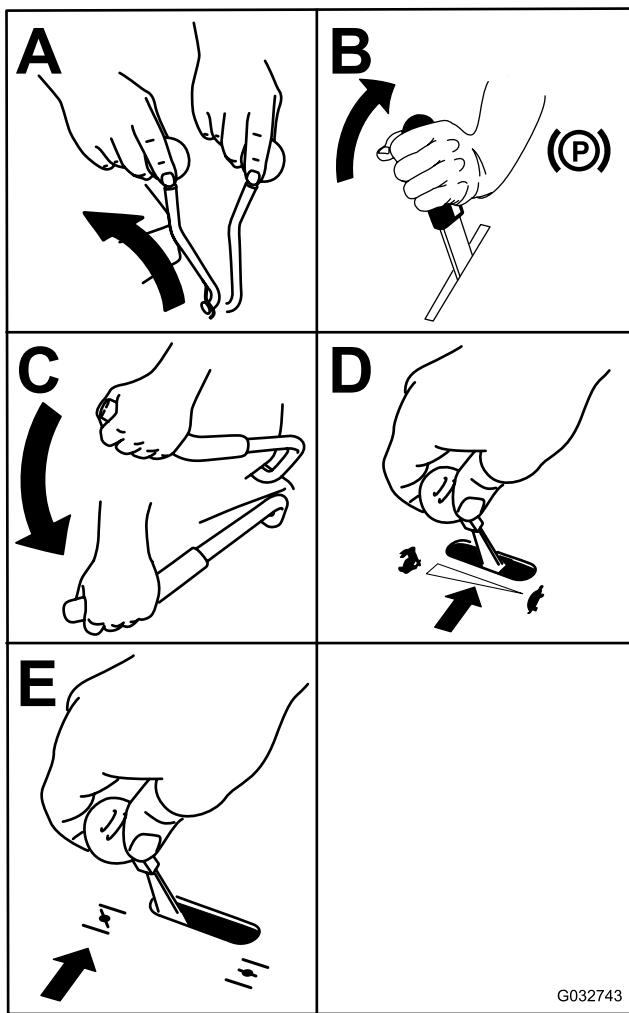

Figure 21

Shutting Off the Engine

⚠ CAUTION

Children or bystanders may be injured if they move or attempt to operate the machine while it is unattended.

Always remove the ignition key and engage the parking brake when leaving the machine unattended, even if just for a few minutes.

Important: Make sure that the fuel-shutoff valve is closed before transporting or storing the machine, as fuel leakage may occur. Engage the parking brake before transporting. Remove the key as the fuel pump may run and cause the battery to lose charge.

1. Disengage the PTO.
2. Move the speed-control lever to the NEUTRAL position.
3. Engage the parking brake.
4. Place the throttle in the middle position.
5. Allow the engine to run for a minimum of 15 seconds, then turn the ignition switch to the OFF position to shut off the engine.
6. Remove the key to prevent children or other unauthorized persons from starting the engine.

5. Turn the ignition key to the START position (Figure 16). When the engine starts, release the key.

Important: Do not crank the engine continuously for more than 10 seconds at a time. If the engine does not start, wait 60 seconds between starting attempts. Failure to follow these guidelines can burn out the starter motor.

Note: Additional starting cycles may be required when starting the engine for the first time after the fuel system has been without fuel completely.

6. If the choke is in the CLOSED/ON position, gradually return choke to the OPEN/OFF position as the engine warms up.

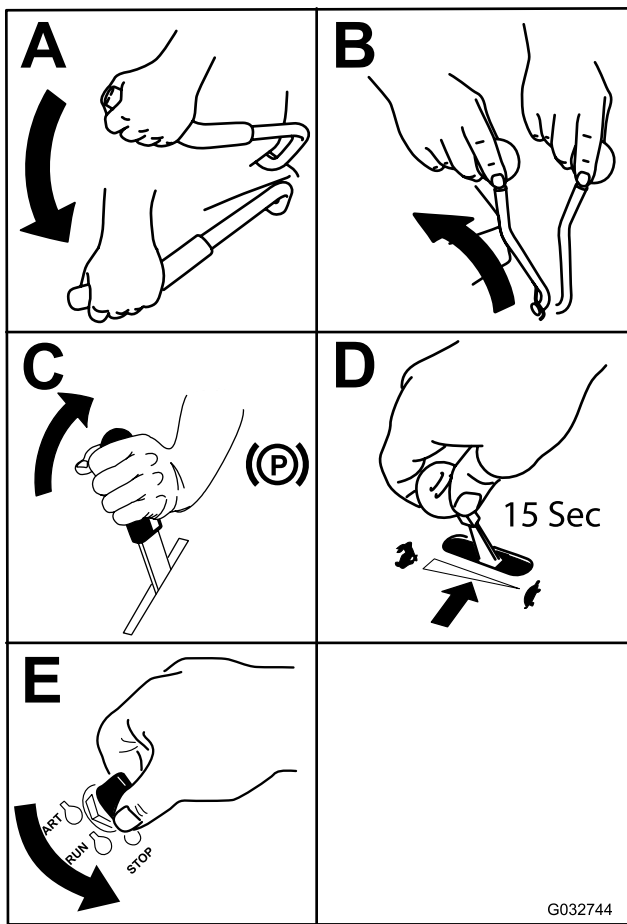

Figure 22

7. Close the fuel-shutoff valve when the machine will not be in use for a few days, when transporting, or when the unit is parked inside a building.

Driving Forward or Backward

The throttle control regulates the engine speed as measured in rpm (revolutions per minute). Place the throttle control in the FAST position for best performance. Always operate in the full throttle position when mowing.

⚠ CAUTION

Machine can spin very rapidly. You may lose control of machine and cause personal injury or damage to machine.

- Use caution when making turns.
- Slow the machine down before making sharp turns.

Driving Forward

Note: To begin movement (forward or backward), sit in the seat, disengage (push down) the brake lever, then move the speed-control lever forward; otherwise, the engine will stop.

To stop the machine, pull the speed control lever to the NEUTRAL position.

1. Start the engine.
2. Disengage the parking brake; refer to [Disengaging the Parking Brake \(page 22\)](#).
3. To move forward in a straight line move the speed control lever forward.

Note: The machine moves faster the farther the speed-control lever is moved away from neutral.

4. To turn left or right, pull 1 of the steering levers back toward neutral in the direction desired.
5. To stop the machine, pull the speed-control lever back to the NEUTRAL position.

Driving Backward

1. To move rearward in a straight line, pull both steering levers rearward equally.

To turn left or right, release pressure on the steering lever toward the direction desired.

2. To stop the machine, release the steering levers to the neutral position.

Adjusting the Height of Cut

The cutting height of the mower deck is adjusted from 2.5 to 10.2 cm (1 to 4 inches) in 6.3 mm (1/4 inch) increments.

1. Move the speed-control lever to the NEUTRAL position to stop the machine.
2. Disengage the PTO, engage the parking brake, shut off the engine, and wait for all moving parts to stop.
3. Using the mower-deck handle, raise the mower deck, and move the cotter pins to the desired height-of-cut position. Repeat for the opposite side.

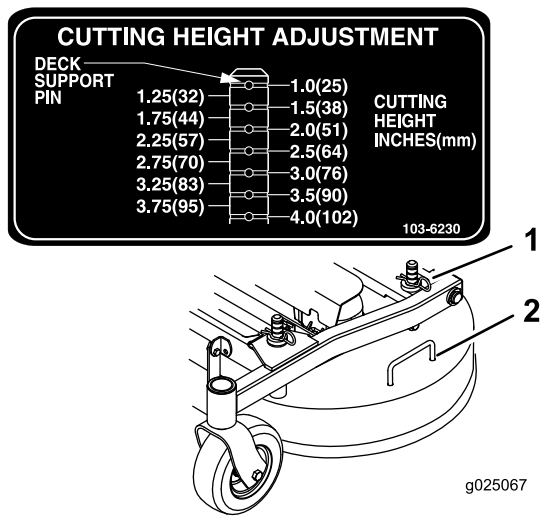

Figure 23

1. Cotter pin
2. Mower-deck handle

Stopping the Machine

1. Pull the speed-control lever back to the NEUTRAL position, disengage the PTO-engagement lever, and turn the ignition key to the OFF position.
2. Engage the parking brake when you leave the machine; refer to [Engaging the Parking Brake \(page 22\)](#).
3. Remove the key from the ignition switch.

CAUTION

Children or bystanders may be injured if they move or attempt to operate the machine while it is unattended.

Always remove the ignition key and engage the parking brake when leaving the machine unattended, even if just for a few minutes.

Emptying the Hopper

A full hopper is indicated by a buzzer located behind the seat, in the hopper. Empty the hopper when the buzzer sounds to prevent clogging of the blower or the mower deck.

1. Disengage the PTO, move the speed-control lever to the NEUTRAL position, engage the parking brake, and dismount the machine.
2. Make sure that machine is on a dry level surface.
3. Lift the rear door up and allow it to rest on top of hopper.
4. Using the handles at the lower front of the hopper, raise the hopper to dump the contents.
5. Lower the hopper and close the hopper door.

Operating Tips

Using the Fast Throttle Setting

For best mowing and maximum air circulation, operate the engine at the FAST position. Air is required to thoroughly cut grass clippings, so do not set the height-of-cut so low as to totally surround the mower in uncut grass. Always try to have 1 side of the mower free from uncut grass, which allows air to be drawn into the mower.

Cutting a Lawn for the First Time

Cut grass slightly longer than normal to ensure that the cutting height of the mower does not scalp any uneven ground. However, the cutting height used in the past is generally the best one to use. When cutting grass longer than 15 cm (6 inches) tall, you may want to cut the lawn twice to ensure an acceptable quality of cut.

Cutting a Third of the Grass Blade

It is best to cut only about a third of the grass blade. Cutting more than that is not recommended unless grass is sparse, or it is late fall when grass grows more slowly.

Alternating the Mowing Direction

Alternate the mowing direction to keep the grass standing straight. This also helps disperse clippings which enhances decomposition and fertilization.

Mowing at Correct Intervals

Grass grows at different rates at different times of the year. To maintain the same cutting height, mow more often in early spring. As the grass growth rate slows in mid summer, mow less frequently. If you cannot mow for an extended period, first mow at a high cutting height, then mow again 2 days later at a lower height setting.

Using a Slower Cutting Speed

To improve cut quality, use a slower ground speed in certain conditions.

Avoiding Cutting Too Low

When mowing uneven turf, raise the cutting height to avoid scalping the turf.

Stopping the Machine

If you must stop the forward motion of the machine while mowing, a clump of grass clippings may drop onto your lawn. To avoid this, move onto a previously cut area with the blades engaged or you can disengage the mower deck while moving forward.

Keeping the Underside of the Mower Clean

Clean clippings and dirt from the underside of the mower after each use. If grass and dirt build up inside the mower, cutting quality will eventually become unsatisfactory.

Maintaining the Blade(s)

Maintain a sharp blade throughout the cutting season because a sharp blade cuts cleanly without tearing or shredding the grass blades. Tearing and shredding turns grass brown at the edges, which slows growth and increases the chance of disease. Check the mower blades after each use for sharpness, and for any wear or damage. File down any nicks and sharpen the blades as necessary. If a blade is damaged or worn, replace it immediately with a genuine Toro replacement blade.

After Operation

After Operation Safety

General Safety

- Clean grass and debris from the cutting units, mufflers, and engine compartment to help prevent fires. Clean up oil or fuel spills.
- Shut off the fuel before storing or transporting the machine.
- Disengage the drive to the attachment whenever you are transporting or not using the machine.
- Use full-width ramps for loading the machine into a trailer or truck.
- Tie the machine down securely using straps, chains, cable, or ropes. Both front and rear straps should be directed down and outward from the machine.
- Allow the engine to cool before storing the machine in any enclosure.
- Never store the machine or fuel container where there is an open flame, spark, or pilot light, such as on a water heater or on other appliances.

Clearing the Hopper Screen

Remove the screen by firmly lifting the screen handles (Figure 24).

Pull the screen towards the back to remove it. As needed, gently tap the screen to remove debris.

Note: Excessive buildup on the screen can cause the blower to plug.

Note: In conditions where the screen clogs quickly, you can turn and install the front removable screen panel under the primary screen to allow free air flow from the hopper.

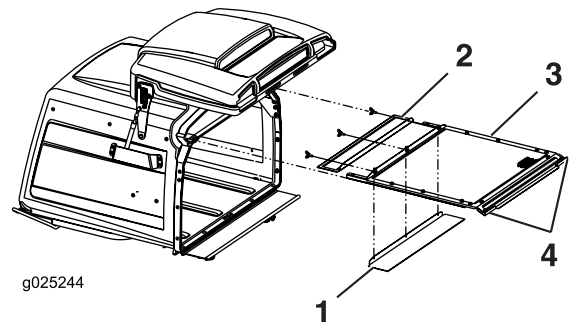

Figure 24

1. Front removable screen can be rotated and stored for wet conditions.
2. Front removable screen
3. Primary screen
4. Handles

Using the Drive-Wheel Release Valves

⚠ WARNING

Hands may become entangled in the rotating drive components below the engine deck, which could result in serious injury.

Shut off the engine, remove the key, and wait for all moving parts to stop before accessing the drive-wheel release valves.

⚠ WARNING

The engine and hydraulic drive units can become very hot. Touching a hot engine or hydraulic drive units can cause severe burns.

Wait for the engine and hydraulic drive units to cool completely before accessing the drive-wheel release valves.

The drive-wheel release valves are located on the top, left, front corner of the hydrostatic pumps.

1. Move the speed-control lever to the NEUTRAL position to stop the machine.
2. Disengage the PTO lever, engage the parking brake, shut off the engine, and wait for all moving parts to stop.
3. Tilt the seat up to gain access to the pumps.
4. Rotate both release valves 1 turn counterclockwise to release the drive system.

Note: This allows the hydraulic fluid to bypass the pump, enabling the wheels to turn.

5. Disengage the parking brake before pushing the machine.
6. Rotate the valves clockwise to run the machine.

Note: Do not tow the machine.

Note: Do not overtighten the valves.

Transporting the Machine

Use a heavy-duty trailer or truck to transport the machine. Ensure that the trailer or truck has all necessary brakes, lighting, and marking as required by law. Please carefully read all the safety instructions. Knowing this information could help you, your family, pets, or bystanders avoid injury.

⚠ WARNING

Driving on the street or roadway without turn signals, lights, reflective markings, or a slow-moving vehicle emblem is dangerous and can lead to accidents causing personal injury.

Do not drive the machine on a public street or roadway.

1. If using a trailer, connect it to the towing vehicle and connect the safety chains.
2. If applicable, connect the trailer brakes.
3. Load the machine onto the trailer or truck.
4. Shut off the engine, remove the key, set the brake, and close the fuel valve.
5. Securely fasten the machine to the trailer or truck with straps, chains, cable, or ropes down and outward from the machine.

Loading the Machine

Use extreme caution when loading or the unloading machine onto a trailer or a truck. Use a full-width ramp that is wider than the machine for this procedure.

Important: If a full-width ramp is not available, use enough individual ramps to simulate a full-width ramp.

Ensure that the ramp is long enough so that the angle with the ground does not exceed 15 degrees. A steeper angle may cause mower components to get caught as the machine moves from the ramp to the trailer or truck. Steeper angles may also cause the machine to tip or lose control. If you are loading the machine on or near a slope, position the trailer or truck so that it is on the down side of the slope and the ramp extends up the slope. This minimizes the ramp angle.

Important: Do not attempt to turn the machine while on the ramp, you may lose control and drive off the side.

⚠ WARNING

Loading a machine onto a trailer or truck increases the possibility of a tip-over and could cause serious injury or death.

- Use extreme caution when operating a machine on a ramp.
- Use only a full-width ramp; do not use individual ramps for each side of the machine.
- If a full-width ramp is not available, use enough individual ramps to simulate a full width ramp.
- Do not exceed a 15-degree angle between the ramp and the ground or between the ramp and the trailer or truck.
- Avoid sudden acceleration or deceleration while driving the machine on a ramp as this could cause a loss of control or a tip-over.

Maintenance

Recommended Maintenance Schedule(s)

| Maintenance Service Interval | Maintenance Procedure |
|------------------------------|---|
| After the first 50 hours | <ul style="list-style-type: none"> • Change the oil in all 3 gearbox housings and add oil as needed. |
| After the first 100 hours | <ul style="list-style-type: none"> • Check the wheel-lug nut torque. • Check the wheel-hub nut torque. • Check the parking brake adjustment. • Change the hydraulic filter and reservoir hydraulic fluid when using any type of fluid. |
| Before each use or daily | <ul style="list-style-type: none"> • Check the safety-interlock system. • Grease the front caster wheel hubs (more often in dirty or dusty conditions). • Check the engine-oil level. • Clean the engine screen and the oil cooler. • Clean the hydraulic pumps. • Check the mower blades. • Clean the mower deck. • Clean debris from the machine. |
| Every 40 hours | <ul style="list-style-type: none"> • Grease the drive shaft (more often in dirty or dusty conditions). • Check the tire pressure. • Inspect the belts for cracks and wear. • Check the hydraulic fluid level. |
| Every 50 hours | <ul style="list-style-type: none"> • Check spark arrester (if equipped). |
| Every 100 hours | <ul style="list-style-type: none"> • Grease the mower-deck flip-up pivot (more often in dirty or dusty conditions). • Grease the mower-deck push-arm tubes (more often in dirty or dusty conditions). • Check the oil in all 3 gearbox housings and add oil as needed. • Change the engine oil (more often in dirty or dusty conditions). • Clean the engine-oil cooler. • Check and clean engine cooling fins and shrouds. |
| Every 150 hours | <ul style="list-style-type: none"> • Inspect the primary filter and air-inlet screen. |
| Every 160 hours | <ul style="list-style-type: none"> • Lubricate the brake-handle pivot. • Lubricating the brake-rod bushings and steering linkage rod ends. |
| Every 200 hours | <ul style="list-style-type: none"> • Change the engine-oil filter. • Replace the fuel filter (more often in dirty or dusty conditions). |
| Every 250 hours | <ul style="list-style-type: none"> • Replace the primary air filter (more often in dusty or sandy conditions). • Check the safety air filter. • Change the hydraulic filter and reservoir hydraulic fluid when using Mobil® 1 fluid (more often in dirty or dusty conditions). |
| Every 500 hours | <ul style="list-style-type: none"> • Replace the safety air filter. • Check and gap the spark plug. • Check the wheel-lug nut torque. • Check the wheel-hub nut torque. • Adjust the caster-pivot bearings. • Check the parking brake adjustment. • Change the hydraulic filter and reservoir hydraulic fluid when using Toro® HYPR-OIL™ 500 hydraulic fluid (more often in dirty or dusty conditions). |
| Every 2,000 hours | <ul style="list-style-type: none"> • Change the oil in all 3 gearbox housings and add oil as needed. |
| Monthly | <ul style="list-style-type: none"> • Check the battery. |

| Maintenance Service Interval | Maintenance Procedure |
|------------------------------|--|
| Yearly | <ul style="list-style-type: none"> • Grease the front caster pivots (more often in dirty or dusty conditions). • Grease the rear caster hub (more often in dirty or dusty conditions). • Grease the pump-belt idler arm (more often in dirty or dusty conditions). • Grease the PTO-belt idler arm (more often in dirty or dusty conditions). • Grease the rear caster pivot (more often in dirty or dusty conditions). • Lubricate the caster-wheel hubs. |
| Yearly or before storage | <ul style="list-style-type: none"> • Paint chipped surfaces. • Check all maintenance procedures listed above before storage. |

Important: Refer to your engine owner’s manual for additional maintenance procedures.

⚠ CAUTION

If you leave the key in the switch, someone could accidentally start the engine and seriously injure you or other bystanders.

Remove the key from the switch before you perform any maintenance.

Pre-Maintenance Procedures

Maintenance and Storage Safety

- Before repairing the machine do the following:
 - Disengage the drives.
 - Engage the parking brake.
 - Shut off the engine and remove the key.
 - Disconnect the spark-plug wire.
- Park the machine on a level surface.
- Clean grass and debris from the cutting unit, drives, mufflers, and engine to help prevent fires.
- Clean up oil or fuel spills.
- Let the engine cool before storing the machine.
- Do not store the machine or fuel near flames or drain the fuel indoors.
- Do not allow untrained personnel to service the machine.
- Use jack stands to support the machine and/or components when required.
- Carefully release pressure from components with stored energy.
- Disconnect the battery or remove the spark-plug wire before making any repairs. Disconnect the negative terminal first and the positive terminal last. Connect the positive terminal first and negative last.
- Use care when checking the blades. Wrap the blade(s) or wear thickly padded gloves, and use caution when servicing them. Only replace blades; do not straighten or weld them.
- Keep your hands and feet away from moving parts. If possible, do not make adjustments with the engine running.
- Keep all parts in good working condition and all hardware tightened, especially the blade-attachment bolts. Replace all worn or damaged decals.
- Never interfere with the intended function of a safety device or reduce the protection provided by a safety device. Check their proper operation regularly.
- To ensure optimum performance and continued safety certification of the machine, use only genuine Toro replacement parts and accessories. Replacement parts and accessories made by other manufacturers could be dangerous, and such use could void the product warranty.
- Check the parking brake operation frequently. Adjust and service as required.

Lubrication

Lubricating the Machine

Service Interval: Before each use or daily—Grease the front caster wheel hubs (more often in dirty or dusty conditions).

Every 40 hours—Grease the drive shaft (more often in dirty or dusty conditions).

Every 100 hours—Grease the mower-deck flip-up pivot (more often in dirty or dusty conditions).

Every 100 hours—Grease the mower-deck push-arm tubes (more often in dirty or dusty conditions).

Yearly—Grease the front caster pivots (more often in dirty or dusty conditions).

Yearly—Grease the rear caster hub (more often in dirty or dusty conditions).

Yearly—Grease the pump-belt idler arm (more often in dirty or dusty conditions).

Yearly—Grease the PTO-belt idler arm (more often in dirty or dusty conditions).

Yearly—Grease the rear caster pivot (more often in dirty or dusty conditions).

Grease Type: No. 2 lithium or molybdenum grease

1. Disengage the PTO, stop the machine, shut off the engine, remove the key, and wait for all moving parts to stop before leaving the operating position.
2. Clean the grease fittings with a rag. Scrape any paint off the front of the fitting(s).
3. Connect a grease gun to the fitting. Pump grease into the fittings until grease begins to ooze out of the bearings.
4. Wipe up any excess grease.

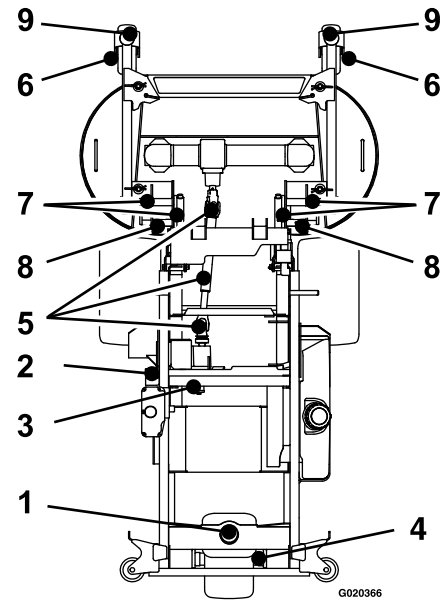

Figure 25

- | | |
|------------------------|---------------------------|
| 1. Rear caster pivot | 6. Front caster wheel hub |
| 2. PTO-belt idler arm | 7. Deck flip-up pivot |
| 3. Pump-belt idler arm | 8. Push-arm tubes |
| 4. Rear caster hub | 9. Front caster pivots |
| 5. Drive shaft | |

Lubricating the Caster-Wheel Hubs

Service Interval: Yearly

1. Shut off the engine, wait for all moving parts to stop, remove the key, and engage the parking brake.

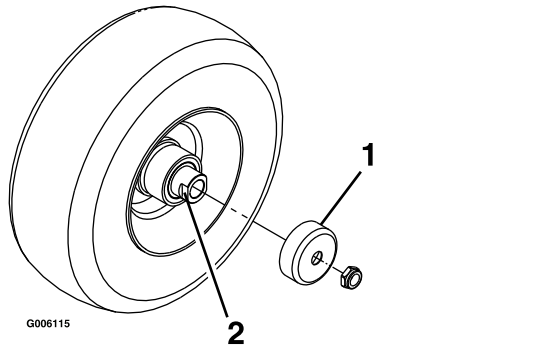

Figure 26

- | | |
|---------------|---------------------------------|
| 1. Seal guard | 2. Spacer nut with wrench flats |
|---------------|---------------------------------|

2. Remove the caster wheel from the caster forks.
3. Remove the seal guards from the wheel hub.
4. Remove a spacer nut from the axle assembly in the caster wheel.

Note: Thread-locking compound has been applied to lock the spacer nuts to the axle.

5. Remove the axle (with the other spacer nut still assembled to it) from the wheel assembly.
6. Pry out the seals and inspect the bearings for wear or damage and replace them if necessary.
7. Pack the bearings with a general-purpose grease.
8. Insert 1 bearing and 1 new seal into the wheel.

Note: Replace the seals.

9. If both spacer nuts have been removed (or broken loose) from the axle assembly, apply a thread-locking compound to 1 spacer nut and thread it onto the axle with the wrench flats facing outward.

Note: Do not thread the spacer nut all of the way onto the end of the axle. Leave approximately 3 mm (1/8 inch) from the outer surface of the spacer nut to the end of the axle inside the nut.

10. Insert the assembled nut and axle into the wheel on the side with the new seal and bearing.
11. With the open end of the wheel facing up, fill the area inside the wheel around the axle full of general-purpose grease.

12. Insert the second bearing and new seal into the wheel.
13. Apply a thread-locking compound to the second spacer nut and thread it onto the axle with the wrench flats facing outward.
14. Torque the nut to 8 to 9 N·m (75 to 80 in-lb), loosen the nut, then torque it to 2 to 3 N·m (20 to 25 in-lb).

Note: Make sure that the axle does not extend beyond either nut.

15. Install the seal guards over the wheel hub and insert wheel into the caster fork.
16. Install the caster bolt and tighten the nut fully.

Important: To prevent seal and bearing damage, check the bearing adjustment often. Spin the caster tire. The tire should not spin freely (more than 1 or 2 revolutions) or have any side play. If the wheel spins freely, adjust the torque on the spacer nut until there is a slight amount of drag. Apply another layer of thread-locking compound.

Lubricating the Brake-Handle Pivot

Service Interval: Every 160 hours

1. Shut off the engine, wait for all moving parts to stop, remove the key, and engage the parking brake.
2. Lubricate the bronze bushings on the brake-handle pivot with a spray type lubricant or light oil (Figure 27).

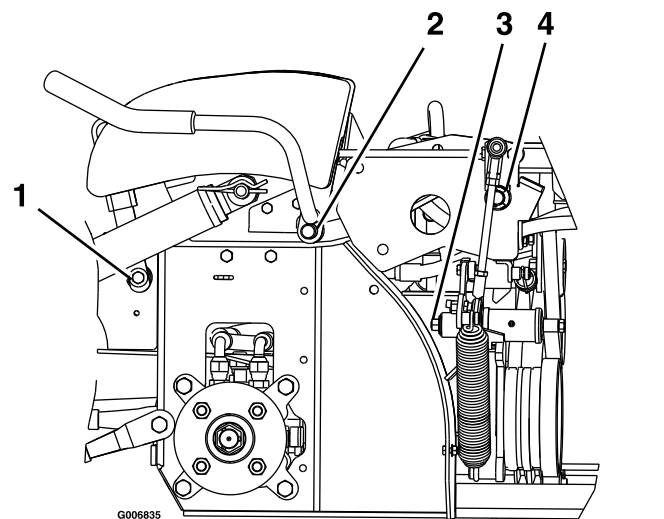

Figure 27

Left Side of Machine Shown

- | | |
|-----------------------|---------------------|
| 1. Brake-handle pivot | 3. Spring-arm pivot |
| 2. PTO-handle pivot | 4. Toggle pivot |

Lubricating the Brake-Rod Bushings and Steering-Linkage Rod Ends

Service Interval: Every 160 hours

1. Shut off the engine, wait for all moving parts to stop, remove the key, and engage the parking brake.
2. Unhook the seat latch and tilt the seat up.
3. Lubricate the bronze bushings on each end of the brake rod shaft with a spray type lubricant or a light oil.
Note: The bushings are located to the inside of the flange bearings.
4. Lubricate each end of both steering linkage rods with a spray lubricant or a light oil.

Changing the Gearbox Oil

Service Interval: After the first 50 hours—Change the oil in all 3 gearbox housings and add oil as needed.

Every 100 hours—Check the oil in all 3 gearbox housings and add oil as needed.

Every 2,000 hours—Change the oil in all 3 gearbox housings and add oil as needed.

1. Place the machine on a level surface.
2. Shut off the engine, wait for all moving parts to stop, remove the key, and engage the parking brake.
3. Remove the gearbox and drive-shaft assembly from the mower deck. Retain the hardware for use later.
4. Remove the large oil drain plug on the front of each of the 3 gearbox sections and drain the oil (Figure 28).

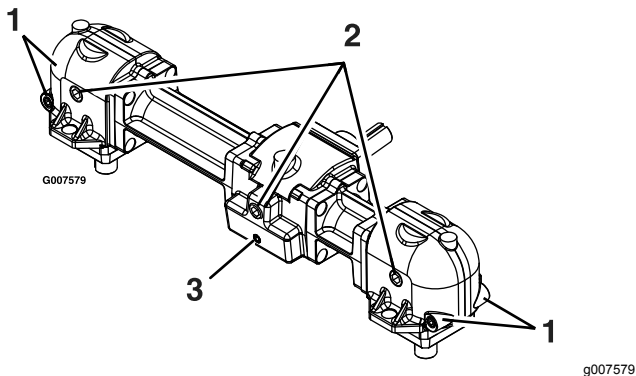

Figure 28

- | | |
|--|-------------------------------------|
| 1. Small magnetic plugs (front and back) | 3. Small magnetic plug (front only) |
| 2. Large oil drain/fill plug | |

5. Remove the small magnetic plugs and wipe away any material accumulated on the plugs.
6. Apply a Teflon® pipe sealant to all small magnetic plugs and install them into the gearbox.
7. Install the gearbox and drive-shaft assembly to the mower deck.
8. Fill the gearbox with Mobil® SHC (synthetic) 75W-90 gear lube oil until level with oil drain/fill plug.
Note: Each of the gearbox sections must be filled separately.
9. Apply a Teflon pipe sealant to the 3 large oil plugs and install them into the gearbox.
Note: Keep the mower deck level to the ground when filling the gearbox with oil. Do not fill the gearbox with the mower deck raised in the service position.

Engine Maintenance

⚠ WARNING

Contact with hot surfaces may cause personal injury.

Keep your hands, feet, face, clothing, and other body parts away from the muffler and other hot surfaces.

Engine Safety

Shut off the engine before checking the oil or adding oil to the crankcase.

Servicing the Air Cleaner

Service Interval: Every 150 hours

Every 250 hours—Replace the primary air filter (more often in dusty or sandy conditions).

Every 250 hours—Check the safety air filter.

Every 500 hours—Replace the safety air filter.

Note: Check the filters more frequently if the operating conditions are extremely dusty or sandy.

Removing the Filters

1. Disengage the blade-control switch (PTO), move the motion-control levers to the NEUTRAL-LOCK position, and engage the parking brake.
2. Shut off the engine, remove the key, and wait for all moving parts to stop before leaving the operating position.
3. Release the latches on the air cleaner and pull the air-cleaner cover off the air-cleaner body (Figure 29).

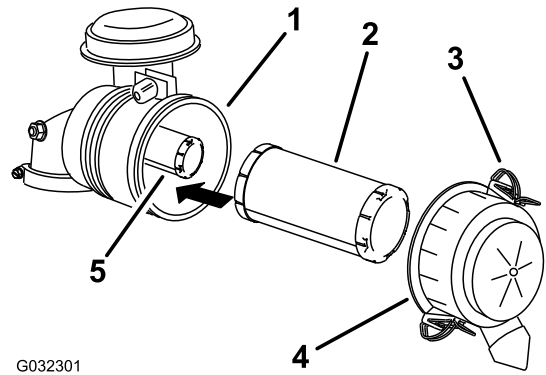

Figure 29

- | | |
|---------------------|----------------------|
| 1. Air-cleaner body | 4. Air-cleaner cover |
| 2. Primary filter | 5. Safety filter |
| 3. Latch | |

4. Clean the inside of the air-cleaner cover with compressed air.
5. Gently slide the primary filter out of the air-cleaner body (Figure 29).

Note: Avoid knocking the filter into the side of the body.

6. Remove the safety filter only if you intend to replace it.

Important: Do not attempt to clean the safety filter. If the safety filter is dirty, then the primary filter is damaged. Replace both filters.

7. Inspect the primary filter for damage by looking into the filter while shining a bright light on the outside of the filter.

Note: Holes in the filter appear as bright spots. If the filter is damaged, discard it.

Servicing the Primary Filter

- If the primary filter is dirty, bent, or damaged, replace it.
- Do not clean the primary filter.

Servicing the Safety Filter

Replace the safety filter, never clean it.

Important: Do not attempt to clean the safety filter. If the safety filter is dirty, then the primary filter is damaged. Replace both filters.

Installing the Filters

Important: To prevent engine damage, always operate the engine with both air filters and the cover installed.

1. If installing new filters, check each filter for shipping damage.
Note: Do not use a damaged filter.
2. If you are replacing the safety filter, carefully slide it into the filter body (Figure 29).
3. Carefully slide the primary filter over the safety filter (Figure 29).

Note: Ensure that the primary filter is fully seated by pushing on its outer rim while installing it.

Important: Do not press on the soft inside area of the filter.

4. Install the air-cleaner cover with the side indicated as **up** facing upward and secure the latches (Figure 29).

Servicing the Engine Oil

Oil Type: Detergent oil (API service class SJ or higher)

Oil Capacity: with a filter change, 1.8 L (61 fl oz); with no filter change, 1.6 L (54 fl oz)

Viscosity: See the table below.

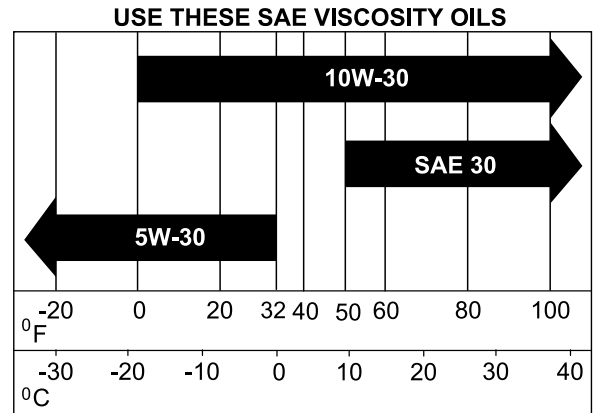

Figure 30

Checking the Engine-Oil Level

Service Interval: Before each use or daily

Note: Check the oil when the engine is cold.

Important: Do not overfill the crankcase with oil because damage to the engine may result. Do not run engine with oil below the low mark because the engine may be damaged.

1. Move the speed-control lever to the NEUTRAL position to stop the machine.
2. Disengage the PTO, engage the parking brake, shut off the engine, and wait for all moving parts to stop.
3. Allow the engine to cool.
4. Raise the hopper
5. Clean the area around the dipstick (Figure 31).
6. Remove the dipstick and wipe the oil off.
7. Insert the dipstick and push it all the way down into the tube.
8. Remove the dipstick and read the oil level.
9. If the oil level is low, wipe off the area around the oil-fill cap, remove cap and fill to the **full** mark on the dipstick (Figure 31).

Important: Do not operate the engine with the oil level below the low (or add) mark on the dipstick or over the full mark.

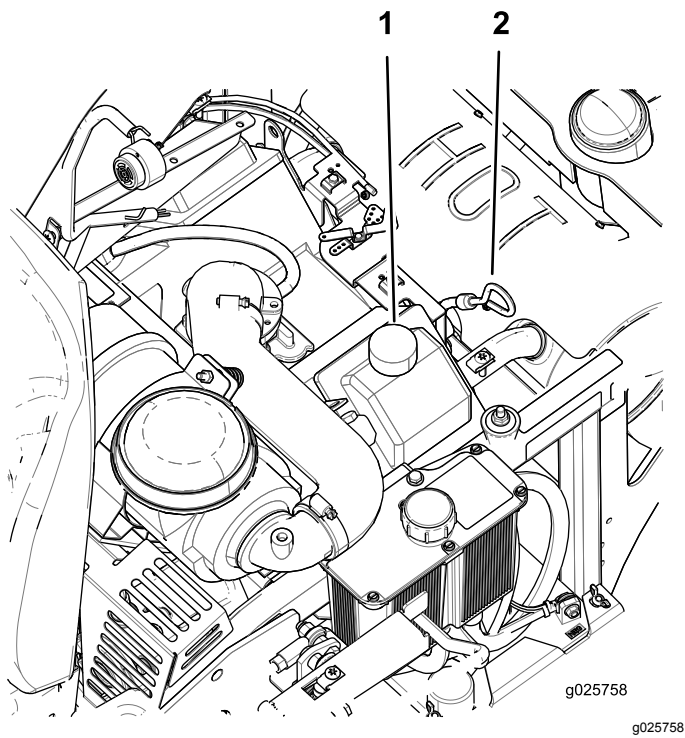

Figure 31

1. Oil-fill cap

2. Oil dipstick

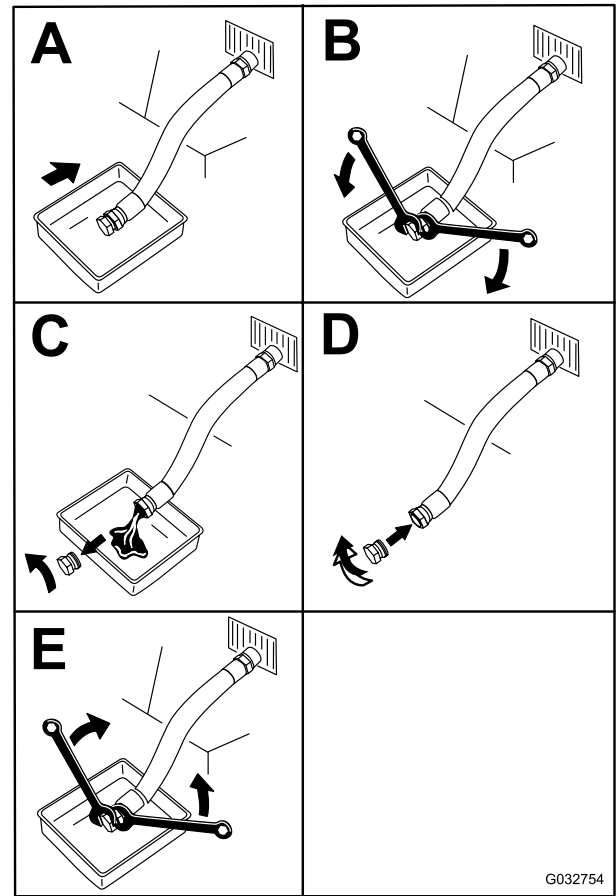

Figure 32

Changing the Engine Oil

Service Interval: Every 100 hours (more often in dirty or dusty conditions).

Note: Dispose of the used oil at a recycling center.

1. Park the machine so that the rear is slightly lower than the front to ensure that the oil drains completely.
2. Move the speed-control lever to the NEUTRAL position to stop the machine.
3. Disengage the PTO, engage the parking brake, shut off the engine, and wait for all moving parts to stop.
4. Slowly pour approximately 80% of the specified oil into the filler tube and slowly add the additional oil to bring it to the **full** mark on the dipstick (Figure 31).
5. Start the engine and drive to a flat area. Wait 3 minutes for oil to settle into the crankcase. Check the oil level again (Figure 31).
6. If needed, add oil to the **full** mark on the dipstick.

Changing the Engine-Oil Filter

Service Interval: Every 200 hours

Note: Change the engine-oil filter more frequently when operating conditions are extremely dusty or sandy.

1. Drain the oil from the engine; refer to [Changing the Engine Oil \(page 35\)](#).
2. Change the engine-oil filter ([Figure 33](#)).

Note: Allow 2 minutes for the new oil to be absorbed by the new filter material.

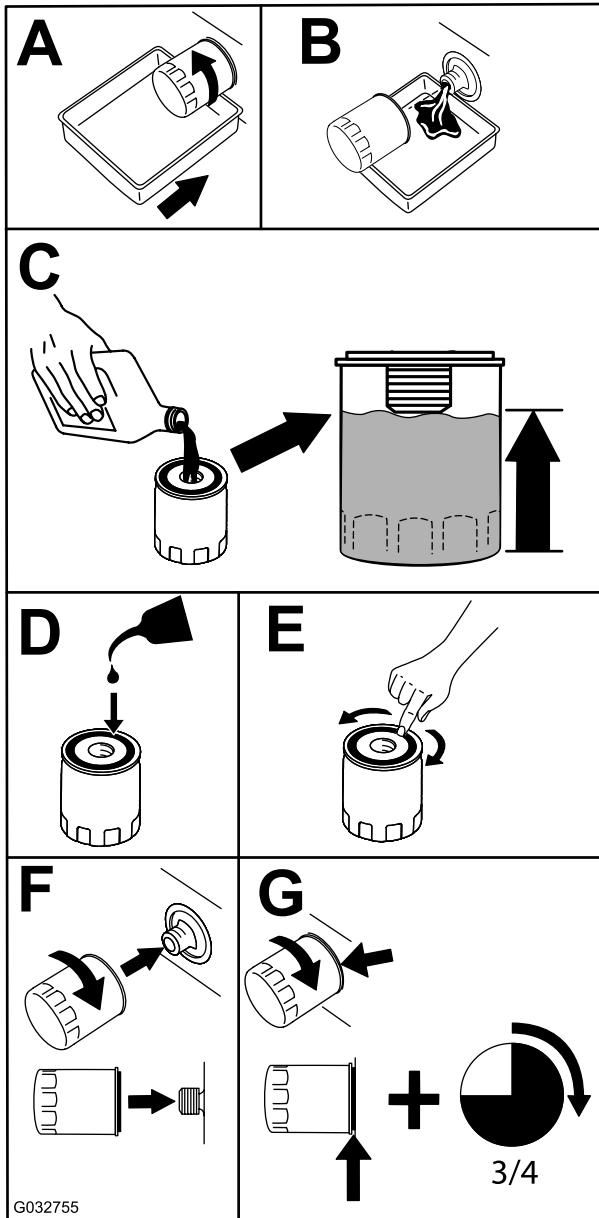

Figure 33

Note: Ensure the oil filter gasket touches the engine and then an extra 3/4 turn is completed.

3. Fill the crankcase with the proper type of new oil; refer to [Changing the Engine Oil \(page 35\)](#).

Servicing the Spark Plugs

Service Interval: Every 500 hours—Check and gap the spark plug.

Make sure that the air gap between the center and side electrodes is correct before installing the spark plugs. Use a spark-plug wrench for removing and installing the spark plugs and a gapping tool/feeler gauge to check and adjust the air gap. Install new spark plugs if necessary.

Type: Champion® RC12YC or equivalent

Air Gap: 0.76 mm (0.030 inch)

Removing the Spark Plugs

1. Move the speed-control lever to the NEUTRAL position to stop the machine.
2. Disengage the PTO, engage the parking brake, shut off the engine, and wait for all moving parts to stop.
3. Remove the spark plugs.

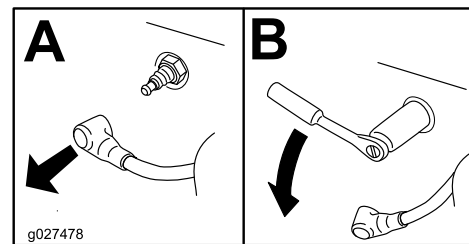

Figure 34

Checking the Spark Plugs

Important: Replace the spark plugs when they have: a black coating, worn electrodes, an oily film, cracks or reuse is questionable.

If you see light brown or gray on the insulator, the engine is operating properly. A black coating on the insulator usually means that the air cleaner is dirty.

Set the gap to 0.76 mm (0.030 inch).

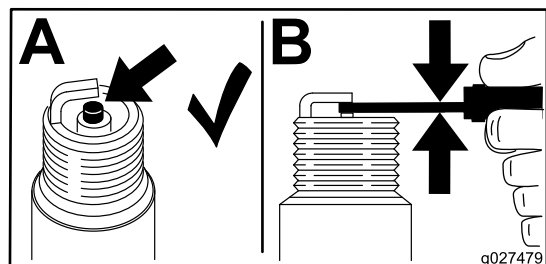

Figure 35

Installing the Spark Plugs

Tighten the spark plugs to 24.4 to 29.8 N·m (18 to 22 ft-lb).

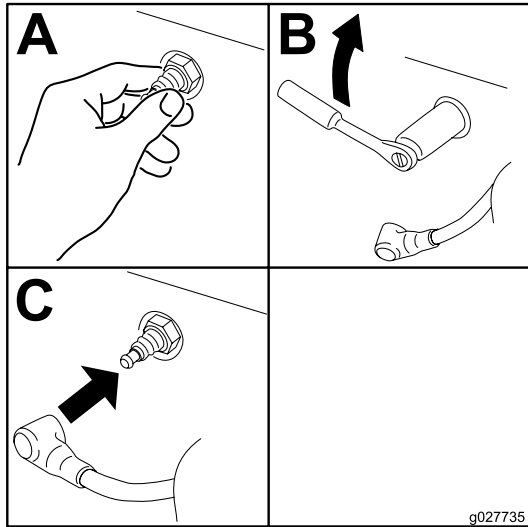

Figure 36

g027735

Checking the Spark Arrester

For a Model with a Spark Arrester

Service Interval: Every 50 hours

⚠ WARNING

Hot exhaust system components may ignite fuel vapors even you shut off the engine. Hot particles exhausted during engine operation may ignite flammable materials. Fire may result in personal injury or property damage.

Do not refuel or run the engine unless a spark arrester is installed.

1. Shut off the engine, wait for all moving parts to stop, and remove the key. Engage the parking brake.
2. Wait for the muffler to cool.
3. If there are any breaks in the screen or welds, replace the arrestor.
4. If the screen is plugged, remove the arrestor and shake the loose particles out of the arrestor and clean the screen with a wire brush (soak it in solvent if necessary). Install the arrestor on the exhaust outlet.

Fuel System Maintenance

⚠ WARNING

Fuel system components are under high pressure. The use of improper components can result in system failure, fuel leakage, and possible explosion.

Use only approved fuel lines and fuel filters.

Replacing the Fuel Filter

Service Interval: Every 200 hours/Yearly (whichever comes first) (more often in dirty or dusty conditions).

The fuel filter is located near the engine on the front or rear side of the engine.

1. Move the speed-control lever to the NEUTRAL position to stop the machine.
2. Disengage the PTO, engage the parking brake, shut off the engine, and wait for all moving parts to stop.
3. Wait for the machine to cool down.
4. Clamp the hose on the fuel tank side of the fuel filter.
5. Squeeze the ends of the hose clamps together and slide them away from the filter (Figure 37).

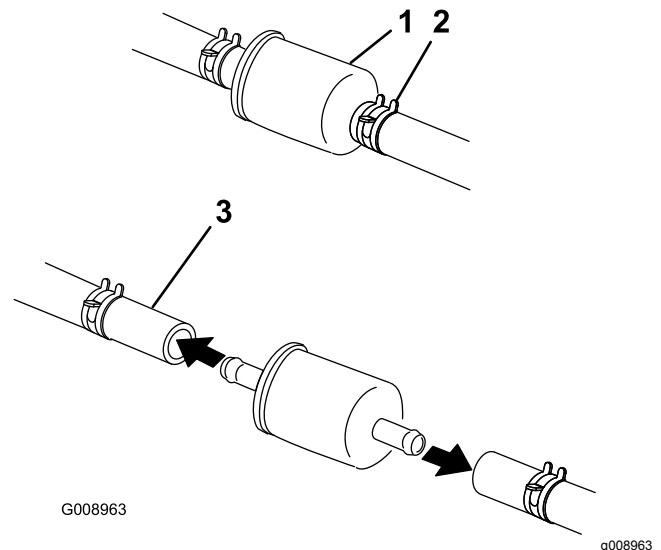

Figure 37

1. Fuel filter
2. Hose clamp
3. Fuel line

6. Remove the filter from the fuel lines.
7. Install a new filter and move the hose clamps close to the filter (Figure 37).

8. Open the fuel-shutoff valve.

Note: Install the fuel-line hoses and secure them with plastic ties the same as they were originally installed at the factory to keep the fuel line away from components that could cause fuel line damage.

Servicing the Fuel Tank

Do not attempt to drain the fuel tank. Ensure that an Authorized Service Dealer drains the fuel tank.

Electrical System Maintenance

Electrical System Safety

- Disconnect the battery before repairing the machine. Disconnect the negative terminal first and the positive last. Connect the positive terminal first and the negative last.
- Charge the battery in an open, well-ventilated area, away from sparks and flames. Unplug the charger before connecting or disconnecting the battery. Wear protective clothing and use insulated tools.

WARNING

CALIFORNIA Proposition 65 Warning

Battery posts, terminals, and related accessories contain lead and lead compounds, chemicals known to the State of California to cause cancer and reproductive harm. Wash hands after handling.

Servicing the Battery

Service Interval: Monthly

⚠ DANGER

Battery electrolyte contains sulfuric acid, which is fatal if consumed and causes severe burns.

- Do not drink electrolyte and avoid contact with skin, eyes or clothing. Wear safety glasses to shield your eyes and rubber gloves to protect your hands.
- Fill the battery where clean water is always available for flushing the skin.

Removing the Battery

⚠ WARNING

Battery terminals or metal tools could short against metal machine components causing sparks. Sparks can cause the battery gases to explode, resulting in personal injury.

- When removing or installing the battery, do not allow the battery terminals to touch any metal parts of the machine.
- Do not allow metal tools to short between the battery terminals and metal parts of the machine.

⚠ WARNING

Incorrect battery cable routing could damage the machine and cables and cause sparks. Sparks can cause the battery gasses to explode, resulting in personal injury.

- Always disconnect the negative (black) battery cable before disconnecting the positive (red) cable.
 - Always connect the positive (red) battery cable before connecting the negative (black) cable.
1. Move the speed-control lever to the NEUTRAL position to stop the machine.
 2. Disengage the PTO, engage the parking brake, shut off the engine, and wait for all moving parts to stop.
 3. Disconnect the negative battery cable (black) from the negative (-)(black) battery terminal (Figure 38).
 4. Slide the red terminal boot off the positive (red) battery terminal and remove the positive (+)(red) battery cable (Figure 38).
 5. Remove the wing nuts securing the J-hooks (Figure 38).
 6. Remove the clamp (Figure 38).
 7. Remove the battery.

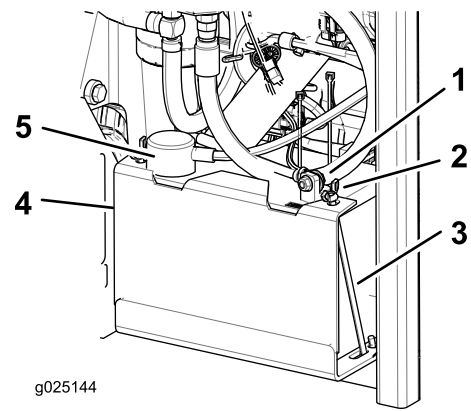

Figure 38

1. Negative (black) battery cable
2. Wing nut
3. J-hook
4. Clamp
5. Positive (red) battery cable

Installing the Battery

1. Position the battery in the tray with the terminal posts opposite from the hydraulic tank (Figure 38).
2. Install the positive (red) battery cable to the positive (+) battery terminal.
3. Install the negative (black) battery cable and ground wire to the negative (-) battery terminal.
4. Secure the cables with 2 bolts, 2 washers, and 2 locknuts (Figure 38).
5. Slide the red terminal boot onto the positive (red) battery post.
6. Install the clamp and secure it with the wing nuts and J-hooks (Figure 38).

Charging the Battery

⚠ WARNING

Charging the battery produces gases that can explode.

Never smoke near the battery and keep sparks and flames away from battery.

Important: Always keep the battery fully charged (1.265 specific gravity). This is especially important to prevent battery damage when the temperature is below 0°C (32°F).

1. Charge battery for 10 to 15 minutes at 25 to 30 A or 30 minutes at 10 A.
2. When the battery is fully charged, unplug the charger from the electrical outlet; then disconnect the charger leads from the battery posts (Figure 39).

3. Install the battery in the machine and connect the battery cables, refer to [Installing the Battery \(page 39\)](#).

Note: Do not run the machine with the battery disconnected; electrical damage may occur.

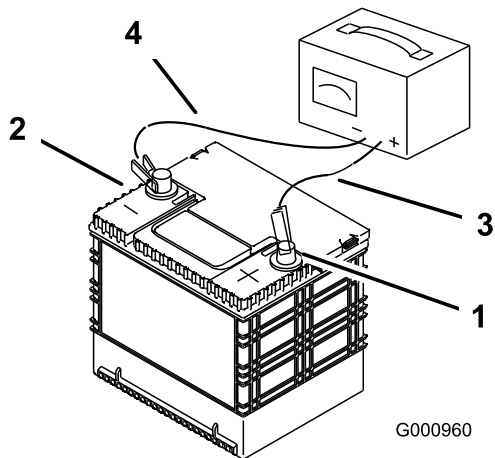

Figure 39

- | | |
|--------------------------|---------------------------|
| 1. Positive battery post | 3. Red (+) charger lead |
| 2. Negative battery post | 4. Black (-) charger lead |

Servicing the Fuses

The electrical system is protected by fuses. It requires no maintenance; however, if a fuse blows check the component/circuit for a malfunction or short.

1. The fuses are located on right side behind the seat.
2. To replace the fuses, pull out on the fuse to remove it.
3. Install a new fuse.

Adjusting the Safety Switches

Adjust all safety switches so that the plunger extends 4.8 mm to 6.4 mm (3/16 inch to 1/4 inch) from the switch body when the plunger is compressed ([Figure 40](#)).

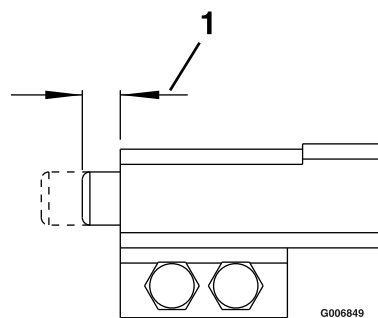

Figure 40

1. 4.8 to 6.4 mm (3/16 to 1/4 inch)

Drive System Maintenance

Adjusting the Tracking

Note: The tracking knob is located under the seat.

Note: Rotating this knob allows fine tuning adjustments so that the machine tracks straight with the drive levers in the full forward position.

1. Run the machine at 3/4 speed for at least 5 minutes to bring hydraulic fluid up to operating temperature. Stop machine and wait for all moving parts to stop.
2. Engage the parking brake.
3. Tilt the seat forward to gain access to the tracking knob.
4. Rotate the knob toward the right to steer right and rotate it toward the left to steer left.
5. Adjust in 1/8 turn increments until the machine tracks straight.
6. Check and ensure that the machine does not creep when in neutral with the parking brakes disengaged (Figure 41).

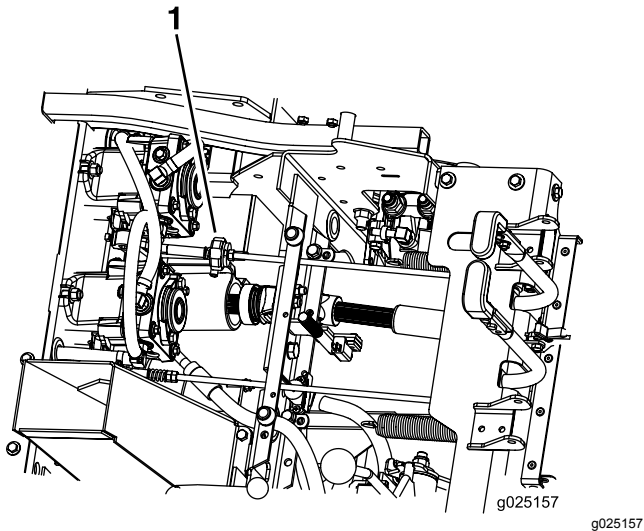

Figure 41

1. Tracking knob

Checking the Tire Pressure

Service Interval: Every 40 hours

Maintain the air pressure in the rear tires at 103 kPa (15 psi). Uneven tire pressure can cause uneven cut. Check the tires when they are cold, to get the most accurate pressure reading.

Note: The front tires are semi-pneumatic tires and does not require air pressure maintenance.

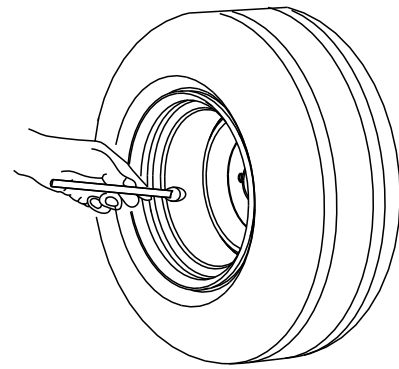

G001055

g001055

Figure 42

Note: Do not add any type of tire liner or foam fill material to the tires.

Checking the Wheel-Lug Nuts

Service Interval: After the first 100 hours

Every 500 hours

Check and torque the wheel-lug nuts to 122 to 129 N·m (90 to 95 ft-lb).

Checking the Wheel-Hub Nuts

Service Interval: After the first 100 hours

Every 500 hours

Check and ensure that the torque of the slotted nut is 373 to 475 N·m (275 to 350 ft-lb).

Adjusting the Caster-Pivot Bearings

Service Interval: Every 500 hours/Yearly (whichever comes first)

1. Move the speed-control lever to the NEUTRAL position to stop the machine.
2. Disengage the PTO, engage the parking brake, shut off the engine, and wait for all moving parts to stop.
3. Remove the dust cap from the caster and tighten the locknut (Figure 43 and Figure 44).

- Tighten the locknut until the spring washers are flat and then back off 1/4 turn to properly set the pre-load on the bearings (Figure 43 and Figure 44).

Important: Make sure that the spring washers are installed correctly as shown in Figure 43 and Figure 44.

- Install the dust cap.

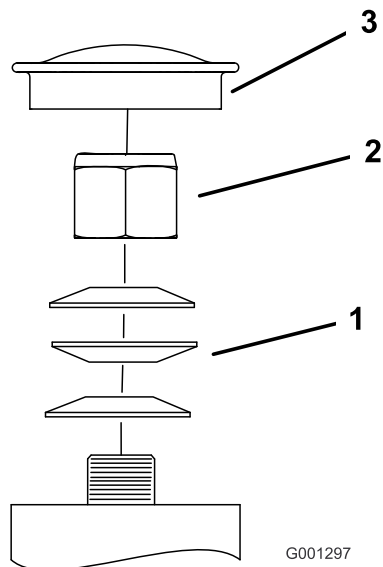

Figure 43
Front Caster

- | | |
|-------------------|-------------|
| 1. Spring washers | 3. Dust cap |
| 2. Locknut | |

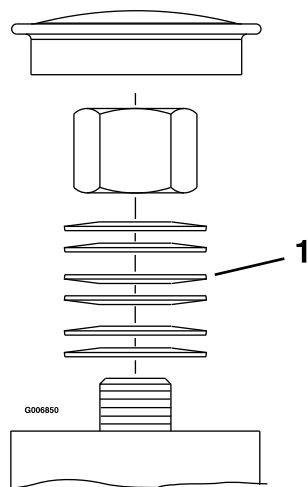

Figure 44
Rear Caster

- Spring washers

Cooling System Maintenance

Cleaning the Engine Screen and Engine Oil Cooler

Service Interval: Before each use or daily

Remove any buildup of grass, dirt, or other debris from the oil cooler.

Before each use remove any buildup of grass, dirt, or other debris from the engine screen. This helps ensure adequate cooling and correct engine speed and reduces the possibility of overheating and mechanical damage to the engine.

Servicing the Engine-Oil Cooler

Service Interval: Every 100 hours

- Move the speed-control lever to the NEUTRAL position to stop the machine.
- Disengage the PTO, engage the parking brake, shut off the engine, and wait for all moving parts to stop.
- Remove the fuel-tank mounting nuts and swing out the fuel tank.
- Keep the oil cooler free of debris by cleaning the fins with a brush.
- Swing the fuel tank in and secure it with the mounting nuts.
- Back the mounting nuts off 1/2 turn to allow for tank expansion.

Cleaning the Engine Cooling Fins and Shrouds

Service Interval: Every 100 hours/Yearly (whichever comes first)

- Move the speed-control lever to the NEUTRAL position to stop the machine.
- Disengage the PTO, engage the parking brake, shut off the engine, and wait for all moving parts to stop.
- Remove the air-intake screen and fan housing.
- Clean the debris and grass from the engine parts.
- Install air-intake screen and fan housing.

Checking and Cleaning the Hydraulic Pumps

Service Interval: Before each use or daily

1. Move the speed-control lever to the NEUTRAL position to stop the machine.
2. Disengage the PTO, engage the parking brake, shut off the engine, and wait for all moving parts to stop.
3. Raise the seat.
4. Clean the debris and grass from the hydraulic pumps.
5. Lower the seat.

Brake Maintenance

Adjusting the Parking Brake

Service Interval: After the first 100 hours

Every 500 hours thereafter

Make sure that the brake is adjusted properly. Follow this procedure when you remove or replace a brake component.

1. Stop the machine and move the speed-control lever to the NEUTRAL position.
2. Disengage the PTO, engage the parking brake, shut off the engine, and wait for all moving parts to stop.
3. Release the parking brake.
4. Tilt the seat forward.
5. Check and ensure there is no slack between the parking-brake handle and the linkage.
6. If an adjustment is necessary, remove the clevis pin and rotate the linkage counterclockwise to lengthen it or clockwise to shorten it.

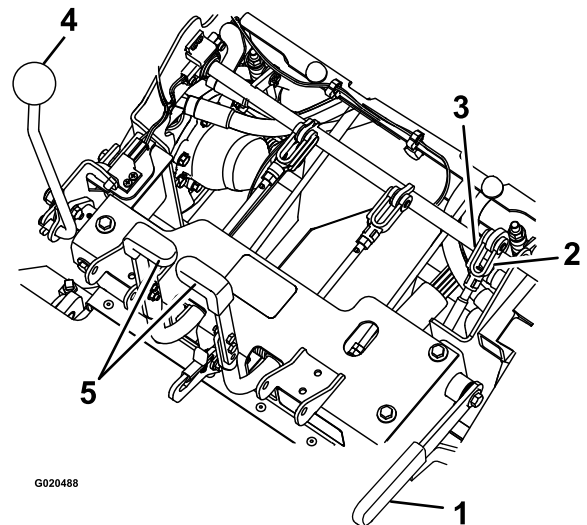

Figure 45

- | | |
|------------------|------------------------|
| 1. Parking brake | 4. Speed-control lever |
| 2. Rotate yoke | 5. Steering levers |
| 3. Clevis pin | |

7. Measure the compressed spring length on both vertical spring assemblies.

Note: The spring should measure between 6 to 7 cm (2.35 to 2.85 inches). If necessary, adjust the nut at the top of the vertical spring assembly to achieve this distance.

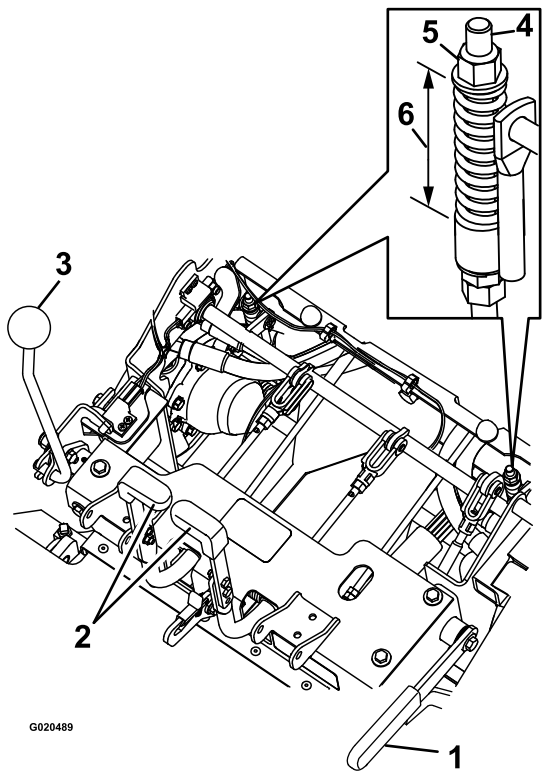

Figure 46

- | | |
|------------------------|------------------------------------|
| 1. Parking brake | 4. Vertical spring assembly |
| 2. Steering lever | 5. Nut |
| 3. Speed-control lever | 6. 6 to 7 cm (2.35 to 2.85 inches) |

- Adjust the linkage length with the 2 nuts at the bottom of the vertical spring assembly (Figure 47).

Note: The linkage should measure 22.7 to 23.3 cm (8.92 to 9.16 inches).

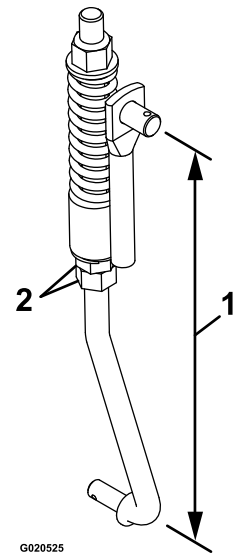

Figure 47

- 22.7 to 23.3 cm (8.92 to 9.16 inches)
- Nuts

- Engage and disengage the brakes to check for proper engagement and disengagement. Adjust if necessary.

Note: When the brakes are disengaged, there should be little to no free play in the brake linkage with no dragging in the brakes.

Belt Maintenance

Inspecting the Belts

Service Interval: Every 40 hours

1. Stop the machine and move the speed-control lever to the NEUTRAL position.
2. Disengage the PTO, engage the parking brake, shut off the engine, and wait for all moving parts to stop.
3. Tilt the hopper up and check the pump and PTO drive belts for wear, cracking, or contamination.

Note: The belts are spring tensioned and no adjustment is necessary unless you replace the belts.

Replacing the PTO Belts

1. Stop the machine and move the speed-control lever to the NEUTRAL position.
2. Disengage the PTO, engage the parking brake, shut off the engine, and wait for all moving parts to stop.
3. With the engine off, engage the PTO lever, then remove the hairpin cotter and clevis pin at the bottom of the PTO-brake band.
4. Rotate the brake band upward and out of the way of the belts keeping clear of the belt drive.
5. Disengage the PTO lever.
6. Loosen belt guides **A** and **B** (Figure 48).
7. Remove the belts.
8. Route the new belts onto the pulleys as shown in Figure 48.

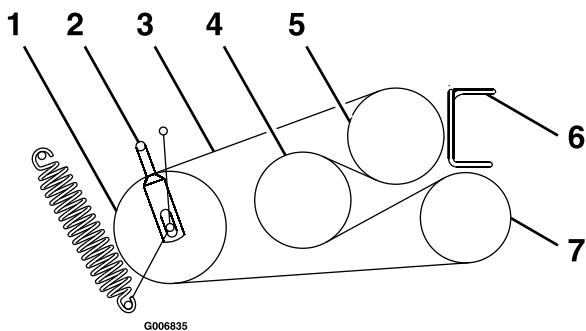

Figure 48

1. Idler
2. Belt guide **B**
3. PTO belt
4. Jackshaft
5. Engine
6. Belt guide **A**
7. Blower

10. Rotate the brake band down into the original position.
11. Install the clevis pin and hairpin cotter to secure the brake band.
12. Engage the PTO lever.
13. Loosen the jam nuts and adjust the linkage until the top of the idler arm is aligned with the bottom of the notch on the tension arm as shown in Figure 49.

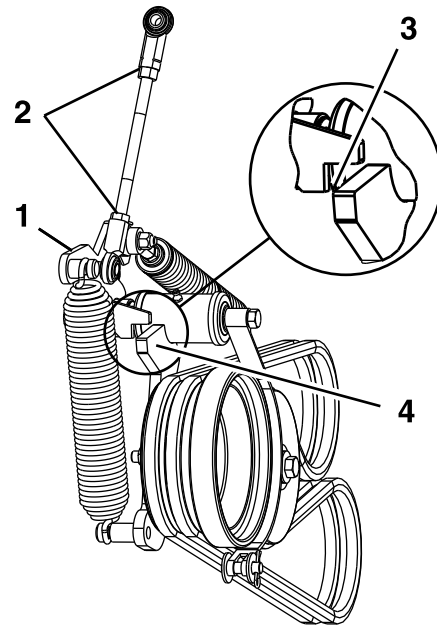

Figure 49

1. Tension arm
2. Loosen the jam nuts.
3. When PTO is engaged, align top of idler arm with bottom of notch on tension arm, as shown.
4. Idler arm

14. Tighten the jam nuts and disengage the PTO lever.
15. Engage the PTO lever and check the alignment.
16. Check and adjust the belt guides as stated in [Adjusting the Belt Guides \(page 46\)](#).

9. Engage the PTO lever.

Replacing the Pump-Drive Belt

1. Stop the machine and move the speed-control lever to the NEUTRAL position.
2. Disengage the PTO, engage the parking brake, shut off the engine, and wait for all moving parts to stop.
3. Remove the PTO Belts; refer to [Replacing the PTO Belts \(page 45\)](#).
4. Pull the spring idler or remove the spring to relieve the tension of the pump-drive belt.
5. Remove the old belt.
6. Route the new belt onto the sheaves as shown in the decal located on the back of the left drive shield ([Figure 50](#)).

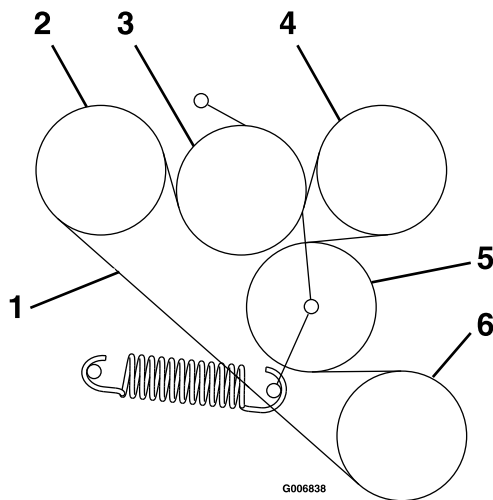

Figure 50

- | | |
|--------------------|-----------|
| 1. Pump-drive belt | 4. Pump |
| 2. Pump | 5. Idler |
| 3. Idler | 6. Engine |

Adjusting the Belt Guides

1. Stop the machine and move the speed-control lever to the NEUTRAL position.
2. Disengage the PTO, engage the parking brake, shut off the engine, and wait for all moving parts to stop.
3. With the engine off, engage the PTO lever.
4. Adjust the belt guides as shown in [Figure 51](#).

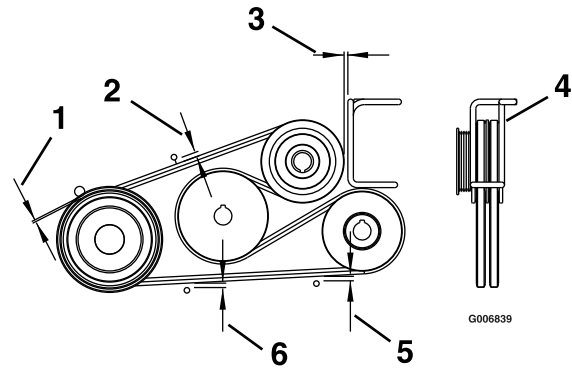

Figure 51

- | | |
|------------------------------|--|
| 1. 3 mm (1/8 inch) | 4. Rotate the wireform guide to the center belts in the guide. |
| 2. 11 mm (7/16 inch) | 5. 6 mm (1/4 inch) |
| 3. 3 mm (1/8 inch) clearance | 6. 8 mm (5/16 inch) |

7. Install the PTO belts; refer to [Replacing the PTO Belts \(page 45\)](#).

Controls System Maintenance

Adjusting the Reverse-Stop Rod

1. Stop the machine and move the speed-control lever to the NEUTRAL position.
2. Disengage the PTO, engage the parking brake, shut off the engine, and wait for all moving parts to stop.
3. Check the movement of the steering levers as follows:
 - If the levers move slightly forward up to 3 mm (1/8 inch) then no adjustment is necessary.
 - If the levers do not move, then proceed with the following steps:
 - A. Flip the seat up or remove the seat-frame assembly (with the seat attached) to obtain a clear view of the steering-control shaft to complete this adjustment.
 - B. Place the speed-control lever in the NEUTRAL position.
 - C. Release the parking brake.
 - D. Slightly adjust the length of the rod by loosening the jam nut and by rotating the rod.

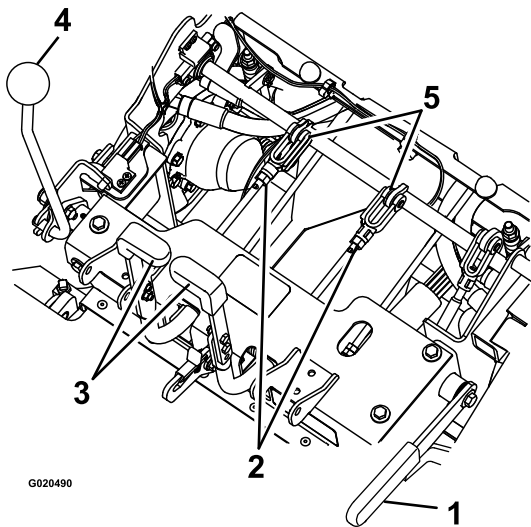

Figure 52

- | | |
|-------------------|----------------------------|
| 1. Parking brake | 4. Speed-control lever |
| 2. Nut | 5. Clevis pin and stop rod |
| 3. Steering lever | |

- F. Repeat steps C through E until you achieve up to 3 mm (1/8 inch) movement.
- G. Install the seat frame assembly, if removed in step A.

Adjusting the Speed-Control Lever Tension

1. Stop the machine and move the speed-control lever to the NEUTRAL position.
2. Disengage the PTO, engage the parking brake, shut off the engine, and wait for all moving parts to stop.
3. To adjust the tension, adjust the pivot nut, which is located at the end of the motion-control shaft in front of the right console (Figure 53).

Note: Set the tension high enough that the speed-control lever position is maintained during operation and loose enough to be moved comfortably.

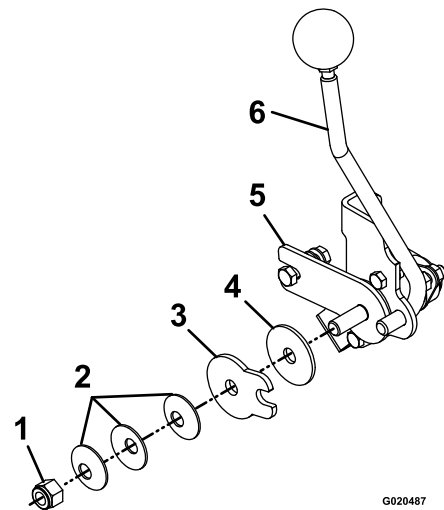

Figure 53

- | | |
|---------------------------------|-----------------------------------|
| 1. Pivot nut | 4. Friction disc |
| 2. Spring-disc washers | 5. Speed-control friction bracket |
| 3. Speed-control friction plate | 6. Speed-control lever |

- E. Engage the parking brake and check the steering levers.

Adjusting the Speed-Control Linkage

⚠ WARNING

The engine must be running and the drive wheels must be turning to adjust the motion controls. Contact with moving parts or hot surfaces may cause personal injury.

Keep your fingers, hands, and clothing clear of rotating components and hot surfaces.

⚠ CAUTION

Raising the mower deck for service or maintenance relying solely on mechanical or hydraulic jacks could be dangerous. The mechanical or hydraulic jacks may not be enough support or may malfunction allowing the unit to fall, which could cause injury.

Do not rely solely on mechanical or hydraulic jacks for support. Use adequate jack stands or equivalent support.

1. Stop the machine and move the speed-control lever to the NEUTRAL position.
2. Disengage the PTO, engage the parking brake, shut off the engine, and wait for all moving parts to stop.
3. Remove the electrical connection from the seat safety switch, located directly in front of the seat-switch assembly.
4. Raise the frame and place on jack stands so that drive wheels can rotate freely.
Note: You must make the neutral adjustment with the drive wheels turning.
5. Temporarily install a jumper wire across the terminals in the connector of the wiring harness.
6. Start the engine.
7. Run the machine at least 5 minutes with the speed-control lever at full forward speed to bring the hydraulic system oil up to operating temperature.
8. Return the speed-control lever to the NEUTRAL position.
9. To obtain the NEUTRAL position, adjust the left and right pump-control-rod linkages that connect the steering control to the pump-control arms until the wheels stop or creep slightly in reverse (Figure 54).
10. Adjust the left pump linkage by rotating the tracking-adjustment knob.

11. Adjust the right pump linkage by using a wrench to turn the double nuts on the assembly (Figure 54).

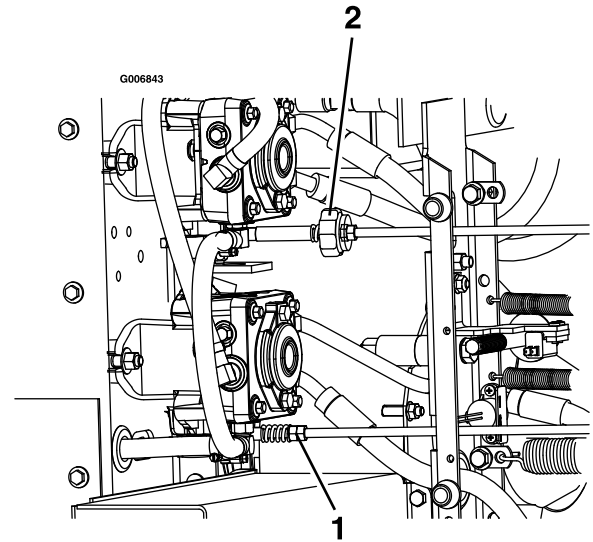

Figure 54

1. Rotate the tracking knob on left side.
 2. Rotate the double nuts on right side.
-
12. Move the steering levers to the reverse position. While applying slight pressure to the levers, allow the steering levers to return to NEUTRAL.
Note: The wheels must stop turning or slightly creep in reverse.
 13. Shut off the engine and wait for all moving parts to stop.
 14. Remove the jumper wire from the wire-harness connector and plug the connector into the seat switch.
 15. Lower the machine from the jackstands.

Aligning the PTO-Drive Pulley

Align the PTO-drive pulley for any of the following conditions:

- The blower has been removed or replaced.
 - The engine mounting bolts have been loosened or the engine has been moved or replaced.
 - The jackshaft mounting bolts have been loosened or the jackshaft has been moved or replaced.
1. Stop the machine and move the speed-control lever to the NEUTRAL position.
 2. Disengage the PTO, engage the parking brake, shut off the engine, and wait for all moving parts to stop.

3. Remove the fuel-tank mounting nuts and swing out the fuel tank.
4. Verify that the blower is installed and tightly secured.
5. Loosen the 4 engine mounting bolts.
6. Unhook the pump-belt tension spring.
7. Loosen the 4 jackshaft mounting bolts.
8. Measuring from the blower pulley as a baseline, move the engine and jackshaft until the rear surface of all 3 pulleys are aligned within 0.8 to 1.6 mm (1/32 inch to 1/16 inch) (Figure 55).

Note: Use a straight edge to align all 3 surfaces.

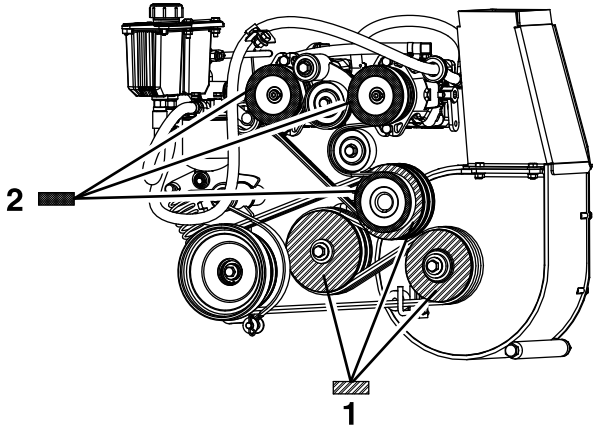

Figure 55

g006846

1. Align the 3 pump-drive pulley surfaces shown with this pattern within 0.8 to 1.6 mm (1/32 inch to 1/16 inch).
2. Align the 3 PTO-drive pulley surfaces shown with this pattern within 0.8 to 1.6 mm (1/32 inch to 1/16 inch).

9. Tighten the 4 engine mounting bolts and 4 jackshaft mounting bolts. Check the alignment after tightening.
10. Install the pump-belt tension spring.
11. Swing the fuel tank in and install the tank mounting nuts.
12. Align the pump-drive pulley; [Aligning the Pump-Drive Pulley \(page 49\)](#).

Aligning the Pump-Drive Pulley

The pump-drive-pulley alignment is necessary for any of the following conditions:

- The engine mounting bolts have been loosened or the engine has been moved or replaced.
- The pump pulleys have been loosened, moved, or replaced.
- The PTO pulley has been aligned; refer to [Aligning the PTO-Drive Pulley \(page 48\)](#).

1. Shut off the machine and move the speed-control lever to the NEUTRAL position.
2. Disengage the PTO, engage the parking brake, shut off the engine, and wait for all moving parts to stop.
3. Loosen the set screws on both pump pulleys.
4. Using a straight edge, align each pump pulley with the engine pulley by sliding it along the pump shaft (Figure 55).
5. Tighten the pulley set screws and check the alignment.

Adjusting the PTO Brake Spring

Adjust the PTO brake spring only if the blower has been removed or replaced or if the PTO drive idler arm has been disassembled.

1. Stop the machine and move the speed-control lever to the NEUTRAL position.
2. Disengage the PTO, engage the parking brake, shut off the engine, and wait for all moving parts to stop.
3. Locate the brake spring and thread the 2 jam nuts out to the end of the brake-spring rod (Figure 56).
4. Tighten the jam nuts together at end of the brake-spring rod.

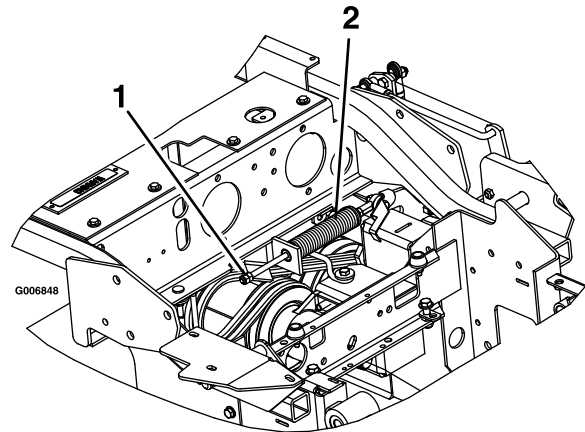

Figure 56

g006848

1. Tighten the jam nuts here.
2. PTO brake-spring assembly

Adjusting the Hopper Door

1. Stop the machine and move the speed-control lever to the NEUTRAL position.
2. Disengage the PTO, engage the parking brake, shut off the engine, and wait for all moving parts to stop.
3. Loosen the 6 door hinge nuts (Figure 57).
4. Open the door and place a 3/8 inch (9.5 mm) rubber strip or 3/8 inch (9.5 mm) diameter hose between the hopper and the hopper door (Figure 57).
5. Close the door and push it tight against the hopper.
6. Tighten the hinge hardware.
7. Open the hopper door and remove the rubber strip.

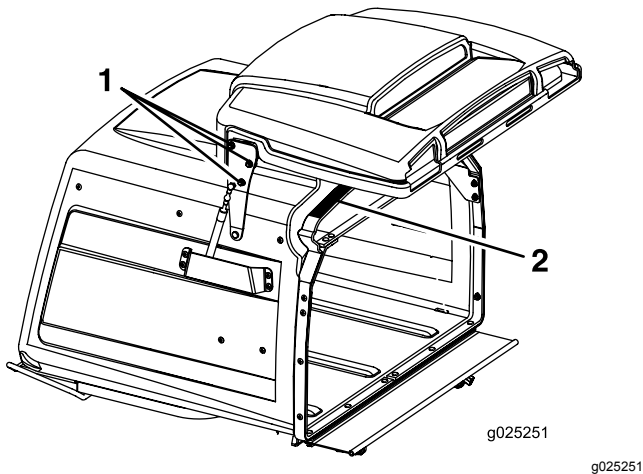

Figure 57

1. Loosen the door hinge nuts—3 per side.
2. Place a piece of 9.5 mm (3/8 inch) rubber on this surface.

Adjusting the Locking-Pin Stop on the Mower Deck

1. Slide the mower-deck locking pins in on both sides of the mower deck and rotate them to lock the mower deck in the operation position.
2. Loosen the jam nut and turn the stop screw clockwise until the locking pin is tight and cannot be rotated by hand (Figure 58).

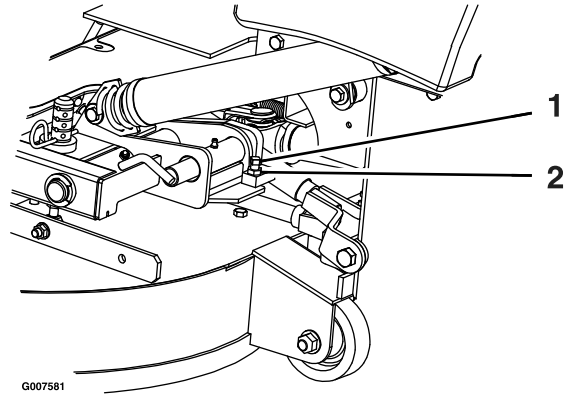

Figure 58

g007581

1. Rotate the stop screw clockwise until the locking pin is tight, then back off 1/2 turn.
 2. Loosen the jam nut.
-
3. Loosen the stop screw counter clockwise 1/2 turn and tighten the jam nut.
 4. Test the locking pin to make sure that it slides freely. Adjust it if necessary.

Hydraulic System Maintenance

Hydraulic System Safety

- Ensure that all hydraulic-fluid hoses and lines are in good condition and all hydraulic connections and fittings are tight before applying pressure to the hydraulic system.
- Keep your body and hands away from pinhole leaks or nozzles that eject high-pressure hydraulic fluid.
- Use cardboard or paper to find hydraulic leaks.
- Safely relieve all pressure in the hydraulic system before performing any work on the hydraulic system.
- Seek immediate medical attention if fluid is injected into skin. Injected fluid must be surgically removed within a few hours by a doctor.

Servicing the Hydraulic System

Hydraulic Fluid Type: Toro® HYPR-OIL™ 500 hydraulic oil or Mobil® 1 15W-50.

Important: Use the fluid specified. Other fluids could cause system damage.

Checking the Hydraulic Fluid

Service Interval: Every 40 hours—Check the hydraulic fluid level.

1. Position the machine on a level surface.
2. Move the speed-control lever to the NEUTRAL position to stop the machine.
3. Disengage the PTO, engage the parking brake, shut off the engine, and wait for all moving parts to stop.
4. Wait for the engine and the hydraulic system to cool for 10 minutes.

Note: To get the correct reading, check the hydraulic fluid level when the machine is cool.

5. Raise the seat up.
6. Clean the area around the dipstick of the hydraulic-system reservoir (Figure 59).
7. Remove the dipstick from the hydraulic reservoir (Figure 59).

8. Wipe the dipstick off and thread the dipstick into the reservoir.
9. Remove the dipstick and look at the end (Figure 59). If the fluid level is at the add mark, slowly pour only enough fluid into the hydraulic reservoir to raise the level to the full line.

Important: Do not overfill the hydraulic units with fluid, as damage may occur. Do not run the machine with the fluid below the add mark.

10. Install the dipstick.

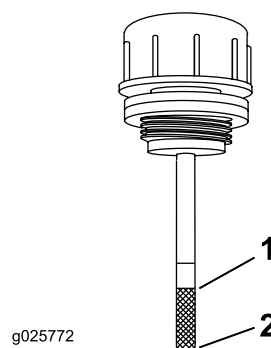

Figure 59

1. Full

2. Add

⚠ WARNING

Hydraulic fluid escaping under pressure can penetrate skin and cause injury.

- If hydraulic fluid is injected into the skin it must be surgically removed within a few hours by a doctor familiar with this type of injury or gangrene may result.
- Keep your body and hands away from pin-hole leaks or nozzles that eject high-pressure hydraulic fluid.
- Use cardboard or paper to find hydraulic leaks.
- Safely relieve all pressure in the hydraulic system before performing any work on the hydraulic system.
- Make sure that all hydraulic fluid hoses and lines are in good condition and all hydraulic connections and fittings are tight before applying pressure to hydraulic system.

Replacing the Hydraulic Filter

Service Interval: After the first 100 hours—Change the hydraulic filter and reservoir hydraulic fluid when using any type of fluid.

Every 250 hours—Change the hydraulic filter and reservoir hydraulic fluid when using Mobil® 1 fluid (more often in dirty or dusty conditions).

Every 500 hours—Change the hydraulic filter and reservoir hydraulic fluid when using Toro® HYPR-OIL™ 500 hydraulic fluid (more often in dirty or dusty conditions).

Note: Use a summer filter when the temperature is 0°C (32°F) and above. Use a winter filter when the temperature is 0°C (32°F) and below.

1. Move the speed-control lever to the NEUTRAL position to stop the machine.
2. Disengage the PTO, engage the parking brake, shut off the engine, and wait for all moving parts to stop.
3. Carefully clean the area around the filter.

Important: Ensure that no dirt or contamination enter the hydraulic system.

4. Unscrew and remove the filter and allow the fluid to drain from the reservoir.

Important: Do not change the hydraulic system fluid (except for what can be drained when changing the filter), unless the fluid has been contaminated or been extremely hot. Changing the hydraulic fluid unnecessarily could damage the hydraulic system by introducing contaminants into the system.

5. Before installing the new filter, fill it with Toro® HYPR-OIL™ 500 hydraulic fluid and apply a thin coat of fluid on the surface of the rubber seal.
6. Turn the filter clockwise until the rubber seal contacts the filter adapter, then tighten the filter an additional 2/3 to 3/4 turn.
7. Fill the reservoir as stated in [Checking the Hydraulic Fluid \(page 51\)](#).
8. Raise the rear of the machine up and support it with jack stands (or equivalent support) just high enough to allow drive wheels to turn freely.
9. Start the engine and move the throttle control to the FULL-THROTTLE position.
10. Move the speed-control levers to the full-speed position and run the machine for several minutes.
11. Shut off the machine and check the fluid level.

Mower Deck Maintenance

Leveling the Mower Deck

Setting up the Machine

Note: Ensure that the mower deck is leveled before matching the height of cut (HOC).

1. Position the machine on a flat surface.
2. Move the speed-control lever to the NEUTRAL position to stop the machine.
3. Disengage the PTO, engage the parking brake, shut off the engine, and wait for all moving parts to stop.
4. Check the tire pressure of the drive tires. If needed, adjust the pressure to 103 kPa (15 psi).

Leveling the Deck

1. Stop the machine and move the speed-control lever to the NEUTRAL position.
2. Disengage the PTO, engage the parking brake, shut off the engine, and wait for all moving parts to stop.
3. Verify that all hairpin cotters are in the 7.62 cm (3 inch) mower-deck-height holes with the spacers under the hairpin cotters ([Figure 60](#)).

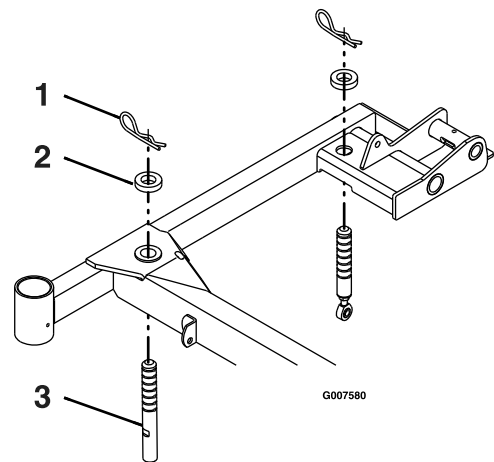

Figure 60
Right Side Shown

1. Hairpin cotter
2. Spacer
3. Mower-deck support pin
4. Shorten or lengthen each mower deck support pin to obtain blade tip height of 7.62 cm (3 inches) at the front of the deck and 8.26 cm (3 1/4 inches) at the rear of the deck ([Figure 60](#)).

Note: The front pins are thread into the mower deck and have a jam nut. The rear pins have a rod end threaded into them with a jam nut.

Servicing the Cutting Blades

To ensure a superior quality of cut, keep the blades sharp. For convenient sharpening and replacement, you may want to keep extra blades on hand.

⚠ DANGER

A worn or damaged blade can break, and a piece of the blade could be thrown at you or bystanders, resulting in serious personal injury or death.

- Inspect the blade periodically for wear or damage.
- Replace a worn or damaged blade.

Blade Safety

A worn or damaged blade can break, and a piece of the blade could be thrown toward you or bystanders, resulting in serious personal injury or death. Trying to repair a damaged blade may result in discontinued safety certification of the product.

- Inspect the blades periodically for wear or damage.
- Use care when checking the blades. Wrap the blades or wear gloves, and use caution when servicing the blades. Only replace or sharpen the blades; never straighten or weld them.
- On multi-bladed machines, take care as rotating 1 blade can cause other blades to rotate.

Before Inspecting or Servicing the Blades

1. Park the machine on a level surface, disengage the blade-control switch (PTO), and engage the parking brake.
2. Turn the ignition key to the OFF position.
3. Remove the key.

Inspecting the Blades

Service Interval: Before each use or daily

1. Lift the mower deck and secure it in the raised position. Refer to [Raising the Mower Deck into the Service Position \(page 17\)](#).
2. Inspect the cutting edges ([Figure 61](#)).
3. If the edges are not sharp or have nicks, remove and sharpen the blades; refer to [Sharpening the Blades \(page 54\)](#).

4. Inspect the blades, especially the curved area ([Figure 61](#)).
5. If you notice any damage, wear, or a slot forming in this area ([Figure 61](#)), immediately install a new blade.

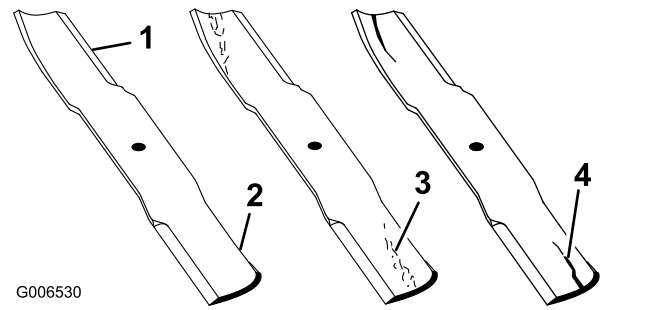

Figure 61

1. Cutting edge
2. Curved area
3. Wear/slot forming
4. Crack

6. Lower the mower deck into operating position; refer to [Lowering the Mower Deck to the Operating Position \(page 18\)](#).

Checking for Bent Blades

1. Move the speed-control lever to the NEUTRAL position to stop the machine.
2. Disengage the PTO, engage the parking brake, shut off the engine, and wait for all moving parts to stop.
3. Rotate 1 blade as shown in [Figure 62](#).
4. Measure from a level surface to the cutting edge at position A of the blade ([Figure 62](#)). Note this dimension.

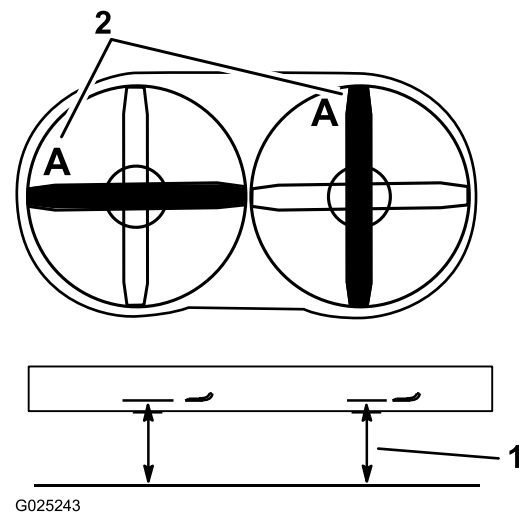

Figure 62

1. Measure here from blade to hard surface.
2. Position A

5. Rotate the opposite end of the blade to position **A**.
6. Measure from a level surface to the cutting edge of the blade at the same position as in step 3 above.

Note: The difference between the dimensions obtained in steps 3 and 6 must not exceed 1/8 inch (3 mm). If this dimension exceeds 1/8 inch (3 mm), the blade is bent and must be replaced; refer to [Removing the Blades](#) (page 54) and [Sharpening the Blades](#) (page 54).

7. Repeat the previous steps for the opposite blade.

⚠ WARNING

A blade that is bent or damaged could break apart and could seriously injure or kill you or bystanders.

- Always replace bent or damaged blade with a new blade.
- Never file or create sharp notches in the edges or surfaces of blade.

Removing the Blades

Note: Make note of the red-colored blade position. From the normal user position, it is located on the right side.

Replace a blades if it hits a solid object, is out of balance, or is bent. To ensure optimum performance and continued safety conformance of the machine, use genuine Toro replacement blades. Replacement blades made by other manufacturers may result in non-conformance with safety standards.

1. Lift the mower deck and secure in the raised position. Refer to [Raising the Mower Deck into the Service Position](#) (page 17).
2. Hold the blade end using a rag or thickly padded glove.
3. Remove the blade, washer, and blade bolt that secures the blade and blade driver ([Figure 63](#)).

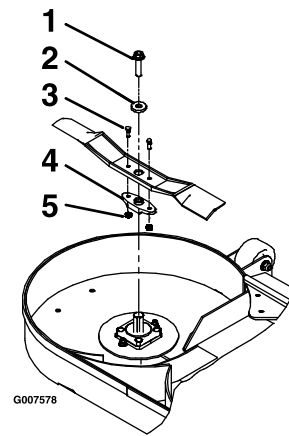

Figure 63

- | | |
|----------------|-----------------|
| 1. Blade bolt | 4. Blade driver |
| 2. Washer | 5. Locknuts |
| 3. Shear bolts | |

4. Remove the blade driver from the existing blade ([Figure 63](#)).

Sharpening the Blades

1. Use a file to sharpen the cutting edge at both ends of the blade ([Figure 64](#)).

Note: Maintain the original angle.

Note: The blade retains its balance if the same amount of material is removed from both cutting edges.

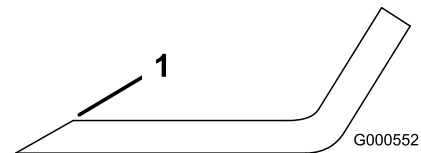

Figure 64

1. Sharpen at original angle.

2. Check the balance of the blade by putting it on a blade balancer ([Figure 65](#)).

Note: If the blade stays in a horizontal position, the blade is balanced and can be used.

Note: If the blade is not balanced, file some metal off the end of the sail area only ([Figure 64](#)).

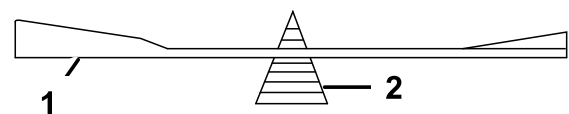

Figure 65

- | | |
|----------|-------------|
| 1. Blade | 2. Balancer |
|----------|-------------|

3. Repeat this procedure until the blade is balanced.

Installing the Blades

Note: Determine the left and right sides of the machine from the normal operating position.

Note: Ensure that you install the red-colored blade on the right side.

1. Install the blade driver to the new blades with the shear bolts and locknuts (Figure 63).
2. Torque the shear bolts to 922 to 1130 N·m (80 to 100 in-lb).

Note: Align the blade-driver flats with the flats on the shaft when installing the blade on the mower deck.

3. Install the blade, washer, and blade bolt to the spindle shaft (Figure 63).
4. Torque the blade bolt to 115 to 149 N·m (85 to 110 ft-lb).
5. Lower the mower deck to the operating position. Refer to [Lowering the Mower Deck to the Operating Position \(page 18\)](#).

▲ WARNING

Operating a mower deck with loose or weakened blade bolts can be dangerous. A loose or weakened blade bolt could allow a blade rotating at a high speed to come out from under the mower deck, causing serious injury or property damage.

- **Replace the blade bolt after striking a foreign object.**
- **Use only genuine Toro replacement parts.**
- **Do not lubricate the threads of the bolt or spindle before assembly.**

Removing the Mower Deck

⚠ WARNING

Operating this machine without an approved Toro front-mount attachment increases the possibility of operator entanglement in drive wheels or forward tip over. Entanglement or tip-over could cause serious injury or death.

When operating this machine without an approved Toro front-mount attachment, do the following:

- Keep feet and clothing away from tires.
- Limit operation to minimum required to install a different front-mount attachment.
- Minimize speed and use extreme caution.
- Only operate on a flat level surface.
- Do not operate up or down a trailer ramp.
- Avoid sudden acceleration or deceleration.

Important: Do not transport this machine without an approved Toro front mount attachment.

1. Shut off the engine, wait for all moving parts to stop, and remove the key. Engage the parking brake.
2. Raise the mower deck up and latch it with the deck-locking pins. Refer to [Raising the Mower Deck into the Service Position](#) (page 17).
3. Remove the hairpin cotters and washers at the top of the deck-lift-assist spring on each side of the machine ([Figure 66](#)).

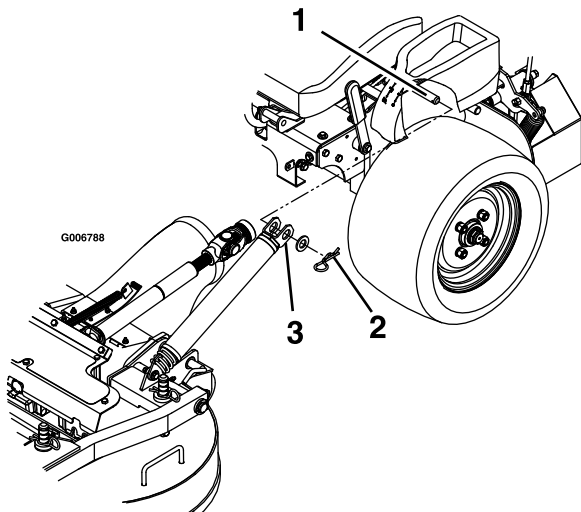

Figure 66

G006788

1. Spring-anchor pin under console
2. Secure springs with a washer and hairpin cotter.
3. Slide spring onto spring-anchor pin.

4. Remove the spring from the spring anchor. Repeat for other side of the machine.
5. Unlatch the mower deck from the raised position and slowly lower the mower deck to ground; refer to [Lowering the Mower Deck to the Operating Position](#) (page 18).

Note: The mower deck becomes heavier once you remove the springs from the anchors. Lower the mower deck carefully.

6. Remove the lynch pins at front of push arms on both sides of the machine ([Figure 67](#)).

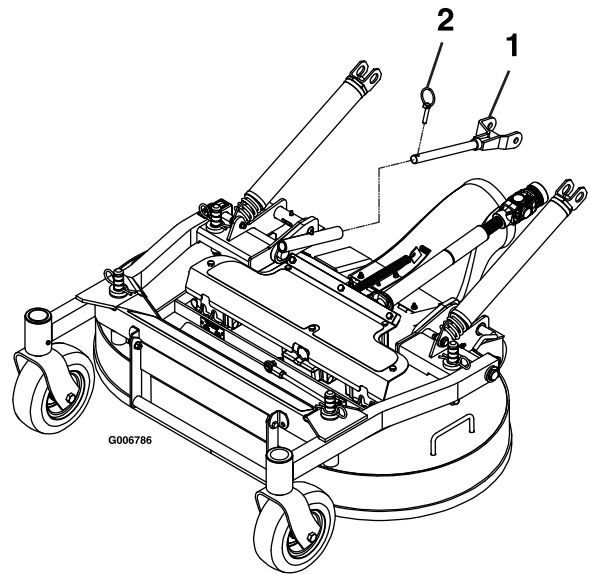

Figure 67

G006786

1. Slide the push arm into the deck push-arm tube.
2. Secure the push pin arm with lynch pin.

7. Remove the hairpin cotter and clevis pin from both sides of the PTO guard ([Figure 68](#)).

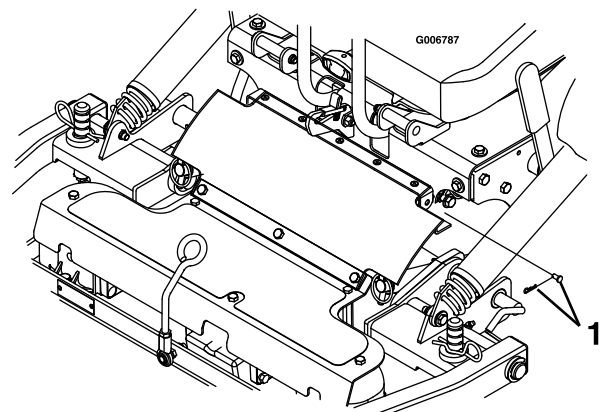

Figure 68

G006787

1. Secure the PTO guard with the clevis pin and hairpin cotter.

8. Raise the seat and disconnect the drive shaft using the quick coupler at the jackshaft ([Figure 69](#)).

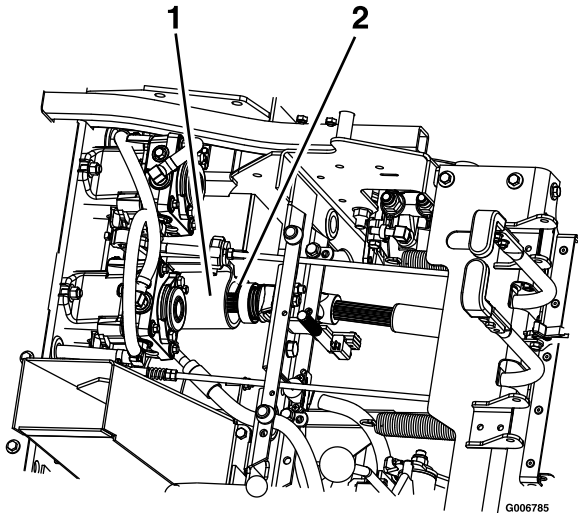

Figure 69

1. Jackshaft
2. Drive shaft

9. Pull the mower deck forward to remove it from the machine.

Installing the Mower Deck

Important: Do not transport the machine without an approved Toro front mount attachment.

1. Shut off the engine, wait for all moving parts to stop and remove the key. Engage the parking brake.
2. Roll the mower deck up to the machine with the discharge tube down, making sure that the deck springs are located above the drive wheel and below the console on each side.
3. Raise the seat and install the drive shaft onto the jackshaft ([Figure 69](#))
4. Align the mower-deck push-arm tubes to the machine push-arms and push the mower deck rearward.
5. Secure the push arms with the lynch pins on the left and right sides of the machine ([Figure 67](#)).
6. Align the upper portion of the rubber PTO guard to the tabs on the front of the console and secure with a clevis pin and hairpin cotter on each side ([Figure 68](#)).
7. Release the mower-deck locking pins on each side, raise the mower deck to the service position, and secure the deck latch onto hook. Refer to [Raising the Mower Deck into the Service Position](#) (page 17).

8. Install the springs onto the spring anchor pins under the left and right consoles and secure with a washer and hairpin cotter ([Figure 66](#)).
9. Unlatch the mower deck from the raised position, slowly lower the mower deck to ground, and lock the deck-locking pins on each side. Refer to [Lowering the Mower Deck to the Operating Position](#) (page 18).

Adjusting the Locking-Pin Stop on the Mower Deck

1. Slide the mower-deck locking pins in on both sides and rotate to lock the deck in the operation position.
2. Loosen the jam nut and turn the stop screw clockwise until the locking pin is tight and cannot be rotated by hand ([Figure 70](#)).

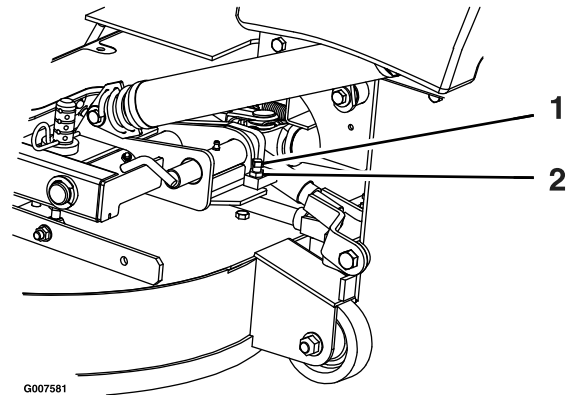

Figure 70

1. Rotate the stop screw clockwise until locking pin is tight, then back off 1/2 turn.
2. Loosen the jam nut
3. Loosen the stop screw counter clockwise 1/2 turn and tighten the jam nut.
4. Test the locking pin to make sure it slides freely. Adjust it if necessary.

Cleaning

Cleaning under the Mower

Service Interval: Before each use or daily

1. Move the speed-control lever to the NEUTRAL position to stop the machine.
2. Disengage the PTO, engage the parking brake, shut off the engine, and wait for all moving parts to stop.
3. Lift the mower deck and secure it in the raised position. Refer to [Raising the Mower Deck into the Service Position \(page 17\)](#).
4. Clean any grass buildup under the mower deck.
5. Lower the mower deck to the operating position. Refer to [Lowering the Mower Deck to the Operating Position \(page 18\)](#).

Cleaning Debris from the Machine

Service Interval: Before each use or daily

1. Shut off the engine, wait for all moving parts to stop, and remove the key. Engage the parking brake.
2. Clean off any oil, debris, or grass buildup on the machine, especially around the fuel tank, engine, and exhaust area.

Disposing of Waste

Engine oil, batteries, hydraulic fluid, and engine coolant are pollutants to the environment. Dispose of these according to your state and local regulations.

Storage

Cleaning and Storage

1. Disengage the power takeoff (PTO), engage the parking brake, shut off the engine, and remove the key.
2. Remove grass clippings, dirt, and grime from the external parts of the entire machine, especially the engine and hydraulic system. Clean dirt and chaff from the outside the engine cylinder head fins and blower housing.

Important: You can wash the machine with mild detergent and water. Do not pressure wash the machine. Avoid excessive use of water, especially near the control panel, engine, hydraulic pumps, and motors.

3. Check the brake; refer to [Adjusting the Parking Brake \(page 43\)](#).
4. Service the air cleaner; refer to [Servicing the Air Cleaner \(page 33\)](#).
5. Grease the machine; refer to [Lubrication \(page 30\)](#).
6. Change the crankcase oil; refer to [Changing the Engine Oil \(page 35\)](#).
7. Check the tire pressure; refer to [Checking the Tire Pressure \(page 41\)](#).
8. Change the hydraulic filters; refer to [Replacing the Hydraulic Filter \(page 52\)](#).
9. Charge the battery; refer to [Charging the Battery \(page 39\)](#).
10. Scrape any heavy buildup of grass and dirt from the underside of the mower, then wash the mower with a garden hose.

Note: Run the machine with the blade-control switch (PTO) engaged and the engine at high idle for 2 to 5 minutes after washing.

11. Check the condition of the blades; refer to [Inspecting the Blades \(page 53\)](#).
12. For storage over 30 days, prepare the machine as follows:
 - A. Add a petroleum-based stabilizer/conditioner to fuel in the tank. Follow the mixing instructions from the stabilizer manufacturer. Do not use an alcohol-based stabilizer (ethanol or methanol).

Note: A fuel stabilizer/conditioner is most effective when mixed with fresh fuel and used at all times.
 - B. Run the engine to distribute conditioned fuel through the fuel system (5 minutes).

- C. Shut off the engine, wait for it to cool, and drain the fuel tank; refer to [Servicing the Fuel Tank \(page 38\)](#).
- D. Start the engine and run it until it stops.
- E. Dispose of fuel properly. Recycle as per local codes.

***Important:* Do not store fuel with stabilizer/conditioner over 90 days.**

- 13. Check and tighten all bolts, nuts, and screws. Repair or replace any part that is damaged.
- 14. Paint all scratched or bare metal surfaces. Paint is available from your Authorized Service Dealer.
- 15. Store the machine in a clean, dry garage or storage area.
- 16. Remove the key from the ignition switch and keep it out of reach of children or other unauthorized users.
- 17. Cover the machine to protect it and keep it clean.

Troubleshooting

| Problem | Possible Cause | Corrective Action |
|---|---|--|
| The starter does not crank. | <ol style="list-style-type: none"> 1. The blade-control switch (PTO) is engaged. 2. The parking brake is not engaged. 3. The motion-control levers are not in the NEUTRAL-LOCK position. 4. The operator is not seated. 5. The battery is dead. 6. The electrical connections are corroded or loose. 7. The fuse is blown. 8. The relay or switch is worn or damaged. | <ol style="list-style-type: none"> 1. Move the blade-control switch (PTO) to the disengaged position. 2. Engage the parking brake. 3. Ensure that the motion-control levers are in the NEUTRAL-LOCK position. 4. Sit on the seat. 5. Charge the battery. 6. Check the electrical connections for good contact. 7. Replace the fuse. 8. Contact an Authorized Service Dealer. |
| The engine does not start, starts hard, or fails to keep running. | <ol style="list-style-type: none"> 1. The fuel tank is empty. 2. The fuel-shutoff valve is closed. 3. The oil level in the crankcase is low. 4. The throttle is not in the correct position. 5. There is dirt in the fuel filter. 6. There is dirt, water, or stale fuel in the fuel system. 7. The air cleaner is dirty. 8. The seat switch is not functioning properly. 9. The electrical connections are corroded, loose, or damaged. 10. The relay or switch is worn or damaged. 11. The spark plug is fouled or improperly gapped. 12. The spark-plug wire is not connected. | <ol style="list-style-type: none"> 1. Fill the fuel tank. 2. Open the fuel-shutoff valve. 3. Add oil to the crankcase. 4. Be sure that the throttle control is midway between the slow and fast positions. 5. Replace the fuel filter. 6. Contact an Authorized Service Dealer. 7. Clean or replace the air-cleaner element. 8. Check the seat-switch indicator. Replace the seat if necessary. 9. Check the electrical connections for good contact. Clean the connector terminals thoroughly with electrical-contact cleaner, apply dielectric grease, and make the appropriate connections. 10. Contact an Authorized Service Dealer. 11. Adjust or replace the spark plug. 12. Check the spark-plug wire connection. |
| The engine loses power. | <ol style="list-style-type: none"> 1. The engine load is excessive. 2. The air cleaner is dirty. 3. The oil level in the crankcase is low. 4. The cooling fins and the air passages above the engine are plugged. 5. The vent hole in the fuel cap is plugged. 6. There is dirt in the fuel filter. 7. There is dirt, water, or stale fuel in the fuel system. | <ol style="list-style-type: none"> 1. Reduce the ground speed. 2. Clean the air-cleaner element. 3. Add oil to the crankcase. 4. Remove the obstruction from the cooling fins and the air passages. 5. Clean or replace the fuel cap. 6. Replace the fuel filter. 7. Contact an Authorized Service Dealer. |
| The engine overheats. | <ol style="list-style-type: none"> 1. The engine load is excessive. 2. The oil level in the crankcase is low. 3. The cooling fins and the air passages above the engine are plugged. | <ol style="list-style-type: none"> 1. Reduce the ground speed. 2. Add oil to the crankcase. 3. Remove the obstruction from the cooling fins and the air passages. |

| Problem | Possible Cause | Corrective Action |
|--|---|---|
| The mower pulls left or right (with levers fully forward). | <ol style="list-style-type: none"> 1. The tracking needs adjustment. 2. The tire pressure in drive tires not correct. 3. The reverse indicator and speed-control linkage need adjustment. | <ol style="list-style-type: none"> 1. Adjust the tracking. 2. Adjust tire pressure in the drive tires. 3. Adjust the reverse indicator and the speed-control linkage. |
| The machine does not drive. | <ol style="list-style-type: none"> 1. The bypass valves are not closed tight. 2. The pump belt is worn, loose or broken. 3. The pump belt is off a pulley. 4. The idler spring is broken or missing. 5. The hydraulic fluid level is low or too hot. | <ol style="list-style-type: none"> 1. Tighten the bypass valves. 2. Change the belt. 3. Change the belt. 4. Replace the spring. 5. Add hydraulic fluid to reservoirs or let it cool down. |
| The machine vibrates abnormally. | <ol style="list-style-type: none"> 1. The cutting blade(s) is/are bent or unbalanced. 2. The blade mounting bolt is loose. 3. The engine mounting bolts are loose. 4. There is a loose engine pulley, idler pulley, or blade pulley. 5. The engine pulley is damaged. 6. The blade spindle is bent. 7. The belt is damaged. | <ol style="list-style-type: none"> 1. Install new cutting blade(s). 2. Tighten the blade mounting bolt. 3. Tighten the engine mounting bolts. 4. Tighten the appropriate pulley. 5. Contact an Authorized Service Dealer. 6. Contact an Authorized Service Dealer. 7. Install new belt. |
| The machine produces an uneven cutting height. | <ol style="list-style-type: none"> 1. The blade(s) is/are not sharp. 2. The cutting blade(s) is/are bent. 3. The mower deck is not level. 4. The underside of mower is dirty. 5. The tire pressure in drive tires not correct. 6. The spacers are in the wrong location. 7. The tips of adjacent blades are at an uneven cutting height. Blades tips should be even within 3/16 inch which is approximately one blade thickness. | <ol style="list-style-type: none"> 1. Sharpen the blade(s). 2. Install new cutting blade(s). 3. Level the mower deck from side-to-side and front-to-rear. 4. Clean the underside of the mower. 5. Adjust the tire pressure in the drive tires. 6. Position the spacers under hairpin cotters. 7. Replace blades, spindles and (or) check for damage to mower deck. |
| The blades do not rotate. | <ol style="list-style-type: none"> 1. The PTO belt is worn, loose, or broken. 2. The PTO shaft is not connected. 3. The PTO belt is off the pulley. | <ol style="list-style-type: none"> 1. Check the belt tension or replace belt 2. Connect the PTO shaft. 3. Check the belt for damage. Install the belt and check adjusting shafts and belt guides for correct position. |

Schematics

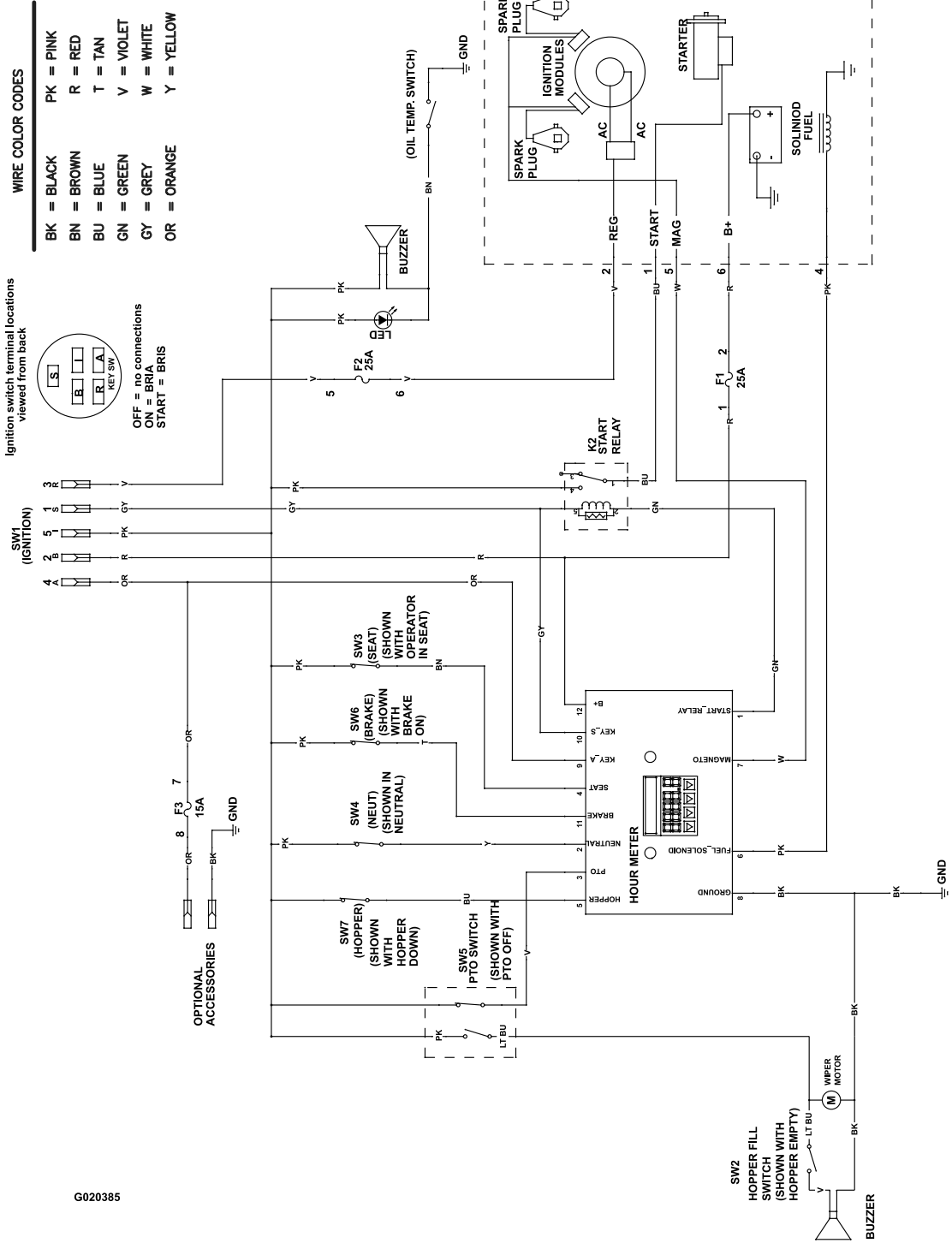

G020385

Wire Diagram (Rev. A)

g020385

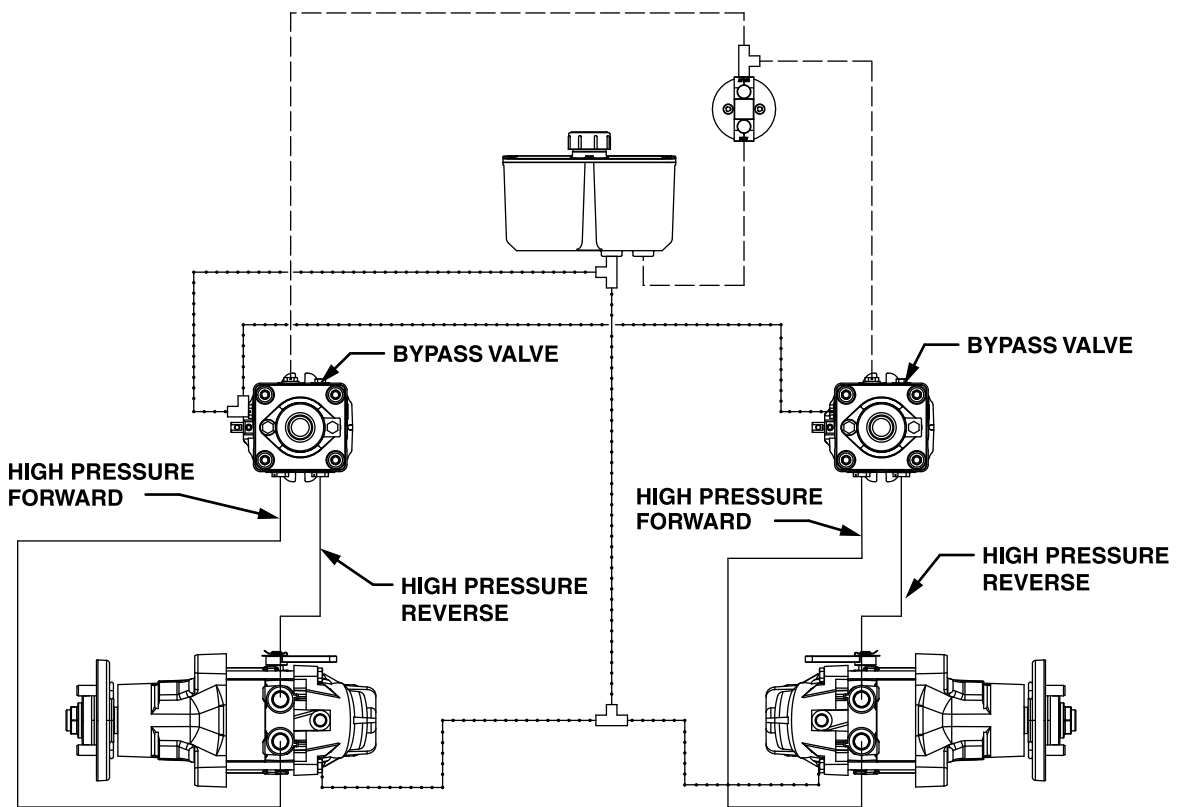

G020536

- HIGH PRESSURE
- - - - CHARGE PUMP
- · - · - CASE DRAIN

Hydraulic Diagram (Rev. A)

g020536



The Toro Warranty

A Limited Warranty (see warranty periods below)

Landscape Contractor Equipment (LCE)
Riding Product

Conditions and Products Covered

The Toro Company and its affiliate, Toro Warranty Company, pursuant to an agreement between them, jointly promise to repair the Toro Products listed below if defective in materials or workmanship.

The following time periods apply from the original date of purchase:

| Products | Warranty Period |
|------------------------------|--|
| GrandStand® Mowers | 5 years or 1,200 hours ² |
| • Engines ³ | 3 years |
| Z Master® 3000 Series Mowers | 5 years or 1,250 hours ² |
| • Engines ³ | 3 years |
| Z Master® 5000 Series Mowers | 5 years or 1,250 hours ² |
| • Engines ³ | 3 years |
| Z Master® 6000 Series Mowers | 5 years or 1,250 hours ² |
| • Engines ³ | 3 years |
| Z Master®7000 Series Mowers | 4 years or 1,200 hours ² |
| • Engines ³ | 2 years |
| Z Master®8000 Series Mowers | 2 years |
| • Engines ³ | 3 years |
| TITAN HD 1500 Series | 4 years or 500 Hours ² |
| • Engines | Toro – 4 years or 500 hours |
| TITAN HD 2000 Series | 4 years or 750 Hours ² |
| • Engines ³ | Kohler – 3 years |
| TITAN HD 2500 Series | 4 years or 1000 Hours ² |
| • Engines ³ | Kawasaki – 3 years |
| All Mowers | |
| • Battery | 90 days Parts and Labor 1 year Parts only |
| • Belts and Tires | 90 days |
| • Attachments | 1 year |

¹Residential use means use of the product on the same lot as your home. Use at more than one location is considered commercial use and the commercial warranty would apply.

²Whichever occurs first.

³Some engines used on Toro Products are warranted by the engine manufacturer.

Owner Responsibilities

You must maintain your Toro Product by following the maintenance procedures described in the *Operator's Manual*. Such routine maintenance, whether performed by a dealer or by you, is at your expense.

Instructions for Obtaining Warranty Service

If you think that your Toro Product contains a defect in materials or workmanship, follow this procedure:

- Contact any Authorized Toro Service Dealer to arrange service at their dealership. To locate a dealer convenient to you, access our web site at www.Toro.com. You may also call the numbers listed in item #3 to use the 24-hour Toro Dealer locator system.
- Bring the product and your proof of purchase (sales receipt) to the Service Dealer. The dealer will diagnose the problem and determine if it is covered under warranty.

Countries Other than the United States or Canada

Customers who have purchased Toro products outside the United States or Canada should contact their Toro Distributor (Dealer) to obtain guarantee policies for your country, province, or state. If for any reason you are dissatisfied with your Distributor's service or have difficulty obtaining guarantee information, contact the Toro importer. If all other remedies fail, you may contact us at Toro Warranty Company.

Australian Consumer Law: Australian customers will find details relating to the Australian Consumer Law either inside the box or at your local Toro Dealer.

- If for any reason you are dissatisfied with the Service Dealer's analysis or with the assistance provided, contact us at:

Toro Warranty Company
Customer Care Department, RLC Division
8111 Lyndale Avenue South
Bloomington, MN 55420-1196
888-865-5676 (U.S. Customers)
888-865-5691 (Canada customers)

Items and Conditions Not Covered

There is no other express warranty except for special emission system coverage and engine warranty coverage on some products. This express warranty does not cover the following:

- Cost of regular maintenance service or parts, such as filters, fuel, lubricants, oil changes, spark plugs, air filters, blade sharpening or worn blades, cable/linkage adjustments, or brake and clutch adjustments
- Components failing due to normal wear
- Any product or part which has been altered, misused, neglected, or requires replacement or repair due to accidents or lack of proper maintenance
- Pickup and delivery charges
- Repairs or attempted repairs by anyone other than an Authorized Toro Service Dealer
- Repairs necessary due to failure to follow recommended fuel procedure (consult *Operator's Manual* for more details)
 - Removing contaminants from the fuel system is not covered
 - Use of old fuel (more than one month old) or fuel which contains more than 10% ethanol or more than 15% MTBE
 - Failure to drain the fuel system prior to any period of non-use over one month

General Conditions

All repairs covered by these warranties must be performed by an Authorized Toro Service Dealer using Toro approved replacement parts.

Neither The Toro Company nor Toro Warranty Company is liable for indirect, incidental or consequential damages in connection with the use of the Toro Products covered by this warranty, including any cost or expense of providing substitute equipment or service during reasonable periods of malfunction or non-use pending completion of repairs under this warranty.

All implied warranties of merchantability (that the product is fit for ordinary use) and fitness for use (that the product is fit for a particular purpose) are limited to the duration of the express warranty.

Some states do not allow exclusions of incidental or consequential damages, or limitations on how long an implied warranty lasts, so the above exclusions and limitations may not apply to you.

This warranty gives you specific legal rights, and you may also have other rights which vary from state to state.