



HoverPro® 400 Machine

Model No. 02615—Serial No. 40000000 and Up

Operator's Manual

Introduction

WARNING

CALIFORNIA

Proposition 65 Warning

This product contains a chemical or chemicals known to the State of California to cause cancer, birth defects, or reproductive harm.

The engine exhaust from this product contains chemicals known to the State of California to cause cancer, birth defects, or other reproductive harm.

It is a violation of California Public Resource Code Section 4442 or 4443 to use or operate the engine on any forest-covered, brush-covered, or grass-covered land unless the engine is equipped with a spark arrester, as defined in Section 4442, maintained in effective working order or the engine is constructed, equipped, and maintained for the prevention of fire. **This machine does not come equipped with a spark arrester standard. You must install the spark arrester kit before operating this machine in California.**

This spark ignition system complies with Canadian ICES-002.

The enclosed *Engine Owner's Manual* is supplied for information regarding the US Environmental Protection Agency (EPA) and the California Emission Control Regulation of emission systems, maintenance, and warranty. Replacements may be ordered through the engine manufacturer.

Read this information carefully to learn how to operate and maintain your product properly and to avoid injury and product damage. You are responsible for operating the product properly and safely. Keep for future reference.

You may contact Toro directly at www.Toro.com for product and accessory information, help finding a dealer, or to register your product.

Whenever you need service, genuine Toro parts, or additional information, contact an Authorized Service

Dealer or Toro Customer Service and have the model and serial numbers of your product ready. [Figure 1](#) identifies the location of the model and serial numbers on the product.

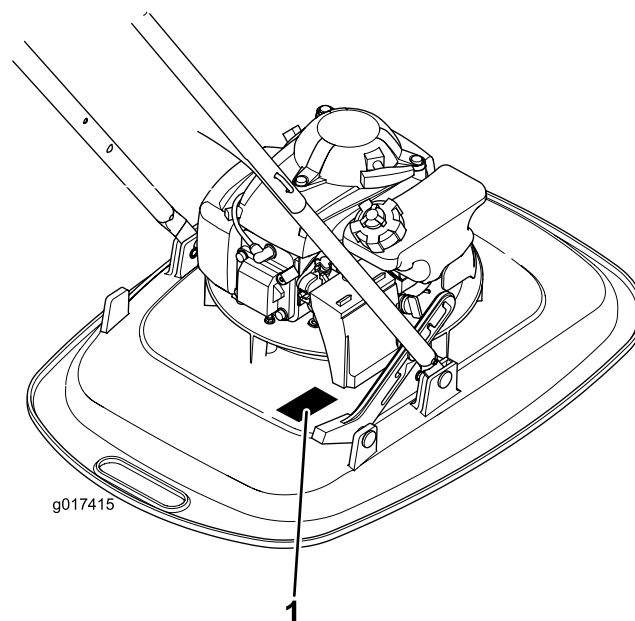

Figure 1

1. Model and serial number plate

Write the product model and serial numbers in the space below:

Model No.	_____
Serial No.	_____

This manual identifies potential hazards and has safety messages identified by the safety-alert symbol ([Figure 2](#)), which signals a hazard that may cause serious injury or death if you do not follow the recommended precautions.



Figure 2

1. Safety-alert symbol



This manual uses 2 words to highlight information. **Important** calls attention to special mechanical information and **Note** emphasizes general information worthy of special attention.

For models with stated engine horsepower, the gross horsepower of the engine was laboratory rated by the engine manufacturer in accordance with SAE J1349. As configured to meet safety, emission, and operating requirements, the actual engine horsepower on this class machine will be significantly lower.

Contents

- Introduction 1
- Safety 2
 - General Safety 2
 - Before Operation Safety 3
 - During Operating Safety 3
 - After Operating Safety 4
 - Maintenance Safety 4
 - Safety and Instructional Decals 5
- Setup 7
 - 1 Assembling the Handle 7
 - 2 Filling the Engine with Oil 7
- Product Overview 8
 - Specifications 9
- Operation 9
 - Filling the Fuel Tank 9
 - Checking the Engine Oil Level 10
 - Adjusting the Cutting Height 10
 - Starting the Engine 11
 - Adjusting the Handle Position 12
 - Shutting Off the Engine 12
 - Operating Tips 13
- Maintenance 14
 - Recommended Maintenance Schedule(s) 14
 - Preparing for Maintenance 14
 - Replacing the Air Cleaner 15
 - Changing the Engine Oil 15
 - Servicing the Spark Plug 16
 - Replacing the Nylon Cutting String 16
 - Cleaning the Machine 16
- Storage 17
 - Preparing the Machine for Storage 17
- Troubleshooting 18

Safety

The following safety section is adapted from ANSI B71.4–2012 and EN 14910.

General Safety

This product is capable of injuring hands and feet and of throwing objects. Always follow all safety instructions to avoid serious personal injury.

Using this product for purposes other than its intended use could prove dangerous to you and bystanders.

- Read and understand the contents of this *Operator's Manual* before starting the engine.
- Do not put your hands or feet near moving components of the machine.
- Do not operate the machine without all guards and other safety protective devices in place and working on the machine.
- Keep clear of any discharge opening. Keep bystanders a safe distance away from the machine.
- Keep children out of the operating area. Never allow children to operate the machine.
- Stop the machine and shut off the engine before servicing, fueling, or unclogging the machine.

Improperly using or maintaining this machine can result in injury. To reduce the potential for injury, comply with these safety instructions and always pay attention to the safety-alert symbol, which means Caution, Warning, or Danger—personal safety instruction. Failure to comply with these instructions may result in personal injury or death.

You can find additional items of safety information in their respective sections throughout this manual.

Before Operation Safety

General Safety

- Become familiar with the safe operation of the equipment, operator controls, and safety signs.
- Check that all guards and safety devices are in place and working properly.
- Always inspect the machine to ensure that the cutting unit bolt, line, and disc are not worn or damaged.
- Inspect the area where you will use the machine and remove all objects that the machine could throw.
- Adjusting the cutting height may bring you into contact with the moving cutting disc, causing injury.
 - Shut off the engine and wait for all moving parts to stop.
 - Disconnect the spark-plug wire from the spark plug before adjusting the cutting height.

Fuel Safety

▲ DANGER

Fuel is extremely flammable and highly explosive. A fire or explosion from fuel can burn you and others and can damage property.

- **To prevent a static charge from igniting the fuel, place the container and/or machine directly on the ground before filling, not in a vehicle or on an object.**
- **Fill the fuel tank outdoors, in an open area, when the engine is cold. Wipe up any fuel that spills.**
- **Do not handle fuel when smoking or around an open flame or sparks.**
- **Store fuel in an approved container and keep it out of the reach of children.**

▲ WARNING

Fuel is harmful or fatal if swallowed. Long-term exposure to vapors can cause serious injury and illness.

- **Avoid prolonged breathing of vapors.**
- **Keep your hands and face away from the nozzle and the fuel-tank opening.**
- **Keep fuel away from your eyes and skin.**

During Operating Safety

General Safety

- Wear appropriate clothing, including eye protection; slip-resistant, substantial footwear; and hearing protection. Tie back long hair, and do not wear jewelry.
- Do not operate the machine while ill, tired, or under the influence of alcohol or drugs.
- The cutting unit is sharp; contacting the disc or line can result in serious personal injury. Shut off the engine and wait for all moving parts to stop before leaving the operating position.
- When you release the operator-presence control, the engine should shut off and the cutting unit should stop within 3 seconds. If not, stop using your machine immediately and contact an Authorized Service Dealer.
- Operate the machine only in good visibility and appropriate weather conditions. Do not operate the machine when there is the risk of lighting.
- Wet grass or leaves can cause serious injury if you slip and contact the cutting unit. Mow only in dry conditions, if possible.
- Use extreme care when approaching blind corners, shrubs, trees, or other objects that may block your view.
- Watch for holes, ruts, bumps, rocks, or other hidden objects. Uneven terrain could cause a slip-and-fall accident.
- Stop the machine and inspect the cutting unit after striking an object or if there is an abnormal vibration in the machine. Make all necessary repairs before resuming operation.
- Before leaving the operating position, shut off the engine and wait for all moving parts to stop.
- If the engine has been running the muffler will be hot and can severely burn you. Keep away from the hot muffler.
- Use accessories and attachments approved by The Toro® Company only.

Slope Safety

⚠ WARNING

Running the engine on slopes of more than 25 degrees will cause severe engine damage due to a lack of lubrication. Some of the potential damage could include stuck valves, scored pistons, or burned crank bearings.

- **Before operating on any slope, a site survey should be completed to determine the actual slope where the unit will be operating.**
- **Do not run the 4 cycle Honda engine in this product on slopes of more than 25 degrees.**
- Avoid mowing wet grass. Poor footing could cause a slip-and-fall accident.
- Mow with caution near drop-offs, ditches, or embankments.
- When using the machine, always keep both hands on the handlebar.
- When cutting from the top of a steep slope and you need longer reach, never tie the machine to a rope; use an approved extended handlebar.

After Operating Safety

General Safety

- Clean grass and debris from the machine to help prevent fires. Clean up oil or fuel spills.
- Allow the engine to cool before storing the machine in any enclosure.
- Never store the machine or fuel container where there is an open flame, spark, or pilot light, such as on a water heater or on other appliances.

Hauling Safety

- Use care when loading or unloading the machine.
- Secure the machine.
- The engine is not to be used to lift the machine, as sharp edges could cause injury.

Maintenance Safety

- Disconnect the spark-plug wire from the spark plug before performing any maintenance procedure.
- Wear gloves and eye protection when servicing the machine.
- Wear gloves when servicing the cutting unit.
- Never tamper with safety devices. Check their proper operation regularly.
- Tipping the machine may cause the fuel to leak. Fuel is flammable and explosive, and can cause personal injury. Run the engine dry to remove the fuel with a hand pump; never siphon the fuel.

Safety and Instructional Decals

Important: Safety decals and instructions are easily visible to the operator and are located near any area of potential danger. Replace any decal that is damaged or missing.

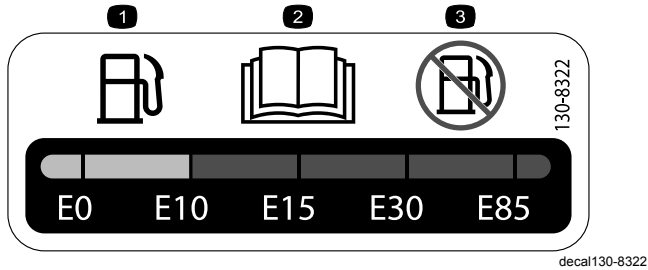

130-8322

1. Use only fuel with an alcohol content by volume under 10%.
2. Read the *Operator's Manual* for more information on fuel.
3. Do not use fuel with an alcohol content by volume greater than 10%.

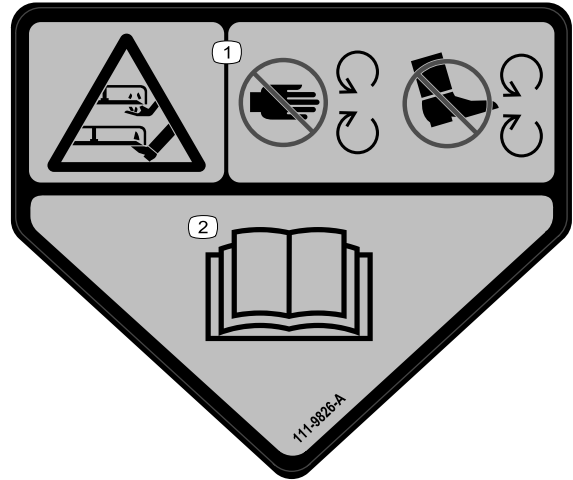

111-9826

1. Cutting/dismemberment hazard of hand or foot, cutting unit—keep your hands and feet away from moving parts.
2. Read the *Operator's Manual*.

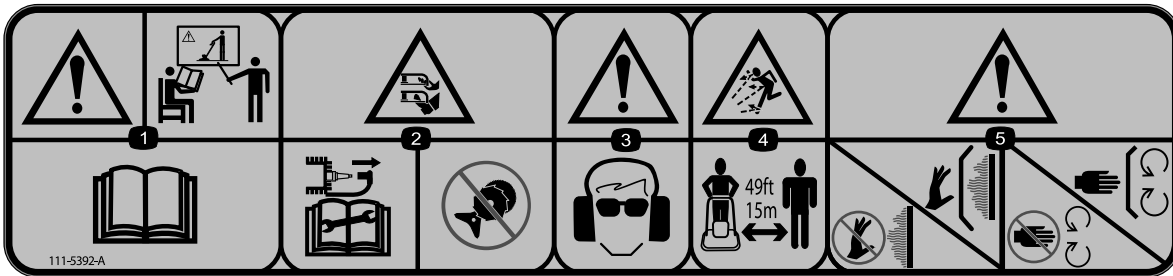

111-5392

1. Warning—Receive training on the product; read the *Operator's Manual*.
2. Cutting/dismemberment hazard of hand or foot, nylon line; disconnect the wire from the spark plug before working on the machine; never fit metal cutting parts.
3. Warning—wear eye and hearing protection.
4. Thrown object hazard; keep bystanders at least 15 m (49 ft) away from the machine.
5. Warning—do not touch hot surfaces; keep guards in place; Stay away from moving parts; keep guards in place.



94-8072

decal94-8072

1. Warning—cutting/dismemberment hazard of hand or foot, cutting mechanism.
-



g017410

H295159

g017410

1. Engine stop (shut off)
-

Setup

Note: Determine right and left side of the machine from normal operating position.

1

Assembling the Handle

No Parts Required

Procedure

1. Slide the lower handle into the frame (Figure 3).

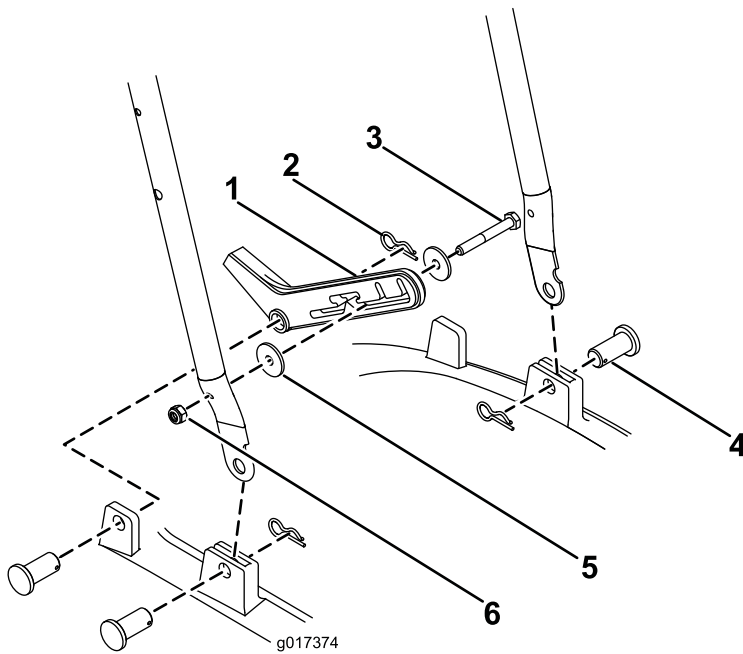

Figure 3

- | | |
|-------------|------------------|
| 1. Footstop | 4. Retaining pin |
| 2. Hairpin | 5. Washer |
| 3. Bolt | 6. Locknut |

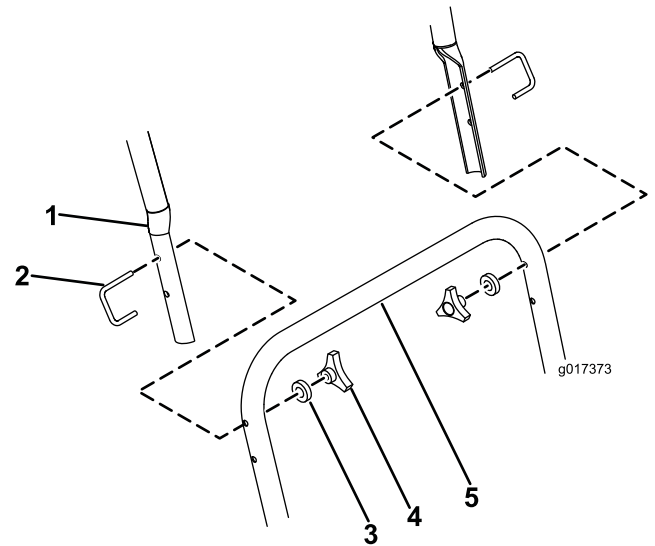

Figure 4

- | | |
|-----------------|-----------------|
| 1. Upper handle | 4. U-bolt |
| 2. Hand wheel | 5. Lower handle |
| 3. Washer | |

2

Filling the Engine with Oil

No Parts Required

Procedure

Important: Your machine does not come with oil in the engine. Before starting the engine, fill the engine with oil.

Max. fill: 0.59 L (20 fl oz), type: Multigrade Mineral 10W-30 oil with an API service classification of SF, SG, SH, SJ, SL, or higher.

1. Move the machine to a level surface.
2. Remove the dipstick (Figure 5).

2. Secure each side with a retaining pin and a hairpin (Figure 3).
3. Secure the footstop to the right side of the lower handle using an M6 nut, and M6 bolt, and 2 washers (Figure 3).
4. Attach the footstop to the frame with a retaining pin and a hairpin (Figure 3).
5. Connect the upper handle to the lower handle by securing each side with a U-bolt, an M6 washer, and a handwheel (Figure 4).

Product Overview

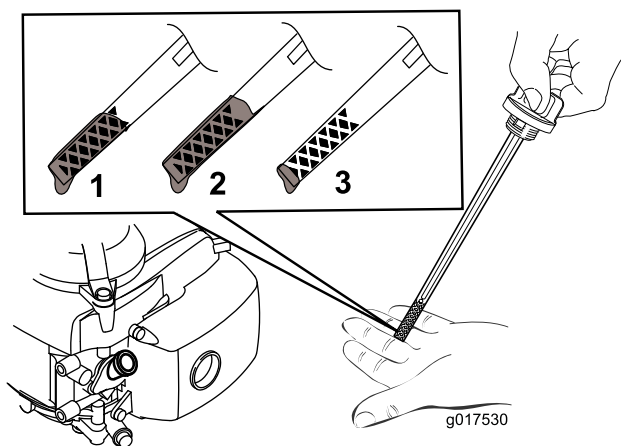

Figure 5

1. The oil level is at its maximum.
2. The oil level is too high—remove oil from the crankcase.
3. The oil level is too low—add oil to the crankcase.

3. **Slowly** pour oil into the oil-fill hole, wait 3 minutes, and check the oil level on the dipstick by wiping the dipstick clean and then inserting, **but not screwing in**, the oil-fill cap into the hole (Figure 6).

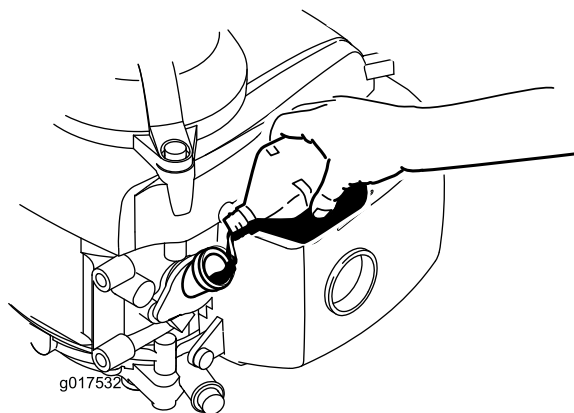

Figure 6

Note: Fill the engine crankcase with oil until the dipstick indicates that the engine oil level is correct as shown in Figure 5. If you overfill the engine with oil, remove the excess oil as directed in [Changing the Engine Oil \(page 15\)](#).

4. Install the dipstick and hand tighten it securely.

Important: Change the engine oil after the first 5 operating hours; change it yearly thereafter. Refer to [Changing the Engine Oil \(page 15\)](#).

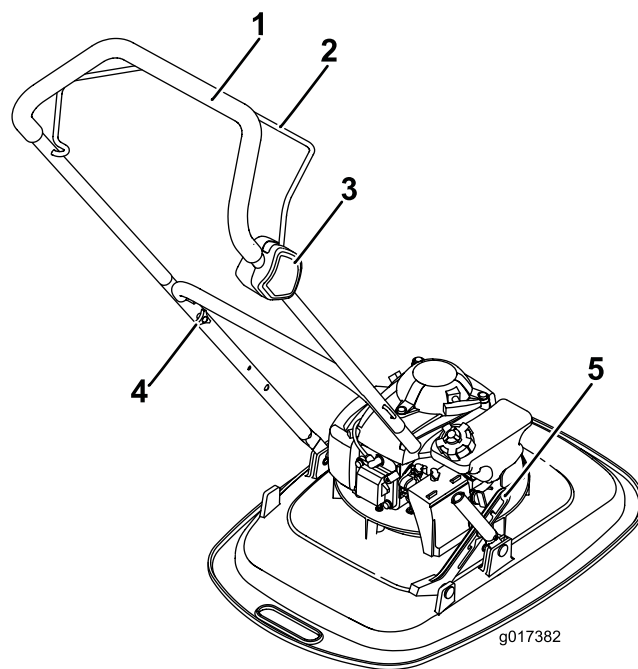

Figure 7

- | | |
|------------------------------|----------------------------|
| 1. Handle | 4. Handlebar securing knob |
| 2. Operator-presence control | 5. Footstop |
| 3. Switch box | |

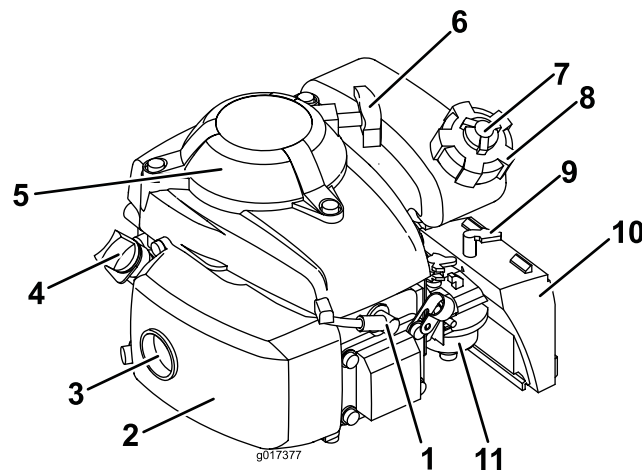

Figure 8

- | | |
|------------------|-----------------------|
| 1. Spark plug | 7. Fuel-cap-vent knob |
| 2. Exhaust guard | 8. Fuel cap |
| 3. Exhaust | 9. Choke lever |
| 4. Dipstick | 10. Air cleaner |
| 5. Finger guard | 11. Carburetor |
| 6. Starter grip | |

Specifications

Model	Cutting width	Product width
02615	400 mm (15-3/4 inches)	500 mm (19-11/16 inches)

Operation

Filling the Fuel Tank

- For best results, use only clean, fresh, unleaded gasoline with an octane rating of 87 or higher ((R+M)/2 rating method).
- Oxygenated fuel with up to 10% ethanol or 15% MTBE by volume is acceptable.
- **Do not** use ethanol blends of gasoline, such as E15 or E85, with more than 10% ethanol by volume. Performance problems and/or engine damage may result, which may not be covered under warranty.
- **Do not** use gasoline containing methanol.
- **Do not** store fuel either in the fuel tank or in fuel containers over the winter unless fuel stabilizer has been added to the fuel.
- **Do not** add oil to gasoline.

Fill the fuel tank with fresh unleaded regular gasoline from a major name-brand service station (Figure 9).

Important: To reduce starting problems, add fuel stabilizer to the fuel all season, mixing it with fuel less than 30 days old.

Refer to your engine owner's manual for additional information.

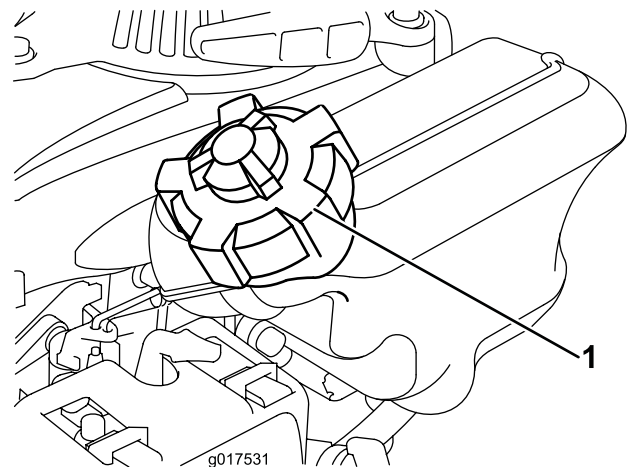

Figure 9

1. Fuel cap

Checking the Engine Oil Level

Service Interval: Before each use or daily

1. Move the machine to a level surface.
2. Remove the dipstick and wipe it with a clean cloth.
3. Insert, **but do not screw in**, the dipstick into the oil-fill hole.
4. Remove the dipstick and check it.
5. To determine the proper oil level on the dipstick, refer to [Figure 10](#)).

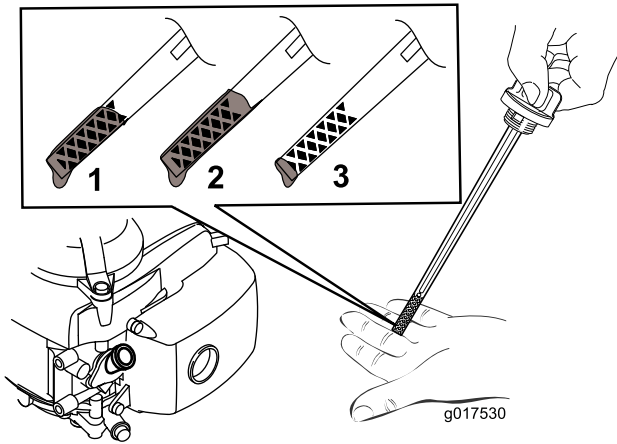

Figure 10

1. The oil level is at its maximum.
 2. The oil level is too high—remove oil from the crankcase.
 3. The oil level is too low—add oil to the crankcase.
-
6. If the oil level is low, **slowly** pour oil into the oil-fill hole, wait 3 minutes, and check the oil level on the dipstick by wiping the dipstick clean and then inserting, **but not screwing in**, the oil-fill cap into the hole.

Note: Max. fill: 0.59 L (20 fl oz), Multigrade Mineral 10W-30 oil with an API service classification of SF, SG, SH, SJ, SL, or higher.

Note: Fill the engine crankcase with oil until the dipstick indicates that the engine oil level is correct as shown in [Figure 10](#). If you overfill the engine with oil, remove the excess oil as directed in [Changing the Engine Oil](#) (page 15).

7. Install the dipstick and hand tighten it securely.

Important: Change the engine oil after the first 5 operating hours; change it yearly thereafter. Refer to [Changing the Engine Oil](#) (page 15).

Adjusting the Cutting Height

⚠ WARNING

Adjusting the cutting height may bring you into contact with the moving cutting unit, causing serious injury.

- Shut off the engine and wait for all moving parts to stop.
- Wear gloves while handling the cutting unit.

⚠ CAUTION

If the engine has been running, the muffler will be hot and can severely burn you. Keep away from the hot muffler.

Adjust the cutting height as desired.

1. Turn the fuel switch to the OFF position.
2. Disconnect the wire from the spark plug.
3. Tilt the machine on its side, with the dipstick down.
4. **Wearing protective gloves**, remove the nylon cutting line.
5. Install the nylon cutting line at the desired height.

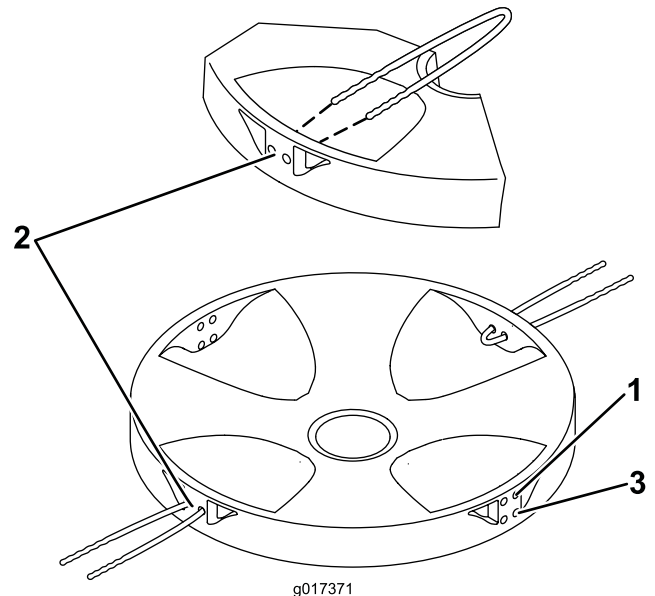

Figure 11

1. High
2. Middle
3. Low

Starting the Engine

1. Open the fuel tank vent by turning the vent knob at least 2 or 3 turns counterclockwise.
2. Turn the fuel valve to the ON position (Figure 12).

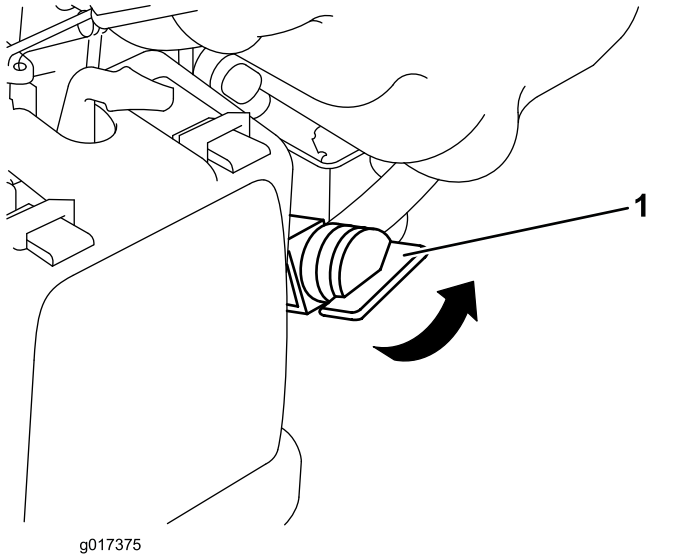

Figure 12

1. Fuel valve

3. Hold the operator-presence control against the handle.

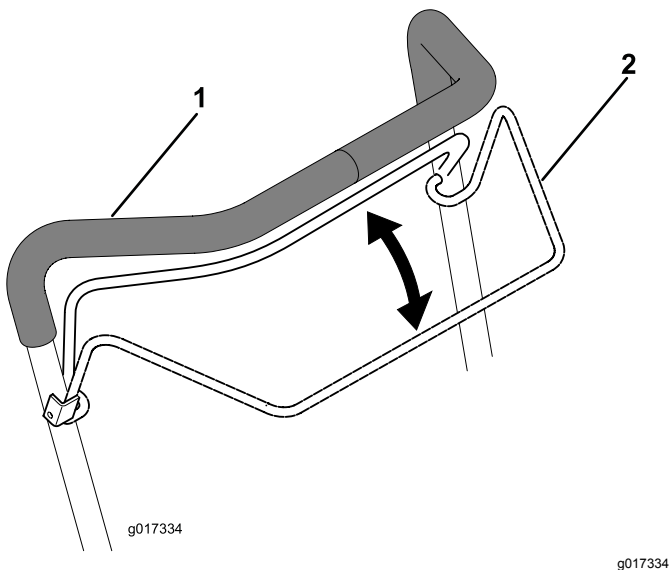

Figure 13

1. Handle
2. Operator-presence control

4. Place your foot on the deck and tilt the machine toward you (Figure 14).

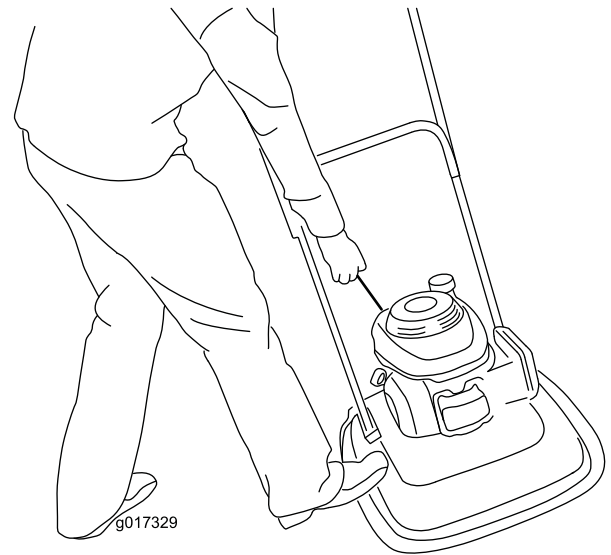

Figure 14

5. Pull the recoil-start handle.

Note: Do not allow the starter grip to snap back against the engine. Return it gently to prevent damage to the starter.

Note: If the machine does not start after several attempts, contact an Authorized Service Dealer.

Adjusting the Handle Position

Refer to [Figure 15](#) for the different handle positions.

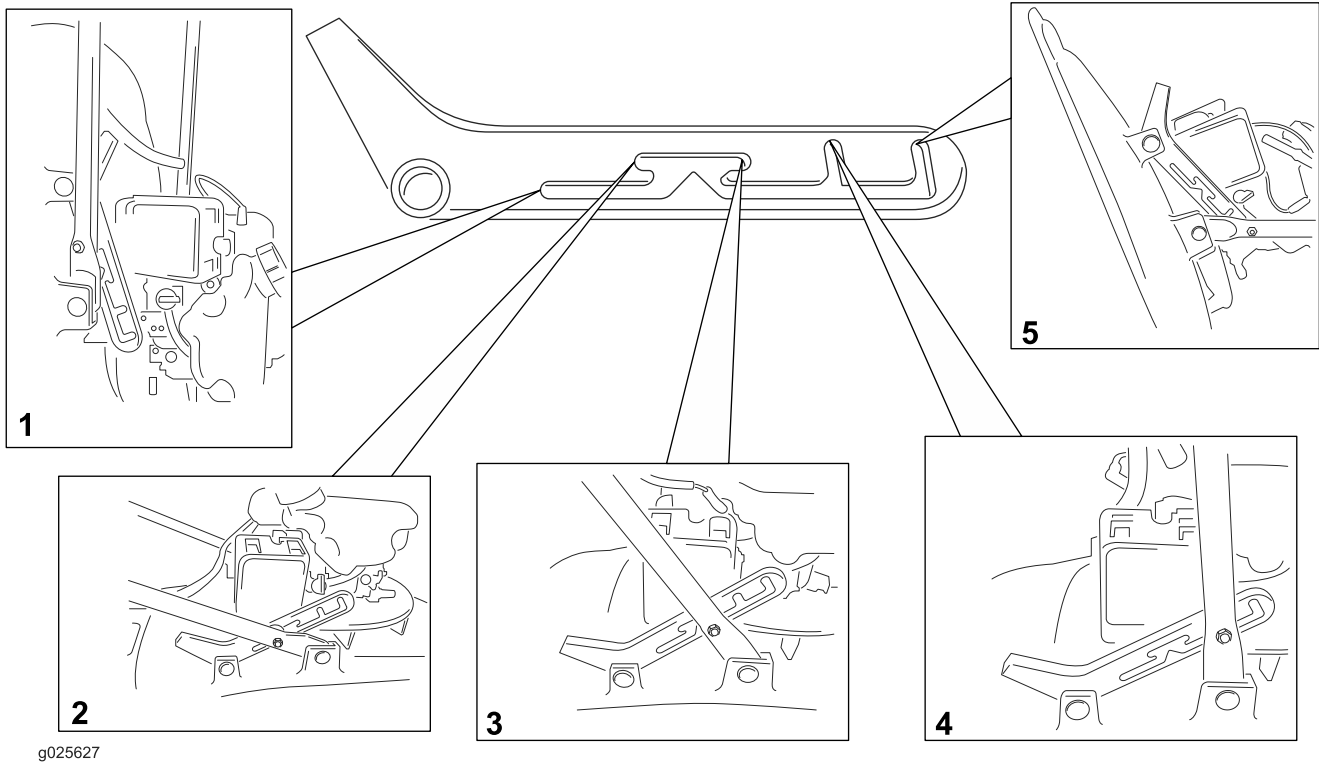

Figure 15

1. Hanging storage/transport position
2. Lower working position
3. Upper working position
4. Storage/transport position
5. Service position

Note: For proper storage procedure, refer to [Preparing the Machine for Storage \(page 17\)](#).

Shutting Off the Engine

Service Interval: Before each use or daily

To shut off the engine, release the operator-presence control ([Figure 16](#)).

Important: When you release the operator-presence control, the engine should shut off and the cutting line should stop within 5 seconds. If they do not stop properly, stop using your machine immediately and contact an Authorized Service Dealer.

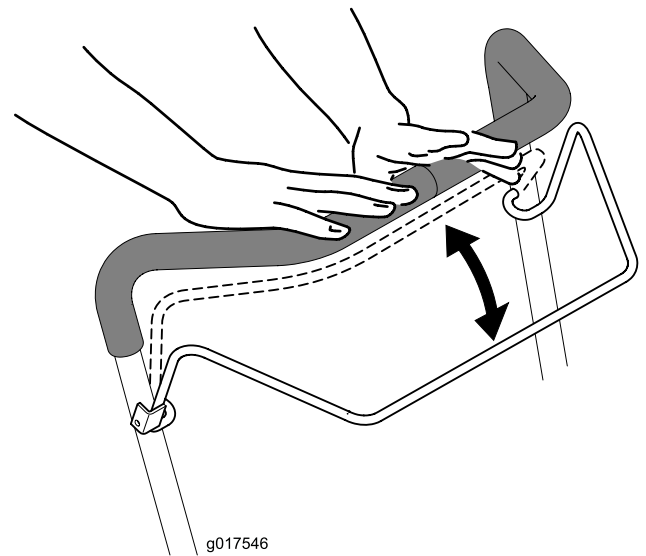

Figure 16

Operating Tips

General Mowing Tips

- Inspect the area where you will use the machine and remove all objects that the machine could throw.
- Avoid striking solid objects with the cutting line. Never deliberately mow over any object.
- If the machine strikes an object or starts to vibrate, immediately shut off the engine, disconnect the wire from the spark plug, and examine the machine for damage.
- For best performance, install new cutting lines before the cutting season begins.
- Replace the cutting line when necessary with a Toro replacement cutting line.
- Ensure that the replacement cutting line is the same length as the intact cutting line.

Cutting Grass

- Cut only about a third of the grass blade at a time. Do not cut below the highest setting (30 mm or 1.2 inches) unless the grass is sparse or it is late fall when grass growth begins to slow down. Refer to [Adjusting the Cutting Height \(page 10\)](#).
- Mowing grass over 15 cm (6 inches) in length is not recommended. If the grass is too long, the machine may plug and cause the engine to stall.
- Wet grass and leaves tend to clump on the yard and can cause the machine to plug or the engine to stall. Mow only in dry conditions, if possible.

⚠ WARNING

Wet grass or leaves can cause serious injury if you slip and contact the cutting line. Mow only in dry conditions, if possible.

- Be aware of a potential fire hazard in very dry conditions, follow all local fire warnings, and keep the machine free of dry grass and leaf debris.
- If the finished lawn appearance is unsatisfactory, try 1 or more of the following:
 - Inspect the cutting unit and/or replace the cutting line.
 - Walk at a slower pace while mowing.
 - Raise the cutting height on your machine.
 - Cut the grass more frequently.
 - Overlap cutting swaths instead of cutting a full swath with each pass.

Cutting Leaves

- After cutting the lawn, ensure that half of the lawn shows through the cut leaf cover. You may need to make more than a single pass over the leaves.
- Mowing grass over 15 cm (6 inches) in length is not recommended. If the leaf cover is too thick, the machine may plug and cause the engine to stall.
- Slow down your mowing speed if the machine does not cut the leaves finely enough.

Maintenance

Note: Determine the left and right sides of the machine from the normal operating position.

Recommended Maintenance Schedule(s)

Maintenance Service Interval	Maintenance Procedure
After the first 5 hours	<ul style="list-style-type: none"> Change the engine oil.
Before each use or daily	<ul style="list-style-type: none"> Check the engine oil level. Ensure that the engine shuts off within 5 seconds after releasing the operator-presence control. Clean grass clippings and dirt from the entire machine.
After each use	<ul style="list-style-type: none"> Clean grass clippings and dirt from the entire machine.
Every 100 hours	<ul style="list-style-type: none"> Check the spark plug and replace it if necessary.
Before storage	<ul style="list-style-type: none"> Empty the fuel tank before repairs as directed and before annual storage. Clean the cooling system; remove grass clippings, debris, or dirt from the engine air cooling fins and starter. Clean the system more frequently in dirty or high-chaff conditions.
Yearly	<ul style="list-style-type: none"> Replace the air filter; replace it more frequently in dusty operating conditions. Change the engine oil.

Preparing for Maintenance

⚠ WARNING

Tipping the machine may cause the fuel to leak. Fuel is flammable, explosive and can cause personal injury.

Run the engine dry or remove the fuel with a hand pump; never siphon.

- Shut off the engine and wait for all moving parts to stop.
- Disconnect the spark-plug wire from the spark plug (Figure 17) before performing any maintenance procedure.

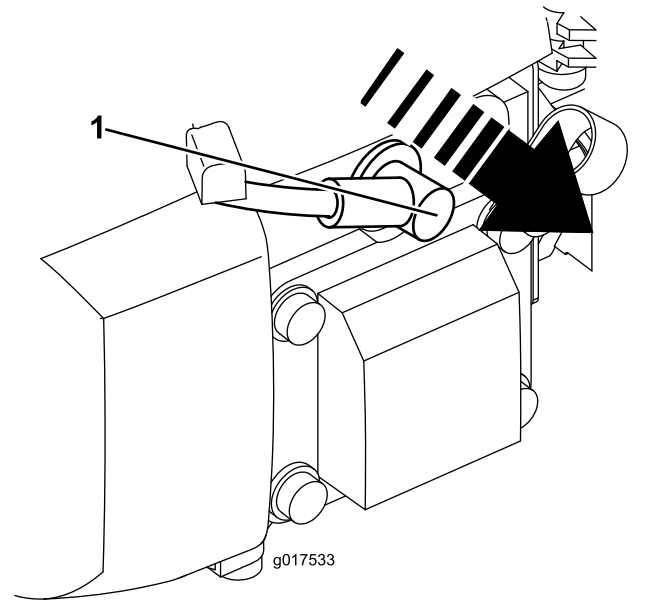

Figure 17

- Spark-plug wire

- After performing the maintenance procedure(s), connect the spark-plug wire to the spark plug.

Important: Always tip the machine onto its side, with the dipstick down. If the machine is tipped in another direction, oil may fill the valve train, requiring at least 30 minutes to drain.

Replacing the Air Cleaner

Service Interval: Yearly

1. Press down on the latch tabs on top of the air-cleaner cover (Figure 18).

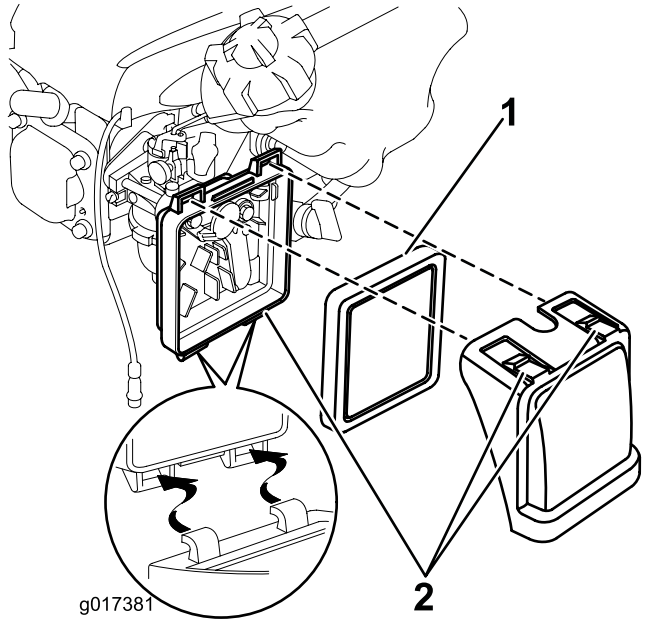

Figure 18

1. Filter
2. Latch tabs

2. Open the cover (Figure 18).
 3. Remove the filter (Figure 18).
 4. Inspect the air filter.
 - A. If the filter is damaged or is wet with oil or fuel, replace it.
 - B. If the filter is dirty, tap it on a hard surface several times or blow compressed air less than 207 kPa (30 psi) through the side of the filter that faces the engine.
- Note:** Do not brush the dirt off the filter; brushing forces dirt into the fibers.
5. Remove dirt from the air cleaner body and cover using a moist rag. **Do not wipe dirt into the air duct.**
 6. Insert the filter into the air cleaner (Figure 18).
 7. Install the cover (Figure 18).

Changing the Engine Oil

Service Interval: After the first 5 hours

Yearly

1. Run the engine a few minutes before changing the oil to warm it.

Note: Warm oil flows better and carries more contaminants.
2. Ensure that the fuel tank contains little or no fuel so that the fuel does not leak when you tip the machine onto its side.
3. Disconnect the wire from the spark plug. Refer to [Preparing for Maintenance \(page 14\)](#).
4. Remove the dipstick.
5. Tip the machine onto its side, with the dipstick down, to drain the used oil out through the oil-fill hole.
6. Return the machine to the operating position.
7. **Slowly** pour oil into the oil-fill hole, wait 3 minutes, and check the oil level on the dipstick by wiping the dipstick clean and then inserting, **but not screwing in**, the oil-fill cap into the hole.

Note: Max. fill: 0.59 L (20 fl oz), type: Multigrade Mineral 10W-30 oil with an API service classification of SF, SG, SH, SJ, SL, or higher.

Note: Fill the engine crankcase with oil until the dipstick indicates that the engine oil level is correct as shown in (Figure 19). If you overfill the engine with oil, remove the excess oil as directed in 5.

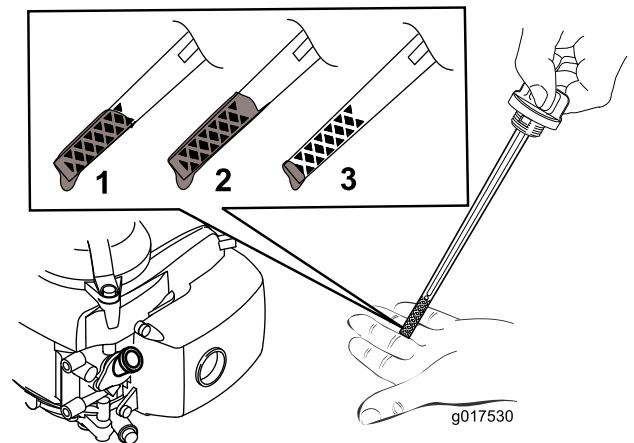

Figure 19

1. The oil level is at its maximum.
2. The oil level is too high—remove oil from the crankcase.
3. The oil level is too low—add oil to the crankcase.

8. Install the dipstick and hand tighten it securely.

- Dispose of the used oil properly at a local recycling center.

Servicing the Spark Plug

Service Interval: Every 100 hours

Use a **Champion RN9YC** spark plug or equivalent.

- Shut off the engine and wait for all moving parts to stop.
- Disconnect the wire from the spark plug.
- Clean around the spark plug.
- Remove the spark plug from the cylinder head.

Important: Replace a cracked, fouled, or dirty spark plug. Do not clean the electrodes because grit entering the cylinder can damage the engine.

- Set the gap on the plug to 0.76 mm (0.030 inch) as shown in [Figure 20](#).

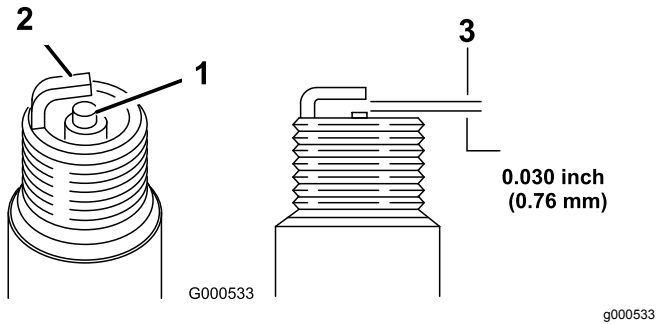

Figure 20

- Center-electrode insulator
- Side electrode
- Air gap (not to scale)

- Install the spark plug and the gasket seal.
- Torque the plug to 20 N-m (15 ft-lb).
- Connect the wire to the spark plug.

Replacing the Nylon Cutting String

- Turn the fuel valve to the OFF position and close the vent knob.
- Disconnect the wire from the spark plug.
- Turn the machine on its side, with the dipstick facing down.
- Wearing protective gloves**, remove the nylon cutting line.
- Place one length of nylon cutting line into the desired cutting height setting. Ensure that a second line of the same length is placed in the corresponding cutting height on the opposite side of the cutting disc.

Note: If using a spare reel, cut the line to a length of 200 mm (7-7/8 inches).

Cleaning the Machine

Service Interval: Before each use or daily

After each use

⚠ WARNING

The machine may dislodge material from under the machine housing.

- Wear eye protection.
 - Stay in the operating position (behind the handle).
 - Do not allow bystanders in the area.
- Tip the machine on its side, with the dipstick down.
 - Use a brush or compressed air to remove grass and debris from the exhaust guard, the top cowl, and the surrounding deck areas.

Storage

Store the machine in a cool, clean, dry place.

Preparing the Machine for Storage

⚠ WARNING

Fuel vapors can explode.

- Do not store fuel more than 30 days.
 - Do not store the machine in an enclosure near an open flame.
 - Allow the engine to cool before storing it.
1. On the last refueling of the year, add fuel stabilizer to the fuel as directed by the engine manufacturer.
 2. Run the machine until the engine shuts off from running out of fuel.
 3. Prime the engine and start it again.
 4. Allow the engine to run until it shuts off. When you can no longer start the engine, it is sufficiently dry.
 5. If you are storing the machine hanging on a wall, switch the fuel valve off and close the vent of the fuel cap.
 6. Disconnect the wire from the spark plug.
 7. Remove the spark plug, add 30 ml (1 fl oz) of oil through the spark-plug hole, and pull the starter rope **slowly** several times to distribute oil throughout the cylinder to prevent cylinder corrosion during the off-season.
 8. Install the spark plug and tighten it with a torque wrench to 20 N-m (15 ft-lb).
 9. Tighten all nuts, bolts, and screws.

Troubleshooting

Problem	Possible Cause	Corrective Action
The engine does not start.	<ol style="list-style-type: none"> 1. The wire is not connected to the spark plug. 2. The hole in the fuel-cap vent is plugged. 3. The spark plug is pitted, fouled, or the gap is incorrect. 4. The fuel tank is empty or the fuel system contains stale fuel. 	<ol style="list-style-type: none"> 1. Connect the wire to the spark plug. 2. Clean the hole in the fuel-cap vent or replace the fuel cap. 3. Check the spark plug and adjust the gap if necessary. Replace the spark plug if it is pitted, fouled, or cracked. 4. Drain and/or fill the fuel tank with fresh fuel. If the problem persists, contact an Authorized Service Dealer.
The engine starts hard or loses power.	<ol style="list-style-type: none"> 1. The fuel cap vent hole is plugged. 2. The air filter element is dirty and is restricting the air flow. 3. The underside of the machine housing contains clippings and debris. 4. The spark plug is pitted, fouled, or the gap is incorrect. 5. The engine oil level is too low, too high, or excessively dirty. 6. The fuel tank contains stale fuel. 	<ol style="list-style-type: none"> 1. Clean the fuel cap vent hole or replace the fuel cap. 2. Clean the air filter and/or replace the air filter. 3. Clean under the machine housing. 4. Check the spark plug and adjust the gap if necessary. Replace the spark plug if it is pitted, fouled, or cracked. 5. Check the engine oil. Change the oil if it is dirty; add or drain the oil to adjust the oil level to the Full mark on the dipstick. 6. Drain and fill the fuel tank with fresh fuel.
The engine runs rough.	<ol style="list-style-type: none"> 1. The wire is not connected to the spark plug. 2. The spark plug is pitted, fouled, or the gap is incorrect. 3. The air filter element is dirty and is restricting the air flow. 	<ol style="list-style-type: none"> 1. Connect the wire to the spark plug. 2. Check the spark plug and adjust the gap if necessary. Replace the spark plug if it is pitted, fouled, or cracked. 3. Clean the air filter and/or replace the air filter.
The machine or engine vibrates excessively.	<ol style="list-style-type: none"> 1. The underside of the machine housing contains clippings and debris. 2. The engine mounting bolts are loose. 3. The cutting disc bolt is loose. 	<ol style="list-style-type: none"> 1. Clean under the machine housing. 2. Tighten the engine mounting bolts. 3. Tighten the cutting disc bolt.
There is an uneven cutting pattern.	<ol style="list-style-type: none"> 1. You are mowing in the same pattern repeatedly. 2. The underside of the machine housing contains clippings and debris. 	<ol style="list-style-type: none"> 1. Change the mowing pattern. 2. Clean under the machine housing.

International Distributor List

Distributor:	Country:	Phone Number:	Distributor:	Country:	Phone Number:
Agrolanc Kft	Hungary	36 27 539 640	Maquiver S.A.	Colombia	57 1 236 4079
Balama Prima Engineering Equip.	Hong Kong	852 2155 2163	Maruyama Mfg. Co. Inc.	Japan	81 3 3252 2285
B-Ray Corporation	Korea	82 32 551 2076	Mountfield a.s.	Czech Republic	420 255 704 220
Casco Sales Company	Puerto Rico	787 788 8383	Mountfield a.s.	Slovakia	420 255 704 220
Ceres S.A.	Costa Rica	506 239 1138	Munditol S.A.	Argentina	54 11 4 821 9999
CSSC Turf Equipment (pvt) Ltd.	Sri Lanka	94 11 2746100	Norma Garden	Russia	7 495 411 61 20
Cyril Johnston & Co.	Northern Ireland	44 2890 813 121	Oslinger Turf Equipment SA	Ecuador	593 4 239 6970
Cyril Johnston & Co.	Republic of Ireland	44 2890 813 121	Oy Hako Ground and Garden Ab	Finland	358 987 00733
Equiver	Mexico	52 55 539 95444	Parkland Products Ltd.	New Zealand	64 3 34 93760
Femco S.A.	Guatemala	502 442 3277	Perfetto	Poland	48 61 8 208 416
ForGarder OU	Estonia	372 384 6060	Pratoverde SRL.	Italy	39 049 9128 128
G.Y.K. Company Ltd.	Japan	81 726 325 861	Prochaska & Cie	Austria	43 1 278 5100
Geomechaniki of Athens	Greece	30 10 935 0054	RT Cohen 2004 Ltd.	Israel	972 986 17979
Golf international Turizm	Turkey	90 216 336 5993	Riversa	Spain	34 9 52 83 7500
Guandong Golden Star	China	86 20 876 51338	Lely Turfcare	Denmark	45 66 109 200
Hako Ground and Garden	Sweden	46 35 10 0000	Solvart S.A.S.	France	33 1 30 81 77 00
Hako Ground and Garden	Norway	47 22 90 7760	Spypros Stavrinides Limited	Cyprus	357 22 434131
Hayter Limited (U.K.)	United Kingdom	44 1279 723 444	Surge Systems India Limited	India	91 1 292299901
Hydroturf Int. Co Dubai	United Arab Emirates	97 14 347 9479	T-Markt Logistics Ltd.	Hungary	36 26 525 500
Hydroturf Egypt LLC	Egypt	202 519 4308	Toro Australia	Australia	61 3 9580 7355
Irrimac	Portugal	351 21 238 8260	Toro Europe NV	Belgium	32 14 562 960
Irrigation Products Int'l Pvt Ltd.	India	0091 44 2449 4387	Valtech	Morocco	212 5 3766 3636
Jean Heybroek b.v.	Netherlands	31 30 639 4611	Victus Emak	Poland	48 61 823 8369

European Privacy Notice

The Information Toro Collects

Toro Warranty Company (Toro) respects your privacy. In order to process your warranty claim and contact you in the event of a product recall, we ask you to share certain personal information with us, either directly or through your local Toro company or dealer.

The Toro warranty system is hosted on servers located within the United States where privacy law may not provide the same protection as applies in your country.

BY SHARING YOUR PERSONAL INFORMATION WITH US, YOU ARE CONSENTING TO THE PROCESSING OF YOUR PERSONAL INFORMATION AS DESCRIBED IN THIS PRIVACY NOTICE.

The Way Toro Uses Information

Toro may use your personal information to process warranty claims, to contact you in the event of a product recall and for any other purpose which we tell you about. Toro may share your information with Toro's affiliates, dealers or other business partners in connection with any of these activities. We will not sell your personal information to any other company. We reserve the right to disclose personal information in order to comply with applicable laws and with requests by the appropriate authorities, to operate our systems properly or for our own protection or that of other users.

Retention of your Personal Information

We will keep your personal information as long as we need it for the purposes for which it was originally collected or for other legitimate purposes (such as regulatory compliance), or as required by applicable law.

Toro's Commitment to Security of Your Personal Information

We take reasonable precautions in order to protect the security of your personal information. We also take steps to maintain the accuracy and current status of personal information.

Access and Correction of your Personal Information

If you would like to review or correct your personal information, please contact us by email at legal@toro.com.

Australian Consumer Law

Australian customers will find details relating to the Australian Consumer Law either inside the box or at your local Toro Dealer.



The Toro Total Coverage Guarantee

A Limited Warranty

Conditions and Products Covered

The Toro® Company and its affiliate, Toro Warranty Company, pursuant to an agreement between them, jointly warrant your Toro Commercial product ("Product") to be free from defects in materials or workmanship for two years or 1500 operational hours*, whichever occurs first. This warranty is applicable to all products with the exception of Aerators (refer to separate warranty statements for these products). Where a warrantable condition exists, we will repair the Product at no cost to you including diagnostics, labor, parts, and transportation. This warranty begins on the date the Product is delivered to the original retail purchaser.

* Product equipped with an hour meter.

Instructions for Obtaining Warranty Service

You are responsible for notifying the Commercial Products Distributor or Authorized Commercial Products Dealer from whom you purchased the Product as soon as you believe a warrantable condition exists. If you need help locating a Commercial Products Distributor or Authorized Dealer, or if you have questions regarding your warranty rights or responsibilities, you may contact us at:

Commercial Products Service Department
Toro Warranty Company
8111 Lyndale Avenue South
Bloomington, MN 55420-1196
E-mail: commercial.warranty@toro.com

Owner Responsibilities

As the Product owner, you are responsible for required maintenance and adjustments stated in your Operator's Manual. Failure to perform required maintenance and adjustments can be grounds for disallowing a warranty claim.

Items and Conditions Not Covered

Not all product failures or malfunctions that occur during the warranty period are defects in materials or workmanship. This warranty does not cover the following:

- Product failures which result from the use of non-Toro replacement parts, or from installation and use of add-on, or modified non-Toro branded accessories and products. A separate warranty may be provided by the manufacturer of these items.
- Product failures which result from failure to perform recommended maintenance and/or adjustments. Failure to properly maintain your Toro product per the Recommended Maintenance listed in the *Operator's Manual* can result in claims for warranty being denied.
- Product failures which result from operating the Product in an abusive, negligent or reckless manner.
- Parts subject to consumption through use unless found to be defective. Examples of parts which are consumed, or used up, during normal Product operation include, but are not limited to, brakes pads and linings, clutch linings, blades, reels, bed knives, tines, castor wheels, tires, filters, belts, and certain sprayer components such as diaphragms, nozzles, and check valves, etc.
- Failures caused by outside influence. Items considered to be outside influence include, but are not limited to, weather, storage practices,

contamination, use of unapproved coolants, lubricants, additives, fertilizers, water, or chemicals, etc.

- Normal noise, vibration, wear and tear, and deterioration.
- Normal "wear and tear" includes, but is not limited to, damage to seats due to wear or abrasion, worn painted surfaces, scratched decals or windows, etc.

Parts

Parts scheduled for replacement as required maintenance are warranted for the period of time up to the scheduled replacement time for that part. Parts replaced under this warranty are covered for the duration of the original product warranty and become the property of Toro. Toro will make the final decision whether to repair any existing part or assembly or replace it. Toro may use remanufactured parts for warranty repairs.

Note Regarding Deep Cycle Battery Warranty:

Deep cycle batteries have a specified total number of kilowatt-hours they can deliver during their lifetime. Operating, recharging, and maintenance techniques can extend or reduce total battery life. As the batteries in this product are consumed, the amount of useful work between charging intervals will slowly decrease until the battery is completely worn out. Replacement of worn out batteries, due to normal consumption, is the responsibility of the product owner. Battery replacement may be required during the normal product warranty period at owner's expense.

Maintenance is at Owner's Expense

Engine tune-up, lubrication cleaning and polishing, replacement of Items and Conditions Not Covered filters, coolant, and completing Recommended Maintenance are some of the normal services Toro products require that are at the owner's expense.

General Conditions

Repair by an Authorized Toro Distributor or Dealer is your sole remedy under this warranty.

Neither The Toro Company nor Toro Warranty Company is liable for indirect, incidental or consequential damages in connection with the use of the Toro Products covered by this warranty, including any cost or expense of providing substitute equipment or service during reasonable periods of malfunction or non-use pending completion of repairs under this warranty. Except for the Emissions warranty referenced below, if applicable, there is no other express warranty.

All implied warranties of merchantability and fitness for use are limited to the duration of this express warranty. Some states do not allow exclusions of incidental or consequential damages, or limitations on how long an implied warranty lasts, so the above exclusions and limitations may not apply to you.

This warranty gives you specific legal rights, and you may also have other rights which vary from state to state.

Countries Other than the United States or Canada

Customers should contact their Toro Distributor (Dealer) to obtain guarantee policies for your country, province, or state. If for any reason you are dissatisfied with your Distributor's service or have difficulty obtaining guarantee information, contact the Toro importer. If all other remedies fail, you may contact us at Toro Warranty Company.