

TORO[®]

MODEL NO. 30722—50001 & UP

MODEL NO. 30710—50001 & UP

**OPERATOR'S
MANUAL**

72" CUTTING UNIT

**ONLY COPY
DO NOT REMOVE**

Tech. Publications



FOREWORD

FOREWORD

The 72" cutting deck has advanced concepts in engineering, design and safety; and if maintained properly, will give excellent service.



Certain information in this manual is emphasized. DANGER, WARNING and CAUTION identify personal safety related information. IMPORTANT identifies mechanical information demanding special attention. Be sure to read this directive because it deals with the possibility of damaging a part or parts of the machine. NOTE identifies general information worthy of special attention.

Table of Contents

| | Page |
|--|-------|
| PECIFICATIONS | 6 |
| BEFORE OPERATING | 11 |
| Adjusting Height-of-Cut | 11 |
| Adjusting The rollers | 11 |
| Adjust Skid | 11 |
| Check Lubricant In The gear Box | 11 |
| OPERATING INSTRUCTIONS | 12 |
| Grass Deflector | 12 |
| Tension Spring Adjustment | 12 |
| LUBRICATION | 13 |
| Grease Bearings And Bushings | 13 |
| MAINTENANCE | 14-21 |
| Trouble Shooting | 14 |
| Separating Cutting Unit From The traction Unit | 15 |
| PTO Shaft Removal | 15 |
| Servicing Bushings in The castor Arms | 15 |
| Servicing The castor Wheel and Bearing | 16 |
| Checking for Bent Blade | 16 |
| Replacing Cutter Blade | 17 |
| Checking Sail and Sharpening Cutter Blade | 17 |
| Correcting Cutting Unit Mismatch | 18 |
| Replacing Grass Deflector | 19 |
| Adjusting Cover Latches | 19 |
| Adjusting Idler Pulley | 19 |
| Replacing Drive Belt | 19 |
| IDENTIFICATION AND ORDERING | 22 |
| MAINTENANCE CHART | 22-23 |

Safety

Training

1. Read the instructions carefully. Be familiar with the controls and the proper use of the equipment.
2. Never allow children or people unfamiliar with these instructions to use the lawnmower. Local regulations may restrict the age of the operator.
3. Never mow while people, especially children, or pets are nearby.
4. Keep in mind that the operator or user is responsible for accidents or hazards occurring to other people or their property.
5. Do not carry passengers.
6. All drivers should seek and obtain professional and practical instruction. Such instruction should emphasize:
 - the need for care and concentration when working with ride-on machines;
 - control of a ride on machine sliding on a slope will not be regained by the application of the brake. The main reasons for loss of control are:
 - insufficient wheel grip;
 - being driven too fast;
 - inadequate braking;
 - the type of machine is unsuitable for its task;
 - lack of awareness of the effects of ground conditions, especially slopes;

Preparation

1. While mowing, always wear substantial footwear and long trousers. Do not operate the equipment when barefoot or wearing open sandals.
2. Thoroughly inspect the area where the equipment is to be used and remove all objects which may be thrown by the machine.

3. **WARNING—Petrol is highly flammable.**

- Store fuel in containers specifically designed for this purpose.
- Refuel outdoors only and do not smoke while refueling.
- Add fuel before starting the engine. Never remove the cap of the fuel tank or add petrol while the engine is running or when the engine is hot.
- If petrol is spilled, do not attempt to start the engine but move the machine away from the area of spillage and avoid creating any source of ignition until petrol vapors have dissipated.
- Replace all fuel tanks and container caps securely.

4. Replace faulty silencers.

5. Before using, always visually inspect to see that the blades, blade bolts and cutter assembly are not worn or damaged. Replace worn or damaged blades and bolts in sets to preserve balance.

6. On multi-bladed machines, take care as rotating one blade can cause other blades to rotate.

Operation

1. Do not operate the engine in a confined space where dangerous carbon monoxide fumes can collect.
2. Mow only in daylight or in good artificial light.
3. Before attempting to start the engine, disengage all blade attachment clutches and shift into neutral.
4. Do not use on slopes of more than:
 - Never mow side hills over 5°
 - Never mow uphill over 10°
 - Never mow downhill over 15°
5. Remember there is no such thing as a “safe” slope.

Travel on grass slopes requires particular care. To guard against overturning:

- do not stop or start suddenly when going up or downhill;
 - engage clutch slowly, always keep machine in gear, especially when travelling downhill;
 - machine speeds should be kept low on slopes and during tight turns;
 - stay alert for bumps and hollows and other hidden hazards;
 - never mow across the face of the slope, unless the lawnmower is designed for this purpose.
6. Use care when pulling loads or using heavy equipment.
 - Use only approved drawbar hitch points.
 - Limit loads to those you can safely control.
 - Do not turn sharply. Use care when reversing.
 - Use counterweight(s) or wheel weights when suggested in the instruction handbook .
 7. Watch out for traffic when crossing or near roadways.
 8. Stop the blades rotating before crossing surfaces other than grass.
 9. When using any attachments, never direct discharge of material toward bystanders nor allow anyone near the machine while in operation .
 10. Never operate the lawnmower with defective guards, shields or without safety protective devices in place.
 11. Do not change the engine governor settings or over-speed the engine. Operating the engine at excessive speeds may increase the hazard of personal injury.
 12. Before leaving the operator's position:
 - disengage the power take-off and lower the attachments;
 - change into neutral and set the parking brake;
 - stop the engine and remove the key.

13. Disengage drive to attachments, stop the engine, and disconnect the spark plug wire(s) or remove the ignition key
 - before cleaning blockages or unclogging chute;
 - before checking, cleaning or working on the lawnmower;
 - after striking a foreign object. Inspect the lawnmower for damage and make repairs before restarting and operating the equipment;
 - if the machine starts to vibrate abnormally (check immediately).
14. Disengage drive to attachments when transporting or not in use.
15. Stop the engine and disengage drive to attachment
 - before refueling;
 - before removing the grass catcher;
 - before making height adjustment unless adjustment can be made from the operator's position.
16. Reduce the throttle setting during engine runout and, if the engine is provided with a shutoff valve, turn the fuel off at the conclusion of mowing.

Maintenance and Storage

1. Keep all nuts, bolts and screws tight to be sure the equipment is in safe working condition.
2. Never store the equipment with petrol in the tank inside a building where fumes may reach an open flame or spark.
3. Allow the engine to cool before storing in any enclosure.
4. To reduce the fire hazard, keep the engine, silencer, battery compartment and petrol storage area free of grass, leaves, or excessive grease.
5. Check the grass catcher frequently for wear or deterioration.
6. Replace worn or damaged parts for safety.

7. If the fuel tank has to be drained, this should be done outdoors
8. On multi-bladed machines, take care as rotating one blade can cause other blades to rotate.
9. When machine is to be parked, stored or left unattended, lower the cutting means unless a positive mechanical lock is used.

Symbol Glossary

Safety alert symbol



Dismemberment—Mower in rearward position.



Safety alert symbol



Stay a safe distance from the machine.



Read operator's manual



Stay a safe distance from the mower.

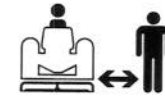

Consult technical manual for proper service procedures



Keep children a safe distance from the machine.



Thrown or flying objects—whole body exposure



Machine rollover—side hill



Thrown or flying objects—rotary side-mounted mower. Keep deflector shield in place.



Machine rollover—up hill



Severing toes or foot—mower blade



Machine rollover—down hill



Severing fingers or hand—mower blade



Machine rollover—roll over protection system













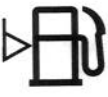





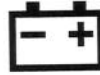







Rotating blade can cut off toes or fingers. Stay clear of blade as long as the engine is running.

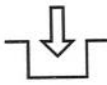

Do not open or remove safety shields while the engine is running.

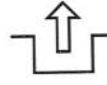

| | | | |
|---------------------------------|---|----------------------------|---|
| Fast |  | Fuel |  |
| Slow |  | Fuel level |  |
| Decreasing/increasing |  | Volume empty |  |
| On/Run |  | Volume full |  |
| Off/Stop |  | Battery charging condition |  |
| Engine |  | Head lights—Main/high beam |  |
| Engine start |  | Brake system |  |
| Engine stop |  | Parking brake |  |
| Choke |  | Clutch |  |
| Engine temperature |  | PTO (Power Take Off) |  |
| Engine lubricating oil pressure |  | Engage |  |
| Engine lubricating oil pressure |  | Disengage |  |
| | | Unlock |  |
| | | Lock |  |

Cutting element—basic symbol



Cutting element—height adjustment



Cutting unit—lower



Cutting unit—raised



Cutting or entanglement of foot—rotating auger



Severing of fingers or hand—impeller blade



Keep a safe distance from snowthrower.



Stay a safe distance from snowthrower.



Tractors must be equipped with 45 kg rear wheel weight with this attachment installed.



Machine rollover protection system snowthrower



Severing of hand—rotating knives



Severing of foot—rotating knives



Riding on this machine is allowed only on a passenger seat and only if the driver's view is not hindered.



Crushing of fingers or hands—force applied from the side



Kickback or upward motion—stored energy



Shut off engine and remove key before performing maintenance or repair work.



Machine travel direction—combined



Low

High

Reverse

Neutral

First gear

Second gear

Third gear up to a maximum number of forward gears.

L
H
R
N
1
2
3

Specifications

Width of Cut: (1.816 m)

Height of Cut: Adjustable from 25 to 102 mm 13 mm increments.

Cutter Housing: Both cutter housings are made from 11-gauge (13 mm) steel and reinforced with 89 mm x 4.76 mm channel iron .

Cutting Unit Drive: The gear box is driven by the PTO shaft. Power is transmitted to the blades by three B-section belts. The spindle shafts are 32 mm in diameter and supported by two externally sealed, greaseable, tapered roller bearings.

Cutting Unit: Front-mounted cutting units have front and rear cast-er wheels, three heat-treated steel blades 0.63 m long and 6 mm thick.

Caster Wheels: Two front caster wheels have roller bearings with 260.4 mm x 82.55 mm hard rubber tires. The rear wheels have roller bearings and 152.8 mm x 63.5 mm hard rubber tires.

Blade Tip Speed: At 3200 engine rpm, blade tip speed is 76.2 m/sec.

Cutting Unit Lift: Cutting units are lifted by a hydraulic cylinder that has 64 mm bore and 82 mm stroke.

Dimensions and Weights:

Model 30722 Width: 85-1/2 in. (2.17 m)

Weight: 400 lb (181.4 Kg)

Model 30710 Width: 76 in. (1.93 m)

Weight: 415 lb (188.2 Kg)

Before Operating

CHECK THE LEVEL OF LUBRICANT IN THE GEAR BOX

The gear box is designed to operate on SAE 80-90 weight gear lube. Although the gear box is shipped with lubricant from the factory, check the level before operating the cutting unit.

1. Position the machine and cutting unit on a level surface.
Lower the cutting unit onto the level surface.

- Remove the check plug from the side of the gear box (Fig 15) and make sure the lubricant is up to the bottom of the hole. If the level of lubricant is low, remove the fill plug on top of the gear case and add enough lubricant to bring it up to the bottom of the hole in the side

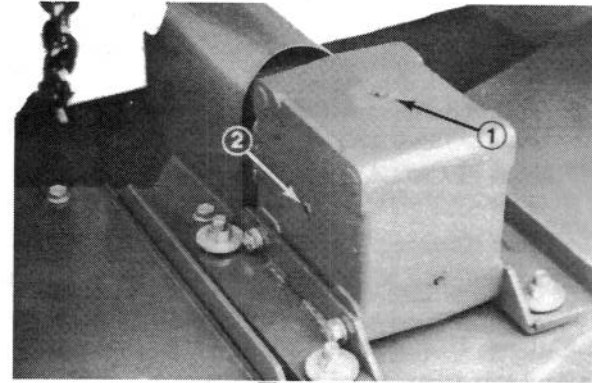

Figure 1
1. Filler plug
2. Check plug

Operating Instructions

ADJUSTING HEIGHT OF CUT

The height of cut is adjustable from 25 to 102 mm in 13 mm increments, by adding or removing an equal number of spacers on the front and rear caster forks. The height-of-cut chart below gives the combinations of spacers to use for all height-of-cut settings.

Note: 6 mm spacers are available and can be ordered from your Toro distributor by Toro Part No. 27-1040. (Quantity-8).

| Height-of-Cut Setting | Spacers Below Caster Arm | |
|-----------------------|--------------------------|------|
| | Front | Rear |
| 25 mm | 0 | 0 |
| 38 mm | 1 | 1 |
| 51 mm | 2 | 2 |
| 64 mm | 3 | 3 |
| 76 mm | 4 | 4 |
| 89 mm | 5 | 5 |
| 102 mm | 6 | 6 |

Note: A more optimum cutting appearance of the turf can be achieved in the lower heights of cut by lowering the rear of the cutting unit. Accomplish this by relocating the rear caster wheel axles in the upper hole of the caster forks (Fig. 3). Replace the axles into the lower caster fork holes for higher height-of-cut settings where optimum cutting appearance is not required.

IMPORTANT: Do not attempt to cut off more than 25 mm of

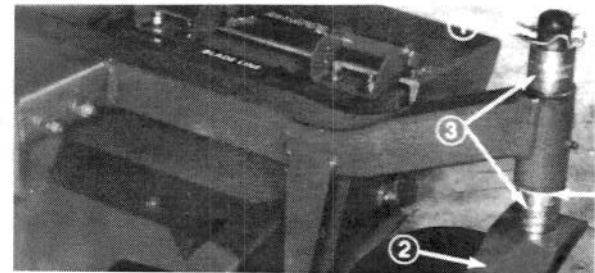

Figure 2
1. lynch pin
2. Large front castor
3. Spacers
4. Washer

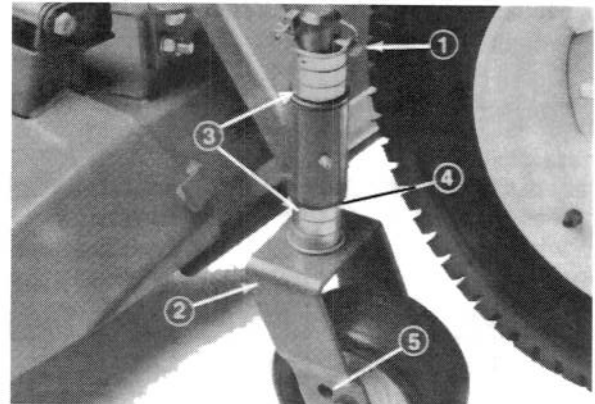

Figure 3
1. lynch pin
2. Small (rear castor)
3. Spacers
4. Washer
5. For 25 mm height of cut only

the grass blades in the 25 mm height-of-cut setting with the rear of the cutting unit lowered, as this may cause the engine to labor excessively.

1. Start the engine and raise the cutting unit so the front-caster height of cut can be changed. Stop the engine after the cutting unit is raised. The rear caster height of cut can be changed with the cutting unit lowered.
2. Squeeze the back of the wire and rotate wire on the lynch pin. Pull the pin out of the caster spindle. Slide spacers onto the caster spindle to get the desired height of cut (Fig. 2 and 3). Then slide the washer onto the spindle.
3. Push the caster spindle through the caster arm. Slide any remaining spacers onto the spindle (Fig. 2 and 3). Install lynch pin to retain parts in place.

Note: When the cutting unit is used in the 25 mm or 38 mm height-of-cut setting, the front and rear rollers must be positioned in the upper bracket holes.

GRASS DEFLECTOR



WARNING

The grass deflector is a safety device that diverts grass and other foreign objects being discharged downward. WE STRONGLY RECOMMEND THAT THE DEFLECTOR BE IN ITS NORMAL OPERATING POSITION WHENEVER THE CUTTING UNIT IS ENGAGED. NEVER OPERATE THE CUTTING UNIT WITH THE DEFLECTOR REMOVED FROM THE CUTTING UNIT OR WITH IT ITED/BLOCKED IN A RAISED POSITION. IF YOU DO, THE BLADES COULD THEN THROW DEBRIS A CONSIDERABLE DISTANCE WITH SUFFICIENT FORCE TO CAUSE PERSONAL INJURY OR DAMAGE PROPERTY. If the grass deflector is damaged, repair or replace the affected parts.

Note: The deflector is spring loaded into its downward normal operating position but the operator can temporarily swing it out of the way to facilitate loading in a trailer or other maneuvers.

IMPORTANT: If your traction unit is to be used with a Rear Discharge Cutting Unit and is not already equipped with the Donaldson air cleaner, it should be equipped by installing Air Cleaner Kit 27-7090.

CAUTION: This product may exceed noise levels of 85 dB(A) at the operator position. Ear protectors are recommended, for pro-

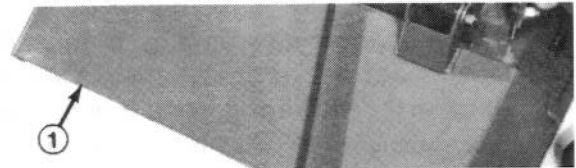

Figure 4

1. Deflector in lowest position

longed exposure, to reduce the potential of permanent hearing loss.

Maintenance

LUBRICATION

GREASING BEARINGS, BUSHINGS AND GEAR BOX

The cutting unit must be lubricated regularly. If the machine is operated under normal conditions, lubricate the caster bearings and bushings with No. 2 general purpose lithium grease or molybdenum base grease, after every 8 hours of operation or daily, whichever comes first. All other bearings, bushings and the gear box must be lubricated after every 50 hours of operation.

1. The cutting unit has bearings and bushings that must be lubricated, and these lubrication points are: the caster spindle bushings (Fig. 4); caster wheel bearings (Fig. 4 and 5); blade spindle bearings (Fig. 6); right and left push arm ball joints (Fig. 6).
2. Lower the cutting unit so the caster wheels are on a level surface. Remove check plug (Fig. 6) from the side of gear box and check the level of lubricant. If the level of lubricant is low, remove the fill plug on top of gear box and add SAE 80-90 wt gear lube until the level is up to the bottom of check hole.

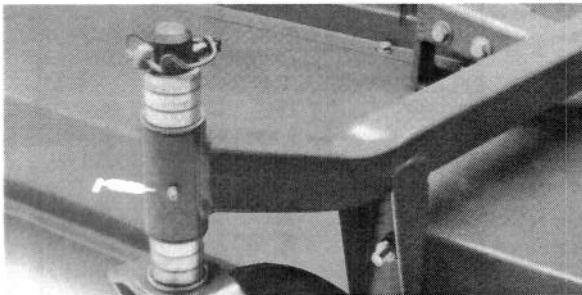

Figure 5

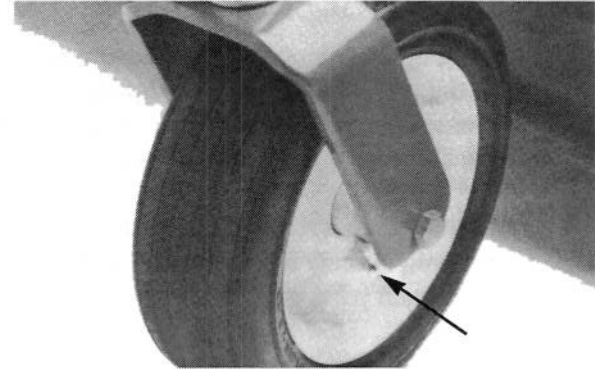

Figure 6

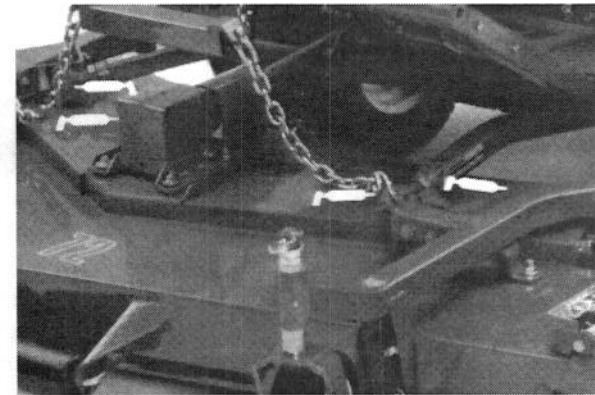

Figure 7

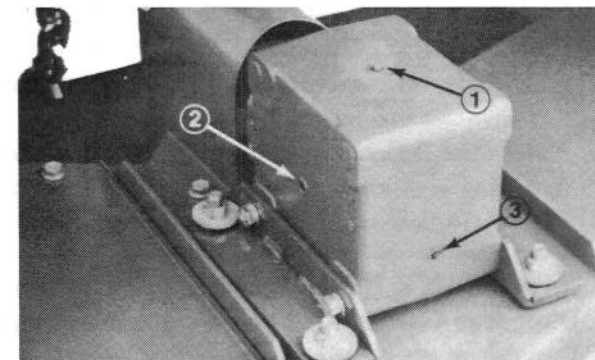
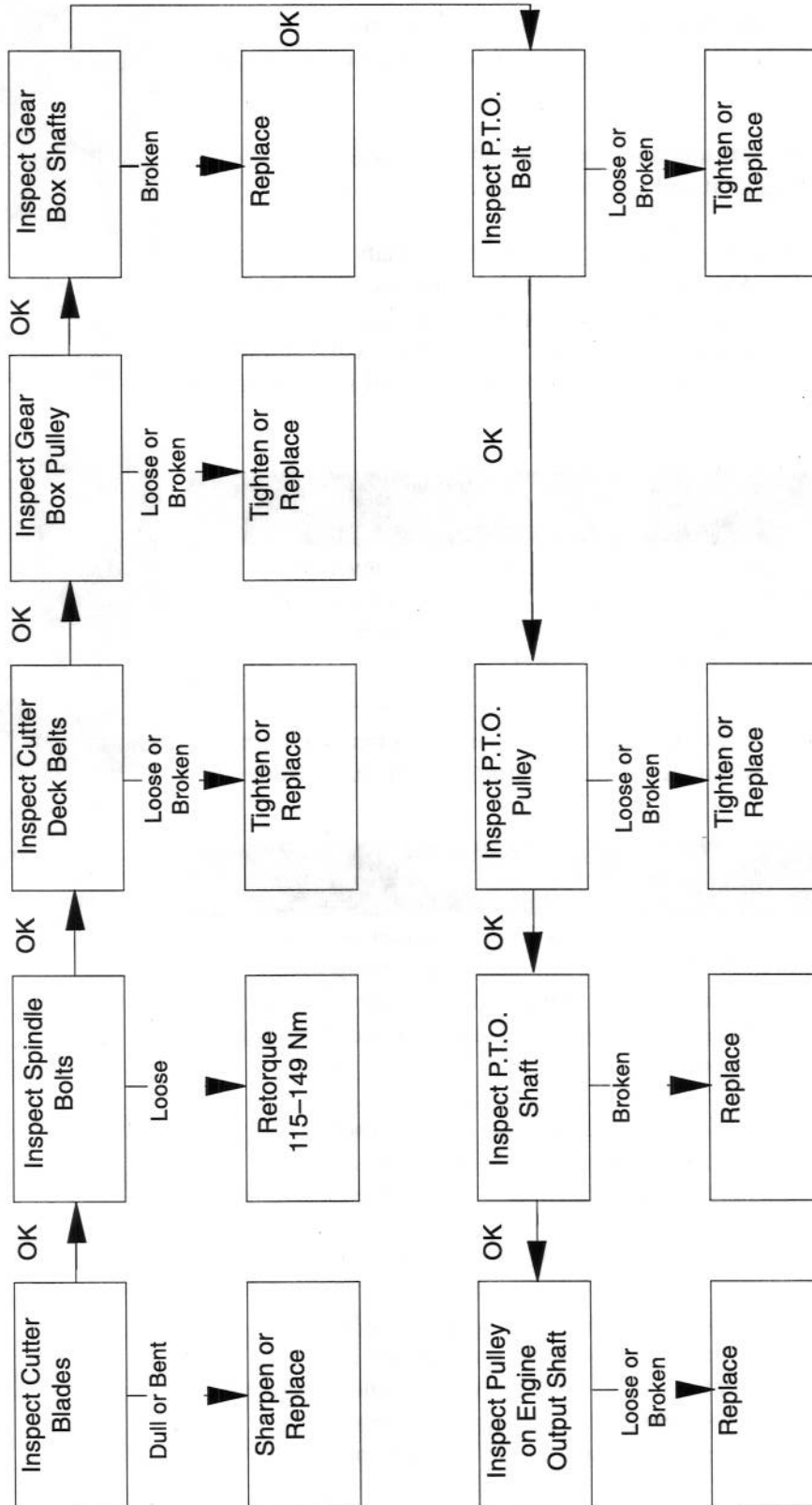

Figure 8

1. Filler plug
2. Check plug
3. Drain plug

TROUBLESHOOTING

UNIT WILL NOT CUT OR CUTS POORLY



SEPARATING THE CUTTING UNIT FROM TRACTION UNIT

1. Position the machine on a level surface, lower the cutting unit to the shop floor, shut the engine off and engage the parking brake.
2. Remove the self-tapping screws securing the shield to the top of the cutting unit and set the shield aside.
3. Drive the roll pin out of the yoke and input shaft of the gear box (Fig. 9). Also, loosen the capscrews and locknuts. Slide the yoke off the input shaft. If the traction unit will be used without the cutting unit, drive the roll pin out of the yoke at the PTO pivot shaft and remove the entire universal shaft from the traction unit.

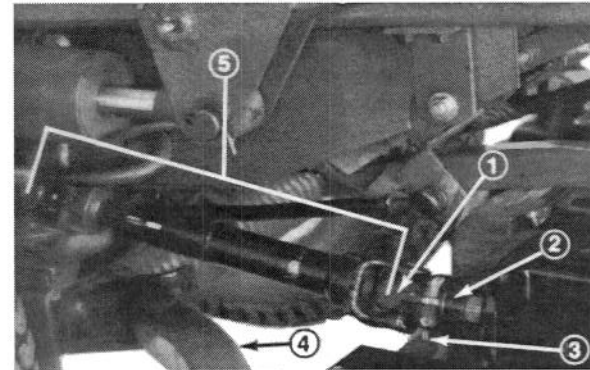

Figure 9

1. PTO yoke
2. Roll pin
3. Capscrews & locknuts
4. Right. push arm
5. Yokes in phase

! DANGER

Do not start the engine and engage the PTO lever when the PTO shaft is not connected to the gear box on the cutting unit. If the engine is started and the PTO shaft is allowed to rotate, serious injury could result.

4. Disconnect the spring from the lift cylinder cotter pin. Remove the cotter pins and clevis pins securing the lift chains to the lift arm.

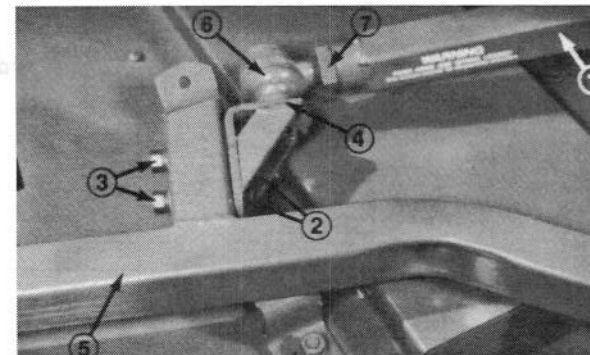

Figure 10

1. Left. push arm
2. Capscrew and flatwasher
3. Flange locknut
4. Ball joint mount
5. Caster arm
6. Ball joint
7. Jam nut

! WARNING

Since the right hand push arm is springloaded to about 100 pounds (445 N) and left hand push arm is spring-loaded to about 150 pounds (667 N), a helper is needed to release push arms from the cutting unit. Sudden release of the push arms could cause injury.

5. Have a helper push down on the right push arm while you remove the capscrews, flatwashers, lockwashers and nuts securing ball joint mount to the caster arm on the cutting unit (Fig. 9). Now the helper can carefully allow push arm to move upward, which will gradually release the spring load.
6. Have a helper push down on the left push arm while you remove the capscrews, flatwashers, lockwashers and nuts securing ball joint mount to mount bracket on the cutting unit (Fig. 10). Now the helper can carefully allow push arm to move upward which will gradually release the spring load.

7. Roll the cutting unit away from the traction unit.

MOUNTING THE CUTTING UNIT TO THE TRACTION UNIT

1. Position the machine on a level surface and shut the engine off.
2. Move the cutting unit into position in front of traction unit.



WARNING

Since the right hand push arm is springloaded to about 100 pounds (445 N) and left hand push arm is spring-loaded to about 150 pounds (667 N), a helper is needed to release push arms from the cutting unit. Sudden release of the push arms could cause injury.

3. Slide a large flatwasher onto both capscrews.
4. Have a helper carefully push down on right hand push arm until the holes in ball joint mount line up with the holes in the caster arm. Secure ball joint mount to the caster arm with two capscrews w/large flatwashers, one flatwasher, two lockwashers and nuts. Heads of capscrews and large flatwashers must be on outside of the caster arm.
5. Slide the flatwashers onto the two capscrews.
6. Have a helper carefully push down on left hand push arm until the holes in ball joint mount are in line with the holes in mount bracket on the cutting unit. Immediately slide 100 x 100 mm block of wood between top of push arm and underside of chassis.

Make sure wooden block does not slip out accidentally.

7. Secure ball joint mount to mount bracket with two capscrews, flatwashers, and flange locknuts. The heads of the capscrews and flatwashers must contact the ball joint mount.
8. Connect the PTO shaft to gear box with roll pin and (2) capscrews and nuts, install shield and connect lift chains to lift arm: refer to *Connect PTO Shaft and Install Lift Chains*.

REPLACING BLADE DRIVE BELTS

1. Lower the cutting unit to the shop floor. Remove covers on top of the cutting unit and set covers aside. Loosen idler pulleys to release tension of belts.
2. Remove carriage bolts, lockwashers and nuts holding gear box in place. Lift gear box off mounting plate and lay it on top of the cutting unit.
3. Remove belts from the spindle pulleys.
4. Mount a belt on lower pulley groove of left spindle, slide belt under belt idler mount plate and install around center spindle pulley. Tension belt by levering idler pulley against belt and tighten idler pulley flange nut (Fig. 12).
5. Place the right spindle belt under the gear box mount plate and the opposite end on top of the right spindle pulley. Place the left spindle belt under the gear box mount plate and the opposite end on top of the left spindle pulley. Mount the gear box and loop the belts around the gear box pulley.
6. Feed the right and left spindle belts over the pulleys by rotating the cutter blades. Tighten the gear box mounting fasteners.
7. Tension idler pulleys against both belts. Install covers on top of the cutting unit.

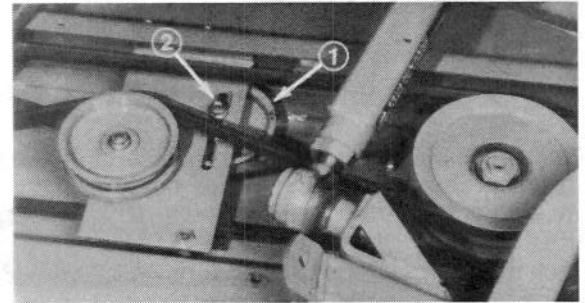

Figure 11

1. Lower belt idler
2. Flange nut

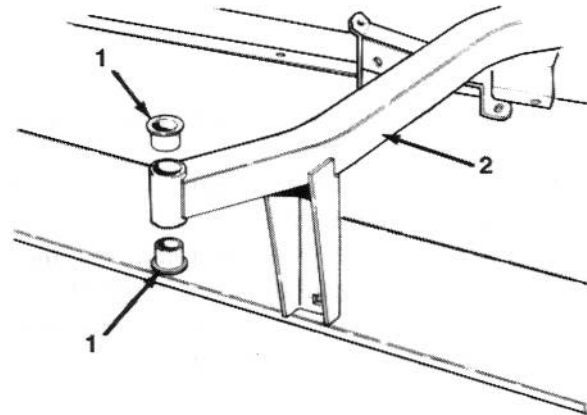

Figure 12

1. Bushing
2. Caster Arm

REMOVING THE CUTTER BLADE

The blade must be replaced if a solid object is hit, the blade is out of balance, worn or bent. Always use genuine TORO replacement blades to ensure safety and optimum performance. Never use blades made by other manufacturers because they could be dangerous.

CAUTION

Do not try to straighten a blade that is bent, and never weld a broken or cracked blade. Always use a new TORO blade to assure safety.

1. Raise the cutting unit to the highest position, shut the engine off and engage the parking brake. Block the cutting unit to prevent it from falling accidentally.

2. Grasp the end of the blade using a rag or thickly padded glove. Remove the special screw, belleville washer and blade from the spindle assembly (Fig. 13).

Tighten the special screw to 102 to 136 N-m.

INSPECTING AND SHARPENING THE BLADE

1. Raise the cutting unit to highest position, shut the engine off and engage the parking brake. Block the cutting unit to prevent it from falling accidentally.
2. Examine the cutting ends of the blade carefully, especially where the flat and curved parts of the blade meet (Fig. 14A). Since sand and abrasive material can wear away the metal that connects the flat and curved parts of the blade, check the blade before using the machine. If any wear is noticed (Fig. 14B), replace the blade: refer to *Removing The Cutter Blade*.

WARNING

If the blade is allowed to wear, a slot will form between the sail and the flat part of the blade (Fig. 14 C). Eventually a piece of the blade may break off and be thrown from under the housing, possibly resulting in serious injury to yourself or to bystanders.

3. Examine the cutting edges of all blades. Sharpen the cutting edges if they are dull or nicked. Sharpen only the top side of the cutting edge and maintain the original cutting angle to assure sharpness (Fig. 15). The blade will remain balanced if same amount of metal is removed from both cutting edges.
4. To check the blade for being straight and parallel, lay it on a level surface and check its ends. Ends of the blade must be slightly lower than the center, and the cutting edge must be lower than the heel of the blade. This blade will produce good quality of cut and require minimal power from the engine. By contrast, a blade that is higher at the ends than the center, or the cutting edge higher than the heel of the blade is warped or bent and must be replaced.
5. To install the blade, assemble parts in reverse order, and make sure the blade sail is facing up. Tighten special screw 102 to 136 Nm.

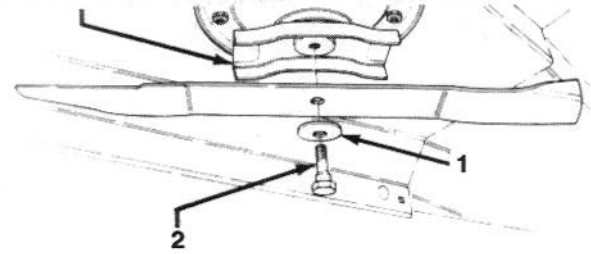

Figure 13

1. Special screw
2. Belleville washer

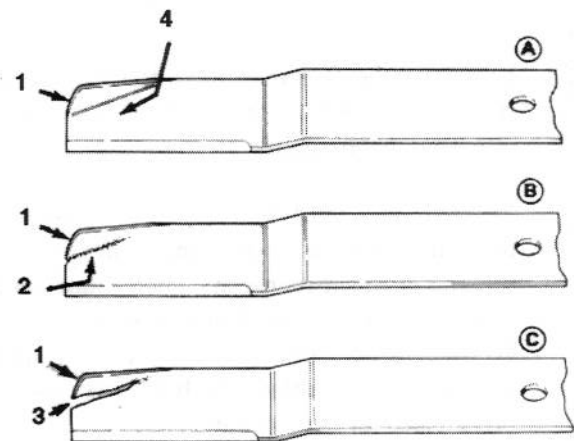

Figure 14

1. Sail
2. Wear
3. Slot formed
4. Flat part of blade

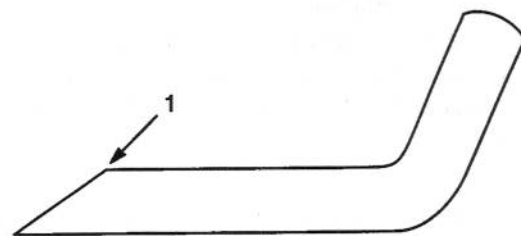

Figure 15

1. Sharpen at original angle

CHECKING AND CORRECTING MISMATCH OF BLADES

If there is mismatch between the blades, the grass will appear streaked when it is cut. This problem can be corrected by making sure the blades are straight and all blades are cutting on the same plane.

1. Using a 1-meter long carpenter's level, find a flat surface on the shop floor.
2. Set the rear caster wheels in the upper hole of the caster forks and adjust the height of cut so all six height-of-cut spacers are below the caster arm.
3. Lower the cutting unit onto a flat surface. Remove the covers from the top of the cutting unit. Loosen the idler pulleys to release tension against all three belts.
4. Rotate blades until the ends face forward and backward. Measure from the floor to the front tip of the cutting edge and remember this dimension. Then rotate same blade so its opposite end is forward and measure again. The difference between dimensions must not exceed 3 mm. If the difference exceeds 3 mm, replace the blade because it is bent. Make sure to measure all three blades.
5. Compare measurements of outer blades with the center blade. Center blade must not be more than 10 mm lower than outer blades. If center blade is more than 10 mm lower than outer blades, go to step 7 and add shims between the spindle housing and the bottom of the cutting unit.
6. Rotate the blades so the tips line up with one another. Tips of the adjacent blades must be within 3 mm of each other. If tips are not within 3 mm of each other, go to step 7 and add shims between the spindle housing and the bottom of the cutting unit.
7. Remove the capscrews, flatwashers, lockwashers and nuts from outer spindle, in the area where shims must be added. To raise or lower the blade, add a shim, Part No. 3256-24, between the spindle housing and the bottom of the cutting unit. Continue to check the blade alignment and add shims until the tips of blades are within the required dimension.

IMPORTANT: Do not use more than three shims at any one hole location. Use decreasing numbers of shims in adjacent holes if more than one shim is added to any one

hole location.

8. Tension the idler pulleys against all three belts. Also install the covers to the top of the cutting unit.
9. Set the rear caster wheels in the lower holes in the caster forks if height-of-cut is above 25 mm and adjust height of cut.
10. Mount the cutting unit to the traction unit: refer to *Mounting Cutting Unit To The Traction Unit*.

IDENTIFICATION AND ORDERING

MODEL AND SERIAL NUMBERS

The cutting unit has two identification numbers: a model number and a serial number. These numbers are stamped into a plate. The cutting unit identification plate is located just ahead of the left rear caster wheel (Fig. 16). In any correspondence concerning the cutting unit, supply the model and serial numbers to assure correct information and replacement parts are obtained.

To order replacement parts from an authorized TORO Distributor, supply the following information:

1. Model and serial numbers of the cutting unit.
2. Part number, description and quantity of parts desired.

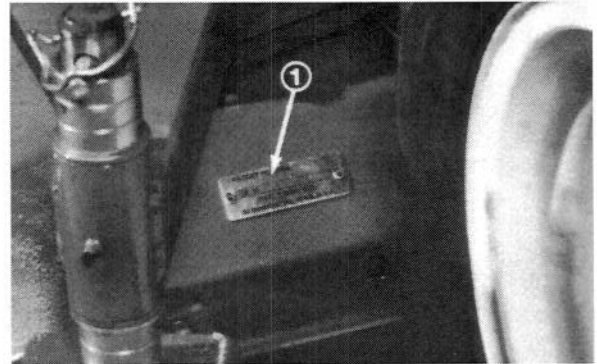

Figure 16

1. Cutting unit model and serial number

SERVICE INTERVALS

| | |
|---------------------------------------|-----------|
| Lubricate Caster Arm Bushings | Daily |
| Lubricate Caster Wheel Bearings | Daily |
| Tighten Castor Wheel Nuts | Daily |
| (Tighten after 2 & 10 hrs. initially) | 50 hours |
| Torque Blade Bolts | 50 hours |
| (Tighten after 10 hrs. initially) | 50 hours |
| Lubricate Grease Fittings | 50 hours |
| Clean The cutting Unit | 50 hours |
| Check Blade Drive Belts | 50 hours |
| Check Gear Box Oil | 50 hours |
| Change Gear Box Oil | 250 hours |

