

FORM NO. 3317-415 UK



MODEL NO. 30233—50001 & UP
MODEL NO. 30243—50001 & UP

**OPERATOR'S
MANUAL**

GROUNDMASTER® 223D
2-Wheel and 4-Wheel Drive Traction Units



To assure maximum safety, optimum performance, and to gain knowledge of the product, it is essential that you or any other operator of the mower read and understand the contents of this manual before the engine is ever started. Pay particular attention to the SAFETY INSTRUCTIONS highlighted by this symbol:



The safety alert symbol means CAUTION, WARNING or DANGER—personal safety instruction. Failure to comply with the instruction may result in personal injury.

FOREWORD

The GROUNDSMASTER 223-D was developed to satisfy the demand for a maneuverable, intermediate size, turf maintenance rotary mower. The machine has advanced concepts in engineering, design and safety; and if maintained properly, it will give excellent service.

Since the GROUNDSMASTER 223-D is a high quality product, Toro is concerned about the future use of the machine and the safety of the user. Read this manual to familiarize yourself with the proper set up, operation, and maintenance instructions.

Certain information in this manual is emphasized. DANGER, WARNING and CAUTION identify personal safety related information. IMPORTANT identifies mechanical information demanding special attention. Be sure to read the directive because it deals with the possibility of damaging a part or parts of the machine. NOTE identifies general information worthy of special attention.

If help concerning set up, operation, maintenance or safety is ever needed, contact a local Authorized Toro Distributor. In addition to genuine Toro replacement parts, the distributor also has optional equipment from the complete line of Toro turf care equipment. Keep your Toro all Toro – buy genuine Toro replacement parts and accessories.

Whenever you have questions or need service, contact

your local authorized Toro Distributor. In addition to having a complete line of accessories and professional turf care service technicians, the distributor has a complete line of genuine TORO replacement parts to keep your machine operating properly. Keep your TORO all TORO. Buy genuine TORO parts and accessories.

TABLE OF CONTENTS

| | |
|----------------------------------|----|
| SAFETY INSTRUCTIONS | 3 |
| SPECIFICATIONS | 9 |
| BEFORE OPERATING | 11 |
| CONTROLS | 15 |
| OPERATING INSTRUCTIONS | 17 |
| LUBRICATION | 20 |
| QUICK REFERENCE AID | 22 |
| PREPARATION FOR SEASONAL STORAGE | 23 |
| PRODUCT IDENTIFICATION | 23 |

Safety

Training

1. Read the instructions carefully. Be familiar with the controls and the proper use of the equipment.
2. Never allow children or people unfamiliar with these instructions to use the lawnmower. Local regulations may restrict the age of the operator.
3. Never mow while people, especially children, or pets are nearby.
4. Keep in mind that the operator or user is responsible for accidents or hazards occurring to other people or their property.
5. Do not carry passengers.
6. All drivers should seek and obtain professional and practical instruction. Such instruction should emphasize:
 - the need for care and concentration when working with rideon machines;
 - control of a ride on machine sliding on a slope will not be regained by the application of the brake. The main reasons for loss of control are:
 - insufficient wheel grip;
 - being driven too fast;
 - inadequate braking;
 - the type of machine is unsuitable for its task;
 - lack of awareness of the effects of ground conditions, especially slopes;

Preparation

1. While mowing, always wear substantial footwear and long trousers. Do not operate the equipment when barefoot or wearing open sandals.
2. Thoroughly inspect the area where the equipment is to be used and remove all objects which may

be thrown by the machine.

3. **WARNING—Petrol is highly flammable.**
 - Store fuel in containers specifically designed for this purpose.
 - Refuel outdoors only and do not smoke while refueling.
 - Add fuel before starting the engine. Never remove the cap of the fuel tank or add petrol while the engine is running or when the engine is hot.
 - If petrol is spilled, do not attempt to start the engine but move the machine away from the area of spillage and avoid creating any source of ignition until petrol vapors have dissipated.
 - Replace all fuel tanks and container caps securely.
4. Replace faulty silencers.
5. Before using, always visually inspect to see that the blades, blade bolts and cutter assembly are not worn or damaged. Replace worn or damaged blades and bolts in sets to preserve balance.
6. On multi-bladed machines, take care as rotating one blade can cause other blades to rotate.

Operation

1. Do not operate the engine in a confined space where dangerous carbon monoxide fumes can collect.
2. Mow only in daylight or in good artificial light.
3. Before attempting to start the engine, disengage all blade attachment clutches and shift into neutral.
4. Do not use on slopes of more than:
 - Never mow side hills over 5°
 - Never mow uphill over 10°
 - Never mow downhill over 15°

5. Remember there is no such thing as a “safe” slope. Travel on grass⁹ slopes requires particular care. To guard against overturning:
 - do not stop or start suddenly when going up or downhill;
 - engage clutch slowly, always keep machine in gear, especially when travelling downhill;
 - machine speeds should be kept low on slopes and during tight turns;
 - stay alert for bumps and hollows and other hidden hazards;
 - never mow across the face of the slope, unless the lawnmower is designed for this purpose.
6. Use care when pulling loads or using heavy equipment.
 - Use only approved drawbar hitch points.
 - Limit loads to those you can safely control.
 - Do not turn sharply. Use care when reversing.
 - Use counterweight(s) or wheel weights when suggested in the instruction handbook .
7. Watch out for traffic when crossing or near roadways.
8. Stop the blades rotating before crossing surfaces other than grass.
9. When using any attachments, never direct discharge of material toward bystanders nor allow anyone near the machine while in operation .
10. Never operate the lawnmower with defective guards, shields or without safety protective devices in place.
11. Do not change the engine governor settings or overspeed the engine. Operating the engine at excessive speeds may increase the hazard of personal injury.
12. Before leaving the operator's position:
 - disengage the power take-off and lower the attachments;
 - change into neutral and set the parking brake;
 - stop the engine and remove the key.
13. Disengage drive to attachments, stop the engine, and disconnect the spark plug wire(s) or remove the ignition key
 - before cleaning blockages or unclogging chute;
 - before checking, cleaning or working on the lawnmower;
 - after striking a foreign object. Inspect the lawnmower for damage and make repairs before restarting and operating the equipment;
 - if the machine starts to vibrate abnormally (check immediately).
14. Disengage drive to attachments when transporting or not in use.
15. Stop the engine and disengage drive to attachment
 - before refueling;
 - before removing the grass catcher;
 - before making height adjustment unless adjustment can be made from the operator's position.
16. Reduce the throttle setting during engine runout and, if the engine is provided with a shutoff valve, turn the fuel off at the conclusion of mowing.

Maintenance and Storage

1. Keep all nuts, bolts and screws tight to be sure the equipment is in safe working condition.
2. Never store the equipment with petrol in the tank inside a building where fumes may reach an open flame or spark.
3. Allow the engine to cool before storing in any enclosure.

4. To reduce the fire hazard, keep the engine, silencer, battery compartment and petrol storage area free of grass, leaves, or excessive grease.
5. Check the grass catcher frequently for wear or deterioration.
6. Replace worn or damaged parts for safety.
7. If the fuel tank has to be drained, this should be done outdoors
8. On multi-bladed machines, take care as rotating one blade can cause other blades to rotate.
9. When machine is to be parked, stored or left unattended, lower the cutting means unless a

Symbol Glossary

Safety alert symbol



Dismemberment—Mower in rearward position.



Safety alert symbol



Stay a safe distance from the machine.

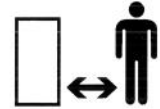

Read operator's manual



Stay a safe distance from the mower.

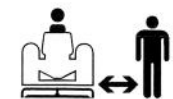

Consult technical manual for proper service procedures



Keep children a safe distance from the machine.



Thrown or flying objects—whole body exposure



Machine rollover—side hill



Thrown or flying objects—rotary side-mounted mower. Keep deflector shield in place.



Machine rollover—up hill



Severing toes or foot—mower blade



Machine rollover—down hill



Severing fingers or hand—mower blade



Machine rollover—roll over protection system













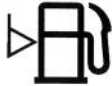













Rotating blade can cut off toes or fingers. Stay clear of blade as long as the engine is running.

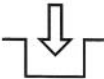

Do not open or remove safety shields while the engine is running.



| | | | |
|---------------------------------|---|----------------------------|---|
| Fast |  | Fuel |  |
| Slow |  | Fuel level |  |
| Decreasing/increasing |  | Volume empty |  |
| On/Run |  | Volume full |  |
| Off/Stop |  | Battery charging condition |  |
| Engine |  | Head lights—Main/high beam |  |
| Engine start |  | Brake system |  |
| Engine stop |  | Parking brake |  |
| Choke |  | Clutch |  |
| Engine temperature |  | PTO (Power Take Off) |  |
| Engine lubricating oil pressure |  | Engage |  |
| Engine lubricating oil pressure |  | Disengage |  |
| | | Unlock |  |
| | | Lock |  |

| | | | |
|--|--|---|---------------------------------|
| Cutting element—basic symbol | | Riding on this machine is allowed only on a passenger seat and only if the driver's view is not hindered. | |
| Cutting element—height adjustment | | Crushing of fingers or hands—force applied from the side | |
| Cutting unit—lower | | Kickback or upward motion—stored energy | |
| Cutting unit—raised | | Shut off engine and remove key before performing maintenance or repair work. | |
| Cutting or entanglement of foot—rotating auger | | Machine travel direction—combined | |
| Severing of fingers or hand—impeller blade | | Low | L H R N 1 2 3 |
| Keep a safe distance from snowthrower. | | High | |
| Stay a safe distance from snowthrower. | | Reverse | |
| Tractors must be equipped with 45 kg rear wheel wheel weight with this attachment installed. | | Neutral | |
| Machine rollover protection system snowthrower | | First gear | |
| Severing of hand—rotating knives | | Second gear | |
| Severing of foot—rotating knives | | Third gear up to a maximum number of forward gears. | |

Specifications

Engine:

Manufacturer—Mitsubishi.
Horsepower—22 (16 Kw) @ 3000 RPM.
Torque—40 ft-lb (54.2 Nm) @ 2400 RPM.
Displacement—58.1 cu in. (952 cc).
Crankcase Capacity—3.8 qt. (3.6 L).
Governor—Mechanical.
Governor Limit—3100–3250 RPM.
Idle Speed—1700 RPM.

Air Cleaner: Donaldson heavy duty with precleaner. Remote mounted.

Fuel Tank Capacity: 8.5 gal. (32 l).

Fuel Filter/Water Separator: 3-micron spin-on type element. Replaceable (Toro Part No. 63-8300).

Fuel Pump: 12-volt electric (transistor type) w/replaceable fuel filter (Toro Part No. 43-2550).

Cooling System:

Radiator—6 qt (5.7 l) capacity.
Expansion Tank—Remote mounted; 1 qt (0.946 l) capacity. System contains a 50/50 mix of ethylene glycol anti-freeze and water.

Electrical: Battery—12 volt, BCI group size 26, 530 Amp at 0° F. 35-amp alternator with regulator/rectifier.

Drive Coupling: Transmission driven by steel shaft with flexible rubber couplings at each end.

Transmission:

Manufacturer & Type—Sundstrand hydrostatic, Type U15. Normal Charge Pressure – 70–150 psi (483–1034 kPa).
Implement Relief Setting – 700–800 psi (4 826 – 5 516 kPa).

Hydraulic Filter: 25-micron mounted directly to transmission. Replaceable (Toro Part No. 23-2300).

Drive Axle: Manufacturer – Dana Corp., Model GT-20. Axle serves as a hydraulic fluid reservoir and mates directly with the transmission. Approximately 5

qt (4.7 l) capacity. 4-Wheel Drive has mechanical rear axle coupled to front axle by a drive shaft and clutch.

Brakes: Mechanical drum type, 7 in. (17.8 cm) dia. x 1-3/4 in. (45 mm) wide. Individually controlled by two pedals connected by cable and conduit for steering assist. Pedals may be latched together for two wheel braking. Lever provided for the parking brake.

Tires, Wheels, Pressure:

Front Tires—23 x 8.50 - 12
Rear Tires—16 x 6.50 - 8
All tires 4 ply rating, tubeless type.
Pressure—20 psi (138 kPa).

Steering: 13 in. (33 cm) steering wheel. TRW power steering valve.

Main Frame: Frame is welded, formed steel.

Instrumentation: Fuel gauge, water temperature gauge, hour meter and warning lights for high temperature shutdown, oil pressure, amperage and glow plug are mounted on the console.

Controls: Throttle, PTO switch, parking brake, implement lift, ignition switch and glow plug switch are all hand-operated. Forward/reverse traction pedal and turning brakes are foot operated.

PTO Drive: PTO shaft is clutched by a torque-teamed HA Section, spring tensioned V-belt directly from the engine output shaft. PTO shaft engaged by electric clutch/brake assembly. PTO speed – 2200 RPM @ 3250 RPM engine speed.

Implement Connection—Universal joint and telescoping shaft assembly.

Lift Cylinders: Two, with 2 in. (51 mm) bore, 3.5 in. (89 mm) stroke.

Interlock Switches: Prevents engine starting if traction pedal or PTO switch are engaged. Stops the engine if operator leaves seat with either traction pedal or PTO switch engaged.

Dimensions and Weight:

| | |
|------------------------|------------------|
| Length: | 208 cm (82 in.) |
| Width (2-Wheel drive): | 111 cm (44 in.) |
| (4-Wheel drive): | 119 cm (47 in) |
| Height: | 127 cm (50 in.) |
| Weight: | 418 kg (1120 lb) |

Before Operating

CHECK THE ENGINE OIL

The engine is shipped with 3.8 qt (3.6 l) of oil in the crankcase; however, check the oil level before and after you first start the engine.

1. Position the machine on a level surface.
2. Open the hood.
3. Remove the dipstick and wipe it with a clean rag. Insert the dipstick into the tube and make sure it is seated fully. Remove the dipstick and check the level of oil (Fig. 1). If the oil level is low, add enough oil to raise the level to the FULL mark on the dipstick. Do not overfill (Fig. 2).

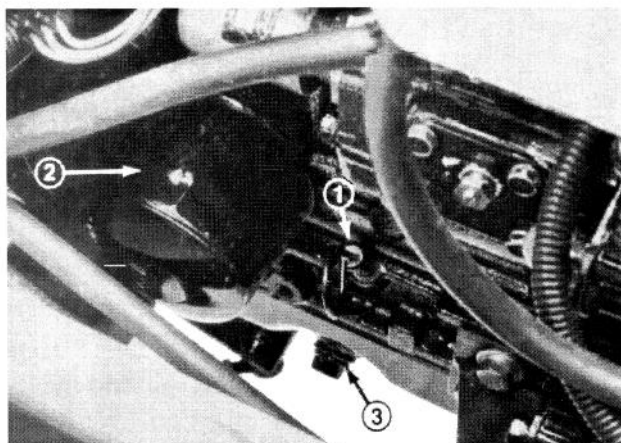

Figure 1

1. Engine oil dipstick
2. Engine oil filter
3. Oil drain plug

Note: If the level of oil is at the ADD mark on the dipstick, add 1 pint (0.47 l) of oil and recheck the level. Do not overfill.

4. The engine uses any high-quality 10W30 detergent oil having the American Petroleum Institute – API – “service classification” CD.

IMPORTANT: Check the level of oil every 5 operating hours or daily. Change oil after every 50 hours of operation.

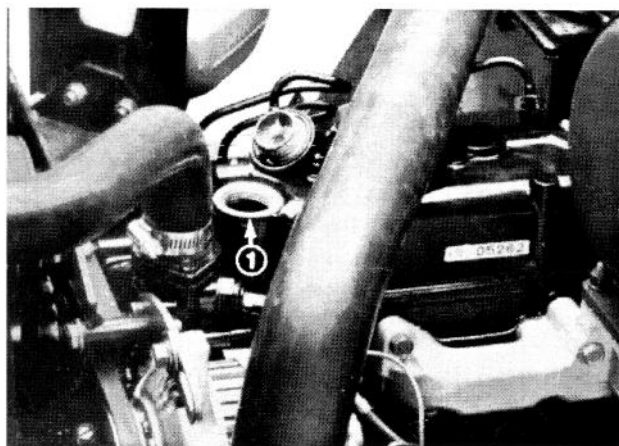

Figure 2

1. Engine oil fill

5. Insert the dipstick into the tube.

CHECK COOLING SYSTEM

Clean debris off screen and front of radiator daily (Fig. 3), hourly if conditions are extremely dusty and dirty.

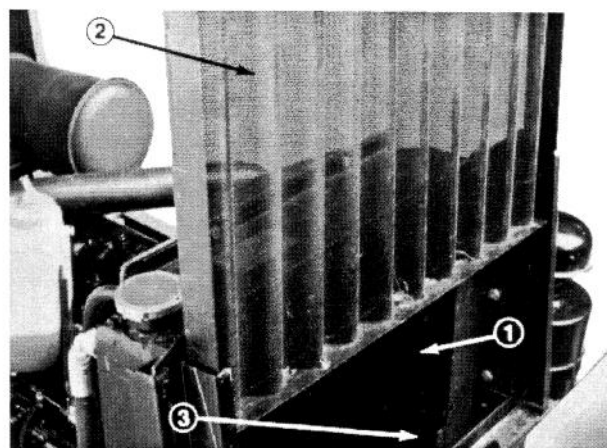

Figure 3

1. Radiator
2. Radiator screen
3. Screen channel

The cooling system is filled with a 50/50 solution of water and permanent ethylene glycol anti-freeze. Check the level of coolant at the beginning of each day (Fig. 4) before starting the engine. Capacity of the

cooling system is 6 quarts (5.7 l).

1. Carefully remove the radiator cap and the expansion tank cap.

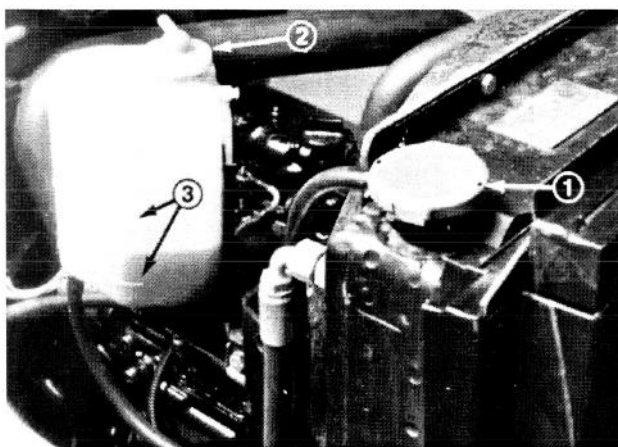
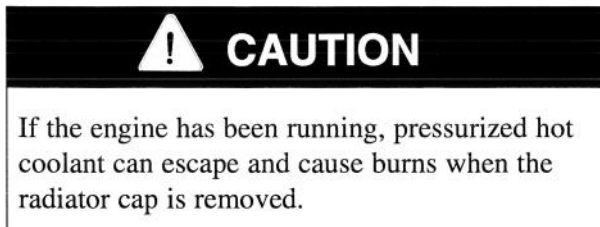

Figure 4

1. Radiator cap
2. Expansion tank cap
3. Expansion tank fill marks

2. Check the level of coolant in the radiator. The radiator should be filled to the top of the filler neck and the expansion tank filled to between the marks on its side.
3. If the coolant level is low, replenish the system. **DO NOT OVERFILL.**
4. Install the radiator and expansion tank caps.

CHECK HYDRAULIC SYSTEM FLUID

The hydraulic system was designed to operate on any high quality detergent oil having the American Petroleum Institute-API-“service classification” SF, CC or CD. Oil viscosity—weight—must be selected

according to anticipated ambient temperature. Temperature/viscosity recommendations are:

| Expected Ambient Temperature | Recommended Viscosity and type |
|------------------------------|---|
| Over 32°C | SAE 30, Type SF, CC or CD |
| 4–38° C | SAE 10W-30 or 10W40 Type SF, CC or CD |
| -1–10° C | SAE 5W30, Type SF, CC or CD |
| Below -1° C | Type “F” or “FA” Automatic Transmission Fluid |

Note: Do not mix engine oil and automatic transmission fluid or hydraulic component damage may result. When changing fluids, also change transmission filter. **DO NOT USE DEXRON II ATF.**

The axle housing acts as the reservoir for the system. The transmission and axle housing are shipped from the factory with approximately 5 quarts (4.7 l) of SAE 10W–30 engine oil. However, check the level of transmission oil before the engine is first started and daily thereafter.

1. Position the machine on a level surface. Place all controls in their neutral position and start the engine. Run the engine at lowest possible RPM to purge the system of air. **DO NOT ENGAGE THE PTO.** Turn the steering wheel several times fully to the left and right. Raise the cutting unit to extend the lift cylinders, aiming steering wheels straight forward and stop the engine.
2. Remove the dipstick cap (Fig. 5) from filler neck and wipe it with a clean cloth. Screw the dipstick cap finger-tight onto filler neck; then remove it and check the level of fluid. If the level is not within 1/2 inch (13 mm) from the groove in the dipstick (Fig. 5), add SAE 10W–30 engine oil, or, if used, automatic transmission fluid to raise the level to groove mark. Do not overfill.

IMPORTANT: When adding transmission fluid to the hydraulic system, use a funnel with

a fine wire screen—200 mesh or finer—and make sure funnel and transmission fluid are immaculately clean. This procedure prevents accidental contamination of the hydraulic system.

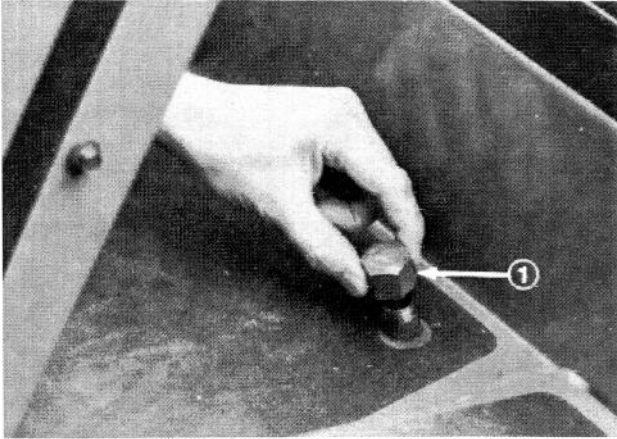

Figure 5

1. Hydraulic system reservoir fluid/add dipstick cap
3. Thread the dipstick fill cap finger-tight onto filler neck. It is not necessary to tighten cap with a wrench.
4. Check all hoses and fittings for leaks.

FILL FUEL TANK

The engine runs on No. 2-D or 1-D automotive type diesel fuel with a minimum cetane rating of 40.

Note; Higher cetane rated fuel may be required if the machine is to be used at high altitude and low-atmospheric temperatures.

Use No. 2-D diesel fuel at temperatures above 20° F (–7° C), and No. 1-D diesel fuel below 20° F (–7° C). Use of No. 1-D diesel fuel at lower temperatures provides lower flash point and pour point characteristics, therefore easing startability and lessening chances of chemical separation of the fuel due to low temperatures (wax appearance, which may plug filters).

Use of No. 2-D diesel fuel above 20° F (–7° C) will contribute toward longer life of the pump components. Do not use furnace oil.

DANGER

Because diesel fuel is flammable, use caution when storing or handling it. Do not fill the fuel tank while the engine is running, hot or when the machine is in an enclosed area. Vapors may build up and be ignited by a spark or flame source many feet away. **DO NOT SMOKE** while filling the fuel tank to prevent the possibility of an explosion. Always fill the fuel tank outdoors and wipe up any spilled diesel fuel before starting the engine. Use a funnel or spout to prevent spilling diesel fuel and fill the tank to about 25 mm below the filler neck. Store diesel fuel in a clean, safety-approved container and keep the cap in place on the container. Keep diesel in a cool, well-ventilated place; never in an enclosed area such as a hot storage shed. To assure volatility and to prevent contamination, do not buy more than a 6-month supply.

Store fuel outside of buildings in a convenient location. Tipping the front of the tank up slightly will allow contaminants to collect at the lower end away from the outlet. Never empty the tank below 4 in. (10 cm) from the bottom of the tank to avoid picking up water and other contaminants that may have collected at the bottom. Either filter the remainder at the bottom through a chamois or dispose of it periodically to prevent excessive build-up of contaminants.

Keep all fuel containers free of dirt, water, scale and other contaminants. Many engine difficulties can be traced to contaminants in the fuel.

Use only metal containers for fuel storage. **DO NOT** store the fuel in a galvanized metal container. A chemical reaction will result, which will plug the filters and cause possible fuel system damage.

If possible, fill the fuel tank at the end of each day. This will prevent possible buildup of condensation inside the fuel tank, preventing possible engine damage. Allow the engine to thoroughly cool down before refueling.

1. Using a clean cloth, clean the area around the fuel tank cap.
2. Remove cap from the fuel tank (Fig. 6) and fill the 8 gallon (34 l) tank to within 1 inch (25 mm) from the top with diesel fuel. Install fuel tank cap tightly after filling tank.

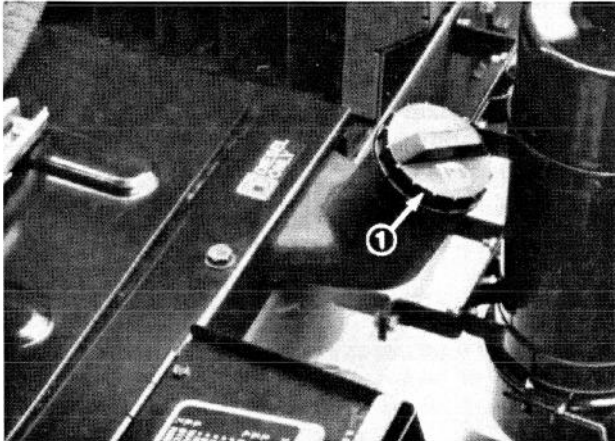

Figure 6

1. Fuel tank cap

4. To make sure that the cavities at each end of the axle tube are filled, jack up each side of the axle 6 inches. Then with the axle level, check the level at the center plug hole.

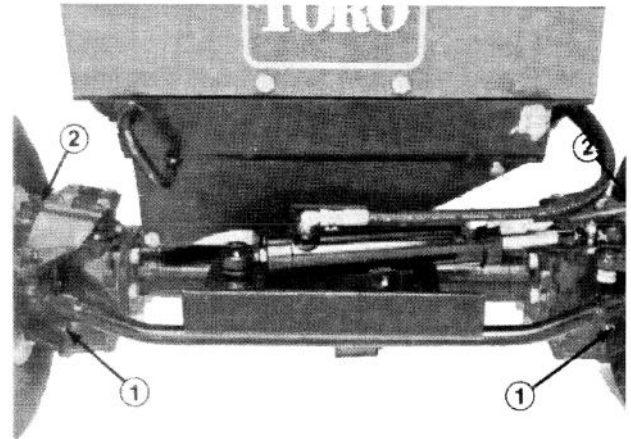

Figure 7

1. Check plugs (2)
2. Mounting bolts

Four-Wheel Drive Models Only: Check Rear Axle Lubricant

The rear axle has three separate reservoirs which use SAE 80W-90 gear lub. Although the axle is shipped with lubricant from the factory, check the level before operating the machine.

1. Position the machine on a level surface.
2. Remove a check plug from each end of the axle and make sure lubricant is up to the bottom of the hole. If the level is low, remove one of the mounting bolts above each end plug and add enough lubricant to bring the level up to the bottom of the hole (Fig. 7).
3. Remove the plug in the center of the axle and check the level. If the level is low, add enough lubricant to bring the level up to the bottom of the hole.

Controls

Service Brakes (Fig. 8)—The left and right brake pedals are connected to the left and right front wheels. Since both brakes work independently of each other, the brakes can be used to turn sharply or to increase traction if one wheel tends to slip while operating on certain slope conditions. However, wet grass or soft turf could be damaged when the brakes are used to turn sharply. To make a “quick-stop”, depress both brake pedals together. Always lock the brakes together when transporting the traction unit.

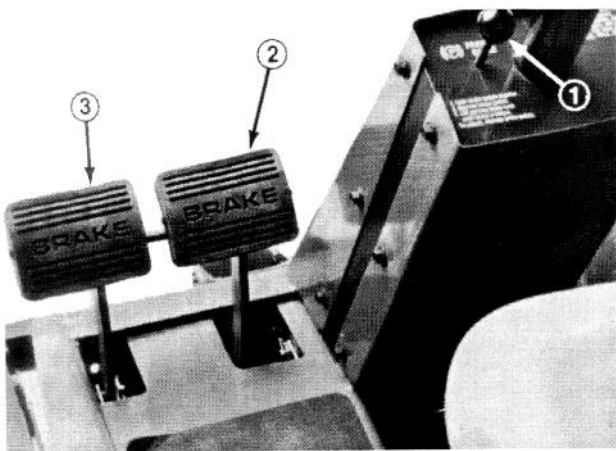

Figure 8

1. Parking brake knob
2. Right brake pedal
3. Left brake pedal

Parking Brake—Whenever the engine is shut off, the parking brake must be engaged to prevent accidental movement. To engage the parking brake, push lock arm (Fig. 9) on left brake pedal so that it locks together with the right pedal. Next, push down fully on both pedals and pull the parking brake knob out (Fig. 8) then release the pedals. To release the parking brake, depress both pedals until the parking brake knob retracts. Before starting the engine, however, the lock arm may be disengaged from the left brake pedal so both pedals work independently with each front wheel.

Amp Light (Fig. 10)—The amp light should be off when the engine is running. If it is on, the charging system should be checked and repaired if necessary.

Hour Meter (Fig. 10)—Accumulated engine operating time registers on the hour meter.

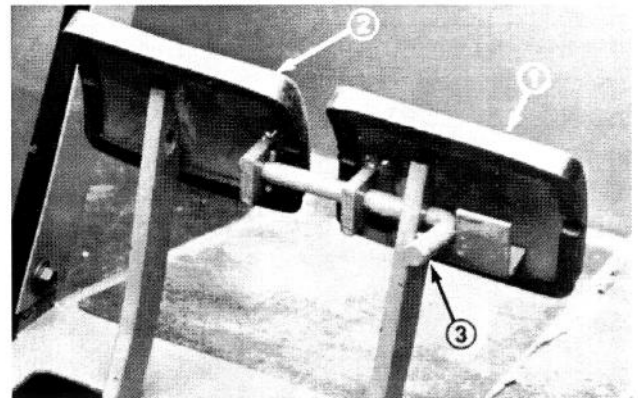

Figure 9

1. Left brake pedal
2. Right brake pedal
3. Lock arm

Temperature Gauge and High Temperature Light (Fig. 10)—The coolant temperature gauge registers the coolant temperature in the system. If the temperature gets too high, the engine will automatically shut off and the High Temperature shutoff light will light. When this happens, turn the ignition key off, check the radiator for debris, check the fan belt and check the expansion tank for proper coolant level. The high temperature shutoff will automatically reset when the coolant temperature has reached a safe level.

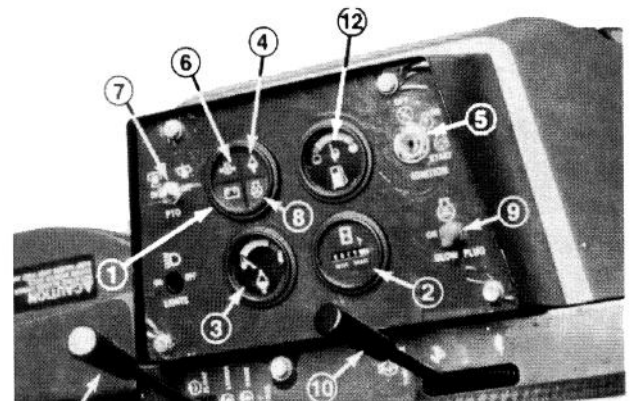

Figure 10

1. Left brake pedal
2. Right brake pedal
3. Lock arm
4. High temperature shutoff light
5. Ignition key switch
6. Oil pressure light
7. PTO switch
8. Glow plug indicator
9. Glow plug switch
10. Throttle
11. Hydraulic lift lever
12. Fuel gauge

Low Oil Pressure Light (Fig. 10)—If engine oil pressure falls below a safe level, the light glows. Stop the engine and repair before resuming operation.

PTO Switch (Fig. 10)—Pull up on the sleeve on the toggle switch handle and move the handle to ON to ENGAGE electric PTO clutch. Pull up on the sleeve and move the handle to OFF to DISENGAGE electric PTO clutch. The only time the PTO switch should be in the ENGAGE position is when the implement is down in operating position and ready to begin operation.

Ignition Key Switch (Fig. 10)—The ignition switch, which is used to start and stop the engine, has three positions: OFF, RUN and START. Turn the key clockwise—START position—to engage the starter motor. Release the key when the engine starts. The key will move automatically to the ON position. To shut the engine off, turn the key counterclockwise to the OFF position.

Glow Plug Switch and Indicator (Fig. 10)—Use to preheat the engine cylinders prior to cold engine starting procedures—cylinders are preheated automatically during warm engine start operation. For cold starting, push the switch lever upward and hold while viewing the indicator. The indicator will glow orange when the glow plugs are activated. Length of time necessary to preheat cylinders should be determined by atmospheric temperature.

Throttle (Fig. 10)—The throttle is used to operate the engine at various speeds. Moving the throttle forward increases engine speed—FAST; rearward decreases engine speed—SLOW. The throttle controls the speed of the cutter blades and, together with traction pedal, controls the ground speed of the traction unit.

Hydraulic Lift Lever (Fig. 10)—The hydraulic lift lever has three positions: FLOAT, TRANSPORT and RAISE. To lower the cutting unit to the ground, move the lift lever forward into the notch FLOAT. The FLOAT position is used for mowing and when the machine is not in operation. To raise the cutting unit, pull the lift lever rearward to the RAISE position. After the cutting unit is raised, allow the lift lever to move to the TRANSPORT position. The cutting unit must be raised when driving from one work area to

another.

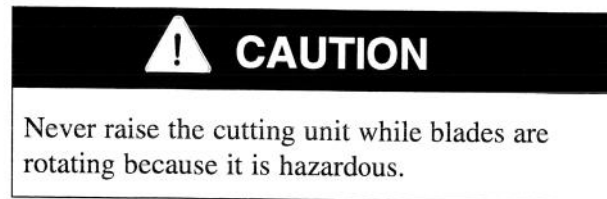

Traction Pedal (Fig. 11)—The traction pedal has two functions: one is to make the machine move forward, the other is to make it move rearward. Using the heel and toe of the right foot, depress the top of the pedal to move forward and the bottom of the pedal to move rearward. Ground speed is proportionate to how far pedal is depressed. For maximum ground speed, the traction pedal must be fully depressed while the throttle is in the FAST position. Maximum speed forward is 10 mph (16 Km/hour). To get maximum power under heavy load or when ascending a hill, have the throttle in the FAST position while depressing the traction pedal slightly to keep engine rpm high. When engine rpm begins to decrease, release the traction pedal slightly to allow rpm to increase.

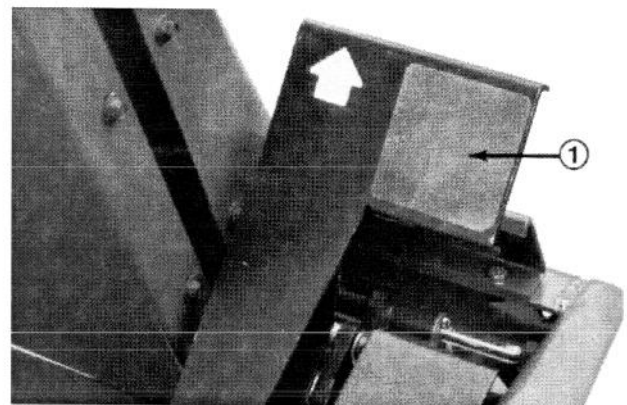

Figure 11

1. Traction pedal

Seat Adjusting Handle—To adjust the seat, loosen the adjusting knobs and slide the seat to the desired position. Tighten the knobs to lock the seat in place.

Seat Adjusting Handle—Deluxe Seat—To adjust the seat, move the lever on left side outward, slide the seat to the desired position and release the lever so it will lock in track.

Operation

STARTING/STOPPING THE ENGINE

IMPORTANT: The fuel system must be bled if any of the following situations have occurred.

- A. Initial start up of a new machine.
- B. The engine has ceased running due to lack of fuel.
- C. Maintenance has been performed upon fuel system components; i.e., filter replaced, separator serviced, etc.

Refer to Bleeding The Fuel System.

1. Ensure the parking brake is set, the PTO switch is in OFF and the lift lever is in the TRANSPORT or FLOAT position (Fig. 9). Remove your foot from the traction pedal and make sure it is in neutral.
2. Move the throttle control (Fig. 9) to the full FAST position.
3. When temperature is below 15°C (60° F), push glow plug switch to ON (Fig. 9) and hold for the suggested interval.

Note: Do not exceed 1 minute of continuous use or glow plug may burn out prematurely.

Note: Refer to chart indicating approximate pre-heat time suggested in various temperature ranges.

| Temperature | Preheat time (sec) |
|----------------|--------------------|
| Above 5° C | 10 |
| +5° C to -5° C | 20 |
| Below -5° C | 30 |

4. Turn the key in ignition switch to START position (Fig.). Release the key immediately when the engine starts and allow it to return to RUN position. Move the throttle control to the SLOW position.

Note: Do not run the starter motor more than 20 seconds at a time or premature starter failure may result. If the engine fails to start after 20 seconds, turn the key to OFF, recheck the controls and procedures, wait 10 additional seconds and repeat the starter operation.



CAUTION

Shut the engine off and wait for all moving parts to stop before checking for oil leaks, loose parts or other malfunctions.

5. When the engine is started for the first time, or after the engine oil change or overhaul of the engine, transmission or axle, operate the machine in forward and reverse for one to two minutes. Also operate the lift lever and PTO lever to assure proper operation of all parts. Turn the power steering wheel to the left and right to check steering response. Then shut the engine off and check fluid levels, check for oil leaks, loose parts and any other noticeable malfunctions.
6. To stop the engine, move the throttle control backward to SLOW, move the PTO switch to OFF and turn the ignition key to OFF. Remove the key from the switch to prevent accidental starting.

BLEEDING THE FUEL SYSTEM

1. Raise the hood over the engine.
2. Loosen the air bleed screw on top of the fuel filter/water separator (Fig. 12).
3. Turn the ignition key switch to RUN. The electric fuel pump will begin operation, thereby forcing air out around air bleed screw. Leave the key in the RUN position until a solid stream of fuel flows out around screw. Tighten the screw and turn the key to OFF.

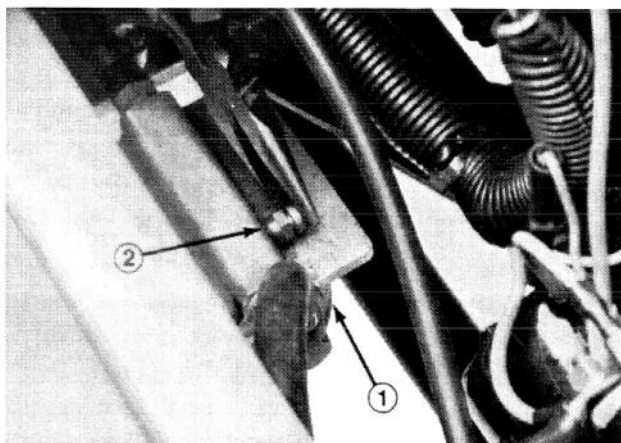

Figure 12

- 1. Fuel filter
- 2. Air bleeder screw

4. Open the air bleed screw on the fuel injection pump (Fig. 13) with a 10 mm wrench.

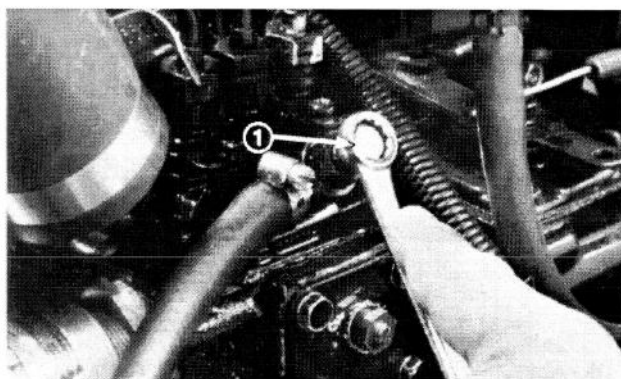

Figure 13

- 1. Fuel injection pump bleeder

5. Turn the key to the RUN position. The electric fuel pump will begin operation, thereby forcing air out around air bleed screw on fuel injection pump. Leave the key in the RUN position until solid stream of fuel flows out around the screw. Tighten the screw and turn the key to OFF.

CHECKING THE INTERLOCK SAFETY SYSTEM

The purpose of the safety interlock system is to prevent the engine from cranking or starting unless the traction pedal is in neutral and the PTO switch is in

the OFF position. Also, the engine will stop when the PTO control is engaged or the traction pedal is depressed with the operator off the seat.

! CAUTION

Do not disconnect the safety switches because they are for the operator's protection. Check operation of the switches daily to be sure the interlock system is operating correctly. If a switch is malfunctioning, replace it before operating the machine. Replace the switches every two years to be sure of maximum safety.

1. Move the PTO switch to OFF and remove your foot from the traction pedal so it is fully released.
2. Turn the key to START. The engine should crank. If the engine cranks, go to step 3. If the engine does not crank, there may be a malfunction in the interlock system.
3. Rise from the seat and engage the PTO switch while the engine is running. The engine should stop within 2 seconds. If the engine stops, the switch is operating correctly; thus, go to step 4. If the engine does not stop, there is a malfunction in the interlock system.
4. Rise from the seat and depress the traction pedal while the engine is running and the PTO lever is disengaged. The engine should stop within 2 seconds. If the engine stops, the switch is operating correctly; thus, continue operation. If the engine does not stop, there is a malfunction in the interlock system.

OPERATING CHARACTERISTICS

Practice driving the GROUNDMASTER® 223-D before initial operation because it has a hydrostatic transmission and its characteristics are different than some turf maintenance machines. Some points to consider when operating the traction unit and cutting unit are the transmission, engine speed, load on the cutting

blades, and the importance of the brakes.

! CAUTION

Adequate rear weight is necessary to prevent the rear wheels from leaving the ground. Do not stop suddenly while cutting unit or implement is raised. Do not travel down hill with the cutting unit or implement raised. If the rear wheels leave the ground, steering is lost.

To maintain enough power for the traction unit and cutting unit while mowing, regulate traction pedal to keep engine rpm high and somewhat constant. A good rule to follow is: decrease ground speed as the load on the cutting blades increases; and increase ground speed as the load on the blades decreases. This allows the engine, working with the transmission, to sense the proper ground speed while maintaining the high blade tip speed necessary for good quality of cut. Therefore, let the traction pedal to move upward as engine speed decreases, and depress the pedal slowly as speed increases. By comparison, when driving from one work area to another—with no load and cutting unit raised—have the throttle in the FAST position and depress the traction pedal slowly but fully to attain maximum ground speed.

CAUTION: This product may exceed noise levels of 85 dB(A) at the operator position. Ear protectors are recommended for prolonged exposure to reduce the potential of permanent hearing damage.

Another characteristic to consider is the operation of the brakes. The brakes can be used to assist in turning the machine; however, use them carefully, especially on soft or wet grass because the turf may be torn accidentally. The brakes can be used to great advantage to control the direction of the cutting unit when trimming along fences or similar objects. Another benefit of the brakes is to maintain traction. For example; in some slope conditions, the uphill wheel slips and loses traction. If this situation occurs, depress the uphill brake pedal gradually and intermittently until the uphill wheel stops slipping, thereby increasing traction on the downhill wheel. If independent braking is not desired, engage the lever on the left brake pedal with right pedal. This provides simultaneous braking at both wheels.

Before stopping the engine, disengage all controls and move the throttle to SLOW. Moving the throttle to SLOW reduces high engine speed, noise and vibration. Turn the ignition key to OFF to stop the engine.

PUSHING OR TOWING THE TRACTION UNIT

In an emergency, the traction unit can be pushed or towed for a very short distance. However, Toro does not recommend this as standard procedure.

IMPORTANT: Do not push or tow the traction unit faster than 2 to 3 mph (3.2 to 4.8 Km/hour) because transmission may be damaged. If the traction unit must be moved a considerable distance, transport it on a truck or trailer. Whenever the traction unit is pushed or towed, the by-pass valve must be open.

1. Remove the hair pin and pivot the seat platform forward and locate seat support rod in the detent notch.
2. Depress and hold the pins located in the center of the two (2) check valve assemblies in the top of the transmission (Fig. 14) while pushing or towing the machine.

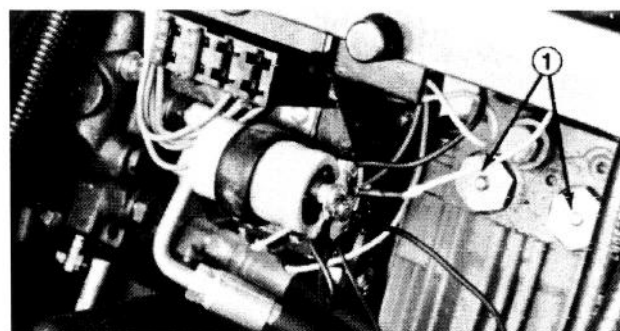

Figure 14

1. Transmission check valve bypass pins (2)
3. Start the engine momentarily after repairs are completed and make sure the pins are in the fully disengaged (fully up) position.

IMPORTANT: Running the machine with by-pass valve open will cause the transmission to overheat.

Maintenance

LUBRICATION

GREASING BEARINGS AND BUSHINGS

The traction unit has grease fittings that must be lubricated regularly with No. 2 General Purpose Lithium Base Grease. If the machine is operated under normal conditions, lubricate all bearings and bushings after every 50 hours of operation or immediately after every washing. Bearings and bushings must be lubricated daily when operating conditions are extremely dusty and dirty. Dusty and dirty operating conditions could cause dirt to get into the bearings and bushings, resulting in accelerated wear.

Apply a liberal coating of grease to the check valve pins once each year (Fig. 14). The traction unit has bearings and bushings that must be lubricated, and these lubrication points are shown in the following figures.

1. Wipe grease fitting clean so foreign matter cannot be forced into the bearing or bushing.
2. Pump grease into the bearing or bushing.
3. Wipe up excess grease.

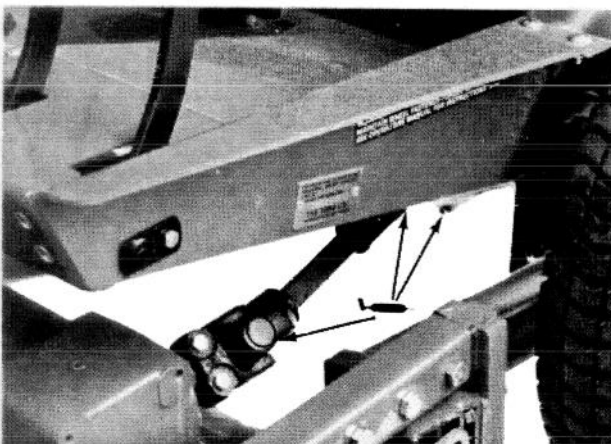

Figure 15

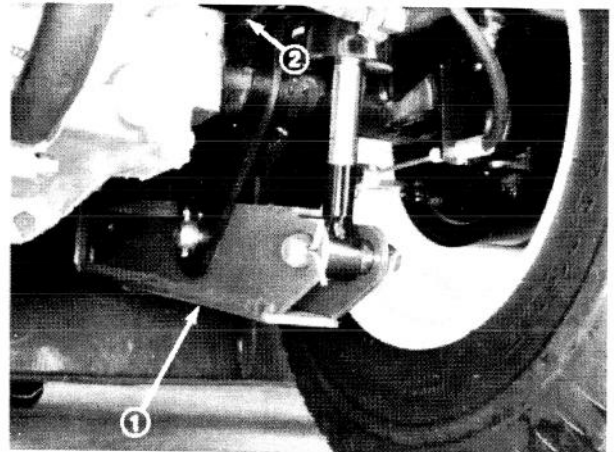

Figure 16

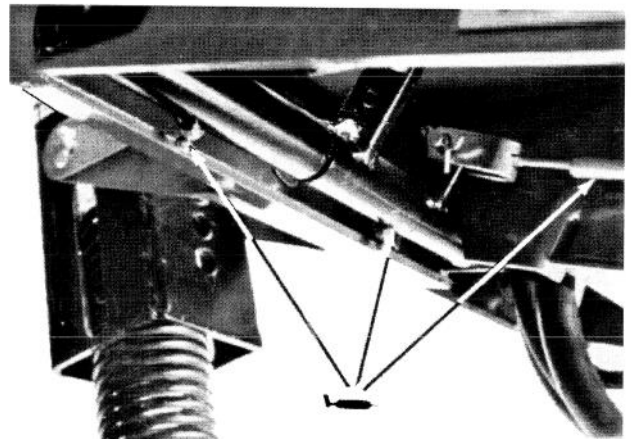

Figure 17

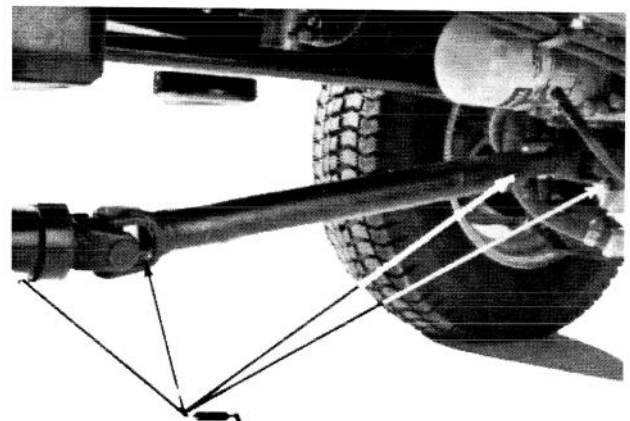

Figure 18 (Four-Wheel Drive)



Figure 19

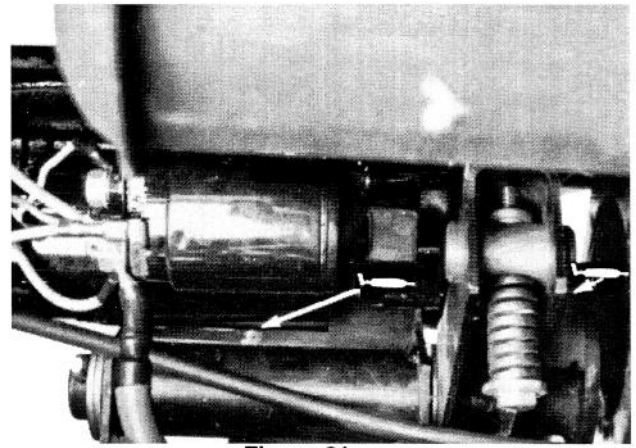

Figure 21

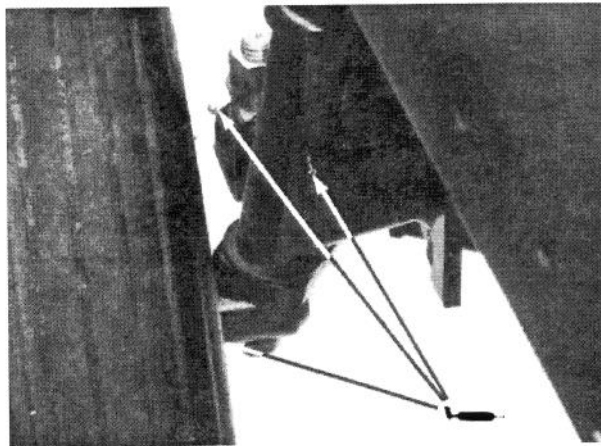

Figure 20 (2-Wheel Drive only)

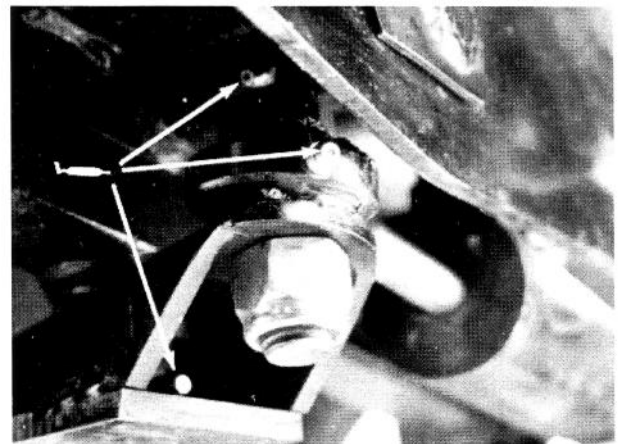
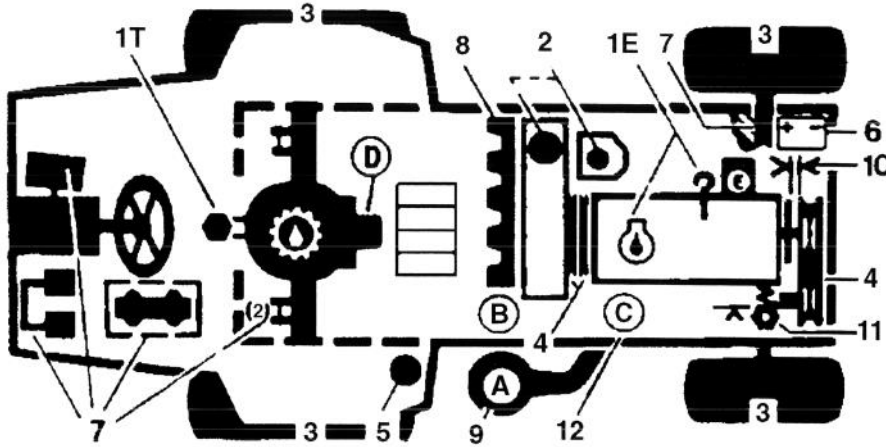

Figure 22 (2-Wheel Drive only)

Quick Reference



1. Oil levels
2. Coolant level
3. Tire Pressure
4. Belts
5. Fuel—Diesel Only
6. Battery
7. Grease, Lube points
8. Radiator screen
9. Air cleaner
10. Electric clutch gap
11. PTO belt tension
12. Water separator

| Filters | Part No. |
|------------------|----------|
| Air | 277110 |
| Fuel pump | 43-2550 |
| Fuel line | 63-8300 |
| Transmission oil | 23-2300 |
| Engine oil | 67-4330 |

| Fluids | Change Intervals | | Capacity | Change Intervals | |
|------------|--------------------------------------|---------------|----------|------------------|-----------|
| | >0° C | <0° C | | Fluid | Filter |
| Engine oil | SAE 30 CD | SAE 10W-30 CD | 3.6 l | 50 hours | 100 hours |
| Fuel | No. 2-D | No. 1-D | 34 l | ----- | 400 hours |
| Coolant | 50/50 mix Ethylene glycol antifreeze | | 6 l | 2 years | |

Preparation for Seasonal Storage

Traction Unit

1. Thoroughly clean the traction unit, cutting unit and the engine, paying special attention to these areas:
 - radiator and radiator screen
 - underneath the cutting unit
 - under the cutting unit belt covers
 - counterbalance springs
 - P.T.O. Shaft Assembly
 - all grease fittings and pivot points
 - remove control panel and clean out the inside of the control box
 - beneath seat plate and top of transmission
2. Check the tire pressure. Inflate all traction unit tires to 20 psi.
3. Remove, sharpen and balance the cutting unit's blades. Reinstall the blades and torque the blade fasteners to 85–110 ft-lb (115–149 Nm).
4. Check all fasteners for looseness; tighten as necessary.
5. Grease or oil all grease fittings, pivot points, and transmission by-pass valve pins. Wipe off any excess lubricant.
6. Lightly sand and use touch up paint on painted areas that are scratched, chipped or rusted. Repair any dents in the metal body.
7. Service the battery and cables as follows:
 - a. Remove the battery terminals from the battery posts.
 - b. Clean the battery, terminals and posts with a wire brush and baking soda solution.
 - c. Coat the cable terminals and battery posts with Grafo 112X skin-over grease (Toro Part Number 505-47), or petroleum jelly to prevent corrosion.

- d. Slowly recharge the battery for 24 hours every 60 days to prevent lead sulfation of the battery.

Engine

1. Drain the engine oil from the oil pan and replace the drain plug.
2. Remove and discard the oil filter. Install a new filter.
3. Refill the engine with 3.8 quarts (3.6 l) of recommended motor oil. Refer to *Changing Crankcase Oil*.
4. Start the engine and run at idle speed for two minutes.
5. Drain diesel fuel from the fuel tank, fuel lines, pump, filter and separator. Flush fuel tank with clean diesel fuel and connect all fuel lines.
6. Thoroughly clean and service the air cleaner assembly.
7. Seal the air cleaner inlet and the exhaust outlet with weather proof masking tape.
8. Check the oil filler cap and fuel tank cap to ensure they are securely in place.

PRODUCT IDENTIFICATION

The traction unit has two identification numbers: a model number and a serial number that are stamped into a plate. The identification plate is located near the left brake pedal on the frame (Fig.). In any correspondence concerning the traction unit, supply the model and serial numbers to ensure correct information and replacement parts are obtained.

To order replacement parts from an Authorized TORO Distributor supply the following information:

1. Model and serial numbers of the traction unit.
2. Part number, description and quantity of parts desired.

Note: Do not order by reference number if a parts catalog is being used; use the part number.

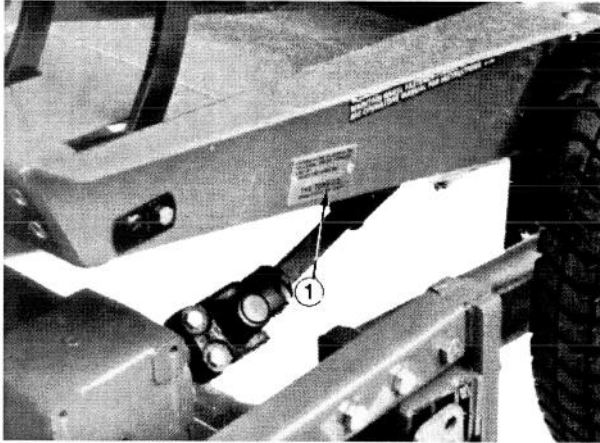

Figure 23

1. Model and serial ID plate

