



Count on it.

Operator's Manual

**Bore Drive Head Attachment
Compact Utility Loader**

Model No. 22420—Serial No. 315000001 and Up

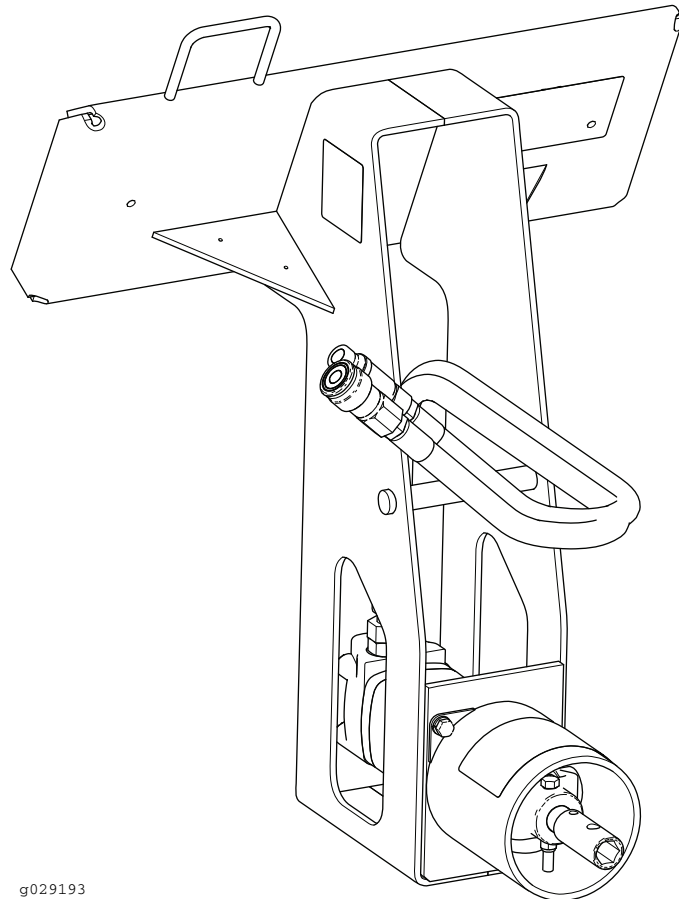

g029193



⚠ WARNING

**CALIFORNIA
Proposition 65 Warning**

This product contains a chemical or chemicals known to the State of California to cause cancer, birth defects, or reproductive harm.

Use of this product may cause exposure to chemicals known to the State of California to cause cancer, birth defects, or other reproductive harm.

This product complies with all relevant European directives. For details, please see the Declaration of Incorporation (DOI) at the back of this publication.

Introduction

The machine is a hydraulically powered auger attachment for Toro compact utility loaders. It is designed to dig vertical holes in earth for the installation of posts, plants, and other construction and landscaping needs. It is not intended to drill holes in pavement, concrete, or ice.

Read this information carefully to learn how to operate and maintain your product properly and to avoid injury and product damage. You are responsible for operating the product properly and safely.

You may contact Toro directly at www.Toro.com for product safety and operation training materials, accessory information, help finding a dealer, or to register your product.

Whenever you need service, genuine Toro parts, or additional information, contact an Authorized Service Dealer or Toro Customer Service and have the model and serial numbers of your product ready. [Figure 1](#) identifies the location of the model and serial numbers on the product. Write the numbers in the space provided.

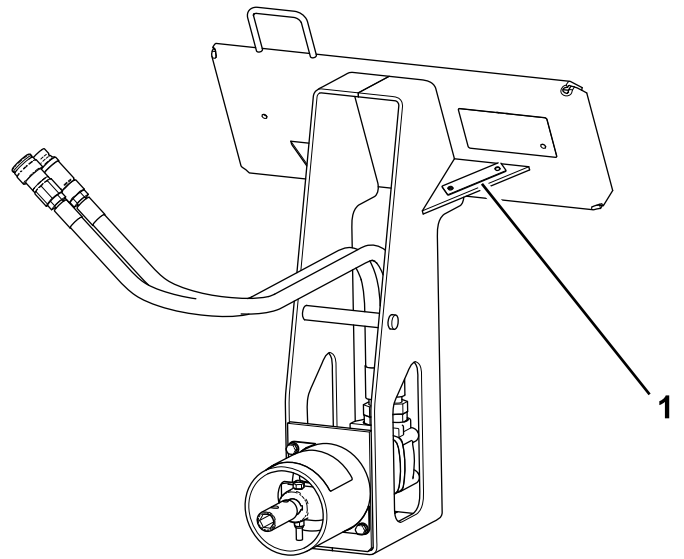

g029194
g029194

Figure 1

1. Model and serial number location

Model No. _____
Serial No. _____

This manual identifies potential hazards and has safety messages identified by the safety alert symbol ([Figure 2](#)), which signals a hazard that may cause serious injury or death if you do not follow the recommended precautions.



g000502

Figure 2

1. Safety alert symbol

This manual uses 2 words to highlight information.

Important calls attention to special mechanical information and **Note** emphasizes general information worthy of special attention.

Contents

Safety	3
Stability Ratings.....	4
Safety and Instructional Decals	5
Product Overview	5
Specifications	5
Operation	6
Installing Accessories.....	6
Removing an Accessory	6
Boring a Hole	6
Boring the Hole	6
Reaming the Hole.....	7
Storage	8
Troubleshooting	9

Safety

Improper use or maintenance by the operator or owner can result in injury. To reduce the potential for injury, comply with these safety instructions and those in the traction unit *Operator's Manual*. Always pay attention to the safety alert symbol, which means *Caution, Warning, or Danger*—personal safety instruction. Failure to comply with the instruction may result in personal injury or death.

To ensure optimum performance and continued safety certification of the machine, use only genuine Toro replacement parts and accessories. Replacement parts and accessories made by other manufacturers could be dangerous, and such use could void the product warranty.

DANGER

There may be buried power, gas, and/or telephone lines in the work area. Shock or explosion may occur if you dig into them.

Have the property or work area marked for buried lines and do not dig in marked areas. Contact your local marking service or utility company to have the property marked (for example, in the United States, call 811 for the nationwide marking service).

DANGER

Rotating rod and bits can entangle loose clothing, hands, arms, legs, and feet, causing death or serious injury.

- Keep at least ten feet from rotating parts, unless you are operating the rod guide tool.
- Never use anything but the rod guide tool for starting the rod and boring bit.
- Keep extremities and other parts of your body or clothing away from rotating parts.
- Do not wear loose clothing or jewelry while operating or assisting with the boring unit.
- Always turn off the traction unit and remove the key from the ignition before changing accessories.

WARNING

When the engine is off, attachments in the raised position can gradually lower. Someone nearby may be pinned or injured by the attachment as it lowers.

Always lower the attachment lift each time you shut off the traction unit.

⚠ WARNING

When going up or down hill, the machine could overturn if the heavy end is toward the downhill side. Someone may be pinned or seriously injured by the machine if it overturns.

Operate up and down slopes with the heavy end of the machine uphill. An attached trencher will make the front end heavy.

⚠ WARNING

If you do not fully seat the attachment locking pins in the attachment mount plate holes, the attachment could fall off of the traction unit severely injuring the operator or bystanders.

- Ensure that you fully seat the attachment locking pins through the holes in the attachment mount plate before lifting the attachment.
- Ensure that the attachment mount plate is free of any dirt or debris that may hinder the connection of the traction unit to the attachment.
- Refer to your traction unit *Operator's Manual* for detailed information on safely connecting an attachment to your traction unit.

⚠ WARNING

Lightning can cause severe injury or death. If lightning is seen or thunder is heard in the area, do not operate the machine; seek shelter.

⚠ CAUTION

Hydraulic couplers, hydraulic lines/valves, and hydraulic fluid may be hot and can burn you if you touch them.

- Wear gloves when operating the hydraulic couplers.
- Allow the traction unit to cool before touching hydraulic components.
- Do not touch hydraulic fluid spills.
- Do not service the attachment unless rod rotation is stopped, the auxiliary hydraulics lever is moved to neutral, and the engine of the traction unit is stopped.
- Never use bolts or pins in place of push button connectors.
- Always have 2 people operate the attachment, 1 to operate the traction unit and the other to guide the boring unit with the guide tool.
- Always use the guide tool to align the boring unit.
- Never straddle or stand on the rod when the engine is running.

⚠ CAUTION

Hydraulic couplers, hydraulic lines/valves, and hydraulic fluid may be hot and can burn you if you touch them.

- Wear gloves when operating the hydraulic couplers.
- Allow the traction unit to cool before touching hydraulic components.
- Use cardboard or paper to find hydraulic leaks, never use your hands.

Stability Ratings

To determine the degree of slope you can traverse with the attachment installed on a traction unit, find the stability rating for the hill position you want to travel in the appropriate table below, then find the degree of slope for the same rating and hill position in the Stability Data section of the traction unit *Operator's Manual*.



⚠ WARNING

Exceeding the maximum recommended slope can cause the traction unit to tip, crushing you or bystanders.

Do not drive the traction unit on a slope steeper than the maximum recommended slope, as determined in the following tables and the traction unit *Operator's Manual*.

Important: If you have a traction unit other than the TX, the bore drive head is rated for use without the counterweight. If you use the counterweight with the boring unit, the traction unit will be less stable in the front and side uphill positions.

Stability Rating

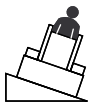
Orientation	Stability Rating
Front Uphill 	D
Rear Uphill 	B
Side Uphill 	C

Safety and Instructional Decals



Safety decals and instructions are easily visible to the operator and are located near any area of potential danger. Replace any decal that is damaged or lost.



99-9945

decal99-9945

1. Warning—read the *Operator's Manual*.
2. Entanglement hazard, shaft—keep bystanders a safe distance from the machine.
3. Explosion and electric shock hazard—do not dig in areas with buried gas or electrical lines; contact local power organizations before digging.

Product Overview

Specifications

Note: Specifications and design are subject to change without notice.

Width	61 cm (24 inches)
Length	56 cm (22 inches)
Height	63.5 cm (25 inches)
Weight	54 Kg (120 lb)
Boring diameter	3.2 to 8.9 cm (1.25 to 3.5 inches)

Attachments/Accessories

A selection of Toro approved attachments and accessories is available for use with the machine to enhance and expand its capabilities. Contact your Authorized Service Dealer or Distributor.

To best protect your investment and maintain optimal performance of your Toro equipment, count on Toro genuine parts. When it comes to reliability, Toro delivers replacement parts designed to the exact engineering specification of our equipment. For peace of mind, insist on Toro genuine parts.

Operation

Refer to your traction unit *Operator's Manual* for more information on installing and removing attachments on your traction unit.

Important: Always use the traction unit to lift and move the attachment.

Installing Accessories

Toro offers several different rods and bits for use with the attachment. Purchase accessories from your Toro dealer.

1. Stop the engine, wait for all moving parts to stop, and remove the key.
2. Slide the hex shaft of a rod, boring bit, or reamer into the socket. Align the hole in the socket with the push button connector (Figure 3).

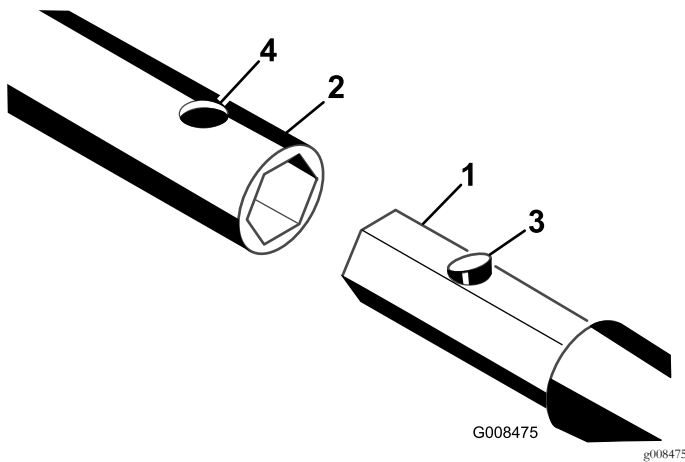

Figure 3

- | | |
|--------------------|--------------------------|
| 1. Accessory shaft | 3. Push button connector |
| 2. Socket | 4. Hole |

3. Press down the push button connector and push the shaft into the socket until the connector snaps into the hole in the socket (Figure 3).
4. Repeat steps 2 and 3.

Removing an Accessory

1. Stop the engine, wait for all moving parts to stop, and remove the key.
2. Press the push button connector securing the accessory shaft in the socket and pull the accessory free of the socket.

Boring a Hole

Digging the Trenches

Before drilling under a walk or driveway, you must make an entrance and an exit trench on either side of the drilling area.

Both trenches must be at least 15 cm (6 inch) wide and 46 cm (18 inch) deep. The entrance trench must be at least 2.13 m (7 feet) long and the exit trench 0.91 m (3 feet) to 1.8 m (6 feet) long. The entrance trench should be perpendicular to the walk or driveway (Figure 4) and the exit trench should be parallel to the walk or driveway. The exit trench should be centered across from the entrance trench (Figure 4).

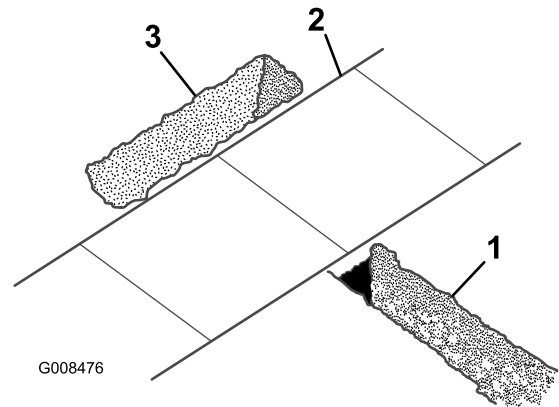

Figure 4

- | | |
|--------------------|----------------|
| 1. Entrance trench | 3. Exit trench |
| 2. Sidewalk | |

Boring the Hole

Important: Boring is a two person operation. Do not attempt to perform this operation by yourself.

1. Position the traction unit with the drive head at the beginning of the trench and lower it to the appropriate depth.
2. Stop the engine and wait for all moving parts to stop.
3. Connect a rod and boring bit onto the drive head.
4. Connect the rod guide tool to the rod just behind the boring bit (Figure 5).

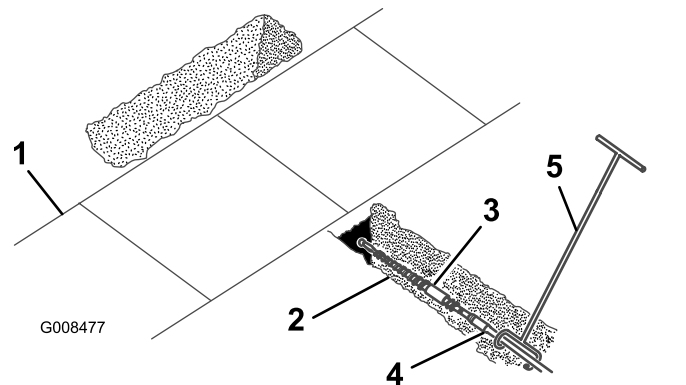

Figure 5

- | | |
|-------------------------|-------------------|
| 1. Sidewalk or driveway | 4. Rod |
| 2. Entrance trench | 5. Rod-guide tool |
| 3. Boring bit | |

5. With the person guiding the boring bit positioned to the right of the trench (Figure 5), start the engine, move the pump selector valve to slow (turtle) (200 and 300 series traction units only), position the throttle to within the middle of the rpm range, and pull the auxiliary hydraulics lever rearward to start the forward rotation of the boring bit.
 6. Slowly move the traction unit forward, while the person with the rod-guide tool guides the boring bit into the soil (Figure 5).
 7. Once the entire drill bit is in the soil, push the auxiliary hydraulics lever into neutral.
 8. Stop the engine and wait for all moving parts to stop.
 9. If the rod is not within the grade tolerances for the job being performed, start the engine and drive backward to pull the boring bit out of the soil, then repeat steps 5 through 9, making adjustments to correct the grade.
 10. Remove the rod-guide tool.
 11. Start the engine and pull the auxiliary hydraulics lever rearward to start the boring bit.
 12. Slowly move the traction unit forward as the boring bit digs into the soil.
- Important: Do not drive too fast, forcing the bit into the soil. Allow the bit to progress at its own rate. Never push or pull the bit through the soil when the drive head is not turning.**
13. When about 15 cm (6 inches) of rod are left showing in the entrance trench or when the boring bit completely enters and bores into the far side of the exit trench, stop the traction unit, push the auxiliary hydraulics lever into neutral, and stop the engine.
 14. If the boring bit has not yet entered the exit trench, complete the following:
 - A. Detach the rod from the drive head.
 - B. Start the engine and back up to the end of the entrance trench.
 - C. Stop engine and wait for all moving parts to stop.
 - D. Connect another rod and repeat steps 11 through 14.

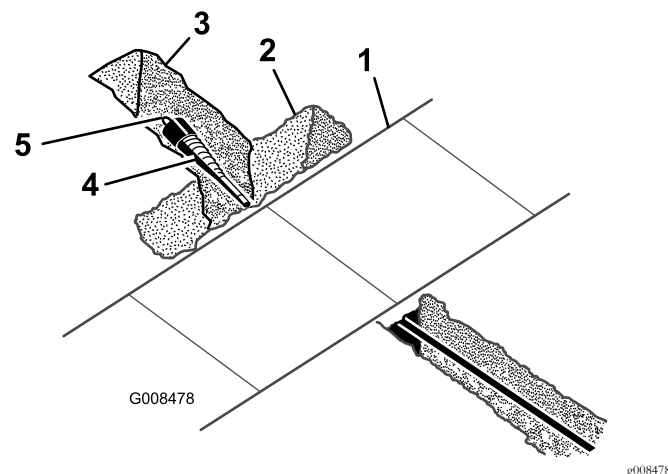

Figure 6

- | | |
|-----------------------------------|-----------|
| 1. Sidewalk or driveway | 4. Reamer |
| 2. Exit trench | 5. Swivel |
| 3. Shovel dug-out area around bit | |

2. Remove the boring bit and attach the reamer (Figure 6).
3. Attach the cable or piping being installed to the swivel on the end of the reamer (Figure 6).
4. Start the engine and pull the auxiliary hydraulics lever rearward to start the reamer.
5. Slowly move the traction unit rearward as the reamer digs into the soil.

Important: Do not drive too fast, forcing the reamer into the soil. Allow the reamer to progress at its own rate. Never push or pull the reamer through the soil when the drive head is not turning.

6. When a rod coupling is about 15 cm (6 inches) into the entrance trench or when the reamer completely enters the trench with about 15 cm (6 inches) of the cable or piping, stop the traction unit, pull the auxiliary hydraulics lever into neutral, and stop engine.
7. If the reamer has not yet entered the exit trench, complete the following:
 - A. Detach the rod from the drive head and rod still in the soil.
 - B. Start the engine and move to the front of the entrance trench.
 - C. Stop the engine and wait for all moving parts to stop.
 - D. Connect the drive head to the rod shaft in the soil.
 - E. Repeat steps 4 through 7.
8. With the reamer and cable/piping in the entrance trench, remove the cable or piping from the reamer.

Reaming the Hole

1. With a shovel, carefully dig around the boring bit, clearing it of soil until it can be removed (Figure 6).

Storage

1. Before long term storage, wash the attachment with mild detergent and water to remove dirt and grime.
2. Check the condition of the hydraulic hoses. Replace any damaged hoses.
3. Ensure that all hydraulic couplers are connected together to prevent contamination of the hydraulic system.
4. Check and tighten all bolts, nuts, and screws. Repair or replace any damaged or worn part.
5. Paint all scratched or bare metal surfaces. Paint is available from your Authorized Service Dealer.
6. Store the attachment in a clean, dry garage or storage area. Cover it to protect it and keep it clean.

Troubleshooting

Problem	Possible Cause	Corrective Action
The bore drive head does not rotate.	The hydraulic coupler is not completely connected	Check and tighten all couplers.
	A hydraulic coupler is damaged.	Check the couplers and replace any that are damaged.
	There is an obstruction in a hydraulic hose.	Find and remove the obstruction.
	A hydraulic hose is kinked.	Replace the kinked hose.
	The auxiliary valve on the traction unit is not opening.	Repair the valve.
	A hydraulic motor is damaged or worn.	Replace or repair the motor.

Declaration of Incorporation

The Toro Company, 8111 Lyndale Avenue South, Bloomington, MN, USA declares that the following unit(s) conform(s) to the directives listed, when installed in accordance with the accompanying instructions onto certain Toro models as indicated on the relevant Declarations of Conformity.

Model No.	Serial No.	Product Description	Invoice Description	General Description	Directive
22420	315000001 and Up	Bore Drive Head Attachment	BORE DRIVE HEAD ATTACHMENT CE	Compact Utility Loader	2006/42/EC

Relevant technical documentation has been compiled as required per Part B of Annex VII of 2006/42/EC.

We will undertake to transmit, in response to requests by national authorities, relevant information on this partly completed machinery. The method of transmission shall be electronic transmittal.

This machinery shall not be put into service until incorporated into approved Toro models as indicated on the associated Declaration of Conformity and in accordance with all instructions, whereby it can be declared in conformity with all relevant Directives.

Certified:



Joe Hager
Sr. Engineering Manager
8111 Lyndale Ave. South
Bloomington, MN 55420, USA
February 4, 2015

EU Technical Contact:

Marcel Dutrieux
Manager European Product Integrity
Toro Europe NV
Nijverheidsstraat 5
2260 Oevel
Belgium
Tel. +32 16 386 659

International Distributor List

Distributor:	Country:	Phone Number:	Distributor:	Country:	Phone Number:
Agrolanc Kft	Hungary	36 27 539 640	Maquiver S.A.	Colombia	57 1 236 4079
Balama Prima Engineering Equip.	Hong Kong	852 2155 2163	Maruyama Mfg. Co. Inc.	Japan	81 3 3252 2285
B-Ray Corporation	Korea	82 32 551 2076	Mountfield a.s.	Czech Republic	420 255 704 220
Casco Sales Company	Puerto Rico	787 788 8383	Mountfield a.s.	Slovakia	420 255 704 220
Ceres S.A.	Costa Rica	506 239 1138	Munditol S.A.	Argentina	54 11 4 821 9999
CSSC Turf Equipment (pvt) Ltd.	Sri Lanka	94 11 2746100	Norma Garden	Russia	7 495 411 61 20
Cyril Johnston & Co.	Northern Ireland	44 2890 813 121	Oslinger Turf Equipment SA	Ecuador	593 4 239 6970
Cyril Johnston & Co.	Republic of Ireland	44 2890 813 121	Oy Hako Ground and Garden Ab	Finland	358 987 00733
Equiver	Mexico	52 55 539 95444	Parkland Products Ltd.	New Zealand	64 3 34 93760
Femco S.A.	Guatemala	502 442 3277	Perfetto	Poland	48 61 8 208 416
ForGarder OU	Estonia	372 384 6060	Pratoverde SRL.	Italy	39 049 9128 128
G.Y.K. Company Ltd.	Japan	81 726 325 861	Prochaska & Cie	Austria	43 1 278 5100
Geomechaniki of Athens	Greece	30 10 935 0054	RT Cohen 2004 Ltd.	Israel	972 986 17979
Golf international Turizm	Turkey	90 216 336 5993	Riversa	Spain	34 9 52 83 7500
Guandong Golden Star	China	86 20 876 51338	Lely Turfcare	Denmark	45 66 109 200
Hako Ground and Garden	Sweden	46 35 10 0000	Solvart S.A.S.	France	33 1 30 81 77 00
Hako Ground and Garden	Norway	47 22 90 7760	Spypros Stavrinides Limited	Cyprus	357 22 434131
Hayter Limited (U.K.)	United Kingdom	44 1279 723 444	Surge Systems India Limited	India	91 1 292299901
Hydroturf Int. Co Dubai	United Arab Emirates	97 14 347 9479	T-Markt Logistics Ltd.	Hungary	36 26 525 500
Hydroturf Egypt LLC	Egypt	202 519 4308	Toro Australia	Australia	61 3 9580 7355
Irrimac	Portugal	351 21 238 8260	Toro Europe NV	Belgium	32 14 562 960
Irrigation Products Int'l Pvt Ltd.	India	0091 44 2449 4387	Valtech	Morocco	212 5 3766 3636
Jean Heybroek b.v.	Netherlands	31 30 639 4611	Victus Emak	Poland	48 61 823 8369

European Privacy Notice

The Information Toro Collects

Toro Warranty Company (Toro) respects your privacy. In order to process your warranty claim and contact you in the event of a product recall, we ask you to share certain personal information with us, either directly or through your local Toro company or dealer.

The Toro warranty system is hosted on servers located within the United States where privacy law may not provide the same protection as applies in your country.

BY SHARING YOUR PERSONAL INFORMATION WITH US, YOU ARE CONSENTING TO THE PROCESSING OF YOUR PERSONAL INFORMATION AS DESCRIBED IN THIS PRIVACY NOTICE.

The Way Toro Uses Information

Toro may use your personal information to process warranty claims, to contact you in the event of a product recall and for any other purpose which we tell you about. Toro may share your information with Toro's affiliates, dealers or other business partners in connection with any of these activities. We will not sell your personal information to any other company. We reserve the right to disclose personal information in order to comply with applicable laws and with requests by the appropriate authorities, to operate our systems properly or for our own protection or that of other users.

Retention of your Personal Information

We will keep your personal information as long as we need it for the purposes for which it was originally collected or for other legitimate purposes (such as regulatory compliance), or as required by applicable law.

Toro's Commitment to Security of Your Personal Information

We take reasonable precautions in order to protect the security of your personal information. We also take steps to maintain the accuracy and current status of personal information.

Access and Correction of your Personal Information

If you would like to review or correct your personal information, please contact us by email at legal@toro.com.

Australian Consumer Law

Australian customers will find details relating to the Australian Consumer Law either inside the box or at your local Toro Dealer.



The Toro Underground Warranty

Underground
Equipment

A Limited Warranty

Conditions and Products Covered

The Toro Company and its affiliate, Toro Warranty Company, pursuant to an agreement between them, jointly warrant your Toro Underground Equipment ("Product") to be free from defects in materials or workmanship. Where a warrantable condition exists, we will repair the Product at no cost to you including diagnostics, labor, and parts. The following warranty applies from the date the Product is delivered to the original retail purchaser or rental owner.

Products

Engine Powered Units & Fluid Mixers

All Serialized Attachments

Rock Hammer

Engines

Warranty Period

1 year or 1000 operating hours, whichever occurs first

1 year

6 months

Through engine manufacturers:
2 years or 2000 operating hours, whichever occurs first

drive, or track chains, track pads, drive sprockets, idlers, rollers, blades, cutting edges, or other ground engaging components.

- Failures caused by outside influence. Conditions considered to be outside influence include, but are not limited to, weather, storage practices, contamination, use of unapproved fuels, coolants, lubricants, additives, water, or chemicals, etc.
- Failure or performance issues due to the use of fuels (e.g. gasoline, diesel, or biodiesel) that do not conform to their respective industry standards.
- Normal noise, vibration, wear and tear, and deterioration.
- Normal "wear and tear" includes, but is not limited to, damage to seats due to wear or abrasion, worn painted surfaces, scratched decals, etc.
- Hauling expenses, travel time, mileage, or overtime associated with transporting product to the authorized Toro dealer.

Instructions for Obtaining Warranty Service

You are responsible for notifying the Underground Dealer from whom you purchased the Product as soon as you believe a warrantable condition exists. If you need help locating a Underground Dealer, or if you have questions regarding your warranty rights or responsibilities, you may contact us at:

Toro Customer Care
Toro Warranty Company
8111 Lyndale Avenue South
Bloomington, MN 55420-1196
Toll Free at 855-493-0088 (U.S. Customers)
1-952-948-4318 (International Customers)

Owner Responsibilities

As the Product owner, you are responsible for required maintenance and adjustments stated in your *Operator's Manual*. Failure to perform required maintenance and adjustments can be grounds for disallowing a warranty claim.

Items and Conditions Not Covered

Not all product failures or malfunctions that occur during the warranty period are defects in materials or workmanship. This warranty does not cover the following:

- Product failures which result from the use of non-Toro replacement parts, or from installation and use of add-on, or modified non-Toro branded accessories and products. A separate warranty may be provided by the manufacturer of these items.
- Product failures which result from failure to perform recommended maintenance and/or adjustments. Failure to properly maintain your Toro product per the Recommended Maintenance listed in the *Operator's Manual* can result in claims for warranty being denied.
- Product failures which result from operating the Product in an abusive, negligent, or reckless manner.
- Parts subject to consumption through use unless found to be defective. Examples of parts which are consumed, or used up, during normal Product operation include, but are not limited to: brakes, filters, lights, bulbs, belts, tracks or tires, digging teeth, digging booms, digging,

Parts

Parts scheduled for replacement as required maintenance in the *Operator's Manual*, are warranted for the period of time up to the scheduled replacement time for that part. Parts replaced under this warranty are covered for the duration of the original product warranty and become the property of Toro. Toro will make the final decision whether to repair any existing part or assembly or replace it. Toro may use remanufactured parts for warranty repairs.

Maintenance is at Owner's Expense

Engine tune-up, lubrication, cleaning and polishing, replacement of filters, coolant, and completing recommended maintenance are some of the normal services Toro products require that are at the owner's expense.

General Conditions

Repair by an Authorized Toro Underground Dealer is your sole remedy under this warranty.

Neither The Toro Company nor Toro Warranty Company is liable for indirect, incidental or consequential damages in connection with the use of the Toro Products covered by this warranty, including any cost or expense of providing substitute equipment or service during reasonable periods of malfunction or non-use pending completion of repairs under this warranty. Except for the Emissions warranty referenced below, if applicable, there is no other express warranty. All implied warranties of merchantability and fitness for use are limited to the duration of this express warranty.

Some states do not allow exclusions of incidental or consequential damages, or limitations on how long an implied warranty lasts, so the above exclusions and limitations may not apply to you. This warranty gives you specific legal rights, and you may also have other rights which vary from state to state.

Note regarding engine warranty:

The Emissions Control System on your Product may be covered by a separate warranty meeting requirements established by the U.S. Environmental Protection Agency (EPA) and/or the California Air Resources Board (CARB). The hour limitations set forth above do not apply to the Emissions Control System Warranty. Refer to the Engine Emission Control Warranty Statement supplied with your product or contained in the engine manufacturer's documentation for details.

Countries Other than the United States or Canada

Customers who have purchased Toro products exported from the United States or Canada should contact their Toro Distributor (Dealer) to obtain guarantee policies for your country, province, or state. If for any reason you are dissatisfied with your Underground Dealer's service or have difficulty obtaining guarantee information, contact the Toro importer.

Australian Consumer Law: Australian customers will find details relating to the Australian Consumer Law either inside the box or at your local Toro Dealer.