



Bucket Seat Base Kit

Workman® GTX Series Utility Vehicles

Model No. 07048

Installation Instructions

▲ WARNING

CALIFORNIA Proposition 65 Warning

This product contains a chemical or chemicals known to the State of California to cause cancer, birth defects, or reproductive harm.

Installation

Loose Parts

Use the chart below to verify that all parts have been shipped.

Description	Qty.	Use
No parts required	–	Prepare the machine.
Seat assembly	1	Install the bucket seat.

Important: You must install the Seat Hinge Kit before installing the Bucket Seat Base Kit.

Preparing the Machine

1. Park the machine on a level surface.
2. Engage the parking brake.
3. Shut off the engine and remove the key from the key switch.

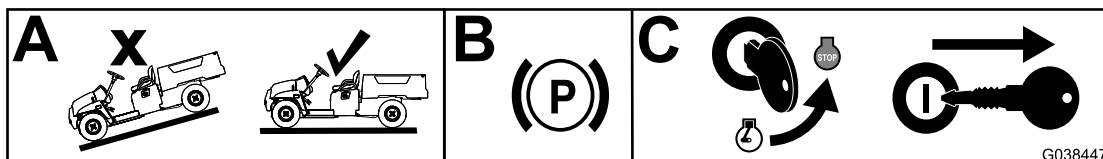

Figure 1

g038447



Installing the Bucket Seat

Slide the seat assembly onto the pins and lower the seat assembly (Figure 2).

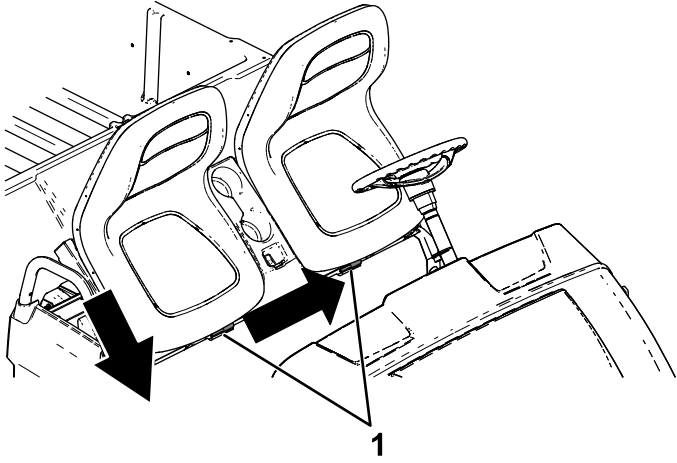

Figure 2

g190186

1. Pins
