



Count on it.

Operator's Manual

**Groundsmaster® 4000 or 4010
Rotary Mower**

Model No. 30605—Serial No. 400000000 and Up

Model No. 30635—Serial No. 400000000 and Up



This product complies with all relevant European directives; for details please see the separate product specific Declaration of Conformity (DOC) sheet.

⚠ WARNING

**CALIFORNIA
Proposition 65 Warning**

This product contains a chemical or chemicals known to the State of California to cause cancer, birth defects, or reproductive harm.

Diesel engine exhaust and some of its constituents are known to the State of California to cause cancer, birth defects, and other reproductive harm.

It is a violation of California Public Resource Code Section 4442 or 4443 to use or operate the engine on any forest-covered, brush-covered, or grass-covered land unless the engine is equipped with a spark arrester, as defined in Section 4442, maintained in effective working order or the engine is constructed, equipped, and maintained for the prevention of fire.

Introduction

This machine is a ride-on, rotary-blade lawnmower intended to be used by professional, hired operators in commercial applications. It is primarily designed for cutting grass on well-maintained lawns in parks, sports fields, and on commercial grounds. It is not designed for cutting brush, mowing grass and other growth alongside highways, or for agricultural uses.

Read this information carefully to learn how to operate and maintain your product properly and to avoid injury and product damage. You are responsible for operating the product properly and safely.

You may contact Toro directly at www.Toro.com for product and accessory information, help finding a dealer, or to register your product.

Whenever you need service, genuine Toro parts, or additional information, contact an Authorized Service Dealer or Toro Customer Service and have the model and serial numbers of your product ready. [Figure 1](#) identifies the location of the model and serial numbers on the product. Write the numbers in the space provided.

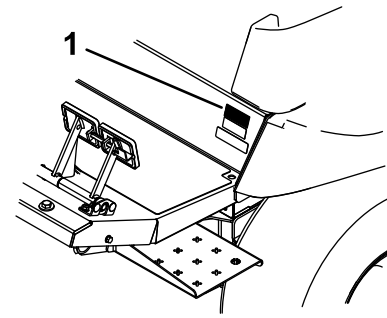

Figure 1

1. Model and serial number location

Model No. _____

Serial No. _____

This manual identifies potential hazards and has safety messages identified by the safety-alert symbol ([Figure 2](#)), which signals a hazard that may cause serious injury or death if you do not follow the recommended precautions.



Figure 2

1. Safety-alert symbol

This manual uses 2 words to highlight information. **Important** calls attention to special mechanical information and **Note** emphasizes general information worthy of special attention.

Contents

Safety	4	Daily Maintenance Checklist	41
General Safety.....	4	Service-Interval Chart.....	42
Engine-Emission Certification	4	Pre-Maintenance Procedures	44
Safety and Instructional Decals	5	Pre-Maintenance Safety.....	44
Setup	14	Preparing the Machine for Maintenance.....	44
1 Greasing the Machine.....	14	Removing the Hood	44
2 Replacing the Warning Decal	14	Lubrication	45
Product Overview	15	Greasing the Bearings and Bushings.....	45
Controls	15	Engine Maintenance	47
Cab Controls.....	17	Engine Safety.....	47
Specifications	22	Servicing the Engine Oil.....	47
Attachments/Accessories.....	23	Servicing the Air Cleaner	49
Before Operation	23	Servicing the Diesel Particulate Filter (DPF)	50
Before Operation Safety.....	23	Servicing the Diesel Oxidation Catalyst (DOC)	50
Checking the Engine-Oil Level.....	24	Fuel System Maintenance	50
Checking the Cooling System.....	24	Servicing the Fuel System	50
Checking the Hydraulic System	24	Servicing the Water Separator.....	50
Filling the Fuel Tank.....	24	Servicing the Fuel Filter.....	51
Checking the Tire Pressure	25	Electrical System Maintenance	52
Checking the Torque of the Wheel-Lug Nuts	25	Electrical System Safety.....	52
Checking the Planetary-Gear-Drive Oil	26	Servicing the Battery.....	52
Checking the Rear-Axle Lubricant.....	26	Locating the Fuses.....	53
Checking the Rear-Axle-Gearbox Lubricant	26	Drive System Maintenance	54
Adjusting the Rollover Protection System (ROPS)	27	Adjusting the Traction-Pedal Angle.....	54
Adjusting the Height of Cut.....	27	Changing the Planetary-Gear-Drive Oil	54
Adjusting the Skids.....	30	Changing the Rear-Axle Oil	55
Adjusting the Mower-Deck Rollers	30	Checking the Rear Wheel Toe-In	55
Correcting a Mismatch Between the Mower Decks.....	31	Cooling System Maintenance	56
Checking the Safety-Interlock Switches.....	32	Cooling System Safety.....	56
Adjusting the Mirrors.....	32	Checking the Cooling System	56
Aiming the Headlights	33	Servicing the Engine-Cooling System	56
During Operation	33	Brake Maintenance	57
During Operation Safety	33	Adjusting the Service Brakes	57
Starting the Engine.....	34	Belt Maintenance	57
Shutting Off the Engine	34	Servicing the Alternator Belt	57
Understanding Smart Power™ Traction	34	Servicing the Compressor Belt	57
Reversing Fan Operation.....	35	Tensioning the Blade-Drive Belts.....	58
Understanding Auto Idle.....	35	Replacing the Blade-Drive Belt.....	58
Using Cruise Control	35	Hydraulic System Maintenance	59
Using the Engine-Speed Switch.....	35	Hydraulic System Safety	59
Adjusting the Mowing Speed.....	35	Servicing the Hydraulic System.....	59
Adjusting the Transport Speed	35	Mower Maintenance.....	62
Understanding the Operating Characteristics of the Machine	35	Pivoting (Tilting) the Front Mower Deck to the Upright Position.....	62
Operating Tips	36	Pivoting the Front Mower Deck Down.....	62
After Operation	37	Adjusting the Mower-Deck Pitch.....	62
After Operation Safety.....	37	Servicing the Caster-Arm Bushings	63
Pushing or Towing the Machine.....	38	Servicing the Caster Wheels and Bearings.....	63
Locating the Jacking Points.....	38	Blade Maintenance	64
Hauling the Machine.....	38	Blade Safety.....	64
Locating the Tie-Down Points.....	38	Checking for a Bent Blade.....	64
Maintenance	39	Removing and Installing the Mower Blade(s)	65
Recommended Maintenance Schedule(s)	39	Inspecting and Sharpening the Mower Blade(s).....	65
		Correcting a Mower-Deck Mismatch.....	66
		Cab Maintenance	67
		Cleaning the Cab Air Filters	67

Cleaning the Cab Pre-Filter	67
Cleaning the Air-Conditioning Assembly	67
Cleaning	68
Storage	69
Preparing for Seasonal Storage	69

Safety

This machine has been designed in accordance with EN ISO 5395:2013 and ANSI B71.4-2012.

General Safety

This product is capable of amputating hands and feet and of throwing objects. Always follow all safety instructions to avoid serious personal injury.

Using this product for purposes other than its intended use could prove dangerous to you and bystanders.

- Read and understand the contents of this *Operator's Manual* before starting the engine.
- Do not put your hands or feet near moving components of the machine.
- Do not operate the machine without all guards and other safety protective devices in place and working on the machine.
- Keep clear of any discharge opening. Keep bystanders and pets a safe distance away from the machine.
- Keep children out of the operating area. Never allow children to operate the machine.
- Stop the machine and shut off the engine before servicing, fueling, or unclogging the machine.

Improperly using or maintaining this machine can result in injury. To reduce the potential for injury, comply with these safety instructions and always pay attention to the safety-alert symbol, which means Caution, Warning, or Danger—personal safety instruction. Failure to comply with these instructions may result in personal injury or death.

You can find additional safety information where needed throughout this *Operator's Manual*.

Engine-Emission Certification

The engine in this machine is EPA Tier 4i and EU Stage 3b emissions compliant.

Safety and Instructional Decals



Safety decals and instructions are easily visible to the operator and are located near any area of potential danger. Replace any decal that is damaged or missing.

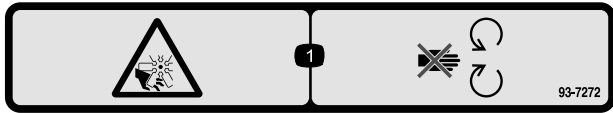

decal93-7272

93-7272

1. Cutting/dismemberment hazard; fan—stay away from moving parts.

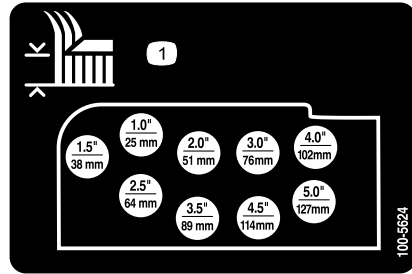

decal100-5624

100-5624

1. Height-of-cut adjustment

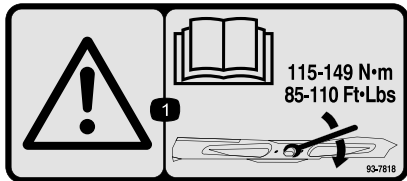

decal93-7818

93-7818

1. Warning—read the *Operator's Manual* for instructions on torquing the blade bolt/nut to 115-149 N·m (85-110 ft-lb).

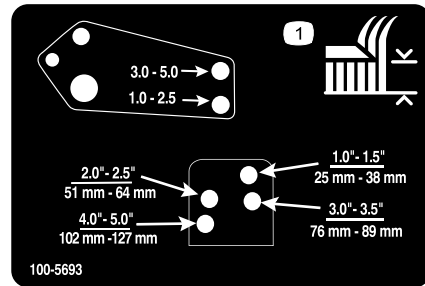

decal100-5693

100-5693

1. Height-of-cut adjustment

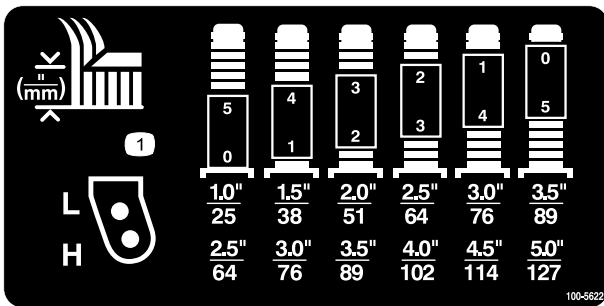

decal100-5622

100-5622

1. Height-of-cut adjustment

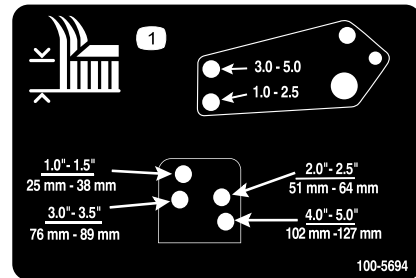

decal100-5694

100-5694

1. Height-of-cut adjustment

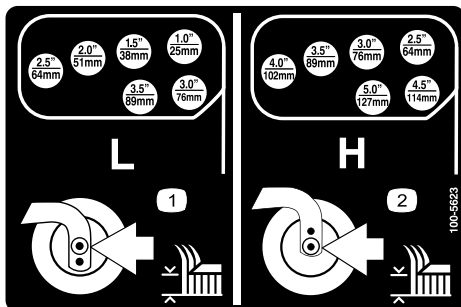

decal100-5623

100-5623

1. Low height-of-cut adjustment
2. High height-of-cut adjustment

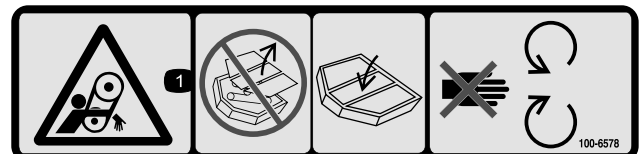

decal100-6578

100-6578

1. Entanglement hazard, belt—do not operate the machine with the shields or guards removed; always keep the shields and guards in place; stay away from moving parts.

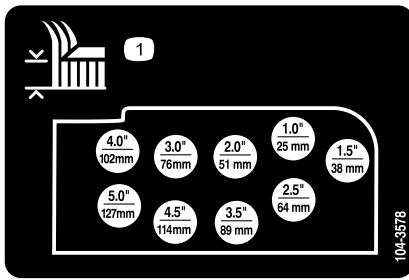

104-3578

1. Height-of-cut adjustment

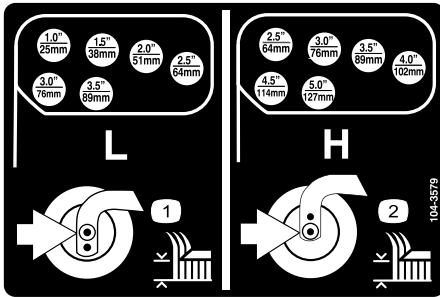

104-3579

1. Low height-of-cut adjustment
2. High height-of-cut adjustment

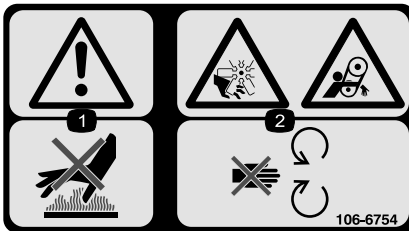

106-6754

1. Warning—do not touch the hot surface.
2. Cutting/dismemberment hazard, fan and entanglement hazard, belt—stay away from moving parts.

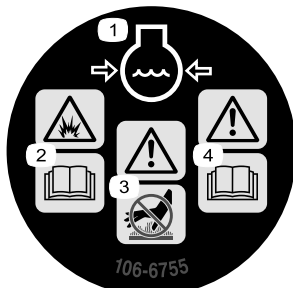

106-6755

1. Engine coolant under pressure.
2. Explosion hazard—read the *Operator's Manual*.
3. Warning—do not touch the hot surface.
4. Warning—read the *Operator's Manual*.

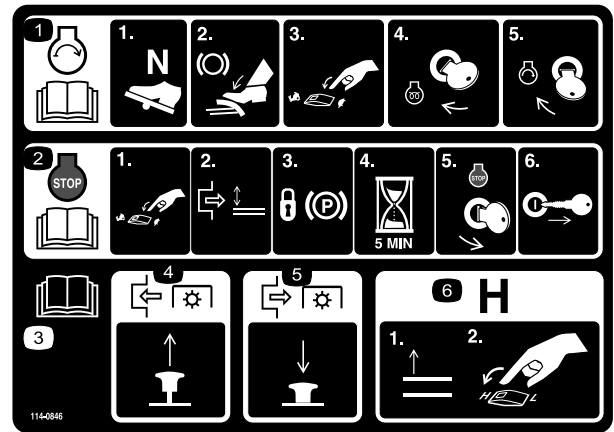

114-0846

1. Read the *Operator's Manual* for information on starting the engine—1) Set to neutral; 2) Engage the brake; 3) Set the engine speed to slow; 4) Turn the key to preheat; 5) Turn the key to start the engine.
2. Read the *Operator's Manual* for information on shutting of the engine—1) Set the engine speed to slow; 2) Disengage the deck; 3) Lock the parking brake; 4) Wait 5 minutes; 5) Turn the key to shut off engine; 6) Remove the key from the switch.
3. Read the *Operator's Manual*.
4. Pull the knob out to engage the PTO.
5. Push the knob in to disengage the PTO.
6. Raise the decks to go to H range.

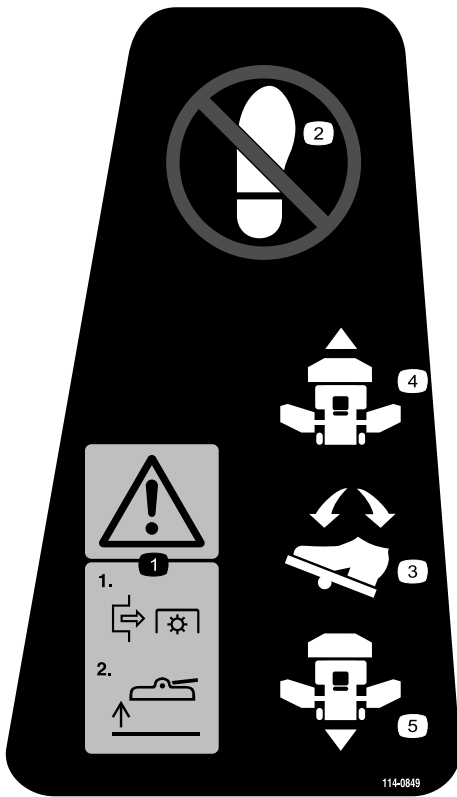

114-0849

decal114-0849

1. Warning—1) Disengage the PTO; 2) Raise the deck
2. Do not place your foot here.
3. Direction pedal
4. Forward direction
5. Reverse direction

CALIFORNIA SPARK ARRESTER WARNING

Operation of this equipment may create sparks that can start fires around dry vegetation. A spark arrester may be required. The operator should contact local fire agencies for laws or regulations relating to fire prevention requirements.

117-2718

decal117-2718

117-2718

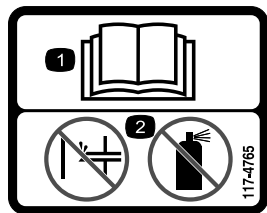

117-4765

decal117-4765

1. Read the *Operator's Manual*.
2. Do not use starting aids.

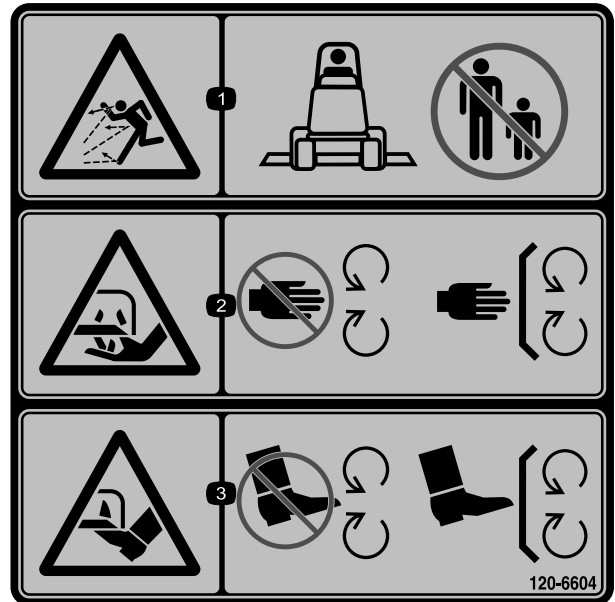

120-6604

decal120-6604

120-6604

1. Thrown object hazard—keep bystanders away from the machine.
2. Cutting/dismemberment hazard of hand, mower blade—stay away from moving parts, keep all guards and shields in place.
3. Cutting/dismemberment hazard of foot, mower blade—stay away from moving parts, keep all guards and shields in place.

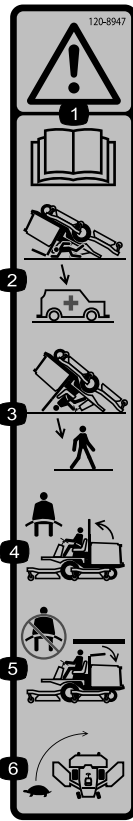

120-8947

decal120-8947

1. Warning—read the *Operator's Manual*.
2. There is no rollover protection when the roll bar is down.
3. There is rollover protection when the roll bar is up.
4. If the roll bar is raised, wear the seat belt.
5. If the roll bar is lowered, do not wear the seat belt.
6. Drive slowly when turning.

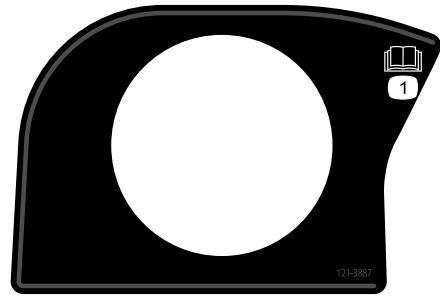

121-3887

decal121-3887

1. Read the *Operator's Manual*.

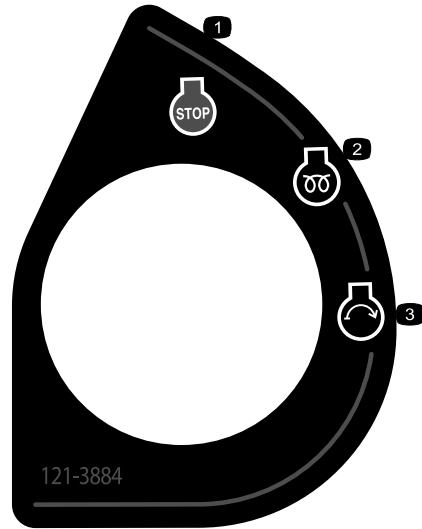

121-3884

decal121-3884

1. Engine stop
2. Engine preheat
3. Engine start

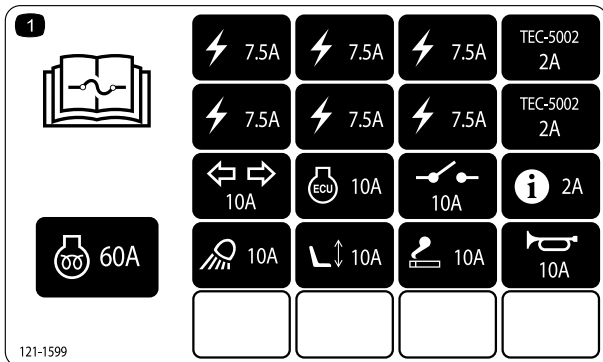

121-1599

decal121-1599

121-1599

1. Read the *Operator's Manual* for information on fuses.



Battery Symbols

Some or all of these symbols are on your battery

1. Explosion hazard
2. No fire, open flame, or smoking
3. Caustic liquid/chemical burn hazard
4. Wear eye protection.
5. Read the *Operator's Manual*.
6. Keep bystanders a safe distance away from the battery.
7. Wear eye protection; explosive gases can cause blindness and other injuries.
8. Battery acid can cause blindness or severe burns.
9. Flush eyes immediately with water and get medical help fast.
10. Contains lead; do not discard

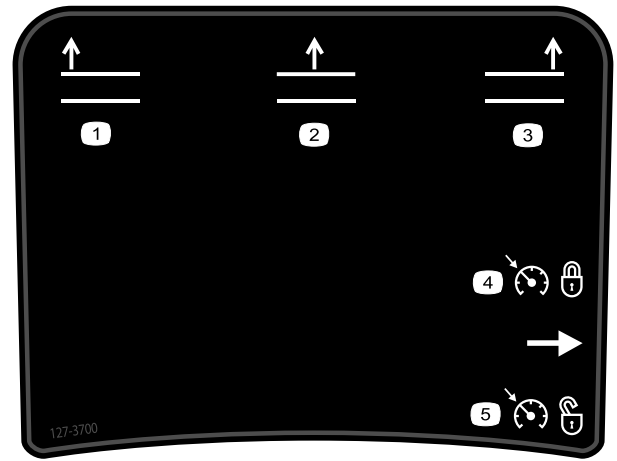

127-3700

1. Raise the left deck.
2. Raise the center deck.
3. Raise the right deck.
4. Lock the engine speed.
5. Unlock the engine speed.

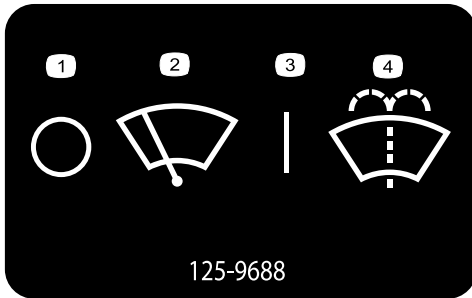

125-9688

Model with Cab Only

1. Windshield wipers (off)
2. Windshield wipers
3. Windshield wipers (on)
4. Spray windshield washer fluid

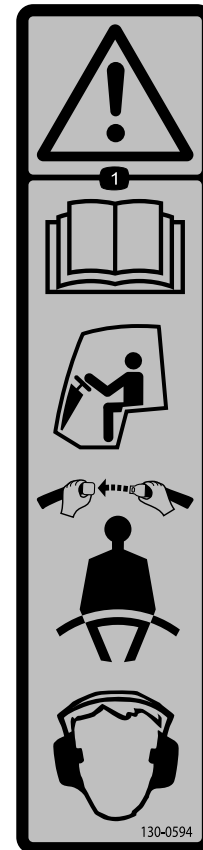

130-0594

1. Warning—read the *Operator's Manual*; when sitting in the cab, always wear a seat belt; wear hearing protection.

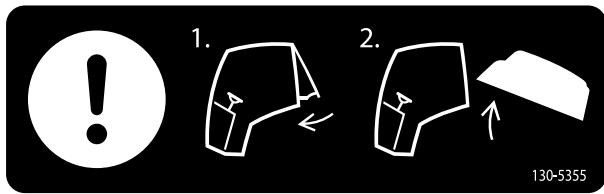

130-5355

decal130-5355

1. Close the rear window.
2. Raise the hood.

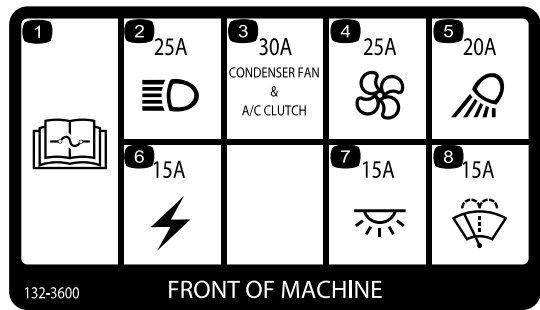

132-3600

Model with Cab Only

132-3600

FRONT OF MACHINE

decal132-3600

1. Read the *Operator's Manual* for more information on fuses.
2. Headlight (25 A)
3. Condenser fan and A/C clutch (30 A)
4. Fan (25 A)
5. Working light (20 A)
6. Auxiliary power (15 A)
7. Cab light (15 A)
8. Windshield wipers (15 A)

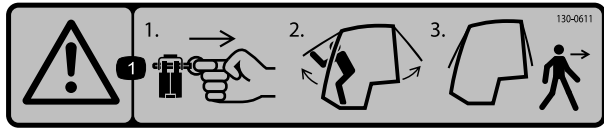

130-0611

decal130-0611

Model with Cab Only

1. Warning—1) Remove the pin; 2) Raise the doors; 3) Exit the cab.



130-5356

decal130-5356

1. Use the foot pedal to move forward or in reverse.

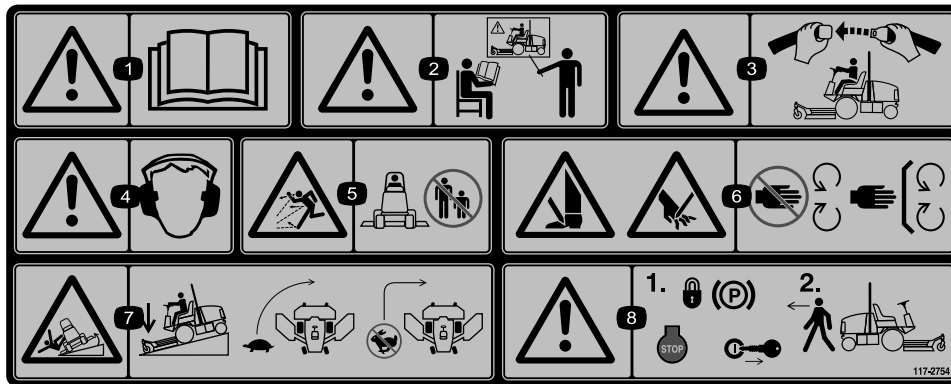

117-2754

decal117-2754

1. Warning—read the *Operator's Manual*.
2. Warning—do not operate this machine unless you are trained.
3. Warning—wear the seat belt when seated in the operator's position.
4. Warning—wear hearing protection.
5. Thrown object hazard—keep bystanders a safe distance away from the machine.
6. Cutting hazard of hand or foot—stay away from moving parts; keep all guards in place.
7. Tipping hazard—lower the cutting unit when driving down slopes; slow machine before turning, do not turn at high speeds
8. Warning—lock the parking brake, shut off the engine, and remove the key from the switch before leaving the machine.

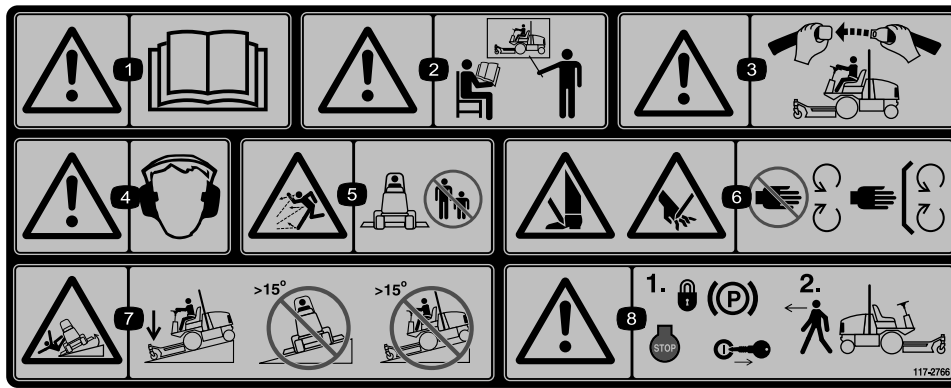

decal117-2766

117-2766

(Affix over Part No. 117-2754 for CE*)

* This safety decal includes a slope warning required on the machine for compliance to the European Lawn Mower Safety Standard EN ISO 5395:2013. The conservative maximum slope angles indicated for operation of this machine are prescribed by and required by this standard. This machine complies with the industry standard stability test in the static lateral and longitudinal tests with the maximum recommended slope indicated on the decal. Review the instructions for operating the machine on slopes in the *Operator's Manual* and the conditions in which the machine is being operated to determine whether the machine can be operated in the conditions on that day and at that site. Changes in the terrain can result in a change in slope operation for the machine. If possible, keep the cutting units lowered to the ground while operating the machine on slopes. Raising the cutting units while operating on slopes can cause the machine to become unstable.

1. Warning—read the *Operator's Manual*.
2. Warning—do not operate this machine unless you are trained.
3. Warning—wear the seat belt when seated in the operator's position.
4. Warning—wear hearing protection.
5. Thrown object hazard—keep bystanders a safe distance away from the machine.
6. Cutting hazard of hand or foot—stay away from moving parts; keep all guards in place.
7. Tipping hazard—lower the cutting unit when driving down slopes; do not operate machine on slopes greater than 15 degrees.
8. Warning—lock the parking brake, shut off the engine, and remove the key from the switch before leaving the machine.

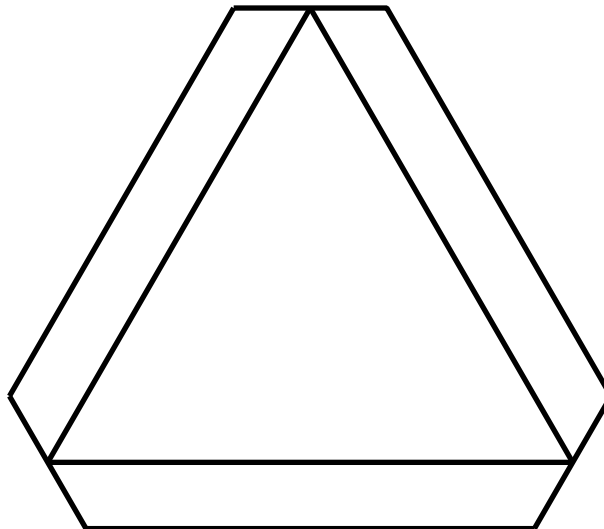

120-0250

decal120-0250

1. Slow-moving vehicle

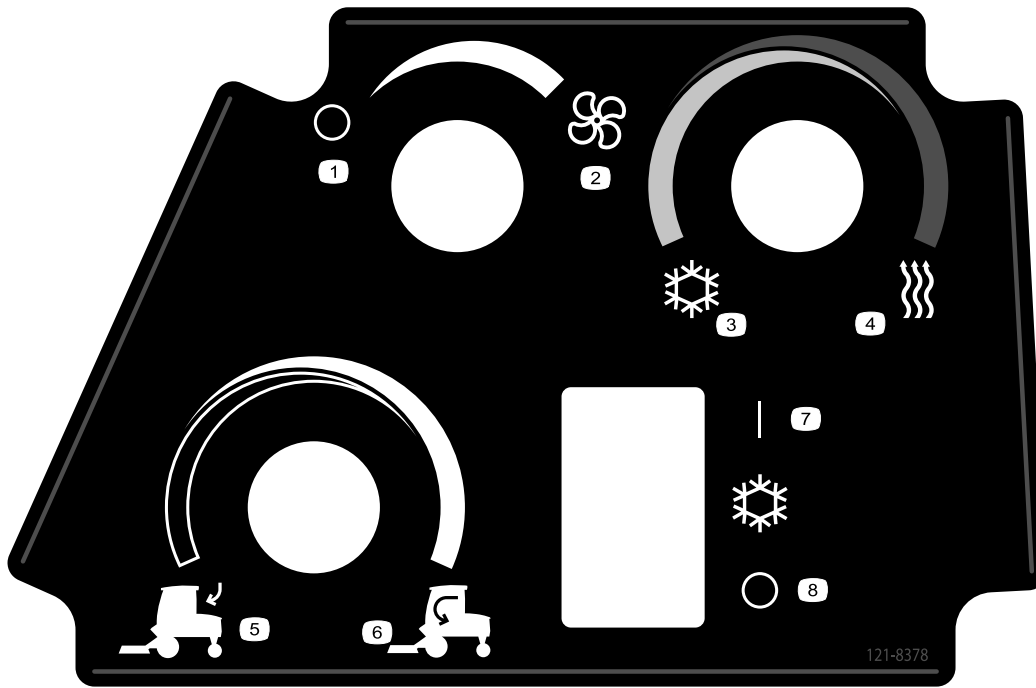

121-8378

decal121-8378

121-8378

Model with Cab Only

- | | | | |
|------------------|-------------|-----------------|--------------------------|
| 1. Fan (off) | 3. Cold air | 5. External air | 7. Air conditioner (off) |
| 2. Fan (on full) | 4. Hot air | 6. Internal air | 8. Air conditioner (on) |

GROUNDSMASTER 4000, MODEL 30605 & 30609 QUICK REFERENCE AID

1

CHECK/SERVICE (DAILY)

1. ENGINE OIL LEVEL	8. AIR CLEANER
2. HYDRAULIC FLUID LEVEL	9. BRAKE FUNCTION
3. ENGINE COOLANT LEVEL	10. INTERLOCK SYSTEM
4. FUEL - DIESEL ONLY	11. TIRE PRESSURE - 25 PSI/1.70 BAR
5. FUEL/WATER SEPARATOR	12. GREASE POINTS (6)
6. FAN BELT TENSION	SEE OPERATOR'S MANUAL FOR 50 HR INTERVAL GREASE POINTS.
7. RADIATOR SCREEN	

SPECIFICATIONS/CHANGE INTERVALS

SEE OPERATOR'S MANUAL FOR INITIAL CHANGES.	FLUID TYPE		CAPACITY	CHANGE INTERVAL		FILTER PART NO.
				FLUID	FILTER	
ENGINE OIL	30605	15W-40, CH4	6 QUARTS	250 HOURS	250 HOURS	125-7025 (A)
	30609	15W-40, CH4				75-1310 (B)
HYDRAULIC FLUID	ISO VG 46/68		7.75 GALLONS	800 HOURS	800 HOURS	94-2621 (C)
HYDRAULIC BREATHER					800 HRS/YRLY	115-9793 (D)
PRIMARY AIR FILTER					SEE SERVICE PUBLICATIONS	108-3814 (E)
SAFETY AIR FILTER					SEE OPERATOR'S MANUAL	108-3816 (F)
FUEL SYSTEM	> 32 F	NO. 2 DIESEL	21 GALLONS	800 HOURS DRAIN/FLUSH	400 HOURS/YEARLY	30605 110-9049 (G)
	< 32 F	NO. 1 DIESEL				30609 125-2915 (H)
REAR AXLE	85W-140		80 OUNCES	800 HOURS		110-4812 BREATHER (I)
PLANETARY DRIVE	85W-140		22 OUNCES	800 HOURS		
ENGINE COOLANT	50% WATER 50% ETHYLENE GLYCOL		9 QUARTS	DRAIN & FLUSH EVERY 2 YRS.		

130-6043

decal130-6043

130-6043

1. Read the *Operator's Manual*.

GROUNDMASTER 4010, MODEL 30635 & 30636 QUICK REFERENCE AID

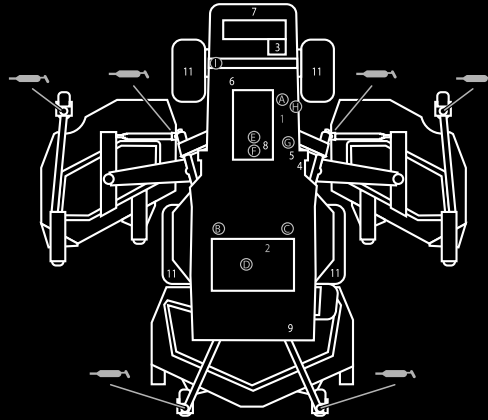

CHECK/SERVICE (DAILY)

- | | |
|--------------------------|-------------------------------------|
| 1. ENGINE OIL LEVEL | 8. AIR CLEANER |
| 2. HYDRAULIC FLUID LEVEL | 9. BRAKE FUNCTION |
| 3. ENGINE COOLANT LEVEL | 10. INTERLOCK SYSTEM |
| 4. FUEL - DIESEL ONLY | 11. TIRE PRESSURE - 25 PSI/1.70 BAR |
| 5. FUEL/WATER SEPARATOR | 12. GREASE POINTS (6) |
| 6. FAN BELT TENSION | SEE OPERATOR'S MANUAL FOR |
| 7. RADIATOR SCREEN | 50 HR INTERVAL GREASE POINTS. |



SPECIFICATIONS/CHANGE INTERVALS

SEE OPERATOR'S MANUAL FOR INITIAL CHANGES.	FLUID TYPE		CAPACITY	CHANGE INTERVAL		FILTER PART NO.	
				FLUID	FILTER		
ENGINE OIL	30635	15W-40, CH-4	6 QUARTS	250 HOURS	250 HOURS	125-7025 (A)	
	30636	15W-40, CH-4				75-1310 (B)	
HYDRAULIC FLUID	ISO VG 46/68		7.75 GALLONS	800 HOURS	800 HOURS	94-2621 (C)	
HYDRAULIC BREATHER					800 HRS/YRLY	115-9793 (D)	
PRIMARY AIR FILTER					SEE SERVICE INDICATOR	108-3814 (E)	
SAFETY AIR FILTER					SEE OPERATOR'S MANUAL	108-3816 (F)	
FUEL SYSTEM	> 32 F	NO. 2 DIESEL	21 GALLONS	800 HOURS DRAIN/FLUSH	400 HOURS/ YEARLY	30635	110-9049 (G)
	< 32 F	NO. 1 DIESEL				30636	125-2915 (H)
REAR AXLE	85W-140		80 OUNCES	800 HOURS		110-4812 BREATHER (I)	
PLANETARY DRIVE	85W-140		22 OUNCES	800 HOURS			
ENGINE COOLANT	50% WATER 50% ETHYL GLYCOL		14.5 QUARTS	DRAIN & FLUSH EVERY 2 YRS.			

130-6046

130-6046

decal130-6046

1. Read the *Operator's Manual*.

Setup

Loose Parts

Use the chart below to verify that all parts have been shipped.

Procedure	Description	Qty.	Use
1	No parts required	–	Grease the machine.
2	Warning decal	1	Replace the warning decal.

Media and Additional Parts

Description	Qty.	Use
Operator's Manual	1	Review before operating the machine.
Engine owner's manual	1	Use to reference engine information.
Parts Catalog	1	Use to reference part numbers.
Operator training materials	1	Review before operating the machine.
Declaration of Conformity	1	

Note: Determine the left and right sides of the machine from the normal operating position.



Greasing the Machine

No Parts Required

Procedure

Before you operate the machine, grease it to ensure proper lubricating characteristics; refer to [Greasing the Bearings and Bushings \(page 45\)](#). Failure to properly grease the machine will result in premature failure of critical parts.



Replacing the Warning Decal

Parts needed for this procedure:

1	<i>Warning decal</i>
---	----------------------

Procedure

On machines requiring European CE compliance, replace the warning decal Part No. 117-2754 with the warning decal Part No. 117-2766.

Product Overview

Controls

Note: Determine the left and right sides of the machine from the normal operating position.

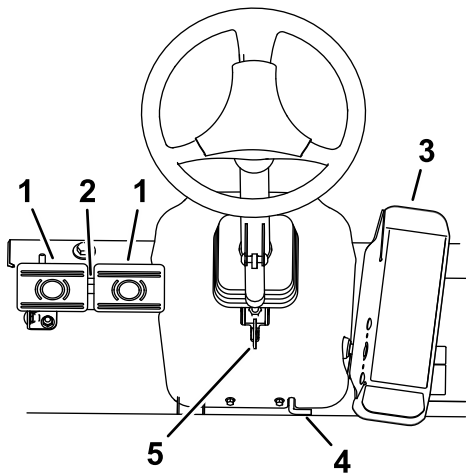

Figure 3

g203048

- | | |
|------------------------|------------------------|
| 1. Brake pedal | 4. Parking-brake latch |
| 2. Pedal-locking latch | 5. Tilt-steering lever |
| 3. Traction pedal | |

Traction Pedal

To stop the machine, reduce your foot pressure on the traction pedal and allow it to return to the center position (Figure 3).

Brake Pedals

There are 2 foot pedals that operate individual wheel brakes for turning assistance, parking, and to aid in better side-hill traction. A latch connects the pedals for parking-brake operation and transport (Figure 3).

Pedal-Locking Latch

The pedal-locking latch connects the pedals together to engage the parking brake (Figure 3).

Tilt-Steering Lever

Press the tilt-steering lever down to tilt the steering wheel to the desired position, then release the lever to lock the adjustment (Figure 3).

Parking-Brake Latch

To engage the parking brake, connect the pedals with the locking latch, push down on both pedals, and push down on

the parking-brake latch while you are pushing on the brake pedals (Figure 3). As you push the pedals, you will feel the latch engage the pedals. To release the parking brake, press both pedals until the parking-brake latch releases.

Hazard-Light Switch

Press the hazard-light switch to activate the hazard lights (Figure 3).

Turn-Signal Switch

Press the left side of the turn-signal switch to activate the left-turn signal and the right side of the switch to activate the right-turn signal (Figure 3).

Key Switch

The key switch (Figure 4) has 3 positions: OFF, ON/PREHEAT, and START.

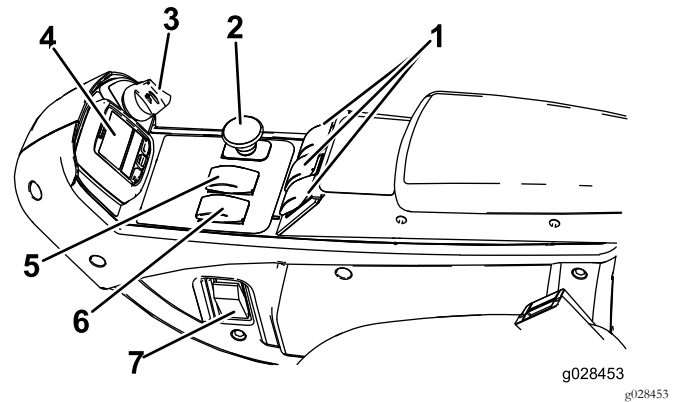

Figure 4

g028453

g028453

- | | |
|------------------|----------------------------|
| 1. Lift switches | 5. Hi—Lo speed control |
| 2. PTO switch | 6. Engine-speed switch |
| 3. Key switch | 7. Light switch (optional) |
| 4. InfoCenter | |

Engine-Speed Switch

The engine-speed switch has 2 modes to change the engine speed (Figure 4).

By momentarily tapping the switch, the engine speed can be increased or decreased in 100-rpm increments. By holding the switch down the engine will automatically move to HIGH or LOW IDLE, depending on which switch is depressed.

PTO Switch

The PTO switch has 2 positions: OUT (START) and IN (STOP). Pull the PTO button out to engage the mower-deck blades. Push the button in to disengage the mower-deck blades (Figure 4).

High—Low Speed-Control Switch

The Hi-Lo speed-control switch allows the speed range to increase for transport of the machine (Figure 4).

Mower decks do not operate in high range. To switch between the HIGH and LOW range, raise the decks, disengage the PTO and the cruise control, move the traction pedal in the NEUTRAL position, and have the machine move at a slow speed.

Lift Switches

The lift switches raise and lower the mower decks (Figure 4). Press the switches forward to lower the mower decks and rearward to raise the mower decks. When starting the machine, with the mower decks in the down position, press the lift switch down to allow the mower decks to float and mow.

Note: The decks do not lower while in the high-speed range and they do not raise or lower if you are out of the seat while the engine is running. Also, the decks lower with the key in the ON position and you are in the seat.

Cruise-Control Switch

The cruise-control switch locks in the pedal position to maintain the desired ground speed (Figure 5). Pressing the rear of the switch turns off the cruise control, the middle position of the switch enables the cruise-control function, and the front of the switch sets the desired ground speed.

Note: Pressing either brake pedal or moving the traction pedal into the reverse position, for 1 second, also disengages the pedal position.

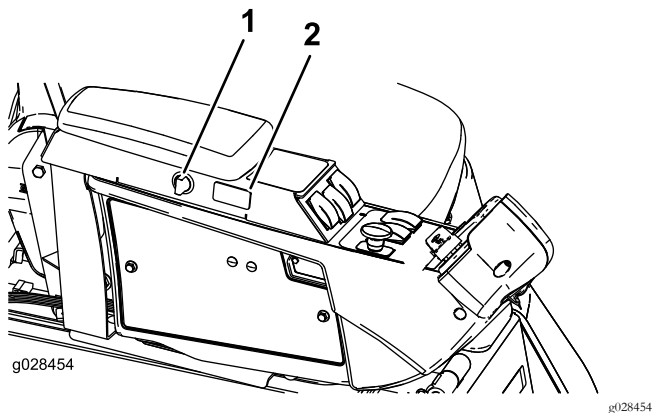

Figure 5

1. Power-point switch
2. Cruise-control switch

Power-Point Switch

Use the power-point switch to power optional electrical accessories (Figure 5).

Seat Adjustments

Seat-Adjustment Lever

Move the seat-adjustment lever on the side of the seat outward, slide the seat to the desired position, and release the lever to lock the seat into position (Figure 6).

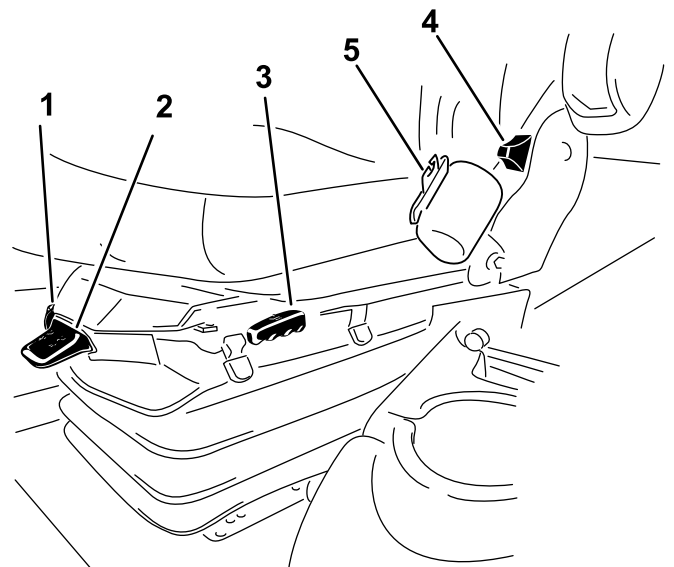

Figure 6

1. Weight gauge
2. Weight-adjustment lever
3. Seat-adjustment lever
4. Seat-back adjustment lever
5. Seat belt

Armrest-Adjustment Knob

Rotate the knob to adjust the armrest angle (Figure 6).

Seat-Back-Adjustment Lever

Move the lever to adjust the seat-back angle (Figure 6).

Weight Gauge

The weight gauge indicates when the seat is adjusted to the weight of the operator (Figure 6). Adjust the height by positioning the suspension within the range of the green region.

Weight-Adjustment Lever

Use this lever to adjust to the proper weight of the operator (Figure 6). Pull up the lever to increase the air pressure and push down to decrease the air pressure. The proper adjustment is correct when the weight gauge is in the green region.

Cab Controls

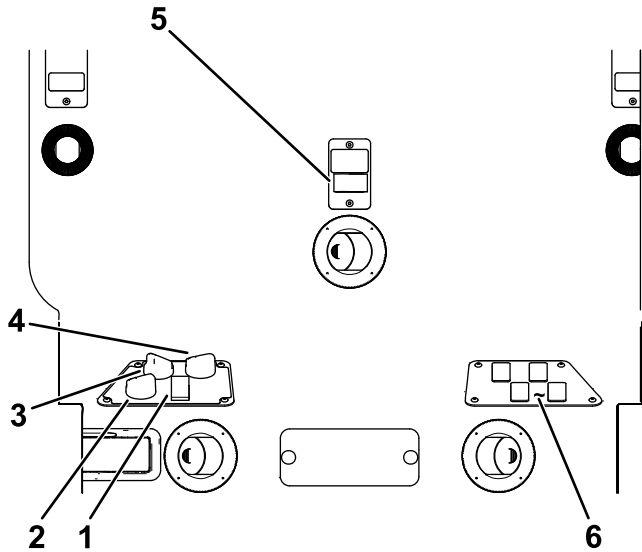

Figure 7

- | | |
|------------------------------|-------------------------------------|
| 1. Air-conditioning switch | 4. Temperature control |
| 2. Air-recirculation control | 5. Windshield-wiper switch |
| 3. Fan control | 6. Blank switches for optional kits |

G032672
g132672

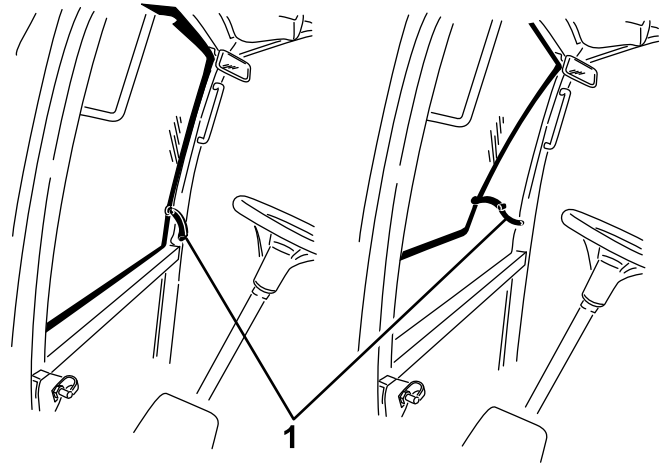

Figure 8

1. Windshield latch

g196911

Rear Window Latch

Lift up the latches to open the rear window. Press in the latch to lock the window open. Pull out and down on the latch to close and secure the window (Figure 8).

Important: You must close the rear window before you open the hood; otherwise, damage may occur.

Air-Recirculation Control

The air-recirculation control sets the cab to either recirculate the air in the cabin or to draw air into the cabin from outside (Figure 7).

- Set it to recirculate the air when using the air-conditioning.
- Set it to draw air in when using the heater or fan.

Fan Control

Rotate the fan control knob to regulate the speed of the fan (Figure 7).

Temperature Control

Rotate the temperature control knob to regulate the air temperature in the cab (Figure 7).

Windshield-Wiper Switch

Use this switch to turn the windshield wipers on or off (Figure 7).

Air Conditioning Switch

Use this switch to turn the air conditioning on or off (Figure 7).

Windshield Latch

Lift up the latches to open the windshield (Figure 8). Press in the latch to lock the windshield open. Pull out and down on the latch to close and secure the windshield.

Using the InfoCenter Control

The InfoCenter LCD display shows information about your machine, such as the operating status, various diagnostics and other information about the machine (Figure 9). There is a splash screen and main information screen of the InfoCenter. You can switch between the splash screen and main information screen at any time by pressing any of the InfoCenter buttons and then selecting the appropriate directional arrow.

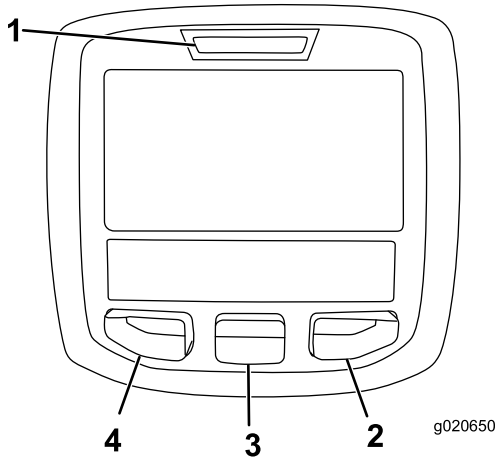

Figure 9

- 1. Indicator light
- 2. Right button
- 3. Middle button
- 4. Left button















- Left Button, Menu Access/Back Button—press this button to access the InfoCenter menus. You can use it to exit any menu that you are currently using.
- Middle Button—use this button to scroll down menus.
- Right Button—use this button to open a menu where a right arrow indicates additional content.
- Beeper—activated when lowering the decks or for advisories and faults.

Note: The purpose of each button may change depending on what is required at the time. Each button is labeled with an icon displaying its current function.







InfoCenter Icon Description

SERVICE DUE	Indicates when scheduled service should be performed
	Engine rpm/status—indicates the engine rpm
	Hour meter
	Info icon
	Sets the maximum traction speed
	Fast
	Slow
	Fan Reversal—indicates when the fan is reversed
	Fuel level
	Stationary regeneration required
	Air intake heater is active
	Raise the left deck
	Raise the center deck
	Raise the right deck
	Operator must sit in seat
	Parking Brake Indicator—indicates when the parking brake is on
	Identifies the range as High
	Neutral
	Identifies the range as Low
	Coolant Temperature—indicates the engine coolant temperature in either °C or °F
	Temperature (hot)
	Traction or Traction Pedal

InfoCenter Icon Description (cont'd.)

	Denied or not allowed
	Engine Start
	PTO—indicates that the PTO is on
	Stop or shutdown
	Engine
	Key switch
	Indicates when the mower decks are being lowered
	Indicates when the mower decks are being raised
	PIN passcode
	Hydraulic-Oil Temperature—indicates the hydraulic-oil temperature
CAN	CAN bus
	InfoCenter
Bad	Bad or failed
Ctr	Center
Rht	Right
Left	Left
	Bulb
OUT	Output of TEC controller or control wire in harness
HI	High: over-allowed range
LO	Low: under-allowed range
HI / LO	Out of range
	Switch
	Operator must release the switch

InfoCenter Icon Description (cont'd.)

	Operator should change to the indicated state
Symbols are often combined to form sentences. Some examples are shown below	
	Operator should put the machine in neutral
	Engine start denied
	Engine shutdown
	Engine coolant is too hot
	Hydraulic fluid is too hot
	Sit down or engage the parking brake

Using the Menus

To access the InfoCenter menu system, press the menu access button while at the main screen. This will bring you to the main menu. Refer to the following tables for a synopsis of the options available from the menus:

Main Menu	
Menu Item	Description
Faults	The Faults menu contains a list of the recent machine faults. Refer to the Service Manual or your Authorized Toro Distributor for more information on the Faults menu and the information contained there.
Service	The Service menu contains information on the machine such as hours of use and other similar numbers.
Diagnostics	The Diagnostics menu displays the state of each machine switch, sensor and control output. You can use this to troubleshoot certain issues as it will quickly tell you which machine controls are on and which are off.

Settings	The Settings menu allows you to customize and modify configuration variables on the InfoCenter display.
About	The About menu lists the model number, serial number, and software version of your machine.

Service	
Menu Item	Description
Hours	Lists the total number of hours that the machine, engine and fan have been on, as well as the number of hours that the machine has been transported and overheated
Counts	Lists the number of preheats and starts that the machine has experienced

Diagnostics	
Menu Item	Description
Engine Run	Refer to the Service Manual or your Authorized Toro Distributor for more information on the Engine Run menu and the information contained there.
Glowplugs	Indicates if the following items are active: Key start, timeout limited, and glowplugs
Fan	Indicates if the fan is active in the following instances: Engine high temp, oil high temp, engine or hydraulic high temp, and fan on

Settings	
Menu Item	Description
Units	Controls the units used on the InfoCenter; the menu choices are English or Metric
Language	Controls the language used on the InfoCenter*
LCD Backlight	Controls the brightness of the LCD display
LCD Contrast	Controls the contrast of the LCD display
Protected Menus	Allows the distributor/engineer to access protected menus by inputting a passcode
Auto Idle	Controls the amount of time allowed before idling the engine when the machine is not in use
Mow Speed	Controls the maximum speed while in mow (low range)

Trans Speed	Controls the maximum speed while in transport (high range)
Smart Power	Smart Power prevents bogging down in heavy turf by automatically controlling the machine speed and optimizing cutting performance.

*Only "operator-faced" text is translated. Faults, Service, and Diagnostics screens are "service-faced." Titles will be in the selected language, but menu items are in English.

About	
Menu Item	Description
Model	Lists the model number of the machine
SN	Lists the serial number of the machine
Machine Controller Revision	Lists the software revision of the master controller
InfoCenter Revision	Lists the software revision of the InfoCenter
CAN Bus	Lists the machine communication bus status

Protected Menus

There are 4 operating configuration settings that are adjustable within the Settings Menu of the InfoCenter: auto idle time delay, maximum mowing ground speed, maximum transport ground speed, and Smart Power. These settings are in the Protected Menu.

Accessing the Protected Menu Settings

To access the Protected Menu Settings, do the following:

- From the Main Menu, scroll down to the Settings Menu and press the right button.
- In the Settings Menu, scroll down to the Protected Menu and press the right button.
- To enter the passcode, use the center button to set the first digit, then press the right button to move on to the next digit.
- Use the center button to set the second digit, then press the right button to move on to the next digit.
- Use the center button to set the third digit, then press the right button to move on to the next digit.
- Use the center button to set the fourth digit, then press the right button.
- Press the middle button to enter the code.

You can change the ability to view and change the settings in the Protected Menu. Go to the Protected Menu and scroll down to Protect Settings. Using the right button, changing Protect Settings to the OFF position allows you to view and

change the settings in the Protected Menu without entering the passcode. Changing Protect Settings to the ON position hides the protected options and requires entering a passcode to change the setting in the Protected Menu. After you have set the passcode, you must turn the key switch off and then on to enable and save this feature.

Setting the Auto Idle

- In the Settings Menu, scroll down to Auto Idle.
- Press the right button to change the auto idle time between Off, 8S, 10S, 15S, 20S, and 30S.

Setting the Maximum Allowed Mow Speed

- In the Settings Menu, Scroll down to Mow Speed and press the right button.
- Use the right button to increase the max full mow speed (50%, 75%, or 100%).
- Use the center button to decrease the max full mow speed (50%, 75%, or 100%).
- Press the left button to exit.

Setting the Maximum Allowed Transport Speed

- In the Settings Menu, scroll down to Transport Speed and press the right button.
- Use the right button to increase the max transport speed (50%, 75%, or 100%).
- Use the center button to decrease the max transport speed (50%, 75%, or 100%).
- Press the left button to exit.

When finished with the Protected Menu, press the left button to exit to the Main Menu, then press the left button to exit to the Run Menu.

Stationary Regeneration

If the Stationary Regeneration icon appears on the InfoCenter, refer to the *Service Manual* or contact your Toro Distributor for the maintenance procedure.

Specifications

Note: Specifications and design are subject to change without notice.

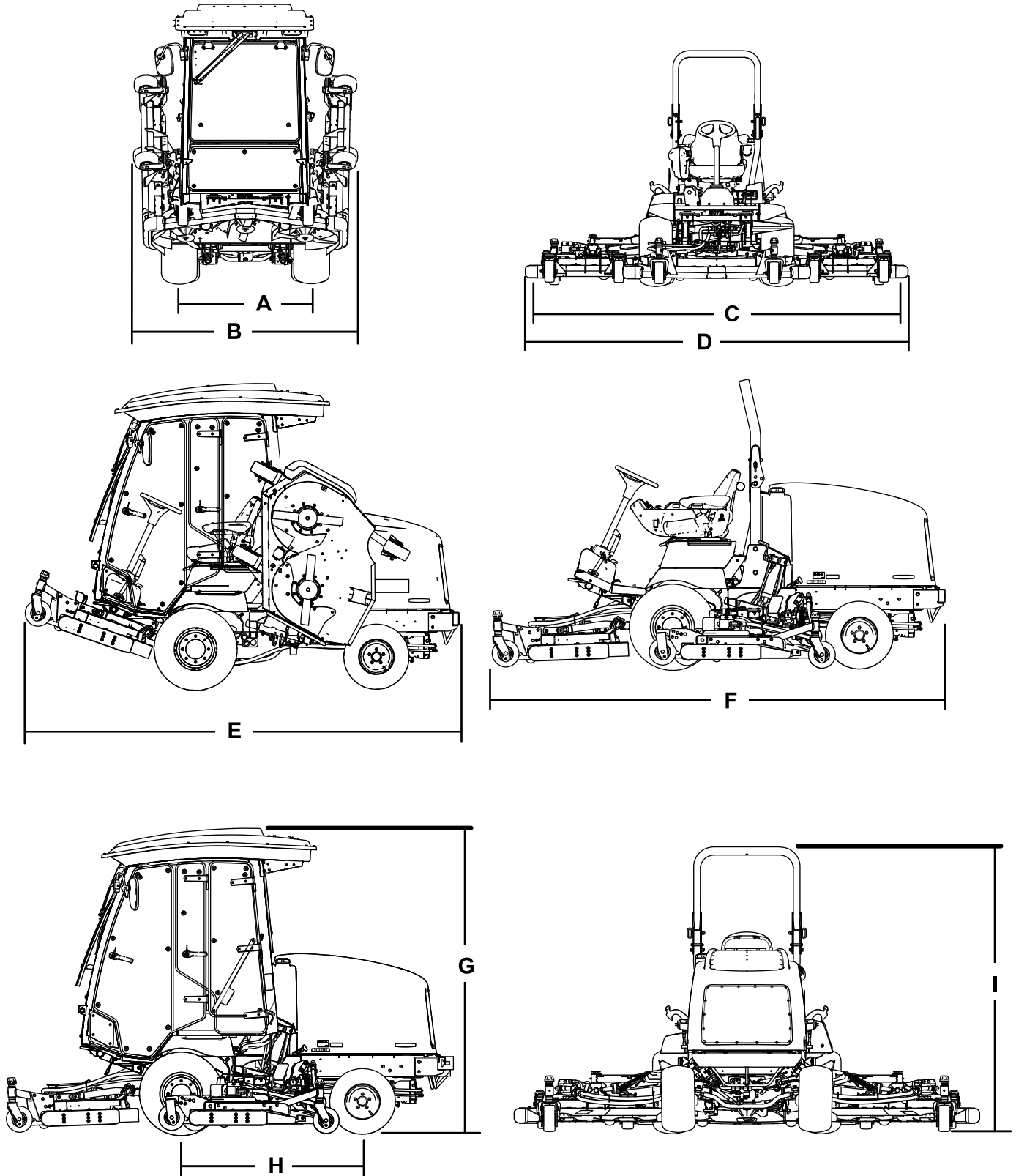

Figure 10

g197050

Description	Figure 10 reference	Dimension or Weight	
Height with cab	G	237 cm (93-1/2 inches)	
Height with roll bar	I	218 cm (86 inches)	
Overall length	F	342 cm (135 inches)	
Length for storage or transport	E	338 cm (133 inches)	
Width of cut			
	overall	C	335 cm (132 inches)
	front cutting unit		157 cm (62 inches)
	side cutting unit		107 cm (42 inches)
	front and one side cutting unit		246 cm (97 inches)
Overall width			
	cutting units down	D	345 cm (136 inches)
	cutting units up (transport position)	B	183 cm (73 inches)
Wheel base	H	141 cm (55-1/2 inches)	
Wheel tread (tire center to center)			
	front	A	114 cm (45 inches)
	rear	J	107 cm (42 inches)
Ground clearance		17 cm (6-1/2 inches)	
Net weight with cab		2159 kg (4,759 lb)	
Net weight with roll bar		2159 kg (4,759 lb)	

Attachments/Accessories

A selection of Toro approved attachments and accessories is available for use with the machine to enhance and expand its capabilities. Contact your Authorized Service Dealer or Distributor or go to www.Toro.com for a list of all approved attachments and accessories.

Operation

Note: Determine the left and right sides of the machine from the normal operating position.

Before Operation

Before Operation Safety

General Safety

- Never allow children or untrained people to operate or service the machine. Local regulations may restrict the age of the operator. The owner is responsible for training all operators and mechanics.
- Become familiar with the safe operation of the equipment, operator controls, and safety signs.
- Know how to stop the machine and engine quickly.
- Check that operator-presence controls, safety switches, and shields are attached and functioning properly. Do not operate the machine unless they are functioning properly.
- Before mowing, always inspect the machine to ensure that the blades, blade bolts, and cutting assemblies are in good

working condition. Replace worn or damaged blades and bolts in sets to preserve balance.

- Inspect the area where you will use the machine and remove all objects that the machine could throw.

Fuel Safety

- Use extreme care in handling fuel. It is flammable and its vapors are explosive.
- Extinguish all cigarettes, cigars, pipes, and other sources of ignition.
- Use only an approved fuel container.
- Never remove the fuel cap or fill the fuel tank while the engine is running or hot.
- Never refuel the machine in an enclosed space.
- Never store the machine or fuel container where there is an open flame, spark, or pilot light, such as on a water heater or other appliance.
- If you spill fuel, do not attempt to start the engine; avoid creating any source of ignition until the fuel vapors have dissipated.

Checking the Engine-Oil Level

Before you start the engine and use the machine, check the oil level in the engine crankcase; refer to [Checking the Engine-Oil Level \(page 47\)](#).

Checking the Cooling System

Before you start the engine and use the machine, check the cooling system; refer to [Checking the Cooling System \(page 24\)](#).

Checking the Hydraulic System

Before you start the engine and use the machine, check the hydraulic system; refer to [Checking the Hydraulic Fluid \(page 59\)](#).

Filling the Fuel Tank

Recommended Fuel

Use only clean, fresh diesel fuel or biodiesel fuels with low or ultra-low (<15 ppm) sulfur content. The minimum cetane

rating should be 40. Purchase fuel in quantities that can be used within 180 days to ensure fuel freshness.

Fuel tank capacity: 79 L (21 US gallons)

Use summer-grade diesel fuel (Number 2-D) at temperatures above -7°C (20°F) and winter-grade diesel fuel (Number 1-D or Number 1-D/2-D blend) below -7°C (20°F). Using winter-grade fuel at lower temperatures provides a lower flash point and cold-flow characteristics, which will ease starting and reduce fuel-filter plugging.

Using summer-grade fuel above -7°C (20°F) will contribute toward longer fuel-pump life and increased power compared to winter-grade fuel.

Important: Do not use kerosene or gasoline instead of diesel fuel. Failure to observe this caution will damage the engine.

Biodiesel Ready

This machine can also use a biodiesel blended fuel of up to B20 (20% biodiesel, 80% petrodiesel). The petrodiesel portion should be ultra-low sulfur. Observe the following precautions:

- The biodiesel portion of the fuel must meet specification ASTM D6751 or EN14214.
- The blended fuel composition should meet ASTM D975 or EN590.
- Painted surfaces may be damaged by biodiesel blends.
- Use B5 (biodiesel content of 5%) or lesser blends in cold weather.
- Monitor seals, hoses, and gaskets in contact with fuel as they may degrade over time.
- Fuel-filter plugging may be expected for a time after converting to biodiesel blends.
- Contact your distributor if you wish for more information on biodiesel.

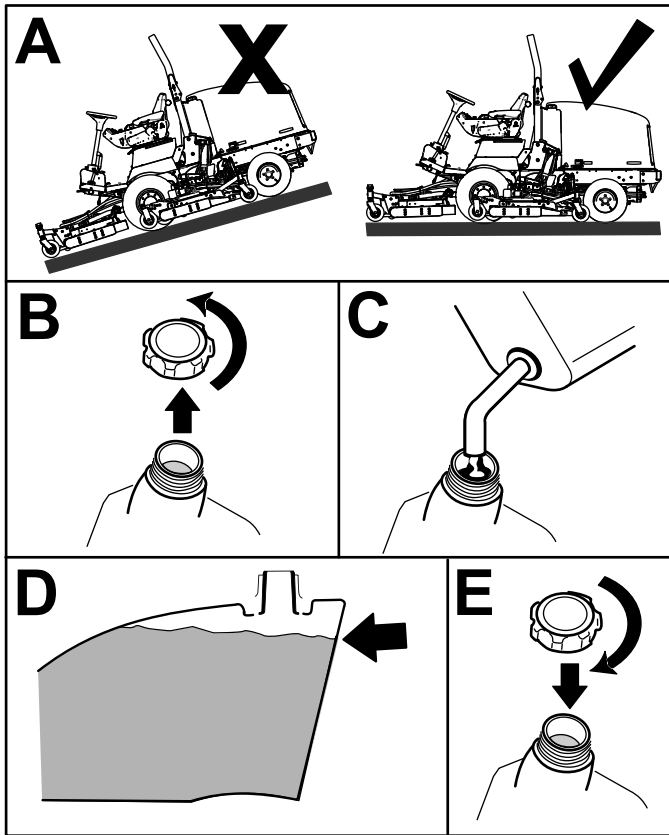

Figure 11

Fill the tank to about 6 to 13 mm (1/4 to 1/2 inch) below the top of the tank, not the filler neck, with Number 2-D diesel fuel.

Note: If possible, fill the fuel tank after each use; this will minimize possible buildup of condensation inside the fuel tank.

Checking the Tire Pressure

Service Interval: Before each use or daily

⚠ DANGER

Low tire pressure decreases machine side-hill stability. This could cause a rollover, which may result in personal injury or death.

Do not underinflate the tires.

The correct air pressure in the tires is 172 to 207 kPa (25 to 30 psi).

Important: Maintain the recommended pressure in all tires to ensure a good quality of cut and proper machine performance. Do not under-inflate the tires.

Check the air pressure in all the tires before operating the machine.

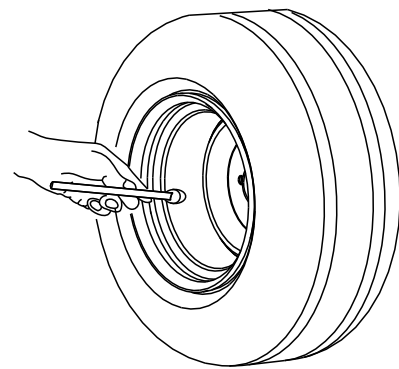

G001055

Figure 12

g001055

Checking the Torque of the Wheel-Lug Nuts

Service Interval: After the first hour

After the first 10 hours

Every 200 hours

Torque the wheel-lug nuts to 115 to 136 N·m (85 to 100 ft-lb) in the order shown in [Figure 13](#) and [Figure 14](#).

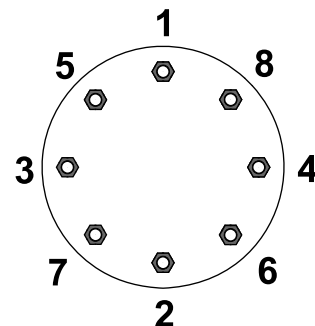

G033358

Figure 13
Front Wheels

g033358

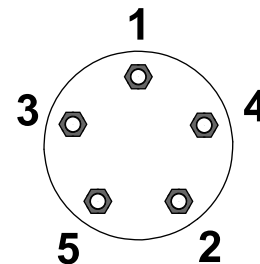

G033359

Figure 14
Rear Wheels

g033359

⚠ WARNING

Failing to maintain proper torque of the wheel-lug nuts could result in personal injury.

Torque the wheel-lug nuts to the proper torque value.

Checking the Planetary-Gear-Drive Oil

Service Interval: Every 400 hours (check if you notice external leakage).

Every 400 hours

Use high quality SAE 85W-140 gear lube as a replacement.

1. With machine on level surface, position the wheel so 1 check plug is at the 12 o'clock position and the other is at 3 o'clock position (Figure 15).

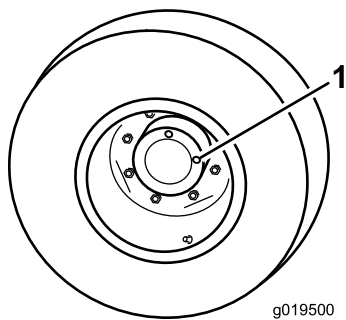

Figure 15

1. Check/drain plug (2)
2. Remove the plug at the 3 o'clock position (Figure 15).
Note: The oil level should be at the bottom of the check-plug hole.
3. If the oil level is low, remove the plug at the 12 o'clock position and add oil until it begins to flow out of the hole at the 3 o'clock position.
4. Install both plugs.

Checking the Rear-Axle Lubricant

Service Interval: Every 400 hours

The rear axle is filled with SAE 85W-140 gear lube. The capacity is 2.4 L (80 fl oz). Visually inspect for leaks daily.

1. Position the machine on a level surface.
2. Remove a check plug from 1 end of the axle and ensure that the lubricant is up to the bottom of the hole (Figure 16).

Note: If the level is low, remove the fill plug and add enough lubricant to bring the level up to the bottom of the check-plug holes.

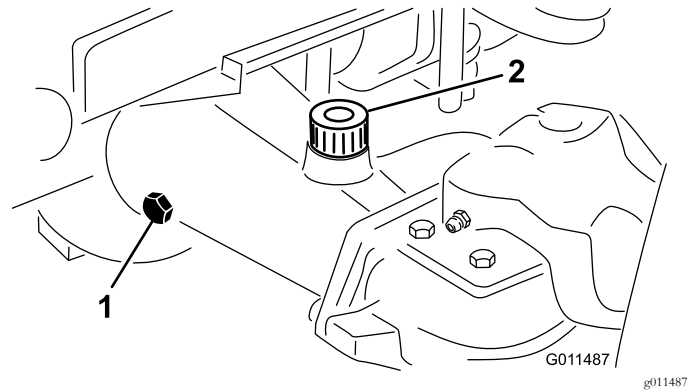

Figure 16

1. Check plug
2. Fill plug

Checking the Rear-Axle-Gearbox Lubricant

Service Interval: Every 400 hours

The gear box is filled with SAE 85W-140 gear lube. The capacity is 0.5 L (16 fl oz). Visually inspect for leaks daily.

1. Position the machine on a level surface.
2. Remove the check/fill plug from the left side of the gear box and ensure that lubricant is up to the bottom of the hole (Figure 17).

Note: If the level is low, add enough lubricant to bring the level up to the bottom of the hole.

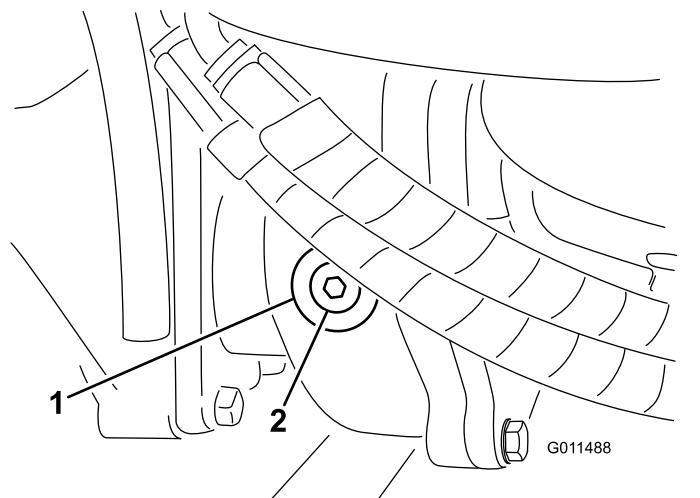

Figure 17

1. Gear box
2. Check/fill plug

Adjusting the Rollover Protection System (ROPS)

⚠ WARNING

To avoid injury or death from rollover: keep the roll bar in the raised locked position and use the seat belt.

Ensure that the seat is secured with the seat latch.

⚠ WARNING

There is no rollover protection when the roll bar is in the down position.

- Do not operate the machine on uneven ground or on a hill side with the roll bar in the down position.
- Lower the roll bar only when absolutely necessary.
- Do not wear the seat belt when the roll bar is in the down position.
- Drive slowly and carefully.
- Raise the roll bar as soon as clearance permits.
- Check carefully for overhead clearances (i.e., branches, doorways, electrical wires) before driving under any objects and do not contact them.

Important: Always use the seat belt when the roll bar is in the raised and locked position. Do not use the seat belt when the roll bar is in the lowered position.

Lowering the Roll Bar

Important: Lower the roll bar only when necessary.

Important: Ensure that the seat is secured with the seat latch.

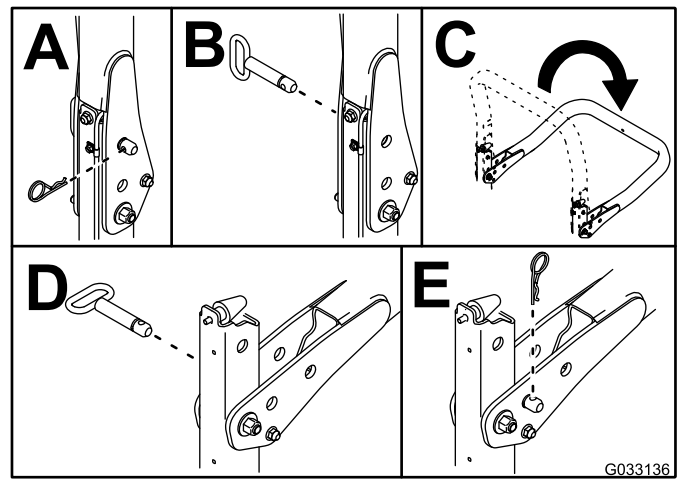

Figure 18

Raising the Roll Bar

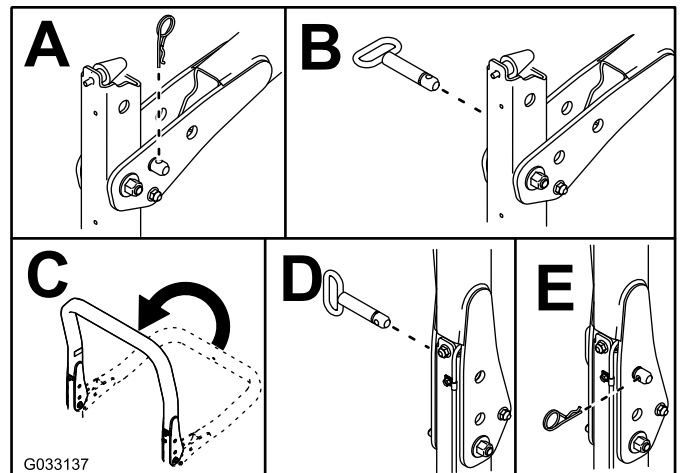

Figure 19

Adjusting the Height of Cut

Front Mower Deck

The height of cut is adjustable from 25 to 127 mm (1 to 5 inches) in 13 mm (1/2 inch) increments. To adjust the height of cut on the front mower deck, position the caster-wheel axles in the upper or lower holes of the caster forks, add or remove an equal number of spacers from the caster forks, and secure the rear chain to the desired hole.

1. Park the machine on a level surface.
2. Start the engine and raise the mower decks to change height of cut.
3. Shut off the engine, engage the parking brake, and remove the key from the switch after the mower deck is raised.

- Position the caster-wheel axles in the same holes in all caster forks.

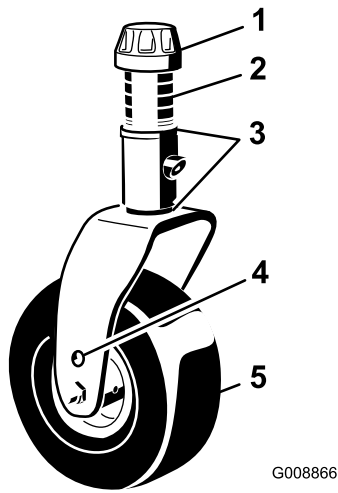

Figure 20

- | | |
|-------------------|---------------------------|
| 1. Tensioning cap | 4. Top axle-mounting hole |
| 2. Spacers | 5. Caster wheel |
| 3. Shims | |

Note: When operating in 64 mm (2-1/2 inch) height of cut or higher, install the axle bolt in the lower caster-fork hole to prevent grass buildup between the wheel and the fork. When operating at heights of cuts lower than 64 mm (2-1/2 inches) and grass buildup is detected, reverse the machines direction to pull any clippings away from the wheel/fork area.

- Remove the tensioning cap from the spindle shaft and slide the spindle out of the caster arm (Figure 20).
- Install 2 shims onto the spindle shaft as they were originally installed.

Note: These shims require a level across the entire width of the mower decks. Slide the appropriate number of 13 mm (1/2 inch) spacers (refer to the chart below) onto the spindle shaft to attain the desired height of cut; then slide the washer onto the shaft.

Refer to the following chart to determine the combinations of spacers for the setting (Figure 21):

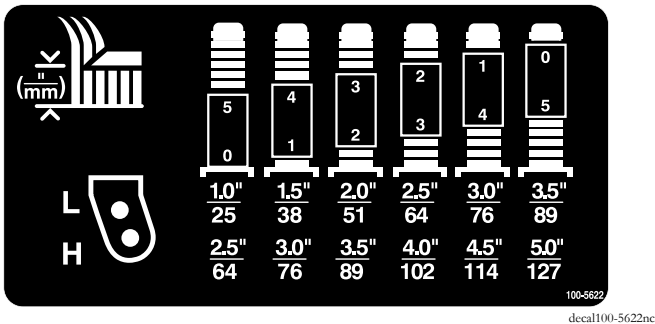

Figure 21

- Push the caster spindle through the front caster arm and install the shims (as they were originally installed) and the remaining spacers onto the spindle shaft.
- Install the tensioning cap to secure the assembly.
- Remove the hairpin cotter and clevis pin securing the height-of-cut chains to the rear of the mower deck (Figure 22).

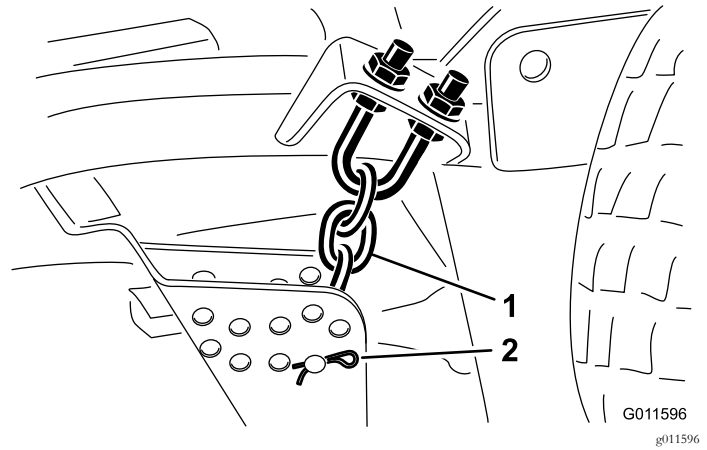

Figure 22

- | | |
|------------------------|----------------------------------|
| 1. Height-of-cut chain | 2. Clevis pin and hairpin cotter |
|------------------------|----------------------------------|

- Mount the height-of-cut chains to the desired height-of-cut hole with the clevis pin and hairpin cotter (Figure 23).

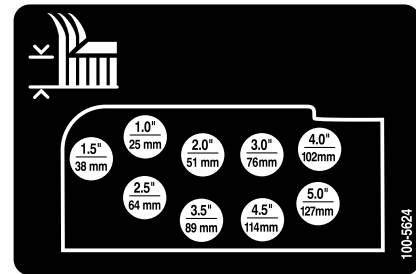

Figure 23

Note: When using 25 mm (1 inch), 38 mm (1-1/2 inches), or 51 mm (2 inches) heights of cut, move the skids and gauge wheels to the highest position.

Side Mower Decks

To adjust the height of cut on the side mower decks, add or remove an equal number of spacers from the caster forks, position the caster-wheel axles in the high or low height-of-cut holes in the caster forks, and secure the pivot arms to the selected height-of-cut bracket holes.

- Position the caster-wheel axles in the same holes in all of the caster forks (Figure 24 and Figure 26).
- Remove the tensioning cap from the spindle shaft and slide the spindle out of the caster arm (Figure 24).

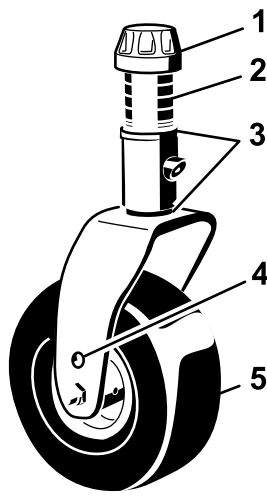

G008866

g008866

Figure 24

1. Tensioning cap
2. Spacers
3. Shims 3 mm (1/8 inch)
4. Top axle-mounting hole
5. Caster wheel

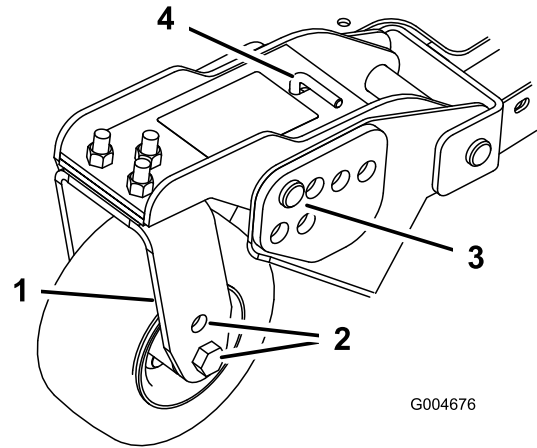

G004676

g004676

Figure 26

1. Caster-pivot arm
2. Axle-mounting holes
3. Clevis pin and hairpin cotter
4. Tension rod

3. Install 2 shims onto the spindle shaft as they were originally installed. These shims are required to achieve a level across the entire width of the mower decks. Slide the appropriate number of 13 mm (1/2 inch) spacers onto the spindle shaft to get the desired height-of-cut; then slide the washer onto the shaft.

Note: These shims require a level across the entire width of the mower decks. Slide the appropriate number of 13 mm (1/2 inch) spacers (refer to the chart below) onto the spindle shaft to attain the desired height of cut; then slide the washer onto the shaft.

Refer to the following chart to determine the combinations of spacers for the setting (Figure 25).

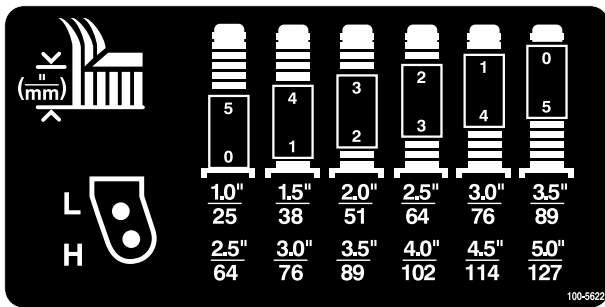

100-5622
decal100-5622nc

Figure 25

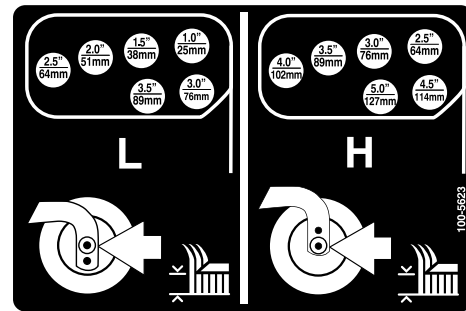

decal100-5623nc

Figure 27

7. Insert the clevis pins and install the hairpin cotters.
8. Rotate the tension rod counterclockwise (finger tight) to put tension on adjustment.
9. Remove the hairpin cotters and clevis pins securing the damper links to the mower-deck brackets (Figure 28).

Important: The damper-link length should never be adjusted. The length between the hole centers should be 13.7 cm (5-3/8 inches).

4. Push the caster spindle through the front caster arm and install the shims (as they were originally installed) and the remaining spacers onto the spindle shaft.
5. Remove the hairpin cotter and clevis pins from the caster-pivot arms (Figure 26).
6. Rotate the tension rod to raise or lower the pivot arm until the holes are aligned with the selected height-of-cut bracket holes in the mower-deck frame (Figure 26 and Figure 27).

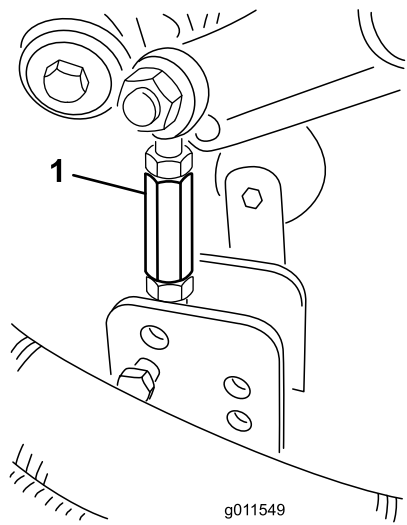

Figure 28

1. Damper link

- Align the damper-link holes with the selected height-of-cut bracket holes in the mower-deck frame, insert the clevis pins, and install the hairpin cotters (Figure 29).

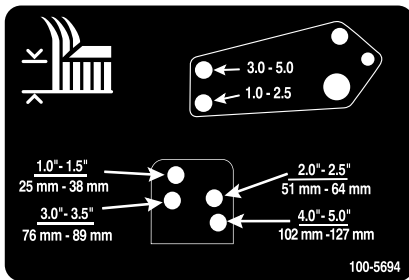

Figure 29

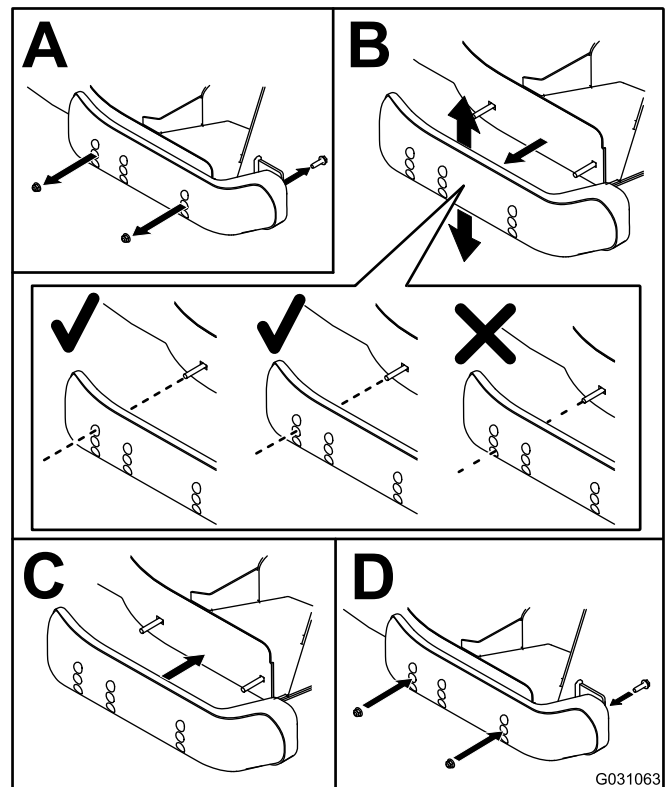

Figure 30

Adjusting the Mower-Deck Rollers

The mower-deck rollers should be mounted in the lower position when operating at height of cuts greater than 64 mm (2-1/2 inches), and in the higher position when operating in height of cuts lower than 64 mm (2-1/2 inches).

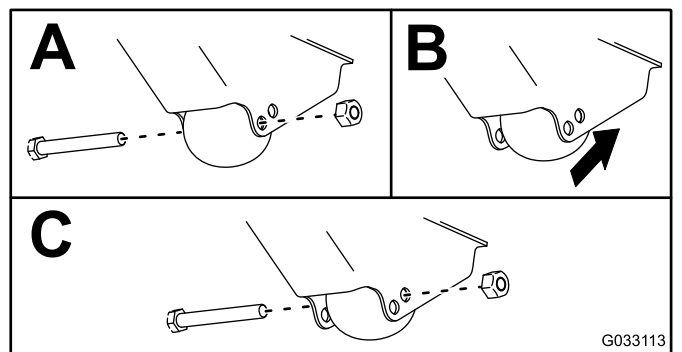

Figure 31

Adjusting the Skids

Mount the skids in the lower position when operating at heights of cut greater than 64 mm (2-1/2 inches) and in the higher position when operating at heights of cut lower than 64 mm (2-1/2 inches).

Note: When the skids become worn, you can switch them to the opposite sides of the mower by flipping them over. This allows you to use the skids longer before replacing them.

Adjust the skids (Figure 30).

Important: Torque the screw at the front of each skid to 9 to 11 N m (80 to 100 in-lb).

Correcting a Mismatch Between the Mower Decks

Due to differences in grass conditions and the counterbalance setting of the traction unit, cut a sample area of grass and check the appearance before cutting the entire area.

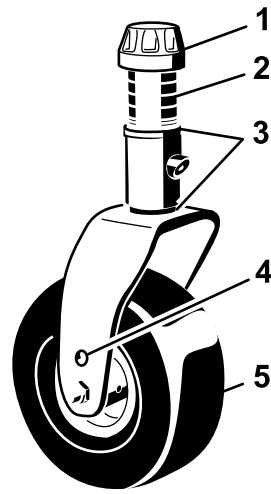

G008866

g008866

Figure 32

- | | |
|-------------------|---------------------------|
| 1. Tensioning cap | 4. Top axle-mounting hole |
| 2. Spacers | 5. Caster wheel |
| 3. Shims | |

1. Set all mower decks to the desired height of cut; refer to [Adjusting the Height of Cut \(page 27\)](#).
 2. Check and adjust the front and rear tire pressures to 172 to 207 kPa (25 to 30 psi).
 3. Check and adjust all of caster tire pressures to 345 kPa (50 psi).
 4. Check the charge and counterbalance pressures with the engine at HIGH IDLE, using hydraulic-test ports.
- Note:** Adjust the counterbalance to 2241 kPa (325 psi).
5. Check for bent blades; refer to [Checking for a Bent Blade \(page 64\)](#).
 6. Cut grass in a test area to determine if all mower decks are cutting at the same height.
 7. If mower-deck adjustments are still needed, find a flat surface using a 2 m (6 ft) or a longer straight edge.
 8. To ease measuring the blade plane, raise the height of cut to 7.6 to 10.1 cm (3 to 4 inches); refer to [Adjusting the Height of Cut \(page 27\)](#).
 9. Lower the mower decks onto a flat surface and remove the covers from the top of the mower decks.
 10. Loosen the flange nut, securing the idler pulley, to release the belt tension on each mower deck.

Front Mower Deck Setup

Rotate the blade on each spindle until the ends face forward and backward. Measure from the floor to the front tip of the cutting edge. Adjust the shims on the front caster fork(s) to match the height-of-cut decal ([Figure 32](#)); refer to [Adjusting the Mower-Deck Pitch \(page 62\)](#).

Side Mower Deck Setup

Rotate the blade of each spindle until the ends face forward and backward. Measure from the floor to the front tip of the cutting edge. Adjust the shims on front caster arm(s) to match the height-of-cut decal ([Figure 33](#)). For the outside blade spindle only, refer to [Adjusting the Mower-Deck Pitch \(page 62\)](#).

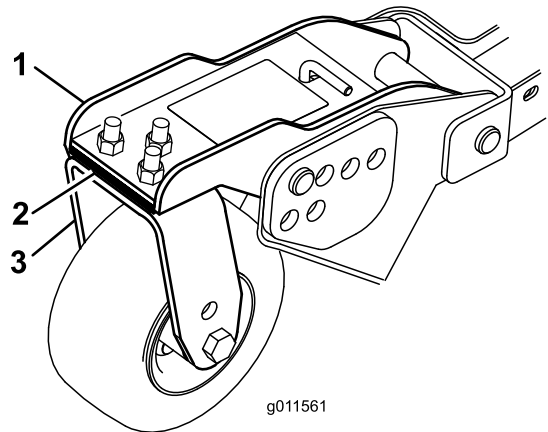

g011561

g011561

Figure 33

- | | |
|---------------------|----------------------|
| 1. Front caster arm | 3. Front caster fork |
| 2. Shims | |

Matching the Height of Cut Between Mower Decks

1. Position the blade side to side on the outside spindle of both side mower decks.

Note: Measure from the floor to the tip of the cutting edge on both units and compare. These numbers

should be within 3 mm (1/8 inch) of each other. Make no adjustment at this time.

2. Position the blade side to side on the inside spindle of the side mower deck and corresponding outside spindle of the front mower deck.

Note: Measure from the floor to the tip of the cutting edge on the inside edge of side mower deck to the corresponding outside edge of front mower deck and compare. The side mower-deck measurement should be within 3 mm (1/8 inch) of the front mower deck.

Note: All 3 mower deck caster wheels should remain on the ground with counterbalance applied.

Note: If adjustments need to be made to match the cut between the front and side mower decks, make the adjustments to the **side mower decks only**.

3. If the inside edge of the side mower deck is too high relative to the outside edge of the front mower deck, remove a shim from the bottom of the front, inside caster arm on the side mower deck (Figure 33).

Note: Check the measurements between the outside edges of both side mower decks and the inside edge of the side mower deck to the outside edge of the front mower deck again.

4. If the inside edge is still too high, remove an additional shim from the bottom of front, inside caster arm of the side mower deck **and** a shim from the front, outside caster arm of the side mower deck.
5. If the inside edge of the side mower deck is too low relative to the outside edge of the front mower deck, add a shim to the bottom of the front, inside caster arm on the side mower deck.

Note: Check the measurement between the outside edges of both side mower decks and the inside edge of the side mower deck to the outside edge of front mower deck again.

6. If the inside edge is still too low, add an additional shim to the bottom of front, inside caster arm of the side mower deck **and** add a shim to the front, outside caster arm of the side mower deck.
7. When the cutting height matches at the edges of front and side mower decks, verify that the side mower-deck pitch is still 8 to 11 mm (5/16 to 7/16 inch).

Note: Adjust as necessary.

Checking the Safety-Interlock Switches

Service Interval: Before each use or daily

The machine has interlock switches in the electrical system. These switches disengage either the traction or the PTO whenever you leave the seat. Although the engine continues to run if you disengage PTO switch, and the you release the traction pedal, shut off the engine before rising from the seat.

To check the operation of the interlock switches, perform the following procedure:

1. Drive the machine slowly to a large, relatively open area. Lower the mower deck, shut off the engine, and apply the parking brake.
2. Sit on the seat and press the traction pedal. Try to start the engine. The engine should not start. If the engine starts, there is a malfunction in the interlock system that should be corrected before beginning operation.
3. Sit on the seat and start the engine. Rise from the seat and move the PTO switch to ON. The PTO should not engage. If the PTO engages, there is a malfunction in the interlock system that should be corrected before beginning operation.
4. Sit on the seat, engage the parking brake and start the engine. Move the traction pedal out of the NEUTRAL position. The InfoCenter should display “traction not allowed” and the machine should not move. If the engine does move, there is a malfunction in the interlock system that should be corrected before beginning operation.

Adjusting the Mirrors Cab Model Only

Rearview Mirror

While sitting in the seat, adjust the rearview mirror to attain the best view out the rear window (Figure 34). Pull the lever rearward to tilt the mirror to reduce the brightness and glare of light.

Side-View Mirrors

While sitting in the seat, have someone assist to adjust the side-view mirrors to attain the best view around the side of the machine (Figure 34).

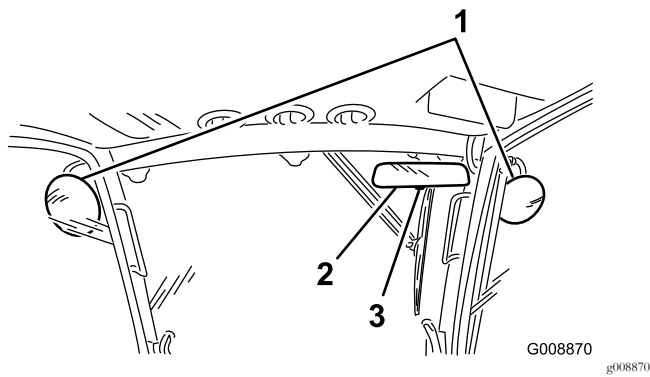

Figure 34

- | | |
|----------------------|----------|
| 1. Side-view mirrors | 3. Lever |
| 2. Rearview mirror | |

Aiming the Headlights

- Loosen the mounting nuts and position each headlight so it points straight ahead.

Note: Tighten the mounting nut just enough to hold the headlight in position.

- Place a flat piece of sheet metal over the face of the headlight.
- Mount a magnetic protractor onto the plate.
- While holding the assembly in place, carefully tilt the headlight downward 3 degrees, then tighten the nut.
- Repeat the procedure on the other headlight.

During Operation

During Operation Safety

General Safety

- The owner/operator can prevent and is responsible for accidents that may cause personal injury or property damage.
- Wear appropriate clothing, including eye protection; slip-resistant, substantial foot protection; and hearing protection. Tie back long hair and do not wear jewelry.
- Do not operate the machine while ill, tired, or under the influence of alcohol or drugs.
- Never carry passengers on the machine and keep bystanders and pets away from the machine during operation.
- Operate the machine only in good visibility to avoid holes or hidden hazards.
- Avoid mowing on wet grass. Reduced traction could cause the machine to slide.
- Before you start the engine, ensure that all drives are in neutral, the parking brake is engaged, and you are in the operating position.

- Keep your hands and feet away from the cutting units. Keep clear of the discharge opening at all times.
- Look behind and down before backing up to be sure of a clear path.
- Use care when approaching blind corners, shrubs, trees, or other objects that may obscure your vision.
- Stop the blades whenever you are not mowing.
- Stop the machine and inspect the blades after striking an object or if there is an abnormal vibration in the machine. Make all necessary repairs before resuming operation.
- Slow down and use caution when making turns and crossing roads and sidewalks with the machine. Always yield the right-of-way.
- Disengage the drive to the cutting unit and shut off the engine before adjusting the height of cut (unless you can adjust it from the operating position).
- Never run an engine in an area where exhaust gasses are enclosed.
- Never leave a running machine unattended.
- Before leaving the operating position (including to empty the catchers or to unclog the chute), do the following:
 - Park the machine on level ground.
 - Disengage the power take-off and lower the attachments.
 - Engage the parking brake.
 - Shut off the engine and remove the key.
 - Wait for all moving parts to stop.
- Do not operate the machine when there is the risk of lightning.
- Do not use the machine as a towing vehicle.
- Use accessories, attachments, and replacement parts approved by The Toro® Company only.

Rollover Protection System (ROPS) Safety

- Do not** remove the ROPS from the machine.
- Ensure that the seat belt is attached and that you can release it quickly in an emergency.
- Check carefully for overhead obstructions and do not contact them.
- Keep the ROPS in safe operating condition by thoroughly inspecting it periodically for damage and keeping all the mounting fasteners tight.
- Replace a damaged ROPS. Do not repair or alter it.

Machines with Cabs

- The ROPS is an integral safety device.
- A cab installed by Toro is a roll bar.
- Always wear your seat belt.

Machines with a Foldable Roll Bar

- Always use the seat belt with the roll bar in the raised position.
- The ROPS is an integral safety device. Keep a folding roll bar in the raised and locked position, and use the seat belt when operating the machine with the roll bar in the raised position.
- Lower a folding roll bar temporarily only when necessary. Do not wear the seat belt when the roll bar is folded down.
- Be aware that there is no rollover protection when a folded roll bar is in the down position.
- Check the area that you will be mowing and never fold down a folding roll bar in areas where there are slopes, drop-offs, or water.

Slope Safety

- Establish your own procedures and rules for operating on slopes. These procedures must include surveying the site to determine which slopes are safe for machine operation. Always use common sense and good judgment when performing this survey.
- Slopes are a major factor related to loss-of-control and tip-over accidents, which can result in severe injury or death. Operating the machine on any slope requires extra caution.
- Operate the machine at a lower speed when you are on a slope.
- If you feel uneasy operating the machine on a slope, do not do it.
- Watch for holes, ruts, bumps, rocks, or other hidden objects. Uneven terrain could overturn the machine. Tall grass can hide obstacles.
- Choose a low ground speed so you will not have to stop or shift while on a slope.
- A rollover can occur before the tires lose traction.
- Avoid operating the machine on wet grass. Tires may lose traction; regardless if the brakes are available and functioning.
- Avoid starting, stopping, or turning the machine on a slope.
- Keep all movement on slopes slow and gradual. Do not suddenly change the speed or direction of the machine.
- Do not operate the machine near drop-offs, ditches, embankments, or bodies of water. The machine could suddenly roll over if a wheel goes over the edge or the edge caves in. Establish a safety area between the machine and any hazard (2 machine widths).

Starting the Engine

Important: The fuel system automatically bleeds itself when any of the following situations occur:

- Initial start up of a new machine.
- The engine has ceased running due to lack of fuel.
- Maintenance has been performed upon the fuel system components.
 1. Remove your foot from the traction pedal and ensure that it is in neutral. Ensure that the parking brake is set.
 2. Move the engine-speed switch to the LOW-IDLE position.
 3. Turn the key to the RUN position.

Note: The glow indicator will light.
 4. When the glow indicator dims, turn the key to the START position. Release the key immediately when the engine starts and allow it to return to the RUN position.

Important: Do not run the starter motor more than 30 seconds at a time or premature starter failure may result. If the engine fails to start after 30 seconds, turn the key to the OFF position, check the controls and procedures, wait 30 additional seconds, and repeat the starting procedure.
 5. Allow the engine to warm up at mid speed (without load), then move the throttle control to the desired position.

Important: Allow the engine to idle for 5 minutes before shutting it off after a full-load operation. Failure to do so may damage the turbocharger.

Shutting Off the Engine

Important: Allow the engine to idle for 5 minutes before shutting it off after a full-load operation. This allows the turbocharger to cool down before shutting the engine off. Failure to do so may damage the turbocharger.

Note: Lower the mower decks to the ground whenever you park the machine. This relieves the hydraulic load from the system, prevents wear on system parts, and also prevents accidental lowering of the mower decks.

1. Move the PTO switch to the OFF position.
2. Engage the parking brake.
3. Move the engine-speed switch to the LOW IDLE position.
4. Rotate the key to the OFF position.
5. Remove the key from the switch to prevent accidental starting.

Understanding Smart Power™ Traction

With Toro Smart Power™ traction, the operator does not have to listen to the engine speed in heavy conditions. Smart Power prevents bogging down in heavy turf by automatically controlling the machine speed and optimizing cutting

performance. You can simply set a maximum ground speed that is comfortable and mow without having to manually reduce the traction speed when mowing in heavy conditions.

Reversing Fan Operation

The fan speed is controlled by the hydraulic-fluid temperature and engine-coolant temperature. A reverse cycle is automatically initiated when either the engine coolant or hydraulic-fluid temperature reaches a certain point. This reversal helps blow debris off the rear screen and lower the engine and hydraulic-fluid temperatures. By simultaneously pressing the right and left buttons on the InfoCenter, the fan completes a manually-initiated reverse cycle. Reverse the fan manually prior to leaving the work area, entering the shop, or storage area.

Understanding Auto Idle

The machine is equipped with auto idle, which automatically idles the engine when all the following functions are not used, for a pre-determined time, previously set in the InfoCenter.

- The traction pedal is returned to the NEUTRAL position.
- The PTO is disengaged.
- None of the lift switches are activated.

When any of the above functions are initiated, the machine automatically returns to the previous throttle position.

Using Cruise Control

The cruise-control switch locks in the pedal position to maintain the desired ground speed. Pressing the rear of the switch turns the cruise control off, the middle position of the switch enables the cruise-control function, and the front of the switch sets the desired ground speed.

Note: Pressing either the brake pedal or moving the traction pedal into the REVERSE position, for 1 second, also disengages the pedal position.

Using the Engine-Speed Switch

The engine-speed switch has 2 modes to change the engine speed. By momentarily tapping the switch, the engine speed increases or decreases in 100-rpm increments. By holding the switch down, the engine automatically moves to HIGH or LOW IDLE, depending on which part of the switch you pressed.

Adjusting the Mowing Speed

Supervisor (Protected Menu)

This feature allows the supervisor to set the maximum mowing speed in increments of 50%, 75% or 100%, at which the operator can mow (low range).

Refer to [Setting the Maximum Allowed Mow Speed \(page 21\)](#) for the procedure to set the mow speed.

Operator

This feature allows the operator to adjust the maximum mowing speed (low range), within the supervisors pre-adjusted settings. When in the InfoCenter splash or main screen, press the middle button ( icon) to adjust the speed.

Note: When switching between low and high ranges, the settings transfer based on the previous setting. The settings are reset when the machine is turned off.

Note: This feature may also be used in conjunction with cruise control.

Adjusting the Transport Speed

Supervisor (Protected Menu)

This feature allows the supervisor to set the maximum transport speed in increments of 50%, 75% or 100%, at which the operator can transport (high range).

Refer to [Using the InfoCenter Control \(page 18\)](#) for the procedure to set the transport speed.

Operator

This feature allows the operator to adjust the maximum transport speed (high range) within the supervisor's pre-adjusted settings. When in the InfoCenter splash or main screen, press the middle button ( icon) to adjust the speed.

Note: When switching between low and high ranges, the settings transfer based on the previous setting. The settings reset when you turn off the machine.

Note: You can also use this feature in conjunction with cruise control.

Understanding the Operating Characteristics of the Machine

Practice driving the machine because it has a hydrostatic transmission and its characteristics are different than many turf-maintenance machines.

With Toro Smart Power™, you do not need to listen to the engine speed in heavy conditions. Smart Power prevents bogging down in heavy turf by automatically controlling the machine speed and optimizing cutting performance.

You can use the brakes to assist in turning the machine, but use them carefully, especially on soft or wet grass because they can damage the turf. You can also use the brakes to maintain traction. For example, in some slope conditions, the uphill wheel slips and loses traction. If this situation occurs, press the uphill turn pedal gradually and intermittently until the uphill wheel stops slipping, thus, increasing traction on the downhill wheel.

Traction Assist is now automatic and requires no operator input. When a wheel starts to slip, flow is automatically split between the front and rear wheels to minimize wheel slip and loss of traction.

Use extra care when operating the machine on slopes. Ensure that the seat latch is properly secured and that you buckle the seat belt. Drive slowly and avoid sharp turns on slopes to prevent roll overs. For steering control, the mower deck must be lowered when going downhill.

Before stopping the engine, disengage all controls and change the throttle to the SLOW position. Changing the throttle to the SLOW position reduces high engine speed, noise, and vibration. Turn the key to the OFF position to shut off the engine.

Before transporting the machine, raise the mower decks and secure the transport latches (Figure 35).

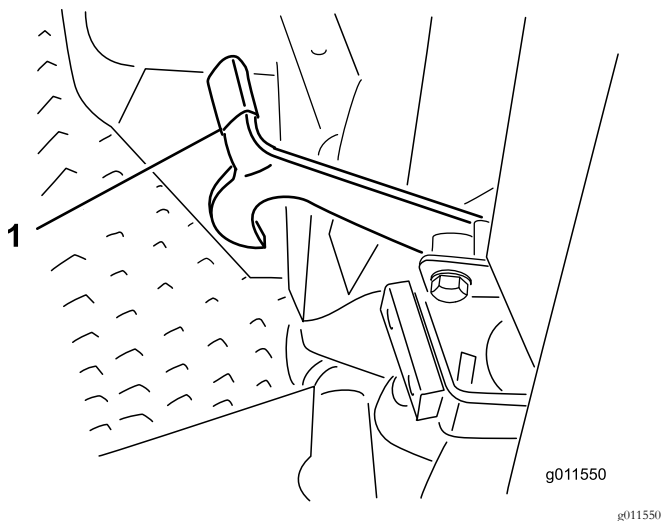

Figure 35

1. Transport latch (side mower decks)

Operating Tips

Operating the Machine

- Start the engine and run it at the HALF IDLE position until it warms up. Push the throttle lever all the way forward, lift the mower decks, disengage the parking brake, press the forward traction pedal, and carefully drive to an open area.

- Practice moving forward and reverse, and starting and stopping the machine. To stop the machine, remove your foot from the traction pedal and let it return to NEUTRAL or press down on the reverse pedal.

Note: When going downhill in the machine, you may need to use the reverse pedal to stop.

- When possible, mow up and down hills rather than across them. Have the mower decks lowered when going down a hill to maintain steering control. Do not attempt to turn the machine on a hill.
- Practice driving around obstacles with the mower decks up and down. Be careful when driving between narrow objects so that you do not damage the machine or mower decks.
- Always drive slowly in rough areas.
- If an obstacle is in the way, lift the mower decks to mow around it.
- When transporting the machine from 1 work area to another, raise the mower decks to the fully upward position, shut off the PTO, press the mow/transport switch to the to the 'TRANSPORT' position, and place the throttle in the FAST position.

Changing Mowing Patterns

Change mowing patterns often to minimize a poor after-cut appearance from repeatedly mowing in the same direction.

Understanding Counterbalance

The counterbalance system maintains hydraulic back pressure on the deck-lift cylinders. This counterbalance pressure transfers mower deck weight to the mower drive wheels to improve traction. The counterbalance pressure has been set at the factory to an optimal balance of after-cut appearance and traction capability in most turf conditions. Decreasing the counterbalance setting can produce a more stable mower deck, but can decrease the traction capability. Increasing the counterbalance setting can increase the traction capability, but may result in a poor after-cut appearance. Refer to the *Service Manual* for your traction unit for instructions to adjust the counterbalance pressure.

Resolving After-Cut Appearance

Reference the After-cut Appearance Troubleshooting Guide available at www.Toro.com.

Using Proper Mowing Techniques

- To begin cutting, engage the mower decks, then approach the mowing area slowly. Once the front mower decks are over the mowing area, lower the mower decks.
- To achieve the professional straight-line cut and striping that is desirable for some applications, find a tree or other object in the distance and drive straight toward it.

- As soon as the front mower decks reach the edge of the mowing area, lift the mower decks, and perform a teardrop-shaped turn to quickly line up for your next pass.
- The mower decks tend to throw grass to the left side of the machine. If you are trimming around bunkers, it is best to mow in a clockwise direction to prevent throwing clippings into the bunker.
- Bolt-in mulching baffles are available for the mower decks. The mulching baffles perform well when you maintain turf on a regular schedule to avoid removing more than 25 mm (1 inch) of growth per cutting. When you cut too much growth with the mulching baffles installed, the after-cut appearance may deteriorate and the observed power to cut the turf increases. The mulching baffles also perform well for shredding leaves in the fall.

Mowing When the Grass Is Dry

Mow either in the late morning to avoid the dew, which causes grass clumping, or late afternoon to avoid the damage that direct sunlight can cause on the sensitive, freshly mowed grass.

Selecting the Proper Height-of-Cut Setting to Suit Conditions

Remove approximately 25 mm (1 inch), or no more than 1/3 of the grass blade when cutting. In exceptionally lush and dense grass, you may need to raise your height-of-cut setting.

Mowing with Sharp Blades

A sharp blade cuts cleanly and without tearing or shredding the grass blades like a dull blade. Tearing and shredding causes the grass to turn brown at the edges, which impairs growth and increases susceptibility to diseases. Ensure that the blade is in good condition and that there is a full sail.

Checking the Condition of the Mower Deck

Ensure that the cutting chambers are in good condition. Straighten any bends in the chamber components to ensure correct blade tip/chamber clearance.

Maintaining the Machine after Mowing

After mowing, thoroughly wash the machine with a garden hose with no nozzle to avoid contamination and damage to the seals and bearings caused by excessive water pressure. Ensure that the radiator and oil cooler are kept free of dirt or grass clippings. After cleaning, inspect the machine for possible hydraulic-fluid leaks, damage, or wear to the hydraulic and mechanical components, and check the mower-deck blades for sharpness.

After Operation

After Operation Safety

- Clean grass and debris from the cutting units, mufflers, and engine compartment to help prevent fires. Clean up oil or fuel spills.
- If the cutting units are in the transport position, use the positive mechanical lock (if available) before you leave the machine unattended.
- Allow the engine to cool before storing the machine in any enclosure.
- Shut off the fuel before storing or transporting the machine.
- Never store the machine or fuel container where there is an open flame, spark, or pilot light, such as on a water heater or on other appliances.
- Keep all parts of the machine in good working condition and all hardware tightened, especially blade-attachment hardware.
- Replace all worn or damaged decals.

Pushing or Towing the Machine

In an emergency, the machine can be moved forward by actuating the bypass valve in the variable-displacement hydraulic pump and pushing or towing the machine.

Important: Do not push or tow the machine faster than 3 to 4.8 km/h (2 to 3 mph), because internal-transmission damage may occur. The bypass valves must be open whenever you push or tow the machine.

1. Raise the seat and locate the bypass valves, which are located below the front of the fuel tank (Figure 36).

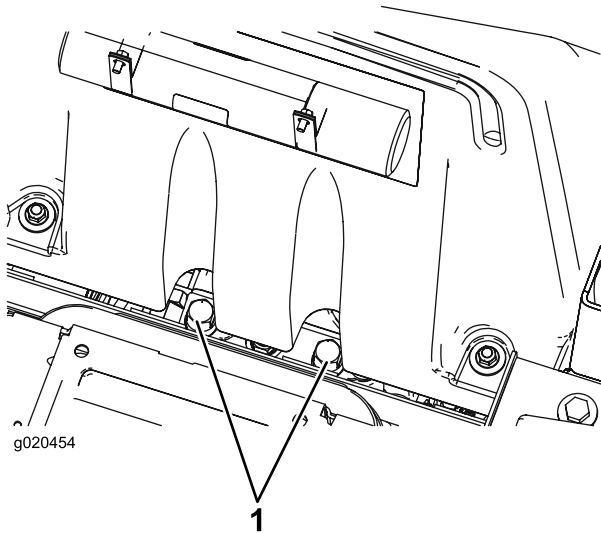

Figure 36

1. Bypass valves (2)
-
2. Rotate each valve 3 turns counter-clockwise to open and allow oil to bypass internally.
- Note:** Do not open more than 3 turns. Because fluid is bypassed, the machine can be slowly moved without damaging the transmission.
3. Close the bypass valves before starting the engine.
 4. Torque to 70 N·m (52 ft-lb) to close the valve.

Important: To push or tow the machine in reverse, you must bypass the check valve in the 4-wheel drive manifold. To bypass the check valve, connect a hose assembly to the reverse traction pressure test port, located on the hydrostat, and on the port located between ports M8 and P2 on the rear traction manifold, which is located behind the front tire. The hose assembly includes 1 hose (Part No. 95-8843), 2 coupler fittings (Part No. 95-0985), and 2 hydraulic fittings (Part No. 340-77).

Locating the Jacking Points

There are jacking points located at the front and rear of the machine.

⚠ DANGER

Mechanical or hydraulic jacks may fail to support machine and cause a serious injury.

- Use jack stands when supporting machine.
- Do not use hydraulic jacks.
- On the frame at the inside of each front drive tire
- At the center of the rear axle

Hauling the Machine

- Use care when loading or unloading the machine into a trailer or a truck.
- Use full-width ramps for loading the machine into a trailer or a truck.
- Tie the machine down securely using straps, chains, cable, or ropes. Both front and rear straps should be directed down and outward from the machine.

Locating the Tie-Down Points

There are tie downs located at the front and rear sides of the machine (Figure 37).

Note: Use properly-rated DOT-approved straps in 4 corners to tie down the machine.

- 2 on the front of the operator's platform
- Rear bumper

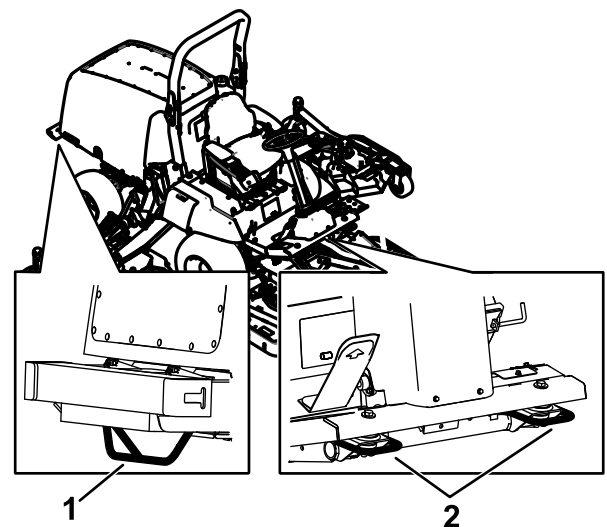

Figure 37

1. Rear tie-down point
2. Front tie-down points

Maintenance

Important: Refer to your engine owner's manual for additional maintenance procedures.

Note: Download a free copy of the electrical or hydraulic schematic by visiting www.Toro.com and searching for your machine from the Manuals link on the home page.

Note: Determine the left and right sides of the machine from the normal operating position.

Recommended Maintenance Schedule(s)

Maintenance Service Interval	Maintenance Procedure
After the first hour	<ul style="list-style-type: none"> • Torque the wheel-lug nuts.
After the first 10 hours	<ul style="list-style-type: none"> • Torque the wheel-lug nuts. • Check the alternator-belt tension. • Check the compressor-belt tension. • Check the blade-drive-belt tension.
After the first 50 hours	<ul style="list-style-type: none"> • Change the engine oil and filter.
After the first 200 hours	<ul style="list-style-type: none"> • Change the front planetary-gear oil. • Change the rear-axle oil. • Change the hydraulic filters.
Before each use or daily	<ul style="list-style-type: none"> • Check the tire pressure. • Check the safety-interlock switches. • Check the engine-oil level. • Check the air-cleaner indicator. • Drain water or other contaminants from the fuel filter/water separator. • Check the coolant level. • Check the hydraulic-fluid level. • Remove all debris and chaff from the engine compartment, radiator and oil cooler. • Check the interlock-switch operation
Every 25 hours	<ul style="list-style-type: none"> • Check the electrolyte level. (If the machine is in storage, check it every 30 days.)
Every 50 hours	<ul style="list-style-type: none"> • Lubricate all of the bearings and bushings. • Inspect the air cleaner. • Check the blade-drive-belt tension.
Every 100 hours	<ul style="list-style-type: none"> • Inspect the cooling-system hoses and clamps. • Check the alternator-belt tension. • Check the compressor-belt tension.
Every 200 hours	<ul style="list-style-type: none"> • Torque the wheel-lug nuts.
Every 250 hours	<ul style="list-style-type: none"> • Change the engine oil and filter. • Clean the cab air filters; replace them if they are torn or excessively dirty. • Clean the air-conditioning assembly (more frequently in extremely dusty or dirty conditions).
Every 400 hours	<ul style="list-style-type: none"> • Check the planetary-gear-drive oil (check if you notice external leakage). • Check for end-play in the planetary drives. • Check the rear-axle lubricant. • Check the rear-axle-gear-box lubricant. • Service the air cleaner (earlier if the air cleaner indicator shows red, and more frequently in extremely dirty or dusty conditions). • Inspect the fuel lines and connections. • Replace the fuel-filter canister. • Replace the engine fuel filter.
Every 500 hours	<ul style="list-style-type: none"> • Grease the bearings in the rear axle.

Maintenance Service Interval	Maintenance Procedure
Every 800 hours	<ul style="list-style-type: none"> • Drain and clean the fuel tank. (also if the fuel system is contaminated). • Change the front planetary-gear oil or yearly, whichever comes first. • Change the rear-axle oil. • Check the rear wheel toe-in. • Inspect the blade-drive belt. • Change the hydraulic fluid. • Change the hydraulic filters. • Inspect the side mower-deck damper. • Inspect the mower deck caster-wheel assemblies.
Every 1,000 hours	<ul style="list-style-type: none"> • Check and adjust the valve clearance.
Every 3,000 hours	<ul style="list-style-type: none"> • Remove and clean the diesel particulate filter or as needed.
Every 6,000 hours	<ul style="list-style-type: none"> • Replace the diesel oxidation catalyst.
Every 2 years	<ul style="list-style-type: none"> • Flush the cooling system and replace the fluid. • Replace moving hoses.

▲ CAUTION

If you leave the key in the switch, someone could accidentally start the engine and seriously injure you or other bystanders.

Remove the key from the switch before you do any maintenance.

Daily Maintenance Checklist

Duplicate this page for routine use.

Maintenance Check Item	For the week of:						
	Monday	Tuesday	Wednesday	Thursday	Friday	Saturday	Sunday
Check the safety-interlock operation.							
Check the brake operation.							
Check the engine-oil level.							
Check the cooling-system-fluid level.							
Drain the water/fuel separator.							
Check the air filter, dust cup, and burp valve.							
Check for unusual engine noises. ²							
Check the radiator and screen for debris							
Check for unusual operating noises.							
Check the hydraulic-system-oil level.							
Check the hydraulic hoses for damage.							
Check for fluid leaks.							
Check the fuel level.							
Check the tire pressure.							
Check the instrument operation.							
Check the height-of-cut adjustment.							
Lubricate all the grease fittings. ²							
Touch up any damaged paint.							

¹Check the glow plug and injector nozzles if starting is hard, there is excess smoke, or rough running is noted.

²Immediately **after every** washing, regardless of the interval listed.

Important: Refer to your engine owner's manual for additional maintenance procedures.

Notation for Areas of Concern

Inspection performed by:		
Item	Date	Information

Service-Interval Chart

GROUNDMASTER 4010, MODEL 30635 & 30636 QUICK REFERENCE AID

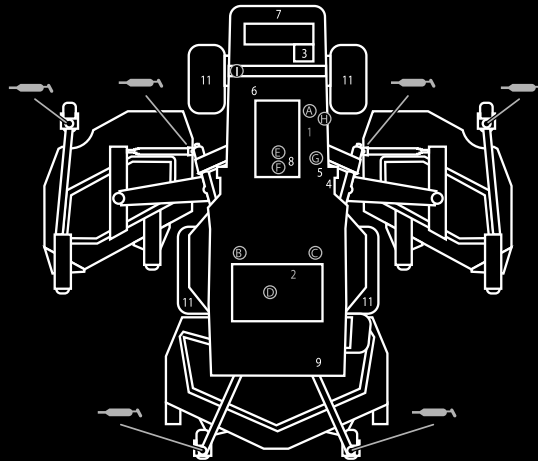

CHECK/SERVICE (DAILY)

- | | |
|--------------------------|-------------------------------------|
| 1. ENGINE OIL LEVEL | 8. AIR CLEANER |
| 2. HYDRAULIC FLUID LEVEL | 9. BRAKE FUNCTION |
| 3. ENGINE COOLANT LEVEL | 10. INTERLOCK SYSTEM |
| 4. FUEL - DIESEL ONLY | 11. TIRE PRESSURE - 25 PSI/1.70 BAR |
| 5. FUEL/WATER SEPARATOR | 12. GREASE POINTS (6) |
| 6. FAN BELT TENSION | SEE OPERATOR'S MANUAL FOR |
| 7. RADIATOR SCREEN | 50 HR INTERVAL GREASE POINTS. |



SPECIFICATIONS/CHANGE INTERVALS

SEE OPERATOR'S MANUAL FOR INITIAL CHANGES.	FLUID TYPE		CAPACITY	CHANGE INTERVAL		FILTER PART NO.	
				FLUID	FILTER		
ENGINE OIL	30635	15W-40, CI-4	6 QUARTS	250 HOURS	250 HOURS	125-7025 (A)	
	30636	15W-40, CJ-4					
HYDRAULIC FLUID	ISO VG 46/68		7.75 GALLONS	800 HOURS	800 HOURS	75-1310 (B) 94-2621 (C)	
HYDRAULIC BREATHER					800 HRS/YRLY	115-9793 (D)	
PRIMARY AIR FILTER					SEE SERVICE INDICATOR	108-3814 (E)	
SAFETY AIR FILTER					SEE OPERATOR'S MANUAL	108-3816 (F)	
FUEL SYSTEM	> 32 F	NO. 2 DIESEL	21 GALLONS	800 HOURS DRAIN/FLUSH	400 HOURS/YEARLY	30635	110-9049 (G)
		NO. 1 DIESEL				30636	125-2915 (H) 125-8752 (H)
	< 32 F						
REAR AXLE	85W-140		80 OUNCES	800 HOURS			
PLANETARY DRIVE	85W-140		22 OUNCES	800 HOURS			
ENGINE COOLANT	50% WATER 50% ETHYL GLYCOL		14.5 QUARTS	DRAIN & FLUSH EVERY 2 YRS.			

130-6046

Figure 38

decal130-6046

GROUNDMASTER 4000, MODEL 30605 & 30609

QUICK REFERENCE AID



CHECK/SERVICE (DAILY)

- 1. ENGINE OIL LEVEL
 - 2. HYDRAULIC FLUID LEVEL
 - 3. ENGINE COOLANT LEVEL
 - 4. FUEL - DIESEL ONLY
 - 5. FUEL/WATER SEPARATOR
 - 6. FAN BELT TENSION
 - 7. RADIATOR SCREEN
 - 8. AIR CLEANER
 - 9. BRAKE FUNCTION
 - 10. INTERLOCK SYSTEM
 - 11. TIRE PRESSURE - 25 PSI/1.70 BAR
 - 12. GREASE POINTS (6)
- SEE OPERATOR'S MANUAL FOR 50 HR INTERVAL GREASE POINTS.

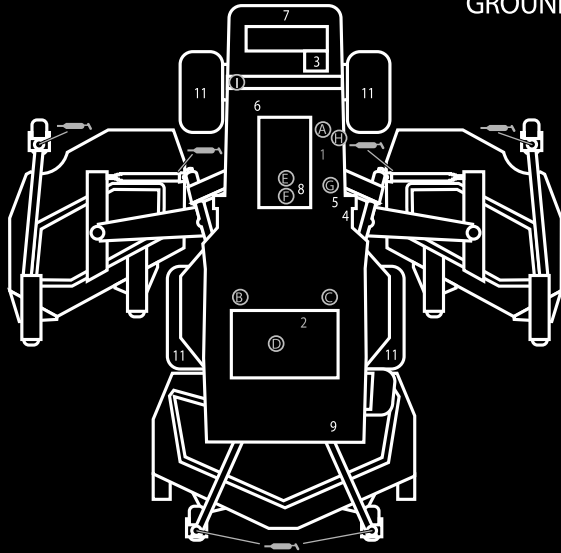

SPECIFICATIONS/CHANGE INTERVALS

SEE OPERATOR'S MANUAL FOR INITIAL CHANGES	FLUID TYPE	CAPACITY	CHANGE INTERVAL		FILTER PART NO.
			FLUID	FILTER	
ENGINE OIL	30605 15W-40, CH-4	6 QUARTS	250 HOURS	250 HOURS	125-7025 (A)
	30609 15W-40, CH-4				
HYDRAULIC FLUID	ISO VG 46/68	7.75 GALLONS	800 HOURS	800 HOURS	75-1310 (B)
HYDRAULIC BREATHER				800 HRS/YRLY	94-2621 (C)
PRIMARY AIR FILTER				SEE SERVICE MANUAL	115-9793 (D)
SAFETY AIR FILTER				SEE OPERATOR'S MANUAL	108-3814 (E)
FUEL SYSTEM	> 32 F NO. 2 DIESEL	21 GALLONS	800 HOURS DRAIN/FLUSH	400 HOURS/YEARLY	108-3816 (F)
	< 32 F NO. 1 DIESEL				30605 110-9049 (G)
					30609 125-2915 (H)
REAR AXLE	85W-140	80 OUNCES	800 HOURS		110-4812 BREATHER (I)
PLANETARY DRIVE	85W-140	22 OUNCES	800 HOURS		
ENGINE COOLANT	50% WATER 50% ETHYLENE GLYCOL	9 QUARTS	DRAIN & FLUSH EVERY 2 YRS.		

130-6043

Figure 39

decal130-6043

Pre-Maintenance Procedures

Pre-Maintenance Safety

- Before adjusting, cleaning, repairing, or leaving the machine, do the following:
 - Park the machine on a level surface.
 - Move the throttle switch to the low-idle position.
 - Disengage the cutting units.
 - Lower the cutting units.
 - Ensure that the traction is in neutral.
 - Engage the parking brake.
 - Shut off the engine and remove the key.
 - Wait for all moving parts to stop.
 - Allow machine components to cool before performing maintenance.
- If the cutting units are in the transport position, use the positive mechanical lock (if available) before you leave the machine unattended.
- If possible, do not perform maintenance while the engine is running. Keep away from moving parts.
- Use jack stands to support the machine or components when required.
- Carefully release pressure from components with stored energy.

Preparing the Machine for Maintenance

1. Ensure that the PTO is disengaged.
2. Park the machine on a level surface.
3. Engage the parking brake.
4. Lower the mower deck(s) if necessary.
5. Shut off the engine and wait for all moving parts to stop.
6. Turn the key to the STOP position and remove it.
7. Allow machine components to cool before performing maintenance.

Removing the Hood

1. Unlatch and raise the hood.
2. Remove the hairpin cotter securing the hood pivot to the mounting brackets (Figure 40).

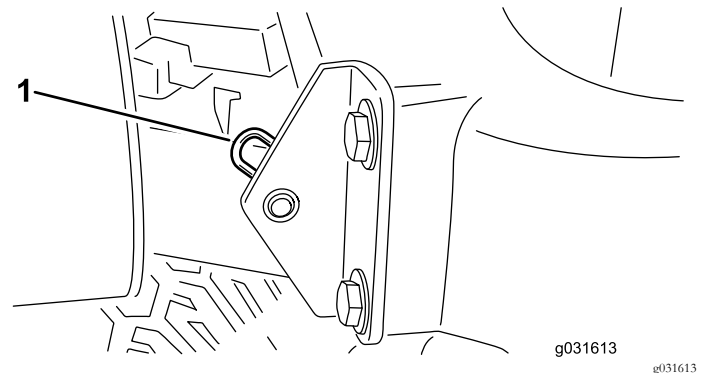

Figure 40

1. Hairpin cotter

3. Slide the hood to the right side, lift the other side, and pull it out of the brackets.

Note: Reverse this procedure to install the hood.

Lubrication

Greasing the Bearings and Bushings

Service Interval: Every 50 hours—Lubricate all of the bearings and bushings.

Every 500 hours/Yearly (whichever comes first)

The machine has grease fittings that you must lubricate regularly with No. 2 lithium grease. Also, lubricate the machine immediately after every washing.

The grease-fitting locations and quantities are:

Traction Unit

- 2 front and rear-axle-pivot bushings (Figure 41)
- 2 steering-cylinder-ball joints (Figure 42)
- 2 tie-rod-ball joints (Figure 42)
- 2 king-pin bushings (Figure 42).
The top fitting on the king pin should only be lubricated annually (2 pumps).

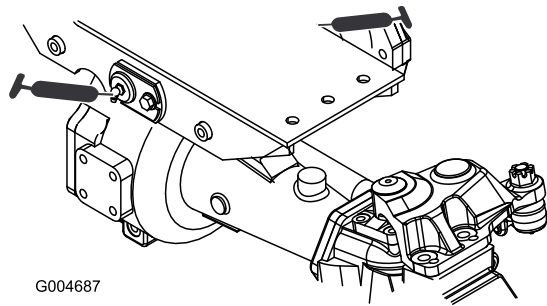

Figure 41

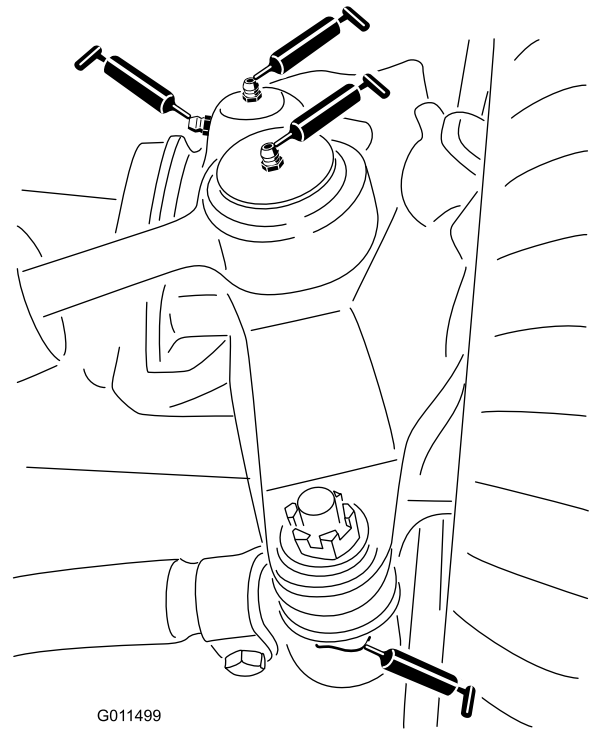

Figure 42

Front Mower Deck

- 2 caster-fork-shaft bushings (Figure 43)
- 3 spindle-shaft bearings—located under the pulley (Figure 44)
- 2 idler-arm-pivot bushings (Figure 44)

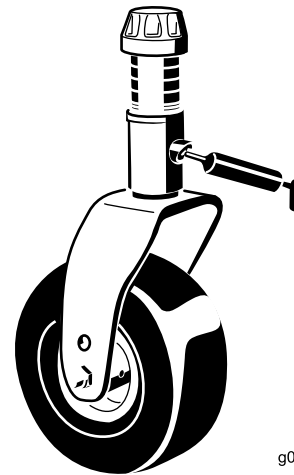

Figure 43

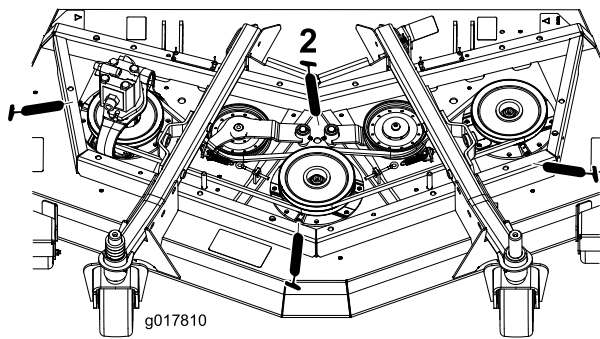

Figure 44

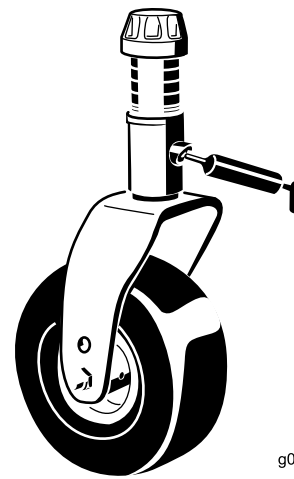

Figure 47

Front Lift Assemblies

- 2 (each side) lift-arm-cylinder bushings (Figure 45)
- 2 lift-arm-ball joints (Figure 46)

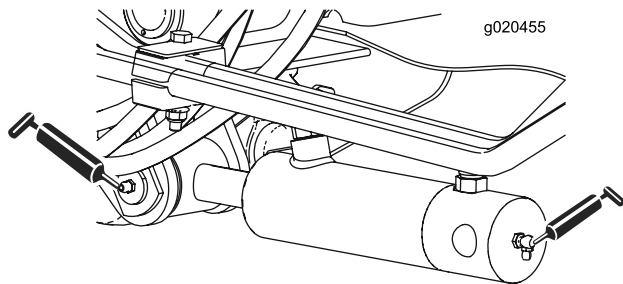

Figure 45

Side Lift Assemblies

- 6 main lift-arm bushings (Figure 48 and Figure 49)
- 2 bell-crank-pivot bushings (Figure 50)
- 4 rear arm bushings (Figure 50)
- 4 lift-cylinder bushings (Figure 51)

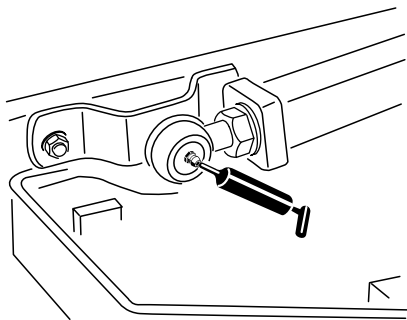

Figure 46

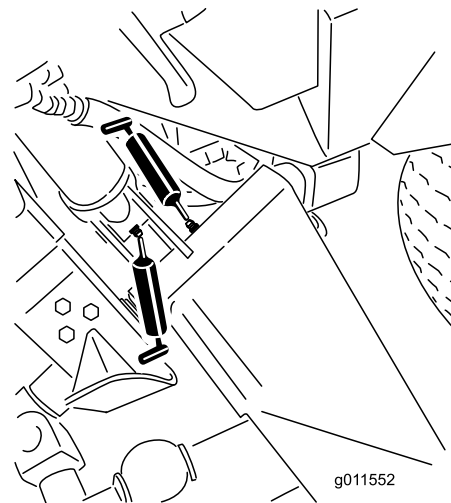

Figure 48

Side Mower Decks

- 1 caster-fork-shaft bushing (Figure 47)
- 2 (each side) spindle-shaft bearings—located under the pulley
- 1 idler-arm-pivot bushings—located on the idler arm

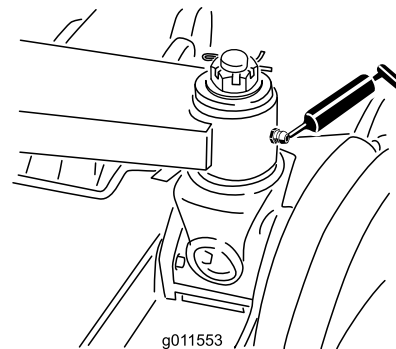

Figure 49

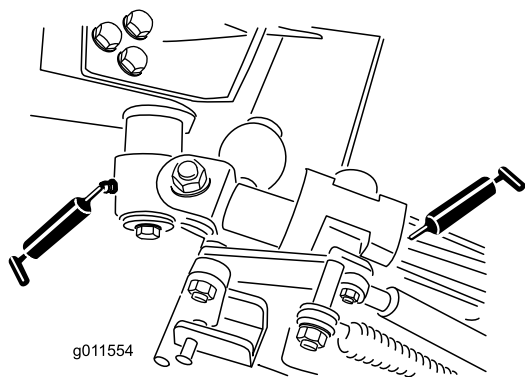

Figure 50

g011554

Engine Maintenance

Engine Safety

- Shut off the engine before checking the oil or adding oil to the crankcase.
- Do not change the governor speed or overspeed the engine.

Servicing the Engine Oil

Checking the Engine-Oil Level

Service Interval: Before each use or daily

The engine is shipped with oil in the crankcase; however, the oil level must be checked before and after the engine is first started.

The crankcase capacity is approximately 5.7 L (6 US qt) with the filter.

Use high-quality engine oil that meets the following specifications:

- **API Classification Level Required:** CJ-4 or higher.
- **Preferred oil:** SAE 15W-40 (above -18°C [0°F])

Note: Toro Premium Engine oil is available from your distributor in 15W-40 viscosity. See the *Parts Catalog* for part numbers.

Note: The best time to check the engine oil is when the engine is cool before it has been started for the day. If it has already been run, allow the oil to drain back down to the sump for at least 10 minutes before checking. If the oil level is at or below the Add mark on the dipstick, add oil to bring the oil level to the Full mark. **Do not overfill.** If the oil level is between the Full and Add marks, no oil addition is required.

1. Park the machine on a level surface.
2. Check the engine-oil level ([Figure 52](#)).

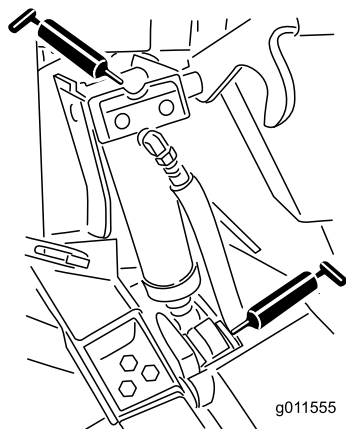

Figure 51

g011555

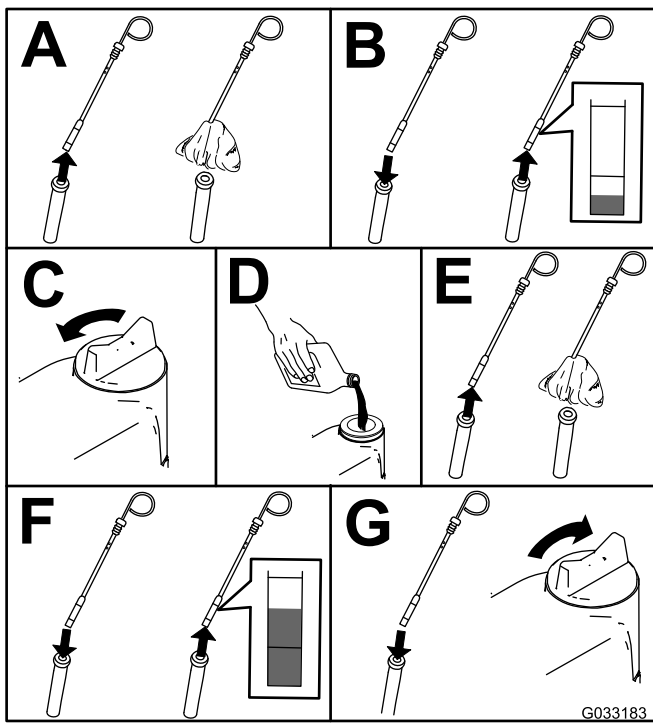

Figure 52

G033183
g033183

Note: When using different oil, drain all old oil from the crankcase before adding new oil.

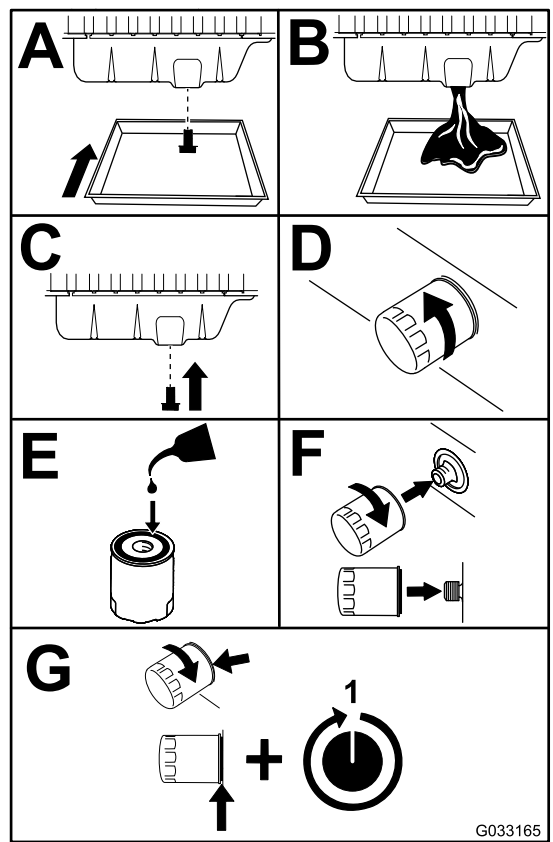

Figure 53

G033165

g033165

Changing the Engine Oil and Filter

Service Interval: After the first 50 hours

Every 250 hours

1. Start the engine and let it run 5 minutes to allow the oil to warm up.
2. With the machine parked on a level surface, shut off the engine, remove the key, and wait for all moving parts to stop before leaving the operating position.
3. Replace the engine oil and filter (Figure 53).

4. Add oil to the crankcase.

Servicing the Air Cleaner

Service Interval: Before each use or daily

Every 50 hours

Every 400 hours

Check the air-cleaner body for damage which could cause an air leak. Replace it if it is damaged. Check the whole intake system for leaks, damage, or loose hose clamps.

Service the air-cleaner filter only when the service indicator (Figure 54) requires it. Changing the air filter before it is necessary only increases the chance of dirt entering the engine when you remove the filter.

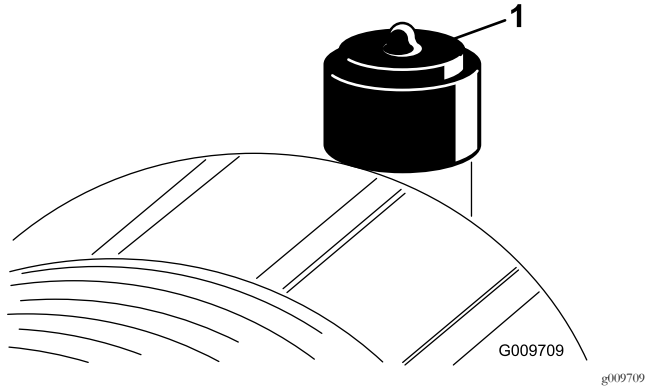

Figure 54

1. Air-cleaner indicator

Important: Ensure that the cover is seated correctly and seals with the air-cleaner body.

1. Replace the air cleaner (Figure 55).

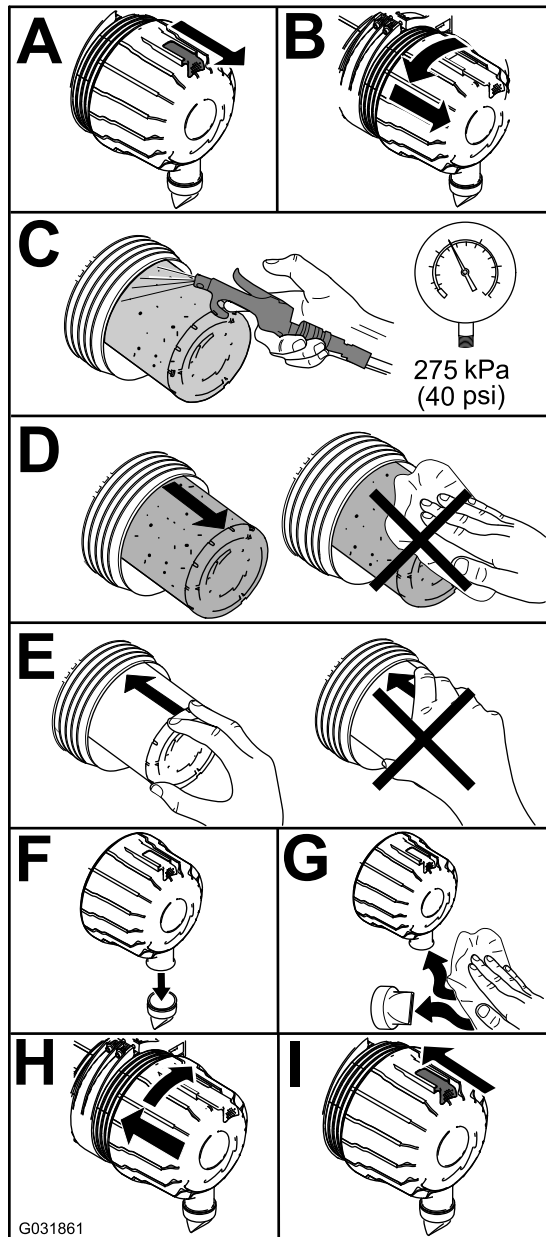

Figure 55

Note: Do not clean a used element because cleaning it can damage the filter media.

Important: Never attempt to clean the safety filter (Figure 56). Replace the safety filter after every 3 primary filter services.

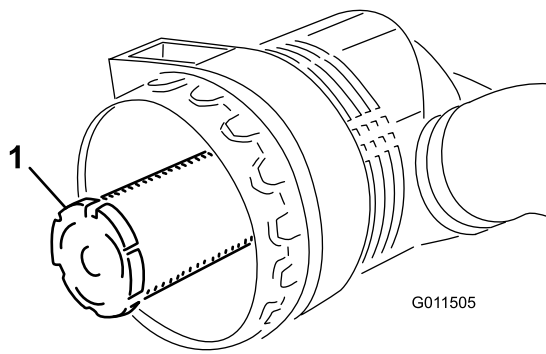

Figure 56

1. Air-cleaner safety filter

2. Reset the indicator ([Figure 54](#)) if it shows red.

Servicing the Diesel Particulate Filter (DPF)

Service Interval: Every 3,000 hours or as needed.

For information on servicing the diesel particulate filter (DPF), refer to the service manual or contact your Toro distributor.

Servicing the Diesel Oxidation Catalyst (DOC)

Service Interval: Every 6,000 hours

For information on servicing the diesel oxidation catalyst (DOC), refer to the *service manual* or contact your Toro distributor.

Fuel System Maintenance

Servicing the Fuel System

Draining the Fuel Tank

Service Interval: Every 800 hours—Drain and clean the fuel tank. (also if the fuel system is contaminated).

Drain and clean the tank also if the fuel system becomes contaminated or if you are storing the machine for an extended period of time. Use clean fuel to flush out the tank.

Inspecting the Fuel Lines and Connections

Service Interval: Every 400 hours

Inspect the fuel lines and connections for deterioration, damage, or loose connections.

Servicing the Water Separator

Service Interval: Before each use or daily—Drain water or other contaminants from the fuel filter/water separator.

Every 400 hours—Replace the fuel-filter canister.

Service the water separator as shown in [Figure 57](#).

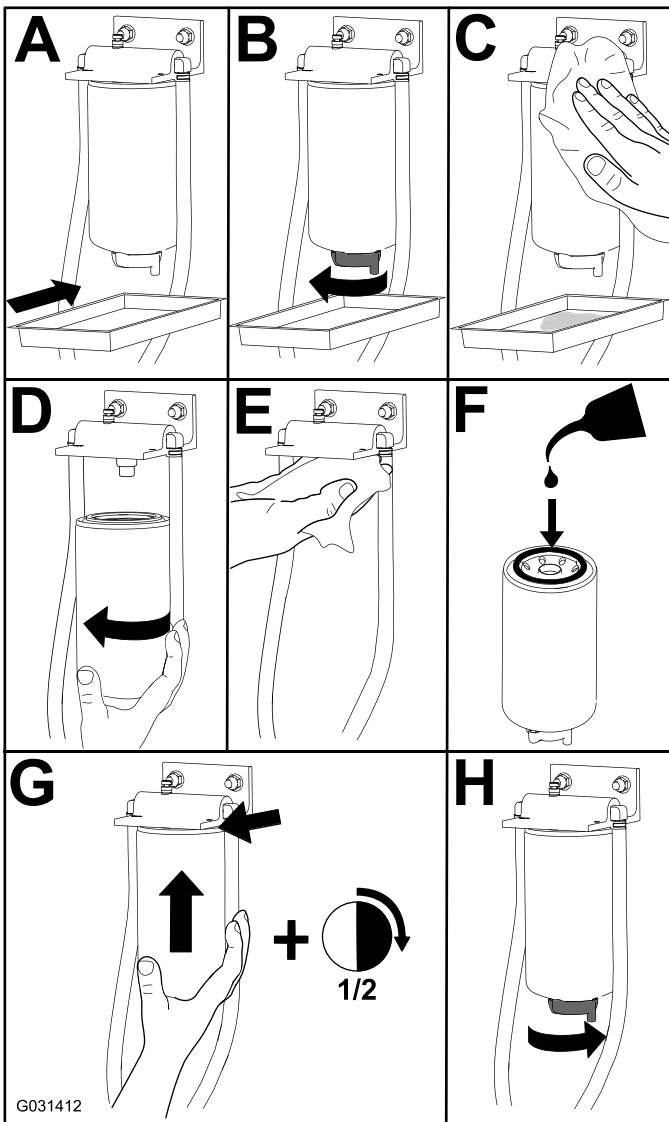

Figure 57

Servicing the Fuel Filter

Service Interval: Every 400 hours

1. Clean the area around the fuel-filter head (Figure 58).

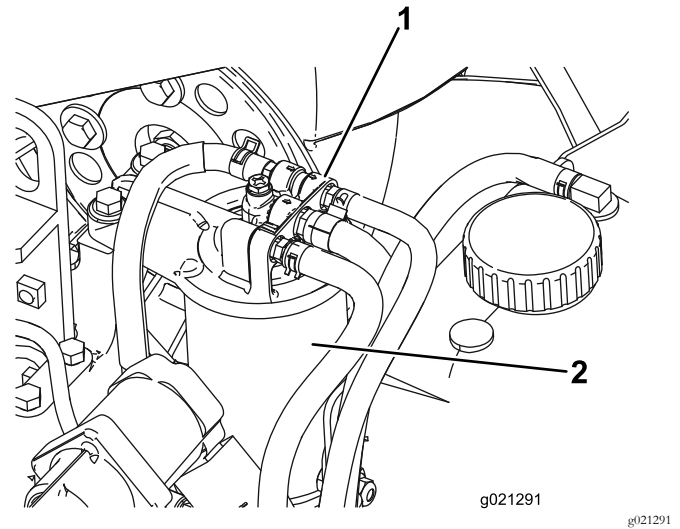

Figure 58

1. Fuel-filter head
 2. Fuel filter
-
2. Remove the filter and clean the filter head mounting surface (Figure 58).
 3. Lubricate the filter gasket with clean lubricating engine oil; refer to the engine owner's manual for additional information.
 4. Install the dry filter canister by hand until the gasket contacts the filter head, then rotate it an additional 1/2 turn.
 5. Start the engine and check for fuel leaks around the filter head.

Electrical System Maintenance

Electrical System Safety

- Disconnect the battery before repairing the machine. Disconnect the negative terminal first and the positive last. Connect the positive terminal first and the negative last.
- Charge the battery in an open, well-ventilated area, away from sparks and flames. Unplug the charger before connecting or disconnecting the battery. Wear protective clothing and use insulated tools.

WARNING

CALIFORNIA Proposition 65 Warning

Battery posts, terminals, and related accessories contain lead and lead compounds, chemicals known to the State of California to cause cancer and reproductive harm. Wash hands after handling.

Servicing the Battery

Service Interval: Every 25 hours—Check the electrolyte level. (If the machine is in storage, check it every 30 days.)

Important: Before welding on the machine, disconnect the negative cable from the battery to prevent damage to the electrical system.

Note: Check the battery condition weekly or after every 50 hours of operation. Keep the terminals and the entire battery case clean because a dirty battery will discharge slowly. To clean the battery, wash the entire case with a solution of baking soda and water. Rinse with clear water. Coat the battery posts and cable connectors with Grafo 112X (skin-over) grease (Toro Part No. 505-47) or petroleum jelly to prevent corrosion.

1. Open the battery cover on the side of the shroud (Figure 59).

Note: Press down on the flat surface above the battery cover to ease the removal of the cover (Figure 59).

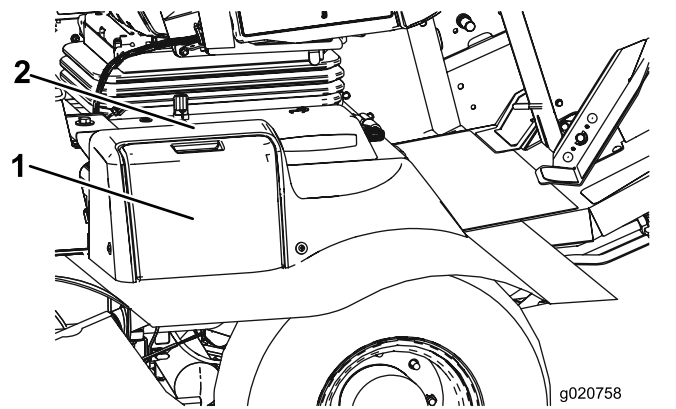

Figure 59

1. Battery cover
2. Press down here.

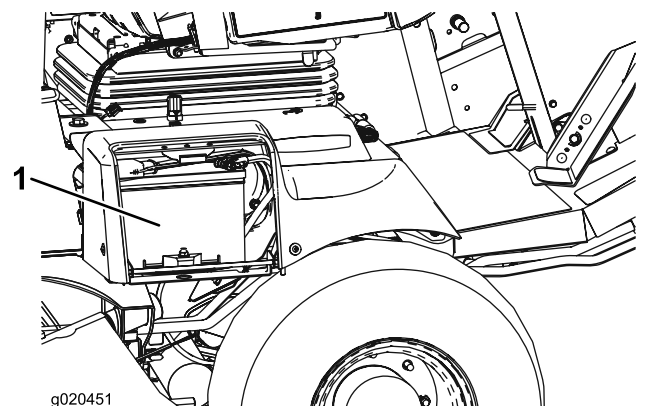

Figure 60

1. Battery

⚠ WARNING

Charging the battery produces gasses that can explode.

Never smoke near the battery and keep sparks and flames away from battery.

2. Remove the rubber boot from the positive terminal and inspect the battery.

⚠ WARNING

Battery terminals or metal tools could short against metal components, causing sparks. Sparks can cause the battery gasses to explode, resulting in personal injury.

- When removing or installing the battery, do not allow the battery terminals to touch any metal parts of the machine.
- Do not allow metal tools to short between the battery terminals and metal parts of the machine.

⚠ WARNING

Incorrect battery cable routing could damage the machine and cables, causing sparks. Sparks can cause the battery gasses to explode, resulting in personal injury.

- Always *disconnect* the negative (black) battery cable before disconnecting the positive (red) cable.
 - Always *connect* the positive (red) battery cable before connecting the negative (black) cable.
3. Coat both battery connections with Grafo 112X (skin-over) grease, Toro Part No. 505-47, petroleum jelly, or light grease to prevent corrosion.
 4. Slide the rubber boot over the positive terminal.
 5. Close the battery cover.

Locating the Fuses

The traction-unit fuses are located under the power-center cover (Figure 61, Figure 62, and Figure 63).

Remove the 2 screws securing the power-center cover to the frame and remove the cover (Figure 61).

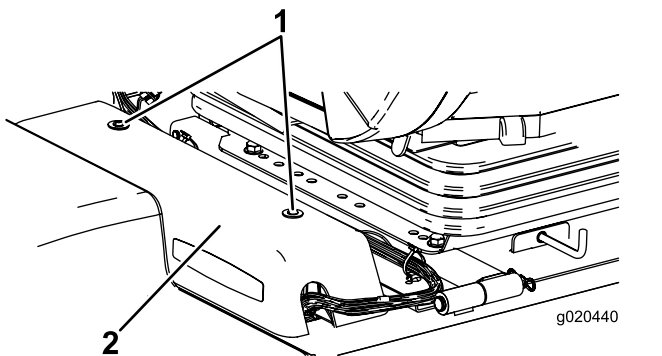

Figure 61

1. Power-center cover
2. Screws

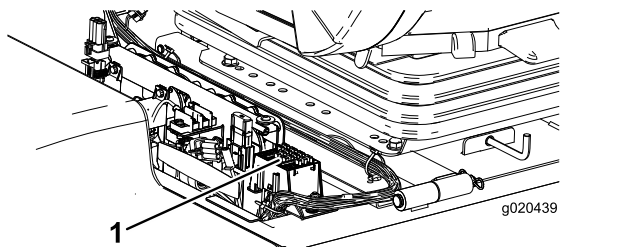

Figure 62

1. Fuses

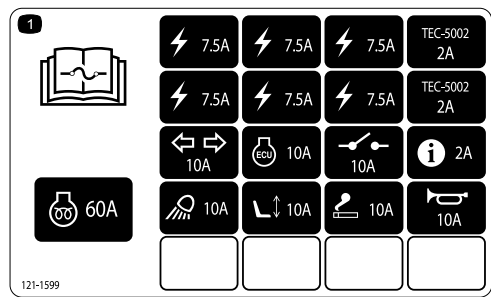

Figure 63

decal121-1599

The cab fuses are located in the fuse box in the cab headliner (Figure 64 and Figure 65).

Note: Cab model only

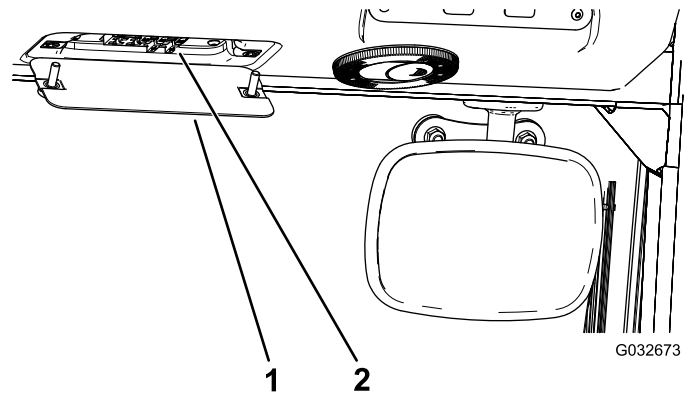

Figure 64

1. Cab fuse box
2. Fuses

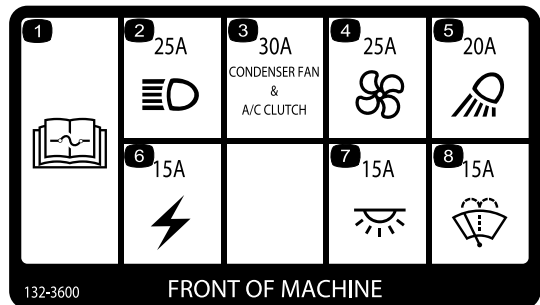

Figure 65

decal132-3600

Drive System Maintenance

Adjusting the Traction-Pedal Angle

1. Loosen the 2 nuts and bolts securing the left side of the traction pedal to the bracket (Figure 66).

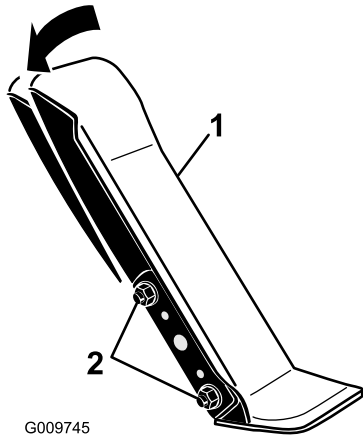

G009745

g009745

Figure 66

1. Traction pedal
2. Mounting nuts and bolts

2. Pivot the pedal to the desired operating angle and tighten the nuts (Figure 66).

Changing the Planetary-Gear-Drive Oil

Service Interval: After the first 200 hours

Every 800 hours or yearly, whichever comes first.

Use a high-quality, SAE 85W-140 gear lube.

1. With the machine on a level surface, position a wheel so a check plug is at the lowest (6 o'clock) position (Figure 67).

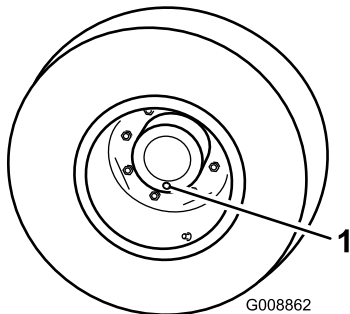

G008862

g008862

Figure 67

1. Check/drain plug

2. Place a drain pan under the planetary hub, remove the plug, and allow the oil to drain.
3. Place a drain pan under the brake housing, remove the drain plug, and allow the oil to drain (Figure 68).

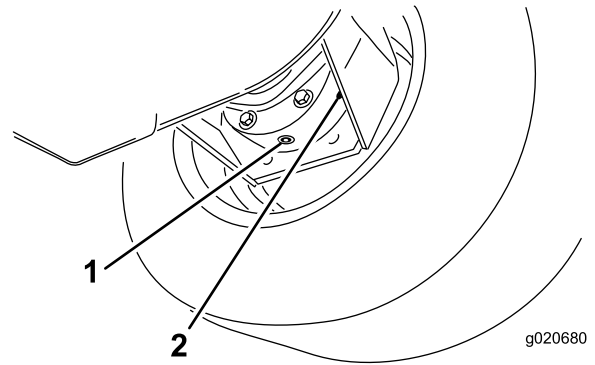

g020680

g020680

Figure 68

1. Drain plug
2. Brake housing

4. When all of the oil has drained from both locations, install the plug in the brake housing.
5. Rotate the wheel until the open plug hole in the planetary is at the 12 o'clock position.
6. Through the open hole, slowly fill the planetary with 0.65 L (22 fl oz) of high quality SAE 85W-140 wt gear lube.

Important: If the planetary fills before the 0.65 L (22 fl oz) of oil is added, wait one hour or install the plug and move the machine approximately ten feet to distribute the oil through the brake system. Then, remove the plug and add the remaining oil.

7. Install the plug.
8. Repeat the procedure on the opposite planetary/brake assembly.

Changing the Rear-Axle Oil

Service Interval: After the first 200 hours

Every 800 hours

1. Position the machine on a level surface.
2. Clean the area around the 3 drain plugs; 1 on each end and 1 in the center (Figure 69).
3. Remove the check plugs to make draining the oil easier.
4. Remove the drain plugs and allow the oil to drain into the pans.

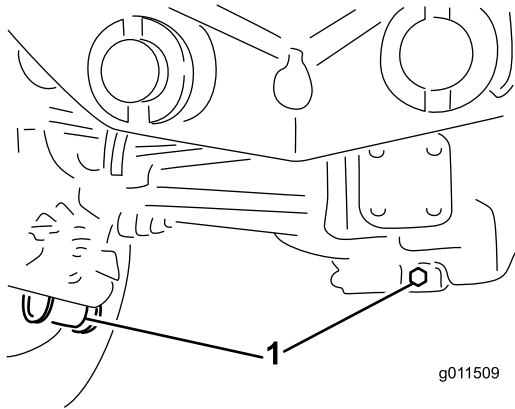

Figure 69

1. Drain-plug location

-
5. Clean the area around the drain plug at the bottom of the gear box (Figure 70).
 6. Remove the drain plug from the gearbox and allow the oil to drain into a pan.

Note: Remove the fill plug to make draining the oil easier.

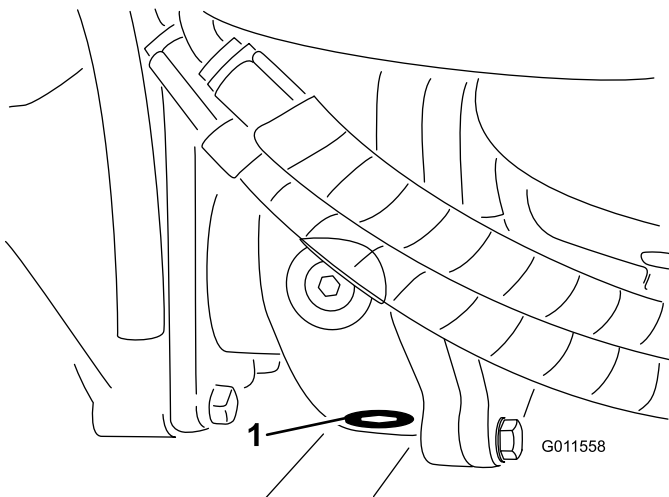

Figure 70

1. Drain plug

7. Add enough oil to bring the level up to the bottom of the check plug holes; refer to [Checking the Rear-Axle Lubricant \(page 26\)](#).
8. Install the plugs.

Checking the Rear Wheel Toe-In

Service Interval: Every 800 hours

1. Measure the center-to-center distance (at axle height) at the front and rear of the steering tires.

Note: The front measurement must be 6 mm (1/4 inch) less than the rear measurement.

2. To adjust, loosen the clamps at both ends of the tie rods.
3. Rotate the tie-rod end to move the front of the tire inward or outward.
4. Tighten the tie-rod clamps when the adjustment is correct.

Cooling System Maintenance

Cooling System Safety

- Swallowing engine coolant can cause poisoning; keep out of reach from children and pets.
- Discharge of hot, pressurized coolant or touching a hot radiator and surrounding parts can cause severe burns.
 - Always allow the engine to cool at least 15 minutes before removing the radiator cap.
 - Use a rag when opening the radiator cap, and open the cap slowly to allow steam to escape.

Checking the Cooling System

Service Interval: Before each use or daily

Check the coolant level at the beginning of each day. The capacity of the system is 8.5 L (9 US qt).

1. Carefully remove the radiator cap and expansion-tank cap (Figure 71).
2. Check the coolant level in the radiator.

Note: The radiator should be filled to the top of the filler neck and the expansion tank filled to the Full mark.

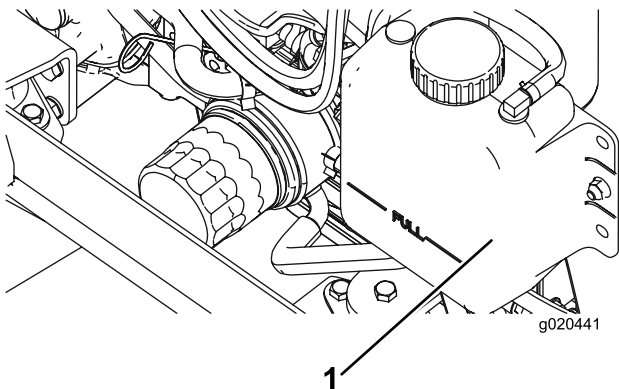

Figure 71

1. Expansion tank

3. If the coolant is low, add a 50/50 mixture of water and ethylene glycol anti-freeze.

Important: Do not use water only or alcohol/methanol based coolants, as this may cause damage.

4. Install the radiator cap and expansion-tank cap.

Servicing the Engine-Cooling System

Service Interval: Every 100 hours

Every 2 years

Remove debris from the oil radiator/oil cooler daily. Clean them more frequently in dirty conditions.

This machine is equipped with a hydraulically-driven fan drive system that automatically (or manually) reverses to reduce the radiator/oil cooler and screen debris buildup. While this feature can help reduce the time required to clean radiator/oil cooler, it does not eliminate the need for routine cleaning. Periodic cleaning and inspection of the radiator/oil cooler is still required.

1. Shut off the engine and raise the hood.
2. Clean the engine area thoroughly of all debris.
3. Clean both sides of the radiator/oil cooler area thoroughly with compressed air (Figure 72).

Note: Start from the fan side and blow the debris out toward the back. Then, clean from the back side and blow toward the front. Repeat this procedure several times until all chaff and debris is removed.

Important: Cleaning the radiator/oil cooler with water can promote premature corrosion and damage to components.

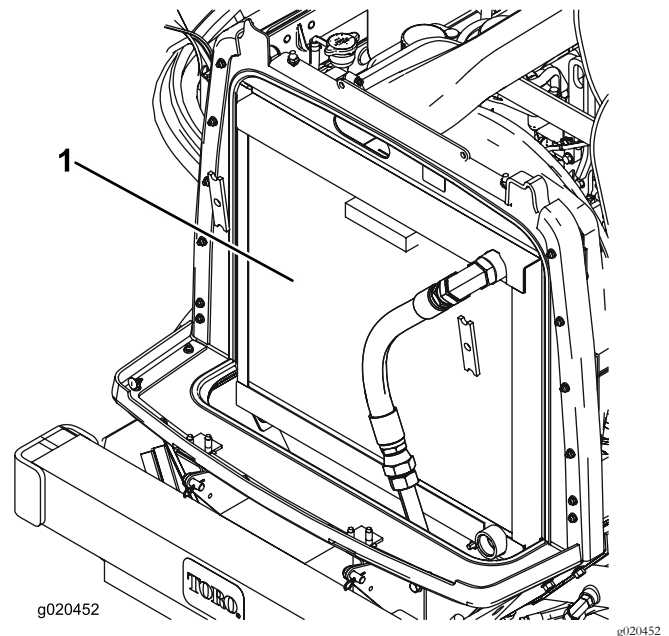

Figure 72

1. Radiator/oil cooler

4. Close the hood.

Brake Maintenance

Adjusting the Service Brakes

Adjust the service brakes when there is more than 25 mm (1 inch) of free travel of the brake pedal, or when the brakes do not work effectively. Free travel is the distance the brake pedal moves before you feel braking resistance.

1. Release the locking latch from the brake pedals so that both pedals work independently of each other.
2. To reduce free travel of the brake pedals, tighten the brakes as follows:
 - A. Loosen the front nut on the threaded end of the brake cable (Figure 73).

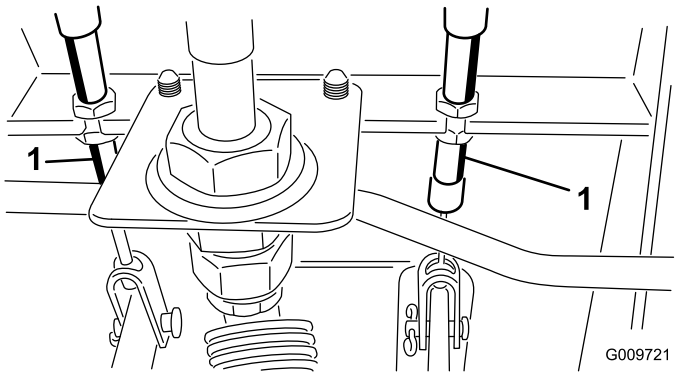

Figure 73

1. Brake cable

- B. Tighten the rear nut to move the cable rearward until the brake pedals have 13 to 25 mm (1/2 to 1 inch) of free travel.
- C. Tighten the front nuts after the brakes are adjusted correctly.

Belt Maintenance

Servicing the Alternator Belt

Service Interval: After the first 10 hours

Every 100 hours

Proper tension of the belt allows 10 mm (3/8 inch) of deflection when a force of 44 N·m (10 ft-lb) is applied on the belt midway between the pulleys.

If the deflection is not 10 mm (3/8 inch), loosen the alternator-mounting bolts (Figure 74).

Note: Increase or decrease the alternator-belt tension and tighten the bolts. Check the deflection of the belt again to ensure that the tension is correct.

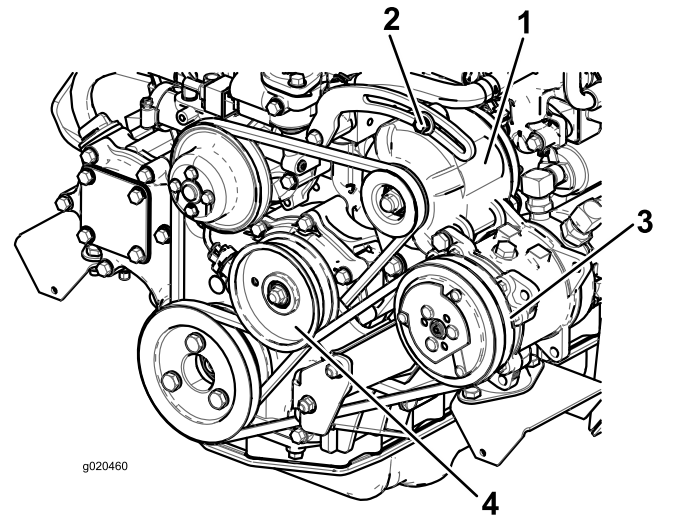

Figure 74

- | | |
|------------------|-----------------|
| 1. Alternator | 3. Compressor |
| 2. Mounting bolt | 4. Idler pulley |

Servicing the Compressor Belt

Service Interval: After the first 10 hours

Every 100 hours

1. Proper tension of the belt allows 10 mm (3/8 inch) of deflection when a force of 44 N·m (10 ft-lb) is applied on the belt midway between the pulleys.
2. If the deflection is not 10 mm (3/8 inch), loosen the idler pulley mounting bolt (Figure 74).

Note: Increase or decrease the compressor-belt tension and tighten the bolt. Check the deflection of the belt again to ensure that the tension is correct.

Tensioning the Blade-Drive Belts

Service Interval: After the first 10 hours

Every 50 hours

When properly tensioned, the inside measurement of the extension spring (hook to hook) should be approximately 8.3 to 9.5 cm (3-1/4 to 3-3/4 inches). Once the correct spring tension is attained, adjust the stop bolt (carriage bolt) until there is approximately 2 to 5 mm (0.065 to 0.185 inch) clearance between the head of the bolt and the idler arm (Figure 75).

Note: Ensure that the belt is positioned on the spring side of the belt guide (Figure 75).

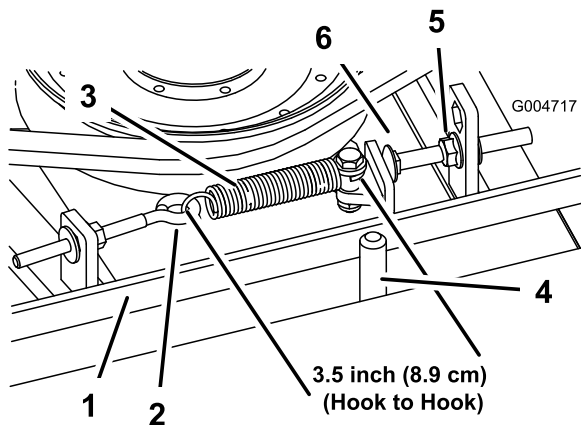

Figure 75

- | | |
|---------------------|---------------|
| 1. Belt | 4. Belt guide |
| 2. Eye bolt | 5. Flange nut |
| 3. Extension spring | 6. Stop bolt |

Replacing the Blade-Drive Belt

Service Interval: Every 800 hours

The blade-drive belt, tensioned by the spring-loaded idler pulley, is very durable. However, after many hours of use, the belt will show signs of wear. Signs of a worn belt are: squealing when the belt is rotating, blades slipping when cutting grass, frayed edges, burn marks, and cracks. Replace the belt if any of these conditions are evident.

1. Lower the mower deck to the shop floor, remove the belt covers from the top of the mower deck, and set the covers aside.
2. Loosen the eye bolt allowing the removal of the extension spring (Figure 75).
3. Loosen the flange nut securing the stop bolt to the mounting tab and move the idler pulley away from the belt to release the belt tension (Figure 75).

Note: Loosen the nut enough to allow the idler arm to pass the stop bolt.

Note: If the stop bolt is ever removed from the mounting tab, make sure that it is installed again in the hole that aligns the stop-bolt head with the idler arm.

4. Remove the bolts securing the hydraulic motor to the mower deck (Figure 76).

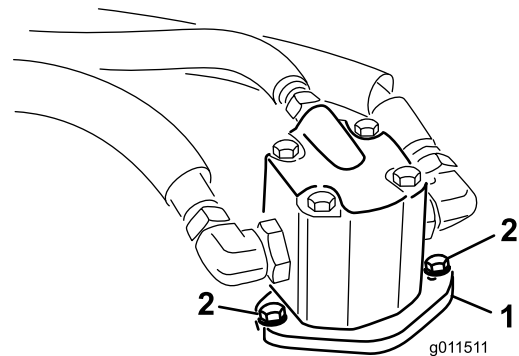

Figure 76

- | | |
|--------------------|-------------------|
| 1. Hydraulic motor | 2. Mounting bolts |
|--------------------|-------------------|

5. Lift the motor off the mower deck and lay it on top of the mower deck.
6. Remove the old belt from around the spindle pulleys and idler pulley.
7. Route the new belt around the spindle pulleys and idler-pulley assembly.
8. Position the hydraulic motor on the mower deck after routing the belt around the pulleys. Mount the motor to the mower deck with the bolts previously removed.

Note: Ensure that the belt is positioned on the spring side of the belt guide (Figure 75).

9. Connect the extension spring (Figure 75) to the eye bolt and tension the belt as follows:
 - When properly tensioned, the inside measurement of the extension spring (hook to hook) should be approximately 8.27 to 9.53 cm (3.25 to 3.75 inches).
 - When you attain the correct spring tension, adjust the stop bolt (carriage bolt) until there is approximately 0.17 to 0.47 cm (0.065 to 0.185 inches) clearance between the head of the bolt and the idler arm.

Hydraulic System Maintenance

Hydraulic System Safety

- Ensure that all hydraulic-fluid hoses and lines are in good condition and all hydraulic connections and fittings are tight before applying pressure to the hydraulic system.
- Keep your body and hands away from pinhole leaks or nozzles that eject high-pressure hydraulic fluid.
- Use cardboard or paper to find hydraulic leaks.
- Safely relieve all pressure in the hydraulic system before performing any work on the hydraulic system.
- Seek immediate medical attention if fluid is injected into skin. Injected fluid must be surgically removed within a few hours by a doctor.

Servicing the Hydraulic System

Checking the Hydraulic Fluid

Service Interval: Before each use or daily

The reservoir is filled at the factory with approximately 29 L (7.75 US gallons) of high-quality hydraulic fluid. Check the level of the hydraulic fluid before the engine is first started and daily thereafter. The recommended replacement fluid is as follows:

Toro Premium All Season Hydraulic Fluid (Available in 19 L (5 US gallons) pails or 208 L (55 US gallons) drums. See the *Parts Catalog* or your Toro Distributor for part numbers).

Alternative fluids: If the Toro fluid is not available, other **conventional, petroleum-based** fluids may be used, provided they meet all of the following material properties and industry specifications. Check with your oil supplier to see whether the oil meets these specifications.

Note: Toro does not assume responsibility for damage caused by improper substitutions, so use only products from reputable manufacturers who will stand behind their recommendation.

High Viscosity Index/Low Pour Point Anti-wear Hydraulic Fluid, ISO VG 46

Material Properties:

Viscosity, ASTM D445 St @ 40° C 44 to 48

St @ 100° C 7.9 to 8.5

Viscosity Index ASTM D2270 140 to 160

Pour Point, ASTM D97 -34° F to -49° F

Industry Specifications: Vickers I-286-S (Quality Level), Vickers M-2950-S (Quality Level), Denison HF-0

The proper hydraulic fluids must be specified for mobile machinery (as opposed to industrial plant usage), multi-weight type, with ZnDTP or ZDDP anti-wear additive package (not an ashless-type fluid).

Toro Synthetic Biodegradable Hydraulic Fluid (Available in 19 L (5 US gallon) pails or 208 L (55 US gallon) drums. See the *Parts Catalog* or your Toro Distributor for part numbers)

This high quality synthetic, biodegradable fluid has been tested and found compatible for this Toro model. Other brands of synthetic fluid may have seal compatibility problems and Toro cannot assume responsibility for unauthorized substitutions.

Important: This synthetic fluid is not compatible with the Toro Biodegradable Fluid previously sold. See your Toro Distributor for more information.

Alternative biodegradable fluids:

Mobil EAL EnviroSyn H 46 (US)

Mobil EAL Hydraulic Oil 46 (International)

Important: Many hydraulic fluids are almost colorless, making it difficult to spot leaks. A red dye additive for the hydraulic system oil is available in 20 ml (2/3 fl oz) bottles. 1 bottle is sufficient for 15 to 22 L (4 to 6 US gallons) of hydraulic oil. Order Part No. 44-2500 from your Toro Distributor.

1. Position the machine on a level surface, lower the mower decks, shut off the engine, and remove the key.
2. Check the hydraulic-fluid level ([Figure 77](#)).

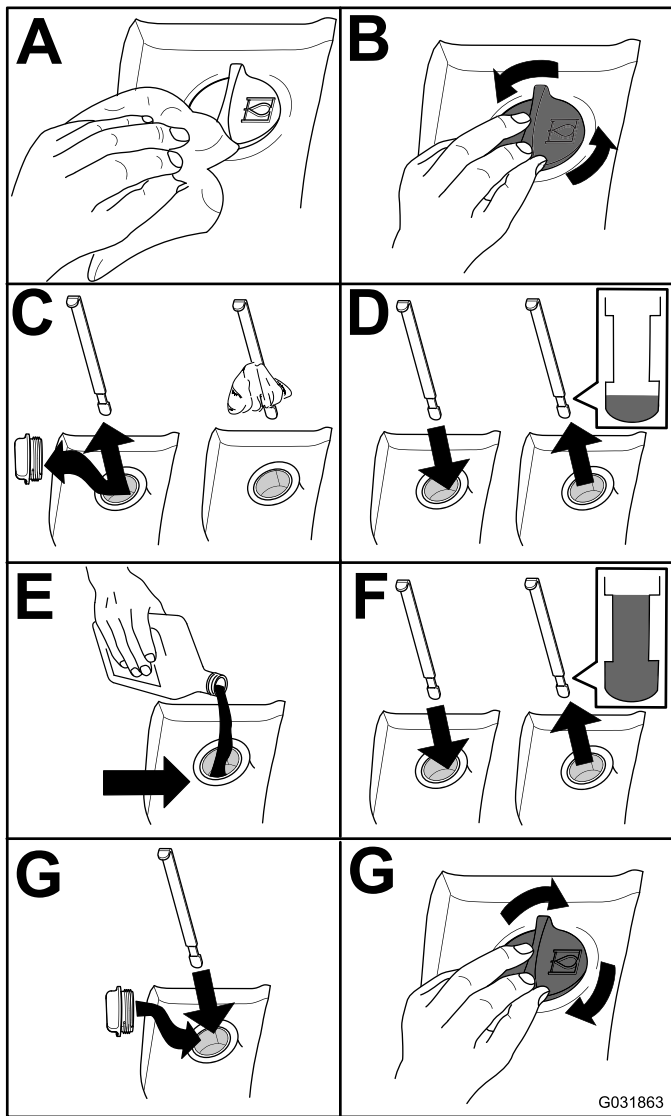

Figure 77

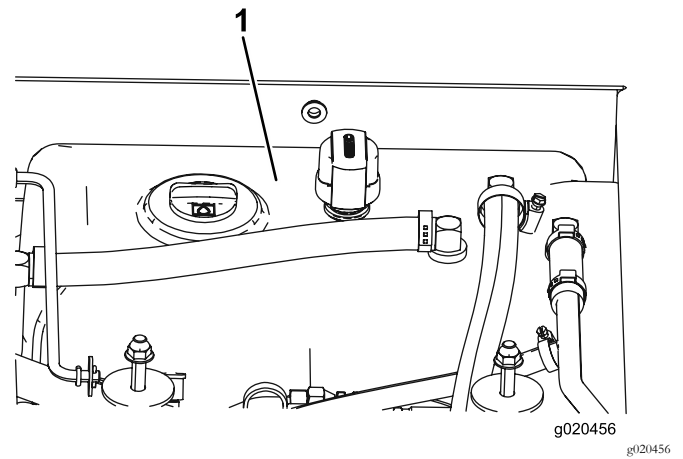

Figure 78

1. Hydraulic reservoir

5. Install the reservoir cap, start the engine, and use all the hydraulic controls to distribute hydraulic fluid throughout the system.
- Note:** Also check for leaks; then shut off the engine.
6. Check the fluid level and add enough to raise level the level to the Full mark on the dipstick.

Note: Do not overfill.

Replacing the Hydraulic Filters

Service Interval: After the first 200 hours

Every 800 hours

Use Toro replacement filters Part No. 94-2621 for the rear (mower deck) of the machine and Part No. 75-1310 for the front (charge) of the machine.

Important: Use of any other filter may void the warranty on some components.

1. Position the machine on a level surface, lower the mower decks, engage the parking brakes, shut off the engine, and remove the key.
2. Replace the hydraulic filters (Figure 79).

Changing the Hydraulic Fluid

Service Interval: Every 800 hours

If the fluid becomes contaminated, contact your local Toro distributor because the system must be flushed. Contaminated fluid looks milky or black when compared to clean oil.

1. Position the machine on a level surface, lower the mower decks, shut off the engine, and remove the key.
2. Remove the drain plug from the bottom, front of the reservoir and let the hydraulic fluid flow into a large drain pan.
3. Install and tighten the plug when the hydraulic fluid stops draining.
4. Fill the reservoir (Figure 78) with hydraulic fluid; refer to [Checking the Hydraulic Fluid](#) (page 59).

Important: Use only the hydraulic fluids specified. Other fluids damage the system.

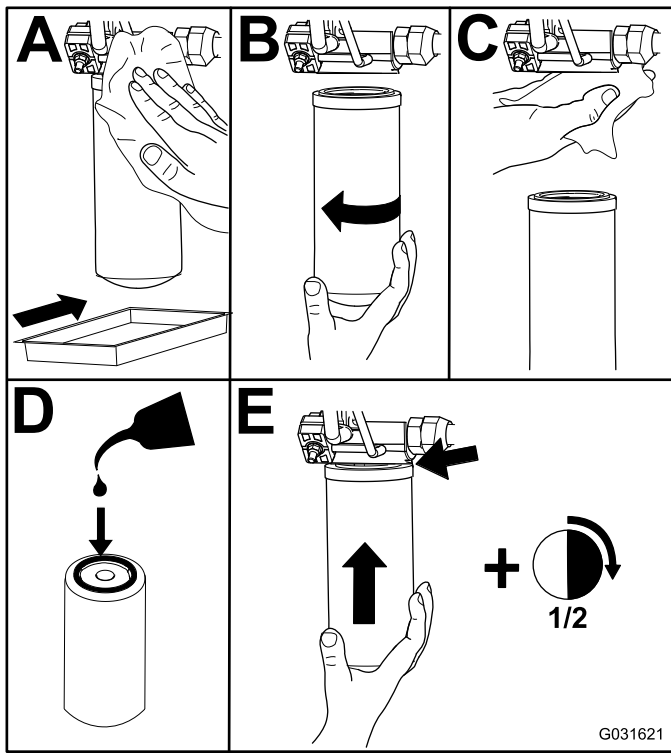

Figure 79

G031621

g031621

3. Start the engine and let it run for about 2 minutes to purge air from the system and shut off the engine and check for leaks.

Checking the Hydraulic Lines and Hoses

Service Interval: Every 2 years

Inspect the hydraulic lines and hoses daily for leaks, kinked lines, loose mounting supports, wear, loose fittings, weather deterioration, and chemical deterioration. Make all necessary repairs before operating.

Adjusting the Counterbalance Pressure

The counterbalance test port is used to test the pressure in the counterbalance circuit (Figure 80). The recommended counterbalance pressure is 2241 kPa (325 psi). To adjust the counterbalance pressure, loosen the locknut, rotate the adjusting screw (Figure 80) clockwise to increase the pressure or counterclockwise to decrease the pressure, and tighten the locknut. The engine must be running and the deck lowered and in the float position to check the pressure.

Note: The caster wheels of all 3 mower decks should remain on the ground when adjusting the counterbalance and with counterbalance applied.

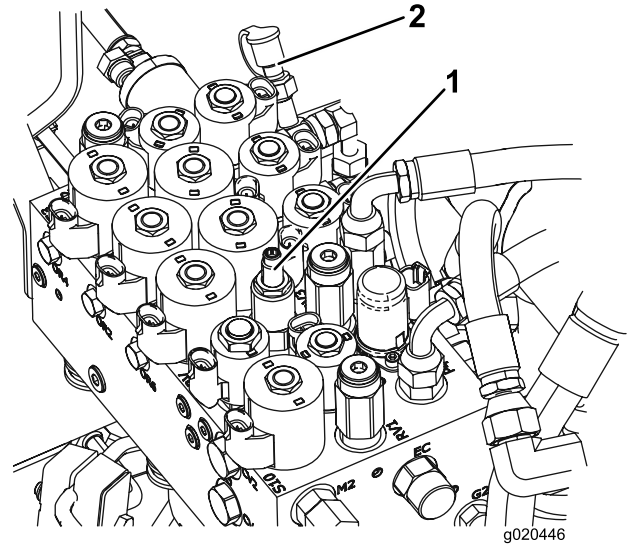

Figure 80

g020446

g020446

1. Counterbalance-adjusting screw
2. Counterbalance-test port screw

Mower Maintenance

Pivoting (Tilting) the Front Mower Deck to the Upright Position

Note: Although not needed for normal maintenance procedures, you can pivot (tilt) the front mower deck to an upright position. To tilt the mower deck, do the following.

1. Raise the front mower deck slightly off the floor, engage the parking brake, shut off the engine, and remove the key.
2. Remove the hairpin cotter and clevis pin securing the deck-transport latch to the latch plate and pivot the latch toward the rear of the deck.
3. Remove the hairpin cotter and clevis pin securing the height-of-cut chains to the rear of the mower deck.
4. Start the engine, slowly raise the front mower deck, shut off the engine, and remove the key.
5. Grasp the front of the mower deck and lift it to an upright position.
6. Hold the mower deck upright, fit the cable end over the pin on the mower deck lift arm, and secure it with the hairpin cotter (Figure 81).

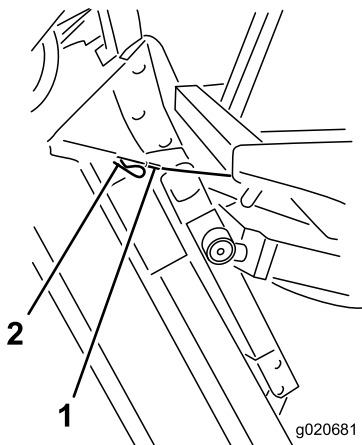

Figure 81

1. Cable

2. Pin

Pivoting the Front Mower Deck Down

1. With the help of another person, hold the mower deck upright, remove the hairpin cotter securing the cable end, and remove the cable from the pin.
2. Pivot (tilt) the mower deck downward.
3. Store the cable under the operator's platform.

4. Sit on the seat, start the engine, and lower the mower deck until it is slightly off the floor.
5. Secure the height-of-cut chains to the rear of the mower deck.
6. Pivot the transport latch upward into position and secure it with the clevis pin and cotter pin.

Adjusting the Mower-Deck Pitch

Measuring the Mower-Deck Pitch

Mower-deck pitch is the difference in height of cut from the front of the blade plane to the back of the blade plane. Toro recommends a blade pitch of 8 to 11 mm (5/16 to 7/16 inch). That is the back of the blade plane is 8 to 11 mm (5/16 to 7/16 inch) higher than the front.

1. Position the machine on a level surface on the shop floor.
2. Set the mower deck to the desired height of cut.
3. Rotate a blade to point straight forward.
4. Using a short ruler, measure from the floor to the front tip of the blade.
5. Rotate the blade tip to the rear and measure from the floor to the tip of the blade.
6. Subtract the front dimension from the rear dimension to calculate the blade pitch.

Adjusting the Front Mower-Deck Pitch

1. Loosen the jam nuts at the top or bottom of the height-of-cut chain U-bolt (Figure 82).
2. Adjust the other set of nuts to raise or lower the rear of the mower deck and attain the correct mower-deck pitch.
3. Tighten the jam nuts.

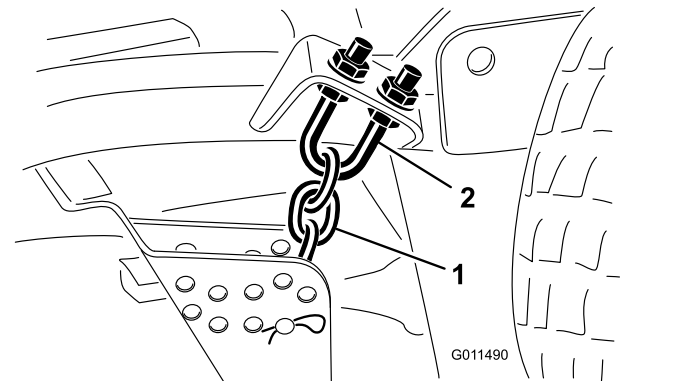

Figure 82

1. Height-of-cut chain

2. U-bolt

Adjusting the Side Mower-Deck Pitch

Service Interval: Every 800 hours

1. Remove the tensioning cap from the spindle shaft and slide the spindle out of the caster arm (Figure 83).

Note: Position the shims, as required, to raise or lower the caster wheel until the mower deck has the correct pitch.

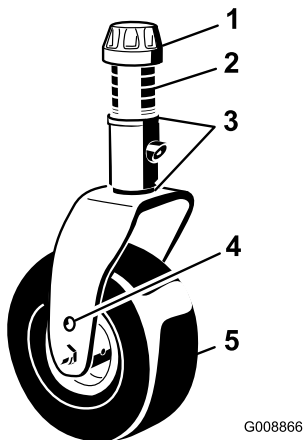

Figure 83

- | | |
|-------------------|------------------------|
| 1. Tensioning cap | 4. Axle-mounting holes |
| 2. Spacers | 5. Caster wheel |
| 3. Shims | |

2. Install the tensioning cap.

Servicing the Caster-Arm Bushings

The caster arms have bushings pressed into the top and bottom of the tube and after many hours of operation, the bushings develop wear. To check the bushings, move the caster fork back and forth and from side to side. If the caster spindle is loose inside the bushings, the bushings are worn and must be replaced.

1. Raise the mower deck so the wheels are off the floor and block the mower deck so it cannot fall.
2. Remove the tensioning cap, spacer(s), and thrust washer from the top of the caster spindle.
3. Pull the caster spindle out of the mounting tube.

Note: Keep the thrust washer and spacer(s) on the bottom of the spindle.

4. Insert a pin punch into the top or bottom of the mounting tube and drive the bushing out of the tube (Figure 84).

Note: Also drive the other bushing out of the tube. Clean the inside of the tubes to remove dirt.

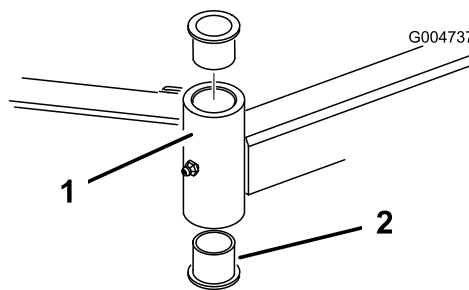

Figure 84

- | | |
|--------------------|-------------|
| 1. Caster-arm tube | 2. Bushings |
|--------------------|-------------|

5. Apply grease to the inside and outside of the new bushings.
6. Using a hammer and flat plate, drive the bushings into the mounting tube.
7. Inspect the caster spindle for wear and replace it if it is damaged.
8. Push the caster spindle through the bushings and mounting tube.
9. Slide the thrust washer and spacer(s) onto the spindle and install the tensioning cap on the caster spindle to retain all parts in place.

Servicing the Caster Wheels and Bearings

Service Interval: Every 800 hours

1. Remove the locknut from the bolt holding the caster-wheel assembly between the caster fork (Figure 85) or the caster-pivot arm (Figure 86).

Note: Grasp the caster wheel and slide the bolt out of the fork or pivot arm.

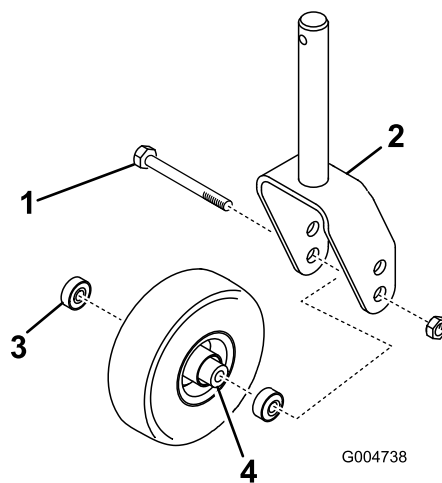

Figure 85

- | | |
|----------------|-------------------|
| 1. Caster bolt | 3. Bearing |
| 2. Caster fork | 4. Bearing spacer |

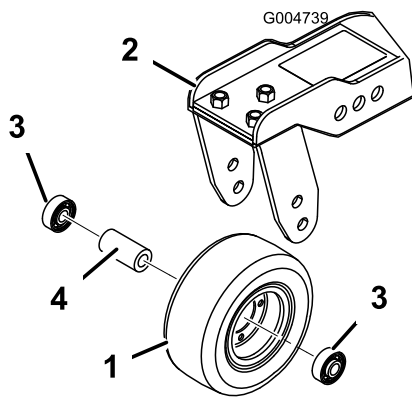

Figure 86

g004739

- | | |
|---------------------|-------------------|
| 1. Caster wheel | 3. Bearing |
| 2. Caster-pivot arm | 4. Bearing spacer |

2. Remove the bearing from the wheel hub and allow the bearing spacer to fall out (Figure 85 and Figure 86).
 3. Remove the bearing from the opposite side of the wheel hub.
 4. Check the bearings, spacer, and inside of the wheel hub for wear and replace any damaged parts.
 5. To assemble the caster wheel, push the bearing into the wheel hub.
- Note:** When installing the bearings, press on the outer race of the bearing.
6. Slide the bearing spacer into the wheel hub and push the other bearing into the open end of the wheel hub to captivate the bearing spacer inside the wheel hub.
 7. Install the caster-wheel assembly between the caster fork and secure it in place with the bolt and locknut.

Blade Maintenance

Blade Safety

A worn or damaged blade can break, and a piece of the blade could be thrown toward you or bystanders, resulting in serious personal injury or death.

- Inspect the blade periodically for wear or damage.
- Use care when checking the blades. Wrap the blades or wear gloves, and use caution when servicing the blades. Only replace or sharpen the blades; never straighten or weld them.
- On multi-bladed machines, take care as rotating 1 blade can cause other blades to rotate.

Checking for a Bent Blade

After striking a foreign object, inspect the machine for damage and make repairs before starting and operating the equipment. Torque all of the spindle-pulley nuts to 176 to 203 N·m (130 to 150 ft-lb).

1. Position the machine on a level surface, raise the mower deck, engage the parking brake, put the traction pedal in NEUTRAL, put the PTO lever in the OFF position, shut off the engine, and remove the key.

Note: Block the mower deck to prevent it from accidentally falling.

2. Rotate the blade until the ends face forward and backward and measure from the inside of the mower deck to the cutting edge at the front of the blade (Figure 87).

Note: Remember this dimension.

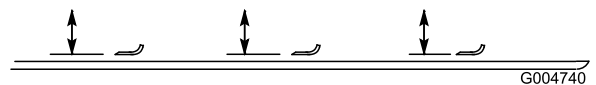

g004740

Figure 87

3. Rotate the opposite end of the blade forward and measure between the mower deck and cutting edge of the blade at the same position as in step 2.

Note: The difference between the dimensions obtained in steps 2 and 3 must not exceed 3 mm (1/8 inch). If the dimension exceeds 3 mm (1/8 inch), the blade is bent and must be replaced; refer to [Removing and Installing the Mower Blade\(s\)](#) (page 65).

Removing and Installing the Mower Blade(s)

Replace the blade if it hits a solid object, is out of balance, or if it is bent. Always use genuine Toro replacement blades to ensure safety and optimum performance.

1. Raise the mower deck to the highest position, engage the parking brake, shut off the engine, and remove the key.

Note: Block the mower deck to prevent it from accidentally falling.

2. Grasp the end of the blade using a rag or thickly-padded glove.
3. Remove the blade bolt, anti-scalp cup, and blade from the spindle shaft (Figure 88).

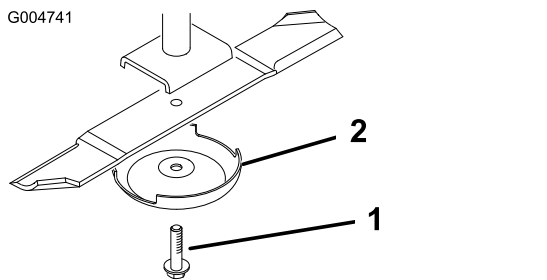

Figure 88

1. Blade bolt
2. Anti-scalp cup

4. Install the blade, anti-scalp cup, and blade bolt and tighten the blade bolt to 115 to 149 N·m (85 to 110 ft-lb).

Important: The curved part of the blade must be pointing toward the inside of the mower deck to ensure proper cutting.

Note: After striking a foreign object, torque all of the spindle-pulley nuts to 115 to 149 N·m (85 to 110 ft-lb).

Inspecting and Sharpening the Mower Blade(s)

Two areas must be considered when checking and servicing the mower blade—the sail and the cutting edge. Both cutting edges and the sail, which is the turned-up portion opposite of the cutting edge, contribute to a good quality of cut. The sail is important because it lifts the grass up straight, thereby producing an even cut. However, the sail gradually wears down during operation. As the sail wears down, the quality of cut degrades, although the cutting edges are sharp. The cutting edge of the blade must be sharp so that the grass is cut rather than torn. A dull cutting edge is evident when the tips of the grass appear brown and shredded. Sharpen the cutting edges to correct this condition.

1. Park the machine on a level surface, raise the mower deck, engage the parking brake, put the traction pedal in NEUTRAL, put the PTO lever in the OFF position, shut off the engine, and remove the key.
2. Examine the cutting ends of the blade carefully, especially where the flat and curved parts of the blade meet (Figure 89).

Note: Because sand and abrasive material can wear away the metal that connects the flat and curved parts of the blade, check the blade before using the mower. If wear is noticed (Figure 89), replace the blade.

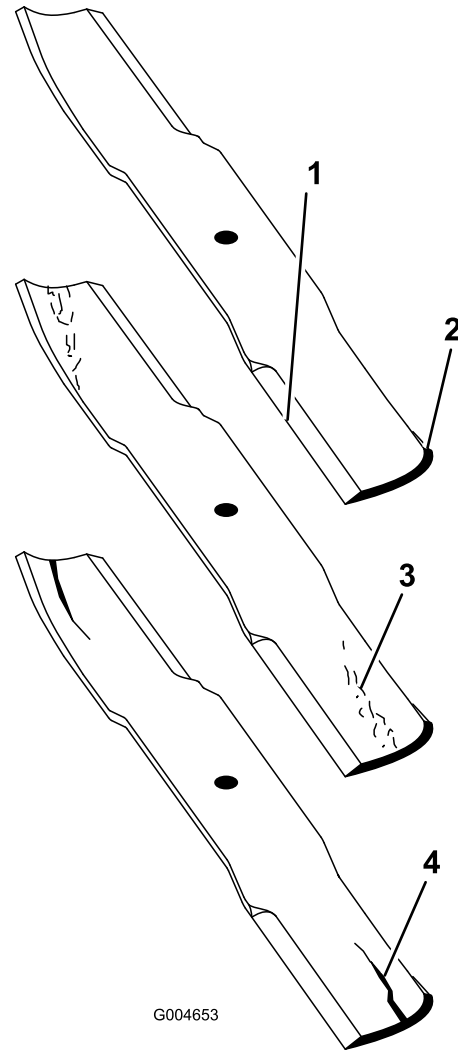

Figure 89

1. Cutting edge
2. Curved area
3. Wear/slot forming
4. Crack

3. Examine the cutting edges of all the blades and sharpen the cutting edges if they are dull or nicked (Figure 90).

Note: Sharpen only the top of the cutting edge and maintain the original cutting angle to ensure sharpness (Figure 90). The blade remains balanced if the same amount of metal is removed from both cutting edges.

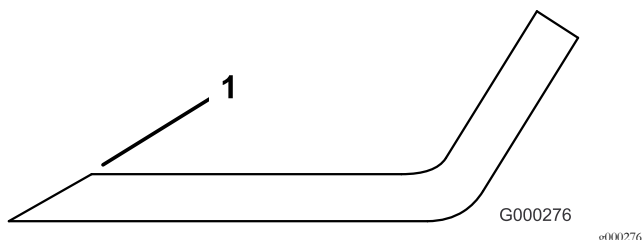

Figure 90

1. Sharpen at the original angle.

Note: Remove the blades and sharpen them on a grinder. After sharpening the cutting edges, install the blade with the anti-scalp cup and blade bolt; refer to [Removing and Installing the Mower Blade\(s\)](#) (page 65).

Correcting a Mower-Deck Mismatch

If there is mismatch between the blades, on a single mower deck, the grass will appear streaked when it is cut. This problem can be corrected by ensuring that the blades are straight and all of the blades are cutting on the same plane.

1. Park the machine on a level surface of the shop floor.
2. Raise the height of cut to the highest position; refer to [Adjusting the Height of Cut](#) (page 27).
3. Lower the mower deck onto the flat surface and remove the covers from the top of the mower deck.
4. Loosen the flange nut securing the idler pulley to release the belt tension.
5. Rotate the blades until the ends face forward and rearward and measure from the floor to the front tip of the cutting edge.

Note: Remember this dimension. Then rotate the same blade so that the opposite end is forward, and measure again. The difference between the dimensions must not exceed 3 mm (1/8 inch). If the dimension exceeds 3 mm (1/8 inch), replace the blade because it is bent. Measure all the blades.

6. Compare the measurements of the outer blades with the center blade.

Note: The center blade must not be more than 10 mm (3/8 inch) lower than the outer blades. If the center blade is more than 10 mm (3/8 inch) lower than the outer blades, proceed to step 7 and add shims between the spindle housing and the bottom of the mower deck.

7. Remove the bolts, flat washers, lock washers, and nuts from the outer spindle in the area where the shims must be added.

Note: To raise or lower the blade, add a shim (Part No. 3256-24) between the spindle housing and the bottom of the mower deck. Continue to check the

alignment of the blades and add shims until the tips of the blades are within the required dimension.

Important: Do not use more than 3 shims at any 1 hole location. Use decreasing numbers of shims in adjacent holes if more than 1 shim is added to any 1 hole location.

8. Adjust the idler pulley and install the belt covers.

Cab Maintenance

Cleaning the Cab Air Filters

Service Interval: Every 250 hours

1. Remove the screws and grates from both the in-cab and rear cab air filters (Figure 91 and Figure 92).

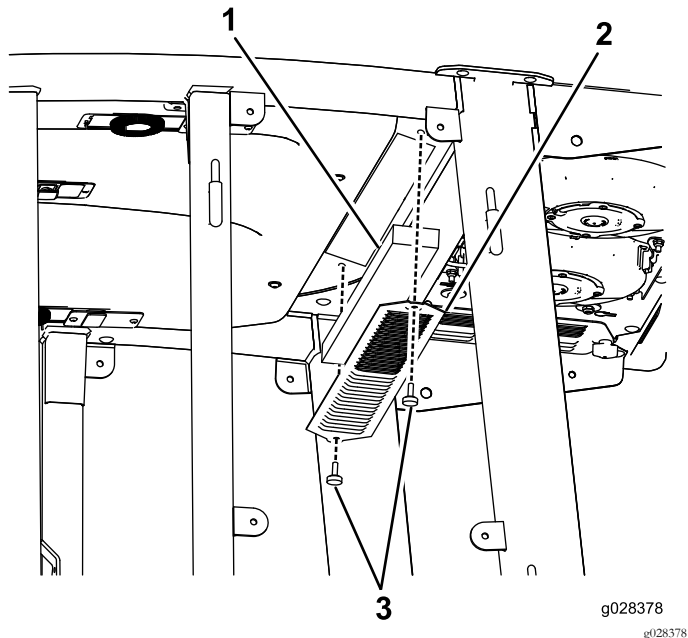

Figure 91
In-Cab Air Filter

1. Filter
2. Grate
3. Screw

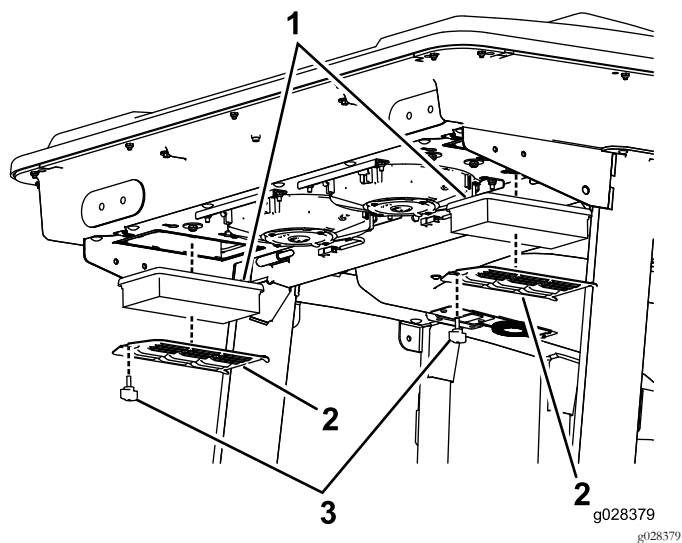

Figure 92
Rear Cab Air Filter

1. Filter
2. Grate
3. Screw

2. Clean the filters by blowing clean, oil-free, compressed air through them.

Important: If either filter has a hole, tear, or other damage, replace the filter.

3. Install the filters and the grate with the thumbscrews.

Cleaning the Cab Pre-Filter

The purpose of the cab pre-filter is to prevent large debris, such as grass and leaves from entering the cab filters.

1. Rotate the screen cover down.
2. Clean the filter with water.

Note: Do not use a pressure washer.

Important: If the filter has a hole, tear, or other damage, replace the filter.

3. Allow the pre-filter to dry before installing it into the machine.
4. Rotate the filter screen around the tabs until the latch locks into the latch-mount assembly (Figure 93).

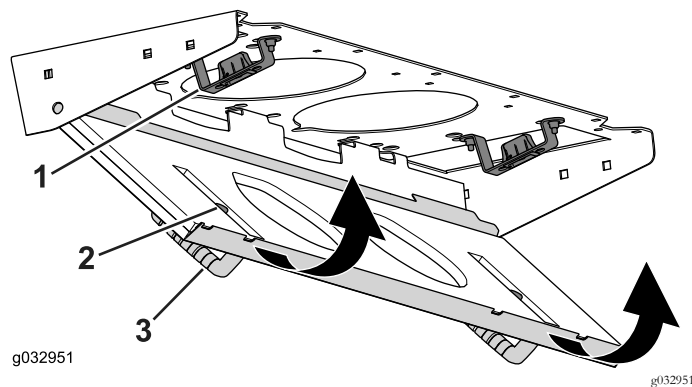

Figure 93

1. Latch-mount assembly
2. Latch
3. Screen cover

Cleaning the Air-Conditioning Assembly

Service Interval: Every 250 hours (more frequently in extremely dusty or dirty conditions).

1. Perform the pre-maintenance procedure; refer to [Preparing the Machine for Maintenance](#) (page 44).
2. Disconnect the wire for each fan.

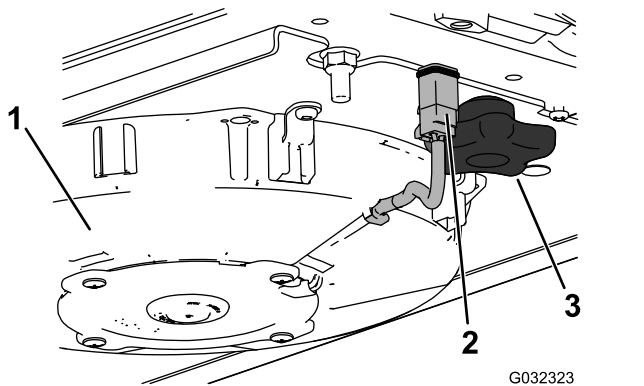

Figure 94
Right fan shown

- 1. Fan
- 2. Wire
- 3. Knob

- 3. Remove the 2 knobs and remove the fan assembly.
- 4. Open the 4 latches on the air-conditioning assembly and remove the screen.

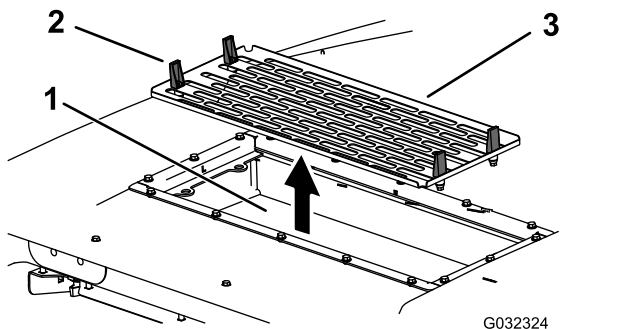

Figure 95

- 1. Air-conditioning coil
- 2. Latch
- 3. Air-conditioning screen

- 5. Remove the air filters (see [Figure 92](#)).
- 6. Clean the air-conditioning assembly.
- 7. Install the air filters, screen, and fan assembly ([Figure 92](#), [Figure 94](#), and [Figure 95](#)).
- 8. Connect the wire for each fan ([Figure 94](#)).

Cleaning

Important: Use care around cab seals and lights ([Figure 96](#)). If you are using a pressure washer, keep the washer wand at least 0.6 m (2 ft) away from the machine. Do not use pressure washer directly on cab seals and lights or under rear overhang.

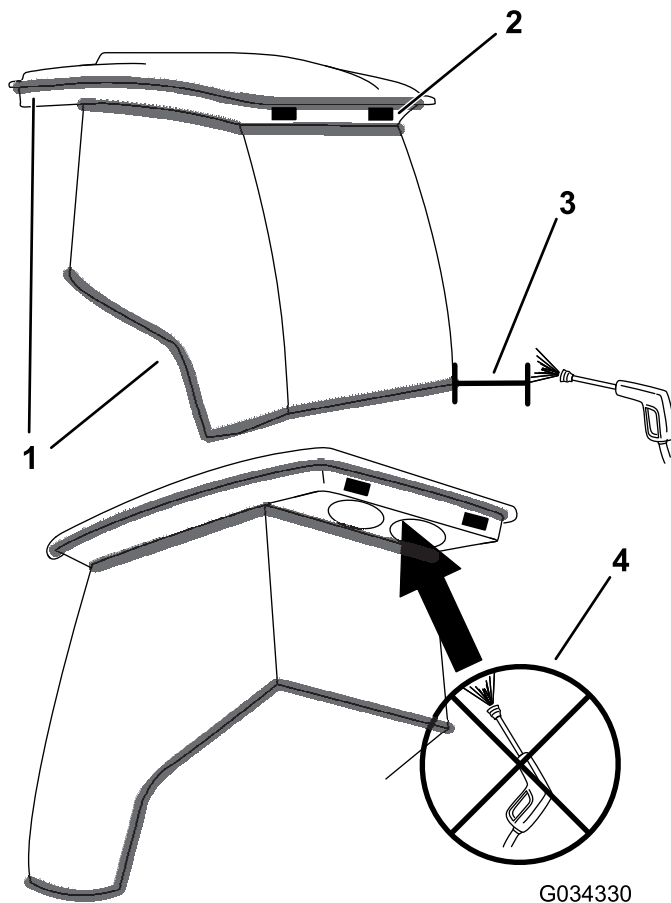

Figure 96

- 1. Seal
- 2. Light
- 3. Keep the wand 0.6 m (2 feet) away.
- 4. Do not pressure-wash under the rear overhang.

Storage

Preparing for Seasonal Storage

Traction Unit

1. Thoroughly clean the traction unit, mower decks, and the engine.
2. Check the tire pressure; refer to [Checking the Tire Pressure \(page 25\)](#).
3. Check all fasteners for looseness; tighten as necessary.
4. Grease or oil all grease fittings and pivot points. Wipe up any excess lubricant.
5. Lightly sand and use touch-up paint on painted areas that are scratched, chipped, or rusted. Repair any dents in the metal body.
6. Service the battery and cables as follows:
 - A. Remove the battery terminals from the battery posts.
 - B. Clean the battery, terminals, and posts with a wire brush and baking soda solution.
 - C. Coat the cable terminals and battery posts with Grafo 112X skin-over grease (Toro Part No. 505-47) or petroleum jelly to prevent corrosion.
 - D. Slowly recharge the battery every 60 days for 24 hours to prevent lead sulfation of the battery.

Engine

1. Drain the engine oil from the oil pan and install the drain plug.
2. Remove and discard the oil filter. Install a new oil filter.
3. Fill the oil pan with motor oil.
4. Start the engine and run it at idle speed for approximately 2 minutes.
5. Shut off the engine.
6. Flush the fuel tank with fresh, clean diesel fuel.
7. Secure all of the fuel system fittings.
8. Thoroughly clean and service the air-cleaner assembly.
9. Seal the air-cleaner inlet and the exhaust outlet with weatherproof tape.
10. Check the anti freeze protection and add a 50/50 solution of water and ethylene glycol anti-freeze as needed for the expected minimum temperature in your area.

Notes:

European Privacy Notice

The Information Toro Collects

Toro Warranty Company (Toro) respects your privacy. In order to process your warranty claim and contact you in the event of a product recall, we ask you to share certain personal information with us, either directly or through your local Toro company or dealer.

The Toro warranty system is hosted on servers located within the United States where privacy law may not provide the same protection as applies in your country.

BY SHARING YOUR PERSONAL INFORMATION WITH US, YOU ARE CONSENTING TO THE PROCESSING OF YOUR PERSONAL INFORMATION AS DESCRIBED IN THIS PRIVACY NOTICE.

The Way Toro Uses Information

Toro may use your personal information to process warranty claims, to contact you in the event of a product recall and for any other purpose which we tell you about. Toro may share your information with Toro's affiliates, dealers or other business partners in connection with any of these activities. We will not sell your personal information to any other company. We reserve the right to disclose personal information in order to comply with applicable laws and with requests by the appropriate authorities, to operate our systems properly or for our own protection or that of other users.

Retention of your Personal Information

We will keep your personal information as long as we need it for the purposes for which it was originally collected or for other legitimate purposes (such as regulatory compliance), or as required by applicable law.

Toro's Commitment to Security of Your Personal Information

We take reasonable precautions in order to protect the security of your personal information. We also take steps to maintain the accuracy and current status of personal information.

Access and Correction of your Personal Information

If you would like to review or correct your personal information, please contact us by email at legal@toro.com.

Australian Consumer Law

Australian customers will find details relating to the Australian Consumer Law either inside the box or at your local Toro Dealer.



The Toro Warranty

A Two-Year Limited Warranty

Conditions and Products Covered

The Toro Company and its affiliate, Toro Warranty Company, pursuant to an agreement between them, jointly warrant your Toro Commercial product ("Product") to be free from defects in materials or workmanship for two years or 1500 operational hours*, whichever occurs first. This warranty is applicable to all products with the exception of Aerators (refer to separate warranty statements for these products). Where a warrantable condition exists, we will repair the Product at no cost to you including diagnostics, labor, parts, and transportation. This warranty begins on the date the Product is delivered to the original retail purchaser.

* Product equipped with an hour meter.

Instructions for Obtaining Warranty Service

You are responsible for notifying the Commercial Products Distributor or Authorized Commercial Products Dealer from whom you purchased the Product as soon as you believe a warrantable condition exists. If you need help locating a Commercial Products Distributor or Authorized Dealer, or if you have questions regarding your warranty rights or responsibilities, you may contact us at:

Toro Commercial Products Service Department
Toro Warranty Company
8111 Lyndale Avenue South
Bloomington, MN 55420-1196
952-888-8801 or 800-952-2740
E-mail: commercial.warranty@toro.com

Owner Responsibilities

As the Product owner, you are responsible for required maintenance and adjustments stated in your *Operator's Manual*. Failure to perform required maintenance and adjustments can be grounds for disallowing a warranty claim.

Items and Conditions Not Covered

Not all product failures or malfunctions that occur during the warranty period are defects in materials or workmanship. This warranty does not cover the following:

- Product failures which result from the use of non-Toro replacement parts, or from installation and use of add-on, or modified non-Toro branded accessories and products. A separate warranty may be provided by the manufacturer of these items.
- Product failures which result from failure to perform recommended maintenance and/or adjustments. Failure to properly maintain your Toro product per the Recommended Maintenance listed in the *Operator's Manual* can result in claims for warranty being denied.
- Product failures which result from operating the Product in an abusive, negligent, or reckless manner.
- Parts subject to consumption through use unless found to be defective. Examples of parts which are consumed, or used up, during normal Product operation include, but are not limited to, brake pads and linings, clutch linings, blades, reels, rollers and bearings (sealed or greasable), bed knives, spark plugs, castor wheels and bearings, tires, filters, belts, and certain sprayer components such as diaphragms, nozzles, and check valves, etc.
- Failures caused by outside influence. Conditions considered to be outside influence include, but are not limited to, weather, storage practices, contamination, use of unapproved fuels, coolants, lubricants, additives, fertilizers, water, or chemicals, etc.
- Failure or performance issues due to the use of fuels (e.g. gasoline, diesel, or biodiesel) that do not conform to their respective industry standards.

Countries Other than the United States or Canada

Customers who have purchased Toro products exported from the United States or Canada should contact their Toro Distributor (Dealer) to obtain guarantee policies for your country, province, or state. If for any reason you are dissatisfied with your Distributor's service or have difficulty obtaining guarantee information, contact the Toro importer.

- Normal noise, vibration, wear and tear, and deterioration.
- Normal "wear and tear" includes, but is not limited to, damage to seats due to wear or abrasion, worn painted surfaces, scratched decals or windows, etc.

Parts

Parts scheduled for replacement as required maintenance are warranted for the period of time up to the scheduled replacement time for that part. Parts replaced under this warranty are covered for the duration of the original product warranty and become the property of Toro. Toro will make the final decision whether to repair any existing part or assembly or replace it. Toro may use remanufactured parts for warranty repairs.

Deep Cycle and Lithium-Ion Battery Warranty:

Deep cycle and Lithium-Ion batteries have a specified total number of kilowatt-hours they can deliver during their lifetime. Operating, recharging, and maintenance techniques can extend or reduce total battery life. As the batteries in this product are consumed, the amount of useful work between charging intervals will slowly decrease until the battery is completely worn out. Replacement of worn out batteries, due to normal consumption, is the responsibility of the product owner. Battery replacement may be required during the normal product warranty period at owner's expense. Note: (Lithium-Ion battery only): A Lithium-Ion battery has a part only prorated warranty beginning year 3 through year 5 based on the time in service and kilowatt hours used. Refer to the *Operator's Manual* for additional information.

Maintenance is at Owner's Expense

Engine tune-up, lubrication, cleaning and polishing, replacement of filters, coolant, and completing recommended maintenance are some of the normal services Toro products require that are at the owner's expense.

General Conditions

Repair by an Authorized Toro Distributor or Dealer is your sole remedy under this warranty.

Neither The Toro Company nor Toro Warranty Company is liable for indirect, incidental or consequential damages in connection with the use of the Toro Products covered by this warranty, including any cost or expense of providing substitute equipment or service during reasonable periods of malfunction or non-use pending completion of repairs under this warranty. Except for the Emissions warranty referenced below, if applicable, there is no other express warranty. All implied warranties of merchantability and fitness for use are limited to the duration of this express warranty.

Some states do not allow exclusions of incidental or consequential damages, or limitations on how long an implied warranty lasts, so the above exclusions and limitations may not apply to you. This warranty gives you specific legal rights, and you may also have other rights which vary from state to state.

Note regarding engine warranty:

The Emissions Control System on your Product may be covered by a separate warranty meeting requirements established by the U.S. Environmental Protection Agency (EPA) and/or the California Air Resources Board (CARB). The hour limitations set forth above do not apply to the Emissions Control System Warranty. Refer to the Engine Emission Control Warranty Statement supplied with your product or contained in the engine manufacturer's documentation for details